

**NISSAN
TRUCK/
PATHFINDER**
MODEL D21 SERIES

QUICK REFERENCE INDEX

GENERAL INFORMATION _____	GI
MAINTENANCE _____	MA
ENGINE MECHANICAL _____	EM
ENGINE LUBRICATION & COOLING SYSTEMS —	LC
ENGINE FUEL & EMISSION CONTROL SYSTEM —	EF & EC
ENGINE CONTROL, FUEL & EXHAUST SYSTEMS -	FE
CLUTCH _____	CL
MANUAL TRANSMISSION _____	MT
AUTOMATIC TRANSMISSION _____	AT
TRANSFER _____	TF
PROPELLER SHAFT & DIFFERENTIAL CARRIER —	PD
FRONT AXLE & FRONT SUSPENSION _____	FA
REAR AXLE & REAR SUSPENSION _____	RA
BRAKE SYSTEM _____	BR
STEERING SYSTEM _____	ST
BODY _____	BF
HEATER & AIR CONDITIONER _____	HA
ELECTRICAL SYSTEM _____	EL

FOREWORD

This manual contains maintenance and repair procedures for the 1989 Nissan TRUCK and PATHFINDER.

In order to assure your safety and the efficient functioning of the vehicle, this manual should be read thoroughly. It is especially important that the PRECAUTIONS in the GI section be completely understood before starting any repair task.

All information in this manual is based on the latest product information at the time of publication. The right is reserved to make changes in specifications and methods at any time without notice.

IMPORTANT SAFETY NOTICE

The proper performance of service is essential for both the safety of the technician and the efficient functioning of the vehicle.

The service methods in this Service Manual are described in such a manner that the service may be performed safely and accurately.

Service varies with the procedures used, the skills of the technician and the tools and parts available. Accordingly, anyone using service procedures, tools or parts which are not specifically recommended by NISSAN must first completely satisfy himself that neither his safety nor the vehicle's safety will be jeopardized by the service method selected.



NISSAN MOTOR CO., LTD.

Overseas Service Department

Tokyo, Japan

GENERAL INFORMATION



SECTION **GI**

CONTENTS

PRECAUTIONS	GI- 2
HOW TO USE THIS MANUAL	GI- 5
HOW TO READ WIRING DIAGRAMS	GI- 7
IDENTIFICATION INFORMATION	GI-11
RECOMMENDED FUEL AND LUBRICANTS	GI-18
LIFTING POINTS AND TOW TRUCK TOWING	GI-20
TIGHTENING TORQUE OF STANDARD BOLTS	GI-24

PRECAUTIONS

The following precautions should be observed to ensure safe and proper service operations. These precautions are not described in each individual section.

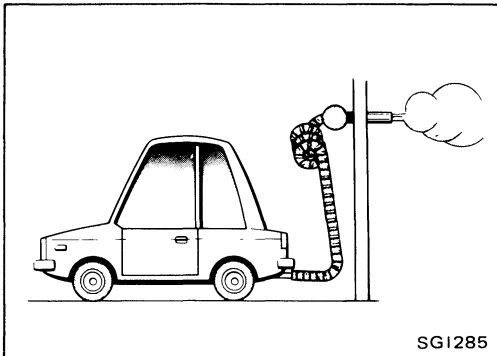

1. Do not operate the engine for an extended period of time without proper exhaust ventilation. Keep the work area well ventilated and free of any inflammable materials. Special care should be taken when handling any inflammable or poisonous materials, such as gasoline, refrigerant gas, etc. When working in a pit or other enclosed area, be sure to properly ventilate the area before working with hazardous materials.

Do not smoke while working on the vehicle.

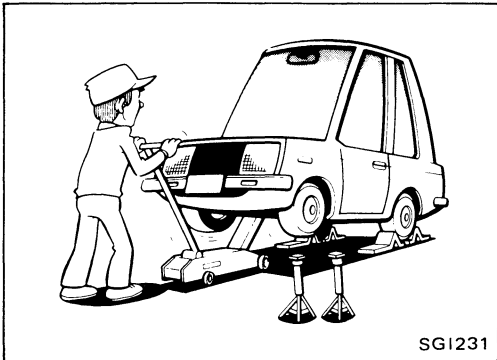

2. Before jacking up the vehicle, apply wheel chocks or other tire blocks to the wheels to prevent the vehicle from moving. After jacking up the vehicle, support the vehicle weight with safety stands at the points designated for proper lifting and towing before working on the vehicle.

These operations should be done on a level surface.

3. When removing a heavy component such as the engine or transaxle/transmission, take care not to lose your balance and drop it. Also, do not allow it to hit against adjacent parts, especially brake tube and brake master cylinder.

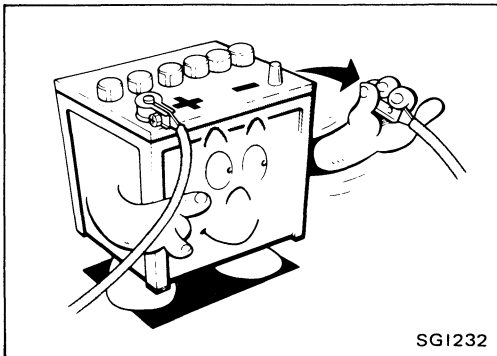

4. Before starting repairs which do not require battery power, always turn off the ignition switch, then disconnect the ground cable from the battery to prevent accidental short circuit.



5. To prevent serious burns, avoid contact with hot metal parts such as the radiator, exhaust manifold, tail pipe and muffler. Do not remove the radiator cap when the engine is hot.

PRECAUTIONS

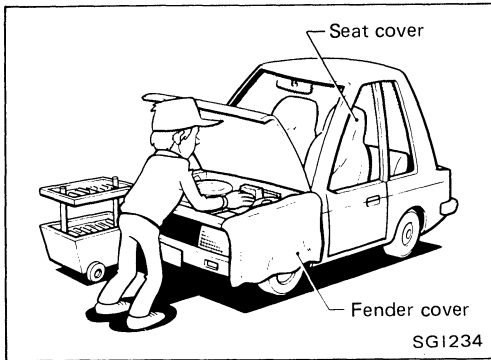

6. To prevent scratches and soiling, protect fenders, upholstery and carpeting with appropriate covers before starting servicing.
Take caution that keys, buckles or buttons on your person do not scratch the paint.
7. Clean all disassembled parts in the designated liquid or solvent prior to inspection or assembly.
8. Replace oil seals, gaskets, packings, O-rings, locking washers, cotter pins, self-locking nuts, etc. as instructed and discard used ones.
9. Tapered roller bearings and needle bearings should be replaced as a set of inner and outer races.
10. Arrange the disassembled parts in accordance with their assembled locations and sequence.
11. Do not touch the terminals of electrical components which utilize microcomputers such as electronic control units. Static electrical charges stored in your body may damage internal electronic components.
12. After disconnecting vacuum hose or air hose, attach tag which indicates the proper connection to prevent incorrect connection.
13. Use only the lubricants specified in the applicable section or those indicated under "Recommended Fuel and Lubricants".
14. Use approved bonding agent, sealants or their equivalents when required.
15. The use of the proper tools and recommended essential tools should be used where specified for proper, safe and efficient service repairs.
16. When effecting repairs on the fuel, oil, water, vacuum or exhaust systems, make certain to check all affected lines for leaks.
17. Dispose of drained oil or the solvent used for cleaning parts in an appropriate manner.

PRECAUTIONS

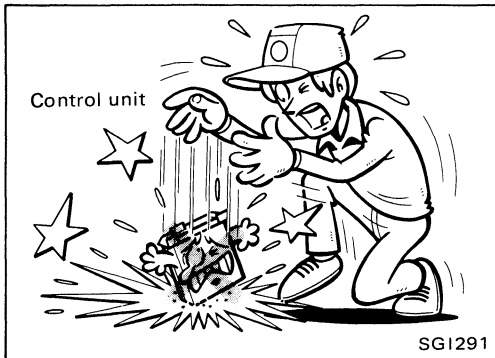

Precautions for E.F.I. or E.C.C.S. Engine

1. Before connecting or disconnecting E.F.I. or E.C.C.S. harness connector to or from any E.F.I. or E.C.C.S. control unit, be sure to turn the ignition switch to the "OFF" position and disconnect the negative battery terminal.
Otherwise, there may be damage to control unit.
2. Before disconnecting pressurized fuel line from fuel pump to injectors, be sure to release fuel pressure to eliminate danger.
3. Be careful not to jar components such as control unit and air flow meter.

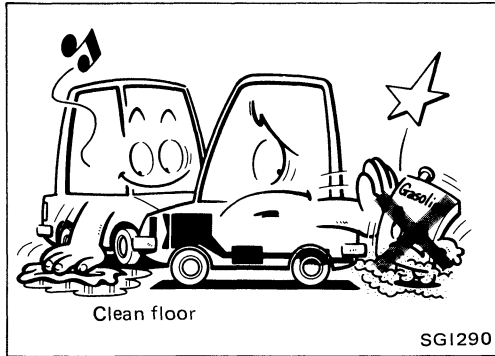

Precautions for a Catalyst

If a large amount of unburned fuel flows into the converter, the converter temperature will be excessively high. To prevent this, follow the procedure below.

1. Use unleaded gasoline only. Leaded gasoline will seriously damage the catalytic converter.
2. When checking for ignition spark or measuring engine compression, make tests quickly and only when necessary.
3. Do not run engine when the fuel tank level is low, otherwise the engine may misfire causing damage to the converter.
4. Do not place the vehicle on inflammable material. Keep inflammable material off the exhaust pipe.

HOW TO USE THIS MANUAL

1. **A QUICK REFERENCE INDEX**, a black tab (e.g. **FA**) is provided on the first page. You can quickly find the first page of each section by mating it to the section's black tab.
2. **THE CONTENTS** are listed on the first page of each section.
3. **THE TITLE** is indicated on the upper portion of each page and shows the part or system.
4. **THE PAGE NUMBER** of each section consists of two letters, which designate the particular section, and a number (e.g. "FA-5").
5. **THE LARGE ILLUSTRATION** is an exploded view (See below) and contains tightening torques, lubrication points and other information necessary to perform repairs. The illustration should be used in reference to the service matters only. When ordering parts, refer to the appropriate **PARTS CATALOG**.

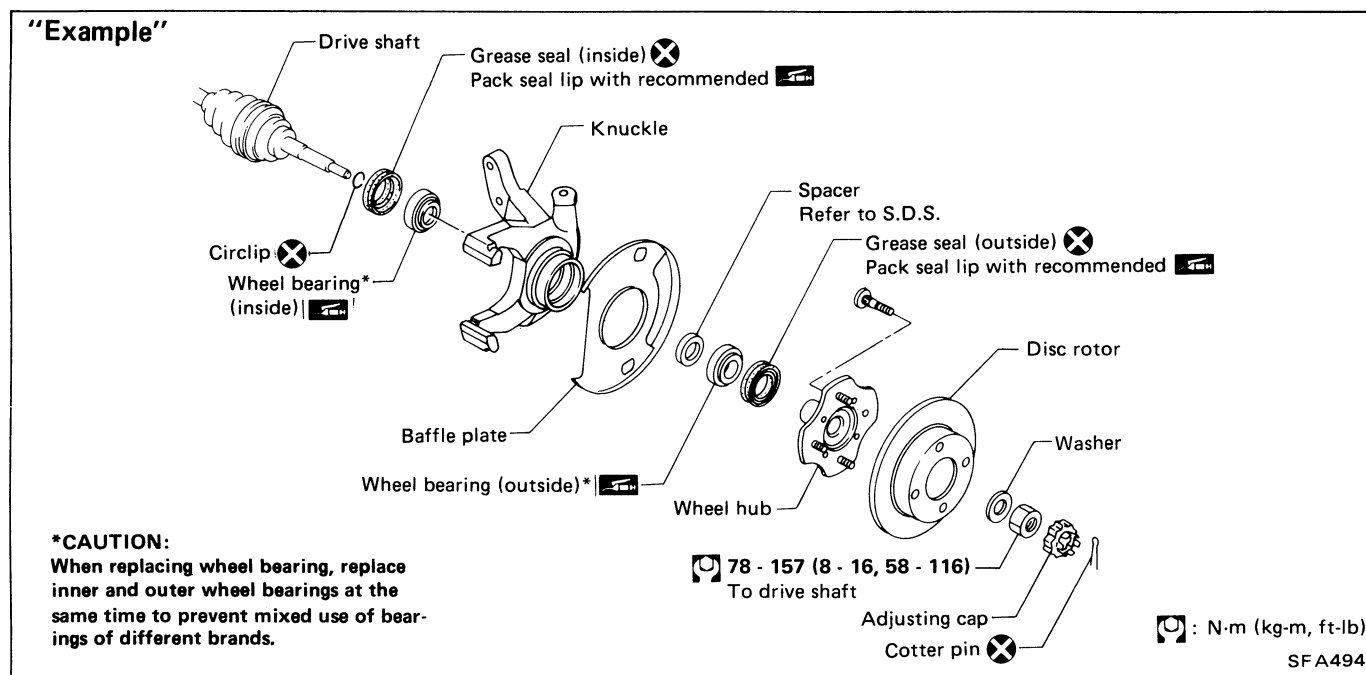

6. **THE SMALL ILLUSTRATION** shows the important steps such as inspection, use of special tools, knacks of work and hidden or tricky steps which are not shown in the previous large illustration. Assembly, inspection and adjustment procedures for the complicated units such as the automatic transaxle or transmission, etc. are presented in a step-by-step format where necessary.
7. The followings **SYMBOLS AND ABBREVIATIONS** are used:



: Tightening Torque



: Should be lubricated with grease.
Unless otherwise indicated, use recommended multi-purpose grease.



: Should be lubricated with oil.



: Sealing point



: Checking point



: Always replace when disassembled.

S.D.S.: Service Data and Specifications

L.H., R.H.: Left-Hand, Right-Hand

M/T: Manual Transaxle/Transmission

A/T: Automatic Transaxle/Transmission

Tool: Special Service Tools

HOW TO USE THIS MANUAL

8. The **UNITS** given in this manual are primarily expressed with the SI UNIT (International System of Unit), and alternately expressed in the metric system and in the yard/pound system.

“Example”

Tightening torque

59 - 78 N·m (6.0 - 8.0 kg-m, 43 - 58 ft-lb)

9. **TROUBLE DIAGNOSES AND CORRECTIONS** are included in sections dealing with complicated components.
10. **SERVICE DATA AND SPECIFICATIONS** is contained at the end of each section for quick reference of data.
11. The captions **WARNING** and **CAUTION** warn you of steps that must be followed to prevent personal injury and/or damage to some part of the vehicle.

HOW TO READ WIRING DIAGRAMS

WIRING DIAGRAM

Symbols used in WIRING DIAGRAM are shown below.

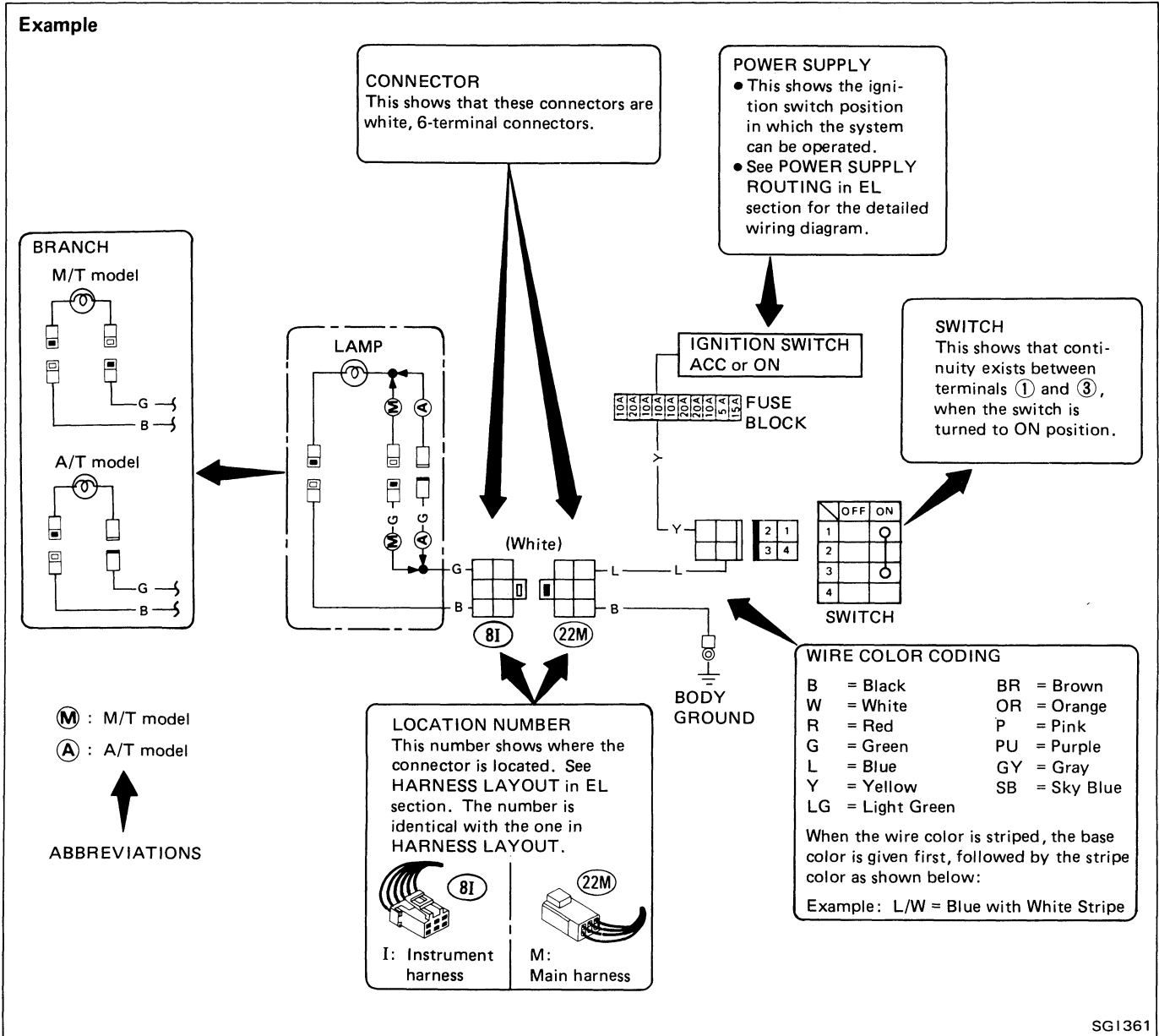

SGI361

HOW TO READ WIRING DIAGRAMS

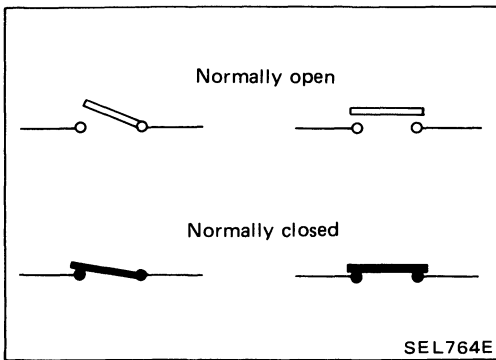

SWITCH POSITIONS

Wiring diagram switches are shown with the vehicle in the following condition:

- Ignition switch "OFF".
- Doors, hood and trunk lid/back door closed.
- Pedals are not depressed and parking brake is released.

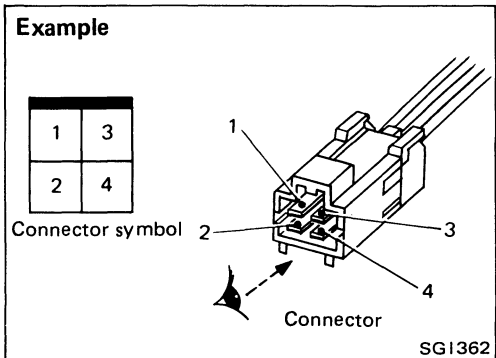

CONNECTOR SYMBOLS

- All connector symbols in wiring diagrams are shown from the terminal side.

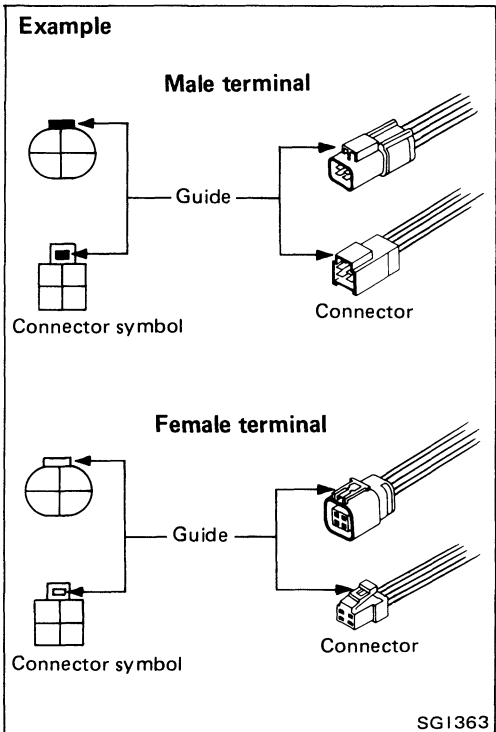

- Male and female terminals
Connector guides for male terminals are shown in black and female terminals in white in wiring diagrams.

HOW TO READ WIRING DIAGRAMS

Example

View from terminal side

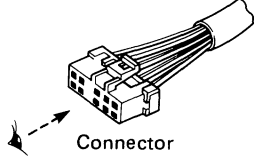

Connector

Connector symbol

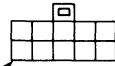

Single line

Direction mark

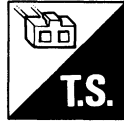

View from harness side

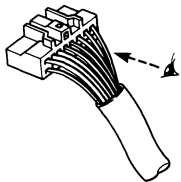

Connector

Connector symbol



Double lines

Direction mark



SGI364

DIRECTION MARK

A direction mark is shown to clarify the side of connector (terminal side or harness side).

Direction marks are mainly used in the illustrations indicating terminal inspection.



: View from terminal side . . . T.S.

- All connector symbols shown from the terminal side are enclosed by a single line.



: View from harness side . . . H.S.

- All connector symbols shown from the harness side are enclosed by double lines.

MULTIPLE SWITCH

The continuity of the multiple switch is identified in the switch chart in wiring diagrams.

Example

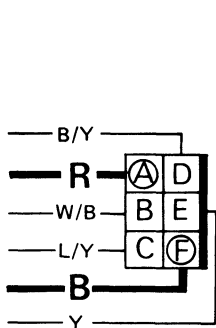

WIPER SWITCH

	OFF	INT	LO	HI	WASH
1					○
2				○	○
③	○	○	●	○	○
4	○	○	○	○	○
5		○	○	○	○
⑥	○	○	○	○	○

Continuity circuit of wiper switch

SWITCH POSITION	CONTINUITY CIRCUIT
OFF	3 - 4
INT	3 - 4, 5 - 6
LO	3 - 6
HI	2 - 6
WASH	1 - 6

Example: Wiper switch in LO position

Continuity circuit: Red wire - (A) terminal - (③) terminal - Wiper switch (● - ●): LO) - (⑥) terminal - (F) terminal - Black wire

SGI365

HOW TO READ WIRING DIAGRAMS

SUPER MULTIPLE JUNCTION (S.M.J.)

- The "S.M.J." indicated in wiring diagrams is shown in a simplified form. The terminal arrangement should therefore be referred to in the foldout at the end of the Service Manual.
- The foldout should be spread to read the entire wiring diagram.

"Example"

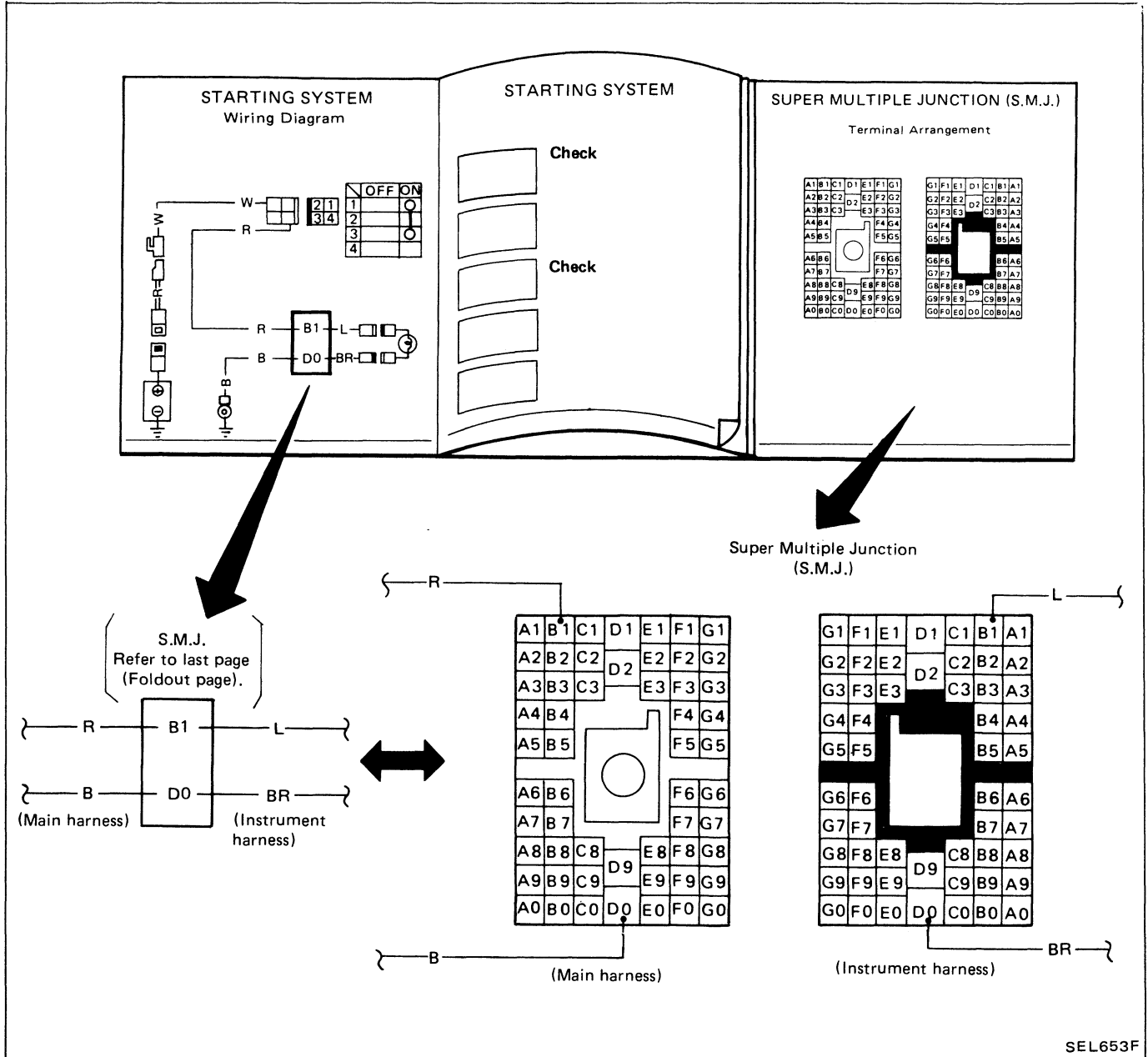

SEL653F

2-WHEEL DRIVE TRUCK

Destination	Engine		Z24i				VG30i			
	Transmission		F4W71C	FS5W71C	L4N71B (Floor shift)	L4N71B (Column shift)	FS5R30A	E4N71B (Floor shift)	E4N71B (Column shift)	
	Body		Differential carrier		H190A	H190A	H190A	H190A	H233B	H233B
Non-California, U.S.A.	Regular Cab	STD	Standard wheelbase	NLD21SEU	-	-	NLD21SYEU	-	-	-
		E		-	NLD21FEU	-	NLD21YEU	-	-	-
	King Cab	E	Long wheelbase	-	KNLGD21FEU	KNLGD21KEU	-	-	-	-
		SE		-	-	-	KHLGD21PFEU	KHLGD21PKEU	-	-
Heavy duty	E		-	-	-	-	EHLGD21FEU	-	EHLGD21YEU	
California, U.S.A.	Regular Cab	STD	Standard wheelbase	NLD21SEV	-	-	NLD21SYEV	-	-	-
		E		-	NLD21FEV	-	NLD21YEV	-	-	-
	King Cab	E	Long wheelbase	-	KNLGD21FEV	KNLGD21KEV	-	-	-	-
		SE		-	-	-	KHLGD21PFEV	KHLGD21PKEV	-	-
Heavy duty	E		-	-	-	-	EHLGD21FEV	-	EHLGD21YEV	
Canada	Regular Cab	STD	Standard wheelbase	NLD21SEN	-	-	-	-	-	-
		E		-	-	-	NLD21YEN	-	-	-
	King Cab	E	Long wheelbase	-	NLGD21FEN	-	NLGD21YEN	-	-	-
		SE		-	KNLGD21FEN	KNLGD21KEN	-	-	-	-
		E	Long wheelbase	-	-	-	-	KHLGD21PFEN	KHLGD21PKEN	-
SE	-	-		-	-	EHLGD21FEN	-	EHLGD21YEN		

GI-11

Model Variation

IDENTIFICATION INFORMATION

IDENTIFICATION INFORMATION

Model Variation (Cont'd)

4-WHEEL DRIVE TRUCK

Destination	Engine		Z24i		VG30i					
	Transmission		FS5W71C		FS5R30A		RE4R01A			
	Transfer		TX10		TX10		TX10			
	Differential carrier		Front R180A	Rear C200	Front R200A	Rear H233B	Front R200A	Rear H233B		
Non-California, U.S.A.	Regular Cab	E	Standard wheelbase		NLYD21FEU		HLYD21FEU		HLYD21KEU	
	King Cab	E	Long wheelbase		KNLMD21FEU		-		-	
		SE			-		KHLMD21PFEU		KHLMD21PKEU	
California, U.S.A.	Regular Cab	E	Standard wheelbase		NLYD21FEV		HLYD21FEV		HLYD21KEV	
	King Cab	E	Long wheelbase		KNLMD21FEV		-		-	
		SE			-		KHLMD21PFEV		KHLMD21PKEV	
Canada	Regular Cab	E	Standard wheelbase		NLYD21FEN		-		-	
		XE			NLYD21JFEN		-		-	
	King Cab	XE	Long wheelbase		KNLMD21JFEN		-		-	
		SE			-		KHLMD21PFEN		KHLMD21PKEN	

4-WHEEL DRIVE PATHFINDER

Destination	Engine		Z24i		VG30i			
	Transmission		FS5W71C		FS5R30A		RE4R01A	
	Transfer		TX10		TX10		TX10	
	Differential carrier		Front R180A	Rear C200	Front R200A	Rear H233B	Front R200A	Rear H233B
Non-California, U.S.A.	Wagon	E	WNLYD21FEU		-		-	
		XE	-		WHLYD21JFEU		WHLYD21JKEU	
		SE	-		WHLYD21PFEU		WHLYD21PKEU	
California, U.S.A.	Wagon	XE	-		WHLYD21JFEV		WHLYD21JKEV	
		SE	-		WHLYD21PFEV		WHLYD21PKEV	
Canada	Van	E	VNLYD21FEN		-		-	
		XE	-		VHLYD21JFEN		VHLYD21JKEN	
		SE	-		VHLYD21PFEN		VHLYD21PKEN	

IDENTIFICATION INFORMATION

Model Variation (Cont'd)

Prefix and suffix designations:

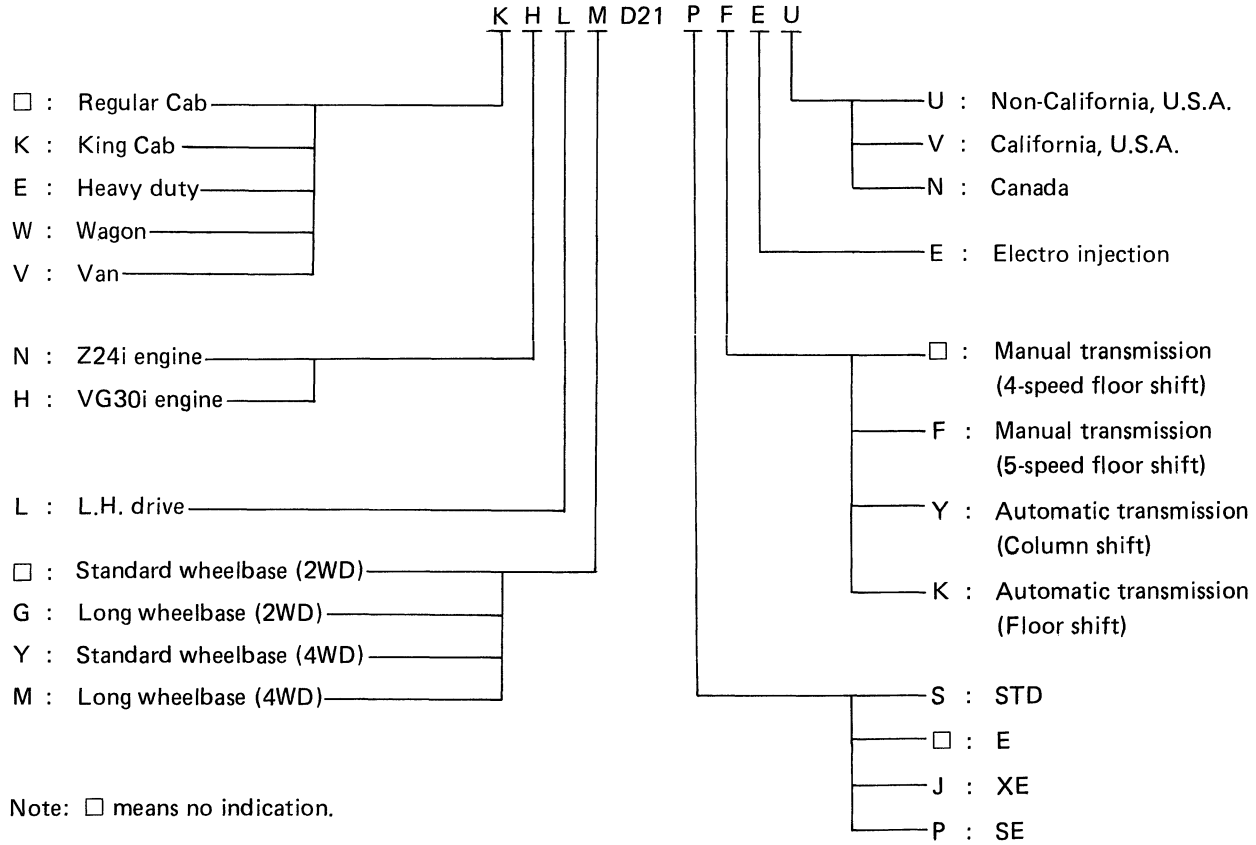

Note: □ means no indication.

Identification Number

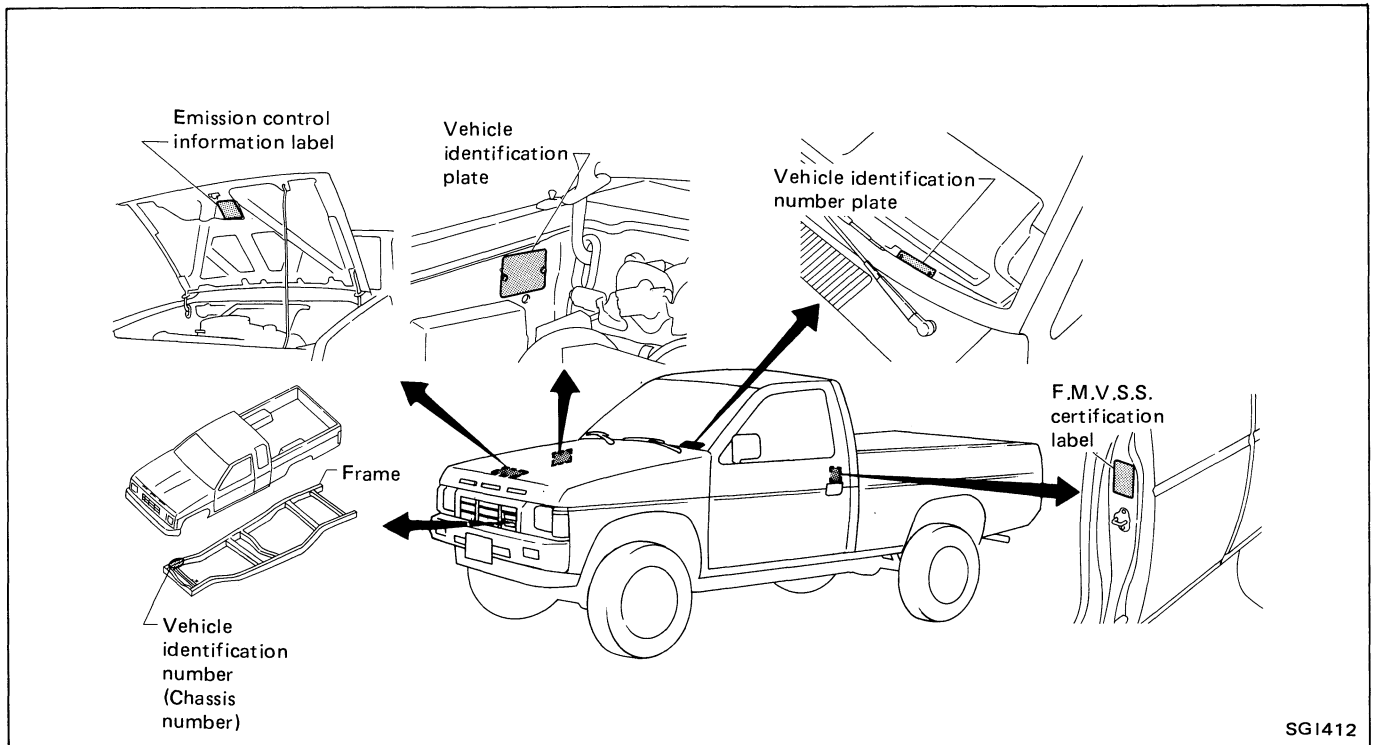

SGI412

IDENTIFICATION INFORMATION

Identification Number (Cont'd)

VEHICLE IDENTIFICATION NUMBER ARRANGEMENT

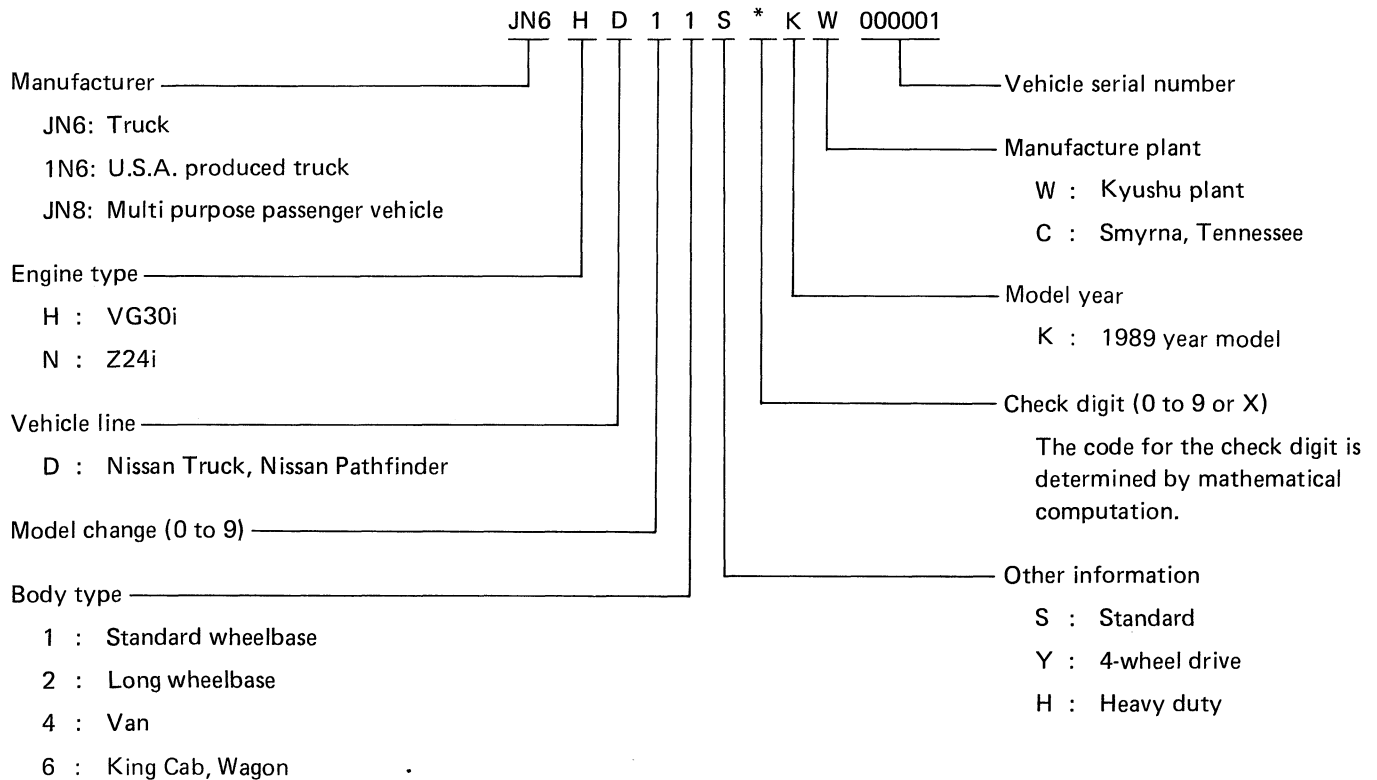

The 1989 models start production with the following vehicle identification numbers (chassis number) with the exception of those produced in U.S.A. produced trucks.

- JN6HD11S*KW100001
- JN6HD12S*KW100001
- JN6HD16S*KW100001
- JN6ND11S*KW100001
- JN6ND12S*KW100001
- JN6ND16S*KW100001
- JN6HD12H*KW100001
- JN6HD15H*KW100001
- JN6HD11Y*KW100001
- JN6HD16Y*KW100001
- JN6ND11Y*KW100001
- JN6ND12Y*KW100001
- JN6ND16Y*KW100001
- JN8ND16Y*KW100001
- JN8HD16Y*KW100001
- JN8HD14Y*KW100001
- JN6ND14Y*KW100001

IDENTIFICATION INFORMATION

Identification Number (Cont'd)



IDENTIFICATION PLATE



NISSAN MOTOR CO., LTD. JAPAN



型式 TYPE
TIPO TIPO 

CHASSIS NO. NO. DE CHASIS 

MODEL MODELO 

○ カラー COLOR TRIM トリム COLOR GUARNICION   ○

エン ENGINE ジン MOTOR   CC

ミッション TRANS., AXLE アクスル TRANS., EJE  

工場 PLANT PLANTA

日産自動車株式会社 MADE IN JAPAN

- 1 Type
- 2 Vehicle identification number (Chassis number)
- 3 Model
- 4 Body color code
- 5 Trim color code
- 6 Engine model
- 7 Engine displacement
- 8 Transmission model
- 9 Axle model

SGI315

ENGINE SERIAL NUMBER

VG30i engine

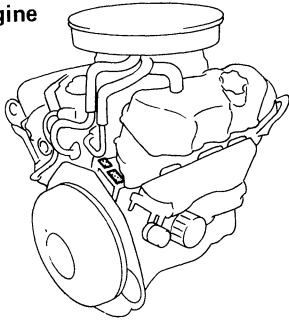

Z24i engine

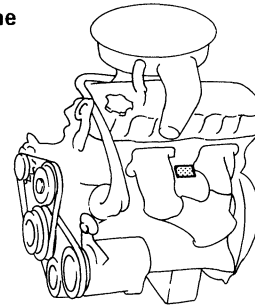

SGI505

TRANSMISSION SERIAL NUMBER

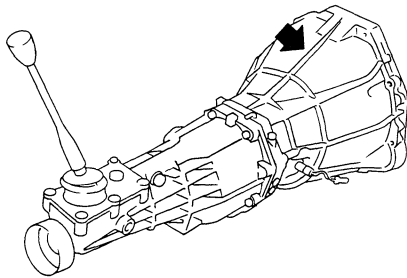

Manual transmission number

SGI418

L4N71B, E4N71B

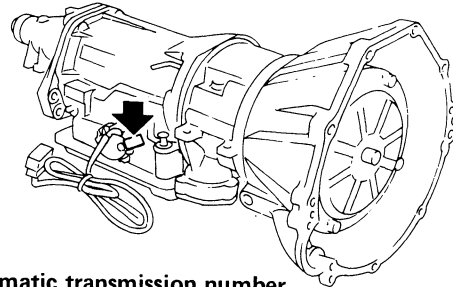

Automatic transmission number

SGI273

TRANSMISSION SERIAL NUMBER RE4R01A

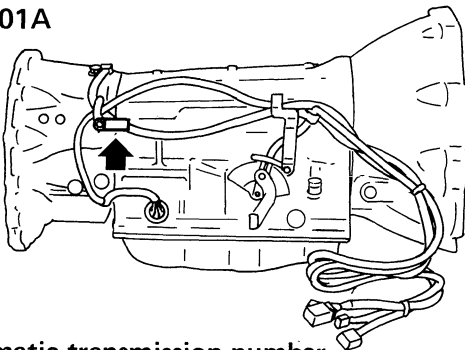

Automatic transmission number

SGI509

TRANSFER SERIAL NUMBER

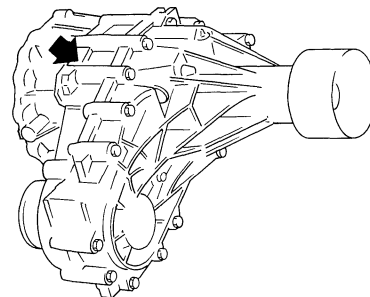

SGI419

IDENTIFICATION INFORMATION

Dimensions

Truck

Unit: mm (in)

		2-wheel drive				4-wheel drive	
		Regular Cab		King Cab Heavy duty		Regular Cab	King Cab
		Standard wheelbase	Long wheelbase			Standard wheelbase	Long wheelbase
Overall length	4,435 (174.6)	4,825 (190.0)	4,825 (190.0)	4,825 (190.0)	4,435 (174.6)	4,825 (190.0)	
Overall width	1,650 (65.0)	1,650 (65.0)	1,650 (65.0)	1,650 (65.0)	1,690 (66.5)	1,690 (66.5)	
Overall height	1,575 (62.0)	1,575 (62.0)	1,575 (62.0)	1,575 (62.0)	1,695 (66.7)	1,695 (66.7)	
Front tread	1,395 (54.9)	1,395 (54.9)	1,395 (54.9)	1,395 (54.9)	1,425 (56.1)	1,425 (56.1)	
Rear tread (Z24i engine model)	1,385 (54.5)	1,385 (54.5)	1,385 (54.5)	—	1,385 (54.5)	1,385 (54.5)	
Rear tread (VG30i engine model)	1,410 (55.5)	1,410 (55.5)	1,410 (55.5)	1,410 (55.5)	1,410 (55.5)	1,410 (55.5)	
Wheelbase	2,650 (104.3)	2,950 (116.1)	2,950 (116.1)	2,950 (116.1)	2,650 (104.3)	2,950 (116.1)	
Cargo space	Length	1,875 (73.8)	2,265 (89.2)	1,895 (74.6)	2,265 (89.2)	1,875 (73.8)	1,895 (74.6)
	Width	1,520 (59.8)	1,520 (59.8)	1,520 (59.8)	1,520 (59.8)	1,520 (59.8)	1,520 (59.8)
	Height	435 (17.1)	435 (17.1)	435 (17.1)	435 (17.1)	435 (17.1)	435 (17.1)

Pathfinder

Unit: mm (in)

		Wagon		Van
		VG30i	Z24i	Z24i
Overall length	4,365 (171.9)	4,365 (171.9)	4,365 (171.9)	
Overall width	1,690 (66.5)	1,690 (66.5)	1,690 (66.5)	
Overall height	1,670 (65.7)/1,680 (66.1)*	1,670 (65.7)	1,670 (65.7)	
Front tread	1,425 (56.1)/1,445 (56.9)*	1,425 (56.1)	1,425 (56.1)	
Rear tread	1,410 (55.5)/1,430 (56.3)*	1,385 (54.5)	1,385 (54.5)	
Wheelbase	2,650 (104.3)	2,650 (104.3)	2,650 (104.3)	

*: SE model

IDENTIFICATION INFORMATION

Wheels & Tires

Body	Grade	Road wheel/offset mm (in)	Tire
4x2 Regular and King Cab	STD	5-Jx14/40 (1.57)	P185/75R14
	E	5-Jx14/40 (1.57)	P195/75R14
	XE	5-Jx14/40 (1.57)	P195/75R14
	SE	6-JJx14/30 (1.18) 6-JJx14 Aluminum/30 (1.18)*	P215/75R14
	Heavy duty	E	5-Jx14/40 (1.57)
4x4 Regular, King Cab and Pathfinder	E	5-1/2-Kx15/40 (1.57)	P215/75R15
	XE	5-1/2-Kx15/40 (1.57)	P215/75R15
	SE	6-JJx15/30 (1.18) 7-JJx15 Aluminum/25 (0.98)*	P235/75R15 31x10.5R15*

*: Option

RECOMMENDED FUEL AND LUBRICANTS

Fuel and Lubricants

			Capacity (Approximate)			Recommended Fuel/Lubricants	
			US measure	Imp measure	Liter		
Fuel			15-7/8 gal 21-1/8 gal*1	13-1/4 gal 17-5/8 gal*1	60 80*1	Unleaded gasoline with an octane rating of at least 87 AKI (RON 91)	
Engine oil (Refill)							
VG30i	2WD	With oil filter	4-1/4 qt	3-1/2 qt	4.0	Genuine Nissan Motor Oil*4 or equivalent Energy Conserving Oils*3 of API SF or SG	
		Without oil filter	3-7/8 qt	3-1/8 qt	3.6		
VG30i	4WD	With oil filter	3-5/8 qt	3 qt	3.4		
		Without oil filter	3-1/8 qt	2-5/8 qt	3.0		
Z24i	2WD	With oil filter	4 qt	3-3/8 qt	3.8		
		Without oil filter	3-1/2 qt	2-7/8 qt	3.3		
Z24i	4WD	With oil filter	4-1/2 qt	3-3/4 qt	4.3		
		Without oil filter	4 qt	3-3/8 qt	3.8		
Cooling system (With heater)							
VG30i			10-1/2 qt	8-3/4 qt	9.9		Anti-freeze coolant (Ethylene glycol base)
Z24i			8-5/8 qt	7-1/4 qt	8.2		
Reservoir tank			5/8 qt	1/2 qt	0.6		
Manual transmission gear oil							
		F4W71C	3-5/8 pt	3 pt	1.7	API GL-4*2	
		FS5W71C	2WD	4-1/4 pt	3-1/2 pt		2.0
			4WD	8-1/2 pt	7 pt		4.0
		FS5R30A	2WD	5-1/8 pt	4-1/4 pt		2.4
4WD	7-5/8 pt		6-3/8 pt	3.6			
Transfer gear oil							
			2-3/8 qt	2 qt	2.2		
Manual steering gear oil							
			3/4 pt	5/8 pt	0.33		
Differential carrier gear oil							
Rear:		H190A	3-1/8 pt	2-5/8 pt	1.5	Standard differential gear: API GL-5*2 Limited-slip differential (L.S.D.) gear: Use only LSD gear oil API GL-5 and SAE 80W-90*5 approved for Nissan LSD*6.	
		C200	2-3/4 pt	2-1/4 pt	1.3		
		H233B	5-7/8 pt	4-7/8 pt	2.8		
Front (4WD):		R180A	2-3/4 pt	2-1/4 pt	1.3		
		R200A	3-1/8 pt	2-5/8 pt	1.5		
Automatic transmission fluid							
		L4N71B, E4N71B	7-3/8 qt	6-1/8 qt	7.0	Genuine Nissan ATF*4 or equivalent Type DEXRON™	
		RE4R01A	9 qt	7-1/2 qt	8.5		
Power steering fluid							
			2-1/8 pt	1-3/4 pt	1.0	Type DEXRON™	
Brake and clutch fluid							
			—	—	—	Genuine Nissan Brake Fluid*4 or equivalent DOT 3 (US FMVSS No. 116)	
Multi-purpose grease							
			—	—	—	NLGI No. 2 (Lithium soap base)	
Free-running hub grease (Auto-lock)							
			—	—	—	Genuine Nissan grease or equivalent	

*1: VG30i engine models except 2WD Truck SE models and 4WD Truck E models.

*2: For further details, see the recommended SAE viscosity number chart.

*3: These oils can be identified by such labels as energy conserving, energy saving, improved fuel economy, etc.

*4: Available in mainland U.S.A. through your Nissan dealer.

*5: SAE 90 is acceptable in ambient temperatures above -18°C (0°F).

*6: Contact a Nissan dealer for a list of approved oils.

RECOMMENDED FUEL AND LUBRICANTS

SAE Viscosity Number

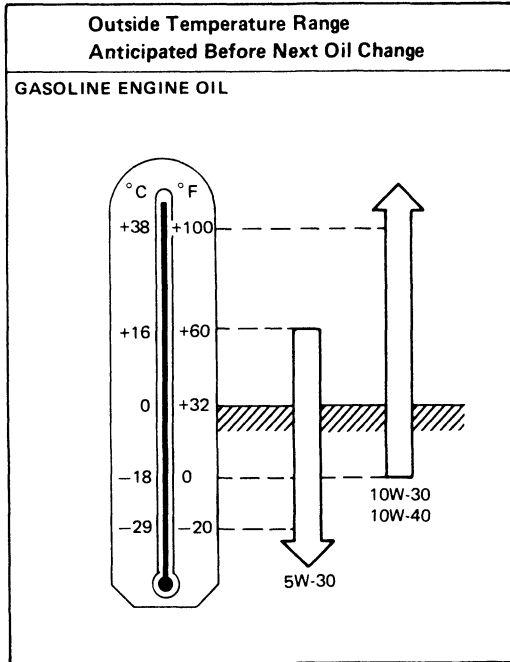

T10002

10W-30 is preferable if the ambient temperature is above -18°C (0°F). 20W-40 and 20W-50 are usable if the ambient temperature is above 10°C (50°F) for all seasons.

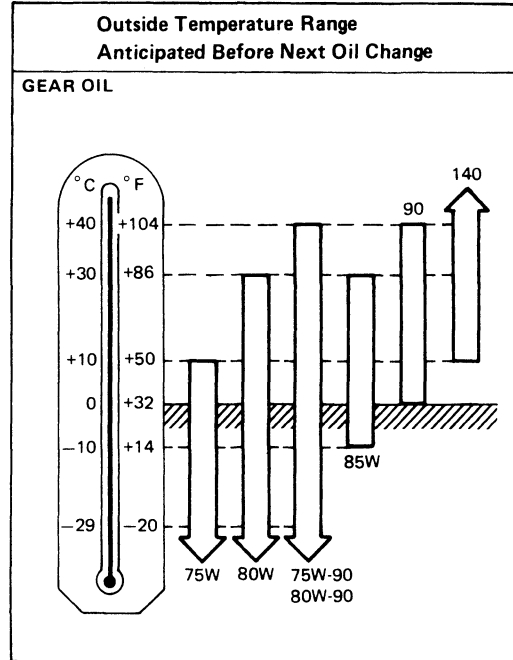

T10003

75W-90 for transmission and transfer, and 80W-90 for differential are preferable if the ambient temperature is below 40°C (104°F).

LIFTING POINTS AND TOW TRUCK TOWING

WARNING:

- Never get under the vehicle while it is supported only by the jack. Always use safety stands to support the frame when you have to get under the vehicle.
- Place wheel chocks at both front and back of the wheel which is diagonally opposite the jack position.
Example: If the jack is positioned at the L.H. front wheel, place wheel chocks at R.H. rear wheel.

Screw Jack

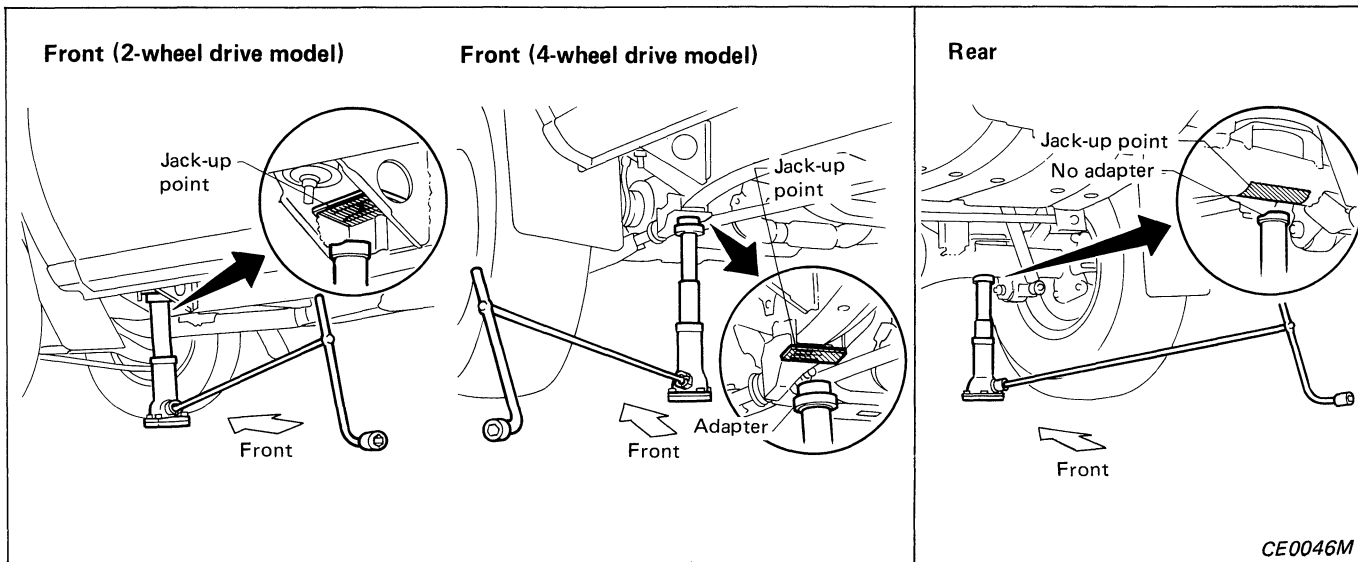

Garage Jack and Safety Stand

CAUTION:

- Place a wooden or rubber block between safety stand and vehicle body when the supporting body is flat.

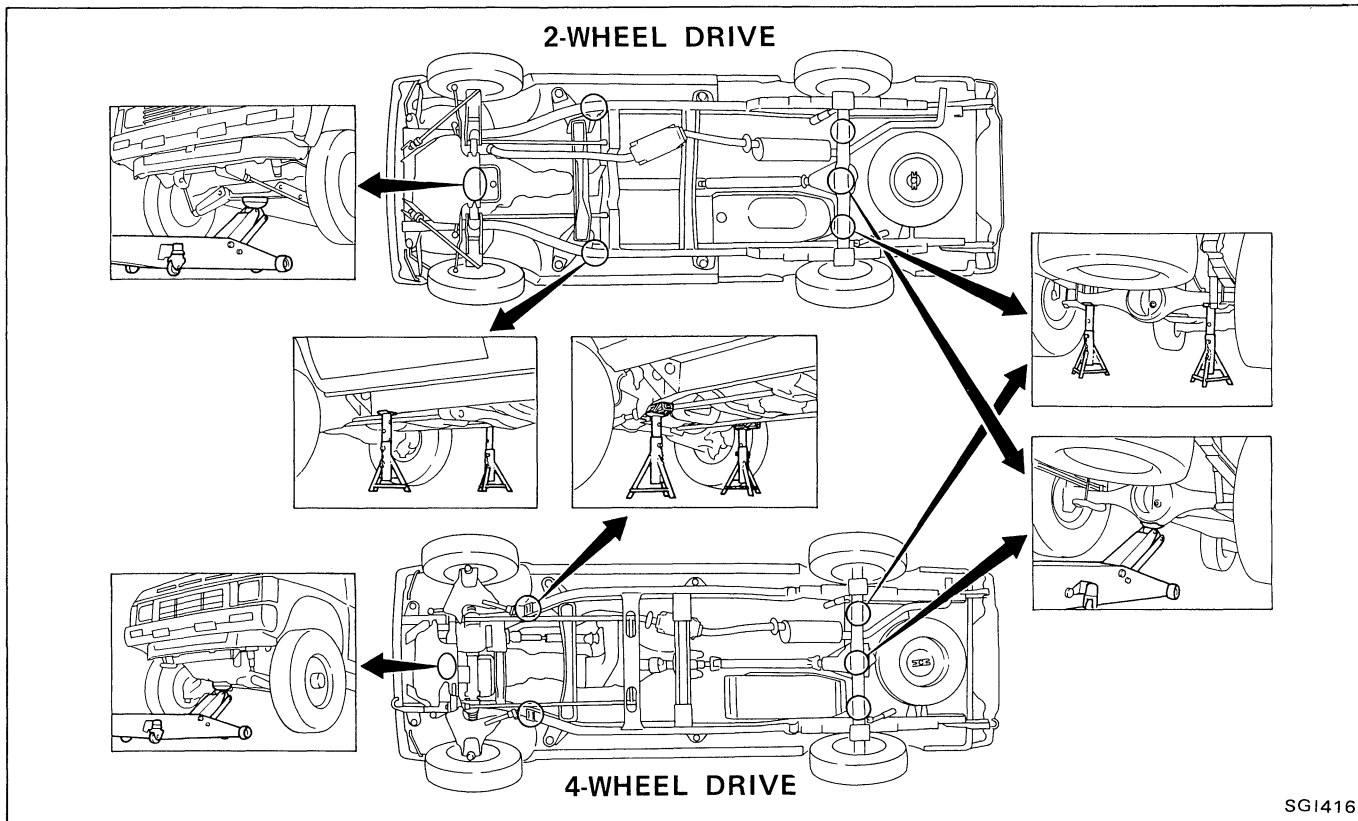

LIFTING POINTS AND TOW TRUCK TOWING

2-pole Lift

WARNING:

When lifting the vehicle, open the lift arms as wide as possible and ensure that the front and rear of the vehicle are well balanced.

When setting the lift arm, do not allow the arm to contact the brake tubes and fuel lines.

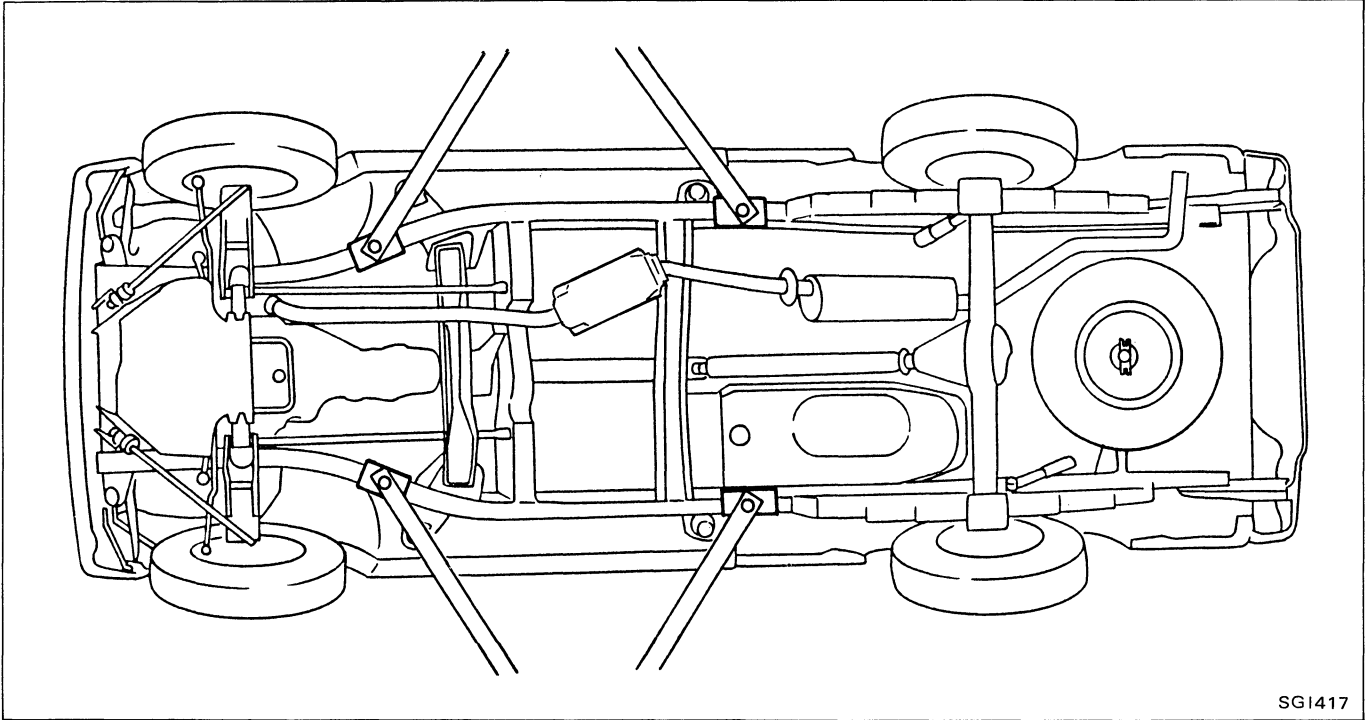

SGI417

Tow Truck Towing

CAUTION:

- All applicable state or Provincial (in Canada) laws and local laws regarding the towing operation must be obeyed.
- It is necessary to use proper towing equipment to avoid possible damage to the vehicle during towing operation. Towing is in accordance with Towing Procedure Manual at dealer.
- Attach safety chains for all towing.
- When towing, make sure that the transmission, steering system and power train are in good order. If any unit is damaged, a dolly must be used.
- When towing with the front wheels on the ground:
Turn the ignition key to the "OFF" position and secure the steering wheel in a straightahead position with a rope or similar device. Never place the ignition key in the "LOCK" position. This will result in damage to the steering lock mechanism.
- When towing with the rear wheels on the ground, release the parking brake and move the gearshift lever to neutral ("N" position).
- For 4-wheel drive model:
Set the free-running hubs to the free position and move both the gearshift and transfer levers to neutral ("N" position).

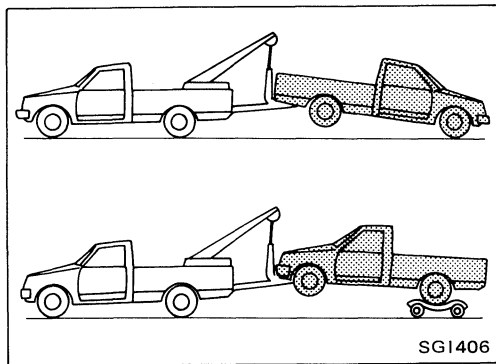

2-WHEEL DRIVE MODELS

NISSAN recommends that vehicle be towed with the driving (rear) wheels off the ground as illustrated.

Towing an automatic transmission model with four wheels on ground or towing with front wheels raised (With rear wheels on ground)

Observe the following restricted towing speeds and distances.

Speed

Below 50 km/h (30 MPH)

Distance

Less than 65 km (40 miles)

If the speed or distance must necessarily be greater, remove the propeller shaft beforehand to prevent damage to the transmission.

LIFTING POINTS AND TOW TRUCK TOWING

Tow Truck Towing (Cont'd)

4-WHEEL DRIVE MODELS

NISSAN recommends that a dolly be used as illustrated when towing 4-wheel drive models.

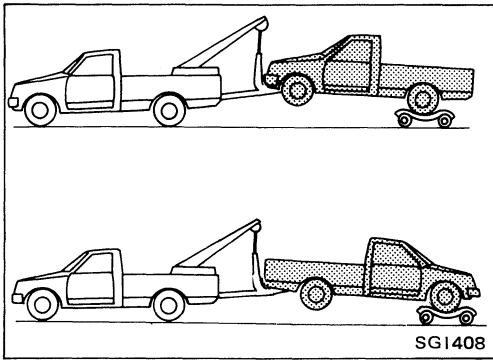

Towing with four wheels on ground or towing with front or rear wheels raised

Observe the following restricted towing speeds and distances.

Speed

Below 50 km/h (30 MPH)

Distance

Less than 65 km (40 miles)

If the speed or distance must necessarily be greater, remove the front and rear propeller shafts beforehand to prevent damage to the transmission.

TOWING POINT

- Never tow the vehicle using only the towing hooks. Use proper towing equipment when towing. Otherwise, the vehicle body will be damaged.
- Always pull the cable straight out from the vehicle. Never pull on the hook at a sideways angle.

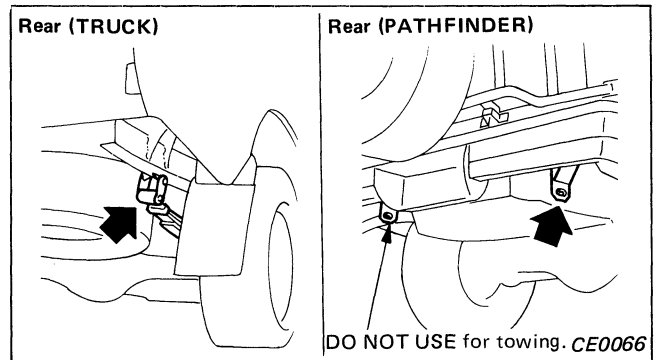
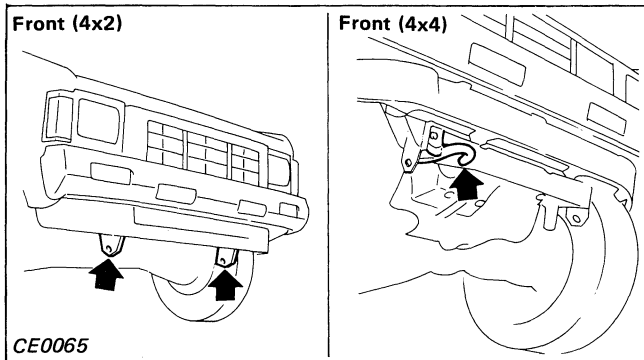

TIGHTENING TORQUE OF STANDARD BOLTS

Grade	Bolt size	Bolt diameter* mm	Pitch mm	Tightening torque (Without lubricant)					
				Hexagon head bolt			Hexagon flange bolt		
				N·m	kg·m	ft·lb	N·m	kg·m	ft·lb
4T	M6	6.0	1.0	5.1	0.52	3.8	6.1	0.62	4.5
	M8	8.0	1.25	13	1.3	9	15	1.5	11
			1.0	13	1.3	9	16	1.6	12
	M10	10.0	1.5	25	2.5	18	29	3.0	22
			1.25	25	2.6	19	30	3.1	22
	M12	12.0	1.75	42	4.3	31	51	5.2	38
1.25			46	4.7	34	56	5.7	41	
M14	14.0	1.5	74	7.5	54	88	9.0	65	
7T	M6	6.0	1.0	8.4	0.86	6.2	10	1.0	7
	M8	8.0	1.25	21	2.1	15	25	2.5	18
			1.0	22	2.2	16	26	2.7	20
	M10	10.0	1.5	41	4.2	30	48	4.9	35
			1.25	43	4.4	32	51	5.2	38
	M12	12.0	1.75	71	7.2	52	84	8.6	62
1.25			77	7.9	57	92	9.4	68	
M14	14.0	1.5	127	13.0	94	147	15.0	108	
9T	M6	6.0	1.0	12	1.2	9	15	1.5	11
	M8	8.0	1.25	29	3.0	22	35	3.6	26
			1.0	31	3.2	23	37	3.8	27
	M10	10.0	1.5	59	6.0	43	70	7.1	51
			1.25	62	6.3	46	74	7.5	54
	M12	12.0	1.75	98	10.0	72	118	12.0	87
1.25			108	11.0	80	137	14.0	101	
M14	14.0	1.5	177	18.0	130	206	21.0	152	

1. Special parts are excluded.
2. This standard is applicable to bolts having the following marks embossed on the bolt head.

*: Nominal diameter

Grade	Mark
4T	4
7T	7
9T	9

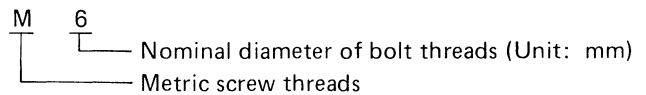

MAINTENANCE

SECTION MA

MA

CONTENTS

PREPARATION	MA- 2
PERIODIC MAINTENANCE	MA- 3
GENERAL MAINTENANCE	MA- 5
LUBRICATION CHART	MA- 8
ENGINE MAINTENANCE	MA- 9
CHASSIS AND BODY MAINTENANCE	MA-26
SERVICE DATA AND SPECIFICATIONS (S.D.S.)	MA-52

PREPARATION

SPECIAL SERVICE TOOLS

For engine maintenance

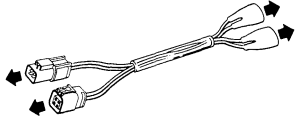
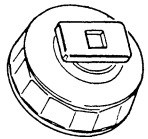
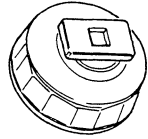
Tool number (Kent-Moore No.) Tool name	Description	Engine Application		
		VG30i	Z24i	
EG11170000 (-) Adapter harness		Measuring idle speed	X	X
KV10105900 (J34274) Oil filter cap wrench		Removing oil filter	X	-
99545R2500 (J22775) Oil filter cap wrench		Removing oil filter	-	X

For chassis and body maintenance

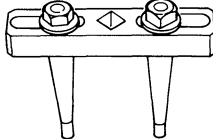
Tool number (Kent-Moore No.) Tool name	Description	
KV40105400 (J36001) Wheel bearing lock nut wrench		Removing or installing wheel bearing lock nut (4WD models)

PERIODIC MAINTENANCE

The following charts show the normal maintenance schedule. Under severe driving conditions, additional or more frequent maintenance will be required. Refer to "Maintenance under severe driving conditions". The periodic maintenance schedule is repeated beyond the last mileage and period shown by returning to the first 15,000 miles (24,000 km) or 12 months.

Emission control system maintenance

MAINTENANCE OPERATION Perform at number of miles, kilometers or months, whichever comes first.	Miles x 1,000 (km x 1,000) Months	MAINTENANCE INTERVAL										Reference page	
		7.5	15	30	45	60	75	90	105	120	VG30i	Z24i	
		(12)	(24)	(48)	(72)	(96)	(121)	(145)	(169)	(193)			
Drive belts				I*		I*		I*		I*	MA-9	MA-17	
Air cleaner filter				Replace every 30,000 miles (48,000 km).							MA-10	MA-18	
Positive crankcase ventilation (P.C.V.) filter	See NOTE (1).			Replace every 30,000 miles (48,000 km).							MA-10	MA-18	
Vapor lines				I*		I*		I*		I*	MA-10	MA-18	
Fuel lines (hoses, piping, connections, etc.)				I*		I*		I*		I*	MA-10	MA-19	
Fuel filter				See NOTE (1).*							MA-11	MA-19	
Engine coolant				R		R		R		R	MA-11	MA-20	
Engine oil		R		Then replace every 7,500 miles (12,000 km) or 6 months.							MA-13	MA-21	
Engine oil filter (Use Nissan PREMIUM type or equivalent.)		R		Then replace every second oil change.							MA-13	MA-22	
Spark plugs				Replace every 30,000 miles (48,000 km).							MA-14	MA-23	
Ignition wires				Inspect every 3 years.*							MA-15	MA-23	
Intake & exhaust valve clearance (Z24i engine only)			A	A	A	A	A	A	A	A	—	MA-24	
	Except the below			I*		A		I*		A	MA-15	MA-25	
Idle rpm	For California models			I*		I*		I*		I*	MA-15	MA-25	
Timing belt (VG30i engine only)				Replace every 60,000 miles (96,000 km).							EM-20	—	

Chassis and body maintenance

MAINTENANCE OPERATION Perform at number of miles, kilometers or months, whichever comes first.	Miles x 1,000 (km x 1,000) Months	MAINTENANCE INTERVAL										Reference page	
		15	30	45	60	75	90	105	120	VG30i	Z24i		
		(24)	(48)	(72)	(96)	(121)	(145)	(169)	(193)				
Brake lines & hoses		I	I	I	I	I	I	I	I	I	MA-41		
Brake pads, discs, drums & linings		I	I	I	I	I	I	I	I	I	MA-41, 42		
Manual and automatic transmission, transfer & differential gear oil (exc. L.S.D.)		I	I	I	I	I	I	I	I	I	MA-27, 29, 30		
Limited-slip differential (L.S.D.) gear oil		I	R	I	R	I	R	I	R		MA-30, 31		
Steering gear (box) & linkage, (steering damper 4x4), axle & suspension parts			I		I		I		I		MA-31, 49		
Front drive shaft boots (4x4)			I	I	I	I	I	I	I	I	MA-40		
Steering linkage ball joints & front suspension ball joints					I				I		MA-32, 49		
Front wheel bearing grease (4x2)				I		I		I		I	MA-32		
Front wheel bearing grease (4x4)				I	R	I	R	I	R	I	MA-34		
Exhaust system			I	I	I	I	I	I	I	I	MA-26		

NOTE: (1) If vehicle is operated under extremely adverse weather conditions or in areas where ambient temperatures are either extremely low or extremely high, the filters might become clogged. In such an event, replace them immediately.
 (2) Maintenance items and intervals with "*" are recommended by NISSAN for reliable vehicle operation. The owner need not perform such maintenance in order to maintain the emission warranty or manufacturer recall liability. Other maintenance items and intervals are required.

Abbreviations: A = Adjust R = Replace I = Inspect. Correct or replace if necessary.

PERIODIC MAINTENANCE

MAINTENANCE UNDER SEVERE DRIVING CONDITIONS

The maintenance intervals shown on the preceding pages are for normal operating conditions. If the vehicle is mainly operated under severe driving conditions as shown below, more frequent maintenance is required to be performed on the following items as shown in the table.

Severe driving conditions

- A — Repeated short trips less than 5 miles (8 km) and outside temperatures remain below freezing
- B — Extensive idling and/or low speed driving for a long distance such as police, taxi or door-to-door delivery use
- C — Driving in dusty conditions
- D — Driving on rough, muddy, or salt spread roads
- E — Towing a trailer, using a camper or a car-top carrier
- F — Frequent driving in water

Driving condition	Maintenance item	Maintenance operation	Maintenance interval	Reference page	
				VG30i	Z24i
. . . C . . .	Air cleaner filter	R	More frequently	MA-10	MA-18
	Air induction valve filter	R	Every 30,000 miles (48,000 km)	MA-10	MA-18
A B C D E .	Engine oil & oil filter	R	Every 3,000 miles (5,000 km) or 3 months	MA-13	MA-21, 22
A . C D E .	Brake pads, discs, drums & lining	I	Every 7,500 miles (12,000 km)	MA-41, 42	
. . . D E .	Manual and automatic transmission, transfer & differential gear oil (exc. L.S.D.)	R	Every 30,000 miles (48,000 km) or 24 months	MA-27, 29, 31	
	Limited-slip differential (L.S.D.) gear oil	R	Every 15,000 miles (24,000 km) or 12 months		
. . . D . .	Steering gear (box) & linkage, (steering damper 4x4), axle & suspension parts, & (front drive shaft boots 4x4)	I		MA-31, 40	
. . C D . . .	Steering linkage ball joints & front suspension ball joints	I	Every 7,500 miles (12,000 km) or 6 months	MA-32, 49	
. . . D E .	Propeller shaft(s) (4x4)	I		MA-30	
A . . D E .	Exhaust system	I		MA-26	
. F	Front wheel bearing grease & free-running hub grease (4x4)	I	Every 3,000 miles (5,000 km) or 3 months	MA-34, 39	

Maintenance operations: I = Inspect. Correct or replace if necessary R = Replace

Maintenance for off-road driving (**4x4** only)

Whenever you drive off-road through sand, mud or water as deep as the wheel hub, more frequent maintenance may be required of the following items:

- ▲ Brake pads and discs
- ▲ Brake lining and drums
- ▲ Brake lines and hoses
- ▲ Wheel bearing grease and free-running hub grease
- ▲ Differential, transmission and transfer oil
- ▲ Steering linkage
- ▲ Propeller shafts and front drive shafts
- ▲ Air cleaner filter
- ▲ Clutch housing (Check water entry. Refer to MA-27)

GENERAL MAINTENANCE

General maintenance includes those items which should be checked during the normal day-to-day operation of the vehicle. They are essential if the vehicle is to continue operating properly. The owners can perform the checks and inspections themselves or they can have their NISSAN dealers do them for a nominal charge.



Item	Reference item in MA section
OUTSIDE THE VEHICLE	
The maintenance items listed here should be performed from time to time, unless otherwise specified.	
Tires Check the pressure with a gauge periodically when at a service station, including the spare, and adjust to the specified pressure if necessary. Check carefully for damage, cuts or excessive wear.	● CHECKING TIRE CONDITION
Wheel nuts When checking the tires, make sure no nuts are missing, and check for any loose nuts. Tighten if necessary.	● WHEEL NUT
Tire rotation Tires should be rotated every 12,000 km (7,500 miles).	● TIRE ROTATION
Wheel alignment and balance If the vehicle should pull to either side while driving on a straight and level road, or if you detect uneven or abnormal tire wear, there may be a need for wheel alignment. If the steering wheel or seat vibrates at normal highway speeds, wheel balancing may be needed.	● CHECKING TIRE CONDITION Abnormal tire wear ● CHECKING FRONT WHEEL ALIGNMENT ● WHEEL INSPECTION ● BALANCING WHEELS
Windshield glass Check for abrasions or scratches.	—
Windshield wiper blades Check for cracks or wear if they do not wipe properly.	—
Doors and engine hood Check that all doors and the engine hood operate properly. Also ensure, that all latches lock securely. Lubricate if necessary. Make sure that the secondary latch keeps the hood from opening when the primary latch is released. When driving in areas using road salt or other corrosive materials, check lubrication frequently.	● LUBRICATING LOCKS, HINGES AND HOOD LATCH
INSIDE THE VEHICLE	
The maintenance items listed here should be checked on a regular basis, such as when performing periodic maintenance, cleaning the vehicle, etc.	
Lights Make sure that the headlights, stop lights, tail lights, turn signal lights, and other lights are all operating properly and installed securely. Also check headlight aim.	—
Warning lights and buzzers/chimes Make sure that all warning lights and buzzers/chimes are operating properly.	—
Horn Make sure it operates properly.	—
Windshield wiper and washer Check that the wipers and washer operate properly and that the wipers do not streak.	—

GENERAL MAINTENANCE

Item	Reference item in MA section
Windshield defroster Check that the air comes out of the defroster outlets properly and in sufficient quantity when operating the heater or air conditioner.	—
Rear view mirror Make sure that it is secure and clean.	—
Sun visors Make sure that they can be moved freely and are secure.	—
Steering wheel Check for changes in the steering condition, such as excessive free play, hard steering or strange noises.	Specification Free play: Less than 35 mm (1.38 in)
Seats Check seat position controls such as seat adjusters, seatback recliner, etc. to ensure they operate smoothly and that all latches lock securely in every position. Check that the head restraints move up and down smoothly and that the locks (if so equipped) hold securely in all latched positions.	—
Seat belts Check that all parts of the seat belt system (e.g. buckles, anchors, adjusters and retractors) operate properly and smoothly, and are installed securely. Check the belt webbing for cuts, fraying, wear or damage.	<ul style="list-style-type: none"> ● INSPECTING SEAT BELTS, BUCKLES ANCHORS, RETRACTORS AND ADJUSTER
Accelerator pedal Check the pedal for smooth operation and make sure the pedal does not catch or require uneven effort. Keep the floor mats away from the pedal.	—
Clutch pedal Make sure the pedal operates smoothly and check that it has the proper free travel.	<ul style="list-style-type: none"> ● CHECKING CLUTCH PEDAL OPERATION
Brakes Check that the brakes do not pull the vehicle to one side when applied.	—
Brake pedal Check the pedal for smooth operation and make sure it has the proper distance under it when depressed fully. Check the brake booster function.	<ul style="list-style-type: none"> ● CHECKING FOOT BRAKE PEDAL OPERATION ● CHECKING BRAKE BOOSTER FUNCTION
Parking brake Check that the lever has the proper travel and confirm that your vehicle is held securely on a fairly steep hill with only the parking brake applied.	<ul style="list-style-type: none"> ● CHECKING PARKING BRAKE
Automatic transmission "Park" mechanism Check that the lock release button on the selector lever operates properly and smoothly. On a fairly steep hill check that your vehicle is held securely with the selector lever in the "P" position without applying any brakes.	—

GENERAL MAINTENANCE

Item	Reference item in MA section
UNDER THE HOOD AND VEHICLE	
The maintenance items listed here should be checked periodically e.g. each time you check the engine oil or refuel.	
Windshield washer fluid Check that there is adequate fluid in the tank.	—
Engine coolant level Check the coolant level when the engine is cold.	● CHANGING ENGINE COOLANT
Radiator and hoses Check the front of the radiator and clean off any dirt, insects, leaves, etc., that may have accumulated. Make sure the hoses have no cracks, deformation, rot or loose connections.	—
Brake and clutch fluid levels Make sure that the brake and clutch fluid levels are between the "MAX" and "MIN" lines on the reservoir.	● CHECKING CLUTCH SYSTEM ● CHECKING BRAKE FLUID LEVEL & LEAKS
Engine drive belts Make sure that no belt is frayed, worn, cracked or oily.	● CHECKING DRIVE BELT
Engine oil level Check the level after parking the vehicle on a level spot and turning off the engine.	—
Power steering fluid level and lines Check the level when the fluid is cold and the engine is turned off. Check the lines for proper attachment, leaks, cracks, etc.	● CHECKING POWER STEERING SYSTEM FLUID & LINES
Automatic transmission fluid level Check the level after putting the selector lever in "P" with the engine idling.	● CHECKING AUTOMATIC TRANSMISSION FLUID
Battery Check the fluid level in each cell. It should be between "MAX" and "MIN" lines.	—
Exhaust system Make sure there are no loose supports, cracks or holes. If the sound of the exhaust seems unusual or there is a smell of exhaust fumes, immediately locate the trouble and correct it.	● INSPECTING EXHAUST SYSTEM
Underbody The underbody is frequently exposed to corrosive substances such as those used on icy roads or to control dust. It is very important to remove these substances, otherwise rust will form on the floor pan, frame, fuel lines and around the exhaust system. At the end of winter, the underbody should be thoroughly flushed with plain water, being careful to clean those areas where mud and dirt may accumulate.	—
Fluid leaks Check under the vehicle for fuel, oil, water or other fluid leaks after the vehicle has been parked for a while. Water dripping from the air conditioner after use is normal. If you should notice any leaks or if gasoline fumes are evident, check for the cause and have it corrected immediately.	● CHECKING CLUTCH SYSTEM ● INSPECTING MANUAL TRANSMISSION OIL ● INSPECTING AUTOMATIC TRANSMISSION FLUID ● INSPECTING TRANSFER OIL ● INSPECTING DIFFERENTIAL GEAR OIL ● INSPECTING BRAKE LINES & HOSES ● CHECKING POWER STEERING SYSTEM FLUID & LINE

	CHANGE
	CHECK

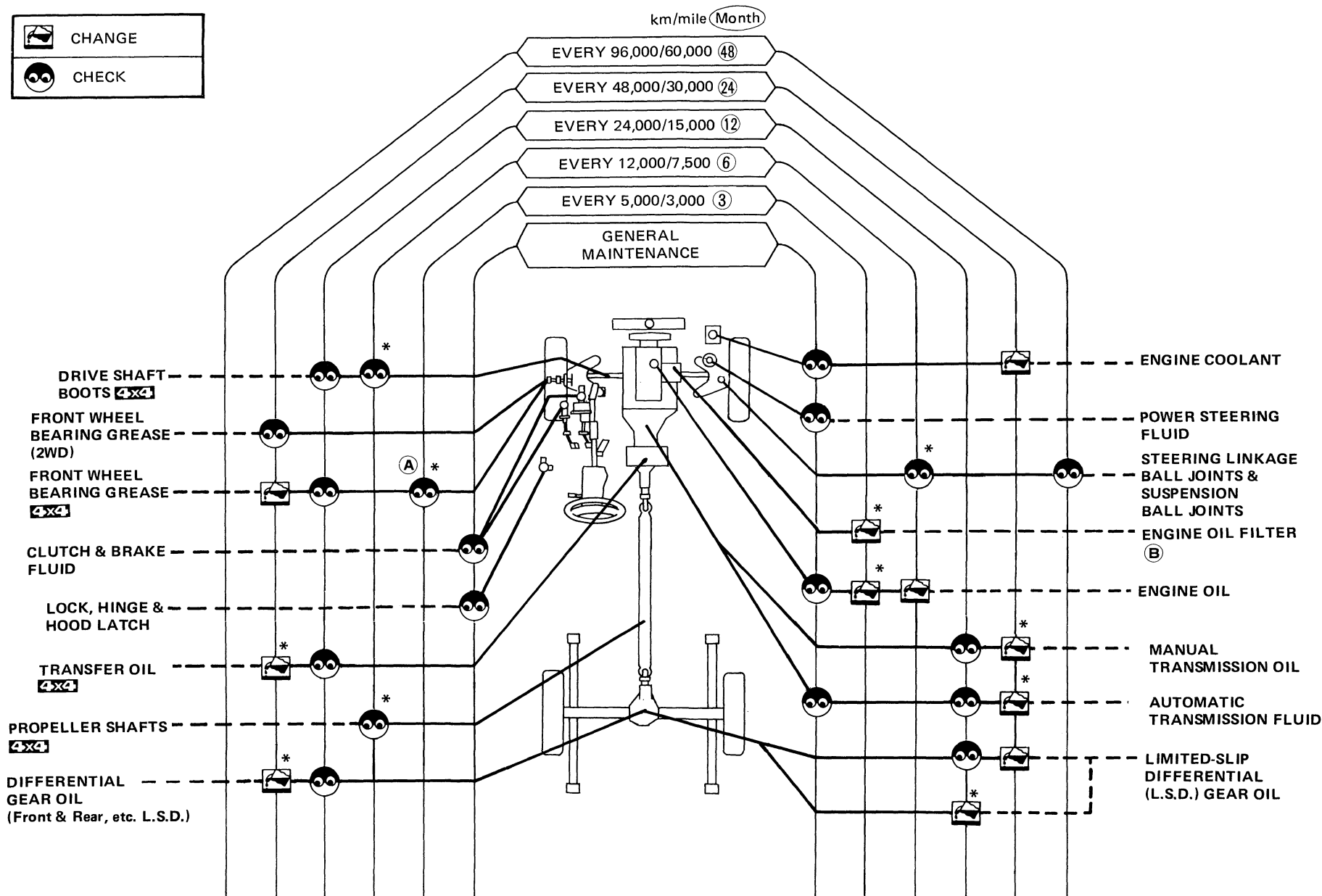

* : Maintenance under severe driving conditions

(A) Including free-running hub grease.

(B) Replace at the first oil change and then every second oil change.

Drive Belt Inspection

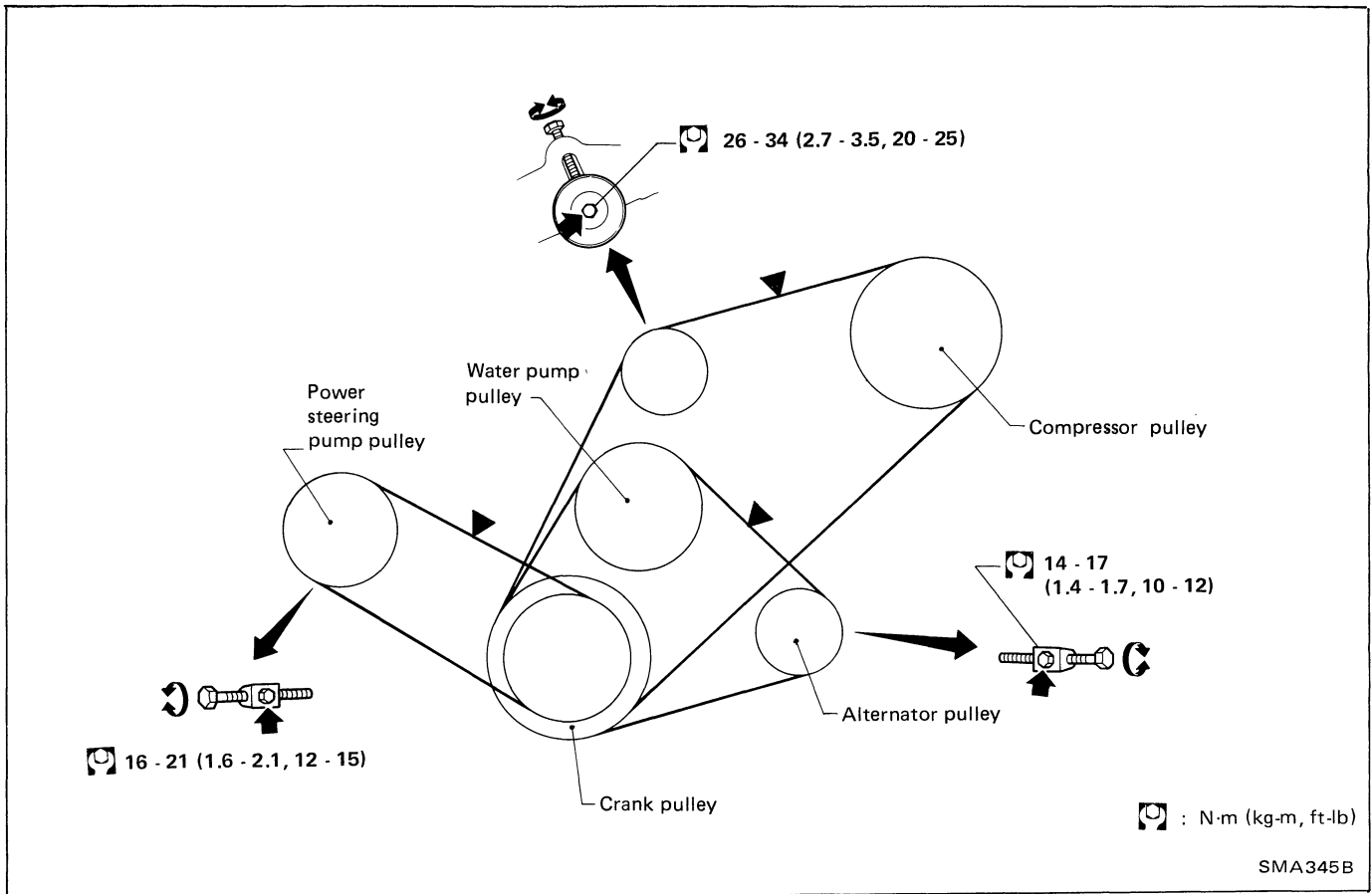

1. Inspect for cracks, fraying, wear or oil adhesion. If necessary, replace with new one.

The belt should not touch the bottom of the pulley groove.

2. Inspect drive belt deflections by pushing on the belt midway between pulleys.

Adjust if belt deflections exceed the limit.

Belt deflection:

Unit: mm (in)

	Used belt deflection		Set deflection of new belt
	Limit	Adjusted deflection	
Alternator	12 (0.47)	6 - 8 (0.24 - 0.31)	5 - 7 (0.20 - 0.28)
Air conditioner compressor	16 (0.63)	9 - 11 (0.35 - 0.43)	7 - 9 (0.28 - 0.35)
Power steering oil pump	17 (0.67)	11 - 13 (0.43 - 0.51)	9 - 11 (0.35 - 0.43)
Applied pushing force	98 N (10 kg, 22 lb)		

Inspect drive belt deflections when engine is cold. If engine is hot, check deflections in 30 minutes or more.

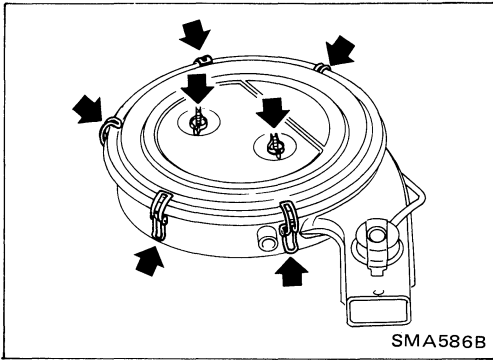

Replacing Air Cleaner Filter

The viscous paper type air cleaner filter does not require any cleaning operation between renewals.

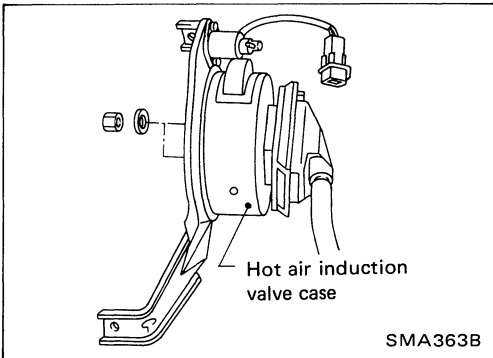

Replacing Air Induction Valve Filter

Remove hot air induction valve case, and take out air induction valve filter. Then install new air induction valve filter.

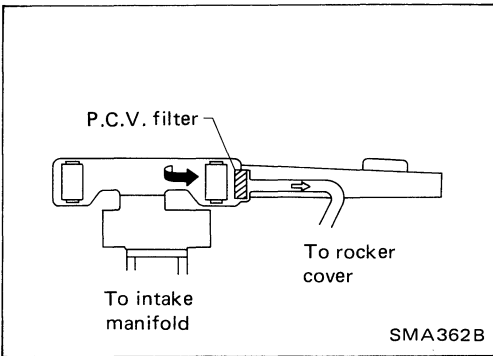

Positive Crankcase Ventilation (P.C.V.) Filter Replacement

Remove air cleaner cover and replace P.C.V. filter.

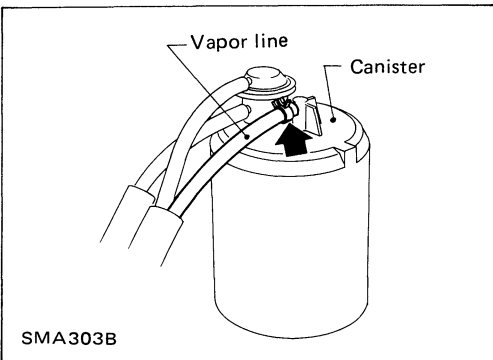

Vapor Line Inspection

1. Visually inspect vapor lines for proper attachment, cracks, damage, loose connections, chafing and deterioration.
2. Inspect vacuum relief valve of fuel tank filler cap for clogging, sticking, etc.

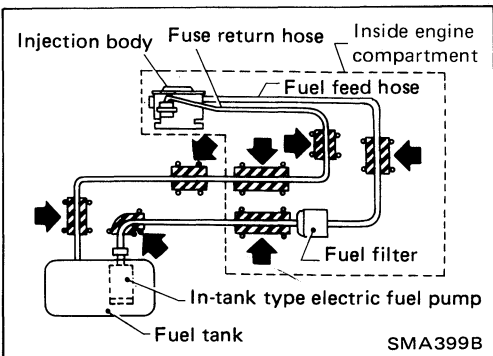

Fuel Line Inspection

Inspect fuel lines and tank for proper attachment, leaks, cracks, damage, loose connections, chafing and deterioration. If necessary, repair or replace faulty parts.

ENGINE MAINTENANCE

Fuel Line Inspection (Cont'd)

CAUTION:

Tighten high-pressure rubber hose clamp so that clamp end is 3 mm (0.12 in) from hose end.

Ensure that screw does not contact adjacent parts.

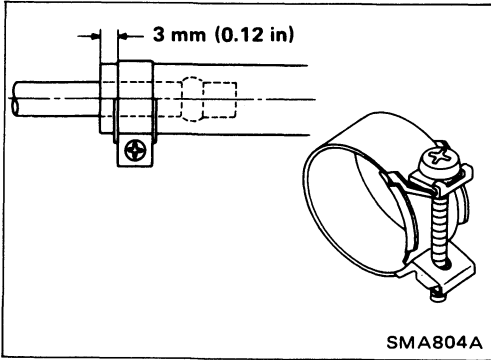

Fuel Filter Replacement

WARNING:

Before removing fuel filter, release fuel pressure from fuel line to eliminate danger.

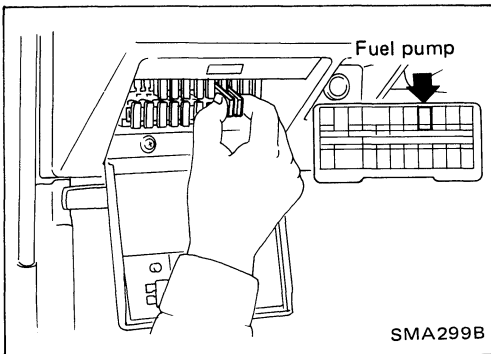

1. Remove fuse for fuel pump.
2. Start engine.
3. After engine stalls, crank engine two or three times to make sure that fuel pressure is released.
4. Turn ignition switch off and install fuse for fuel pump.

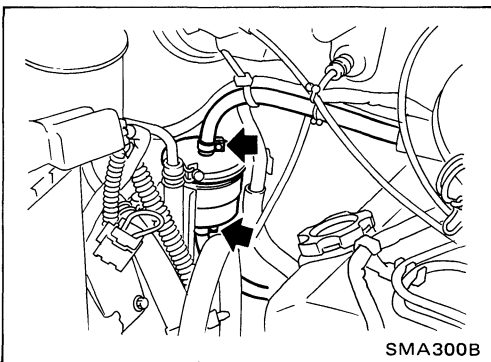

5. Loosen fuel hose clamps.
6. Replace fuel filter.
 - Be careful not to spill fuel in engine compartment. Place a rag to absorb fuel.
 - Use high-pressure type fuel filter. Do not use a synthetic resinous fuel filter.

Changing Engine Coolant

WARNING:

To avoid the danger of being scalded, never attempt to change the coolant when the engine is hot.

1. Move heater "TEMP" control lever all the way to "HOT" position.

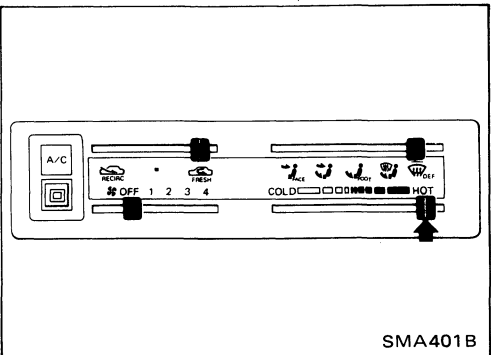

Changing Engine Coolant (Cont'd)

2. Open drain cock at the bottom of radiator, and remove radiator cap.

Be careful not to allow coolant to contact drive belts.

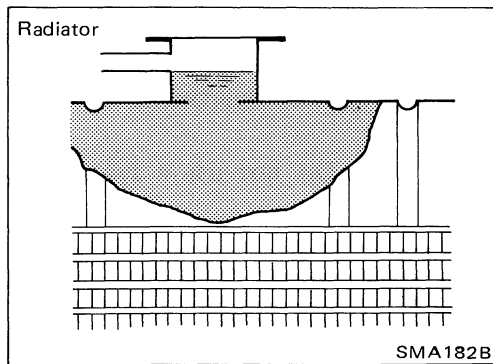
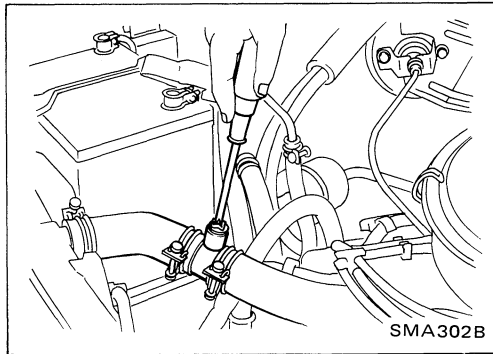
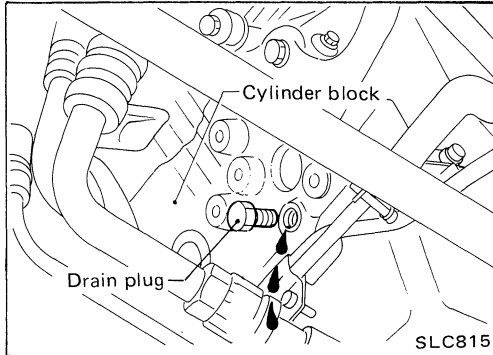
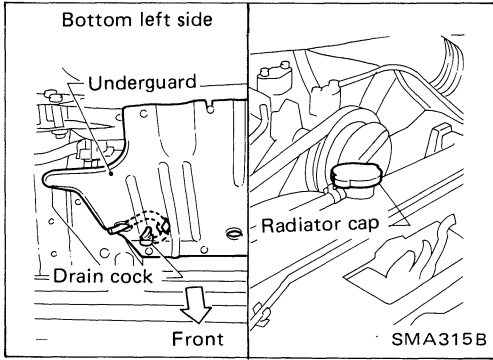

3. Remove cylinder block drain plug behind the alternator to drain coolant from cylinder block.
4. Close drain cock and tighten drain plug securely.
5. Fill radiator with water, then warm up engine.
6. Stop engine and wait until it cools down.
7. Repeat step 2 through step 6 two or three times.
8. Drain water.
- **Apply sealant to the thread of drain plug.**
 ⚙ : 34 - 44 N·m
 (3.5 - 4.5 kg-m, 25 - 33 ft-lb)
9. Open air relief plug.

10. Fill radiator with coolant up to filler opening.
 Follow instructions attached to anti-freeze container for mixing ratio of anti-freeze to water.

Coolant capacity: (Without reservoir tank)

9.9 ℓ (10-1/2 US qt, 8-3/4 Imp qt)

Reservoir tank:

0.6 ℓ (5/8 US qt, 1/2 Imp qt)

Pour coolant through coolant filler neck slowly to allow air in system to escape.

11. Tighten air relief plug.

ENGINE MAINTENANCE

Changing Engine Coolant (Cont'd)

12. Fill reservoir tank with coolant up to "MAX" level.
13. Run engine at approximately 2,000 rpm for about one minute.
14. Stop engine and cool it down, then refill radiator and reservoir tank.

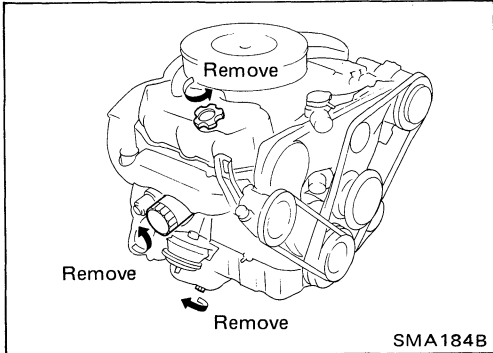
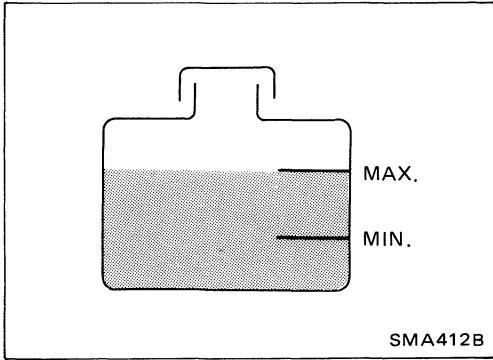

Changing Engine Oil

WARNING:

Be careful not to burn yourself, as engine oil is hot.

1. Warm up engine, and check for oil leakage from engine components.
2. Remove oil filler cap and drain plug.
3. Drain oil and refill with new engine oil.

Oil capacity (Approximately):

Unit: ℓ (US qt, Imp qt)

	2WD	4WD
With oil filter change	4.0 (4-1/4, 3-1/2)	3.4 (3-5/8, 3)
Without oil filter change	3.6 (3-7/8, 3-1/8)	3.0 (3-1/8, 2-5/8)

CAUTION:

- a. Be sure to clean drain plug and install with new washer.

 : Drain plug

29 - 39 N.m (3.0 - 4.0 kg-m, 22-29 ft-lb)

- b. Use recommended engine oil.

Refer to GI section.

4. Check oil level.
5. Start engine. Check area around drain plug and oil filter for any sign of oil leakage.
6. Run engine for a few minutes, then turn it off. After several minutes, check oil level.

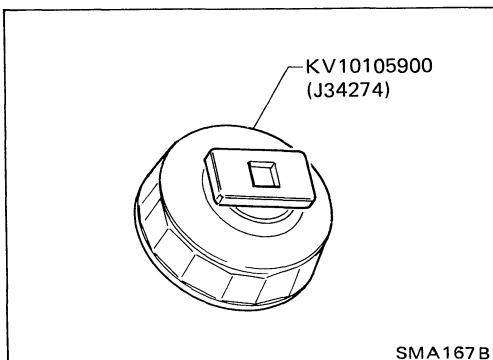
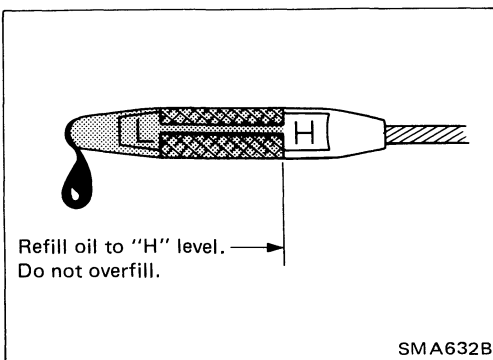

Oil Filter Replacement

1. Remove oil filter with Tool.

WARNING:

Be careful not to burn yourself, as engine and engine oil are hot.

Oil Filter Replacement (Cont'd)

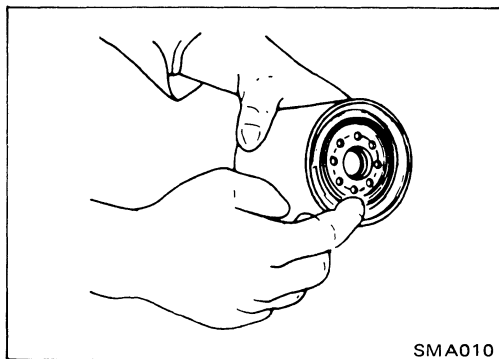

SMA010

2. Before installing new oil filter, wipe clean oil filter mounting surface on cylinder block, and smear a little engine oil on rubber seal of oil filter.

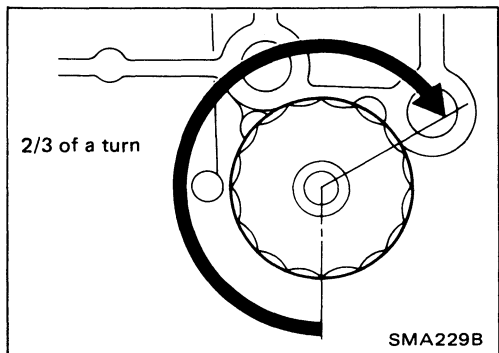

SMA229B

3. Screw oil filter on until a slight resistance is felt, then tighten an additional more than 2/3 turn.

4. Add engine oil.

Refer to Changing Engine Oil.

Spark Plug Replacement

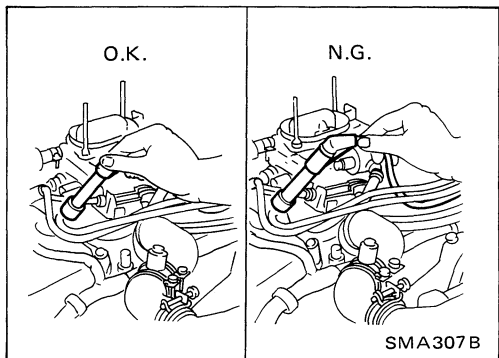

SMA307B

1. Remove air cleaner.
2. Disconnect ignition wires from spark plugs by pulling on boots. Do not pull on wires.

CAUTION:

Before removing spark plug, be sure there is no foreign substance in the hollow area around spark plug.

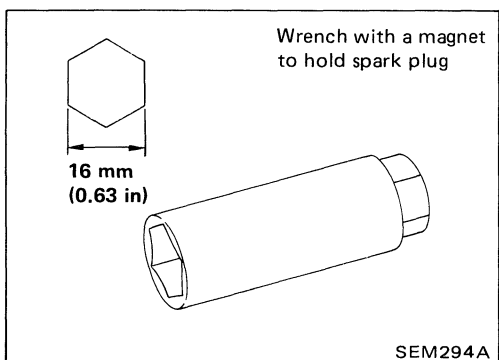

SEM294A

3. Remove spark plugs with suitable spark plug wrench.

Spark plug:

Standard type	BCPR5ES-11
Hot type	BCPR4ES-11
Cold type	BCPR6ES-11

Spark Plug Replacement (Cont'd)

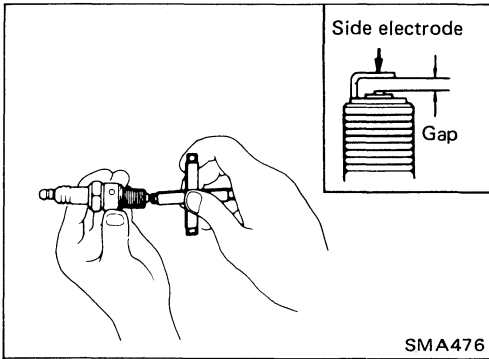

4. Check new spark plug gap.
Gap: 1.0 - 1.1 mm (0.039 - 0.043 in)
5. Install spark plugs. Reconnect ignition wires according to Nos. indicated on them.
 : **Spark plug**
20 - 29 N·m (2.0 - 3.0 kg-m, 14 - 22 ft-lb)

Ignition Wire (High Tension Wire) Inspection

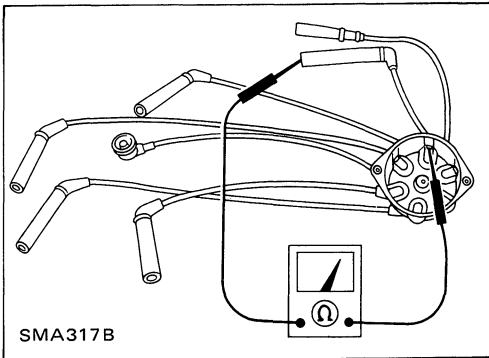

1. Inspect ignition wires for cracks, damage, burned terminals and proper fit.
2. Measure the resistance of ignition wires by shaking it and checking for intermittent breaks.
Resistance: Less than 30 kΩ
3. If N.G., replace with new one.

Idle Speed Inspection

CAUTION:

Do not attempt to screw idle adjusting screw down completely. Doing so could cause damage to tip, which in turn will tend to cause malfunctions.

Preparation

1. Set shift lever in "Neutral" position (in "N" or "P" position for the automatic transmission). Engage parking brake and lock both front and rear wheels with wheel chocks.
2. Turn off air conditioner and headlamps.
3. Keep front wheels straightahead.

WARNING:

Depress brake pedal while racing the engine to prevent forward surge of vehicle.

ENGINE MAINTENANCE

Idle Speed Inspection (Cont'd)

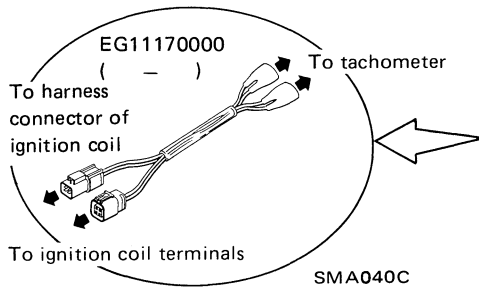

PREPARATION:

- Warm up engine until water temperature indicator points to the middle of gauge.
- Attach Tool (adapter harness) between ignition coil primary winding terminals and harness connector. Then connect tachometer to adapter harness.

Start engine

Run engine at about 2,000 rpm for about 2 minutes under no-load.

Race engine (2,000 - 3,000 rpm) 2 or 3 times under no-load, then run engine for one minute at idle speed.

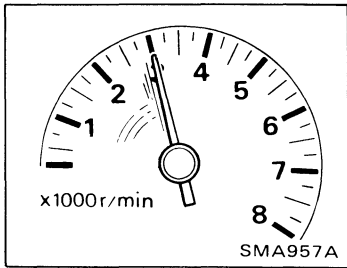

Make sure to engage parking brake and move A/T shift lever to "D" position. Check idle speed.

For M/T model
800±50 rpm

For A/T model (in "D" position)
700±50 rpm

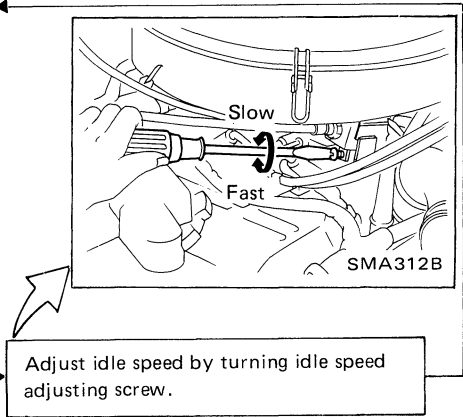

O.K. → END

N.G. → Adjust idle speed by turning idle speed adjusting screw.

- Disconnect adapter harness connector and connect ignition coil harness connector to ignition coil.
- After inspection and adjustment have been made, move shift lever to "N" or "P" position.

Drive Belt Inspection

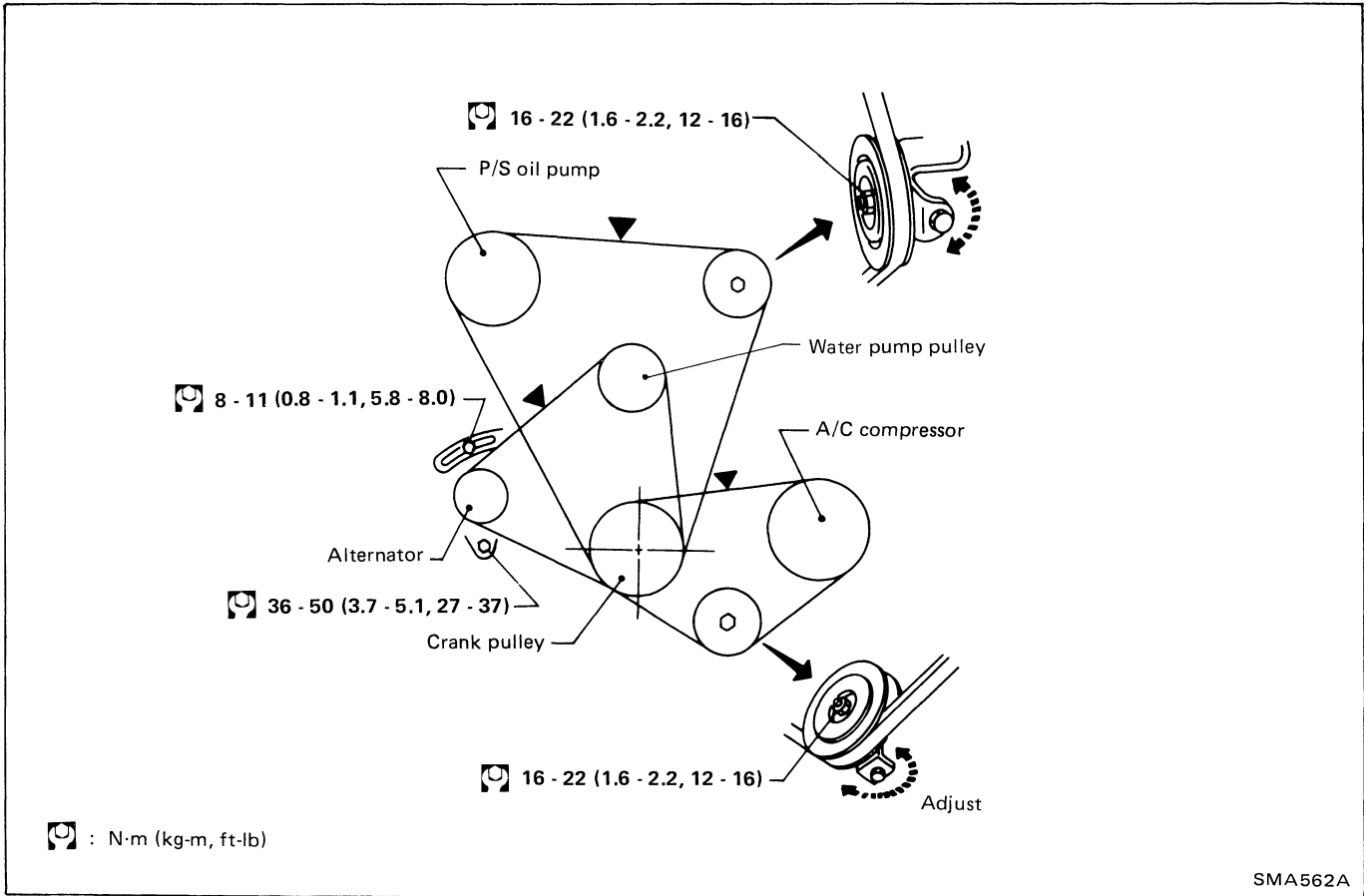

1. Inspect for cracks, fraying, wear and oil adhesion. If necessary, replace with new one.

This belts should not touch the bottom of the pulley groove.

2. Inspect drive belt deflections by pushing on the belt midway between pulleys.

Adjust if belt deflections exceed the limit.

Belt deflection:

Unit: mm (in)

	Used belt deflection		Set deflection of new belt
	Limit	Adjusted deflection	
Alternator	16 (0.63)	9 - 11 (0.35 - 0.43)	7 - 9 (0.28 - 0.35)
Air conditioner compressor	13 (0.51)	8 - 10 (0.31 - 0.39)	6 - 8 (0.24 - 0.31)
Power steering oil pump	16 (0.63)	10 - 12 (0.39 - 0.47)	8 - 10 (0.31 - 0.39)
Applied pushing force	98 N (10 kg, 22 lb)		

Inspect drive belt deflections when engine is cold. If engine is hot, check deflections in 30 minutes or more.

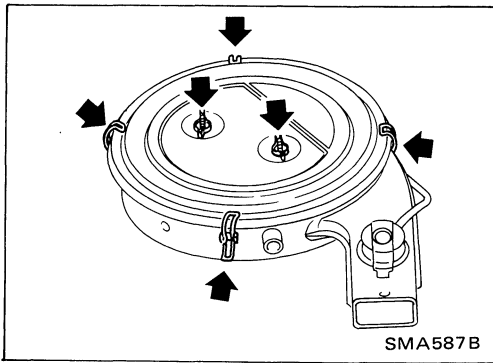

Replacing Air Cleaner Filter

The viscous paper type air cleaner filter does not require any cleaning operation between renewal.

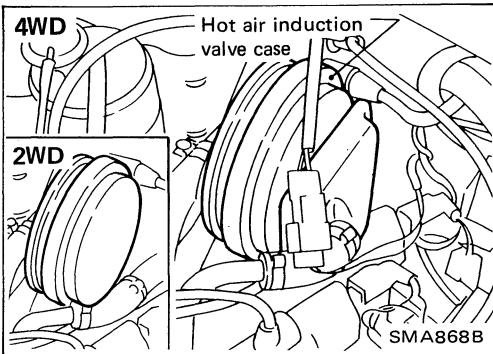

Replacing Air Induction Valve (A.I.V) Filter

Remove air induction valve case from vehicle and take out air induction valve filter. Then install new air induction valve filter.

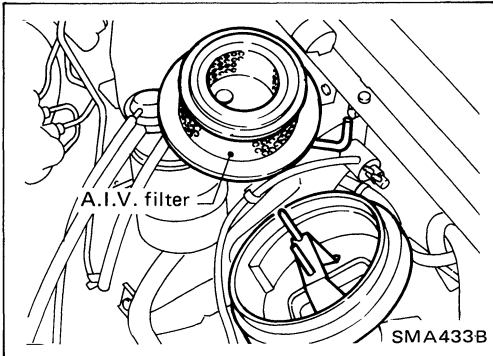

Positive Crankcase Ventilation (P.C.V.) Filter Replacement

Remove air cleaner cover and replace P.C.V. filter.

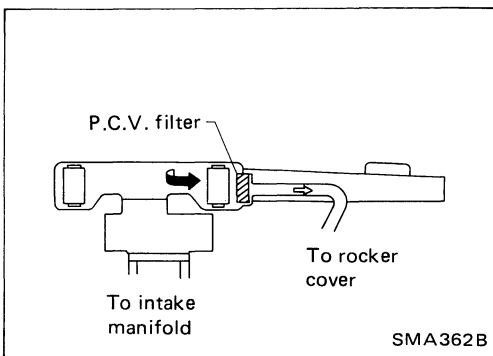

Vapor Line Inspection

1. Visually inspect vapor lines for proper attachment, cracks, damage, loose connections, chafing and deterioration.
2. Inspect vacuum relief valve of fuel tank filler cap for clogging, sticking, etc.

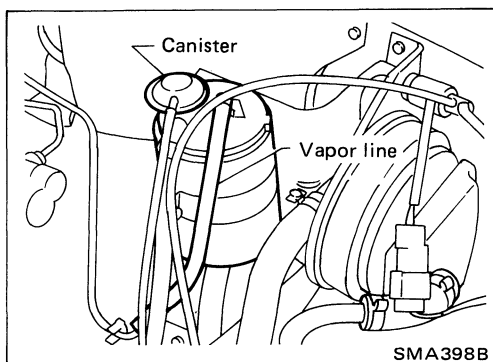

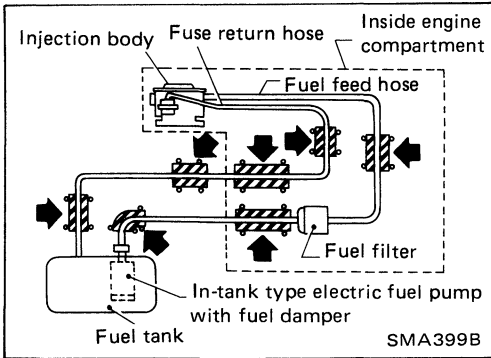

Fuel Line Inspection

Inspect fuel lines and tank for proper attachment, leaks, cracks, damage, loose connections, chafing and deterioration. If necessary, repair or replace faulty parts.

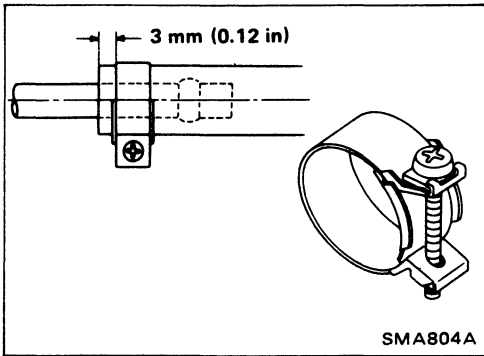

CAUTION:

Tighten high-pressure rubber hose clamp so that clamp end is 3 mm (0.12 in) from hose end. Ensure that screw does not contact adjacent parts.

Fuel Filter Replacement

WARNING:

Before removing fuel filter, release fuel pressure from fuel line to eliminate danger.

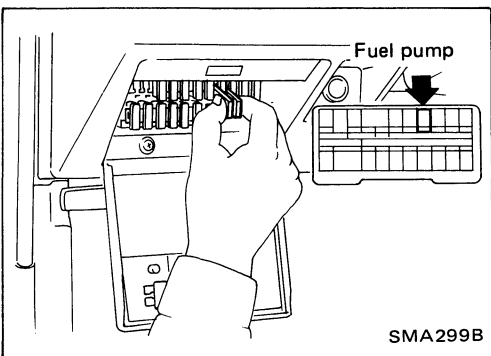

1. Remove fuse for fuel pump.
2. Start engine.
3. After engine stalls, crank engine two or three times to make sure that fuel pressure is released.
4. Turn ignition switch off and install fuse for fuel pump.

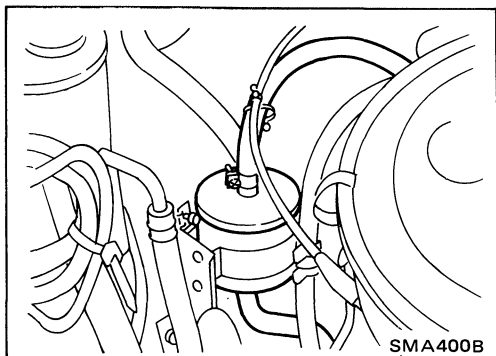

5. Loosen fuel hose clamps.
6. Replace fuel filter.
 - Be careful not to spill fuel over engine compartment. Place a rag to absorb fuel.
 - Use high-pressure type fuel filter. Do not use a synthetic resinous fuel filter.

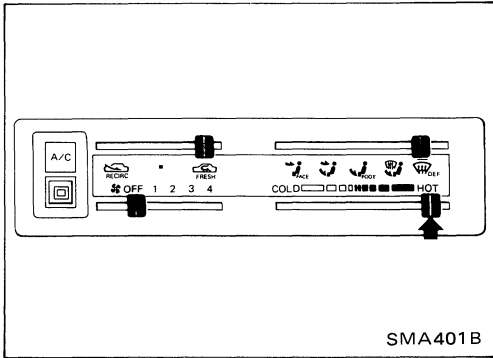

Changing Engine Coolant

WARNING:

To avoid the danger of being scalded, never attempt to change the coolant when the engine is hot.

1. Move heater "TEMP" control lever all the way to "HOT" position.

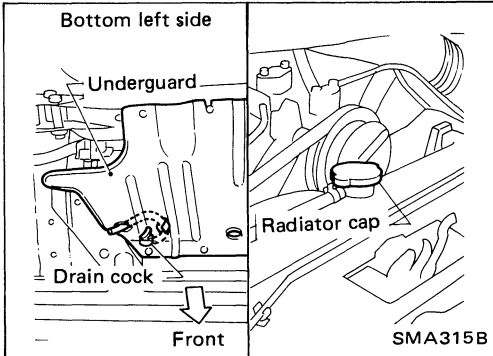

2. Open drain cock at the bottom of radiator, and remove radiator cap.

- Be careful not to allow coolant to contact drive belts.

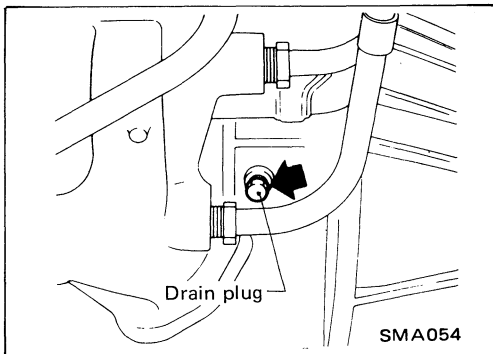

3. Remove cylinder block drain plug located at left rear of cylinder block.

4. Close drain cock and tighten drain plug securely.

5. Fill radiator with water and warm up engine.

6. Stop engine and wait until it cools down.

7. Repeat step 2 through step 6 two or three times.

8. Drain water.

- Apply sealant to the thread of drain plug.

: 29 - 39 N·m
(3.0 - 4.0 kg·m, 22 - 29 ft·lb)

9. Fill radiator with coolant up to filler opening. Follow instructions attached to anti-freeze container for mixing ratio of anti-freeze to water.

Coolant capacity: (Without reservoir tank)

8.2 ℓ (8-5/8 US qt, 7-1/4 Imp qt)

Reservoir tank:

0.6 ℓ (5/8 US qt, 1/2 Imp qt)

Pour coolant through coolant filler neck slowly to allow air in system to escape.

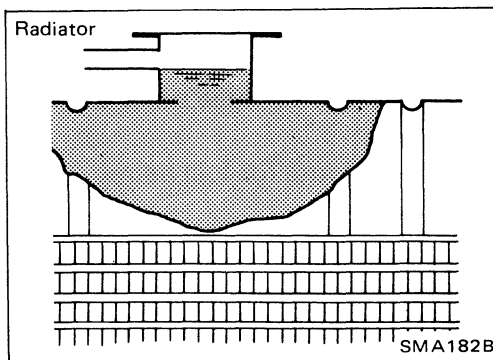

10. Fill reservoir tank with coolant up to "MAX" level.

11. Run engine at approximately 2,000 rpm for about one minute.

12. Stop engine and cool it down, then refill radiator and reservoir tank.

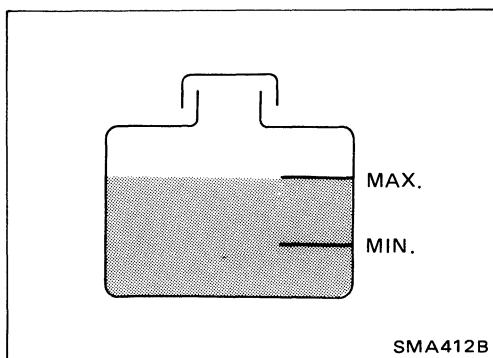

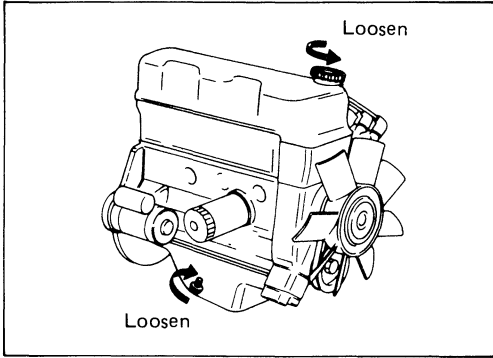

Changing Engine Oil

WARNING:

Be careful not to burn yourself, as the engine oil may be hot.

1. Warm up engine, and check for oil leakage from engine components.
2. Remove oil filler cap and drain plug.
3. Drain oil and refill with new engine oil.

Oil capacity (Approximately):

Unit: liter (US qt, Imp qt)

	2WD	4WD
With oil filter change	3.8 (4, 3-3/8)	4.3 (4-1/2, 3-3/4)
Without oil filter change	3.3 (3-1/2, 2-7/8)	3.8 (4, 3-3/8)

CAUTION:

- Be sure to clean drain plug and install with new washer.
 : Drain plug
 29 - 39 N·m
 (3.0 - 4.0 kg-m, 22 - 29 ft-lb)
- Use recommended engine oil.
 Refer to GI Section.

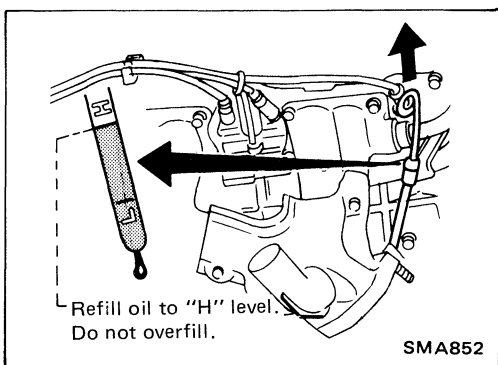

4. Check oil level.
5. Start engine. Check area around drain plug and oil filter for any sign of oil leakage.
6. Run engine for a few minutes, then turn it off. After several minutes, check oil level.

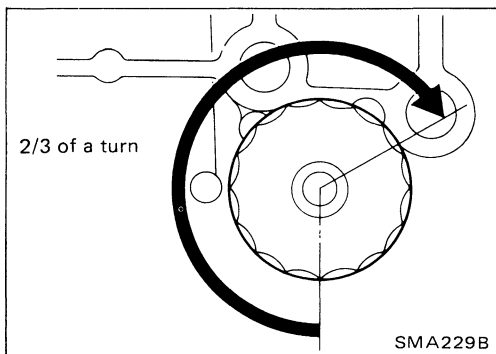
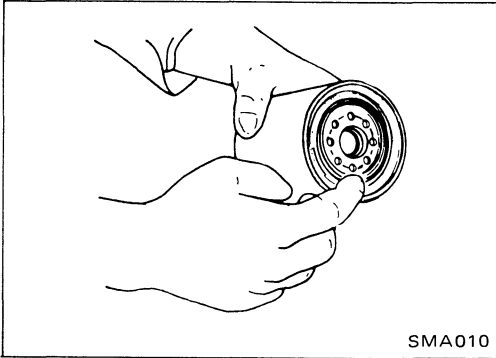
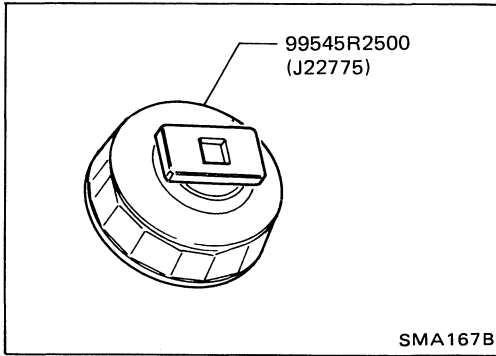

Oil Filter Replacement

1. Remove oil filter with Tool.

WARNING:

Be careful not to burn yourself, as engine and engine oil are hot.

2. Before installing new oil filter, wipe clean oil filter mounting surface on cylinder block, and smear a little engine oil on rubber seal of oil filter.

3. Screw oil filter on until a slight resistance is felt, then tighten an additional more than 2/3 turn.

4. Add engine oil.

Refer to Changing Engine Oil.

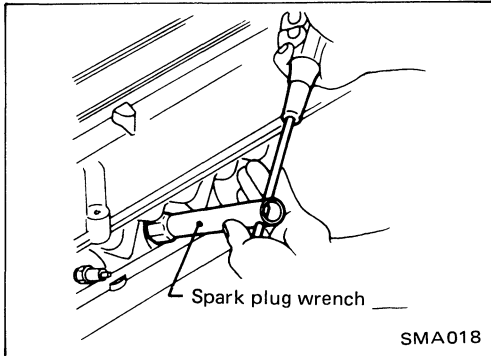
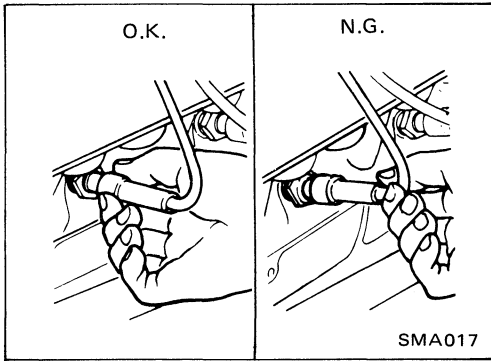



Spark Plug Replacement

1. Remove air cleaner.
2. Disconnect ignition wires from spark plugs by pulling on boots. Do not pull on wires.
3. Remove spark plugs with spark plug wrench.

SPARK PLUG:

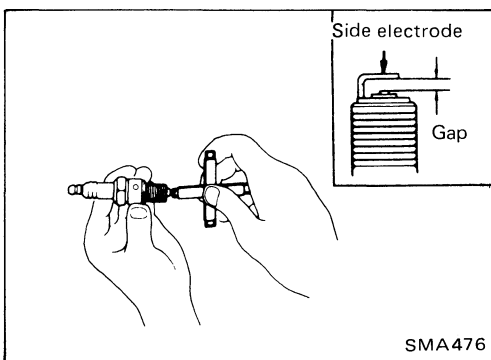
	Intake and Exhaust sides
Standard type	BPR5ES
Hot type	BPR4ES
Cold type	BPR6ES



4. Check new spark plug gap.
Gap: 0.8 - 0.9 mm (0.031 - 0.035 in)
5. Install spark plugs. Reconnect ignition wires according to Nos. indicated on them.
 : Spark plug
20 - 29 N·m
(2.0 - 3.0 kg-m, 14 - 22 ft-lb)

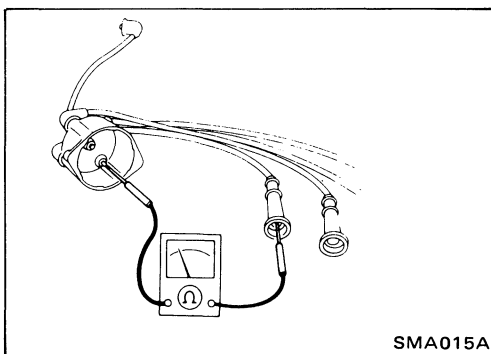

Ignition Wire (High Tension Wire) Inspection

1. Inspect ignition wires for cracks, damage, burned terminals and proper fit.
2. Measure the resistance of ignition wires by shaking them and checking for intermittent breaks.
Resistance: Less than 30 kΩ
 If N.G., replace with new one.

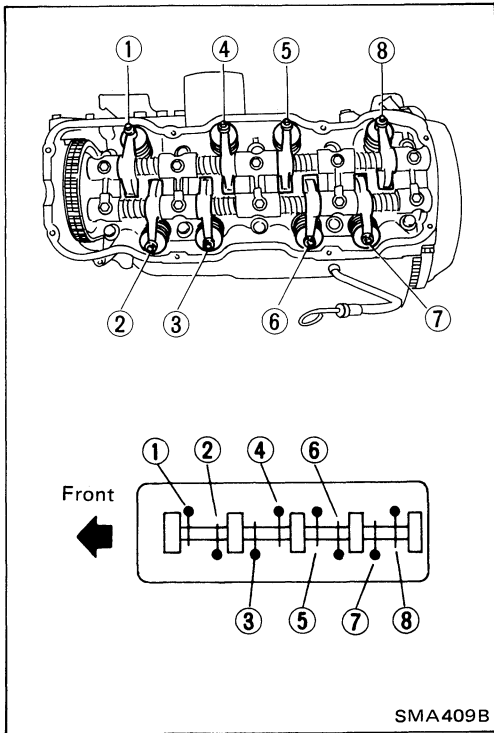

Intake and Exhaust Valve Clearance Adjustment

Adjustment must be made while engine is warm but not running.

1. Set No. 1 cylinder in top dead center on its compression stroke, and adjust valve clearance ①, ②, ④ and ⑥.
2. Set No. 4 cylinder in top dead center on its compression stroke, and adjust valve clearance ③, ⑤, ⑦ and ⑧.

Valve clearance:

Intake ①, ④, ⑤ and ⑧

0.30 mm (0.012 in)

Exhaust ②, ③, ⑥ and ⑦

0.30 mm (0.012 in)

Pivot lock nut:

 : 16 - 22 N·m (1.6 - 2.2 kg·m, 12 - 16 ft·lb)

SMA409B

Idle Speed Inspection

CAUTION:

Do not attempt to screw the idle adjusting screw down completely. Doing so could cause damage to tip, which in turn will tend to cause malfunctions.

Preparation

1. Set shift lever in "Neutral" position (in "N" or "P" position for the automatic transmission).
Engage parking brake and lock both front and rear wheels with wheel chocks.
2. Turn off air conditioner and headlamps.
3. Keep front wheels straight ahead.

WARNING:

Depress brake pedal while racing the engine to prevent forward surge of vehicle.

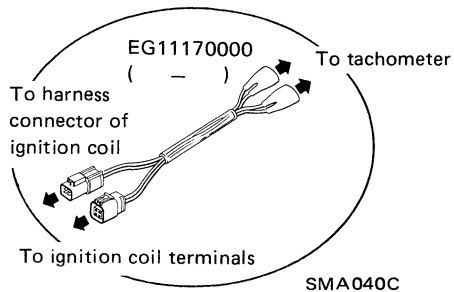

PREPARATION:

- Warm up engine until water temperature indicator points to the middle of gauge.
- Attach Tool (adapter harness) between ignition coil primary winding terminals and harness connector. Then connect tachometer to adapter harness.

Start engine.

Run engine at about 2,000 rpm for about 2 minutes under no-load.

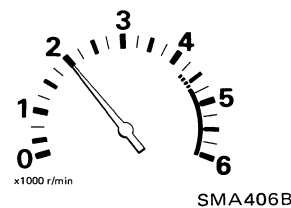

Race engine (2,000 - 3,000 rpm) two or three times under no-load, then run engine for one minute at idle speed.

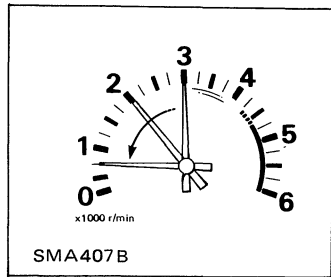

Make sure to engage parking brake and move A/T shift lever to "D" position. Check idle speed.

IDLE SPEED:
 M/T: 800±50 rpm
 A/T: 650±50 rpm
 (in "D" position)

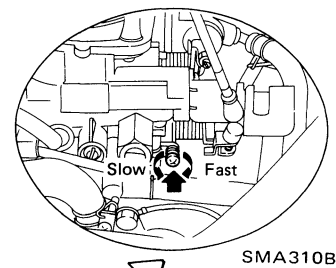

O.K.
 END

N.G.
 Adjust idle speed by turning idle speed adjusting screw.

- Disconnect adapter harness connector and connect ignition coil harness connector to ignition coil.
- After inspection and adjustment have been made, move the A/T shift lever to "N" or "P" position.

CHASSIS AND BODY MAINTENANCE

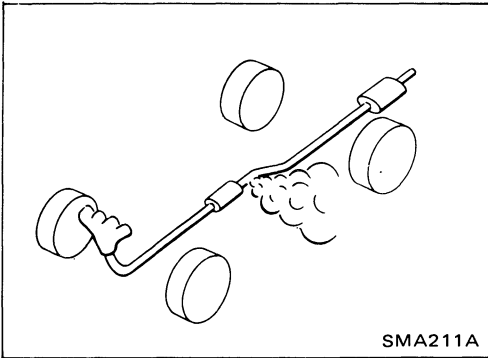

Checking Exhaust System

Check exhaust pipes, muffler and mounting for proper attachment, leaks, cracks, damage, loose connections, chafing and deterioration.

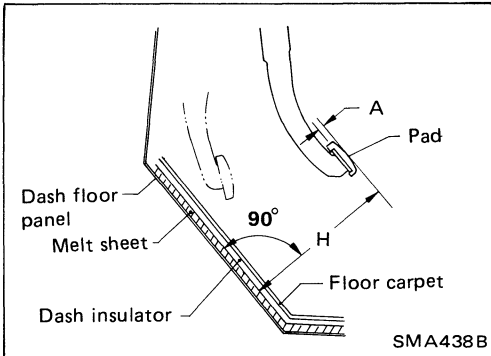

Checking Clutch Pedal Operation

Check clutch pedal height, free play and smooth operation.

Pedal height "H":

Z-engines

236 - 246 mm (9.29 - 9.69 in)

VG-engines

227 - 237 mm (8.94 - 9.33 in)

Pedal free play "A":

1 - 1.5 mm (0.039 - 0.059 in)

If necessary, adjust clutch pedal height and pedal free play. Refer to Section CL.

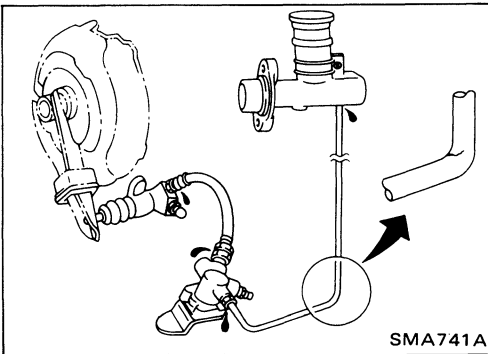

Checking Clutch System

If fluid level is extremely low, check clutch system for leaks.

CHASSIS AND BODY MAINTENANCE

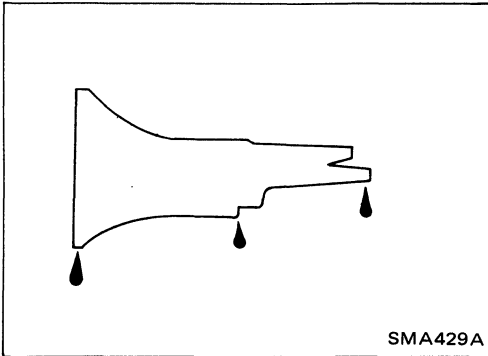

Checking M/T Oil

1. Check manual transmission for oil leakage.

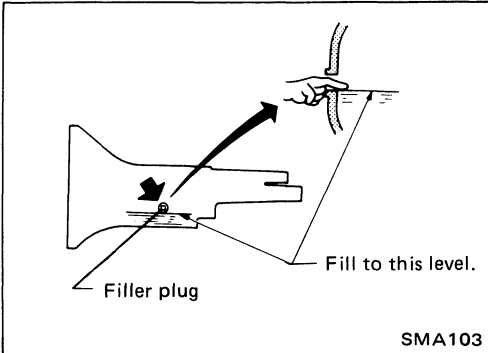

2. If leakage is found, check oil level.

-  : Filler plug
25 - 34 N·m
(2.5 - 3.5 kg-m, 18 - 25 ft-lb)

CAUTION:

Never start engine while checking oil level.

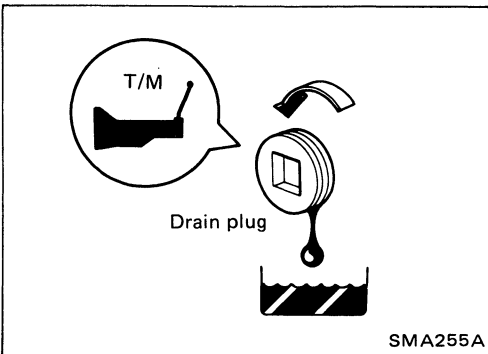

Changing M/T Oil

Oil capacity:

F4W71C 1.7 liters (3-5/8 US pt, 3 Imp pt)

FS5W71C

2WD 2.0 liters (4-1/4 US pt, 3-1/2 Imp pt)

4WD 4.0 liters (8-1/2 US pt, 7 Imp pt)

FS5R30A

2WD 2.4 liters (5-1/8 US pt, 4-1/4 Imp pt)

4WD 3.6 liters (7-5/8 US pt, 6-3/8 Imp pt)

Drain plug:

-  : 25 - 34 N·m (2.5 - 3.5 kg-m, 18 - 25 ft-lb)

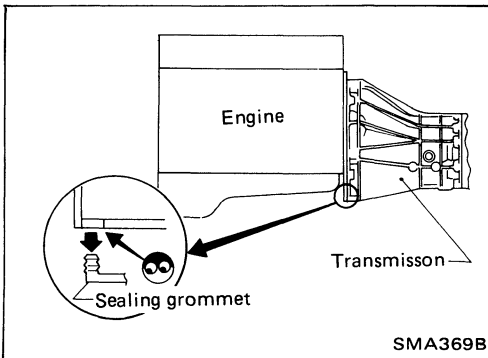

Checking Water Entry – For 4WD model

Check water entry in the clutch housing by removing the sealing grommet, whenever driving in deep water or mud.

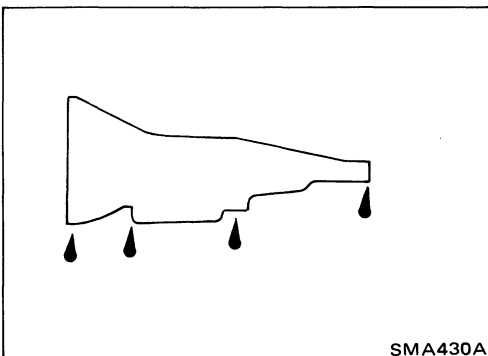

Checking A/T Fluid

1. Check automatic transmission for fluid leakage.

CHASSIS AND BODY MAINTENANCE

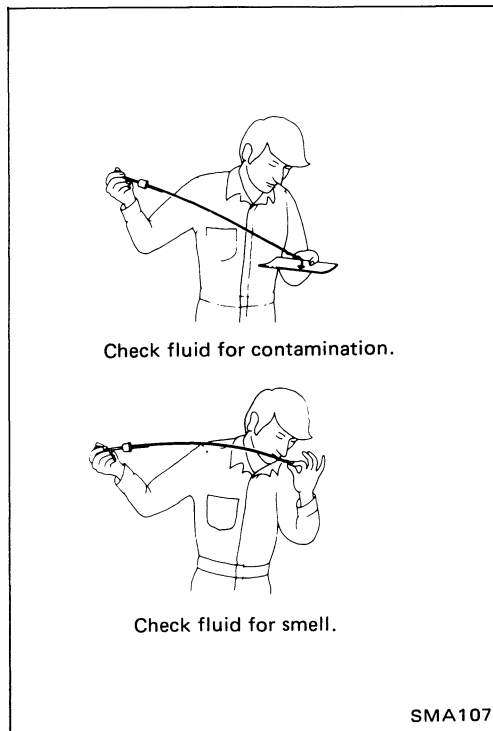
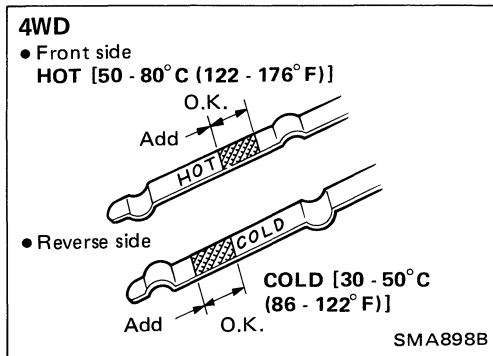
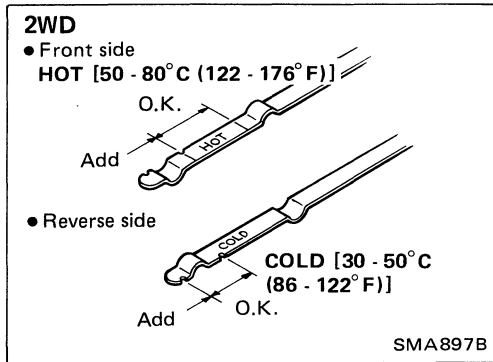

Checking A/T Fluid (Cont'd)

2. If leakage is found, check fluid level.

Fluid level should be checked using "HOT" range on dipstick at fluid temperatures of 50 to 80°C (122 to 176°F) after vehicle has been driven approximately 5 minutes in urban areas after engine is warmed up. But it can be checked at fluid temperatures of 30 to 50°C (86 to 122°F) using "COLD" range on dipstick for reference after engine is warmed up and before driving. However, fluid level must be rechecked using "HOT" range.

- (1) Park vehicle on level surface and set parking brake.
- (2) Start engine and then move selector lever through each gear range, ending in "P".
- (3) Check fluid level with engine idling.
- (4) Remove dipstick and wipe it clean with lint-free paper.
- (5) Reinsert dipstick into charging pipe as far as it will go.
- (6) Remove dipstick and note reading. If level is at low side of either range, add fluid to the charging pipe.

Do not overfill.

3. Check automatic fluid condition.

Check fluid for contamination. If fluid is very dark or smells burned, or contains the frictional material (clutches, band, etc.), check operation of A/T.

Refer to section AT for checking operation of A/T.

Changing A/T Fluid

1. Drain fluid by removing oil pan.
2. Replace gasket with new one.
3. Refill with fluid and then check fluid level.

Oil capacity (With torque converter):

L4N71B and E4N71B

7.0 liters (7-3/8 US qt, 6-1/8 Imp qt)

RE4R01A

8.5 liters (9 US qt, 7-1/2 Imp qt)

Checking Transfer Oil

1. Check transfer for oil leakage.

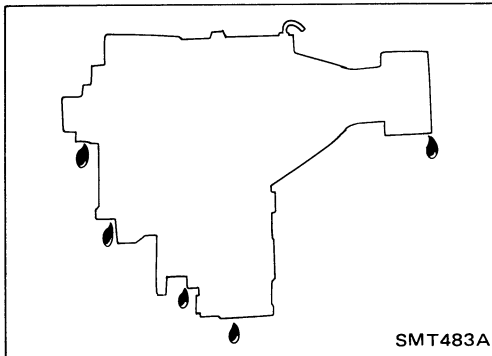

2. If leakage is found, check oil level.
Never start engine while checking oil level.

Filler plug:

 : 25 - 34 N·m (2.5 - 3.5 kg-m, 18 - 25 ft-lb)

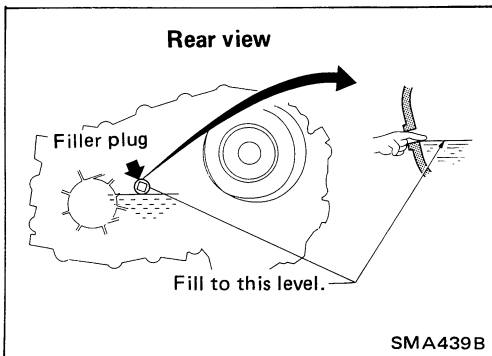

Changing Transfer Oil

Oil capacity:

2.2 liters (2-3/8 US qt, 2 Imp qt)

Drain plug:

 : 25 - 34 N·m (2.5 - 3.5 kg-m, 18 - 25 ft-lb)

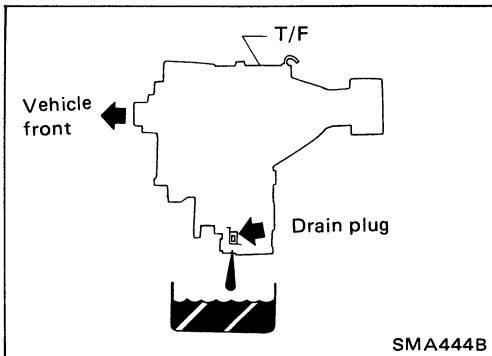

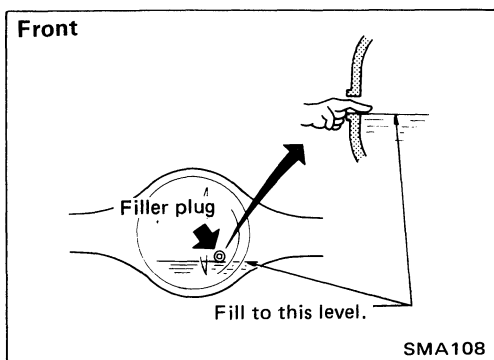
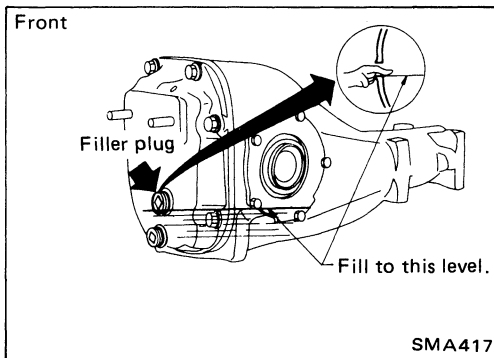
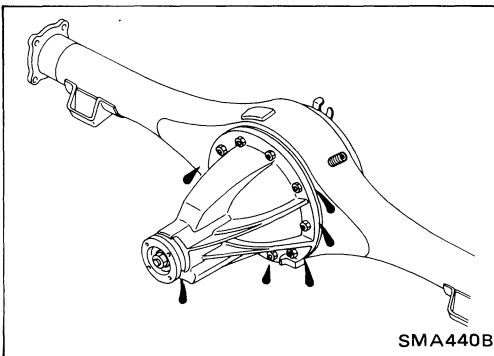
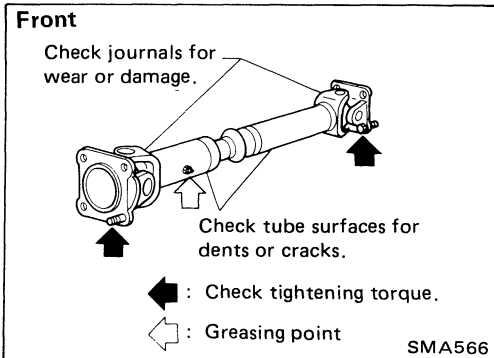
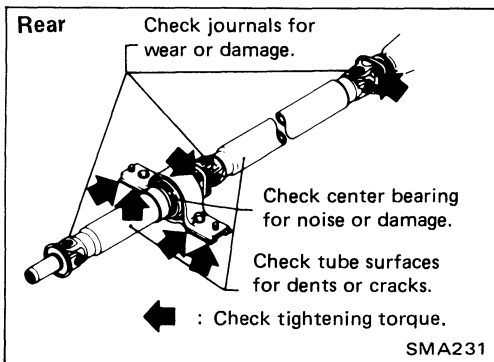

Checking Propeller Shaft

Check propeller shaft for damage, looseness or grease leakage.

Tightening torque: Refer to section PD.

Checking Differential Gear Oil

1. Check differential carrier for oil leakage.

2. If leakage is found, check oil level.

Filler plug:

Front

☑ : 39 - 59 N·m (4 - 6 kg·m, 29 - 43 ft·lb)

Rear

H190A, H233B

☑ : 59 - 98 N·m
(6 - 10 kg·m, 43 - 72 ft·lb)

C200

☑ : 39 - 59 N·m (4 - 6 kg·m, 29 - 43 ft·lb)

CHASSIS AND BODY MAINTENANCE

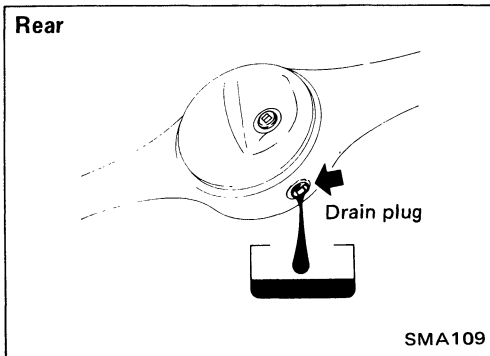
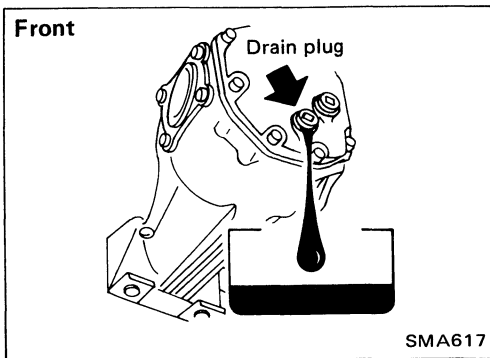

Changing Differential Gear Oil

Oil capacity:

Front

R180A

1.3 liters (2-3/4 US pt, 2-1/4 Imp pt)

R200A

1.5 liters (3-1/8 US pt, 2-5/8 Imp pt)

Drain plug:

 : 39 - 59 N·m (4 - 6 kg·m, 29 - 43 ft·lb)

Oil capacity:

Rear

H190A

1.5 liters (3-1/8 US pt, 2-5/8 Imp pt)

C200

1.3 liters (2-3/4 US pt, 2-1/4 Imp pt)

H233B

2.8 liters (5-7/8 US pt, 4-7/8 Imp pt)

Drain plug:

 : 59 - 98 N·m (6 - 10 kg·m, 43 - 72 ft·lb)

Limited-slip differential gear

- Use only approved limited-slip differential gear oil.
 - Limited-slip differential identification.
- (1) Lift both rear wheels off the ground.
 - (2) Turn one rear wheel by hand.
 - (3) If both rear wheels turn in the same direction simultaneously, vehicle is equipped with limited-slip differential.

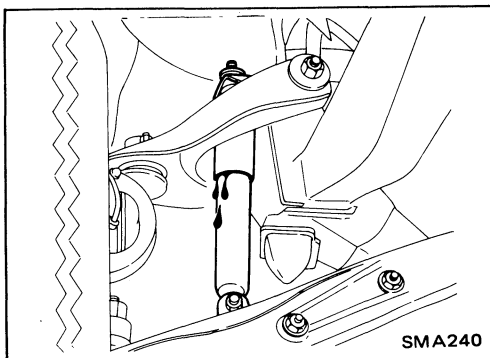
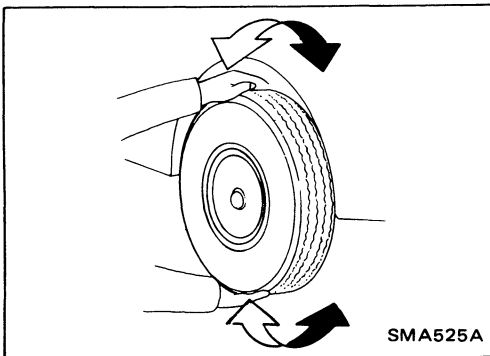

Checking Front Axle and Front Suspension Parts

- Check front axle and front suspension parts for looseness, cracks, wear or other damage.
- (1) Shake each front wheel.
 - (2) Make sure that cotter pin is inserted.
 - (3) Retighten all nuts and bolts to the specified torque.
Tightening torque: Refer to section FA.
 - (4) Check front axle and front suspension parts for wear, cracks or other damage.
- Check shock absorber for oil leakage or other damage.

CHASSIS AND BODY MAINTENANCE

Checking Front Axle and Front Suspension Parts (Cont'd)

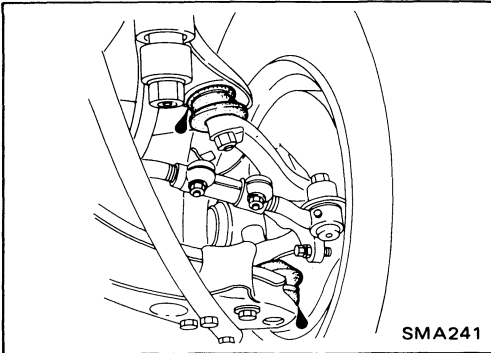

- Check suspension ball joint for grease leakage and ball joint dust cover for cracks or other damage.

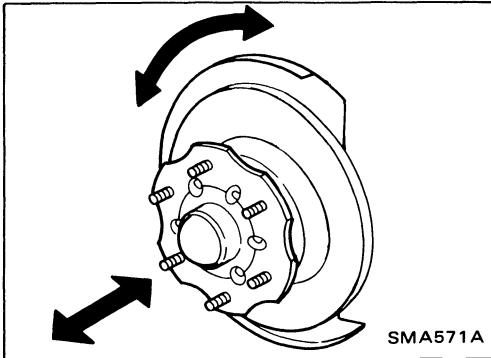

Checking (Replacing) Front Wheel Bearing Grease

- Check that wheel bearings operate smoothly.
- Check front wheel bearings for grease leakage and water or dust entry.
- Replace front wheel bearings or front wheel bearing grease if wheel bearings do not turn smoothly.
- Adjust wheel bearing preload after installing wheel bearings or replacing wheel bearing grease.

PRELOAD ADJUSTMENT (2WD)

Adjust wheel bearing preload as follows:

1. Before adjustment, thoroughly clean all parts and check them for wear, cracks or other damage.

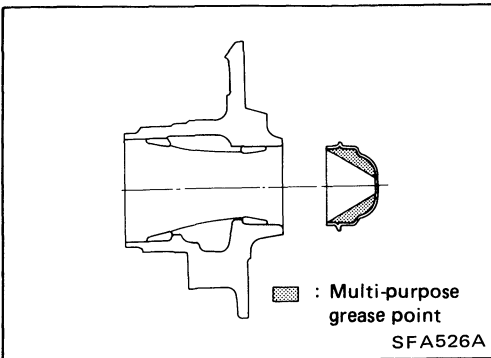

2. Apply multi-purpose grease sparingly to the following parts:

- Rubbing surface of spindle
- Contact surface between lock washer and outer wheel bearing
- Hub cap (as shown at the left)
- Grease seal lip

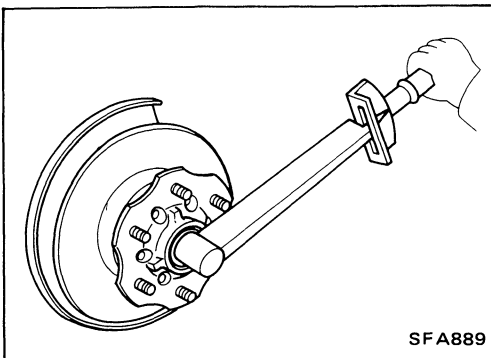

3. Tighten wheel bearing lock nut to the specified torque.

 : 34 - 39 N·m (3.5 - 4.0 kg·m, 25 - 29 ft·lb)

CHASSIS AND BODY MAINTENANCE

Checking (Replacing) Front Wheel Bearing Grease (Cont'd)

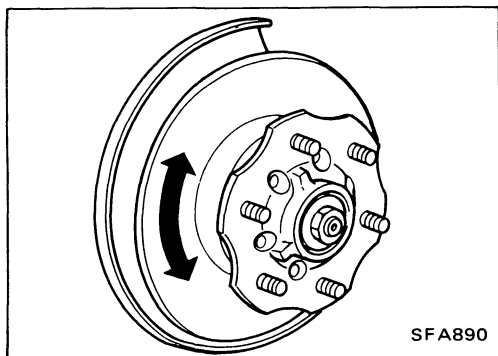

4. Turn wheel hub several times in both directions to seat wheel bearing correctly.
5. Again tighten wheel bearing lock nut to the specified torque.
☑ : 34 - 39 N·m (3.5 - 4.0 kg·m, 25 - 29 ft·lb)

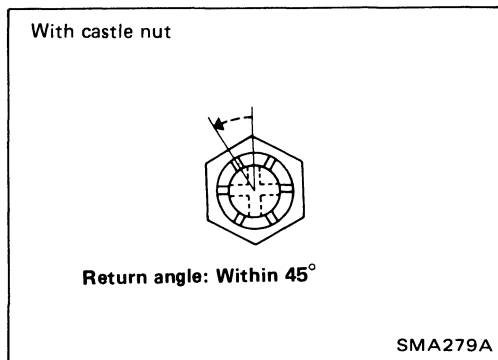

6. Turn back wheel bearing lock nut 45 degrees.

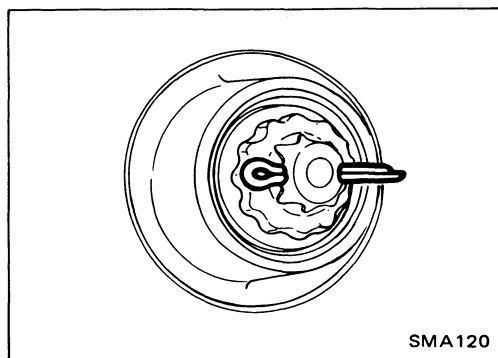

7. Fit adjusting cap and new cotter pin. Align cotter pin slot by loosening nut 15 degrees or less.

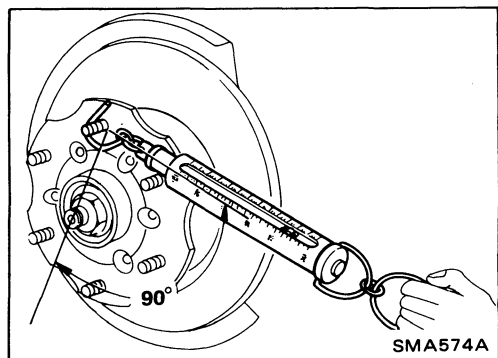

8. Measure wheel bearing preload and axial end play.
Axial end play: 0 mm (0 in)
Wheel bearing preload
(As measured at wheel hub bolt):
[New grease seal]
9.8 - 28.4 N (1.0 - 2.9 kg, 2.2 - 6.4 lb)
[Used grease seal]
9.8 - 23.5 N (1.0 - 2.4 kg, 2.2 - 5.3 lb)

Repeat above procedures until correct bearing preload is obtained.

9. Spread cotter pin.
10. Install hub cap.

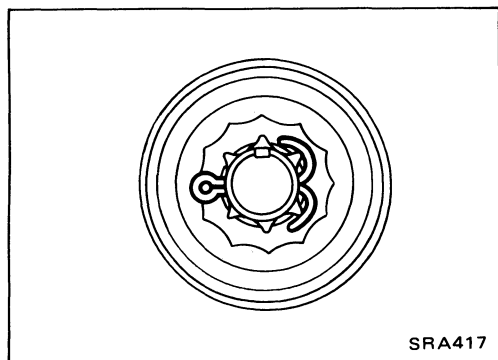

CHASSIS AND BODY MAINTENANCE

Checking (Replacing) Front Wheel Bearing Grease (Cont'd)

PRELOAD ADJUSTMENT (4WD)

Adjust wheel bearing preload as follows:

1. Before adjustment, thoroughly clean all parts and check them for wear, cracks or other damage.

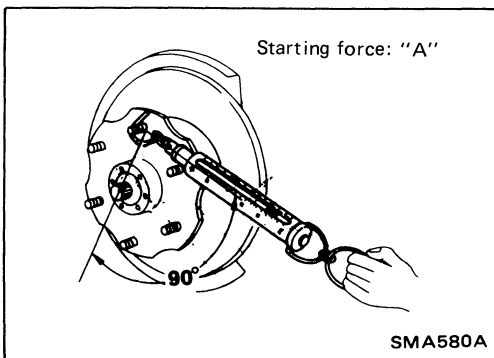
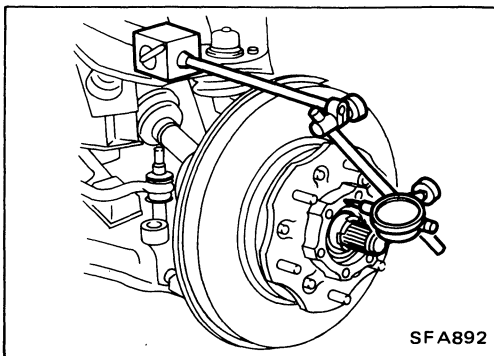
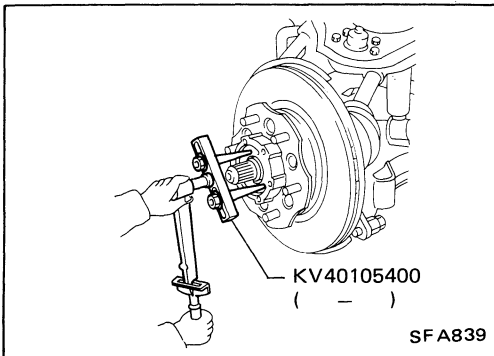
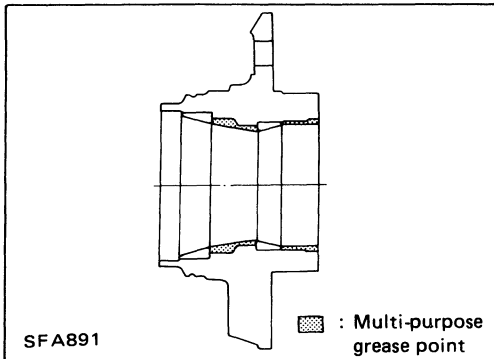

2. Apply multi-purpose grease sparingly to the following parts:

- Threaded portion of spindle
- Contact surface between wheel bearing washer and outer wheel bearing
- Grease seal lip
- Wheel hub (as shown at the left)

3. Tighten wheel bearing lock nut with Tool.

 : 78 - 98 N·m
(8 - 10 kg-m, 58 - 72 ft-lb)

4. Turn wheel hub several times in both directions.

5. Loosen wheel bearing lock nut so that torque becomes 0 N·m (0 kg-m, 0 ft-lb).

6. Retighten wheel bearing lock nut with Tool.

 : 0.5 - 1.5 N·m
(0.05 - 0.15 kg-m, 0.4 - 1.1 ft-lb)

7. Turn wheel hub several times in both directions.

8. Retighten wheel bearing lock nut with Tool.

 : 0.5 - 1.5 N·m
(0.05 - 0.15 kg-m, 0.4 - 1.1 ft-lb)

9. Measure wheel bearing axial end play.

Axial end play: 0 mm (0 in)

10. Measure starting force "A" at wheel hub bolt.

CHASSIS AND BODY MAINTENANCE

Checking (Replacing) Front Wheel Bearing Grease (Cont'd)

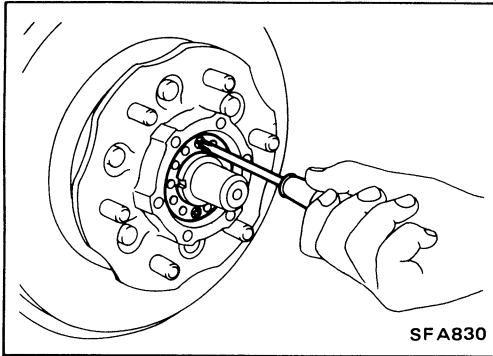

11. Install lock washer by tightening the lock nut within 15 to 30 degrees.
12. Turn wheel hub several times in both directions to seat wheel bearing correctly.
13. Measure starting force "B" at wheel hub bolt. Refer to procedure 10.
14. Wheel bearing preload "C" can be calculated as shown below:

$$C = B - A$$

Wheel bearing preload "C":

7.06 - 20.99 N

(0.72 - 2.14 kg, 1.59 - 4.72 lb)

15. Repeat above procedures until correct axial end play and wheel bearing preload are obtained.
16. Install free-running hub and brake pads.

Checking Front Wheel Alignment

Before checking front wheel alignment, be sure to make a preliminary inspection.

PRELIMINARY INSPECTION

1. Check tires for wear and proper inflation.

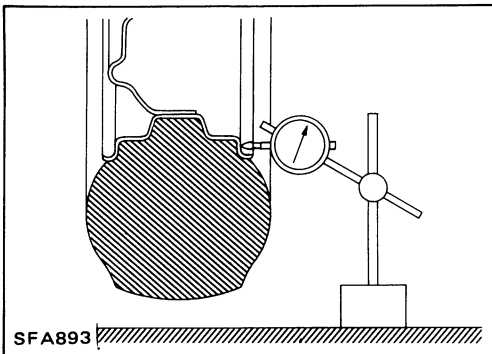

2. Check wheel runout.

Lateral runout:

Refer to Wheel Inspection in section MA.

3. Check front wheel bearings for looseness.
4. Check front suspension for looseness.
5. Check steering linkage for looseness.
6. Check that front shock absorbers work properly by using the standard bounce test.

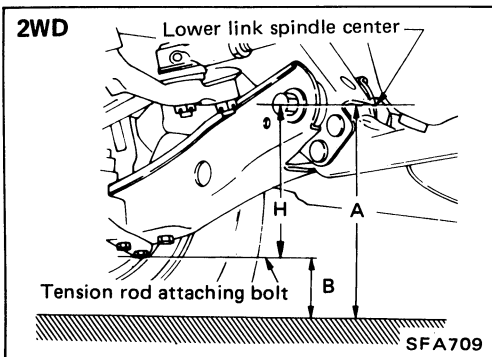

7. Measure vehicle height (Unladen): $H = A - B$ mm (in)

Vehicle height:

Refer to S.D.S.

- 1) Exercise the front suspension by bouncing the front of the vehicle 4 or 5 times to ensure that the vehicle is in a neutral height attitude.
- 2) Measure wheel alignment.
(Refer to **B** SERVICE CHECKING on S.D.S.)
- 3) If wheel alignment is not as specified, adjust vehicle posture.
(Refer to **A** SERVICE SETTING on S.D.S.)

CHASSIS AND BODY MAINTENANCE

Checking Front Wheel Alignment (Cont'd)

4) Adjust wheel alignment.

(Refer to **B** SERVICE SETTING on S.D.S.)

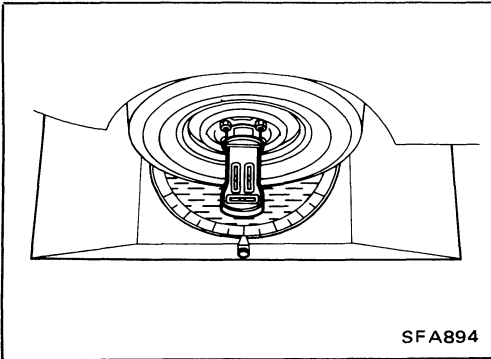
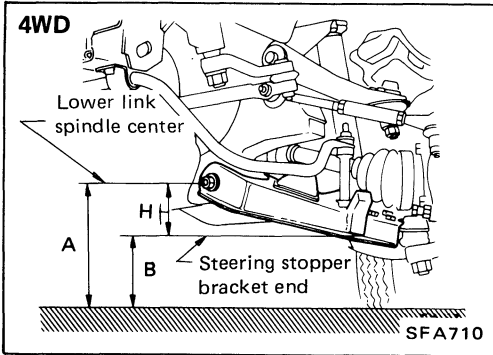

CAMBER, CASTER AND KINGPIN INCLINATION

Before checking camber, caster or kingpin inclination, move vehicle up and down on turning radius gauge to minimize friction.

- Measure camber, caster and kingpin inclination of both right and left wheels with a suitable alignment gauge and adjust in accordance with the following procedures.

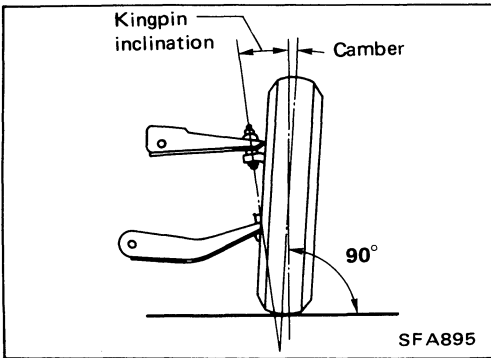

Camber and kingpin inclination

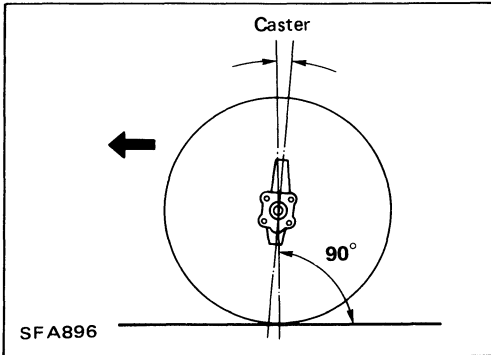

Caster

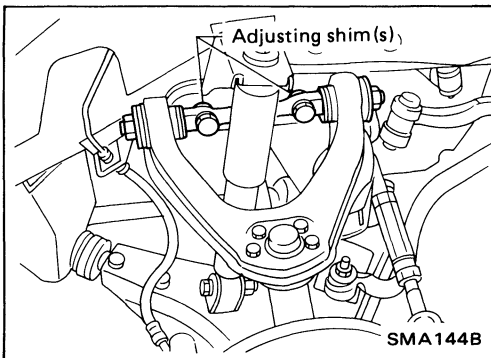

ADJUSTMENT

Both camber and caster angles are adjusted by increasing or decreasing the number of adjusting shims inserted between upper link spindle and frame.

CHASSIS AND BODY MAINTENANCE

Checking Front Wheel Alignment (Cont'd)

Before removing or installing adjusting shim(s), be sure to place a jack under lower link.

Adjusting shim standard thickness:

2WD	2.9 mm (0.114 in)
4WD	4.0 mm (0.157 in)

- Do not use three or more shims at one place.
- When installing shim B, always face the pawl towards spindle and insert them from bracket side. Use only one shim in a place.
- Total thickness of shims must be within 8.0 mm (0.315 in).

Camber

To adjust camber, equalize thickness of front and rear shims by adding or removing shim(s).

Camber (Unladen): Refer to S.D.S.

- When adding 1.0 mm (0.039 in) shim to each of the front and rear.

Camber increases

2WD	12'
4WD	14'

Caster

To adjust caster, make a difference in thickness between front and rear shims.

Caster (Unladen): Refer to S.D.S.

- When front shim(s) is 1.0 mm (0.039 in) thicker than rear one(s),

	2WD	4WD
Caster increases	19'	26'
Camber increases	6'	6'

- When rear shim(s) is 1.0 mm (0.039 in) thicker than front one(s),

	2WD	4WD
Caster decreases	19'	20'
Camber increases	6'	8'

- Difference of total thickness of the front and rear must be within 2.0 mm (0.079 in).
- When caster is adjusted, camber angle changes and camber needs to be measured again. If necessary, adjust camber.

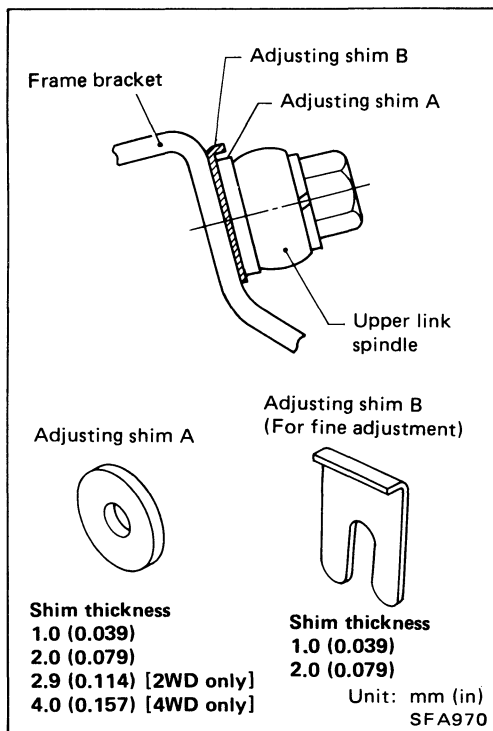

CHASSIS AND BODY MAINTENANCE

Checking Front Wheel Alignment (Cont'd)

TOE-IN

1. Mark a base line across the tread.
After lowering front of vehicle, move it up and down to eliminate friction, and set steering wheel in straight ahead position.

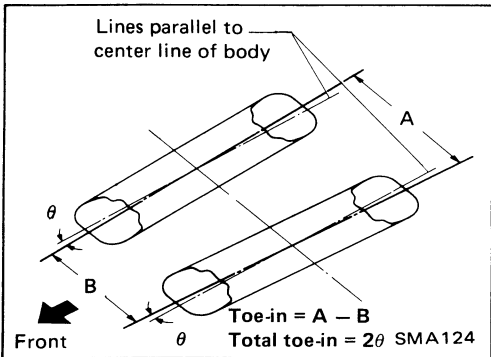
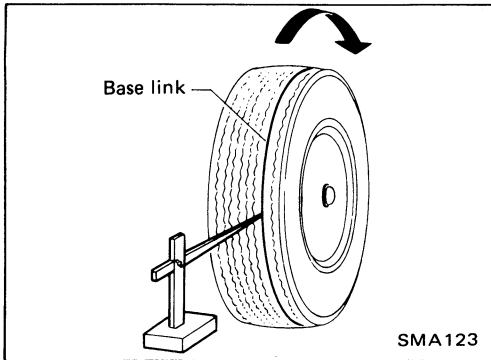

2. Measure toe-in.

Measure distance "A" and "B" at the same height as hub center.

Toe-in (Unladen): Refer to S.D.S.

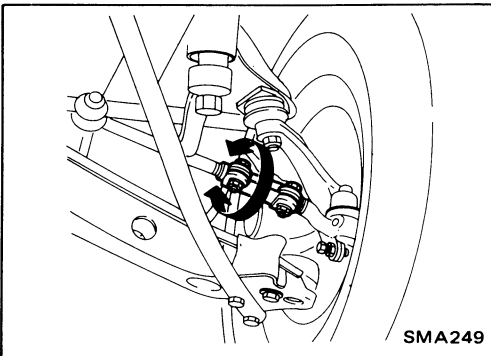

3. Adjust toe-in by varying the length of steering tie-rod.

- (1) Loosen clamp bolts or lock nuts.
- (2) Adjust toe-in by turning the left and right tie-rod tubes an equal amount.

Make sure that the tie-rod bars are screwed into the tie-rod tube more than 35 mm (1.38 in).

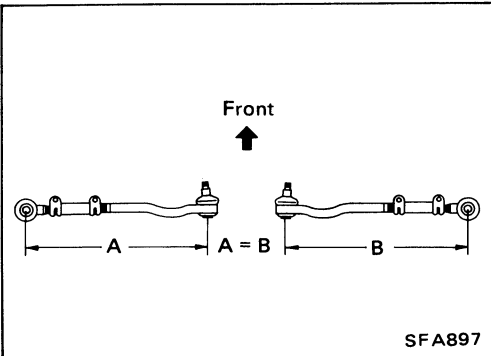

Make sure that the tie-rod bars are the same length.

Standard length $A = B$

2WD: 344 mm (13.54 in)

4WD: 281 mm (11.06 in)

(3) Tighten clamp bolts or lock nuts.

Clamp bolts (2WD)

 : 14 - 20 N-m (1.4 - 2.0 kg-m, 10 - 14 ft-lb)

Lock nuts (4WD)

 : 78 - 98 N-m (8.0 - 10.0 kg-m, 58 - 72 ft-lb)

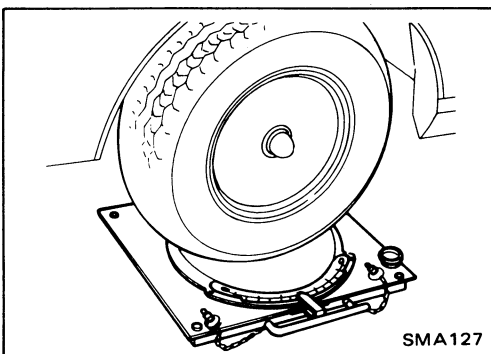

WHEEL TURNING ANGLE

1. Set wheels in straight ahead position and then move vehicle forward until front wheels rest on turning radius gauge properly.

CHASSIS AND BODY MAINTENANCE

Checking Front Wheel Alignment (Cont'd)

- Rotate steering wheel all the way right and left; measure turning angle.

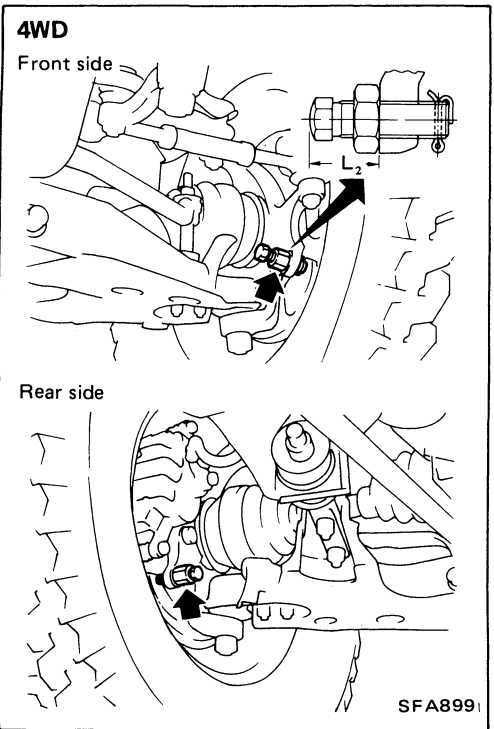
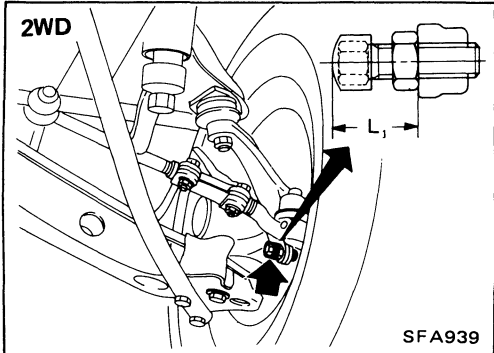
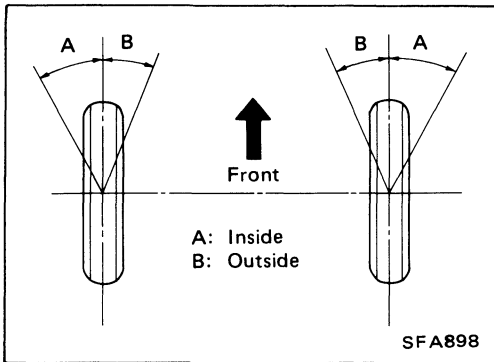

Wheel turning angle		2WD	4WD	
			31x10.5R15*	
Full turns	Inside wheel	36° - 38°	33° - 35°	27° - 29°
	Outside wheel	33° - 35°	31° - 33°	25° - 27°
Toe-out turn (at 20°)	Inside wheel	22°		
	Outside wheel	20°		

*: Tire size

- Adjust by stopper bolt if necessary.

[2WD]

Standard length "L₁":
20 mm (0.79 in)

[4WD]

Standard length "L₂":
26.5 mm (1.043 in) [Except tire size 31x10.5R15]
37.5 mm (1.476 in) [Tire size 31X10.5R15]

Checking Free-running Hub Grease

- Check free-running hub for grease leakage and water or dust entry.
- When installing free-running hub, use multi-purpose grease for manual-lock free-running hub and NISSAN GENUINE GREASE (KRC19-00025) or equivalent grease for auto-lock free-running hub.

Refer to Section FA.

CHASSIS AND BODY MAINTENANCE

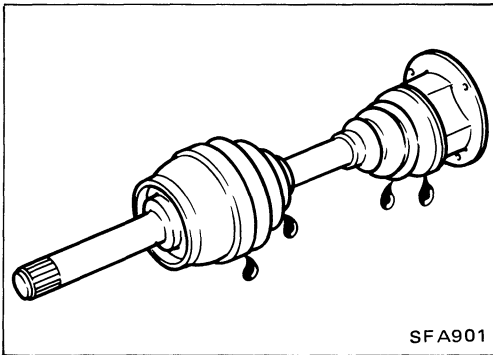

Checking Drive Shaft

Check boot and drive shaft for cracks, wear, damage or grease leakage.

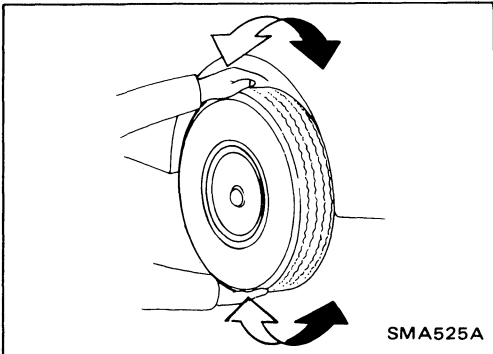

Checking Rear Axle and Rear Suspension Parts

- Check axle and suspension parts for looseness, wear or damage.

(1) Shake each rear wheel.

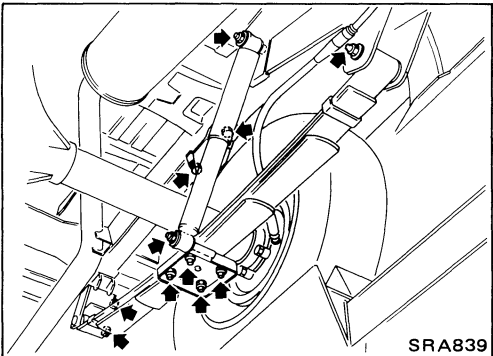

(2) Retighten all nuts and bolts to the specified torque.

Tightening torque: Refer to section RA.

(3) Check axle and suspension parts for wear, cracks or other damage.

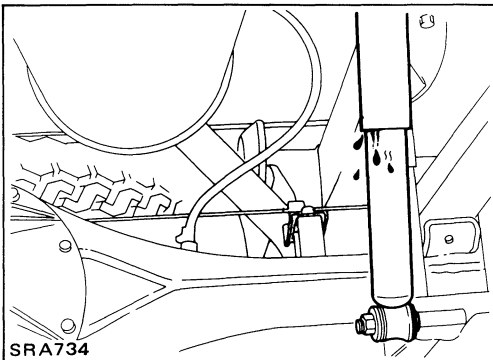

- Check shock absorber for oil leakage or damage.

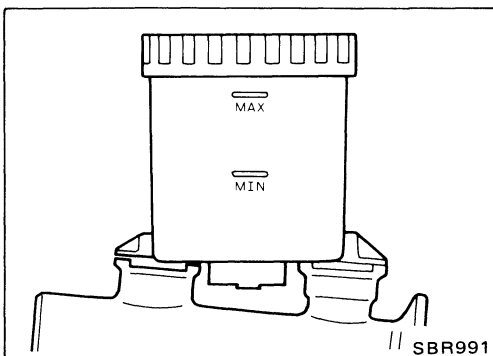

Checking Brake Fluid Level and Leaks

If fluid level is extremely low, check brake system for leaks.

CHASSIS AND BODY MAINTENANCE

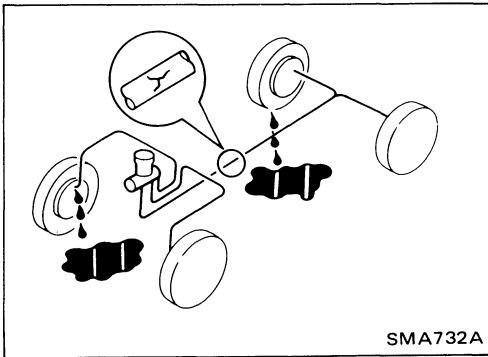

Checking Brake System

Check brake fluid lines and parking brake cables for proper attachment, leaks, chafing, abrasion, deterioration, etc.

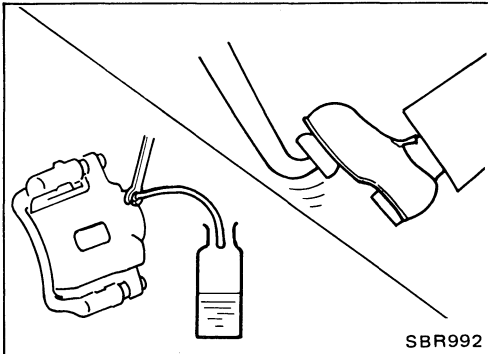

Changing Brake Fluid

1. Drain brake fluid from each air bleeder valve.
2. Refill until new brake fluid comes out from each air bleeder valve.

Use same procedure as in bleeding hydraulic system to refill brake fluid.

Refer to section BR.

- Refill with recommended brake fluid "DOT 3".
- Do not reuse drained brake fluid.
- Be careful not to splash brake fluid on painted areas.

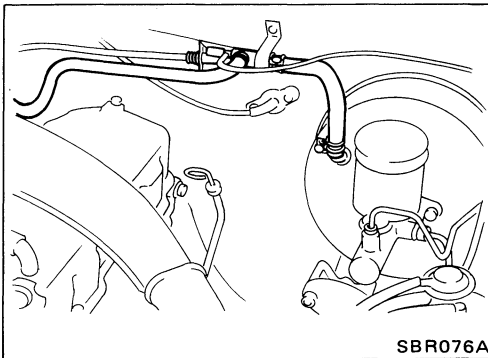

Checking Vacuum Hoses

Check vacuum lines, connections and check valve for proper attachment, air tightness, chafing and deterioration.

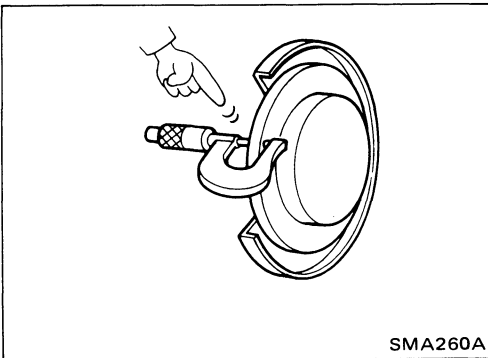

Checking Disc Brake

Check condition of disc brake components.

ROTOR

Check condition and thickness.

Minimum thickness:

CL28VA	20 mm (0.79 in)
CL28VD	24 mm (0.94 in)
AD14VB	16 mm (0.63 in)

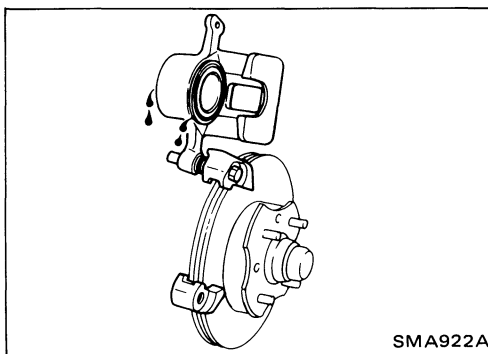

CALIPER

Check operation and leakage.

CHASSIS AND BODY MAINTENANCE

Checking Disc Brake (Cont'd)

PAD

Check wear or damage.

Minimum thickness: 2 mm (0.08 in)

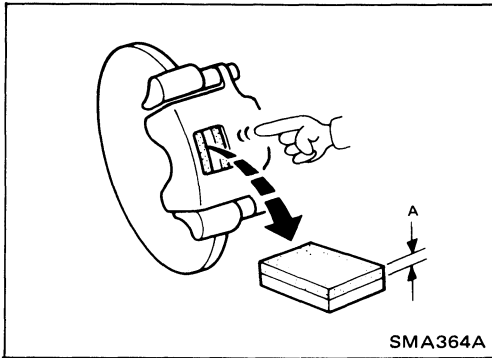

Checking Drum Brake

Check condition of drum brake components.

WHEEL CYLINDER

Check operation and leakage.

DRUM

Check condition and inner surface.

Drum repair limit (Inner diameter):

LT26B	261.5 mm (10.30 in)
DS25B, DS25C, DS25D	255.5 mm (10.06 in)
DS22	221.5 mm (8.72 in)
DS19HB	191.0 mm (7.52 in)

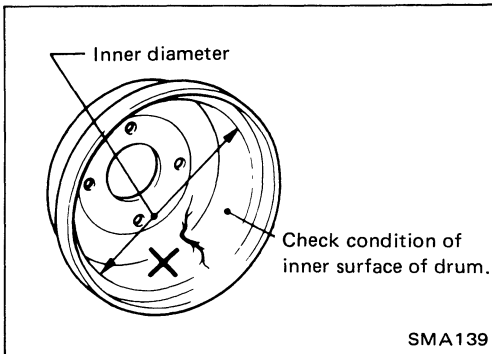

LINING

Check wear or damage.

Lining wear limit (Minimum thickness):

1.5 mm (0.059 in)

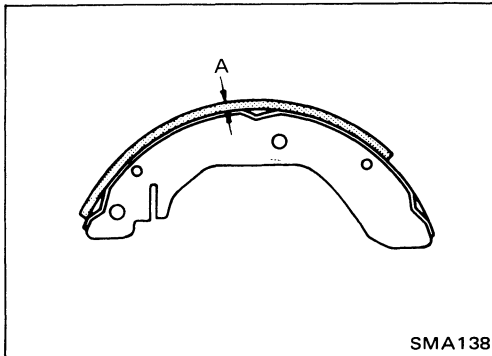

PARKING DRUM BRAKE

Adjust lining and drum as follows:

- (1) Set the transfer lever in the "2H" position. Using either low or 2nd transmission speed, drive the unloaded vehicle at approximately 30 km/h (19 MPH) on a safe, level and dry road.
- (2) Depress the release button of the parking brake lever and pull the lever back with a force of 98 N (10 kg, 22 lb).
- (3) While holding the lever back, continue to drive the vehicle 100 m (328 ft).
- (4) Repeat steps 1 through 3 two or three times.

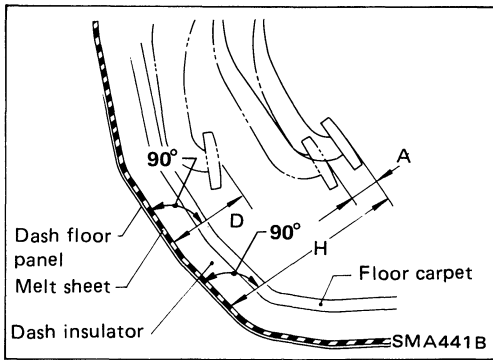

Checking Foot Brake Pedal Operation

Check brake pedal free height, depressed height and for smooth operation.

H: Free height

A/T 212 - 222 mm (8.35 - 8.74 in)

M/T 209 - 219 mm (8.23 - 8.62 in)

D: Depressed height

Under force of 490 N (50 kg, 110 lb)
with engine running

120 mm (4.72 in) or more

A: Pedal free play

1.0 - 3.0 mm (0.039 - 0.118 in)

If necessary, adjust brake pedal free height and depressed height. Refer to section BR.

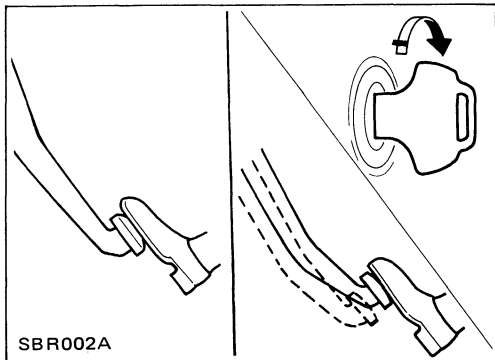

Checking Brake Booster Function

- Depress brake pedal several times with engine off, then check that there is no change in pedal stroke.
- Depress brake pedal, then start engine. If pedal goes down slightly, operation is normal.

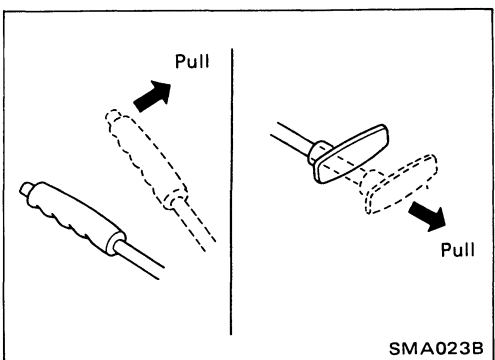

Checking Parking Brake

1. Pull lever with specified amount of force.

Check lever stroke and for smooth operation.

Number of notches [At pulling force of
196 N (20 kg, 44 lb)] :

Refer to S.D.S.

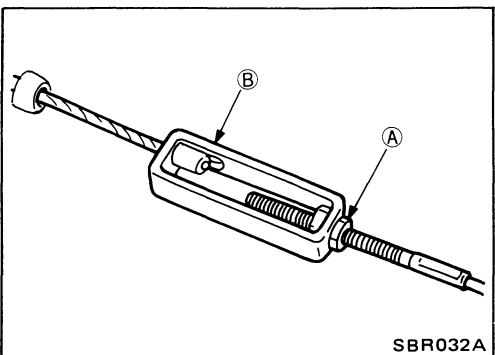

2. Use adjuster to adjust lever stroke.

(1) Loosen lock nut (A), rotate adjuster (B).

(2) Tighten lock nut (A).

CHASSIS AND BODY MAINTENANCE

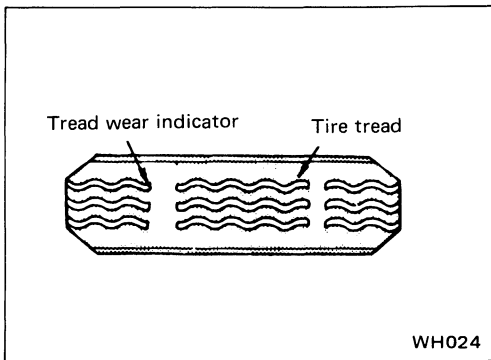

Checking Tire Condition

TIRE CONDITION

- When tread wear indicators appear, replace tire with new one.

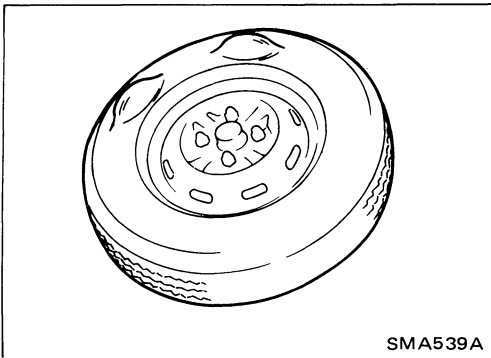

- Check tread and side walls for cracks, holes, separation or damage.
- Check tire valves for air leakage.

TIRE INFLATION

Tire pressure should be measured when tire is cold.

Tire pressure should be set to the specifications on the tire placard located into the glove box.

ABNORMAL TIRE WEAR

Correct abnormal tire wear according to the chart shown below:

Condition	Probable cause	Corrective action	Condition	Probable cause	Corrective action
<p>Shoulder wear</p>	<ul style="list-style-type: none"> • Underinflation (both sides wear) • Incorrect wheel camber (one side wear) • Hard cornering • Lack of rotation 	<ul style="list-style-type: none"> • Measure and adjust pressure. • Repair, or replace axle and suspension parts. • Reduce speed. • Rotate tires. 	<p>Feathered edge</p> <p>Toe-in or toe-out wear</p>	<ul style="list-style-type: none"> • Incorrect toe 	<ul style="list-style-type: none"> • Adjust toe-in.
<p>Center wear</p>	<ul style="list-style-type: none"> • Overinflation • Lack of rotation 	<ul style="list-style-type: none"> • Measure and adjust pressure. • Rotate tires. 	<p>Uneven wear</p>	<ul style="list-style-type: none"> • Incorrect camber or caster • Malfunctioning suspension • Unbalanced wheel • Out-of-round brake drum • Other mechanical conditions • Lack of rotation 	<ul style="list-style-type: none"> • Repair, or replace axle and suspension parts. • Repair, replace or, if necessary, reinstall. • Balance or replace. • Correct or replace. • Correct or replace. • Rotate tires.

SMA197B

Tire Replacement

CAUTION:

- Do not mix different types of tires, such as bias, bias belted and radial tires under any circumstances.
- When replacing a tire, use a tire of the same size and type (Bias, Belted or Radial).
- Use recommended tires and wheels.
- Do not mix tires of different brands, tread patterns or type.
- When replacing standard tires with those tires of an optional recommended size and of different diameter, the speedometer requires to be recalibrated.
- Install road wheel using the wheel hub boss.

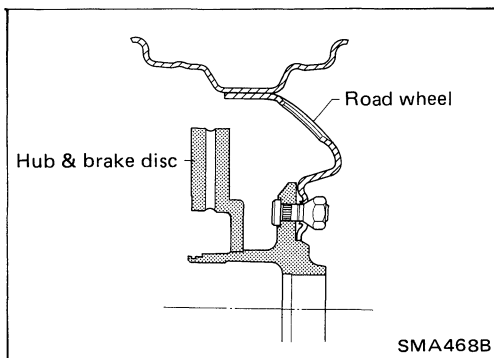
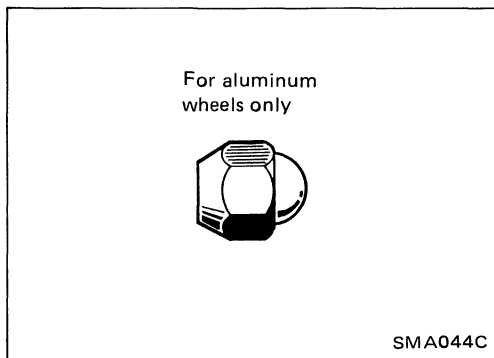

Wheel Nut

CAUTION:

- Be careful not to smear threaded portion of bolt and nut as well as seat of nut with oil or grease.
- Use tapered wheel nuts for both steel wheel.
- Tighten wheel nuts in crisscross fashion.

Be sure to check wheel nuts for tightness, after aluminum wheel has been run for the first 1,000 km (600 miles) (also in case of repairing flat tires, tire rotation, etc.). Retighten if necessary.

Tire Repair

CAUTION:

When replacing tire, take extra care not to damage tire bead, rim-flange and bead seat.

When installing tire, note the following items:

- a. Install valve core and inflate to proper pressure. Check the locating rings of the tire to be sure they show around the rim flanges on both sides.
- b. Check valves for leakage after inflating tires.
- c. Be sure to tighten valve caps firmly by hand.

WARNING:

To avoid serious personal injury, never stand over tire when inflating it. Never inflate to a pressure greater than 40 psi (275 kPa). If beads fail to seat at that pressure, deflate the tire, lubricate it again, and then reinflate it. If the tire is overinflated, the bead might break, possibly resulting in serious personal injury.

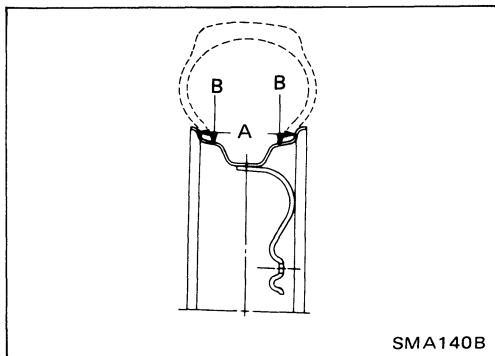

Wheel Inspection

- Check wheel rim (especially rim flange and bead seat) for rust, distortion, cracks or other damage.
- Examine wheel rim for lateral and radial runout with dial gauge.

Average value of right and left radial runout (B):

Lateral runout (A) and radial runout (B):

Difference between right and left radial runout:

Refer to S.D.S.

- Replace wheel when any of the following conditions occur.
 - a. Bent, dented or heavily rusted
 - b. Elongated bolt holes
 - c. Excessive lateral or radial runout
 - d. Air leaks through welds
 - e. Wheel nuts will not stay tight

CHASSIS AND BODY MAINTENANCE

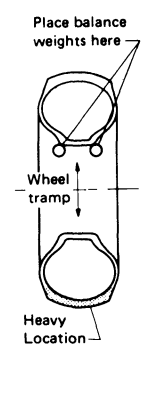
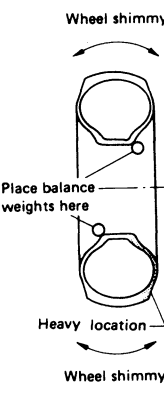
Cause	Wheel static unbalance	Wheel dynamic unbalance
Symptom of unbalance	Wheel tramp Wheel shimmy	Wheel shimmy
Corrective action	Balance statically 	Balance dynamically 

SMA075

Balancing Wheels

- Adjust wheel balance using the road wheel center.
Wheel balance (Maximum allowable unbalance at rim flange):
Refer to S.D.S.
Tire balancing weight: Refer to S.D.S.

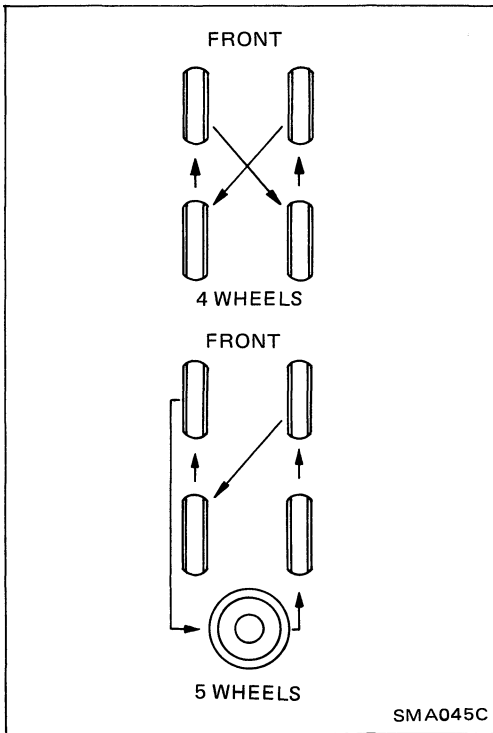

Tire Rotation

Spare Tire

T-TYPE SPARE TIRE AND SMALL SIZE SPARE TIRE

The T-type/Small size spare tire is designed for emergency use only.

The spare tire can be used repeatedly for emergency situations.

Precautions when using T-type/Small size spare tire

- Periodically check tire inflation pressure, and always keep it at 60 psi (415 kPa) [T-type spare tire].
- Periodically check tire inflation pressure, and always keep it at 26 psi (180 kPa) [Small size spare tire].
- Do not drive vehicle at speed faster than 80 km/h (50 MPH).
- The T-type/Small size spare tire is designed only for temporary use as a spare. Dismount it and keep it as a spare as soon as the standard tire repair has been completed.
- Do not attach a tire chain.
- Do not use the T-type/Small size spare tire on other cars.
- Do not make a sharp turn, or apply the brake suddenly while driving.
- As soon as the tread wear indicator becomes visible, replace the tire with a new one.
- Mounting and dismounting to and from the road wheel can be carried out in the same manner as any ordinary tire.
- Use of wheel balance is unnecessary.

CAUTION:

If the vehicle is equipped with aluminum wheels, be sure to use the wheel nuts for steel wheel on the T-type/Small size spare tire wheel. Never use the wheel nuts for aluminum wheel on the spare tire wheel.

The spare tire wheel may come off the axle and cause personal injury if the wheel nuts for aluminum wheels are used.

Checking Steering Gear and Linkage

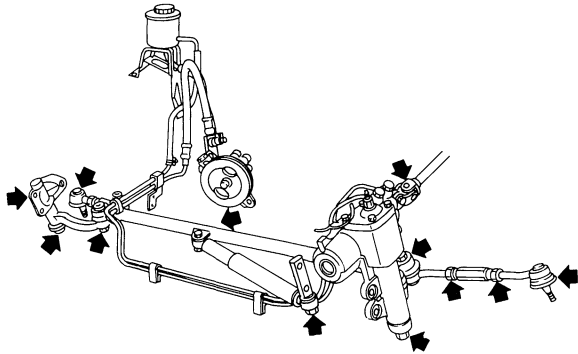

SMA442B

- Steering gear:
 - (1) Check gear housing for looseness, damage or grease leakage.
 - (2) Check connection with steering column for looseness.
- Steering linkage:
 - (1) Check ball joint, dust cover and other component parts for looseness, wear, damage or grease leakage.
 - (2) Check for missing parts (cotter pins, washer, etc.).

SMA232B

Checking Power Steering System Fluid and Lines

- Check fluid level, when the fluid is cold.
- Check lines for proper attachment, leaks, cracks, damage, loose connections, chafing and deterioration.

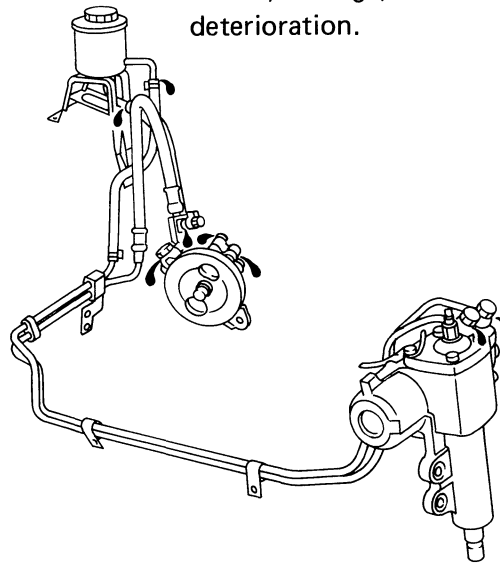
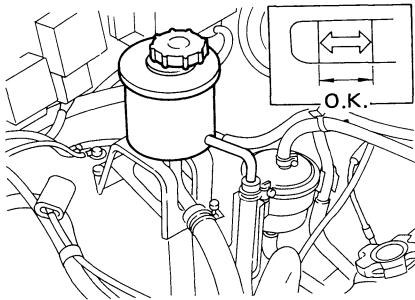

SMA443B

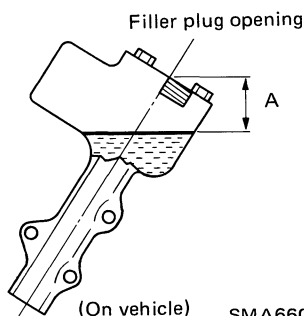

(On vehicle) SMA660B

Checking Steering Gear

- Check steering gear for oil level and leakage.
- Check oil level.

Oil level:

Distance "A"

43 mm (1.69 in) or less

Be careful not to overflow gear oil when filling up.

CHASSIS AND BODY MAINTENANCE

Body

LUBRICATING HOOD LATCHES, LOCKS AND HINGES

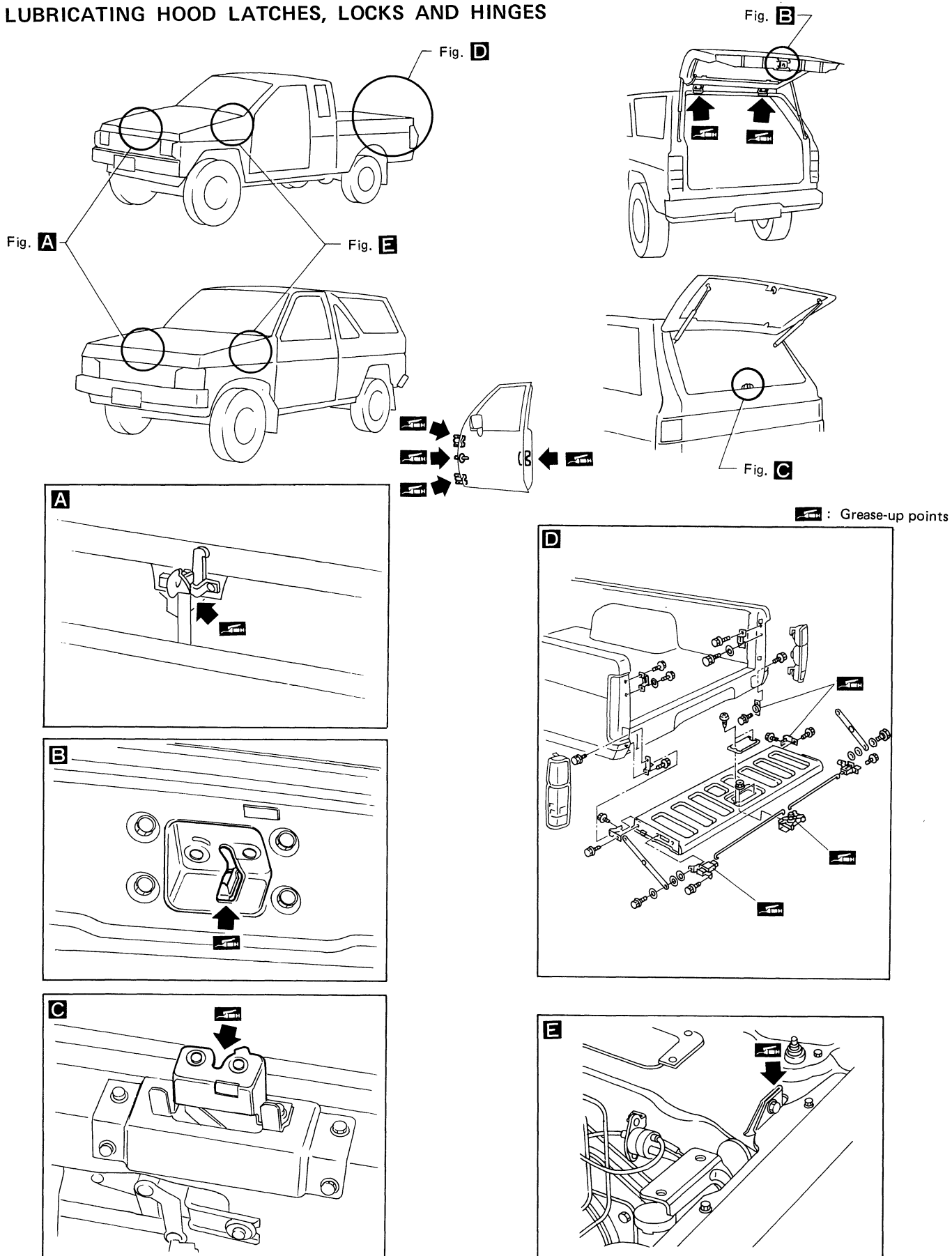

CHASSIS AND BODY MAINTENANCE

Body (Cont'd)

CHECKING SEAT BELTS, BUCKLES, RETRACTORS, ANCHORS AND ADJUSTERS

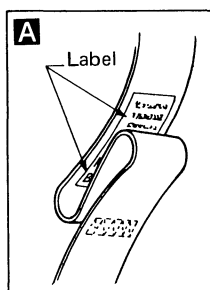
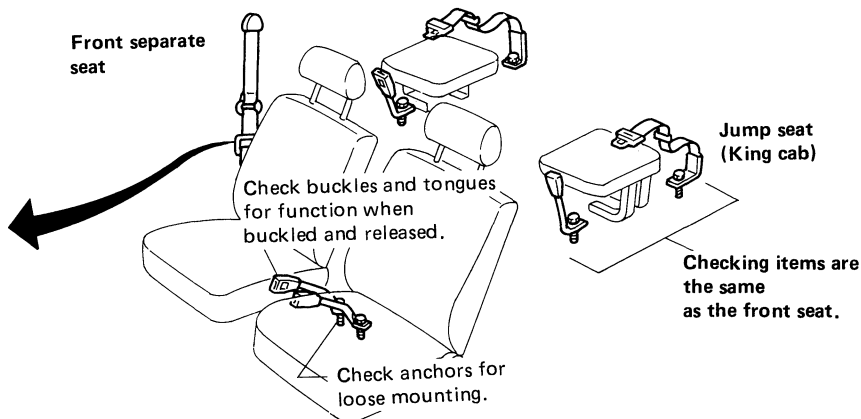
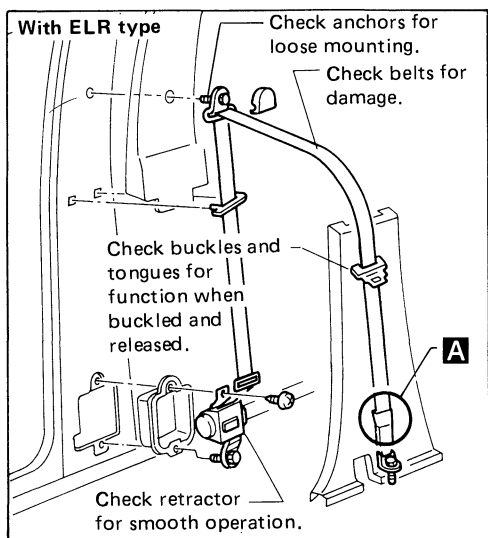

For front seat belt, shock absorber type belt has been used. Replace the belt when loop has been pulled out and "REPLACE BELT" is visible because this seat belt has a loop of webbing under the sleeve.

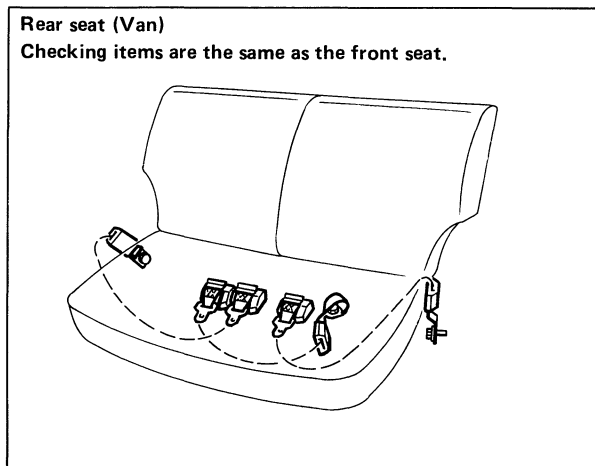
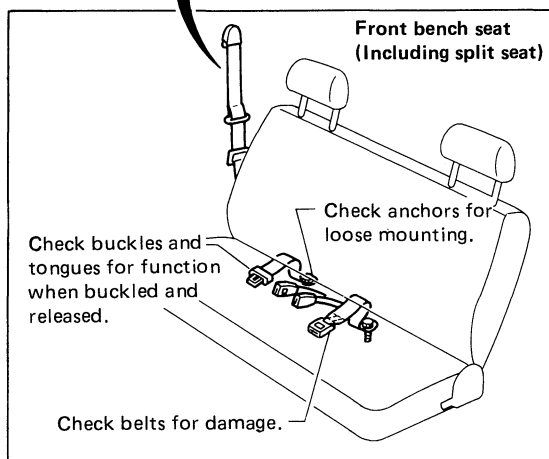

CAUTION:

1. If the vehicle is collided or overturned, replace the entire belt assembly, regardless of nature of accident.
2. If the condition of any component of a seat belt is questionable, do not repair seat belt, but replace it as a belt assembly.
3. If webbing is cut, frayed, or damaged, replace belt assembly.
4. Do not spill drinks, oil, etc. on inner lap belt buckle. Never oil tongue and buckle.
5. Use a NISSAN genuine seat belt assembly.

Anchor bolt:

: 35.8 - 45.6 N-m
(3.65 - 4.65 kg-m,
26.4 - 33.6 ft-lb)

SERVICE DATA AND SPECIFICATIONS (S.D.S.)

Engine Maintenance

INSPECTION AND ADJUSTMENT

Drive belt deflection

Unit: mm (in)

	Used belt deflection		Set deflection of new belt
	Limit	Adjusted deflection	
Alternator	12 (0.47)	6 - 8 (0.24 - 0.31)	5 - 7 (0.20 - 0.28)
Air conditioner compressor	16 (0.63)	9 - 11 (0.35 - 0.43)	7 - 9 (0.28 - 0.35)
Power steering oil pump	17 (0.67)	11 - 13 (0.43 - 0.51)	9 - 11 (0.35 - 0.43)
Applied pushing force	98 N (10 kg, 22 lb)		

Inspect drive belt deflections when engine is cold.
If engine is hot, check deflections in 30 minutes or more.

TIGHTENING TORQUE

Item	N·m	kg·m	ft·lb
Alternator adjuster lock bolt	14 - 17	1.4 - 1.7	10 - 12
Power steering pump adjusting bolt	16 - 21	1.6 - 2.1	12 - 15
Idler adjuster lock nut	31 - 42	3.2 - 4.3	23 - 31
Oil pan drain plug	29 - 39	3.0 - 4.0	22 - 29
Spark plug	20 - 29	2.0 - 3.0	14 - 22

Oil capacity (Approximately refill capacity)

Unit: ℓ (US qt, Imp qt)

	2WD	4WD
With oil filter change	4.0 (4-1/4, 3-1/2)	3.4 (3-5/8, 3)
Without oil filter change	3.6 (3-7/8, 3-1/8)	3.0 (3-1/8, 2-5/8)

Coolant capacity

Unit: ℓ (US qt, Imp qt)

Refill capacity (Without reservoir tank)	9.9 (10-1/2, 8-3/4)
Reservoir tank	0.6 (5/8, 1/2)

Spark plug

Standard type	BCPR5ES-11
Hot type	BCPR4ES-11
Cold type	BCPR6ES-11
Plug gap	1.0 - 1.1 mm (0.039 - 0.043 in)

Idle speed

Idle speed	rpm	M/T: 800±50 A/T: 700±50 (in "D" position)
------------	-----	--

SERVICE DATA AND SPECIFICATIONS (S.D.S.)

Engine Maintenance (Cont'd)

INSPECTION AND ADJUSTMENT

Drive belt deflection

Unit: mm (in)

	Used belt deflection		Set deflection of new belt
	Limit	Adjusted deflection	
Alternator	16 (0.63)	9 - 11 (0.35 - 0.43)	7 - 9 (0.28 - 0.35)
Air conditioner compressor	13 (0.51)	8 - 10 (0.31 - 0.39)	6 - 8 (0.24 - 0.31)
Power steering oil pump	16 (0.63)	10 - 12 (0.39 - 0.47)	8 - 10 (0.31 - 0.39)
Applied pushing force	98 N (10 kg, 22 lb)		

Inspect drive belt deflections when engine is cold.

If engine is hot, check deflections in 30 minutes or more.

Oil capacity (Approximate refill capacity)

Unit: ℓ (US qt, Imp qt)

	2WD	4WD
With oil filter change	3.8 (4, 3-3/8)	4.3 (4-1/2, 3-3/4)
Without oil filter change	3.3 (3-1/2, 2-7/8)	3.8 (4, 3-3/8)

Coolant capacity

Unit: ℓ (US qt, Imp qt)

Refill capacity (without reservoir tank)	8.2 (8-5/8, 7-1/4)
Reservoir tank	0.6 (5/8, 1/2)

Spark plug

	Intake and Exhaust sides
Standard type	BPR5ES
Hot type	BPR4ES
Cold type	BPR6ES
Plug gap	0.8 - 0.9 mm (0.031 - 0.035 in)

Valve clearance

Unit: mm (in)

Intake	0.30 (0.012)
Exhaust	0.30 (0.012)

Idle speed

Idle speed	rpm	M/T 800±50 A/T 650±50 (in "D" position)
------------	-----	--

TIGHTENING TORQUE

Item	N-m	kg-m	ft-lb
Alternator adjuster lock bolt	8 - 11	0.8 - 1.1	5.8 - 8.0
Power steering pump adjusting bolt	16 - 22	1.6 - 2.2	12 - 16
Idler adjuster lock nut	16 - 22	1.6 - 2.2	12 - 16
Oil pan drain plug	29 - 39	3.0 - 4.0	22 - 29
Spark plug	20 - 29	2.0 - 3.0	14 - 22
Intake and exhaust valve pivot lock nut	16 - 22	1.6 - 2.2	12 - 16

Chassis and Body Maintenance

INSPECTION AND ADJUSTMENT

Clutch

Unit: mm (in)

Item	Engine	
	Z-engines	VG-engines
Pedal height "H"	236 - 246 (9.29 - 9.69)	227 - 237 (8.94 - 9.33)
Pedal free play "A"	1 - 1.5 (0.039 - 0.059)	

Front axle and front suspension

Wheel bearing preload (2WD)

Wheel bearing axial play	0 (0)
mm (in)	
Wheel bearing nut	
Tightening torque	34 - 39
N·m (kg·m, ft·lb)	(3.5 - 4.0, 25 - 29)
Return angle	45°
degree	
Wheel bearing starting torque	
At wheel hub bolt	
With new grease seal	9.8 - 28.4
N (kg, lb)	(1.0 - 2.9, 2.2 - 6.4)
With used grease seal	9.8 - 23.5
N (kg, lb)	(1.0 - 2.4, 2.2 - 5.3)

Wheel bearing preload (4WD)

Wheel bearing lock nut	
Tightening torque	78 - 98 (8 - 10, 58 - 72)
N·m (kg·m, ft·lb)	
Retightening torque after loosening wheel bearing lock nut	0.5 - 1.5 (0.05 - 0.15, 0.4 - 1.1)
N·m (kg·m, ft·lb)	
Axial end play	0 (0)
mm (in)	
Starting force at wheel hub bolt	A
N (kg, lb)	
Turning angle	15° - 30°
degrees	
Starting force at wheel hub bolt	B
N (kg, lb)	
Wheel bearing preload at wheel hub bolt	
N (kg, lb)	
B-A	7.06 - 20.99 (0.72 - 2.14, 1.59 - 4.72)

SERVICE DATA AND SPECIFICATIONS (S.D.S.)

Chassis and Body Maintenance (Cont'd)

Vehicle posture (Unladen*1)

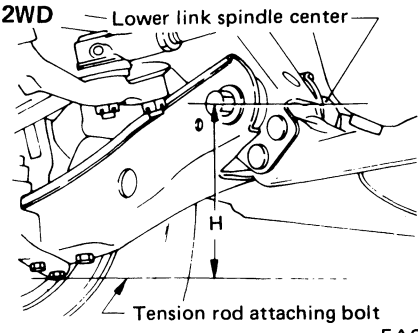
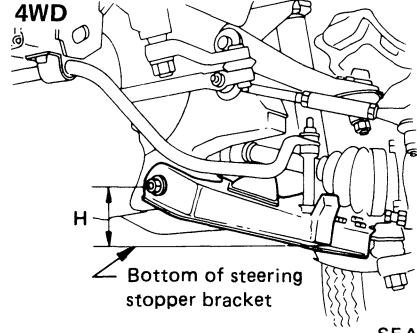
		A SERVICE CHECKING		A SERVICE SETTING	
		2WD	4WD	2WD	4WD
Applied model					
Dimension "H"	mm (in)	108 - 118 (4.25 - 4.65) [113±5 (4.45±0.20)]	41 - 51 (1.61 - 2.01) [46±5 (1.81±0.20)]	113±2 (4.45±0.08)	46±2 (1.81±0.08)
		 <p style="text-align: center;">2WD Lower link spindle center Tension rod attaching bolt FA681</p>		 <p style="text-align: center;">4WD Bottom of steering stopper bracket SFA535</p>	

Wheel alignment (Unladen*1)

		B SERVICE CHECKING		B SERVICE SETTING	
		2WD	4WD	2WD	4WD
Applied model					
Camber	degree	-20' to 1° 10' [25'±45']	-5' to 1° 25' [40'±45']	25'±30'	40'±30'
Caster	degree	-23' to 1° 07' [22'±45']	33' - 2° 03' [1° 18'±45']	22'±30'	1° 18'±30'
Kingpin inclination	degree	8° 20' - 9° 50' [9° 05'±45']	7° 21' - 8° 51' [8° 06'±45']	9° 05'±30'	8° 06'±30'
Toe-in (Total toe-in)	mm (in) degree				
Radial tire		1 - 5 (0.04 - 0.20) 7' - 27' [3±2 (0.12±0.08)] 17'±10'	2 - 6 (0.08 - 0.24) 10' - 28' [4±2 (0.16±0.08)] 19'±9' 0 - 4 (0 - 0.16)*2 0' - 19' [2±2 (0.08±0.08)] 9.5'±9.5'	3±1 (0.12±0.04) 17'±5'	4±1 (0.16±0.04) 17'±5' 2±1 (0.08±0.04)*2 10'±5'
Side to side caster difference	degree	45' or less		45' or less	
Side to side camber difference	degree	45' or less		45' or less	

*1: Tankful of fuel, radiator coolant and engine oil full. Spare tire, jack, hand tools, mats in designated positions.

*2: Van and Wagon models

SERVICE DATA AND SPECIFICATIONS (S.D.S.)

Chassis and Body Maintenance (Cont'd)

Brake

Unit: mm (in)

Disc brake			
Pad repair limit		2.0 (0.079)	
Rotor thickness repair limit			
CL28VA		20 (0.79)	
CL28VD		24 (0.94)	
AD14VB		16 (0.63)	
Drum brake			
Drum inner dia. repair limit			
LT26B		261.5 (10.30)	
DS25B, DS25C, DS25D		255.5 (10.06)	
DS22		221.5 (8.72)	
DS19HB		191.0 (7.52)	
Lining wear limit		1.5 (0.059)	
Pedal free height	A/T	212 - 222 (8.35 - 8.74)	
	M/T	209 - 219 (8.23 - 8.62)	
Pedal depressed height		120 (4.72) or more	
Pedal free play		1.0 - 3.0 (0.039 - 0.118)	
Parking brake Number of notches	Center lever type	Truck	10 - 12
		Van & Wagon	7 - 9
	Stick lever type	2WD	10 - 12
		4WD	9 - 11

Wheel and tire

Tire inflation

Proper tire pressures are shown on the tire placard affixed into the glove box of vehicle.

Tire pressure should be checked when tires are COLD.

Item	Wheel Model	Steel		Aluminum
		2WD	4WD	2WD, 4WD
Wheel rim lateral runout and radial runout mm (in)		—		0.3 (0.012) or less
Average value				
Right and left radial runout mm (in)		0.5 (0.020) or less 0.8 (0.031)*1 or less	0.8 (0.031) or less	—
Right and left lateral runout mm (in)		0.8 (0.031) or less		—
Difference between right and left radial runout mm (in)		0.5 (0.020) or less		0.2 (0.008) or less
Wheel balance (Maximum allowable unbalance at rim flange) g (oz)		10 (0.35)		
Tire balancing weight g (oz)		5 - 60 (0.18 - 2.12) Spacing 5 (0.18)		

*1: Model equipped with 6-JJx14 wheel

SERVICE DATA AND SPECIFICATIONS (S.D.S.)

Chassis and Body Maintenance (Cont'd)

TIGHTENING TORQUE

Unit	N-m	kg-m	ft-lb
Manual transmission			
Drain and filler plugs	25 - 34	2.5 - 3.5	18 - 25
Transfer			
Drain and filler plugs	25 - 34	2.5 - 3.5	18 - 25
Differential carrier			
Drain and filler plugs (Except C200 type)			
Front	39 - 59	4 - 6	29 - 43
Rear	59 - 98	6 - 10	43 - 72
Drain plug*2	59 - 98	6 - 10	43 - 72
Filler plug*2	39 - 59	4 - 6	29 - 43
Front axle and front suspension			
Tie-rod lock nut (4WD)	78 - 98	8.0 - 10.0	58 - 72
Tie-rod clamp bolt (2WD)	14 - 20	1.4 - 2.0	10 - 14
Wheel nut			
Single tire	118 - 147	12 - 15	87 - 108
Aluminum wheel	118 - 147	12 - 15	87 - 108

*2: Model equipped with C200

ENGINE MECHANICAL

SECTION **EM**

EM

CONTENTS

PREPARATION	EM- 3
OIL PAN REMOVAL AND INSTALLATION	EM- 8
ENGINE REMOVAL AND INSTALLATION	EM-12

VG30i

ENGINE COMPONENTS – Outer Parts –	EM-17
CHECKING COMPRESSION PRESSURE	EM-19
TIMING BELT	EM-20
TIMING BELT – Removal –	EM-21
TIMING BELT – Inspection –	EM-22
TIMING BELT – Installation –	EM-23
CYLINDER HEAD	EM-26
CYLINDER HEAD – Removal –	EM-27
CYLINDER HEAD – Disassembly –	EM-28
CYLINDER HEAD – Inspection –	EM-29
CYLINDER HEAD – Assembly –	EM-35
CYLINDER HEAD – Installation –	EM-36
OIL SEAL REPLACEMENT	EM-39
ENGINE OVERHAUL	EM-41
ENGINE OVERHAUL – Disassembly –	EM-42
ENGINE OVERHAUL – Inspection –	EM-42
ENGINE OVERHAUL – Assembly –	EM-49
SERVICE DATA AND SPECIFICATIONS (S.D.S.)	EM-53

Contents (Cont'd)

	Z24i	
--	------	--

ENGINE COMPONENTS – Outer Parts –	EM-61
CHECKING COMPRESSION PRESSURE	EM-62
TIMING CHAIN	EM-63
TIMING CHAIN – Removal –	EM-64
TIMING CHAIN – Inspection –	EM-67
TIMING CHAIN – Installation –	EM-68
CYLINDER HEAD	EM-72
CYLINDER HEAD – Removal –	EM-73
CYLINDER HEAD – Disassembly –	EM-75
CYLINDER HEAD – Inspection –	EM-76
CYLINDER HEAD – Assembly –	EM-82
CYLINDER HEAD – Installation –	EM-84
OIL SEAL REPLACEMENT	EM-87
ENGINE OVERHAUL	EM-89
ENGINE OVERHAUL – Disassembly –	EM-90
ENGINE OVERHAUL – Inspection –	EM-91
ENGINE OVERHAUL – Assembly –	EM-97
SERVICE DATA AND SPECIFICATIONS (S.D.S.)	EM-99

PREPARATION

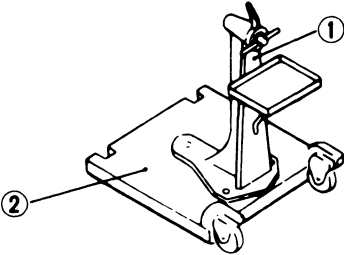
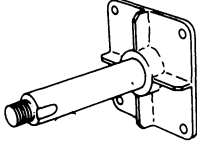
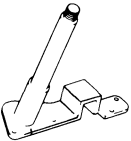
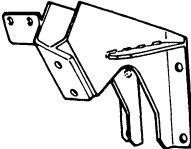
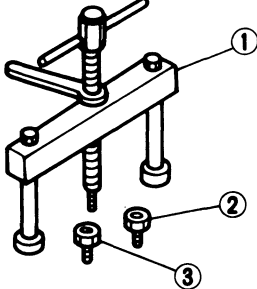
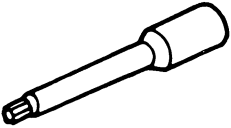
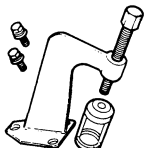

SPECIAL SERVICE TOOLS

Tool number (Kent-Moore No.) Tool name	Description	Engine application		
		VG30i	Z24i	
ST0501S000 (-) Engine stand assembly ① ST05011000 (-) Engine stand ② ST05012000 (-) Base		Disassembling and assembling	X	X
KV10106500 (-) Engine stand shaft			X	-
KV10105001 (-) Engine attachment			-	X
KV10110001 (-) Engine sub-attachment			X	-
KV101041S0 (-) Crankshaft main bearing cap puller ① ST16511000 (-) Crankshaft main bearing puller ② ST16512001 (-) Adapter ③ ST16701001 (-) Adapter		Remvoing main bearing cap	-	X
ST10120000 (J24239-01) Cylinder head bolt wrench		Loosening and tightening cylinder head bolt	X	-
KV10110600 (J33986) Valve spring compressor		Disassembling and assembling valve components	X	-

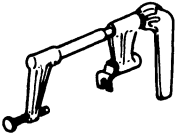
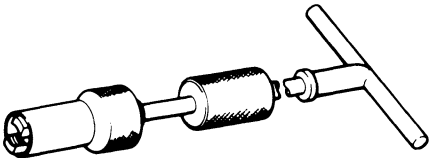
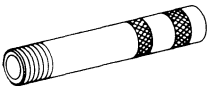
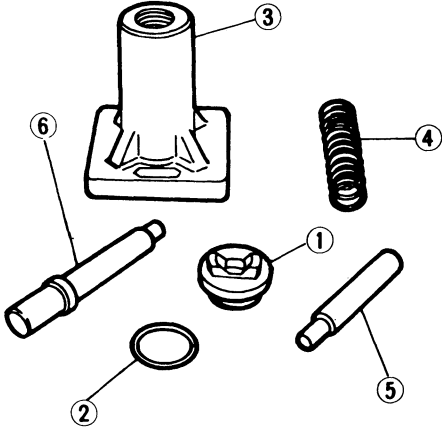
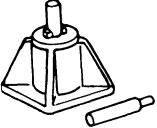
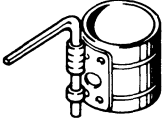
PREPARATION

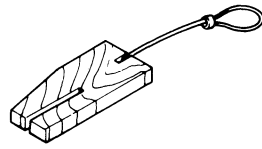
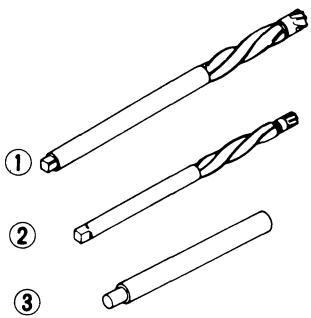

Tool number (Kent-Moore No.) Tool name	Description	Engine application		
		VG30i	Z24i	
ST12070000 (J8062) Valve lifter		Disassembling and assembling valve components	—	X
KV10107900 (—) Valve lip seal puller		Disassembling valve lip seal	X	X
KV10107501 (—) Valve oil seal drift		Installing valve oil seal	X	—
KV10110300 (—) Piston pin press stand assembly ① KV10110310 (—) Cap ② KV10110330 (—) Spacer ③ ST13030020 (—) Press stand ④ ST13030030 (—) Spring ⑤ KV10110340 (—) Drift ⑥ KV10110320 (—) Center shaft		Disassembling and assembling piston with connecting rod	X	—
ST13030001 (J26365-A) Piston pin press stand		Removing piston pin	—	X
EM03470000 (J8037) Piston ring compressor		Installing piston into cylinder	X	X

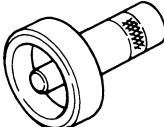
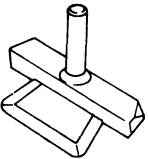
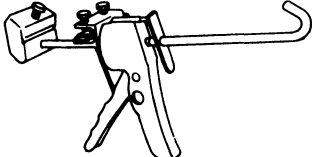
PREPARATION

Tool number (Kent-Moore No.) Tool name	Description	Engine application		
		VG30i	Z24i	
ST19320000 (J22700) Oil filter wrench		Installing oil filter	—	X
KV10105800 (J25660-C) Chain stopper		Supporting chain when removing cylinder head	—	X
KV101039S0 (—) Valve guide reamer set ① ST11081000 (J25618-3) Reamer [12.2 mm (0.480 in)] dia. ② ST11032000 (J25618-2) Reamer [8.0 mm (0.315 in)] dia. ③ ST11320000 (J25618-1) Valve guide drift		Reaming valve guide	—	X
ST11650001 (—) Valve seat cutter set		Cutting valve seat	—	X
ST16610001 (J23907) Pilot bushing puller			X	X
KV10105500 (—) Crankshaft rear oil seal drift		Installing crankshaft rear oil seal	—	X
KV10111100 (—) Seal cutter		Removing oil pan	X	X
WS39930000 (—) Tube presser		Pressing the tube of liquid gasket	X	X

PREPARATION

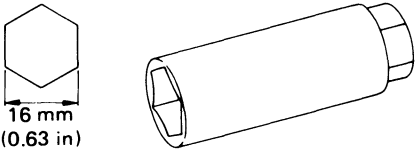
COMMERCIAL SERVICE TOOLS

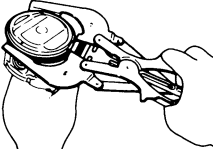
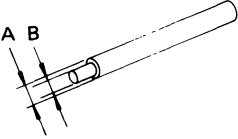
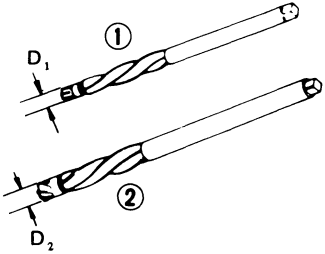
Tool name	Description	Engine application		
		VG30i	Z24i	
Spark plug wrench		Removing and installing spark plug	X	—
Pulley holder		Holding camshaft pulley while tightening or loosening camshaft bolt	X	—
Valve seat cutter set		Finishing valve seat dimensions	X	—
Piston ring expander		Removing and installing piston ring	X	—
Valve guide drift	<p>Intake & Exhaust: A = 10.5 mm (0.413 in) dia. B = 6.6 mm (0.260 in) dia.</p> 	Removing and installing valve guide	X	—
Valve guide reamer	<p>Intake: D₁ = 7.0 mm (0.276 in) dia. D₂ = 11.2 mm (0.441 in) dia. Exhaust: D₁ = 8.0 mm (0.315 in) dia. D₂ = 12.2 mm (0.480 in) dia.</p> 	Reaming valve guide (①) or hole for oversize valve guide (②)	X	—

PREPARATION

NOTE

OIL PAN REMOVAL AND INSTALLATION

Removal

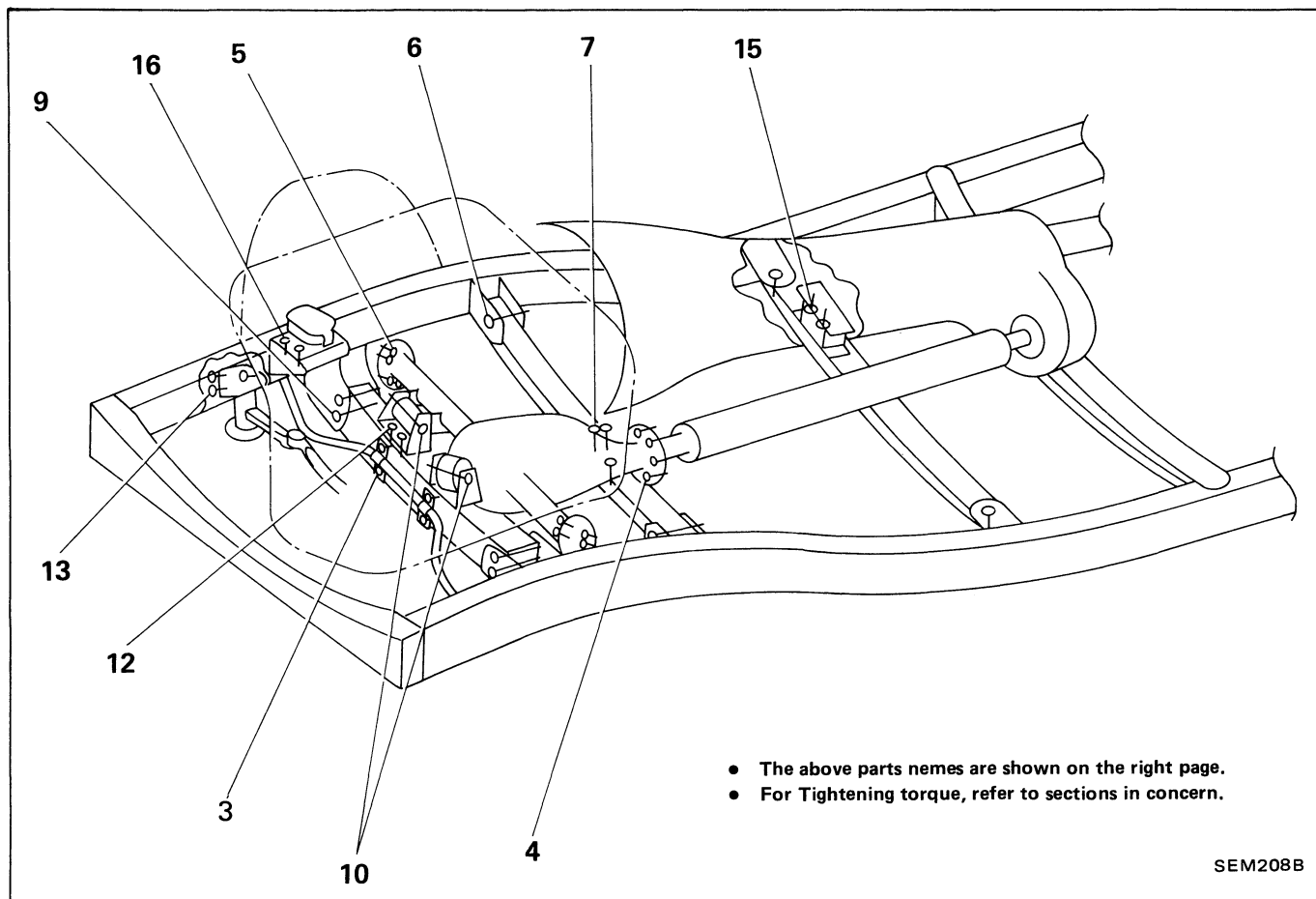

WARNING:

- a. Place vehicle on a flat and solid surface.
- b. Place chocks at front and rear of rear wheels.
- c. You should not remove oil pan until exhaust system and cooling system have completely cooled off. Otherwise, you may burn yourself and/or fire may break out in the fuel line.
- d. When remove front and/or rear engine mounting bolts or nuts, lift up slightly engine for safety work.

CAUTION:

- a. In lifting engine, be careful not to hit against adjacent parts, especially against accelerator wire casing end, brake tube and brake master cylinder.
- b. For tightening torque, refer to sections AT, MT and PD.

OIL PAN REMOVAL AND INSTALLATION

Removal (Cont'd)

Removal order and points	VG30i		Z24i	
	2WD model	4WD model	2WD model	4WD model
1 Remove undercover.	O	O	O	O
2 Drain engine oil.	O	O	O	O
3 Remove stabilizer bracket bolts (R.H. & L.H.).	O	-	-	-
4 Remove front propeller shaft from front differential carrier.	-	O	-	-
5 Remove front drive shaft fixing bolts (R.H. & L.H.).	-	O	-	-
6 Remove front differential carrier member bolt (R.H. & L.H.).	-	O	-	O
7 Remove front differential carrier fixing bolts and support it.	-	O	-	O
8 Remove front differential carrier bleeder hose.	-	O	-	-
9 Remove front suspension cross-member.	O	-	O	-
10 Remove differential front mounting bolts (R.H. & L.H.).	-	O	-	-
11 Remove front differential carrier.	-	O	-	-
12 Remove front differential carrier mounting bracket.	-	O	-	-
13 Remove idler arm.	O	O	-	-
14 Remove starter motor.	O	O	-	-
15 Remove transmission to rear engine mounting bracket nuts (R.H. & L.H.).	-	O	-	O
16 Remove engine mounting bolts or nuts (R.H. & L.H.).	-	O	-	O
17 Remove engine gussets.	O	O	-	-
18 Lift up engine. If necessary, disconnect exhaust tube.	-	O	-	O
19 Remove oil pan.	*	*	*	*

* Refer to next page.

OIL PAN REMOVAL AND INSTALLATION

Removal (Cont'd)

1. Remove oil pan bolts.

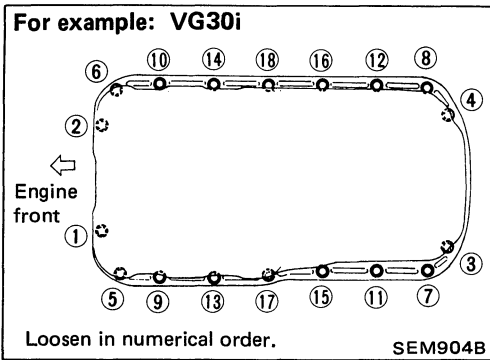

2. Remove oil pan.

(1) Insert Tool between cylinder block and oil pan.

- Do not drive seal cutter into oil pump or rear oil seal retainer portion, or aluminum mating face will be damaged.
- Do not insert screwdriver, or oil pan flange will be deformed.

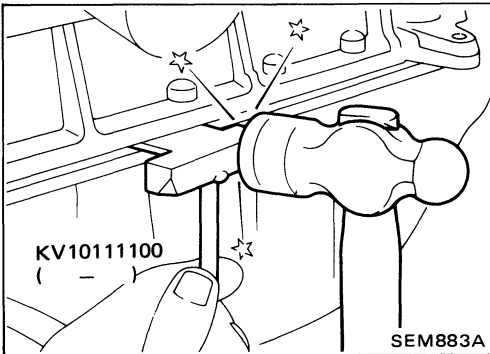

(2) Slide Tool by tapping its side with a hammer, and remove oil pan.

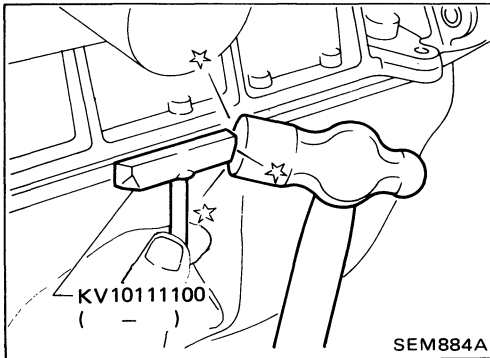

Installation

1. Before installing oil pan, remove all traces of liquid gasket from mating surface using a scraper.

- Also remove traces of liquid gasket from mating surface of cylinder block.

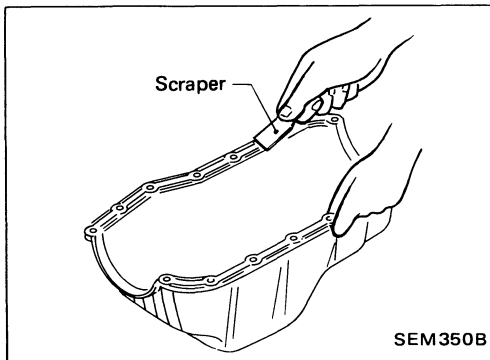

2. Apply sealant to oil pump gasket and rear oil seal retainer gasket. (VG30i)

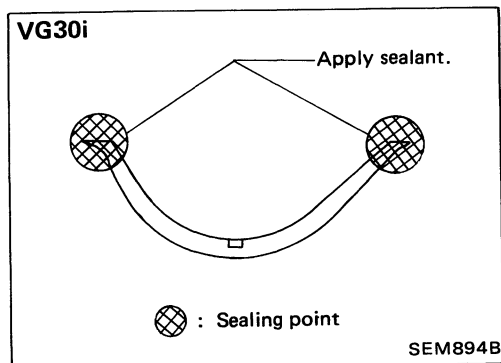

OIL PAN REMOVAL AND INSTALLATION

Installation (Cont'd)

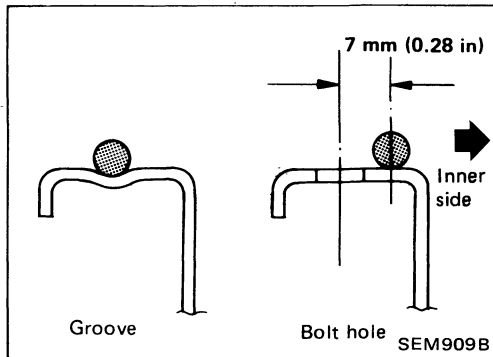
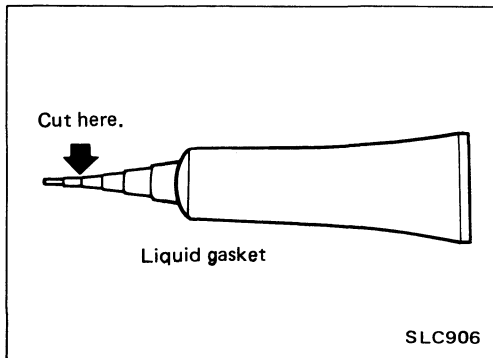
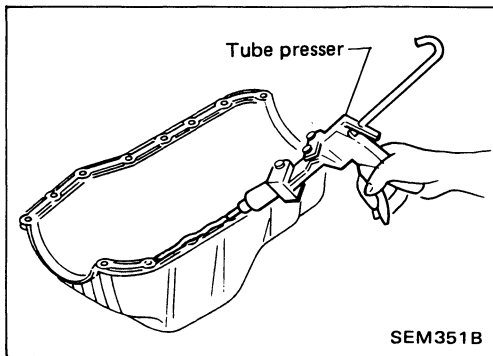

3. Apply a continuous bead of liquid gasket to making surface of oil pan.
 - Use Genuine Liquid Gasket or equivalent.

- Be sure liquid gasket is 3.5 to 4.5 mm (0.138 to 0.177 in) wide.

4. Apply liquid gasket to inner sealing surface instead of surface where there is no groove at bolt hole.
 - Attaching should be done within 5 minutes after coating.

5. Install oil pan.
 - Install bolts/nuts in their reverse order of removal.
 - Wait at least 30 minutes before refilling engine with oil.

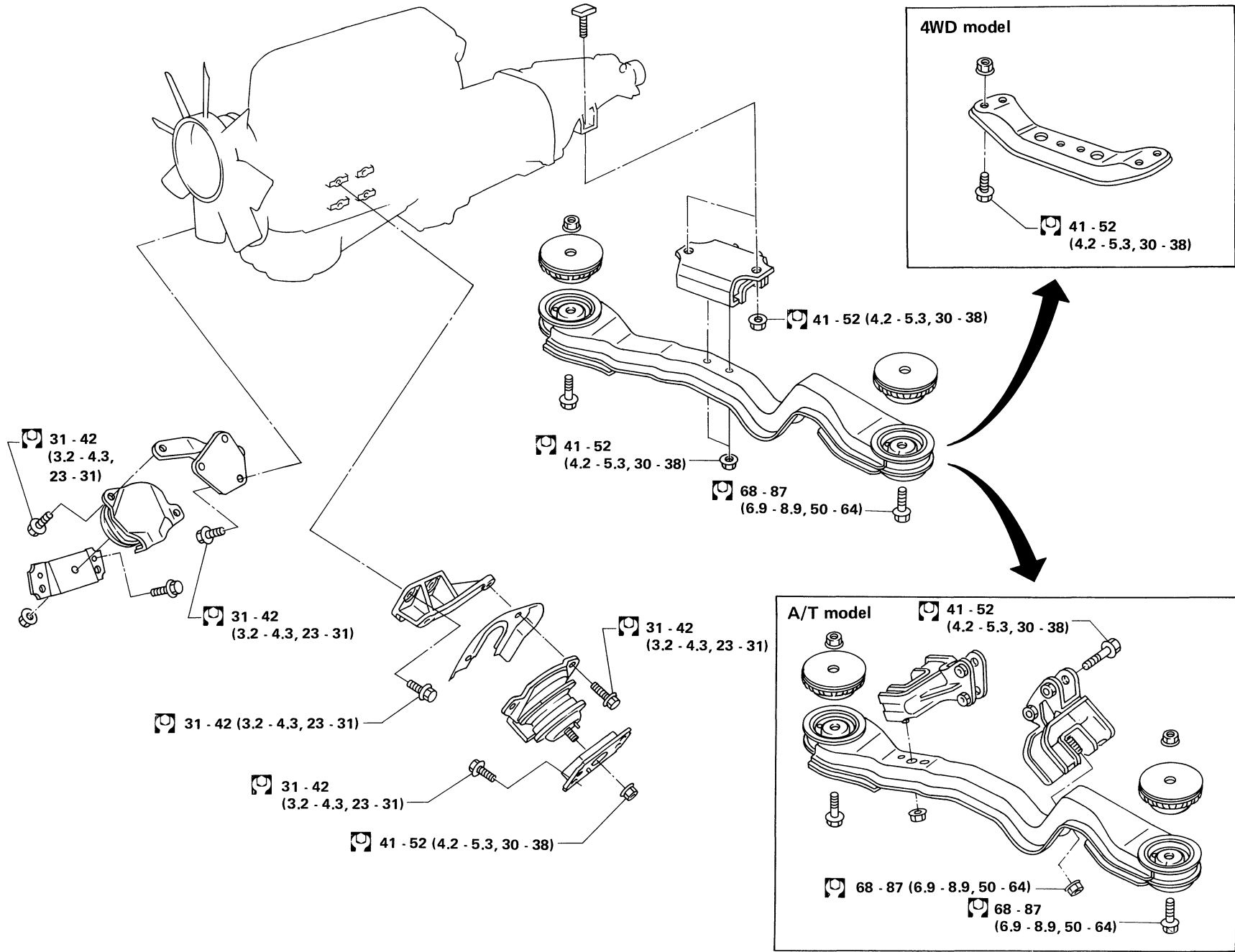

: N·m (kg·m, ft·lb)

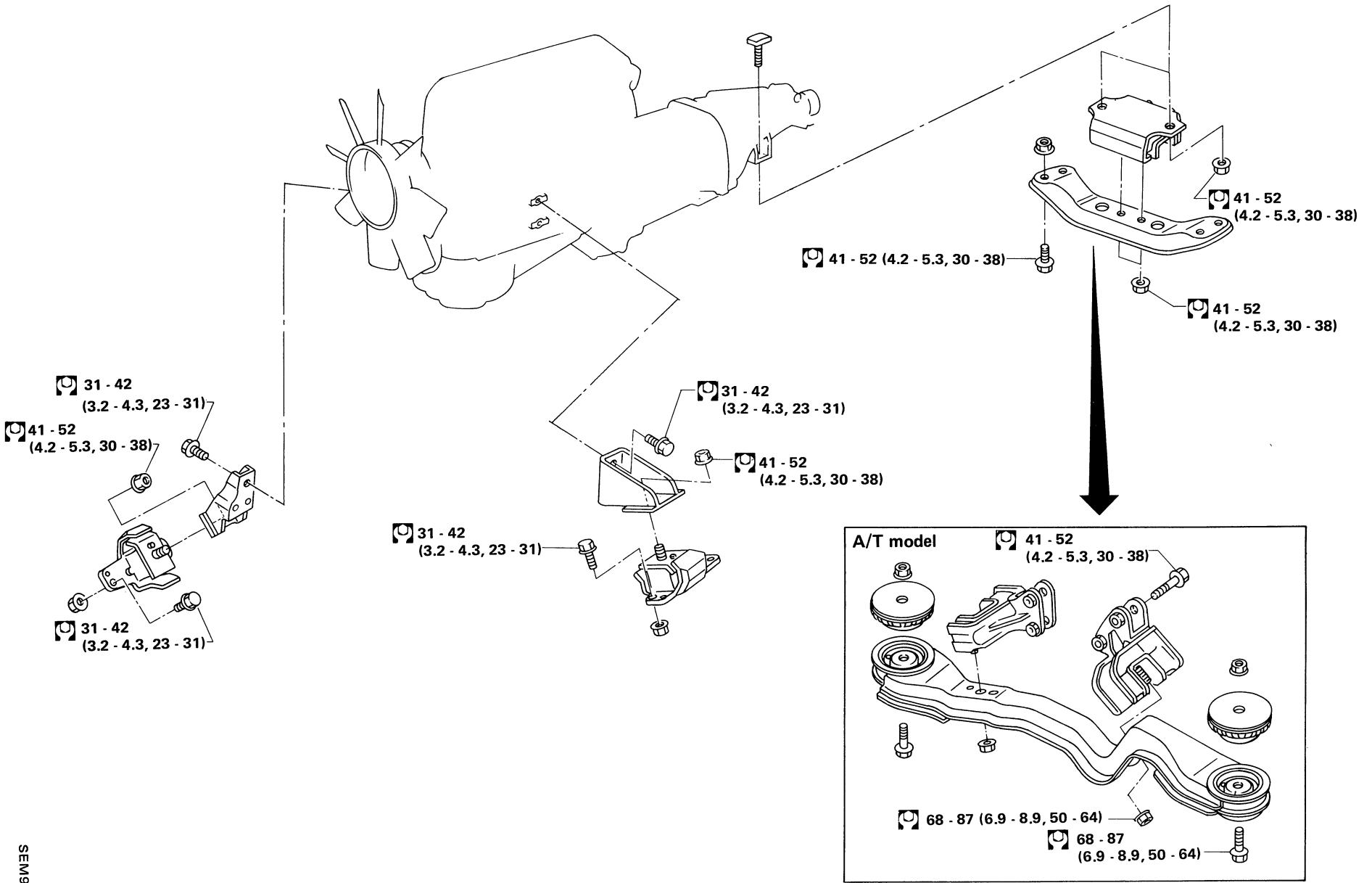

: N·m (kg·m, ft·lb)

SEM938B

ENGINE REMOVAL AND INSTALLATION

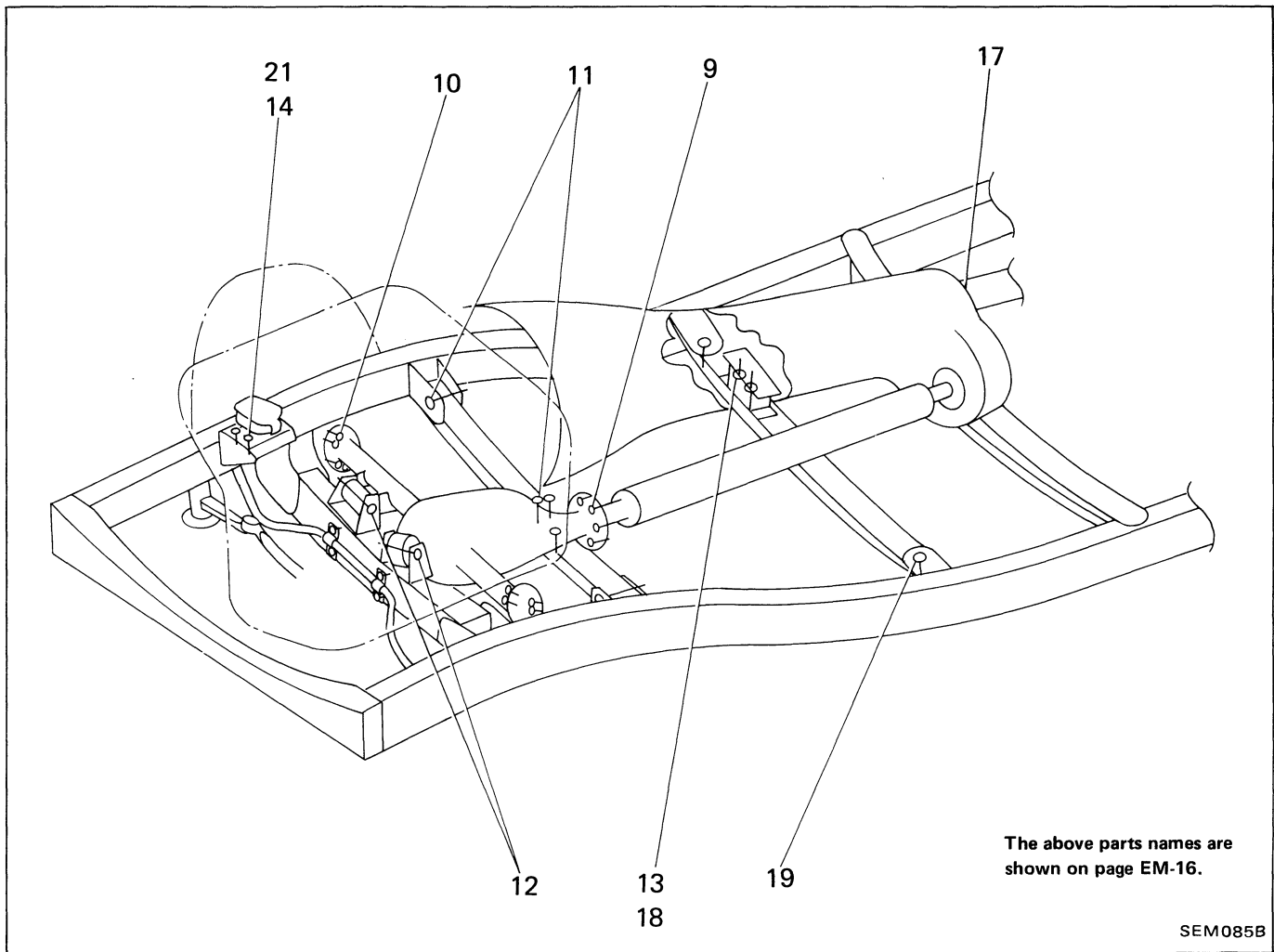

WARNING:

- a. Place vehicle on a flat and solid surface.
- b. Place chocks at front and back of rear wheels.
- c. Do not remove engine until exhaust system has completely cooled off.
Otherwise, you may burn yourself and/or fire may break out in the fuel line.
- d. For safety during subsequent steps, the tension of wires should be slackened against the engine.
- e. Before disconnecting fuel hose, release fuel pressure from fuel line.
Refer to "Releasing Fuel Pressure" in section EF & EC.
- f. Before removing front axle from transmission, place safety stands under designated front supporting points.
Refer to GI section for lifting points and towing.
- g. Be sure to hoist engine and transmission in a safe manner.
- h. For engines not equipped with engine slingers, attach proper slingers and bolts described in PARTS CATALOG.

ENGINE REMOVAL AND INSTALLATION

CAUTION:

- When lifting engine, be careful not to strike adjacent parts, especially the accelerator wire casing, brake lines, and brake master cylinder.

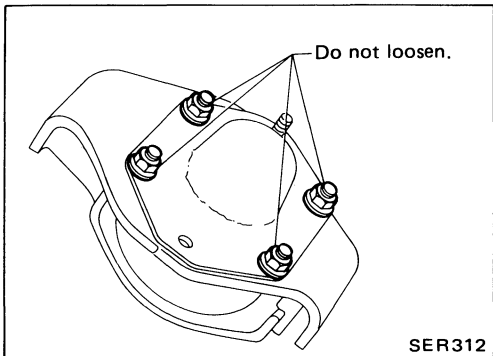

- Do not loosen front engine mounting insulator cover securing nuts.

When cover is removed, damper oil flows out and mounting insulator will not function.















For tightening torque, refer to sections AT, MT and PD.

For 4WD model, sealant should be applied between engine and transmission.

Refer to section MT.

ENGINE REMOVAL AND INSTALLATION

: N·m (kg-m, ft-lb)

Removal order and points	2WD model	4WD model	Remarks
1 Drain engine oil and coolant.	O	O	 29 - 39 (3.0 - 4.0, 22 - 29)
2 Remove radiator with shroud and cooling fan.	O	O	 Radiator 3 - 4 (0.3 - 0.4, 2.2 - 2.9) Cooling fan 6 - 10 (0.6 - 1.0, 4.3 - 7.2)
3 Remove undercover.	O	O	 3 - 4 (0.3 - 0.4, 2.2 - 2.9)
4 Remove A/C compressor and P/S pump.	O	O	-
5 Remove starter motor	-	O	 29 - 39 (3.0 - 4.0, 22 - 29)
6 Disconnect harness from starter motor.	O	-	-
7 Disconnect exhaust manifold from exhaust front tube.	O	O	 26 - 36 (2.7 - 3.7, 20 - 27)
8 Remove front exhaust tube.	O	O	 31 - 42 (3.2 - 4.3, 23 - 31)
9 Disconnect front propeller shaft from front differential carrier.	-	O	 39 - 44 (4.0 - 4.5, 29 - 33)
10 Remove front drive shaft fixing bolts (R.H. & L.H.).	-	O	 34 - 44 (3.5 - 4.5, 25 - 33)
11 Remove front differential carrier fixing bolts and remove front differential carrier member.	-	O	 Carrier bolts 68 - 87 (6.9 - 8.9, 50 - 64) Member bolts 54 - 64 (5.5 - 6.5, 40 - 47)
12 Remove differential front mounting bolts (R.H. & L.H.).	-	O	 68 - 87 (6.9 - 8.9, 50 - 64)
13 Remove transmission to rear engine mounting bracket nuts.	-	O	 41 - 52 (4.2 - 5.3, 30 - 38)
14 Remove front engine mounting bolts (R.H. & L.H.).	-	O	 31 - 42 (3.2 - 4.3, 23 - 31)
15 Lift up engine.	-	O	-
16 Remove front differential carrier.	-	O	-
17 Disconnect rear propeller shaft from transmission.	O	-	Refer to PD section.
18 Remove transmission to rear engine mounting bracket bolts.	O	-	 41 - 52 (4.2 - 5.3, 30 - 38)
19 Remove transmission member.	O	-	
20 Remove engine to transmission fixing bolts.	-	O	 Bolt length 16 or 25 mm (0.63 or 0.98 in) 29 - 39 (3.0 - 4.0, 22 - 29) Others 39 - 49 (4.0 - 5.0, 29 - 36)
21 Remove front engine mounting bolts (R.H. & L.H.).	O	-	 31 - 42 (3.2 - 4.3, 23 - 31)
22 Hang on and carry out engine.	O	O	-

Install engine in reverse order of removal.

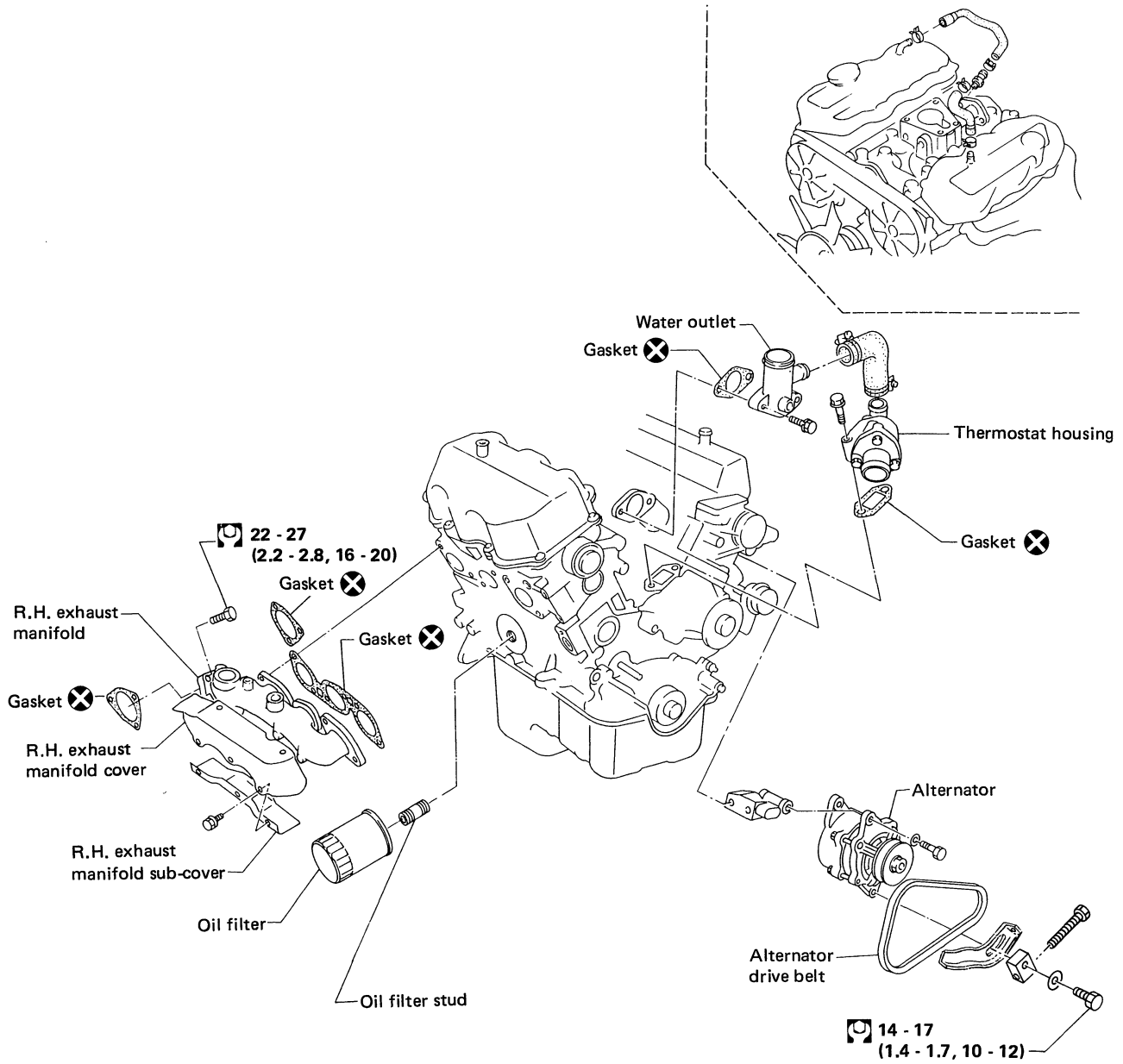

 : N-m (kg-m, ft-lb)

SEM901B

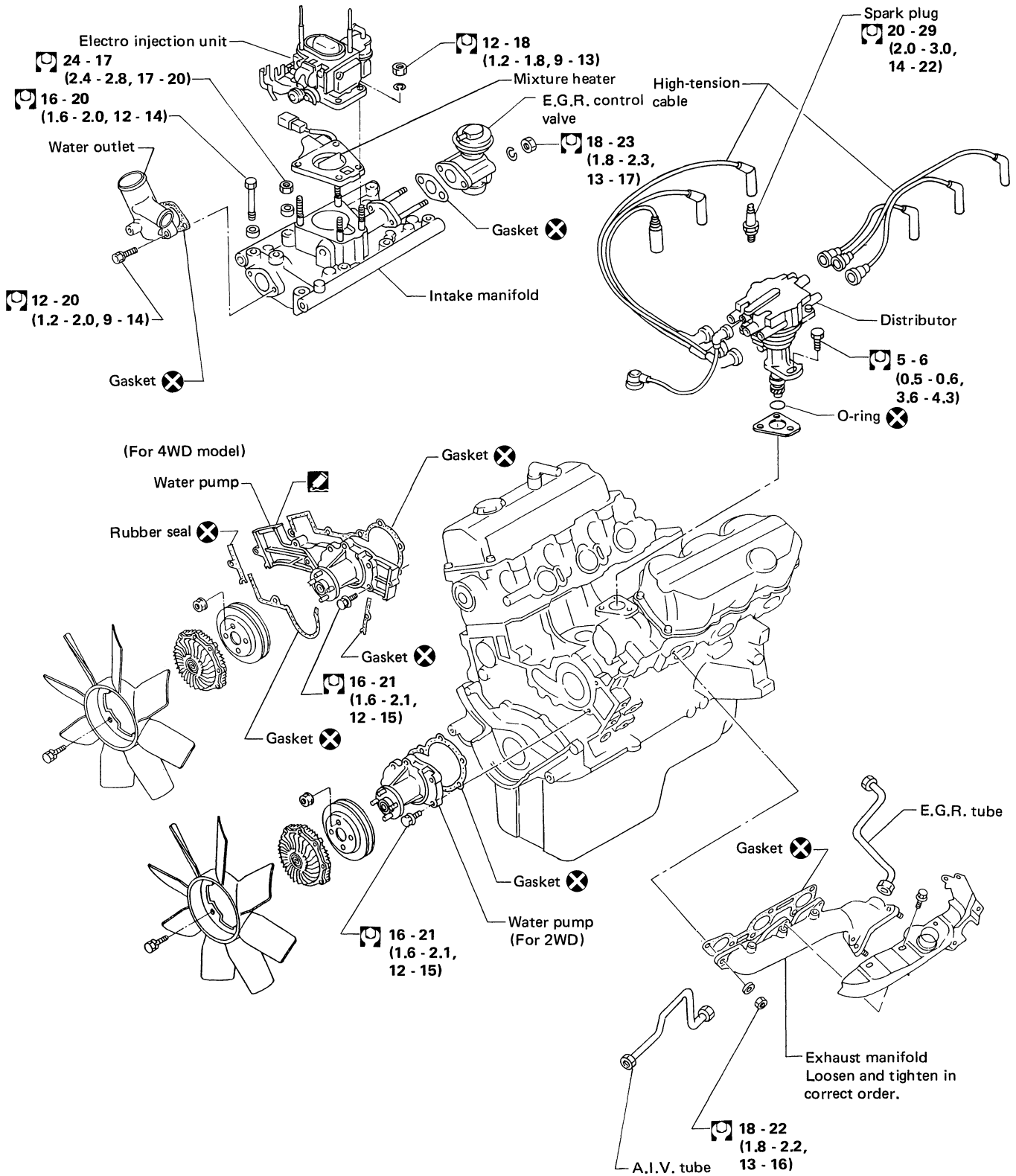

- Use new gaskets, O-ring and brazen washers.
- As for tightening order of exhaust manifolds and collector, refer to CYLINDER HEAD.

: N·m (kg·m, ft·lb)

SEM902B

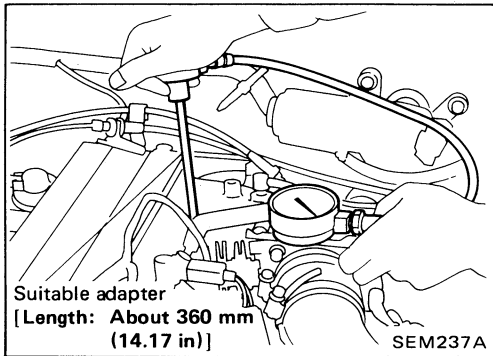
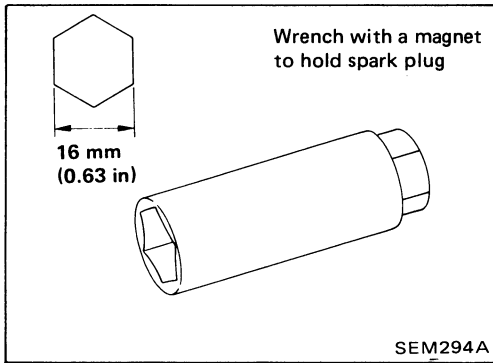

Measurement of Compression Pressure

1. Warm up engine.
 2. Turn ignition switch off.
 3. Removal all spark plugs.
 4. Disconnect distributor center cable.
 5. Release fuel pressure.
Refer to "Releasing Fuel Pressure" in section EF & EC.
6. Attach a compression tester to No. 1 cylinder.
 7. Depress accelerator pedal fully to keep throttle valve wide open.
 8. Crank the engine and read the highest gauge indication.
 - **Always use a fully-charged battery to obtain specified engine revolution.**
- Compression pressure:**
kPa (kg/cm², psi)/rpm
- | |
|---|
| Standard |
| 1,196 (12.2, 173)/300 |
| Minimum |
| 883 (9.0, 128)/300 |
| Difference limit between cylinders |
| 98 (1.0, 14)/300 |
9. Repeat the measurement on each cylinder as shown above.
 10. If cylinder compression in one or more cylinders is low, pour a small amount of engine oil into cylinders through the spark plug holes and retest compression.
 - **If adding oil helps the compression, piston rings may be worn or damaged. If so, replace the piston rings after checking piston.**
 - **If pressure stays low, a valve may be sticking or seating improperly. Inspect and repair valve and valve seat. (Refer to S.D.S.). If the valve or valve seat is damaged excessively, replace them.**
 - **If compression in any two adjacent cylinders is low and if adding oil does not help the compression, there is leakage past the gasket surface. If so, replace cylinder head gasket.**

CAUTION:

- Do not bend or twist timing belt.
- After removing timing belt, do not turn crankshaft and camshaft separately because valves will strike piston heads.
- Make sure that timing belt, camshaft sprocket, crankshaft sprocket and belt tensioner are clean and free from oil and water.

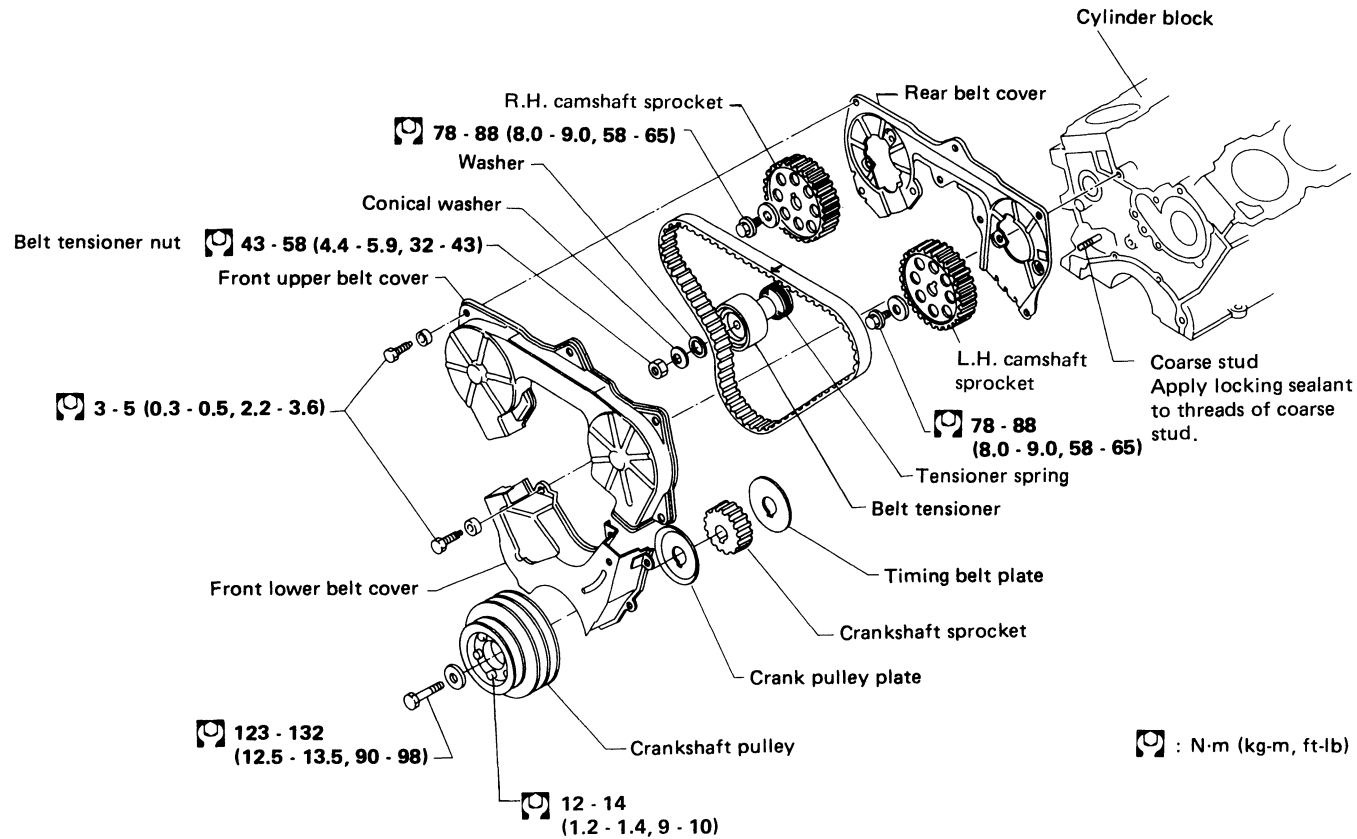

Removal

1. Remove radiator shroud, fan and pulleys.
Refer to ENGINE COOLING SYSTEM — Radiator (section LC).
2. Drain coolant from radiator and remove water pump hose.
Be careful not to spill coolant on drive belts.
3. Remove all spark plugs.
4. Remove the following belts.
 - Power steering drive belt
 - Compressor drive belt
 - Alternator drive belt
5. Remove suction pipe bracket of coolant and lower hose from suction pipe.
6. Remove all spark plugs.

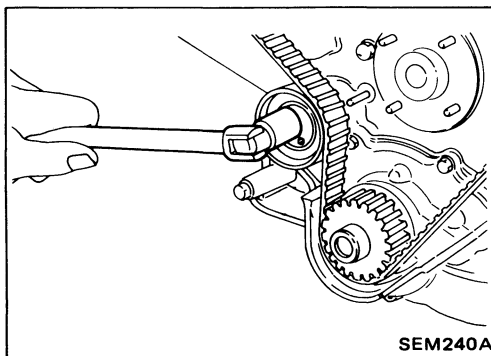
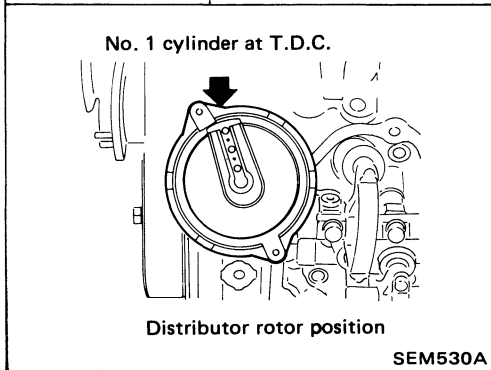
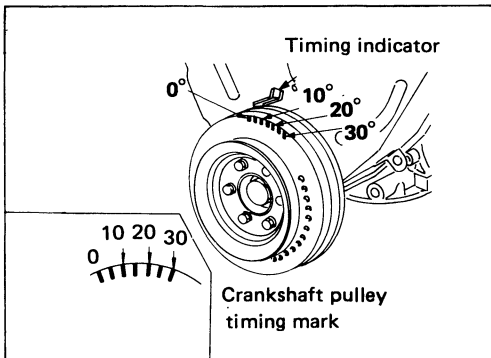

7. Set No. 1 cylinder at T.D.C. on its compression stroke.
8. Remove idler bracket of the compressor drive belt and crankshaft pulley.
9. Remove front upper and lower belt covers.
10. Loosen timing belt tensioner nut, turn tensioner, and then remove timing belt.

Inspection

Visually check the condition of the timing belt.
Replace if any abnormality is found.

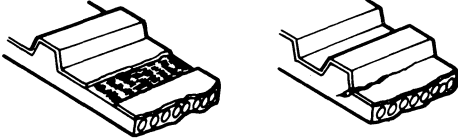
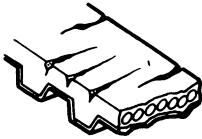
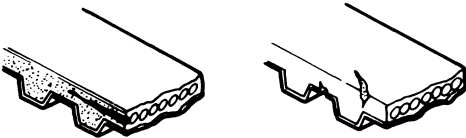
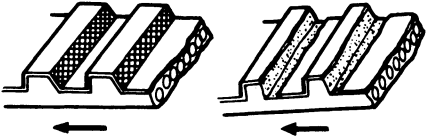
Item to check	Problem	Cause
Tooth is broken/ tooth root is cracked.	 <p style="text-align: right;">SEM394A</p>	<ul style="list-style-type: none"> ● Camshaft jamming ● Distributor jamming ● Damaged camshaft/crankshaft oil seal
Back surface is cracked/worn.	 <p style="text-align: right;">SEM395A</p>	<ul style="list-style-type: none"> ● Tensioner jamming ● Overheated engine ● Interference with belt cover
Side surface is worn.	 <ul style="list-style-type: none"> ● Belt corners are worn and round. ● Wicks are frayed and coming out. <p style="text-align: right;">SEM396A</p>	<ul style="list-style-type: none"> ● Improper installation of belt ● Malfunctioning crankshaft pulley plate/ timing belt plate
Teeth are worn.	 <p style="text-align: center;">Rotating direction</p> <ul style="list-style-type: none"> ● Canvas on tooth face is worn down. ● Canvas on tooth is fluffy, rubber layer is worn down and faded white, or weft is worn down and invisible. <p style="text-align: right;">SEM397A</p>	<ul style="list-style-type: none"> ● Poor belt cover sealing ● Coolant leakage at water pump ● Camshaft not functioning properly ● Distributor not functioning properly ● Excessive belt tension
Oil/Coolant or water is stuck to belt.		<ul style="list-style-type: none"> ● Poor oil sealing of each oil seal ● Coolant leakage at water pump ● Poor belt cover sealing

Inspection (Cont'd)

BELT TENSIONER AND TENSIONER SPRING

1. Check belt tensioner for smooth turning.
2. Check condition of tensioner spring.

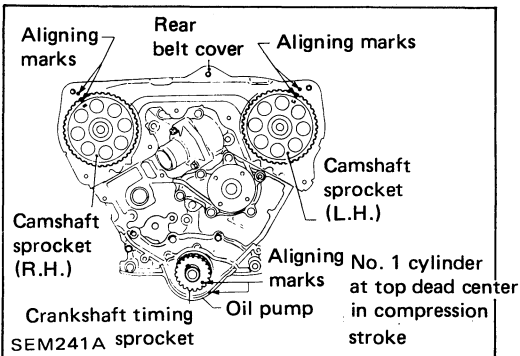
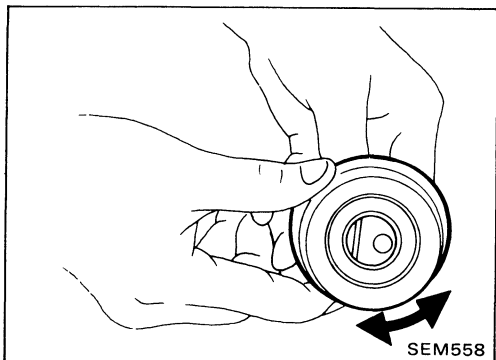

Installation

1. Confirm that No. 1 cylinder is set at T.D.C. on its compression stroke.

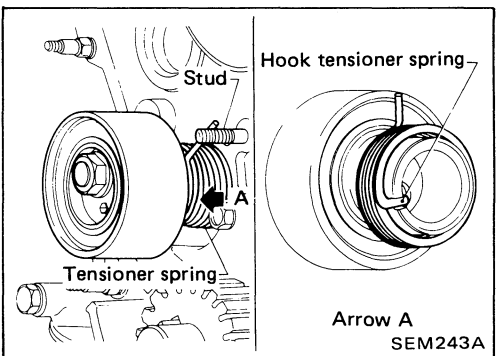

2. Install tensioner and tensioner spring.
If stud is once removed, apply locking sealant to threads of stud before installing.

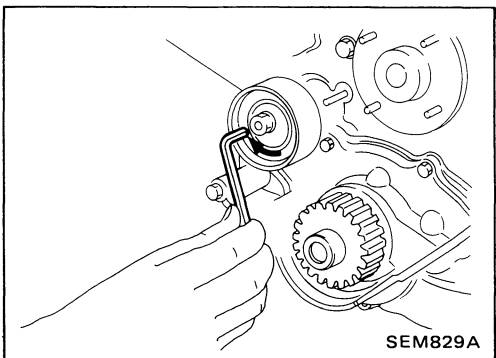

3. Turn tensioner fully clockwise with hexagon wrench, and temporarily tighten lock nut.

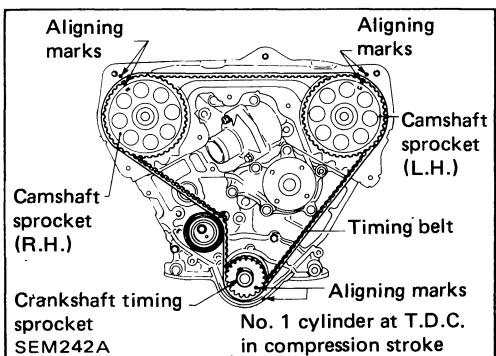

4. Set timing belt.
 - (1) **Align white lines on timing belt with punchmarks on camshaft sprockets and crankshaft sprocket.**
 - (2) **Point arrow on timing belt toward front belt cover.**
- Number of teeth (reference):**

Number of timing belt teeth		133
Number of teeth between timing marks	Between L.H. and R.H. camshaft sprockets	40
	Between L.H. camshaft sprocket and crankshaft timing sprocket	43

Installation (Cont'd)

- Loosen tensioner lock nut, keeping tensioner steady with a hexagon wrench.

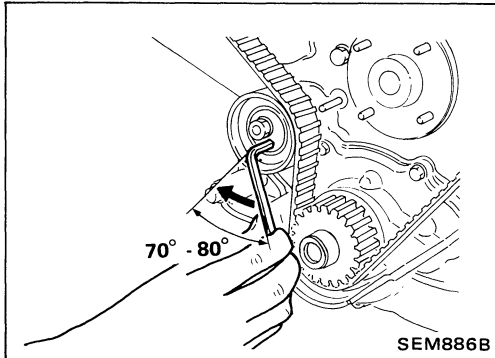

- Turn tensioner 70 to 80 degrees clockwise with hexagon wrench, and temporarily tighten lock nut.
- Turn crankshaft clockwise 2 or 3 times, then slowly set No. 1 cylinder at T.D.C. on its compression stroke.

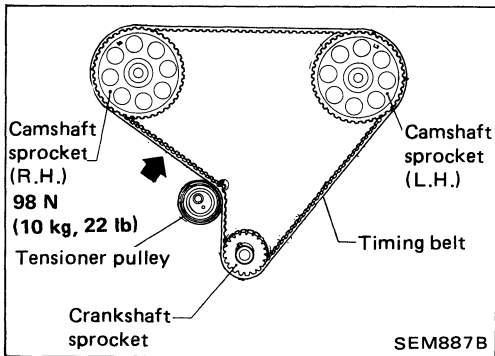

- Push middle of timing belt between R.H. camshaft sprocket and tensioner pulley with force of 98 N (10 kg, 22 lb).
- Loosen tensioner lock nut, keeping tensioner steady with a hexagon wrench.

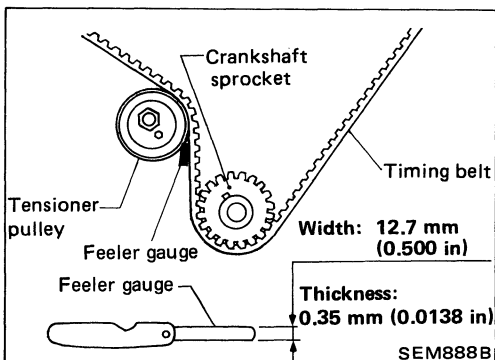

- Set feeler gauge as shown in the figure which is 0.35 mm (0.0138 in) thick and 12.7 mm (0.500 in) wide.

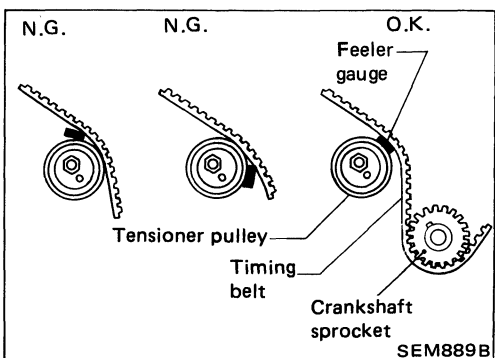

- Turn crankshaft clockwise, and set feeler gauge as shown in the figure.
 - Timing belt will move about 2.5 teeth.
- Tighten tensioner lock nut, keeping tensioner steady with a hexagon wrench.

Installation (Cont'd)

13. Turn crankshaft clockwise or counterclockwise, and remove feeler gauge.
14. Turn crankshaft clockwise 2 or 3 times, then slowly set No. 1 cylinder at T.D.C. on its compression stroke.

15. Install lower and upper belt covers.

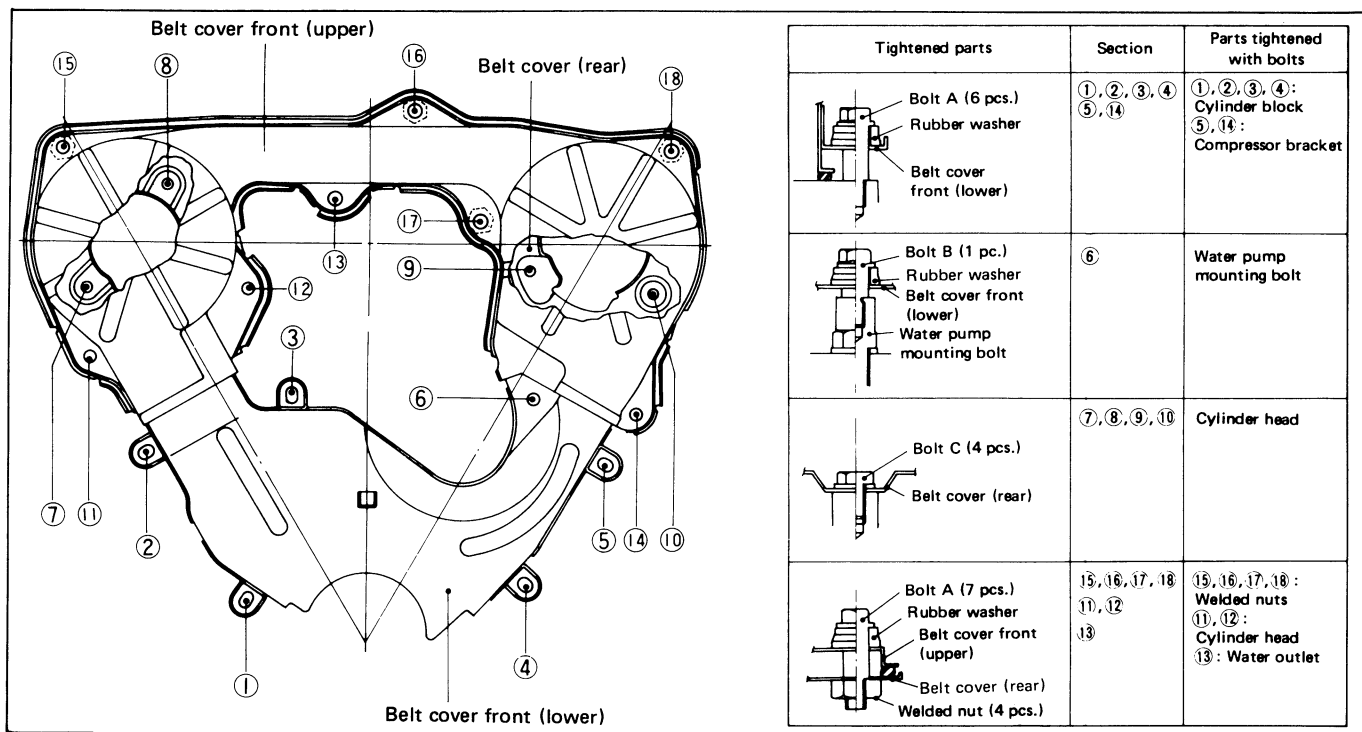

SEM248A

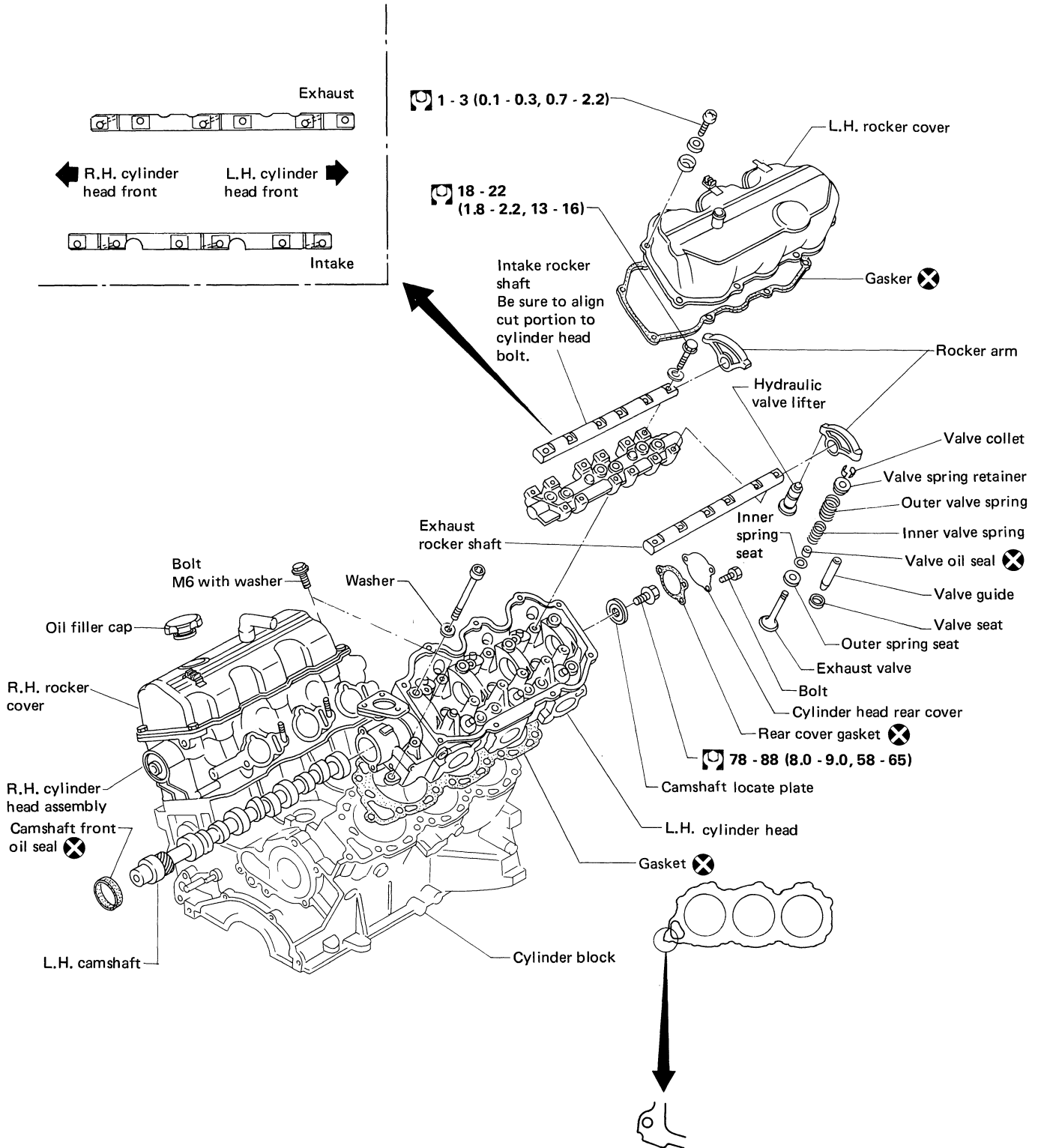

: N-m (kg-m, ft-lb)

SEM910B

CAUTION:

- When installing sliding parts such as rocker arms, camshaft and oil seal, be sure to apply new engine oil on their sliding surfaces.
- When tightening cylinder head bolts and rocker shaft bolts, apply new engine oil to the thread portions and seat surfaces of bolts.

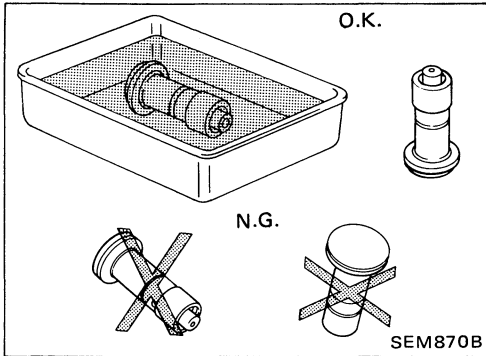

- If a hydraulic valve lifter is kept on its side, there is a risk of air entering it. After removal, always set hydraulic valve lifter straight up, or when laying it on its side, have it soak in new engine oil.
- Do not disassemble hydraulic valve lifter.
- Attach tags to valve lifters so as not to mix them up.

Removal

1. Remove timing belt.
Refer to "Removal" of TIMING BELT.
2. Drain coolant by removing drain plug on left side of cylinder block.

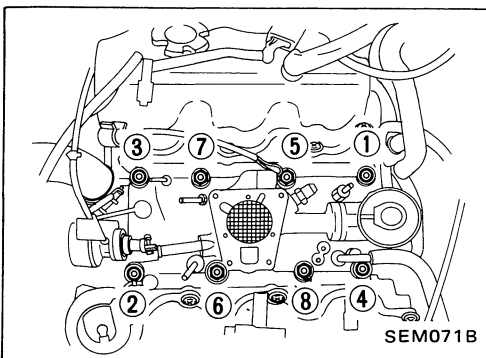

3. Remove air cleaner and remove intake manifold with injection body.
Before removing intake manifold, be sure to drain coolant removing drain plug on cylinder block.

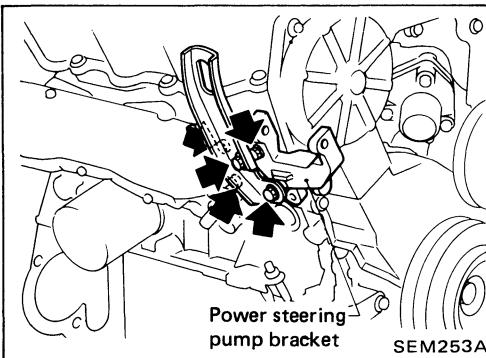

4. Remove power steering pump bracket.

Removal (Cont'd)

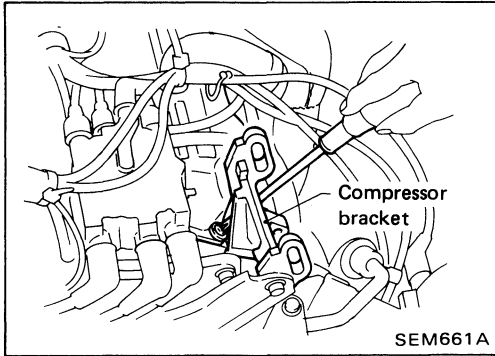

5. Remove camshaft pulleys and rear timing cover securing bolts.
6. Remove compressor and rocker covers.

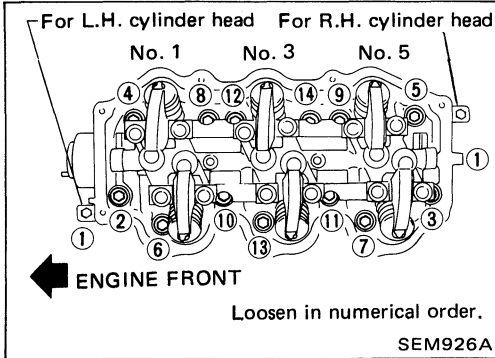

7. Remove cylinder head with exhaust manifold.
 - Head warpage or cracking could result from removing in incorrect order.
 - Cylinder head bolts should be loosened in two or three steps.

Disassembly

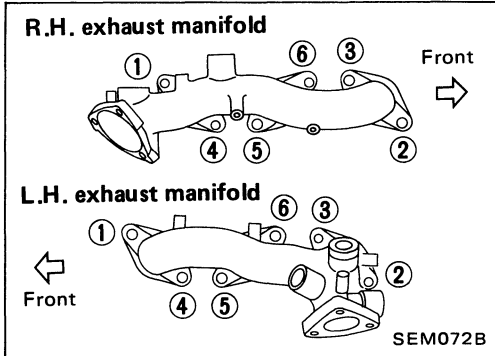

1. Remove exhaust manifolds from cylinder head.

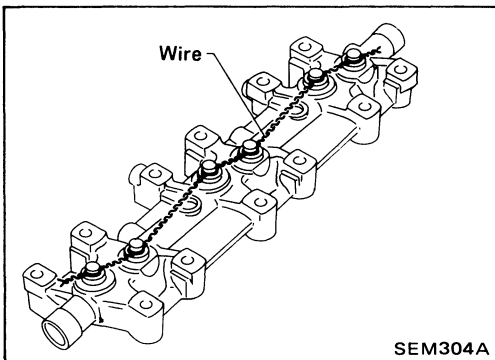

2. Remove rocker shafts with rocker arms.
 - Bolts should be loosened in two or three steps.
3. Remove hydraulic valve lifters and lifter guide.
 - Hold hydraulic valve lifters with wire so that they will not drop from lifter guide.

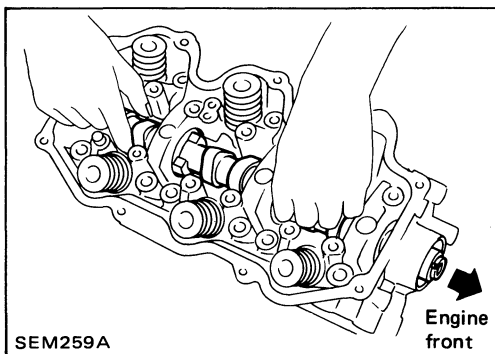

4. Remove oil seal and camshaft.
5. Remove valve components with Tool.
 - Tool: KV10110600 (J33986)
6. Remove valve oil seals.

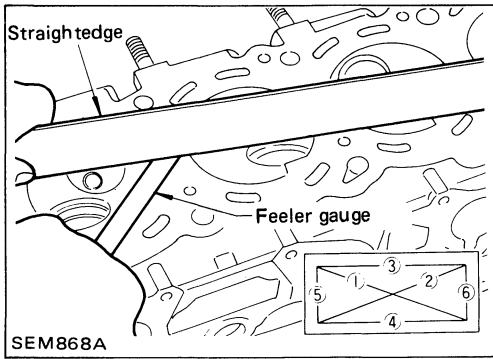

Inspection

CYLINDER HEAD DISTORTION

Head surface flatness:

Less than 0.1 mm (0.004 in)

If beyond the specified limit, replace it or resurface it.

Resurfacing limit:

The resurfacing limit of cylinder head is determined by the cylinder block resurfacing in an engine.

Amount of cylinder head resurfacing is "A"

Amount of cylinder block resurfacing is "B"

The maximum limit is as follows:

A + B = 0.2 mm (0.008 in)

After resurfacing the cylinder head, check that camshaft rotates freely by hand. If resistance is felt, the cylinder head must be replaced.

Nominal cylinder head height:

106.8 - 107.2 mm (4.205 - 4.220 in)

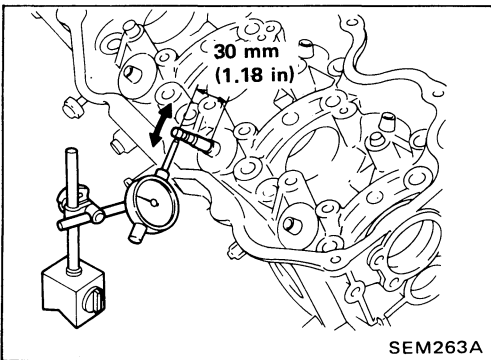

VALVE GUIDE CLEARANCE

1. Measure valve deflection in a parallel direction with rocker arm. (Valve and valve guide mostly wear in this direction.)

Valve deflection limit (Dial gauge reading):

0.20 mm (0.0079 in)

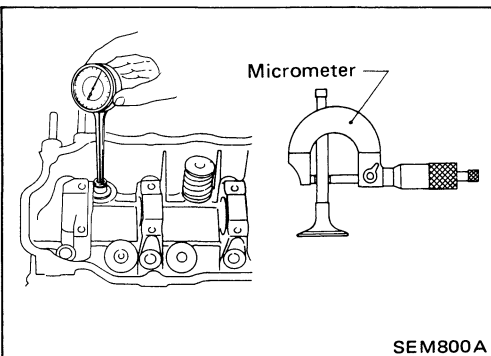

2. If it exceeds the limit, check valve to valve guide clearance.
 (1) Measure valve stem diameter "d" and valve guide inner diameter.

(2) Check that clearance is within the specification.

Valve to valve guide clearance limit:

0.10 mm (0.0039 in)

(3) If it exceeds the limit, replace valve or valve guide.

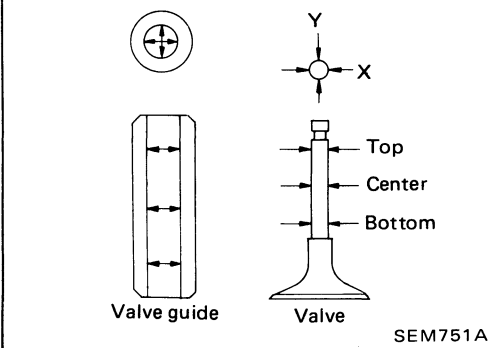

Inspection (Cont'd)

VALVE GUIDE REPLACEMENT

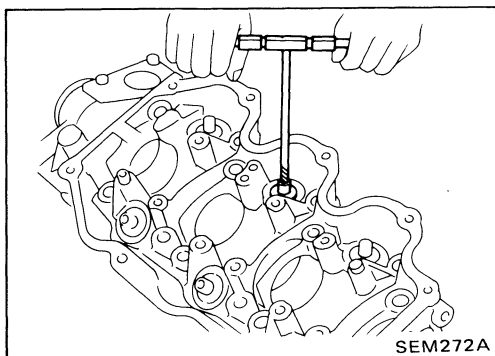
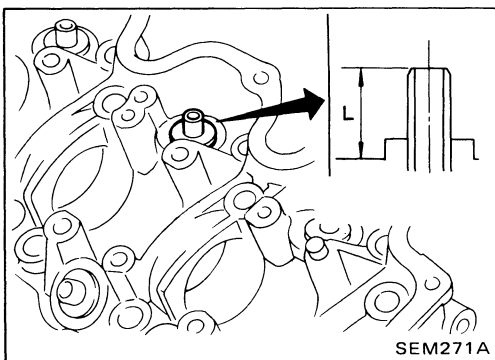
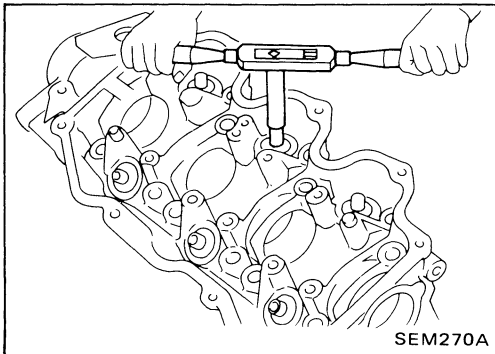
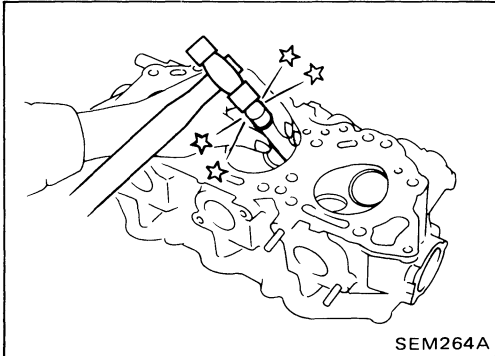
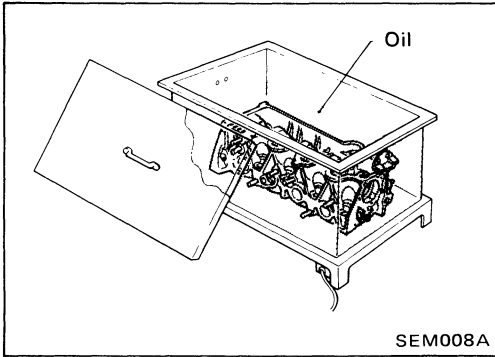

1. To remove valve guide, heat cylinder head to 150 to 160°C (302 to 320°F).

2. Drive out valve guide with a press [under a 20 kN (2 ton, 2.2 US ton, 2.0 Imp ton) pressure] or hammer and suitable tool.

3. Ream cylinder head valve guide hole.

**Valve guide hole diameter
(for service parts):**

Intake

11.175 - 11.196 mm (0.4400 - 0.4408 in)

Exhaust

12.175 - 12.196 mm (0.4793 - 0.4802 in)

4. Heat cylinder head to 150 to 160°C (302 to 320°F) and press service valve guide onto cylinder head.

Tapping length "L":

13.2 - 13.4 mm (0.520 - 0.528 in)

5. Ream valve guide.

Finished size:

Intake

7.000 - 7.018 mm (0.2756 - 0.2763 in)

Exhaust

8.000 - 8.018 mm (0.3150 - 0.3157 in)

Inspection (Con'd)

VALVE SEATS

Check valve seats for any evidence of pitting at valve contact surface, and reseat or replace if it has worn out excessively.

- **Before repairing valve seats, check valve and valve guide for wear. If they have worn, replace them. Then correct valve seat.**
- **Cut with both hands to uniform the cutting surface.**

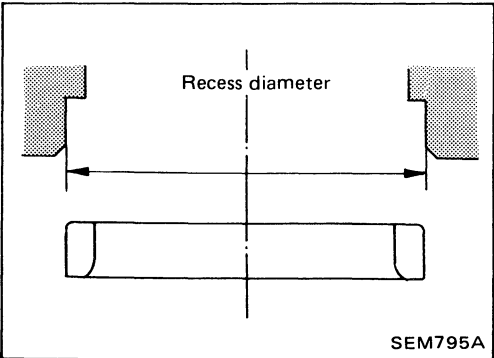
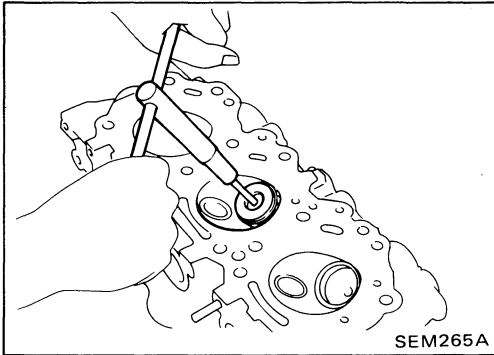

REPLACING VALVE SEAT FOR SERVICE PARTS

1. Bore out old seat until it collapses. The machine depth stop should be set so that boring cannot continue beyond the bottom face of the seat recess in cylinder head.
2. Ream cylinder head recess.

Reaming bore for service valve seat

[Oversize 0.5 mm (0.020 in)]:

Intake

44.500 - 44.516 mm (1.7520 - 1.7526 in)

Exhaust

37.500 - 37.516 mm (1.4764 - 1.4770 in)

Reaming should be done to the concentric circles to valve guide center so that valve seat will have the correct fit.

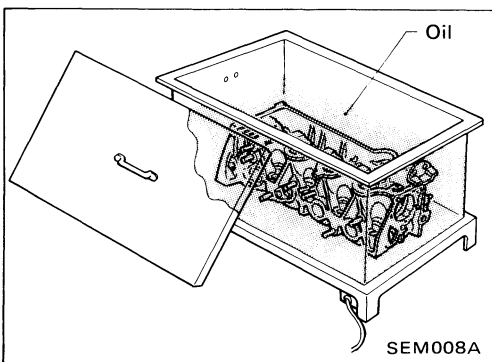

3. Heat cylinder head to 150 to 160°C (302 to 320°F).
4. Press fit valve seat until it seats on the bottom.

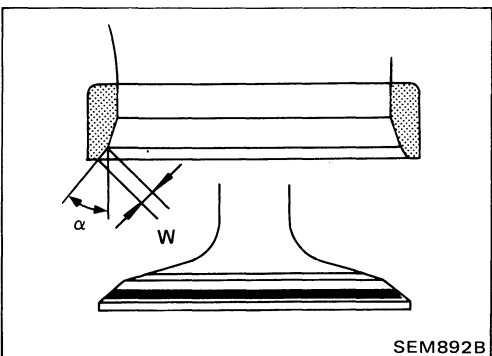

5. Cut or grind valve seat using suitable tool at the specified dimensions as shown in S.D.S.
6. After cutting, lap valve seat with an abrasive compound.
7. Check valve seating condition.

		Intake	Exhaust
Seat face angle " α "	degree	45	45
Contacting width "W"	mm (in)	1.75 (0.0689)	1.7 (0.067)

Inspection (Cont'd)
CAMSHAFT VISUAL CHECK

Check camshaft for scratches, seizure and wear.

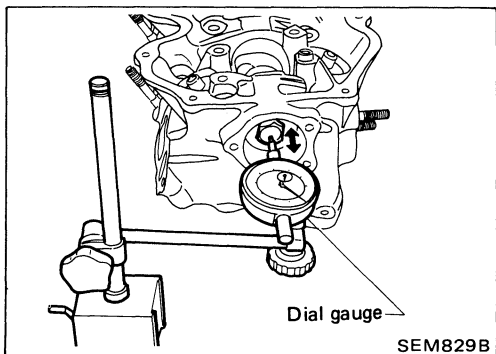

CAMSHAFT END PLAY

1. Install camshaft and locate plate in cylinder head.
2. Measure camshaft end play.

Camshaft end play:

Standard 0.03 - 0.06 mm (0.0012 - 0.0024 in)

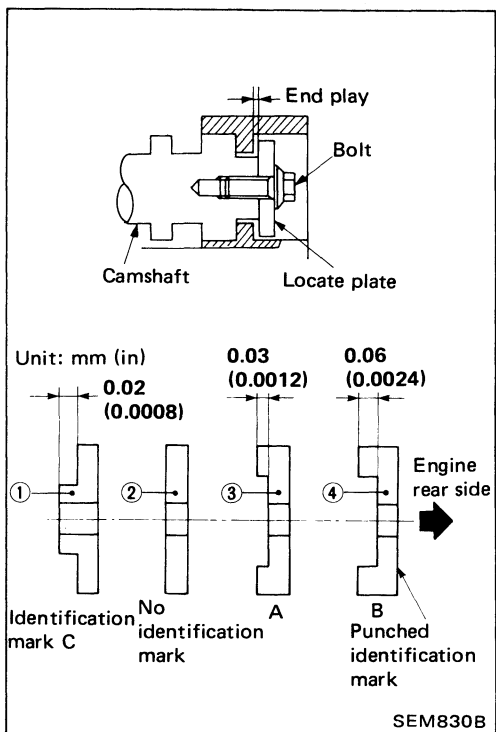

3. If it is out of the specified range, select thickness of camshaft locate plate to obtain the standard specified end play.

Example:

When camshaft end play is 0.08 mm (0.0031 in) with shim ②, replace shim ② with shim ③ to set the end play at 0.05 mm (0.0020 in).

CAMSHAFT JOURNAL CLEARANCE

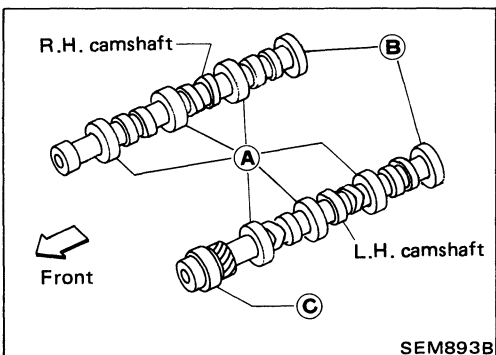

Inspection (Cont'd)

1. Measure the inner diameter of camshaft bearing.

Standard inner diameter:

- Ⓐ 47.000 - 47.025 mm (1.8504 - 1.8514 in)
- Ⓑ 42.500 - 42.525 mm (1.6732 - 1.6742 in)
- Ⓒ 48.000 - 48.025 mm (1.8898 - 1.8907 in)

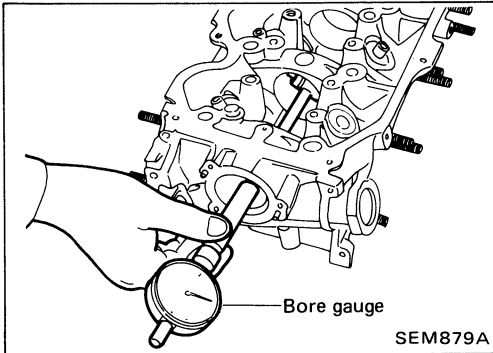

2. Measure the outer diameter of camshaft journal.

Standard outer diameter:

- Ⓐ 46.920 - 46.940 mm (1.8472 - 1.8480 in)
- Ⓑ 42.420 - 42.440 mm (1.6701 - 1.6709 in)
- Ⓒ 47.920 - 47.940 mm (1.8866 - 1.8874 in)

3. If the clearance exceeds the limit, replace camshaft and/or cylinder head.

Camshaft journal clearance limit:

0.15 mm (0.0059 in)

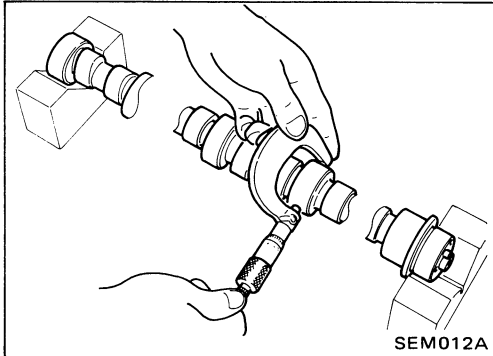
**CAMSHAFT RUNOUT**

1. Measure camshaft runout at the center journal.

Runout (Total indicator reading):

Limit 0.10 mm (0.0039 in)

2. If it exceeds the limit, replace camshaft.

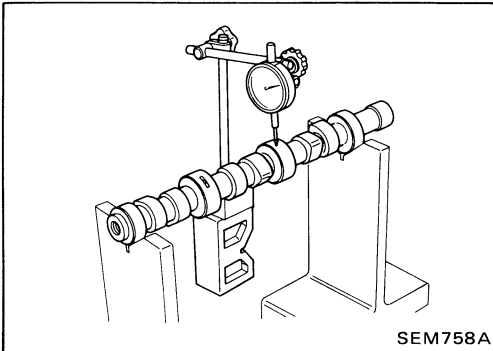
**CAMSHAFT CAM HEIGHT**

1. Measure camshaft cam height.

Standard cam height:

39.537 - 39.727 mm (1.5566 - 1.5641 in)

Cam wear limit:

0.15 mm (0.0059 in)

2. If wear is beyond the limit, replace camshaft.

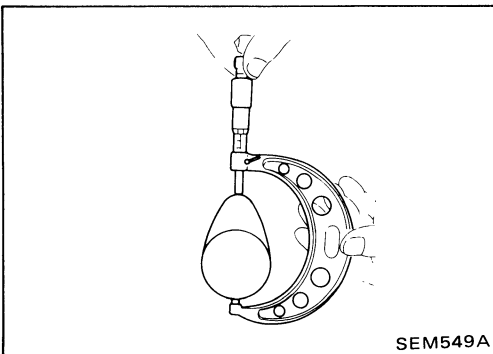
**CAMSHAFT SPROCKET RUNOUT**

1. Install sprocket on camshaft.
2. Measure camshaft sprocket runout.

Runout (Total indicator reading):

Limit 0.1 mm (0.004 in)

3. If it exceeds the limit, replace camshaft sprocket.

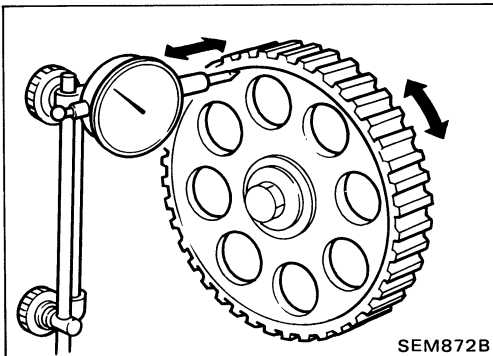

Inspection (Cont'd)**VALVE DIMENSIONS**

1. Check dimensions in each valve. For dimensions, refer to S.D.S.
2. When valve head has been worn down to 0.5 mm (0.020 in) in margin thickness, replace the valve.

Grinding allowance for valve stem tip is 0.2 mm (0.008 in) or less.

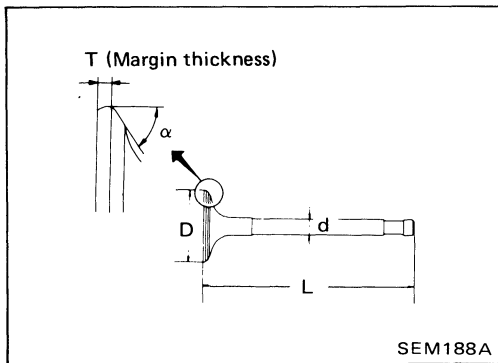

SEM188A

VALVE SPRING SQUARENESS

1. Measure "S" dimension.

Out-of-square:**Outer**

Less than 2.2 mm (0.087 in)

Inner

Less than 1.9 mm (0.075 in)

2. If it exceeds the limit, replace spring.

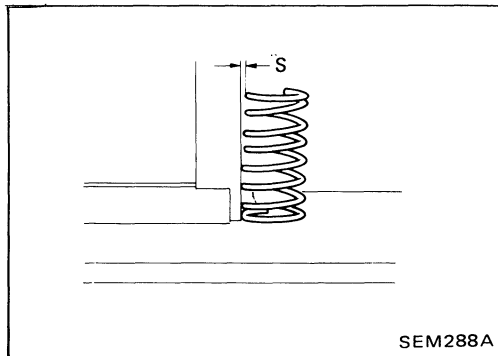

SEM288A

VALVE SPRING PRESSURE HEIGHT

Check valve spring pressure height.

Pressure height: mm/N (mm/kg, in/lb)

Standard

Outer 30.0/523.7 (30.0/53.4, 1.181/117.7)

Inner 25.0/255.0 (25.0/26.0, 0.984/57.3)

Limit

Outer 30.0/462.9 (30.0/47.2, 1.181/104.1)

Inner 25.0/225.6 (25.0/23.0, 0.984/50.7)

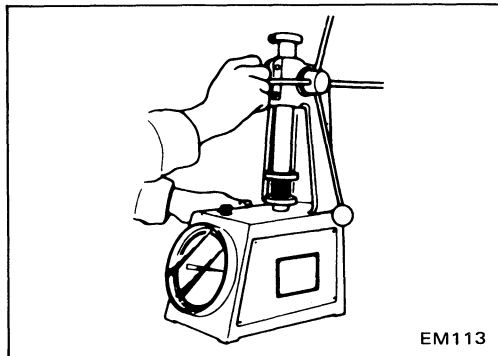

EM113

HYDRAULIC VALVE LIFTER

1. Check contact and sliding surfaces for wear or scratches.

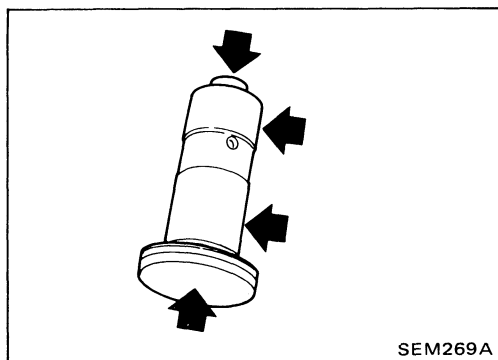

SEM269A

2. Check diameter of a valve lifter.

Outer diameter:

15.947 - 15.957 mm (0.6278 - 0.6282 in)

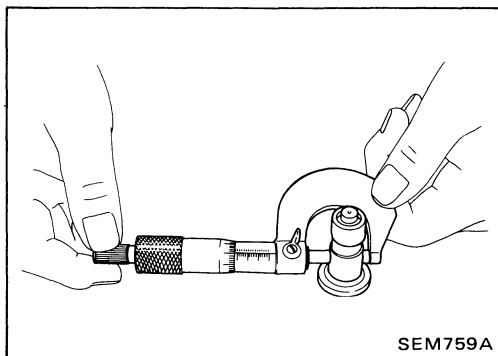

SEM759A

Inspection (Cont'd)

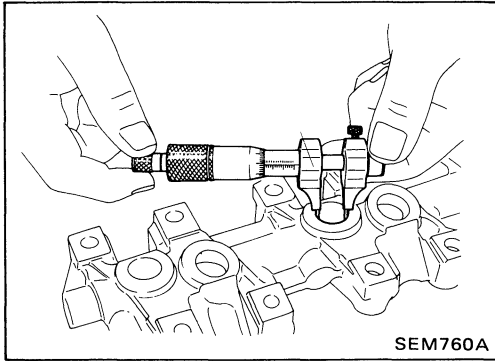

3. Check valve lifter guide inner diameter.

Inner diameter:

16.000 - 16.013 mm (0.6299 - 0.6304 in)

Standard clearance between valve lifter and lifter guide:

0.043 - 0.066 mm (0.0017 - 0.0026 in)

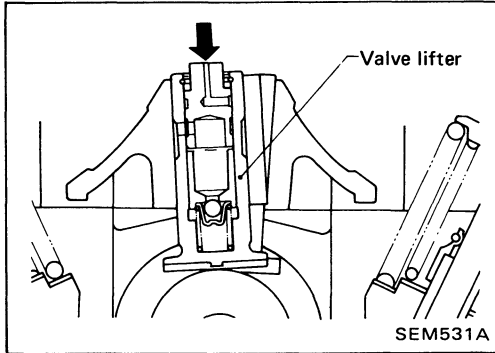

4. Check hydraulic valve lifter.

(1) Push plunger forcefully with your finger.

● **Be sure to check it with rocker arm in its free position (not on the lobe).**

(2) If valve lifter moves more than 1 mm (0.04 in), air may be inside of it.

(3) Bleed air off by running engine at 1,000 rpm under no-load for about 10 minutes.

(4) If hydraulic valve lifters are still noisy, replace them and bleed air off again in the same manner as in step (3).

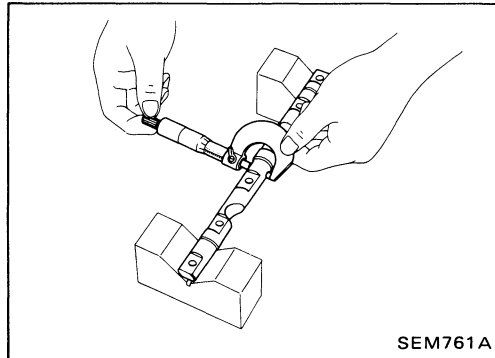

ROCKER SHAFT AND ROCKER ARM

1. Check rocker shafts for scratches, seizure and wear.

2. Check outer diameter of rocker shaft.

Diameter mm (in):

17.979 - 18.000 (0.7078 - 0.7087)

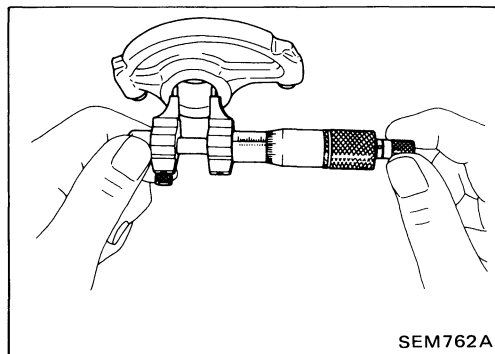

3. Check inner diameter of rocker arm.

Diameter mm (in):

18.007 - 18.028 (0.7089 - 0.7098)

Rocker arm to shaft clearance mm (in):

0.007 - 0.049 (0.0003 - 0.0019)

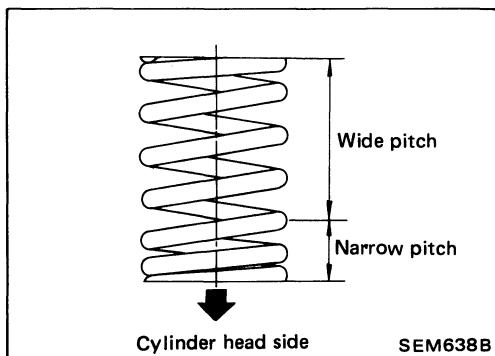

Assembly

1. Install valve component parts.

● **Always use new valve oil seal. Refer to OIL SEAL REPLACEMENT.**

● **Before installing valve oil seal, install inner valve spring seat.**

● **Install outer valve spring (uneven pitch type) with its narrow pitch side toward cylinder head side.**

CYLINDER HEAD

Assembly (Cont'd)

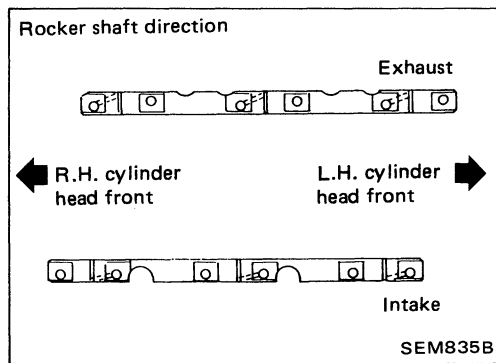
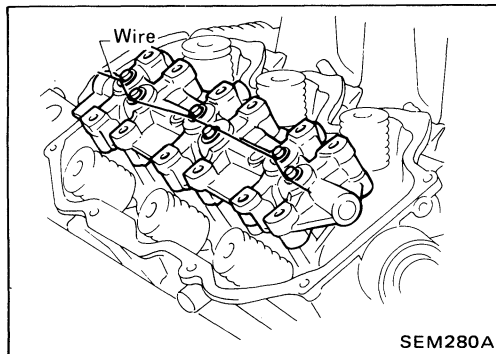
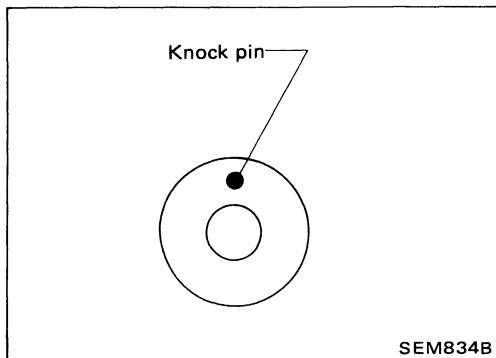

2. Install camshafts, locate plates and cylinder head rear covers.

- Set knock pin of camshaft at the top.

3. Install valve lifters into valve lifter guide.

- Assemble valve lifters to their original position and hold all valve lifters with wire to prevent lifters from falling off.
- After installing them, remove the wire.

4. Install rocker shafts with rocker arms.

- Tighten bolts gradually in two or three stages.
- Before tightening, be sure to set camshaft lobe at the position where lobe is not lifted.

(1) Set No. 1 piston at T.D.C. on its compression stroke and tighten rocker shaft bolts for No. 2, No. 4 and No. 6 cylinders.

(2) Set No. 4 piston at T.D.C. on its compression stroke and tighten rocker shaft bolts for No. 1, No. 3 and No. 5 cylinders.

5. Install exhaust manifold to cylinder head in reverse order of removal.

Installation

1. Set No. 1 cylinder at T.D.C. on its compression stroke as follows:

- (1) Align crankshaft sprocket aligning mark with mark on oil pump body.
- (2) Confirm that knock pin on camshaft is set at the top.

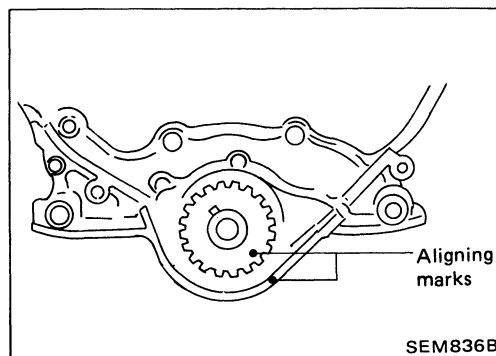

Installation (Cont'd)

2. Install cylinder head with new gasket.

- Be sure to install washers between bolts and cylinder head.
- Do not rotate crankshaft and camshaft separately, or valves will hit piston heads.

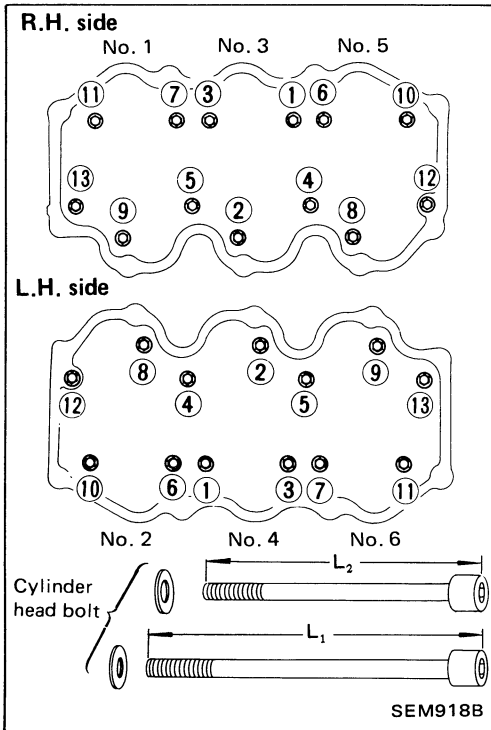
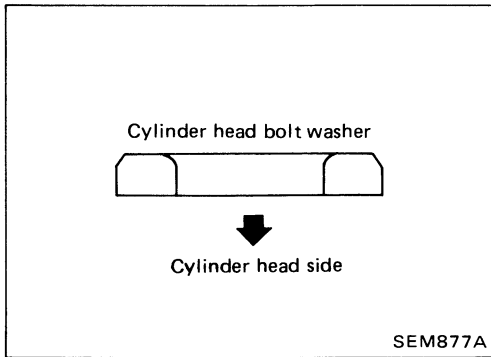

3. Tighten cylinder head bolts in numerical order using ST10120000 (J24239-01).

- **Tightening procedure.**
- (1) Tighten all bolts to 29 N·m (3.0 kg-m, 22 ft-lb).
- (2) Tighten all bolts to 59 N·m (6.0 kg-m, 43 ft-lb).
- (3) Loosen all bolts completely.
- (4) Tighten all bolts to 29 N·m (3.0 kg-m, 22 ft-lb).
- (5) Tighten all bolts to 54 to 64 N·m (5.5 to 6.5 kg-m, 40 to 47 ft-lb) or if you have an angle wrench, turn all bolts 60 to 65 degrees clockwise.
- Bolts for ④, ⑤, ⑫ and ⑬ are longer than the others.
 - L₁: 127 mm (5.00 in) for ④, ⑤, ⑫ and ⑬
 - L₂: 106 mm (4.17 in) for others

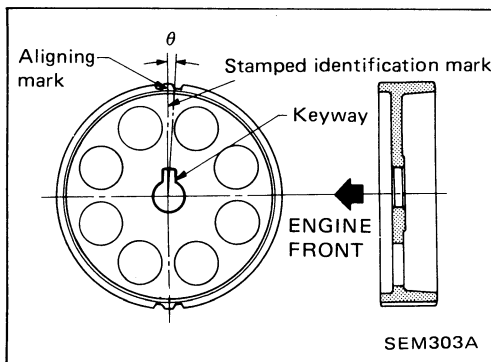

4. Install rear belt cover and camshaft sprocket.

- R.H. camshaft sprocket and L.H. camshaft sprocket are different parts. Be sure to install them in the correct positions.

	Identification mark	θ
R.H. camshaft sprocket	R3	0°53'
L.H. camshaft sprocket	L3	-3°27'

5. Install timing belt and adjust belt tension.

Refer to "Installation" of TIMING BELT.

Installation (Cont'd)

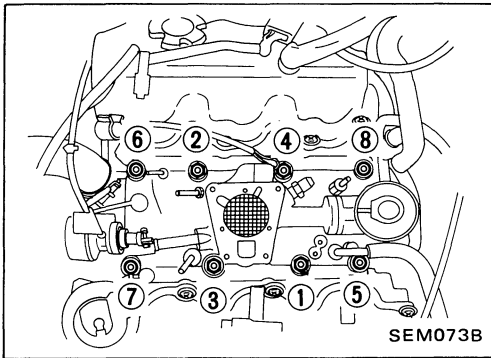

6. Install intake manifold.
 ● Tighten manifold bolts and nuts in two or three stages in reverse order of removal.

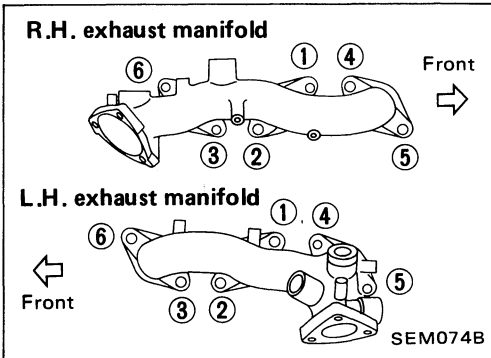

7. Install exhaust manifolds and connecting tube.
 ● Tighten manifold bolts in reverse order of removal.

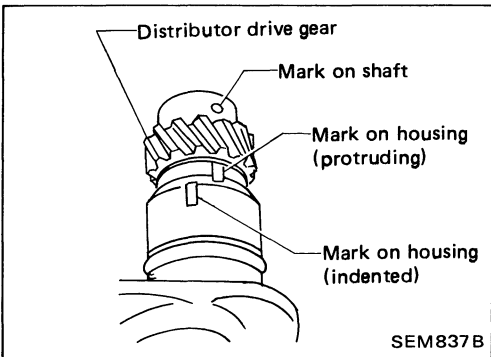

8. Install distributor.
 (1) Align mark on shaft with protrusive mark on housing.

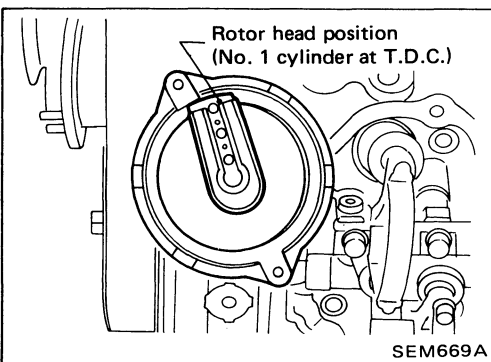

- (2) After installing, confirm that distributor rotor head is set as shown in the figure.

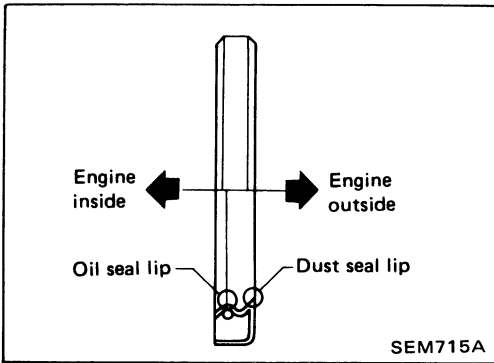

OIL SEAL INSTALLING DIRECTION

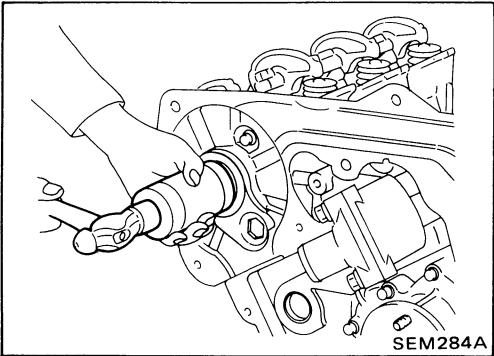

CAMSHAFT OIL SEAL

1. Remove timing belt.
2. Remove camshaft sprocket.
3. Remove camshaft oil seal.

Be careful not to scratch camshaft.

4. Apply engine oil to camshaft oil seal and install it using suitable tool.

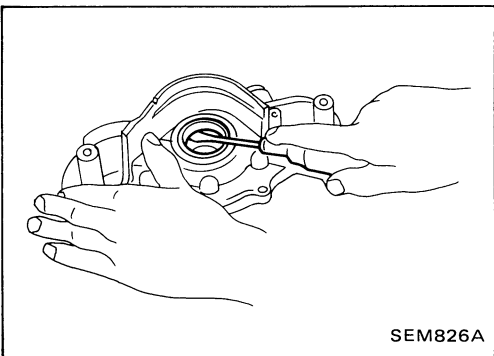

FRONT OIL SEAL

1. Remove timing belt and crankshaft sprocket.
2. Remove oil pump assembly.
3. Remove front oil seal from oil pump body.

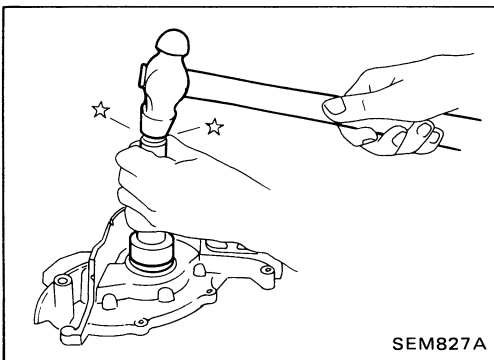

4. Apply engine oil to new oil seal and install it using suitable tool.

REAR OIL SEAL

1. Remove flywheel/drive plate.
2. Remove rear oil seal retainer.
3. Remove rear oil seal from retainer.

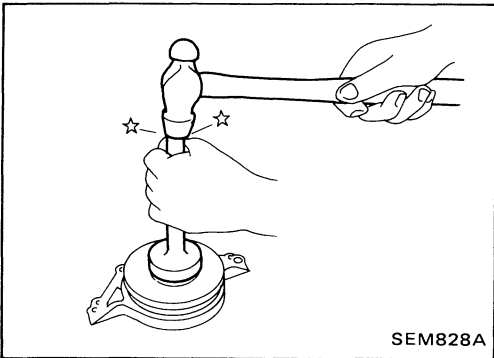

4. Apply engine oil to oil seal and install it using suitable tool.
5. Install rear oil seal retainer with a new gasket to cylinder block.

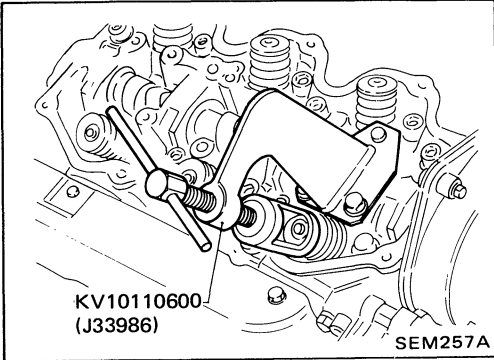

VALVE OIL SEAL

1. Remove rocker cover.
2. Remove rocker shaft assembly and valve lifters with valve lifter guide.
3. Remove valve springs and valve oil seal.
 - Piston concerned should be set at T.D.C. to prevent valve from falling off.
 - When removing intake side valve oil seal, use Tool.

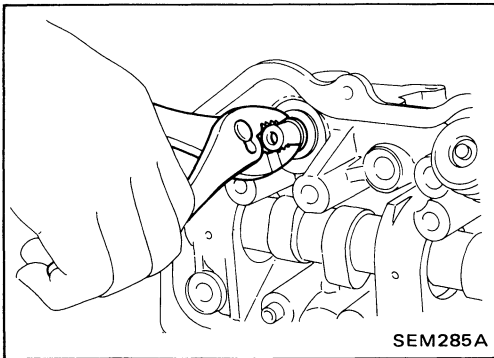

- When removing exhaust side valve oil seal, pull it out with pliers.

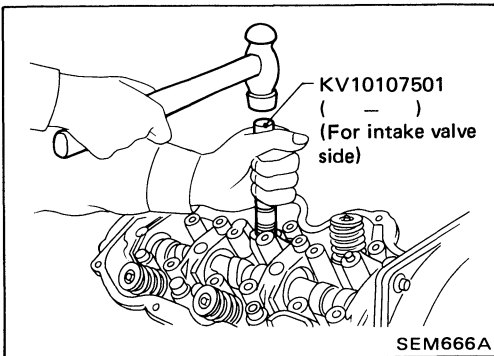

4. Apply engine oil to new valve oil seal and install it.
 - Before installing valve oil seal, install inner valve spring seat.
 - When installing intake side valve oil seal, use special service tool.

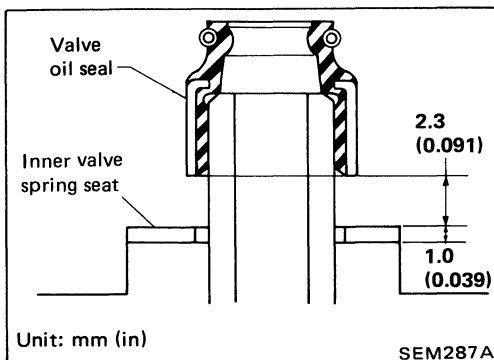

- When installing exhaust side valve oil seal, set it by hand.

For 4WD model

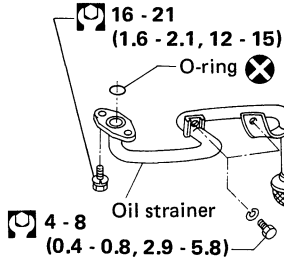

For 4WD model

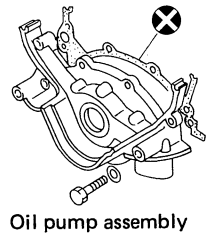

Oil pump assembly

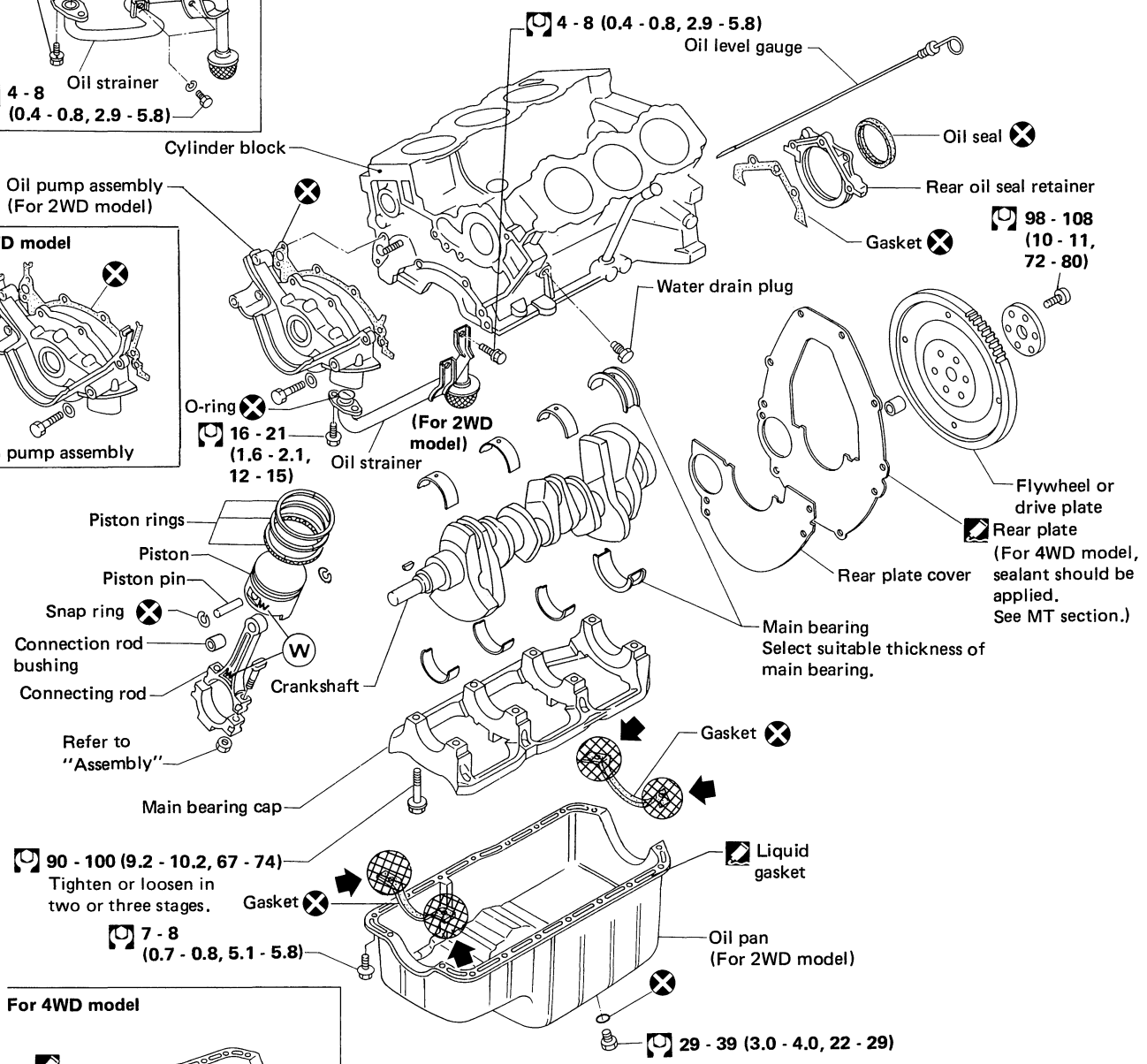

For 4WD model

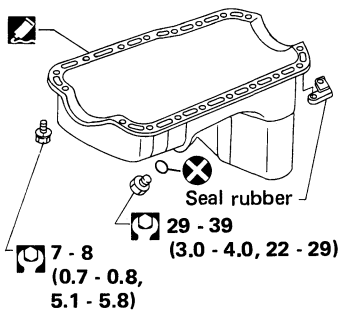

⬅ : Apply sealant.
Ⓜ : N·m (kg·m, ft·lb)

CAUTION:

- When installing sliding parts such as bearings and pistons, be sure to apply engine oil on the sliding surfaces.
- Place the removed parts such as bearings and bearing caps in their proper order and direction.
- When tightening connecting rod bolts and main bearing cap bolts, apply engine oil to the thread portion of bolts and seating surface of nuts.

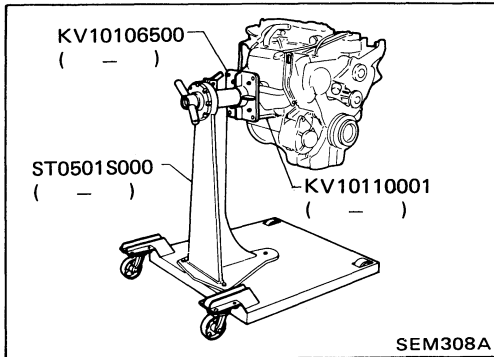

Disassembly

PISTON AND CRANKSHAFT

1. Place engine on work stand.
2. Remove timing belt.
3. Drain coolant and remove water pump.
4. Drain oil.
5. Remove oil pan and oil pump.
6. Remove cylinder head.
7. Remove pistons.
 - When disassembling piston and connecting rod, remove snap ring first, then heat piston to 60 to 70°C (140 to 158°F) or use piston pin press stand at room temperature.
8. Remove bearing cap and crankshaft.

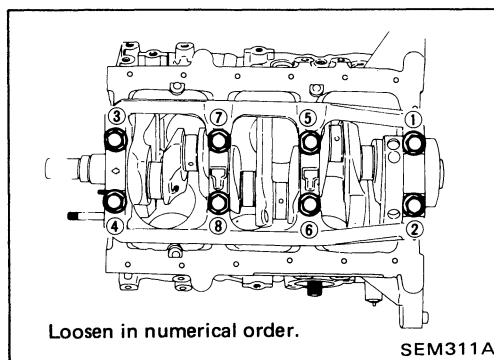
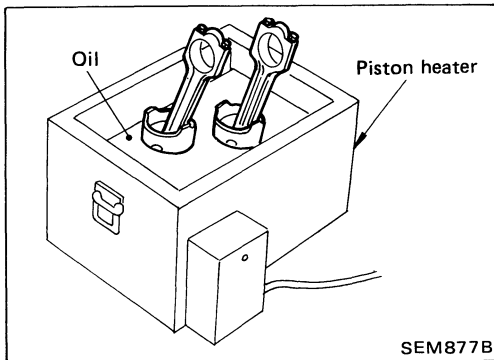

Inspection

PISTON AND PISTON PIN CLEARANCE

1. Measure inner diameter of piston pin hole "dp".
 - Standard diameter "dp":**
 - 20.969 - 20.981 mm (0.8255 - 0.8260 in)**

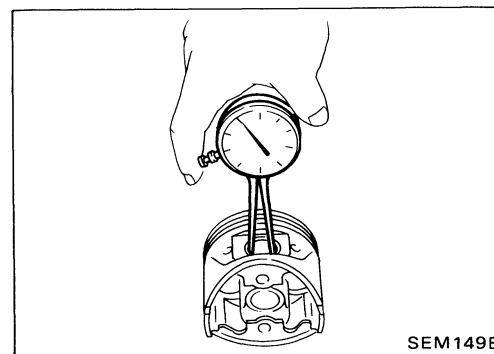

Inspection (Cont'd)

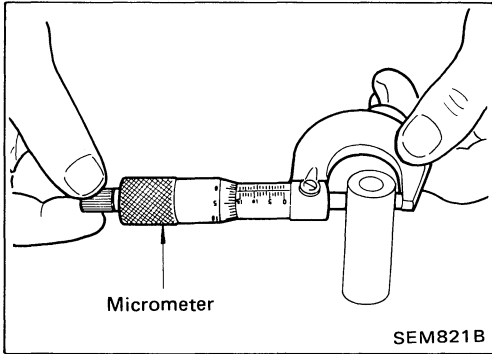

2. Measure outer diameter of piston pin "Dp".

Standard diameter "Dp":

20.971 - 20.983 mm (0.8256 - 0.8261 in)

3. Calculate piston pin clearance.

$$dp - Dp = -0.008 \text{ to } 0.004 \text{ mm } (-0.0003 \text{ to } 0.0002 \text{ in})$$

If it exceeds the limit, replace piston assembly with pin.

PISTON RING SIDE CLEARANCE

Side clearance:

Top ring

0.040 - 0.073 mm (0.0016 - 0.0029 in)

2nd ring

0.030 - 0.063 mm (0.0012 - 0.0025 in)

Oil ring

0.015 - 0.190 mm (0.0006 - 0.0075 in)

Max. limit of side clearance: 0.1 mm (0.004 in)

If out of specification, replace piston/piston pin assembly.

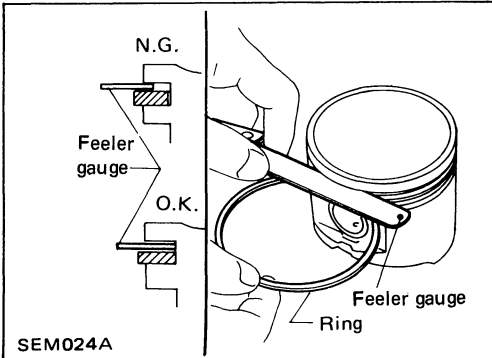

PISTON RING GAP

Standard ring gap:

Top ring

0.21 - 0.44 mm (0.0083 - 0.0173 in)

2nd ring

0.18 - 0.44 mm (0.0071 - 0.0173 in)

Oil ring

0.20 - 0.76 mm (0.0079 - 0.0299 in)

Max. limit of ring gap:

1.0 mm (0.039 in)

If out of specification, replace piston ring. If gap still exceeds the limit even with a new ring, rebore the cylinder and use oversized piston/piston ring assembly.

Refer to S.D.S.

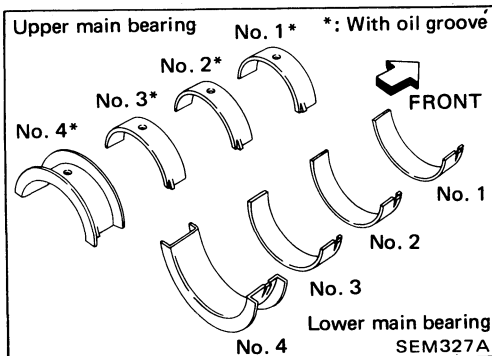
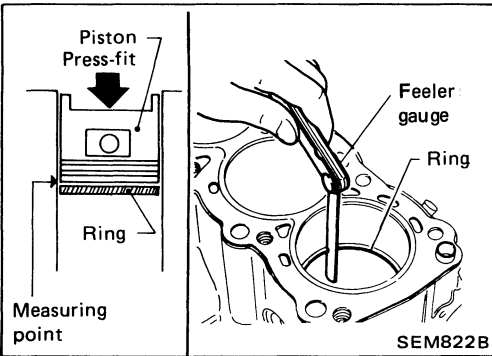

BEARING CLEARANCE

Method A (Using dial gauge & micrometer)

Main bearing

1. Set main bearings in their proper positions on cylinder block and main bearing cap.

Inspection (Cont'd)

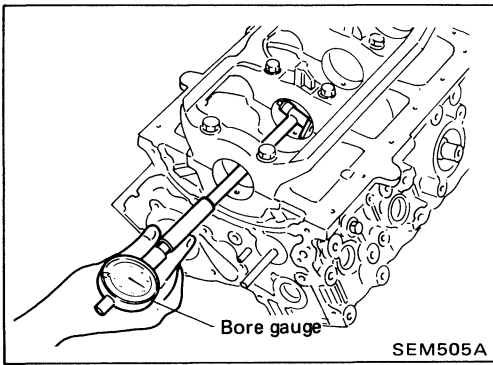

2. Install main bearing cap to cylinder block.
- Tighten all bolts in correct order in two or three stages.**
3. Measure inner diameter "A" of main journal.

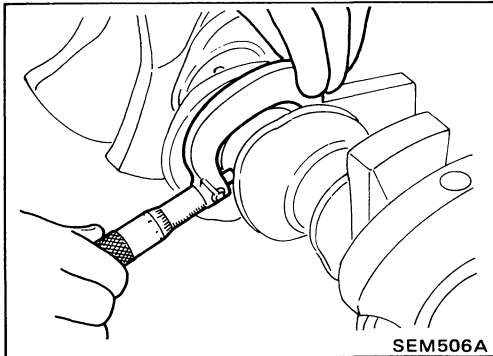

4. Measure outer diameter "Dm" of crankshaft main journal.
5. Calculate main bearing clearance.

$$\text{Main bearing clearance} = A - Dm$$

Standard: 0.028 - 0.055 mm (0.0011 - 0.0022 in)
Limit: 0.090 mm (0.0035 in)
6. If it exceeds the limit, replace the bearing.
7. If the clearance cannot be adjusted within the standard with any bearing, grind crankshaft journal and use undersized bearing.

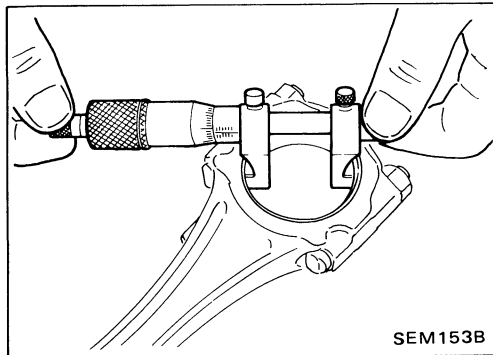

Connecting rod bearing (Big end)

1. Install connecting rod bearing to connecting rod and cap.
2. Install connecting rod cap to connecting rod.
- Tighten bolts to the specified torque.**
3. Measure inner diameter "C" of bearing.

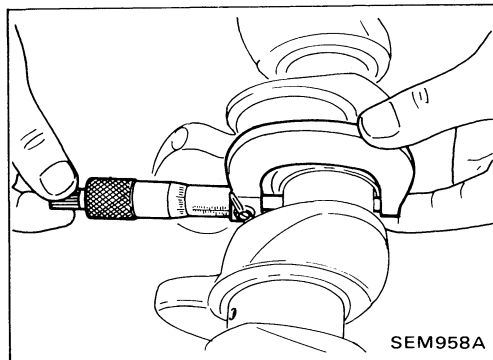

4. Measure outer diameter "Dp" of crankshaft pin journal.
5. Calculate connecting rod bearing clearance.

$$\text{Connecting rod bearing clearance} = C - Dp$$

Standard: 0.014 - 0.054 mm (0.0006 - 0.0021 in)
Limit: 0.090 mm (0.0035 in)
6. If it exceeds the limit, replace the bearing.
7. If the clearance cannot be adjusted within the standard with any bearing, grind crankshaft journal and use undersized bearing.

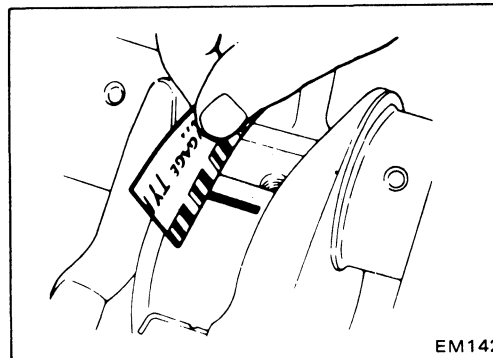

Method B (Using plastigage)

CAUTION:

- Do not turn crankshaft or connecting rod while the plastigage is being inserted.
- When bearing clearance exceeds the specified limit, ensure that the proper bearing has been installed. Then if excessive bearing clearance exists, use thicker main bearing or undersized bearing so that the specified bearing clearance is obtained.

Inspection (Cont'd)

Main bearing clearance:

Standard

0.028 - 0.055 mm (0.0011 - 0.0022 in)

Limit

0.090 mm (0.0035 in)

Connecting rod bearing clearance:

Standard

0.014 - 0.054 mm (0.0006 - 0.0021 in)

Limit

0.090 mm (0.0035 in)

CONNECTING ROD BUSHING CLEARANCE (Small end)

1. Measure inner diameter "C" of bushing.

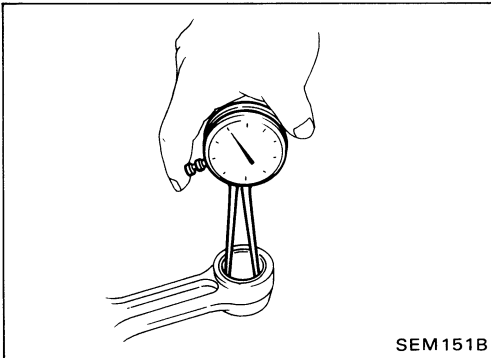

2. Measure outer diameter "Dp" of piston pin.

3. Calculate connecting rod bushing clearance.

$$C - Dp = 0.005 - 0.017 \text{ mm (0.0002 - 0.0007 in)}$$

If it exceeds the limit, replace connecting rod assembly and/or piston set with pin.

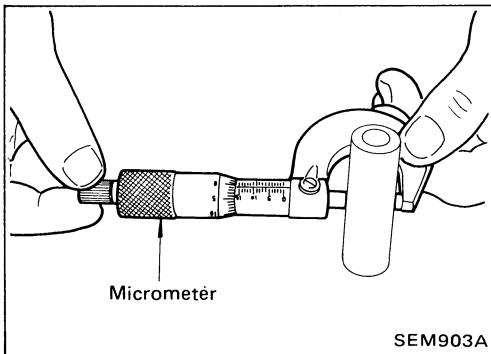

REPLACEMENT OF CONNECTING ROD SMALL END BUSHING

1. Drive in the small end bushing until it is flush with the end surface of the rod.

Be sure to align the oil holes.

2. After driving in the small end bushing, ream the bushing.

Small end bushing inside diameter:

Finished size

20.982 - 20.994 mm (0.8261 - 0.8265 in)

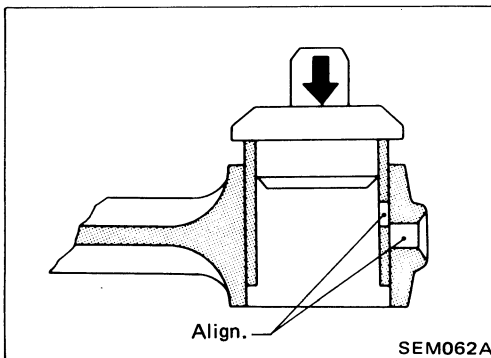

CONNECTING ROD BEND AND TORSION

Bend and torsion:

Limit 0.1 mm (0.004 in)

per 100 mm (3.94 in) length

If it exceeds the limit, replace connecting rod assembly.

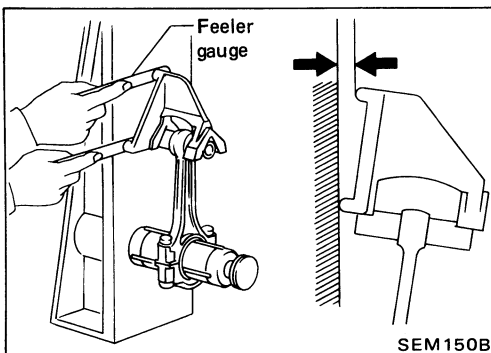

**Inspection (Cont'd)
CRANKSHAFT**

1. Check crankshaft journals for score, bias, wear or cracks.
2. With a micrometer, measure journals for taper and out-of-round.

Out-of-round (X-Y):

Less than 0.005 mm (0.0002 in)

Taper (A-B):

Less than 0.005 mm (0.0002 in)

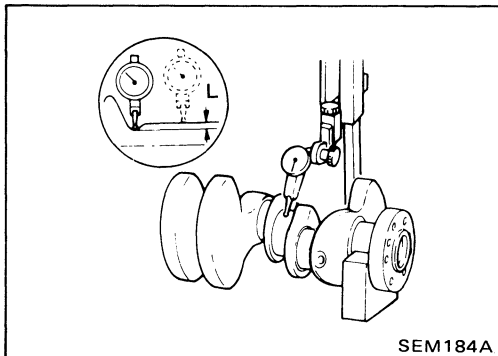
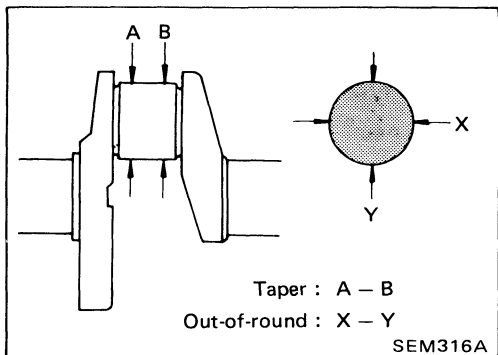

- a. When grinding crank pin and crank journal, measure "L" dimension in fillet roll. Make sure the measurements exceed the specified limit. If the measurements are within the specified limit, do not regrind.

L: More than 0.13 mm (0.0051 in)

- b. Do not grind off fillet roll.
- c. Refer to S.D.S. for grinding crankshaft and available service parts.

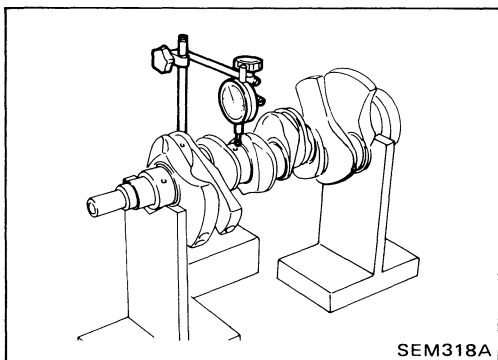

3. Measure crankshaft runout.

Runout T.I.R. (Total Indicator Reading):

Less than 0.10 mm (0.0039 in)

CYLINDER BLOCK DISTORTION AND WEAR

1. Clean upper face of cylinder block and measure the distortion.

Limit:

0.10 mm (0.0039 in)

2. If out of specification, resurface it. The resurfacing limit is determined by the cylinder head resurfacing in engine.

Amount of cylinder head resurfacing is "A"

Amount of cylinder block resurfacing is "B"

The maximum limit is as follows:

A + B = 0.2 mm (0.008 in)

Nominal cylinder block height from crankshaft center:

227.65 ± 0.05 mm (8.9626 ± 0.0020 in)

3. If necessary, replace cylinder block.

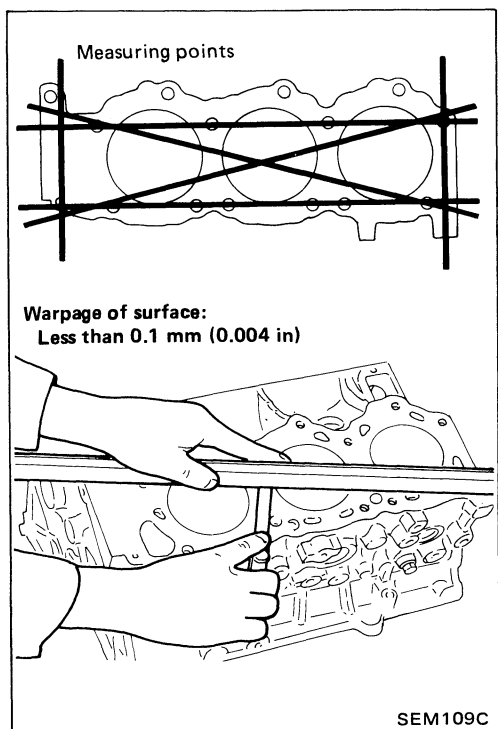

Inspection (Cont'd)
PISTON-TO-BORE CLEARANCE

- Using a bore gauge, measure cylinder bore for wear, out-of-round or taper.

Standard inner diameter:

87.00 - 87.05 mm (3.4252 - 3.4272 in)

Refer to S.D.S.

Out-of-round (X—Y):

Limit 0.015 mm (0.0006 in)

Taper (A-B-C):

Limit 0.015 mm (0.0006 in)

If it exceeds the limit, rebore all cylinders. Replace cylinder block if necessary.

- Check for scratches or seizure. If seizure is found, hone it.

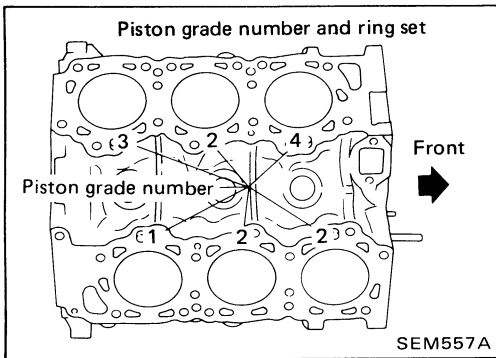
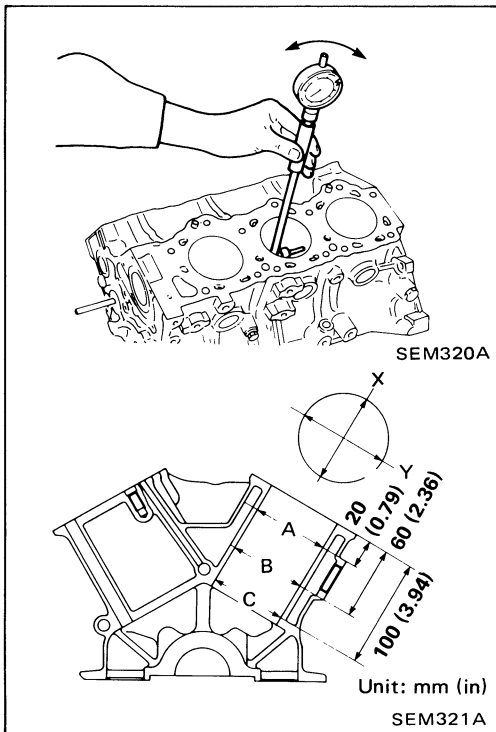

- If either cylinder block or piston is replaced with a new one, select piston of the same grade number punched on cylinder block upper surface.

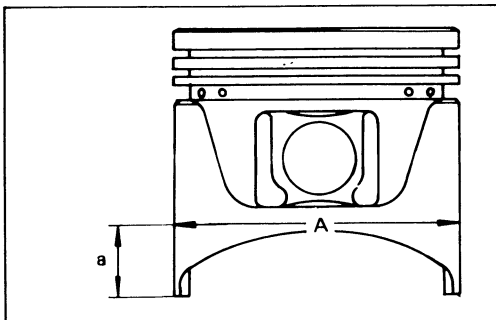

- Measure piston skirt diameter.

Piston diameter "A":

Refer to S.D.S.

Measuring point "a" (Distance from the bottom):

20 mm (0.79 in)

- Check that piston-to-bore clearance is within the specification.

Piston-to-bore clearance "B":

0.025 - 0.045 mm (0.0010 - 0.0018 in)

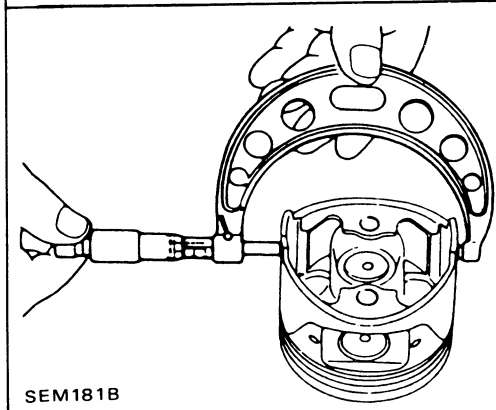

Inspection (Cont'd)

- Determine piston oversize according to amount of cylinder wear.

Oversize pistons are available for service. Refer to S.D.S.

- Cylinder size is determined by adding piston-to-bore clearance to piston diameter "A".

Rebored size calculation:

$$D = A + B - C = A + [0.005 \text{ to } 0.025 \text{ mm} \\ (0.0002 \text{ to } 0.0010 \text{ in})]$$

where,

D: Bored diameter

A: Piston diameter as measured

B: Piston-to-bore clearance

C: Honing allowance 0.02 mm (0.0008 in)

- Install main bearing caps, and tighten to the specified torque to prevent distortion of cylinder bores in final assembly.
- Cut cylinder bores.
 - **When any cylinder needs boring, all other cylinders must also be bored.**
 - **Do not cut too much out of the cylinder bore at a time. Cut only 0.05 mm (0.0020 in) or so in diameter at a time.**
- Hone the cylinders to obtain specified piston-to-bore clearance.
- Measure the finished cylinder bore for out-of-round and taper.
 - **Measurement should be done after cylinder bore cools down.**

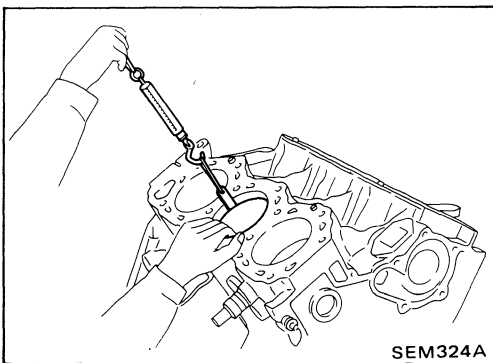
**Using feeler gauge**

When pulling feeler gauge straight upward, measure the extracting force. It is recommended that piston and cylinder be heated to 20°C (68°F).

Feeler gauge thickness:

0.04 mm (0.0016 in)

Extracting force:

2.0 - 14.7 N (0.2 - 1.5 kg, 0.4 - 3.3 lb)

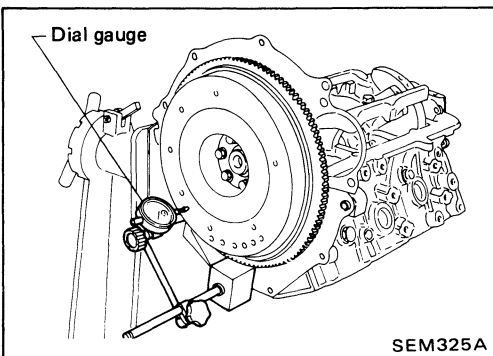
**FLYWHEEL RUNOUT**

Runout (Total indicator reading):

Flywheel

Less than 0.15 mm (0.0059 in)

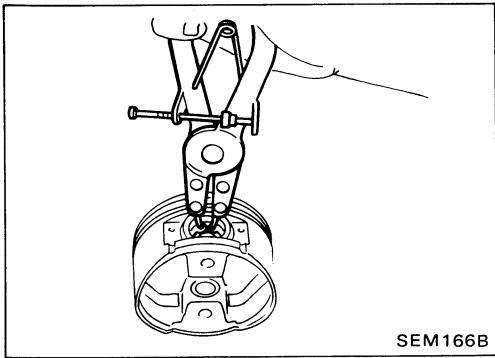

Assembly

PISTON

1. Install a new snap ring on one side of the piston pin hole.

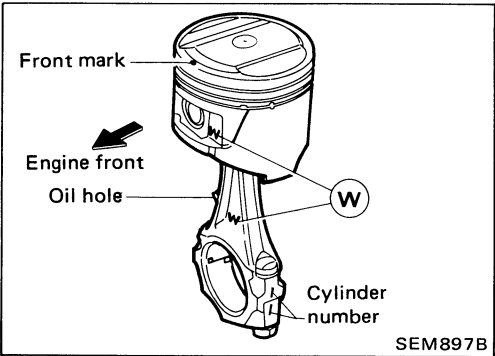

2. Heat piston to 60 to 70°C (140 to 158°F) and assemble piston, piston pin, connecting rod and new snap ring.

- **Align the direction of piston and connecting rod.**
- **Numbers stamped on connecting rod and cap correspond to each cylinder.**
- **After assembly, make sure piston swings smoothly.**

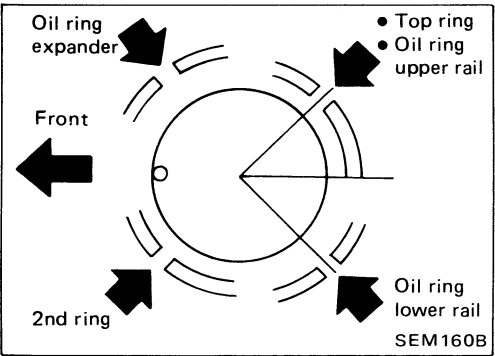

3. Set piston rings as shown.

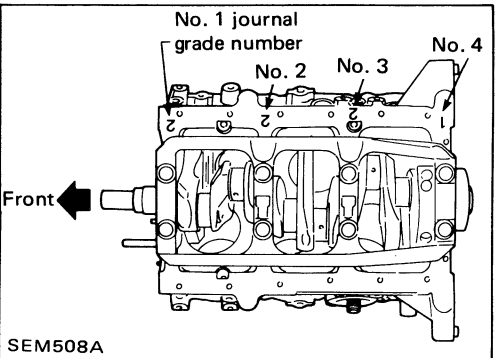

4. If crankshaft, cylinder block and main bearings are replaced with new ones, it is necessary to select thickness of main bearings as follows:

a. Grade number of each cylinder block main journal is punched on the respective cylinder block.

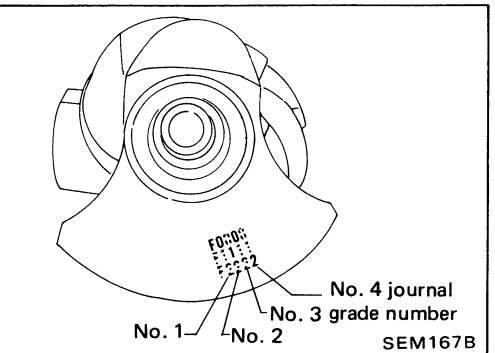

b. Grade number of each crankshaft main journal is punched on the respective crankshaft.

Assembly (Cont'd)

c. Select main bearing with suitable thickness according to the following table.

Main bearing grade number:

	Main journal grade number	0	1	2
Crankshaft journal grade number	0	0	1	2
	1	1	2	3
	2	2	3	4

For example:

Main journal grade number: 1
 Crankshaft journal grade number: 2
 Main bearing grade number = 1 + 2
 = 3

5. If crankshaft, cylinder block or main bearing is reused again, measure main bearing clearance.

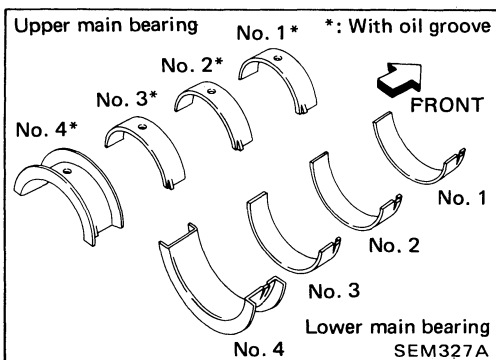

CRANKSHAFT

1. Set main bearings in their proper positions on cylinder block and main bearing cap.

- Confirm that correct main bearings are used. Refer to "Inspection".

2. Install crankshaft and main bearing caps and tighten bolts to the specified torque.

- Prior to tightening bearing cap bolts, place bearing cap in its proper position by shifting crankshaft in the axial direction.
- Tighten bearing cap bolts gradually in two or three stages. Start with the center bearing and move outward sequentially.
- After securing bearing cap bolts, make sure crankshaft turns smoothly by hand.

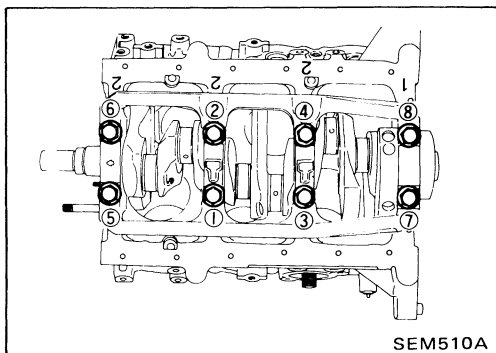

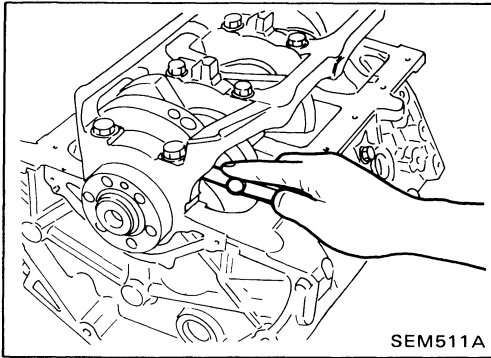
Assembly (Cont'd)

3. Measure crankshaft end play.

Crankshaft end play:**Standard**

0.05 - 0.17 mm (0.0020 - 0.0067 in)

Limit

0.30 mm (0.0118 in)

If beyond the limit, replace bearing with a new one.

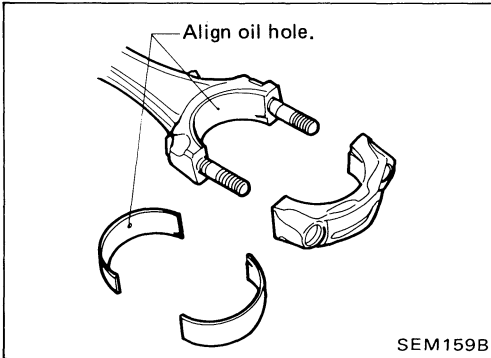

4. Install connecting rod bearings in connecting rods and connecting rod caps.

- Confirm that correct bearings are used. **Refer to "Inspection"**.
- Install bearings so that oil hole in connecting rod aligns with oil hole of bearing.

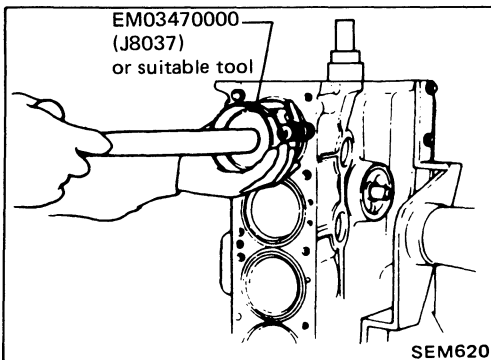

5. Install pistons with connecting rods.

- (1) Install them into corresponding cylinders with Tool.

- **Be careful not to scratch cylinder wall by connecting rod.**
- **Arrange so that front mark on piston head faces toward front of engine.**

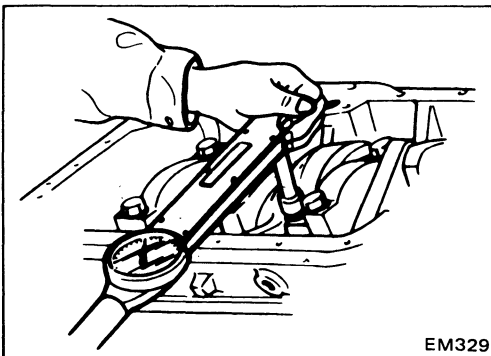

- (2) Install connecting rod bearing caps.

Tighten connecting rod bearing cap nuts to the specified torque.

☞: Connecting rod bearing cap nut

- (1) Tighten to 14 to 16 N·m

(1.4 to 1.6 kg·m, 10 to 12 ft·lb).

- (2) Tighten to 38 to 44 N·m

(3.9 to 4.5 kg·m, 28 to 33 ft·lb) or if you have an angle wrench, tighten bolts 60 to 65 degrees clockwise.

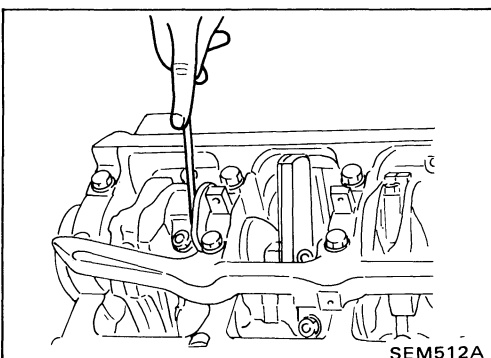

6. Measure connecting rod side clearance.

Connecting rod side clearance:**Standard**

0.20 - 0.35 mm (0.0079 - 0.0138 in)

Limit

0.40 mm (0.0157 in)

If beyond the limit, replace connecting rod and/or crankshaft.

Assembly (Cont'd)
REPLACING PILOT BUSHING

1. Remove pilot bushing (M/T) or pilot convertor (A/T).

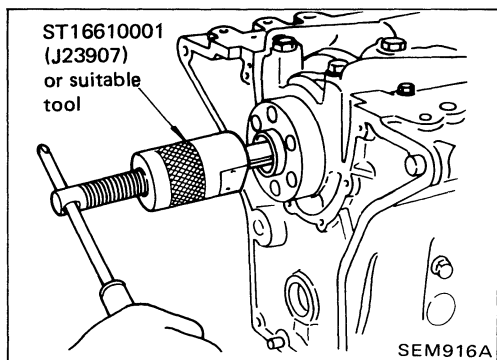

2. Install pilot bushing (M/T) or pilot convertor (A/T).

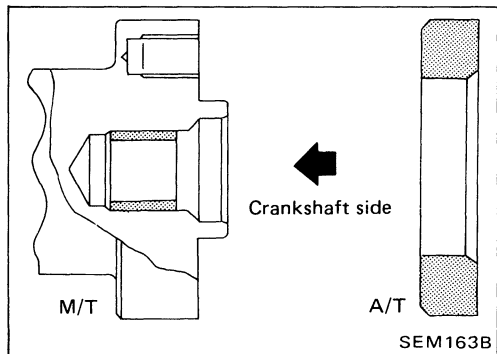

General Specifications

Cylinder arrangement	V-6	
Displacement	cm ³ (cu in)	2,960 (180.62)
Bore and Stroke	mm (in)	87 x 83 (3.43 x 3.27)
Valve arrangement	O.H.C.	
Firing order	1-2-3-4-5-6	
Number of piston rings		
Compression	2	
Oil	1	
Number of main bearings	4	
Compression ratio	9.0	

Unit: kPa (kg/cm², psi)/rpm

Compression pressure	
Standard	1,196 (12.2, 173)/300
Minimum	883 (9.0, 128)/300
Differential limit between cylinders	98 (1.0, 14)/300

Cylinder number

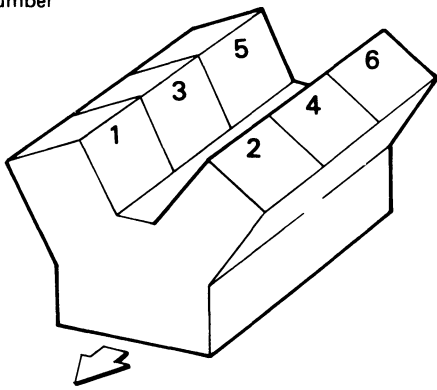

FRONT

SEM713A

Inspection and Adjustment

CYLINDER HEAD

Unit: mm (in)		
	Standard	Limit
Head surface distortion	Less than 0.05 (0.0020)	0.1 (0.004)

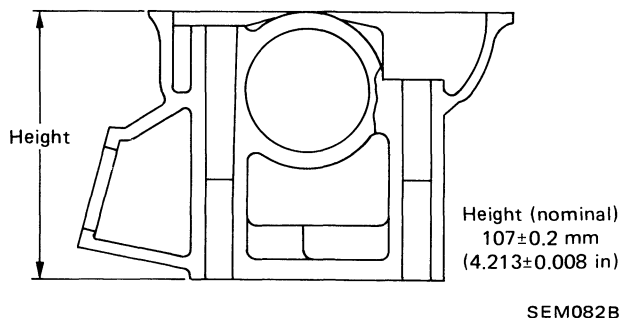

Valve spring

Unit: mm (in)			
Free height	mm (in)	Outer	51.2 (2.016)
		Inner	44.1 (1.736)
Pressure height	mm/N (mm/kg, in/lb)	Outer	30.0/523.7 (30.0/53.4, 1.181/117.7)
		Inner	25.0/255.0 (25.0/26.0, 0.984/57.3)
Out-of-square	mm (in)	Outer	2.2 (0.087)
		Inner	1.9 (0.075)

Hydraulic valve lifter

Unit: mm (in)	
Lifter outside diameter	15.947 - 15.957 (0.6278 - 0.6282)
Lifter guide inside diameter	16.000 - 16.013 (0.6299 - 0.6304)
Clearance between lifter and lifter guide	0.043 - 0.066 (0.0017 - 0.0026)

VALVE

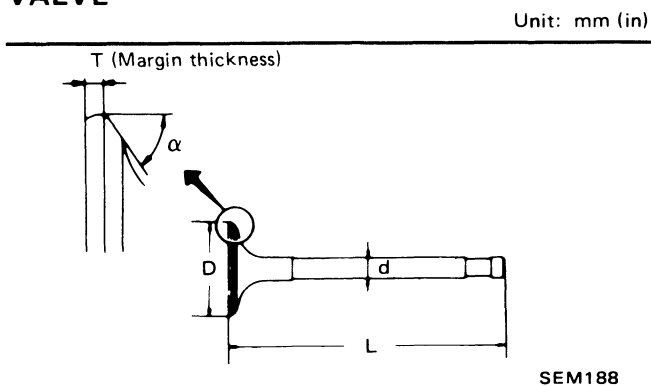

Valve head diameter "D"	
Intake	42.0 - 42.2 (1.654 - 1.661)
Exhaust	35.0 - 35.2 (1.378 - 1.386)
Valve length "L"	
Intake	125.3 - 125.9 (4.933 - 4.957)
Exhaust	124.2 - 124.8 (4.890 - 4.913)
Valve stem diameter "d"	
Intake	6.965 - 6.980 (0.2742 - 0.2748)
Exhaust	7.945 - 7.960 (0.3128 - 0.3134)
Valve seat angle "α"	
Intake	45° 15' - 45° 45'
Exhaust	
Valve margin "T"	
Intake	1.3 (0.051)
Exhaust	1.5 (0.059)
Valve margin "T" limit	More than 0.5 (0.020)
Valve stem end surface grinding limit	Less than 0.2 (0.008)
Valve clearance	
Intake	0 (0)
Exhaust	0 (0)

Inspection and Adjustment (Cont'd)

Valve guide

		Unit: mm (in)	
		Standard	Service
Valve guide			
Outer diameter	Intake	11.023 - 11.034 (0.4340 - 0.4344)	11.223 - 11.234 (0.4418 - 0.4423)
	Exhaust	12.023 - 12.034 (0.4733 - 0.4738)	12.223 - 12.234 (0.4812 - 0.4817)
Valve guide			
Inner diameter [Finished size]	Intake	7.000 - 7.018 (0.2756 - 0.2763)	
	Exhaust	8.000 - 8.018 (0.3150 - 0.3157)	
Cylinder head valve guide hole diameter	Intake	10.975 - 10.996 (0.4321 - 0.4329)	11.175 - 11.196 (0.4400 - 0.4408)
	Exhaust	11.975 - 11.996 (0.4715 - 0.4723)	12.175 - 12.196 (0.4793 - 0.4802)
Interference fit of valve guide	Intake	0.027 - 0.059 (0.0011 - 0.0023)	
	Exhaust	0.027 - 0.059 (0.0011 - 0.0023)	
		Standard	Max. tolerance
Stem to guide clearance	Intake	0.020 - 0.053 (0.0008 - 0.0021)	0.10 (0.0039)
	Exhaust	0.040 - 0.073 (0.0016 - 0.0029)	
Valve deflection limit		—	0.20 (0.0079)

Rocker shaft and rocker arm

		Unit: mm (in)
Rocker shaft		
Outer diameter		17.979 - 18.000 (0.7078 - 0.7087)
Rocker arm		
Inner diameter		18.007 - 18.028 (0.7089 - 0.7098)
Clearance between rocker arm and rocker shaft		0.007 - 0.049 (0.0003 - 0.0019)

Intake valve seat

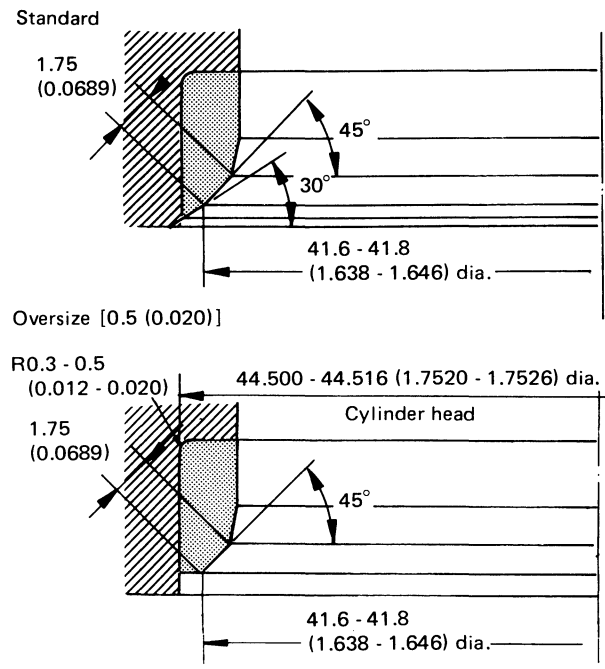

Unit: mm (in)

SEM755A

Exhaust valve seat

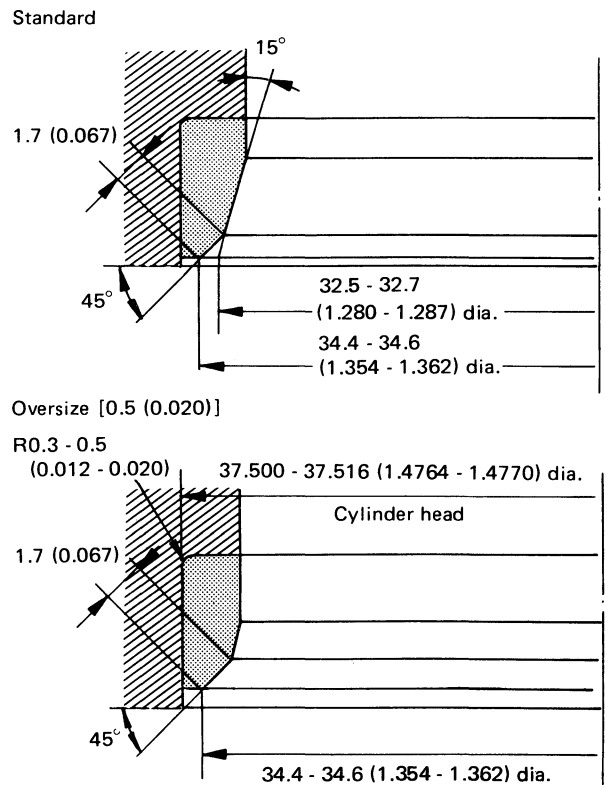

Unit: mm (in)

SEM756A

Inspection and Adjustment (Cont'd)

PISTON, PISTON RING AND PISTON PIN

Available piston

Unit: mm (in)

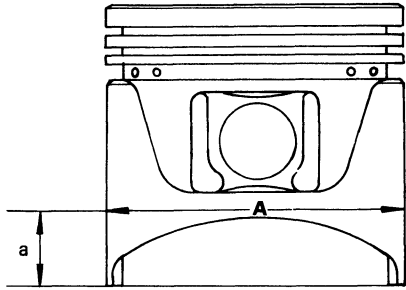

SEM891B

Piston skirt diameter "A"	Standard	
	Grade No. 1	86.965 - 86.975 (3.4238 - 3.4242)
	Grade No. 2	86.975 - 86.985 (3.4242 - 3.4246)
	Grade No. 3	86.985 - 86.995 (3.4246 - 3.4250)
	Grade No. 4	86.995 - 87.005 (3.4250 - 3.4254)
0.25 (0.0098) - oversize (Service)	Grade No. 5	87.005 - 87.015 (3.4254 - 3.4258)
		87.215 - 87.265 (3.4337 - 3.4356)
0.50 (0.0197) - oversize (Service)		87.465 - 87.515 (3.4435 - 3.4455)
"a" dimension		20 (0.79)
Piston pin hole diameter		20.969 - 20.981 (0.8255 - 0.8260)
Piston clearance to cylinder block		0.025 - 0.045 (0.0010 - 0.0018)

Piston ring

Unit: mm (in)

	Standard	Limit
Side clearance		
Top	0.040 - 0.073 (0.0016 - 0.0029)	0.1 (0.004)
2nd	0.030 - 0.063 (0.0012 - 0.0025)	
Oil	0.015 - 0.190 (0.0006 - 0.0075)	—
Ring gap		
Top	0.21 - 0.44 (0.0083 - 0.0173)	1.0 (0.039)
2nd	0.18 - 0.44 (0.0071 - 0.0173)	
Oil (rail ring)	0.20 - 0.76 (0.0079 - 0.0299)	

Piston pin

Unit: mm (in)

Piston pin outer diameter	20.971 - 20.983 (0.8256 - 0.8261)
Interference fit of piston pin to piston	-0.008 to 0.004 (-0.0003 to 0.0002)
Piston pin to connecting rod bush clearance	0.005 - 0.017 (0.0002 - 0.0007)

*Values measured at ambient temperature of 20°C (68°F)

CONNECTING ROD

Unit: mm (in)

Center distance	154.10 - 154.20 (6.0669 - 6.0709)
Bend, torsion [per 100 (3.94)]	
Limit	0.10 (0.0039)
Piston pin bushing inner diameter*	20.982 - 20.994 (0.8261 - 0.8265)
Connecting rod big end inner diameter	53.000 - 53.013 (2.0866 - 2.0871)
Side clearance	
Standard	0.20 - 0.35 (0.0079 - 0.0138)
Limit	0.40 (0.0157)

*After installing in connecting rod

Inspection and Adjustment (Cont'd)

CAMSHAFT AND CAMSHAFT BEARING

Unit: mm (in)

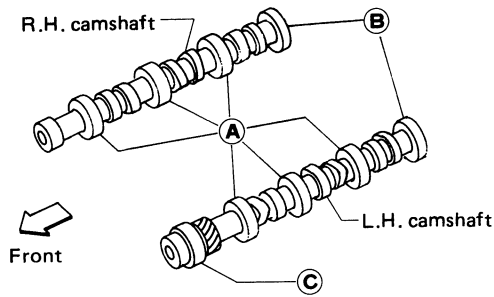

SEM893B

	Standard	Max. tolerance
Camshaft journal to bearing clearance	0.045 - 0.090 (0.0018 - 0.0035)	0.15 (0.0059)
Inner diameter of camshaft bearing	A : 47.000 - 47.025 (1.8504 - 1.8514)	—
	B : 42.500 - 42.525 (1.6732 - 1.6742)	—
	C : 48.000 - 48.025 (1.8898 - 1.8907)	—
Outer diameter of camshaft journal	A : 46.920 - 46.940 (1.8472 - 1.8480)	—
	B : 42.420 - 42.440 (1.6701 - 1.6709)	—
	C : 47.920 - 47.940 (1.8866 - 1.8874)	—
Camshaft runout [T.I.R.*]	Less than 0.04 (0.0016)	0.1 (0.004)
Camshaft end play	0.03 - 0.06 (0.0012 - 0.0024)	—

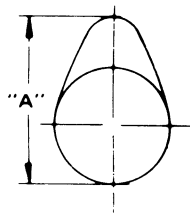

EM671

Cam height "A"	
Intake	39.537 - 39.727 (1.5566 - 1.5641)
Exhaust	
Wear limit of cam height	0.15 (0.0059)

*Total indicator reading

Valve timing

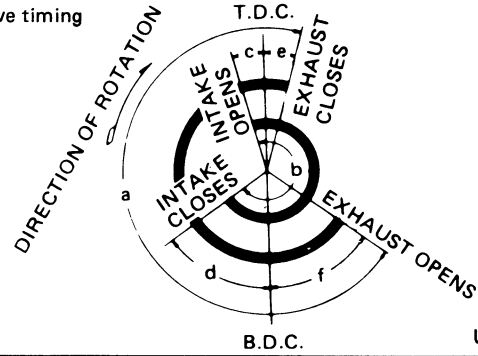

EM120

Unit: degree

a	b	c	d	e	f
248°	248°	10°	58°	10°	58°

CYLINDER BLOCK

Unit: mm (in)

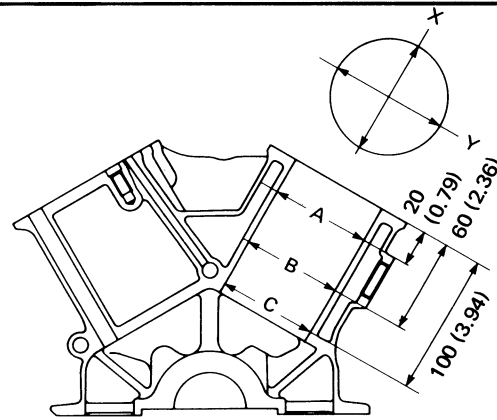

SEM321A

Surface flatness	
Standard	Less than 0.03 (0.0012)
Limit	0.10 (0.0039)
Height (nominal)	227.65±0.05 (8.9626±0.0020)
Cylinder bore	
Inner diameter	
Standard	
Grade No. 1	87.000 - 87.010 (3.4252 - 3.4256)
Grade No. 2	87.010 - 87.020 (3.4256 - 3.4260)
Grade No. 3	87.020 - 87.030 (3.4260 - 3.4264)
Grade No. 4	87.030 - 87.040 (3.4264 - 3.4268)
Grade No. 5	87.040 - 87.050 (3.4268 - 3.4272)
Wear limit	0.20 (0.0079)
Out-of-round (X-Y)	Less than 0.015 (0.0006)
Taper (A-B-C)	Less than 0.015 (0.0006)
Main journal inner diameter	
Grade No. 0	66.645 - 66.654 (2.6238 - 2.6242)
Grade No. 1	66.654 - 66.663 (2.6242 - 2.6245)
Grade No. 2	66.663 - 66.672 (2.6245 - 2.6249)
Difference in inner diameter between cylinders	
Standard	Less than 0.05 (0.0020)
Wear limit	0.20 (0.0079)
Feeler gauge extracting force	N (kg, lb)
[with gauge thickness 0.04 mm (0.0016 in)]	2.0 - 14.7 (0.2 - 1.5, 0.4 - 3.3)

Inspection and Adjustment (Cont'd)

CRANKSHAFT

Unit: mm (in)

Main journal dia. "Dm"	
Grade No. 0	62.967 - 62.975 (2.4790 - 2.4793)
Grade No. 1	62.959 - 62.967 (2.4787 - 2.4790)
Grade No. 2	62.951 - 62.959 (2.4784 - 2.4787)
Pin journal dia. "Dp"	
	49.955 - 49.974 (1.9667 - 1.9675)
Center distance "r"	
	41.5 (1.634)
Out-of-round (X-Y)	
Standard	Less than 0.005 (0.0002)
Taper (A-B)	
Standard	Less than 0.005 (0.0002)
Runout [T.I.R.]	
Standard	Less than 0.10 (0.0039)
Free end play	
Standard	0.05 - 0.17 (0.0020 - 0.0067)
Limit	0.30 (0.0118)

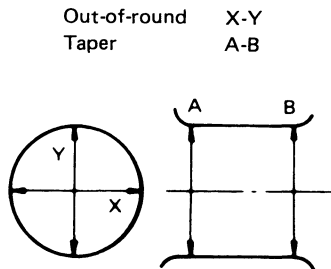
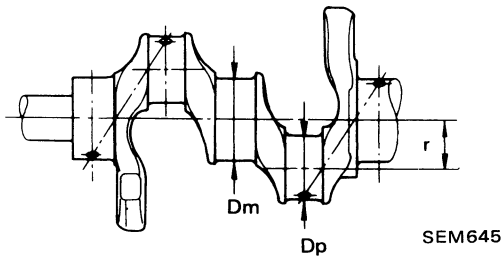

AVAILABLE MAIN BEARING

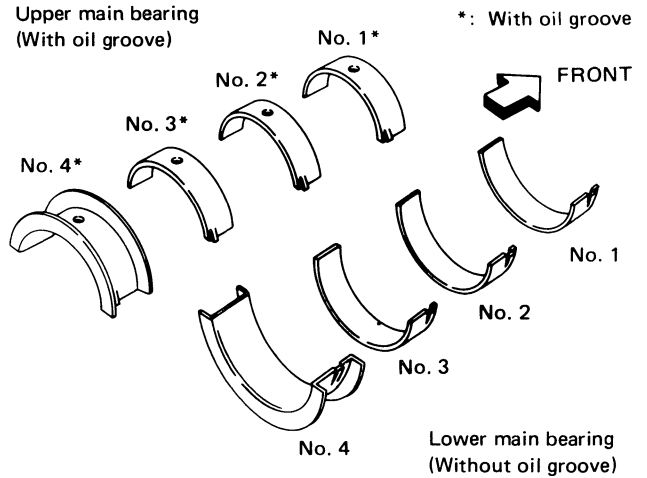

SEM327A

No. 1 main bearing

Grade number	Thickness "T" mm (in)	Width "W" mm (in)	Identification color
0	1.817 - 1.821 (0.0715 - 0.0717)		Black
1	1.821 - 1.825 (0.0717 - 0.0719)		Brown
2	1.825 - 1.829 (0.0719 - 0.0720)	22.5 (0.886)	Green
3	1.829 - 1.833 (0.0720 - 0.0722)		Yellow
4	1.833 - 1.837 (0.0722 - 0.0723)		Blue

No. 2 and 3 main bearing

Grade number	Thickness "T" mm (in)	Width "W" mm (in)	Identification color
0	1.817 - 1.821 (0.0715 - 0.0717)		Black
1	1.821 - 1.825 (0.0717 - 0.0719)		Brown
2	1.825 - 1.829 (0.0719 - 0.0720)	19.0 (0.748)	Green
3	1.829 - 1.833 (0.0720 - 0.0722)		Yellow
4	1.833 - 1.837 (0.0722 - 0.0723)		Blue

Inspection and Adjustment (Cont'd)

No. 4 main bearing

Grade number	Thickness "T" mm (in)	Identification color
0	1.817 - 1.821 (0.0715 - 0.0717)	Black
1	1.821 - 1.825 (0.0717 - 0.0719)	Brown
2	1.825 - 1.829 (0.0719 - 0.0720)	Green
3	1.829 - 1.833 (0.0720 - 0.0722)	Yellow
4	1.833 - 1.837 (0.0722 - 0.0723)	Blue

Main bearing 0.25 mm (0.0098 in) undersize

Unit: mm (in)

Thickness "T"	1.948 - 1.956 (0.0767 - 0.0770)
---------------	---------------------------------

AVAILABLE CONNECTING ROD BEARING

Connecting rod bearing undersize

Unit: mm (in)

	Crank pin journal diameter "Dp"
Standard	49.955 - 49.974 (1.9667 - 1.9675)
Undersize	
0.08 (0.0031)	49.881 - 49.894 (1.9638 - 1.9643)
0.12 (0.0047)	49.841 - 49.854 (1.9622 - 1.9628)
0.25 (0.0098)	49.711 - 49.724 (1.9571 - 1.9576)

MISCELLANEOUS COMPONENTS

Unit: mm (in)

Flywheel	
Runout [T.I.R.]	Less than 0.15 (0.0059)
Camshaft sprocket	
Runout [T.I.R.]	Less than 0.1 (0.004)

Bearing clearance

Unit: mm (in)

Main bearing clearance	
Standard	0.028 - 0.055 (0.0011 - 0.0022)
Limit	0.090 (0.0035)
Connecting rod bearing clearance	
Standard	0.014 - 0.054 (0.0006 - 0.0021)
Limit	0.090 (0.0035)

Tightening Torque

ENGINE OUTER PARTS

Unit	N-m	kg-m	ft-lb
Intake manifold bolt	16 - 20	1.6 - 2.0	12 - 14
Intake manifold nut	24 - 27	2.4 - 2.8	17 - 20
Thermal transmitter	15 - 20	1.5 - 2.0	11 - 14
Exhaust manifold	18 - 22	1.8 - 2.2	13 - 16
Exhaust connecting tube	22 - 27	2.2 - 2.8	16 - 20
Crankshaft pulley	123 - 132	12.5 - 13.5	90 - 98
Water inlet	16 - 21	1.6 - 2.1	12 - 15
P.C.V. valve	29 - 39	3.0 - 4.0	22 - 29
Distributor bolt	4.9 - 5.9	0.5 - 0.6	3.6 - 4.3
Alternator adjusting bar bolt	14 - 17	1.4 - 1.7	10 - 12
E.G.R. control valve	18 - 23	1.8 - 2.3	13 - 17
E.G.R. tube	34 - 44	3.5 - 4.5	25 - 33
Temperature sensor	12 - 16	1.2 - 1.6	9 - 12
Starter motor	30 - 36	3.1 - 3.7	22 - 27

ENGINE PARTS

Unit	N-m	kg-m	ft-lb
Rocker cover	1 - 3	0.1 - 0.3	0.7 - 2.2
Tensioner nut	43 - 58	4.4 - 5.9	32 - 43
Belt cover	3 - 5	0.3 - 0.5	2.2 - 3.6
Rocker shaft	18 - 22	1.8 - 2.2	13 - 16
Camshaft pulley	78 - 88	8.0 - 9.0	58 - 65
Cylinder head	Refer to "Installation" of CYLINDER HEAD.		
Camshaft locate plate	78 - 88	8.0 - 9.0	58 - 65
Water pump	16 - 21	1.6 - 2.1	12 - 15
Drain plug (Oil pan)	29 - 39	3.0 - 4.0	22 - 29
Oil pan	7 - 8	0.7 - 0.8	5.1 - 5.8
Oil pump regulator valve	39 - 69	4.0 - 7.0	29 - 51
Oil pump securing bolts	7 - 8	0.7 - 0.8	5.1 - 5.8
	22 - 29	2.2 - 3.0	16 - 22
Oil strainer	16 - 21	1.6 - 2.1	12 - 15
Oil strainer bracket	4 - 8	0.4 - 0.8	2.9 - 5.8
Flywheel	98 - 108	10 - 11	72 - 80
Rear oil seal retainer	6 - 7	0.6 - 0.7	4.3 - 5.1
Connecting rod	Refer to "Installation" of ENGINE OVERHAUL.		
Main bearing cap	90 - 100	9.2 - 10.2	67 - 74
Water drain plug	34 - 44	3.5 - 4.5	25 - 33
Spark plug	20 - 29	2.0 - 3.0	14 - 22

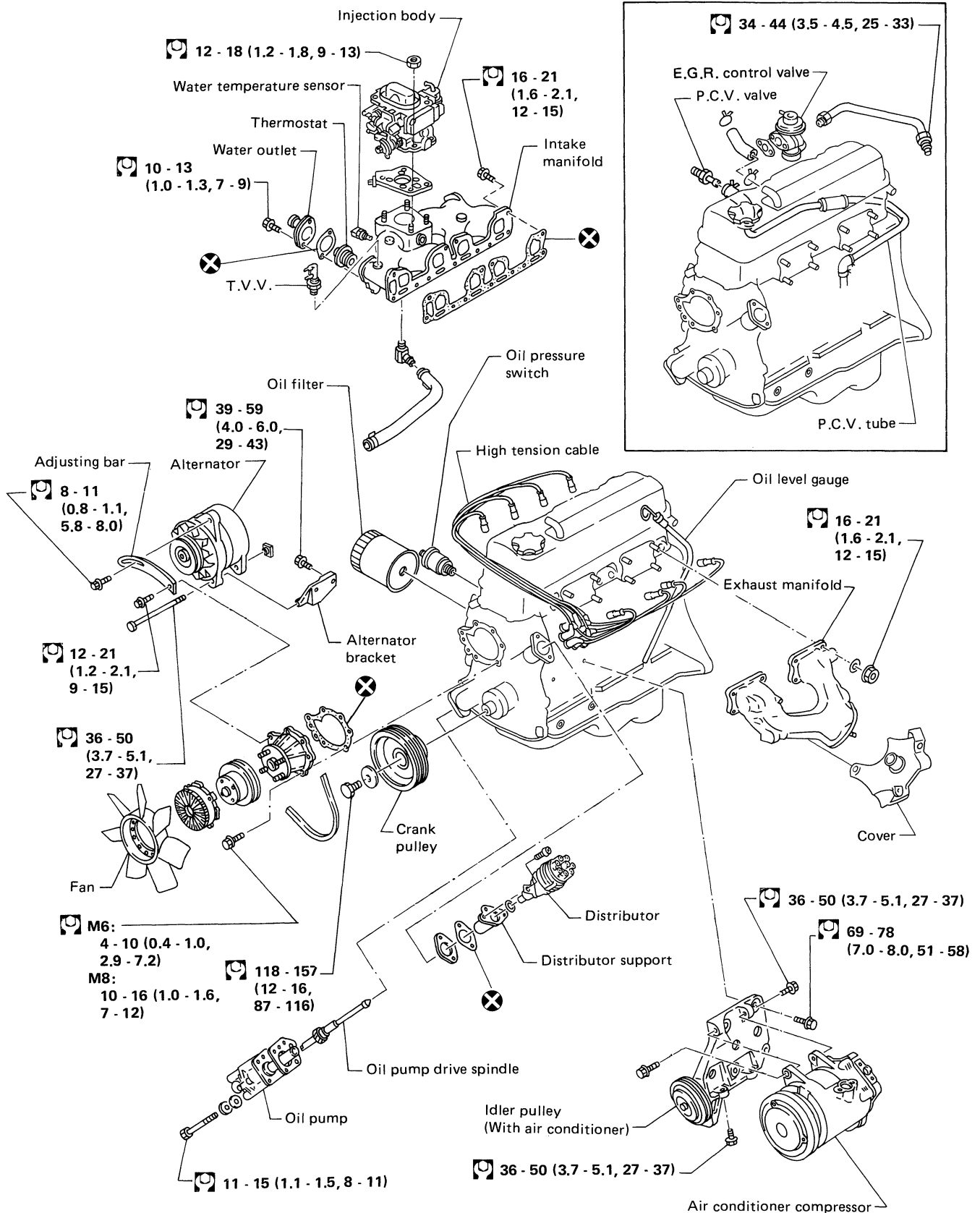

M6:
4 - 10 (0.4 - 1.0,
2.9 - 7.2)
M8:
10 - 16 (1.0 - 1.6,
7 - 12)

118 - 157
(12 - 16,
87 - 116)

: N·m (kg·m, ft·lb)
SEM194B

1. Warm up engine.
2. Remove all spark plugs.
Use a suitable plug wrench.

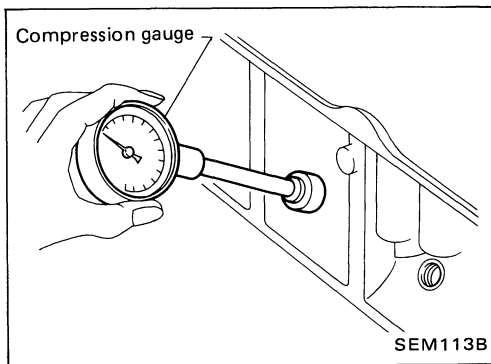
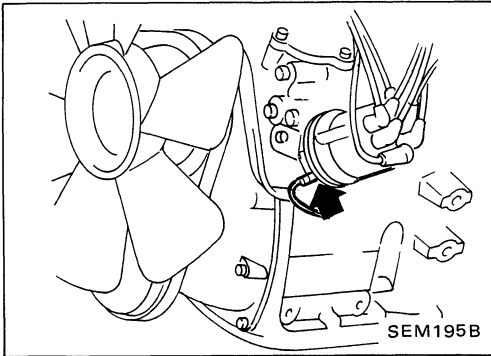

3. Disconnect distributor harness connector.

4. Attach a suitable compression tester.
5. Depress accelerator pedal to fully open throttle.
6. Crank engine and read gauge indication.

Compression pressure:

kPa (kg/cm², psi) at 350 rpm

Standard

1,196 (12.2, 173)

Minimum

902 (9.2, 131)

Differential limit between cylinders:

kPa (kg/cm², psi) at 350 rpm

98 (1.0, 14)

7. If cylinder compression in one or more cylinders is low, pour a small amount of engine oil into cylinders through the spark plug holes and retest compression.
 - If adding oil helps the compression pressure, chances are that piston rings are worn or damaged.
 - If pressure stays low, valve may be sticking or seating improperly.
 - If cylinder compression in any two adjacent cylinders is low, and if adding oil does not help the compression, there is leakage past the gasket surface.

CAUTION:

- a. Before installing timing chain, confirm that No. 1 cylinder is set at T.D.C. on compression stroke.
- b. Align silver color on timing chain and punch mark on crankshaft sprocket and camshaft sprocket.
- c. After removing timing chain, do not rotate crankshaft and camshaft separately because valves will hit piston head.

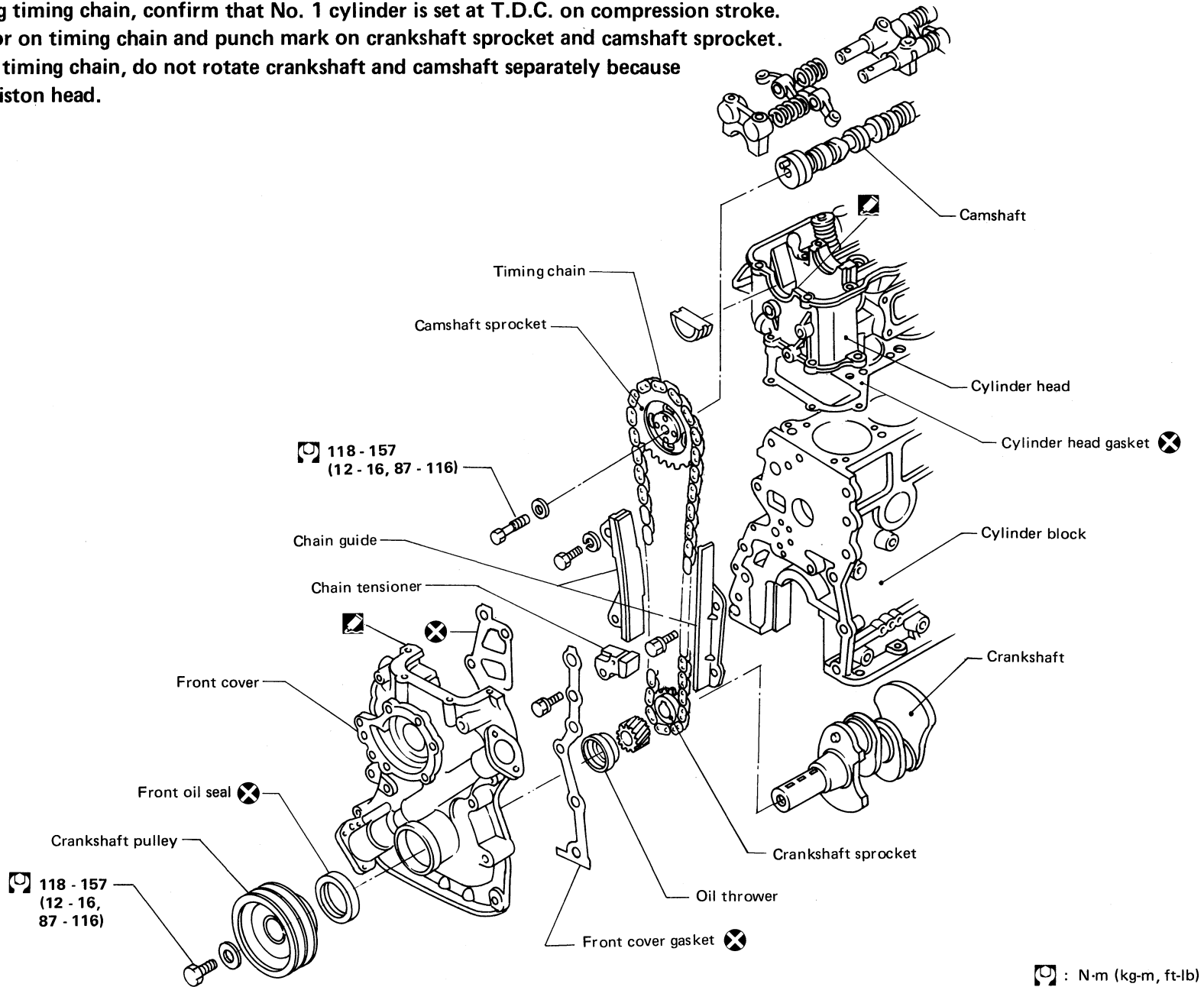

1. Drain coolant from radiator.
Be careful not to spill coolant on drive belts.
2. Remove radiator.
Refer to section LC.
3. Remove cooling fan.

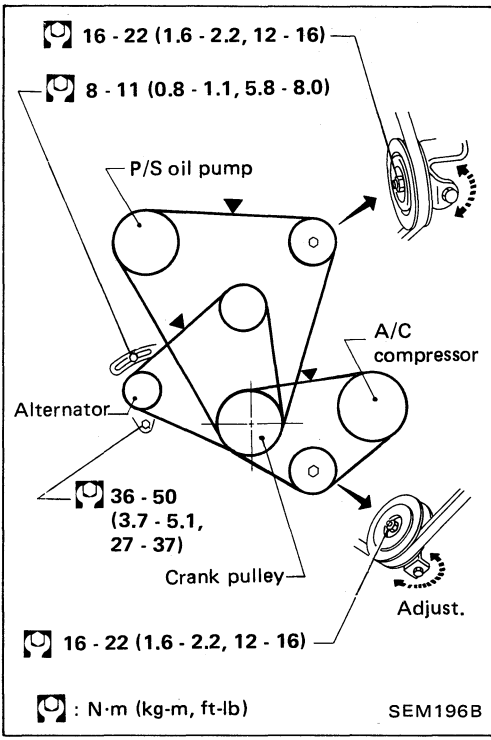

4. Remove the following belts.
 - Power steering drive belt
 - Compressor drive belt
 - Alternator drive belt

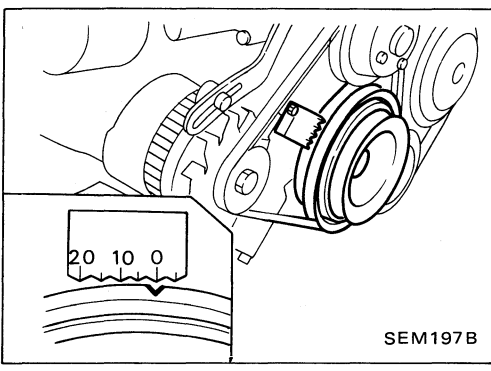

5. Set No. 1 cylinder at T.D.C. on its compression stroke, as the distributor rotor points in the direction shown in the figure.

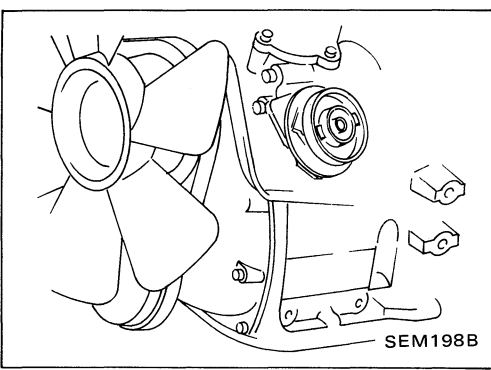

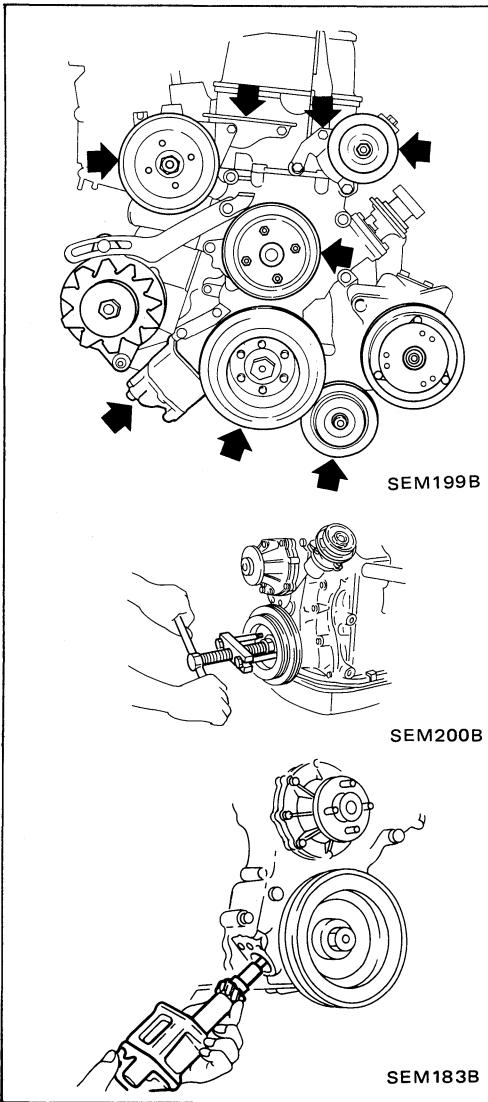

6. Remove the following parts.

- Power steering pump, idler pulley and power steering brackets
- Compressor idler pulley
- Crankshaft pulley
- Oil pump with pump drive spindle
- Rocker cover

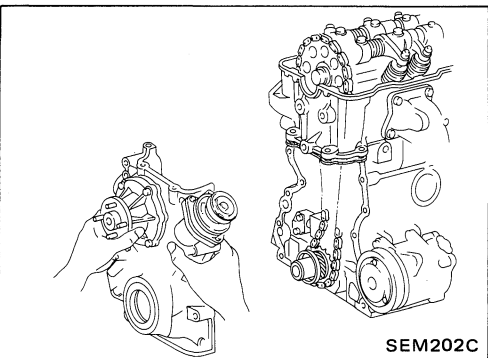

7. Remove oil pan. (Refer to OIL PAN REMOVAL AND INSTALLATION.)

8. Remove front cover. Be careful not to damage cylinder head gasket.

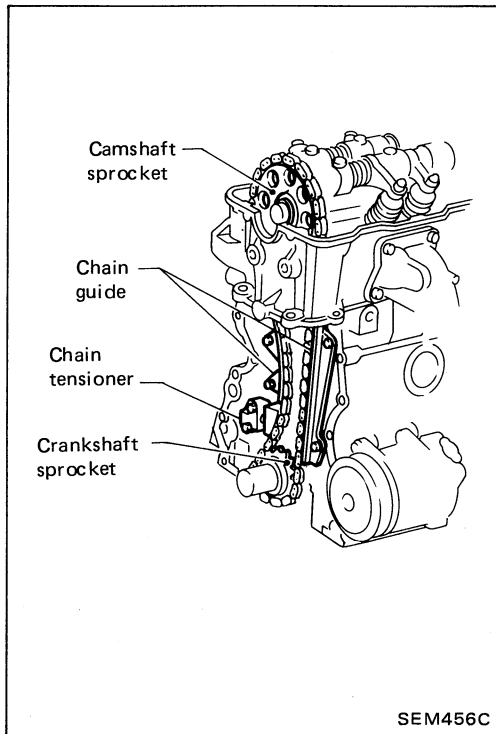

9. Remove the following parts.

- Chain tensioner
- Chain guides
- Timing chain and sprocket
- Oil thrower, oil pump drive gear and crankshaft sprocket

Carefully remove chain tensioner. Otherwise, spring may fall into oil pan.

After removing timing chain, do not rotate crankshaft and camshaft separately, because valves will hit piston head.

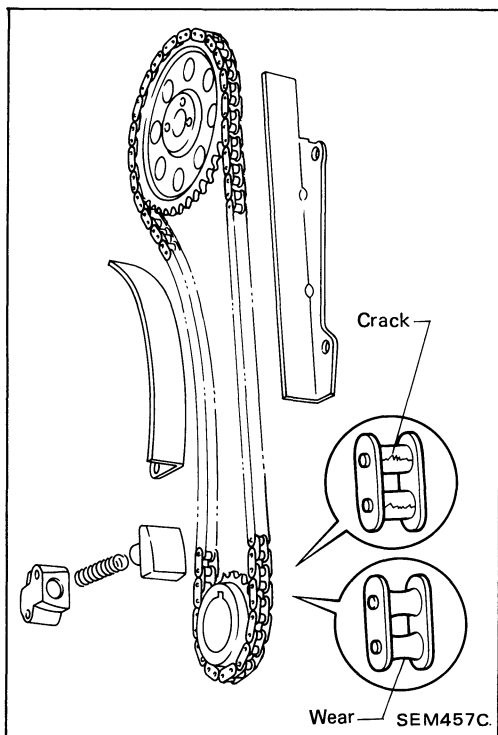

Check for damage and excessive wear at roller links. Replace if necessary.

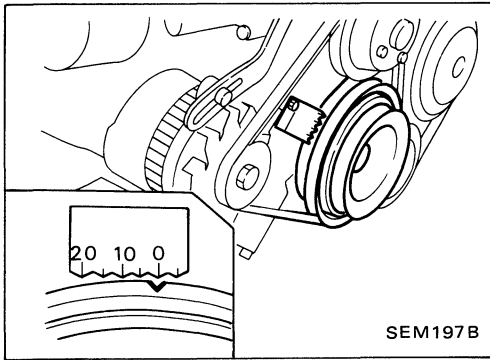

SEM197B

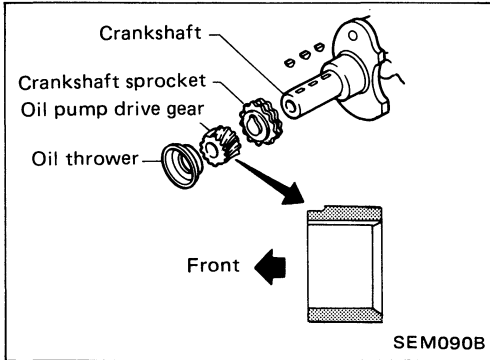

SEM090B

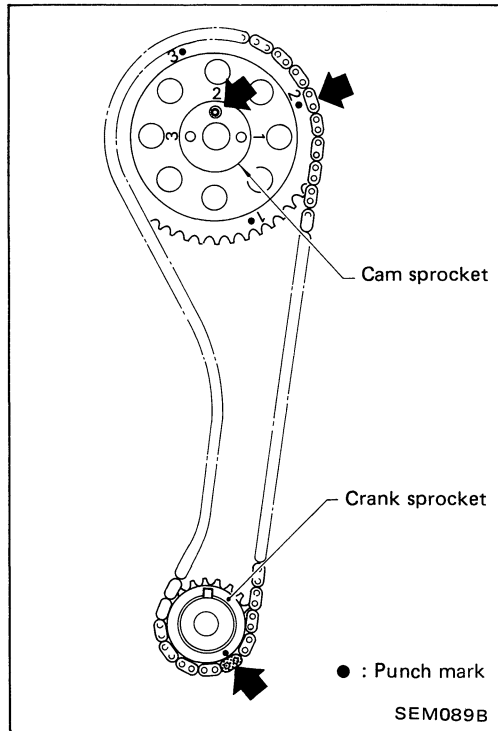

SEM089B

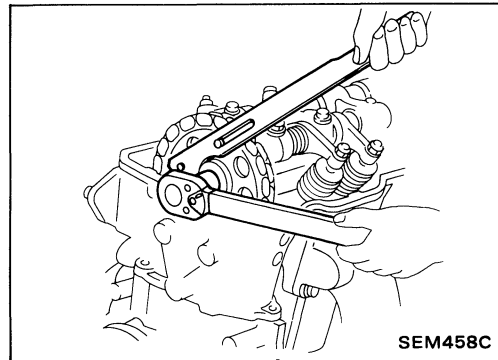

SEM458C

1. Confirm that No. 1 cylinder is set at T.D.C. on its compression stroke.

2. Install crankshaft sprocket, oil pump drive gear and oil thrower.

- a. Make sure that the mating marks of crankshaft sprocket face the engine front.
- b. Install oil pump drive gear so that large chamfered inner faces rearward.

3. Install cam sprocket and timing chain.

- a. Set timing chain by aligning its mating marks with those of crankshaft sprocket and camshaft sprocket.
- b. Camshaft sprocket should be installed by fitting the knock pin of camshaft into its No. 2 hole. And No. 2 timing mark must also be used.

4. Tighten camshaft sprocket bolt.

-  : Camshaft sprocket bolt
 118 - 157 N·m
 (12 - 16 kg·m, 87 - 116 ft·lb)

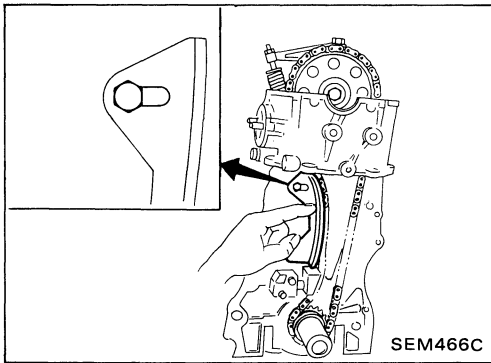

5. Install chain guide and chain tensioner.

 : Chain guide and chain tensioner bolt
6 - 10 N·m
(0.6 - 1.0 kg-m, 4.3 - 7.2 ft-lb)

- When installing chain guide, move chain guide in direction that gives strain to chain.

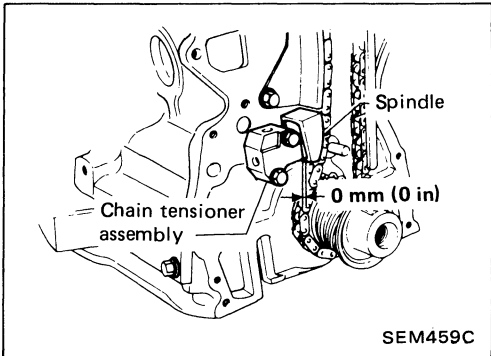

- Adjust the protrusion of chain tensioner spindle to 0 mm (0 in) with slack side chain guide.

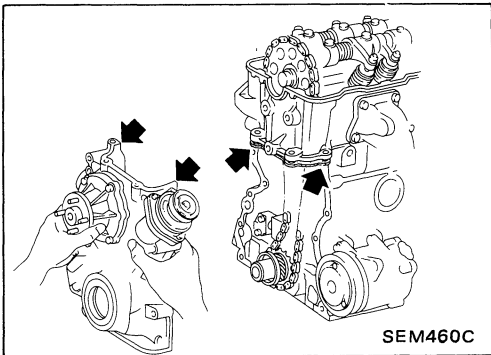

6. Apply sealant to upper and lower portions of front cover.
Remove excess sealant.

7. Apply lithium grease to sealing lip of crankshaft oil seal.

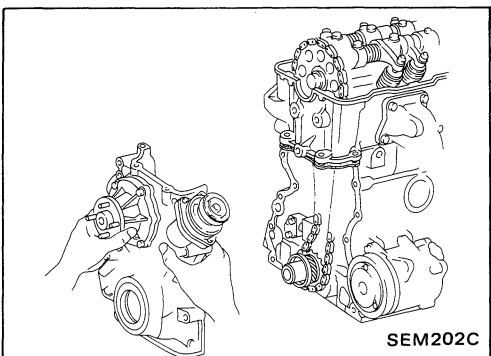

8. Install front cover.

Be careful not to damage cylinder head gasket.

 : Front cover bolt
Size M8
10 - 16 N·m
(1.0 - 1.6 kg-m, 7 - 12 ft-lb)
Size M6
4 - 10 N·m
(0.4 - 1.0 kg-m, 2.9 - 7.2 ft-lb)

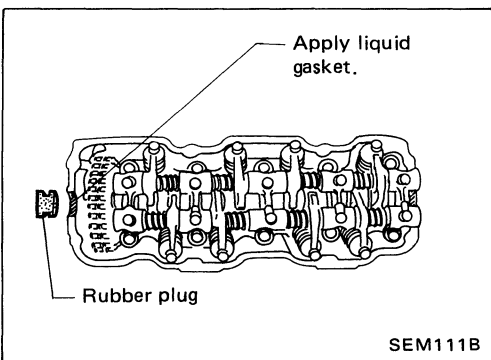

9. Apply liquid gasket to sealing point of cylinder head and install rubber plug. (Refer to page EM-85.)

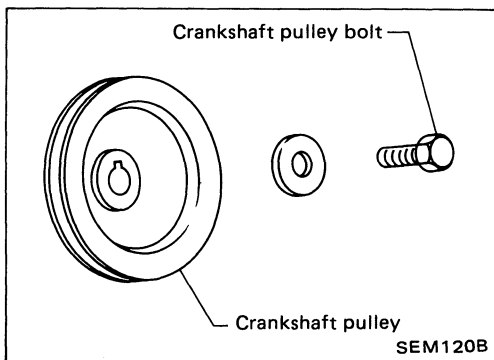

10. Install oil pan. (Refer to OIL PAN REMOVAL AND INSTALLATION.)

- ☞ : Oil pan bolt
6.3 - 8.3 N·m
(0.64 - 0.85 kg·m, 4.6 - 6.1 ft·lb)

11. Install crankshaft pulley.

- ☞ : Crankshaft pulley bolt
118 - 157 N·m
(12 - 16 kg·m, 87 - 116 ft·lb)

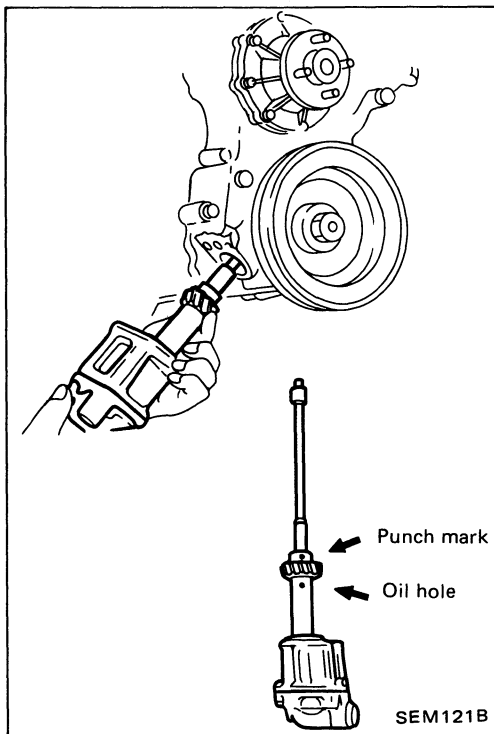

12. Install oil pump and distributor driving spindle in front cover.

- ☞ : 11 - 15 N·m
(1.1 - 1.5 kg·m, 8 - 11 ft·lb)

- Assemble oil pump and drive spindle, aligning driving spindle face with oil pump hole.
Refer to LC section.

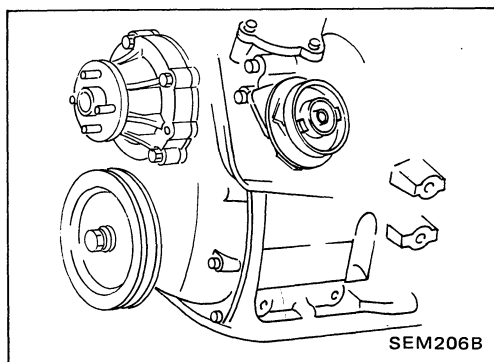

13. Ensure that No. 1 cylinder is set at T.D.C. on its compression stroke, and that distributor rotor is set at No. 1 cylinder spark position.

14. Slowly rotate crankshaft to ensure pistons do not interfere with valves.

- Do not rotate crankshaft quickly or with force. Otherwise, valves may be damaged by pistons.

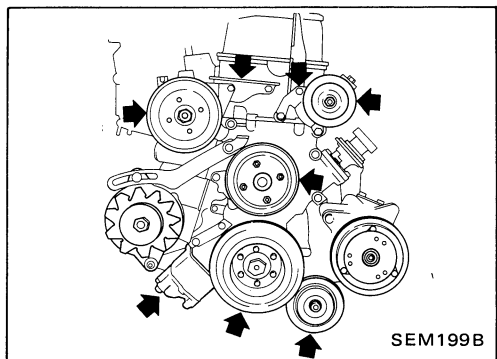

15. Install the following parts.

- Rocker cover
- Compressor idler pulley
- Power steering pump, idler pulley and power steering brackets.
- Fan and pulley
- Drive belts
- Other parts

16. Adjust drive belt tension.

Refer to MA section.

CAUTION:

- a. When installing sliding parts such as bearings, be sure to apply engine oil on the sliding surfaces.
- b. Use new gasket and oil seals.
- c. Be careful not to damage oil seal.

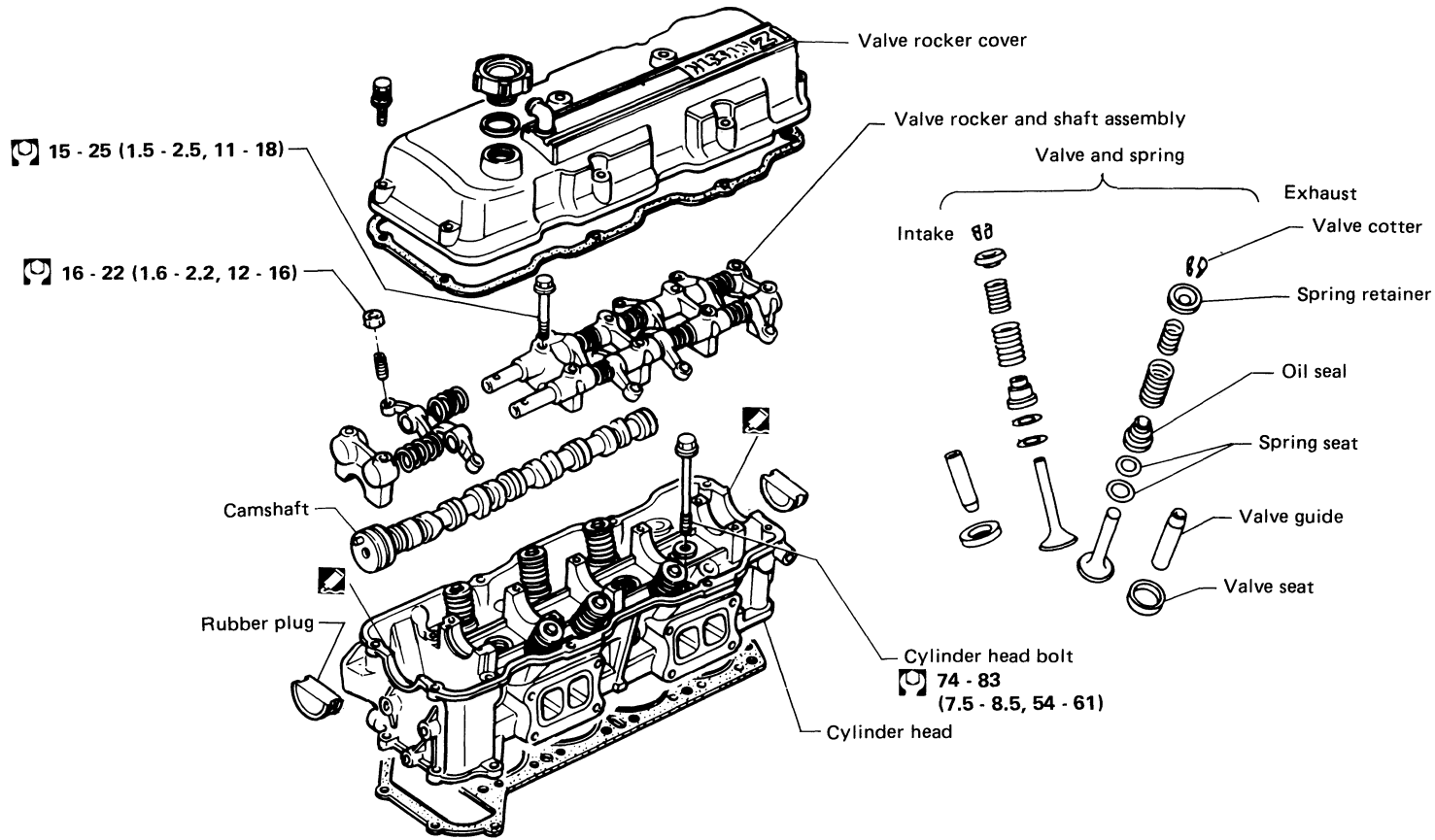

EM-72

: N·m (kg·m, ft·lb)
SEM1268

CYLINDER HEAD

Z24i

1. Drain coolant from radiator.
Be careful not to spill coolant on drive belts.
2. Remove the following parts.
 - Power steering pump drive belt
 - Power steering pump, idler pulley and power steering brackets
3. Disconnect front exhaust tube from exhaust manifold.

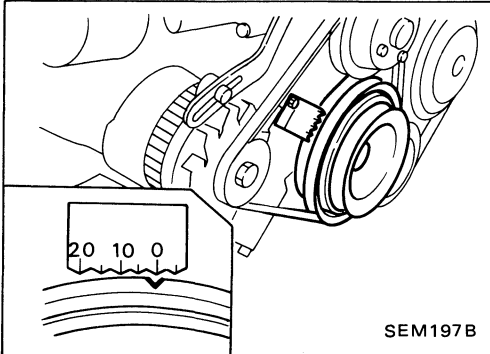

4. Remove rocker cover.
5. Set No. 1 cylinder at T.D.C. on its compression stroke as the distributor rotor points in the direction shown in the figure.

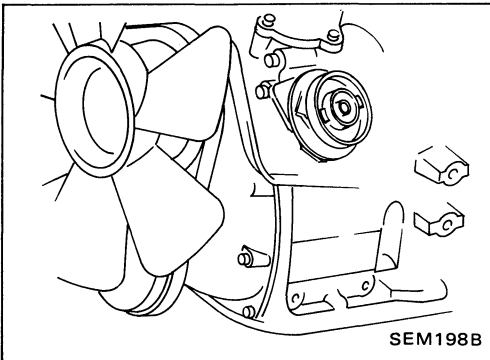

6. Loosen camshaft sprocket bolt.
7. Support timing chain by using Tool between timing chain.

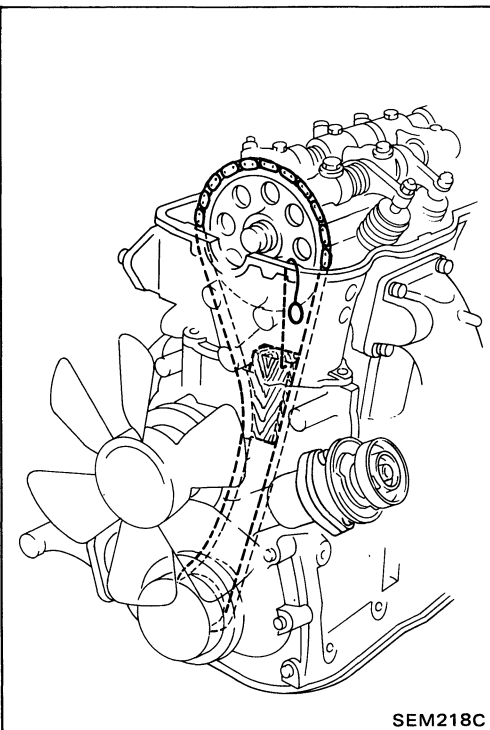

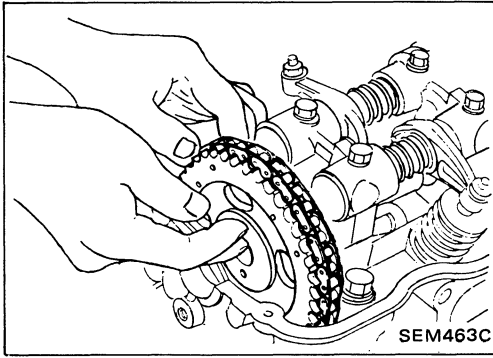

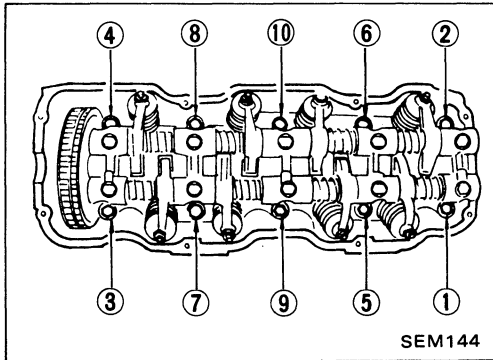

8. Remove camshaft sprocket.

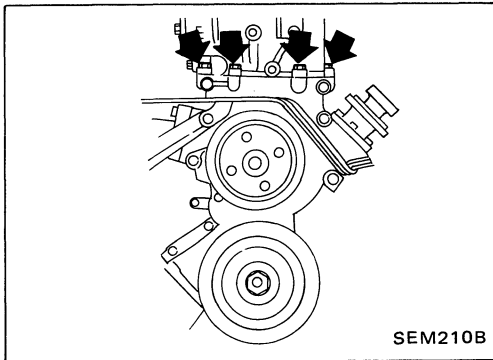

9. Loosen cylinder head bolts in the sequence shown.
Head warpage or cracking could result from removing them in incorrect order.



10. Remove cylinder head to front cover securing bolts.

 : 4 - 10 N·m (0.4 - 1.0 kg·m, 2.9 - 7.2 ft·lb)

11. Remove cylinder head with intake and exhaust manifold.

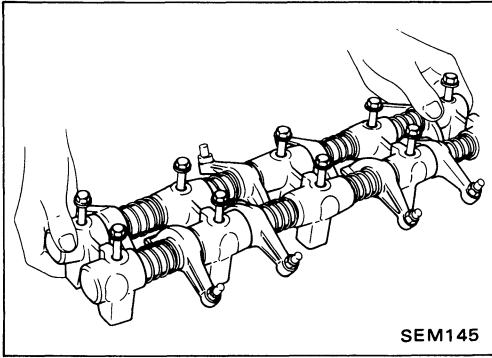

SEM145

1. Remove intake manifold with injection body and exhaust manifold.
2. Remove rocker shaft assembly together with securing bolts.
 - a. **Do not remove bolts at No. 1 and No. 5 brackets since rocker shaft bracket and rocker will spring out.**
 - b. **When loosening bolts, evenly loosen from outside in sequence.**
3. Remove camshaft.

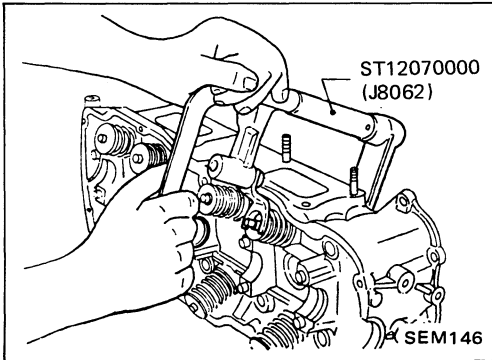

SEM146

4. Remove valves, valve springs and relating parts using Tool. **Keep the disassembled parts in order.**

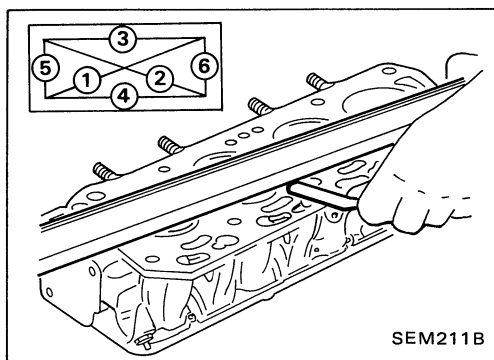

CYLINDER HEAD DISTORTION

Cylinder head distortion:

Less than 0.1 mm (0.004 in)

If beyond the specified limit, replace it or resurface it.

Resurfacing limit:

The resurfacing limit of cylinder head is determined by the cylinder block resurfacing in an engine.

Amount of cylinder head resurfacing is "A"

Amount of cylinder block resurfacing is "B"

The maximum limit is as follows:

$$A + B = 0.2 \text{ mm (0.008 in)}$$

After resurfacing the cylinder head, check that camshaft rotates freely by hand. If resistance is felt, the cylinder head must be replaced.

Cylinder head height (Nominal):

98.9±0.2 mm (3.894±0.008 in)

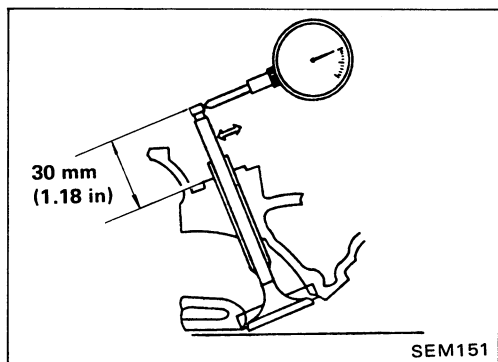

VALVE GUIDE CLEARANCE

- Valve guide clearance should be measured parallel with rocker arm. (Generally, a large amount of wear occurs in this direction.)

Stem to guide clearance:

Maximum limit

0.10 mm (0.0039 in)

Maximum allowable deflection

(Dial indicator reading)

0.2 mm (0.008 in)

- To determine the correct replacement part, measure valve stem diameter and valve guide bore.

For dimensions, refer to S.D.S.

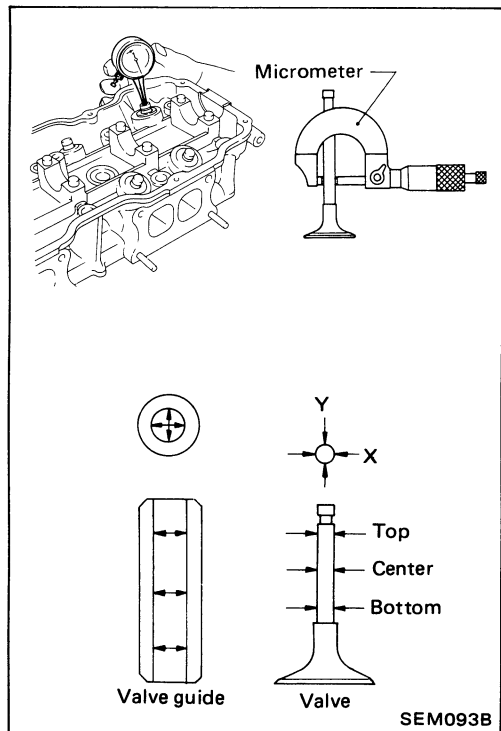

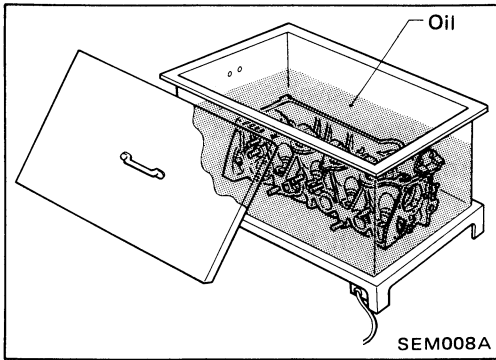

VALVE GUIDE REPLACEMENT

1. To remove valve guide, heat cylinder head to 150 to 160°C (302 to 320°F).

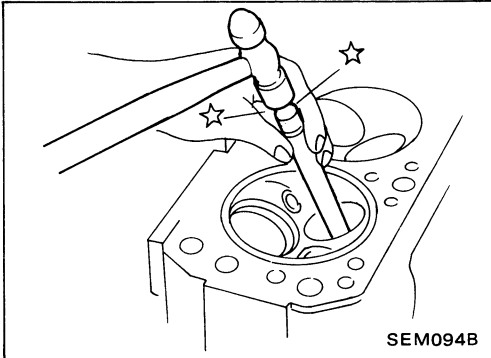

2. Drive out valve guide with a press [under a 20 kN (2t, 2.2 US ton, 2.0 Imp ton) pressure] or hammer, and suitable tool.

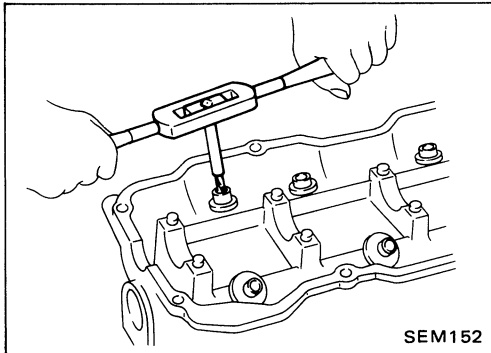

3. Ream cylinder head valve guide hole.
Valve guide hole inner diameter
(For service parts): mm (in)
12.185 - 12.196 (0.4797 - 0.4802)

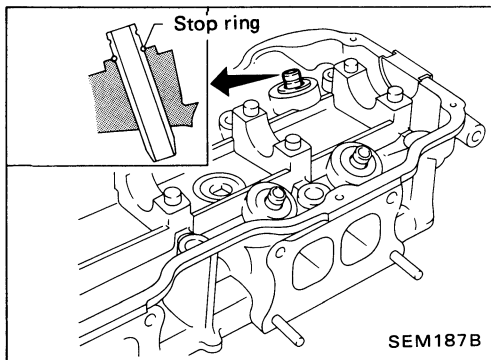

4. Heat cylinder head to 150 to 160°C (302 to 320°F) and press service valve guide onto cylinder head.

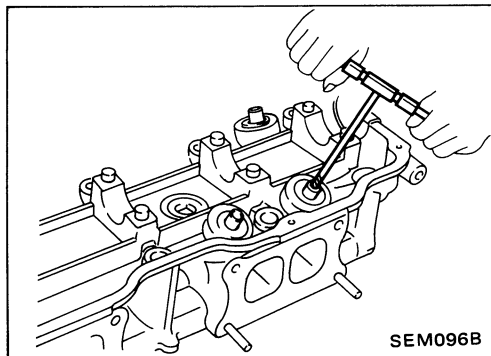

5. Ream valve guide.
Finished size:
8.000 - 8.018 mm (0.3150 - 0.3157 in)

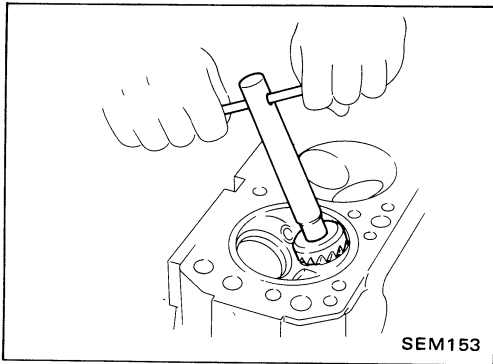

VALVE SEATS

Check valve for any evidence of pitting at valve contact surface, and reseat or replace if worn out excessively.

- When repairing valve seats, check valve and valve guide for wear beforehand. If worn, replace them. Then correct valve seat.
- The cutting should be done with both hands for uniform cutting.

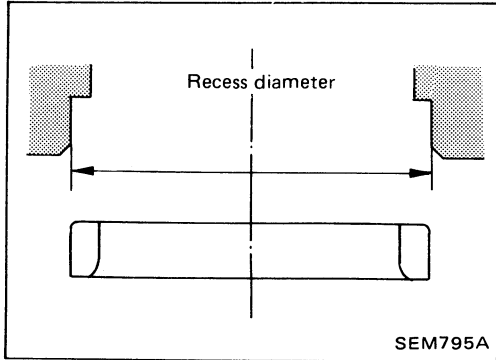

REPLACING VALVE SEAT FOR SERVICE PARTS

1. Bore out old seat until it collapses. The machine depth stop should be set so that boring cannot continue beyond the bottom face of the seat recess in cylinder head.
2. Ream cylinder head recess.

Reaming bore for service valve seat

[Oversize 0.5 mm (0.020 in)] :

Intake

45.500 - 45.516 mm (1.7913 - 1.7920 in)

Exhaust

40.500 - 40.516 mm (1.5945 - 1.5951 in)

Reaming should be done to the concentric circles to valve guide center so that valve seat will have the correct fit.

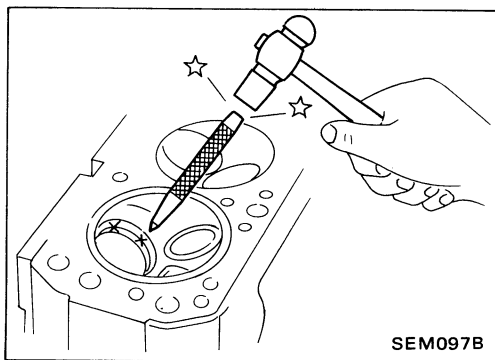

3. Heat cylinder head to a temperature of 150 to 160°C (302 to 320°F).
4. Press fit insert until it seats on the bottom, and caulk more than 4 points.

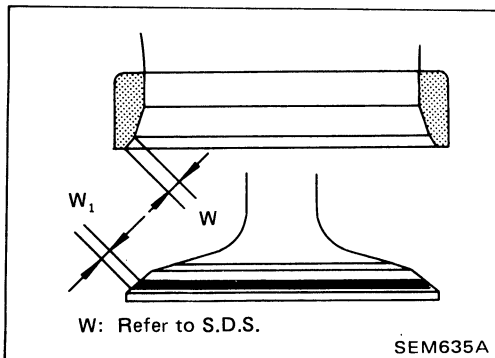

5. Cut or grind valve seat using suitable tool at the specified dimensions as shown in S.D.S.
6. After cutting, lap valve seat with a lapping compound.
7. Check contact condition of valve seat.

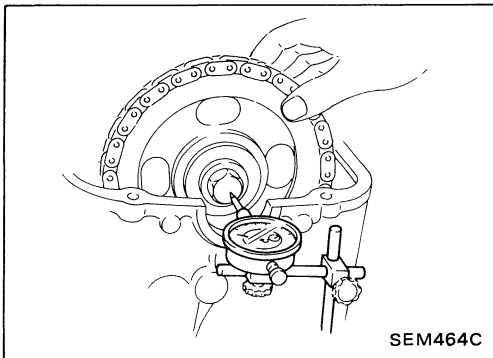

CAMSHAFT VISUAL CHECK

Check camshaft for scratches, seizure and wear.

CAMSHAFT END PLAY

1. Install camshaft and locate plate in cylinder head.
2. Measure camshaft end play.

Camshaft end play:

Limit 0.2 mm (0.008 in)

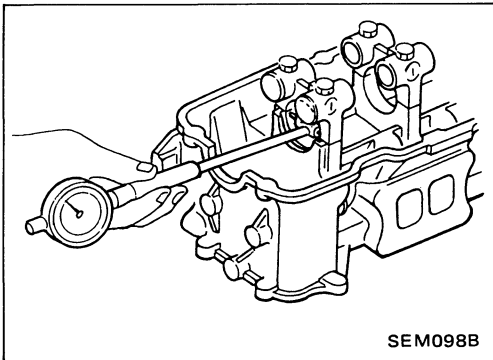

CAMSHAFT JOURNAL CLEARANCE

1. Measure the inside diameter of camshaft bearing.

Standard inner diameter:

33.000 - 33.025 mm (1.2992 - 1.3002 in)

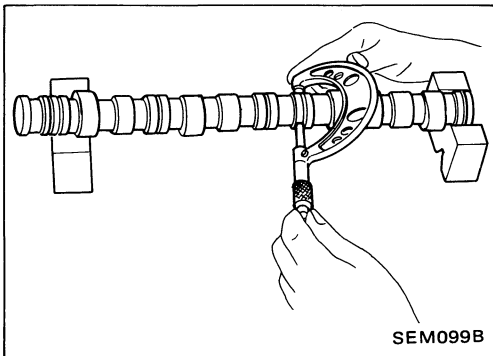

2. Measure the outside diameter of camshaft journal.

Standard outer diameter:

32.920 - 32.940 mm (1.2961 - 1.2968 in)

If the clearance is greater than the maximum, replace camshaft and/or cylinder head.

Maximum clearance:

0.12 mm (0.0047 in)

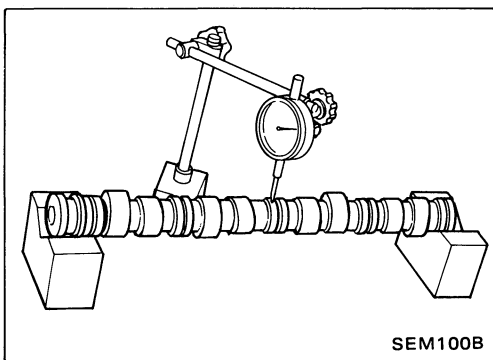

CAMSHAFT RUNOUT

Runout [T.I.R. (Total Indicator Reading)]:

Limit 0.02 mm (0.0008 in)

at the center journal

If beyond the limit, replace.

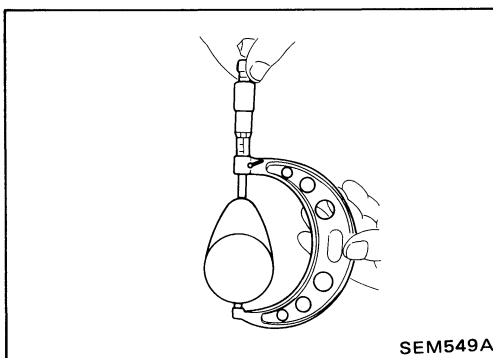

CAMSHAFT CAM HEIGHT

Standard cam height:

Intake

38.477 - 38.527 mm (1.5148 - 1.5168 in)

Exhaust

38.481 - 38.531 mm (1.5150 - 1.5170 in)

Cam wear:

Limit 0.25 mm (0.0098 in)

If wear is beyond the limit, replace.

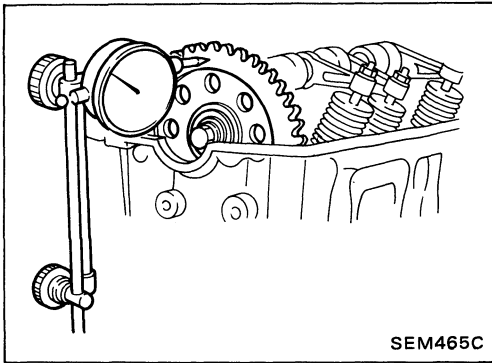

CAMSHAFT SPROCKET RUNOUT

Install sprocket on camshaft and check for runout.

If runout exceeds the specified limit, replace camshaft sprocket.

Runout (Total indicator reading):

Limit 0.1 mm (0.004 in)

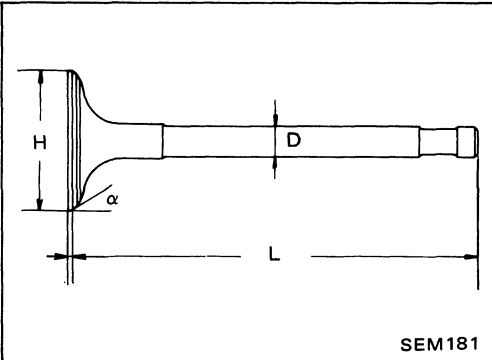

VALVE DIMENSIONS

Check dimensions in each valve. For dimensions, refer to S.D.S.

When valve head has been worn down to 0.5 mm (0.020 in) in margin thickness, replace the valve.

Grinding allowance for valve stem tip is 0.2 mm (0.008 in) or less.

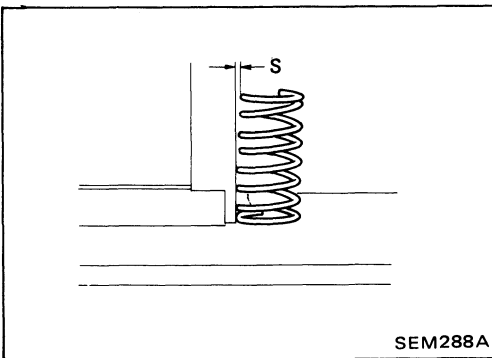

VALVE SPRING SQUARENESS

Out-of-square "S" mm (in):

Outer

Less than 2.2 (0.087)

Inner

Less than 1.9 (0.075)

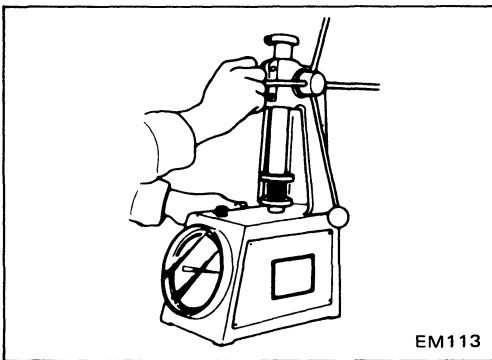

VALVE SPRING PRESSURE LOAD

Refer to S.D.S.

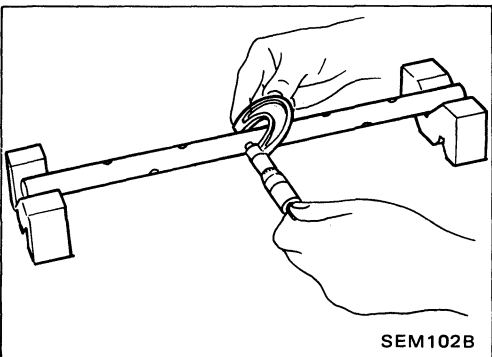

ROCKER SHAFT AND ROCKER ARM

1. Check rocker shafts and rocker arms for scratches, seizure and wear.

2. Check outer diameter of rocker shaft.

Diameter mm (in):

19.979 - 20.000 (0.7866 - 0.7874)

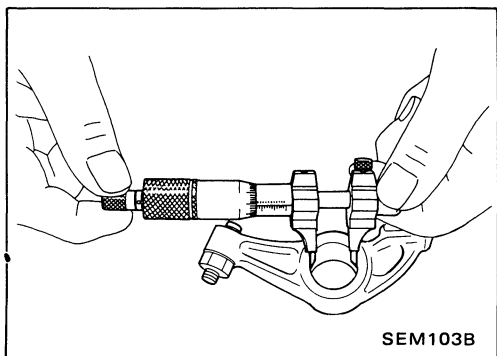

3. Check inner diameter of rocker arm.

Diameter mm (in):

20.007 - 20.028 (0.7877 - 0.7885)

Rocker arm to shaft clearance mm (in):

0.007 - 0.049 (0.0003 - 0.0019)

- Discard old oil seal and install new one.
- Apply a coat of engine oil to sealing lips of oil seal and frictional surfaces of moving parts.

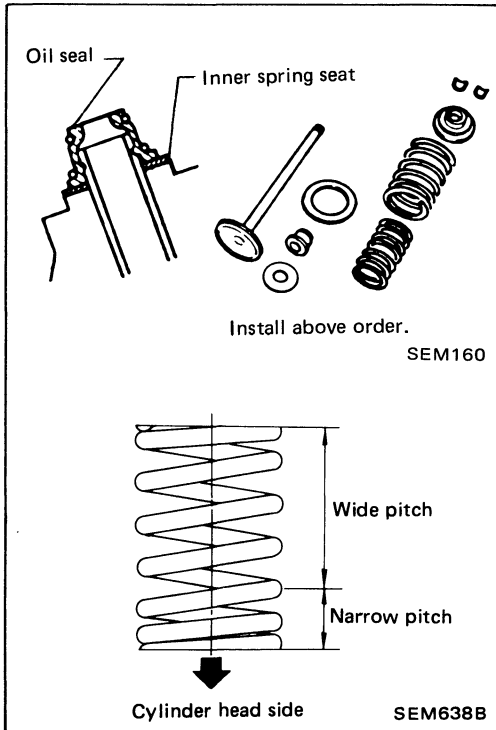

1. Install valve component parts.
 - Before installing valve oil seal, install inner valve spring seat.
 - Install outer valve spring (uneven pitch type) with its narrow pitch side toward cylinder head side.

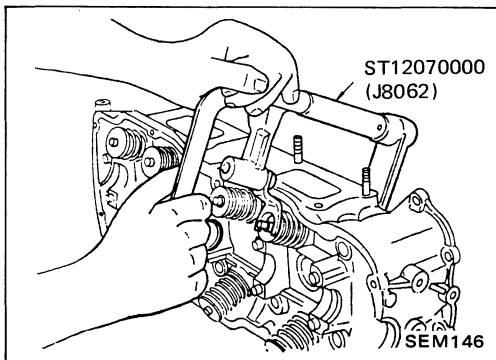
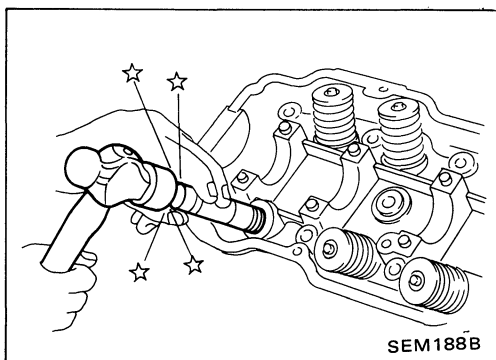

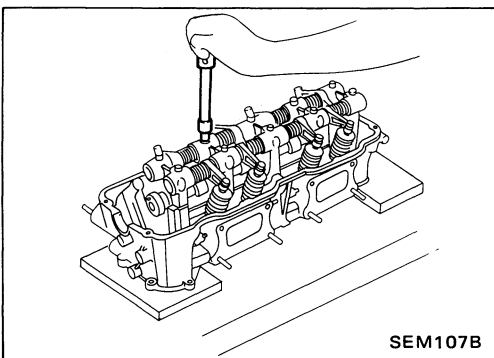
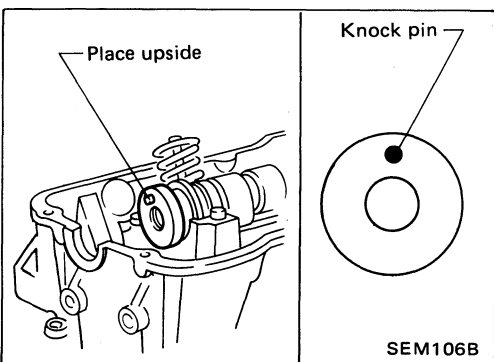
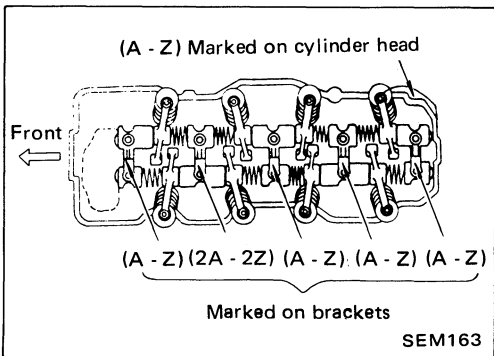
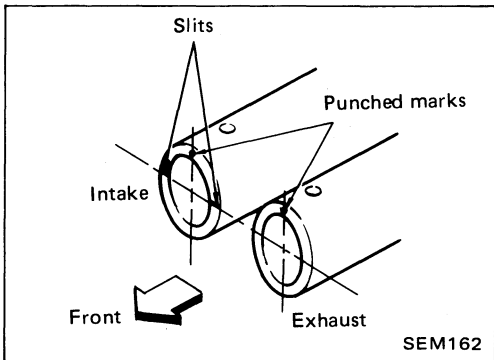
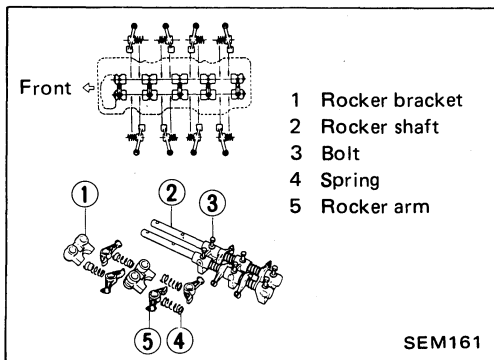

2. Install rocker shaft bracket, valve rocker, and spring on valve rocker shaft, observing the following.

- (1) Intake rocker shaft has identification mark (slit on front surface), but exhaust rocker shaft does not.
- (2) Both rocker shafts should be assembled so that punched marks on front surfaces come to upside. Marks are used to identify oil hole direction.

- (3) No. 1 and No. 3 cylinder's intake and exhaust valve rockers are same parts, and provide identification mark "1". Similarly, the one for No. 2 and No. 4 cylinder provides mark "2".
- (4) Be careful not to miss original location of rocker shaft brackets. For this purpose, the same alphabetical identification marks are provided on each bracket and cylinder head.

To prevent rocker shaft brackets from slipping out of rocker shafts, insert bracket bolts (any bolt will do) into bolt holes of No. 1 and No. 5 rocker shaft bracket.

3. Mount camshaft onto cylinder head, placing knock pin at front end to top position.

Apply engine oil to camshaft when mounting onto cylinder head.

4. Mount valve rocker shaft assembly on cylinder head by accommodating to knock pin of the head. Then, tighten to the specified torque.

 : **Rocker shaft bracket bolt**
 15 - 25 N·m
 (1.5 - 2.5 kg·m, 11 - 18 ft·lb)

- Tighten bolts gradually, in two to three stages outwardly from center bracket.
- When tightening bolts, make space under cylinder head since some valves will open and interfered.

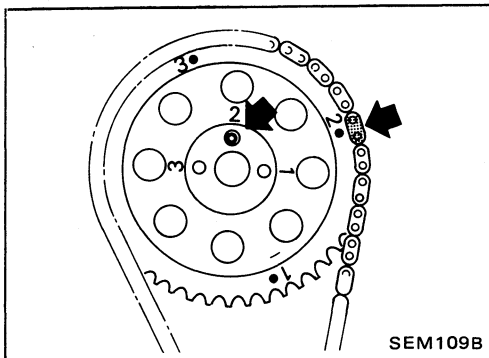
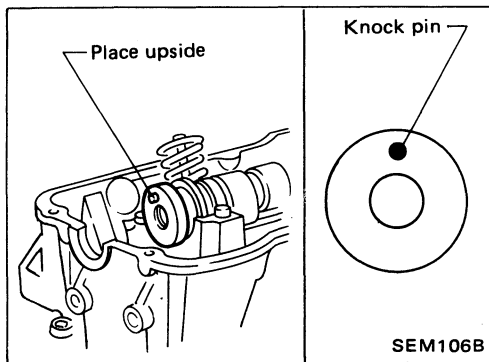
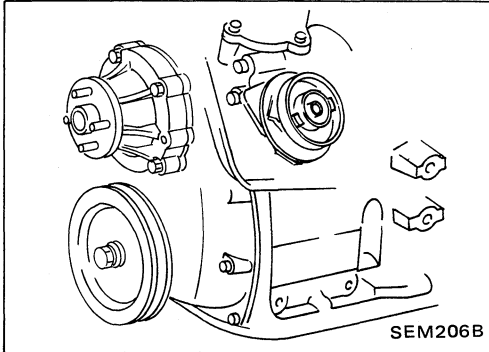
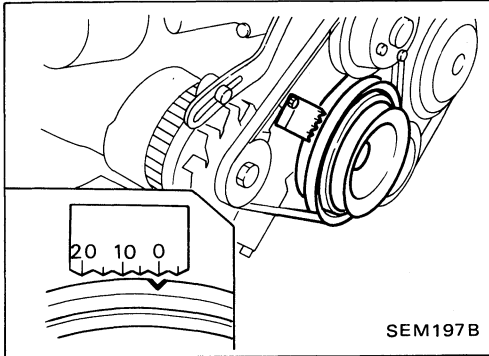
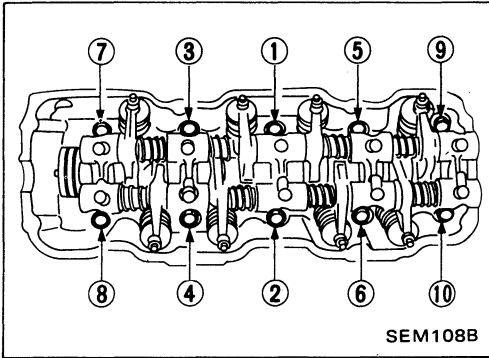

1. Install cylinder head with new gasket and tighten cylinder head bolts.

- Tightening procedure

- 1st Tighten all bolts to 29 N·m (3.0 kg-m, 22 ft-lb).
- 2nd Tighten all bolts to 78 N·m (8.0 kg-m, 58 ft-lb)
- 3rd Loosen all bolts completely.
- 4th Tighten all bolts to 29 N·m (3.0 kg-m, 22 ft-lb).
- 5th Tighten all bolts to 74 to 83 N·m (7.5 to 8.5 kg-m, 54 to 61 ft-lb) or if you have an angle wrench, turn all bolts 90 to 95 degrees clockwise.

2. Confirm that No. 1 cylinder is set at T.D.C. on its compression stroke.

3. Ensure that front knock pin is positioned at upper surface of camshaft.

4. Set chain on camshaft sprocket by aligning each mating mark. Then install camshaft sprocket to camshaft.

- Camshaft sprocket should be installed by fitting the knock pin of camshaft into its No. 2 hole. And No. 2 timing mark must also be used.

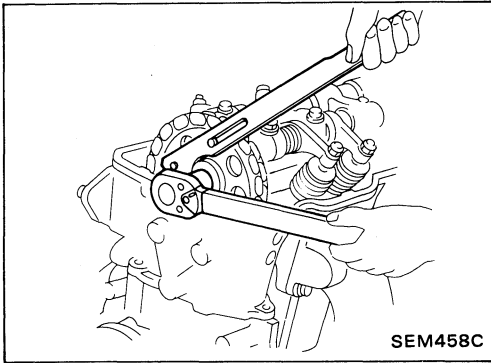

- ☐ : Camshaft sprocket bolt
 118 - 157 N·m
 (12 - 16 kg·m, 87 - 116 ft·lb)

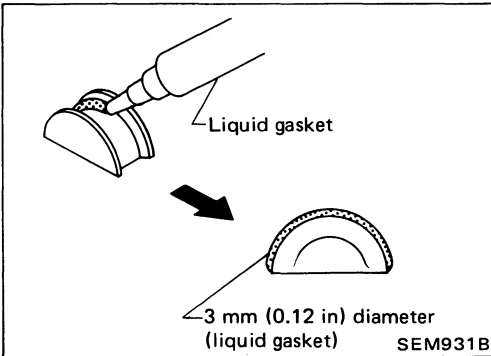

5. Install rubber plugs as follows:
 - (1) Apply liquid gasket to rubber plugs.
 - Rubber plugs should be replaced with rocker cover gasket.
 - Rubber plugs should be installed within 5 minutes of applying liquid gasket.

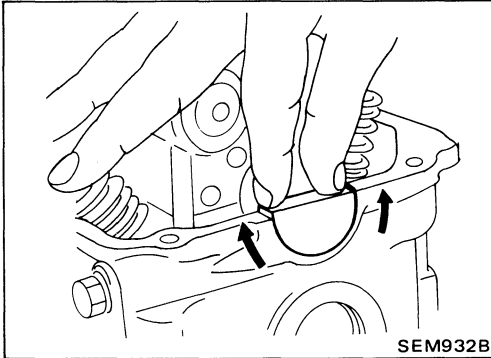

- (2) Install rubber plugs, then move them with your fingers to uniformly spread the gasket on cylinder head surface.
 - Rubber plugs should be installed flush with the surface.
 - Do not start the engine for 30 minutes after installing rocker cover.

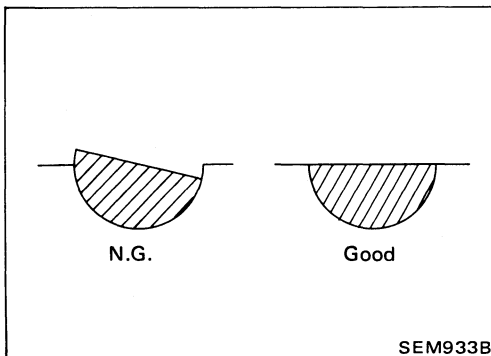

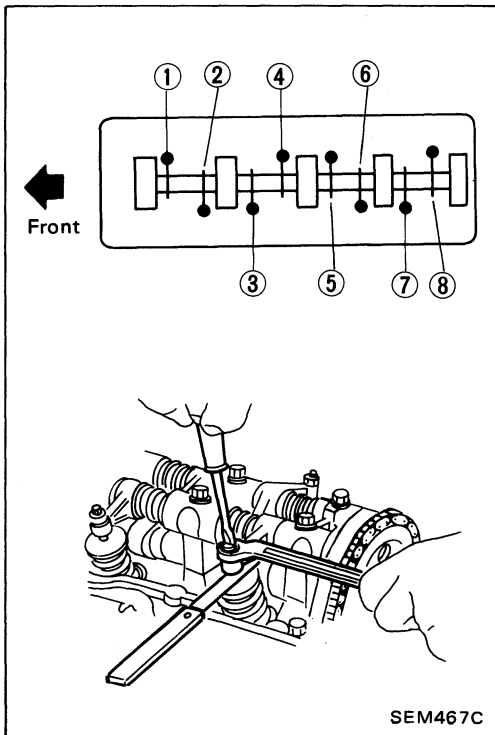

6. Adjust valve clearance.

- (1) Set No. 1 cylinder to top dead center on its compression stroke, and adjust valve clearance ①, ②, ④ and ⑥.
- (2) Again, rotate crankshaft one turn so that No. 4 cylinder is at top dead center of its compression stroke, and adjust valve clearance ③, ⑤, ⑦ and ⑧.

Valve clearance:

Unit: mm (in)

	COLD*	HOT
Intake	0.21 (0.008)	0.3 (0.012)
Exhaust	0.23 (0.009)	0.3 (0.012)

*: At a temperature of approximately 20°C (68°F)

Adjusting screw lock nuts:

 : 16 - 22 N·m (1.6 - 2.2 kg·m, 12 - 16 ft·lb)

7. Install the following parts.

- Rocker cover
- Power steering pump, idler pulley and brackets.
- Power steering pump drive belt

8. Connect exhaust manifold and exhaust tube.

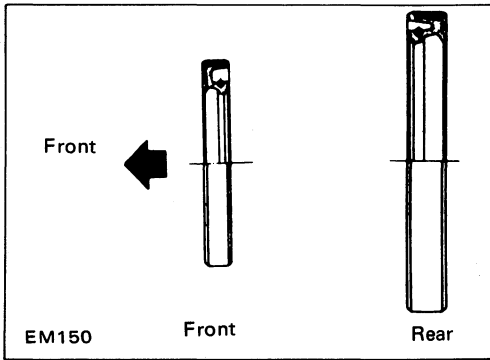

OIL SEAL INSTALLING DIRECTION

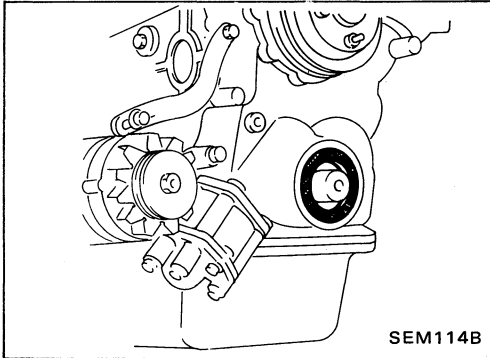

CRANKSHAFT FRONT OIL SEAL

1. Remove the following parts.
 - Cooling fan
 - Radiator shroud
 - Crankshaft pulley
2. Remove oil seal. Be careful not to damage surface of crankshaft.

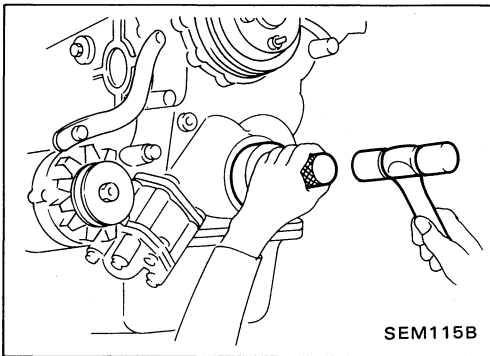

3. Apply engine oil to oil seal and install it in place using suitable tool.
4. Install the following parts.
 - Crankshaft pulley
 - Cooling fan
 - Radiator shroud

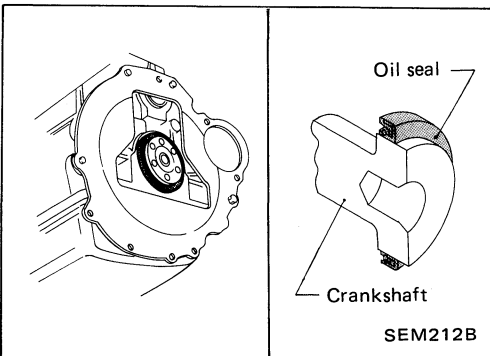

CRANKSHAFT REAR OIL SEAL

1. Remove transmission. (Refer to MT or AT section.)
2. Remove flywheel. Remove oil seal using a suitable tool. Be careful not to damage surface of crankshaft.

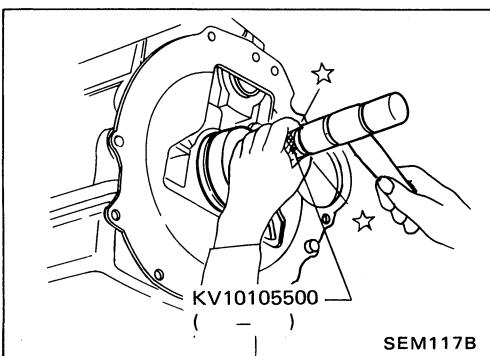

3. Apply engine oil to oil seal and install it in place using suitable tool.
4. Install transmission. (Refer to MT or AT section.)

VALVE OIL SEAL

1. Remove rocker cover.
2. Remove rocker arm and rocker shaft assembly.
3. Remove all spark plugs.

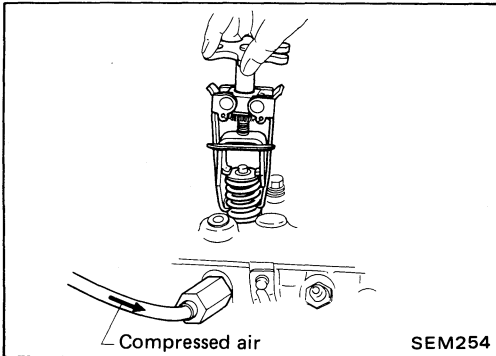

4. Install air hose adapter into spark plug hole and apply air pressure to hold valves in place [Apply pressure of 490 kPa (5 kg/cm² , 71 psi)].

When performing this operation piston should be set at T.D.C.

5. Remove valve spring and valve oil seal.

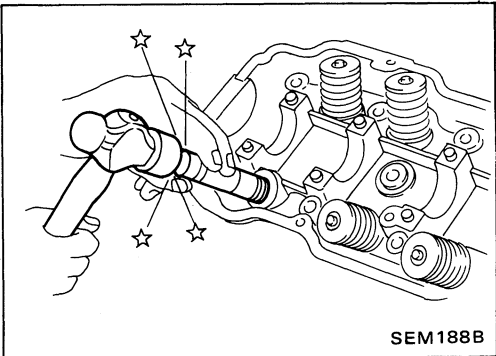

6. Apply engine oil to valve oil seal and install it in place.
Before installing valve oil seal, install inner valve spring seat.

7. Install parts in the reverse order of removal.

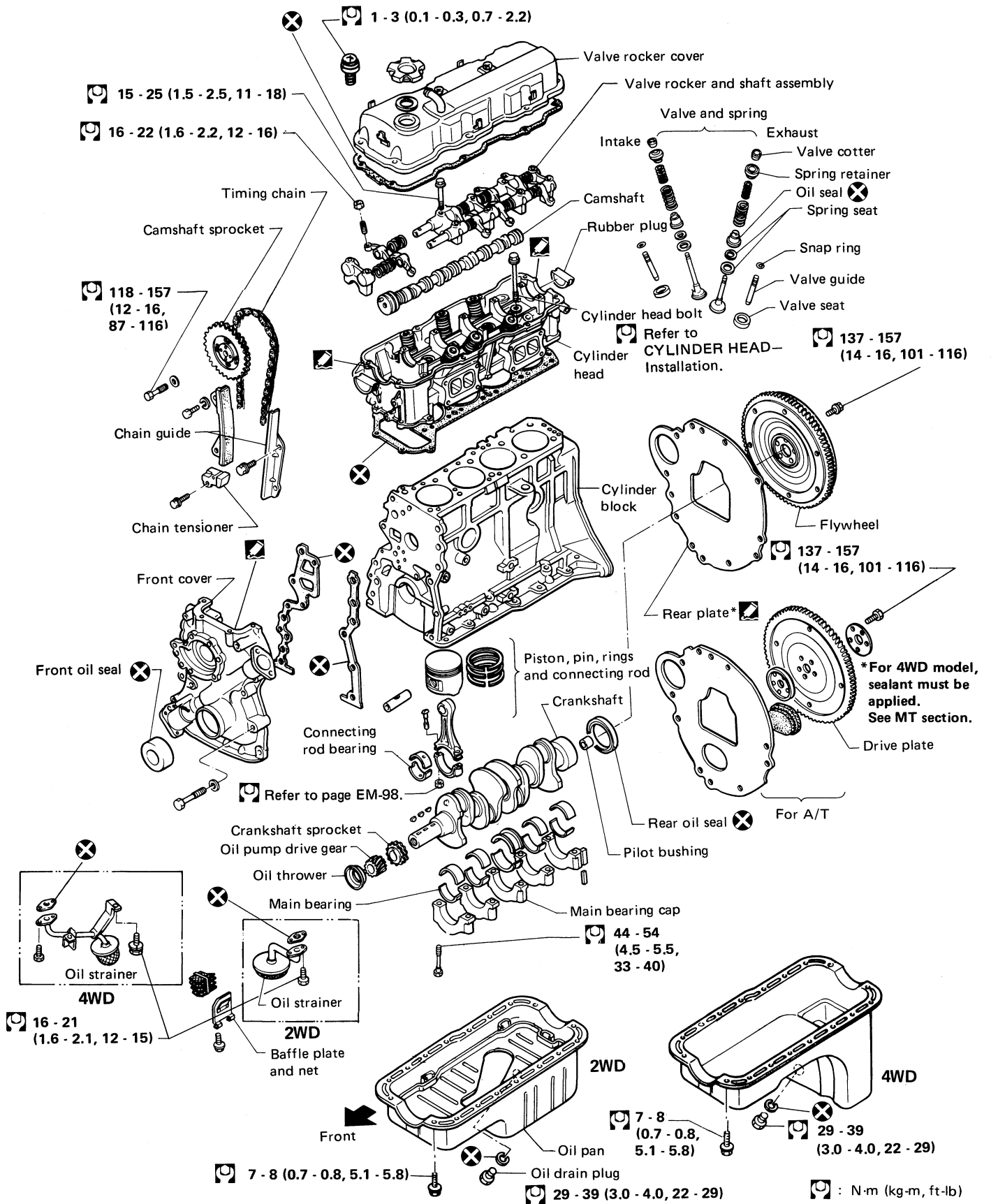

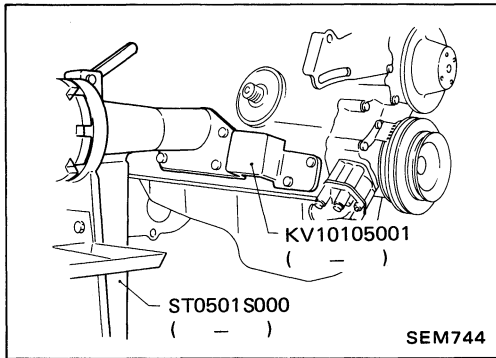

PISTON AND CRANKSHAFT

1. Place engine on work stand.

2. Drain coolant and oil.
3. Remove water pump.
4. Remove oil pan and oil pump.
5. Remove cylinder heads.
6. Remove pistons.

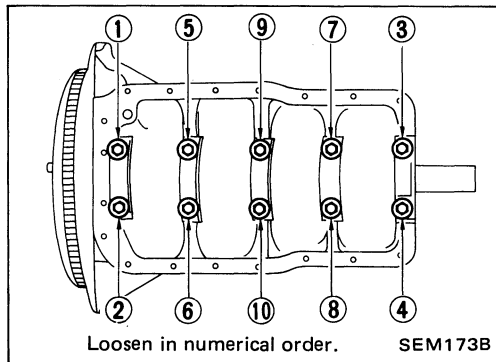

7. Remove bearing cap and crankshaft.

Place the bearings and caps in their proper order.

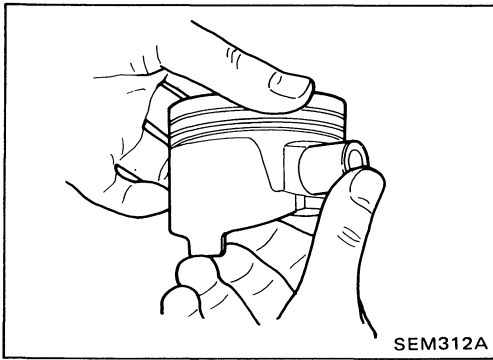

PISTON AND PISTON PIN CLEARANCE

- Confirm the fitting of piston pin into piston pin hole to such an extent that it can be pressed smoothly by finger at room temperature.

Piston pin to piston clearance:

0.008 - 0.012 mm (0.0003 - 0.0005 in)

Apply engine oil to piston pin.

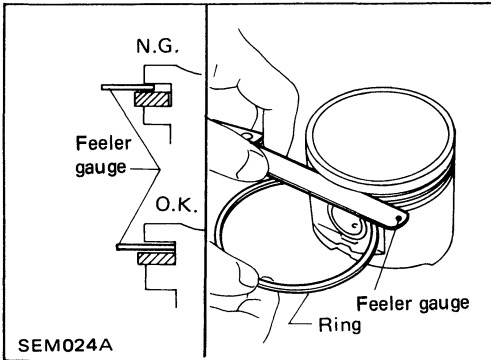

PISTON RING SIDE CLEARANCE

Side clearance:

Top ring

0.040 - 0.073 mm (0.0016 - 0.0029 in)

2nd ring

0.030 - 0.063 mm (0.0012 - 0.0025 in)

Max. limit of side clearance (Top and 2nd rings):

0.1 mm (0.004 in)

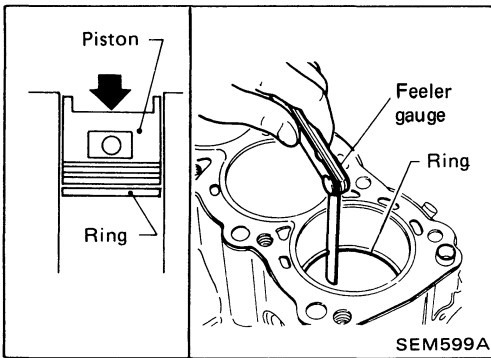

PISTON RING GAP

Standard ring gap mm (in):

Top ring

0.28 - 0.38 (0.0110 - 0.0150)

2nd ring

0.25 - 0.35 (0.0098 - 0.0138)

Oil ring

0.20 - 0.60 (0.0079 - 0.0236)

Max. limit of ring gap mm (in):

0.5 (0.020)

BEARING CLEARANCE

Bearing clearance mm (in):

Main bearing

No. 1 and No. 5 bearings

0.020 - 0.062 (0.0008 - 0.0024)

No. 2, No. 3 and No. 4 bearings

0.020 - 0.075 (0.0008 - 0.0030)

Limit 0.12 (0.0047)

Connecting rod bearing

0.012 - 0.054 (0.0005 - 0.0021)

Limit 0.12 (0.0047)

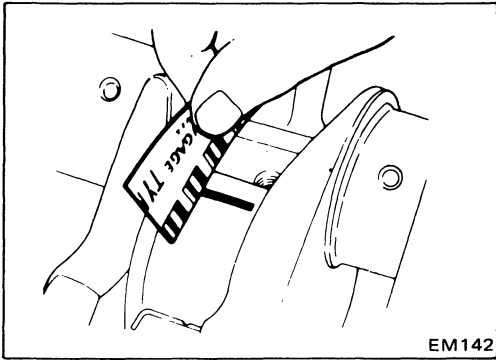

Method A (Using plastigage)

CAUTION:

- Do not turn crankshaft or connecting rod while the plastigage is being inserted.
- When bearing clearance exceeds the specified limit, ensure that the proper bearing has been installed. Then if excessive bearing clearance exists, use thicker main bearing or under-sized bearing so that the specified bearing clearance is obtained.

Method B (Using dial gauge & micrometer)

Main bearing

1. Install main bearings to cylinder block and main bearing cap.
2. Install main bearing cap to cylinder block.

Tighten all bolts in correct order and in two or three stages.

 : 44 - 54 N·m
(4.5 - 5.5 kg·m, 33 - 40 ft·lb)

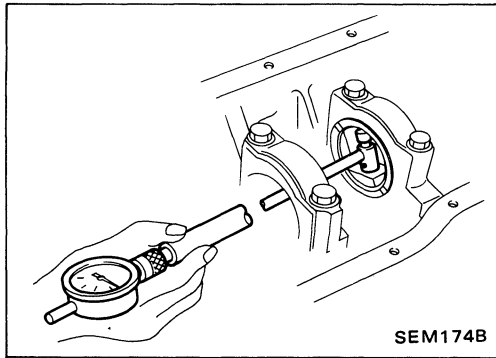

3. Measure inside diameter "A" of main journal.

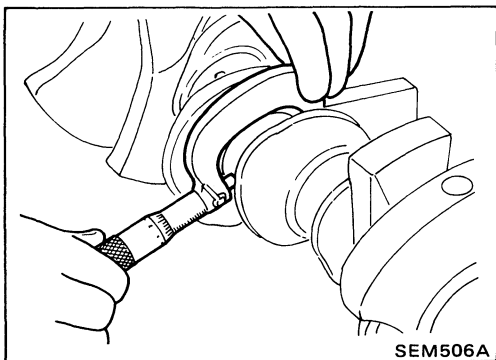

4. Measure outside diameter "Dm" of main journal in crankshaft.
5. Calculate main bearing clearance.
Main bearing clearance = A - Dm

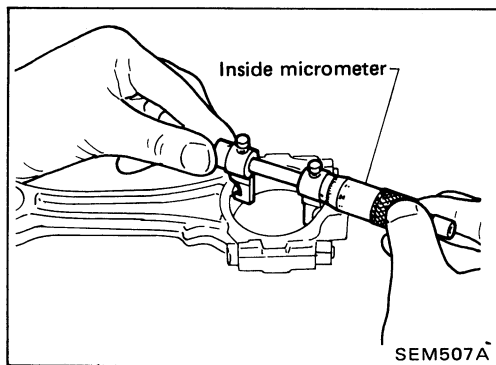

Connecting rod bearing

1. Install connecting rod bearing to connecting rod and cap.
2. Install connecting rod cap to connecting rod.

Apply engine oil to the thread portion of bolts and seating surface of nuts.

 : 44 - 54 N·m
(4.5 - 5.5 kg·m, 33 - 40 ft·lb)

3. Measure inside diameter "C" of bearing.
4. Measure outside diameter "Dp" of pin journal in crankshaft.
5. Calculate connecting rod bearing clearance.
Connecting rod bearing clearance = C – Dp

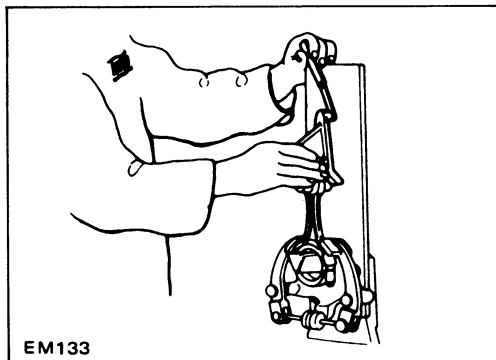

CONNECTING ROD BEND AND TORSION

Bend and torsion:

Limit 0.05 mm (0.0020 in)
per 100 mm (3.94 in) length

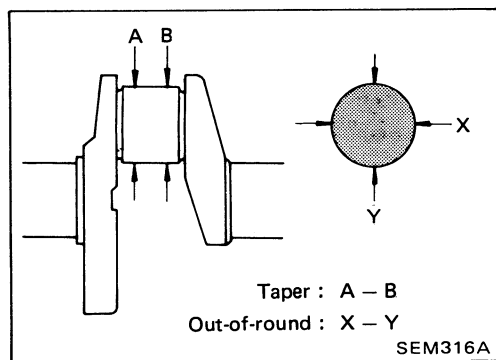

CRANKSHAFT

1. Check crankshaft journals for score, bias, wear or cracks. If faults are minor, correct with fine crocus cloth.
2. Check journals with a micrometer for taper and out-of-round.

Out-of-round (X-Y):

Less than 0.01 mm (0.0004 in)

Taper (A-B):

Less than 0.01 mm (0.0004 in)

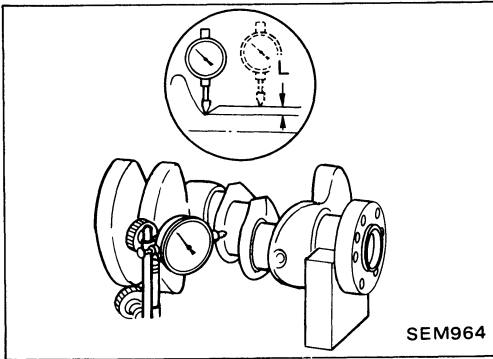

- a. When regrinding crank pin and crank journal, measure "L" dimension in fillet roll. Make sure the measurements exceed the specified limit. If the measurements are within the specified limit, do not regrind.
 - L: More than 0.1 mm (0.004 in)
- b. Do not grind off fillet roll.
- c. Refer to S.D.S. for regrinding crankshaft and available service parts.

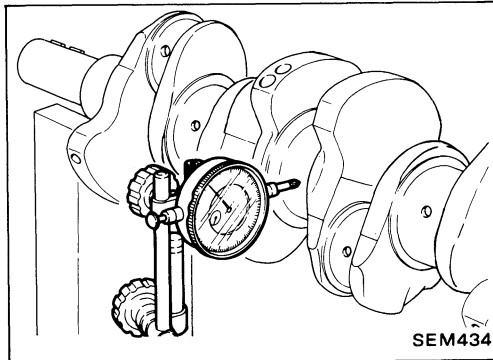

3. Check crankshaft runout.
 - Runout [T.I.R. (Total Indicator Reading)]:
 - Less than 0.05 mm (0.0020 in)

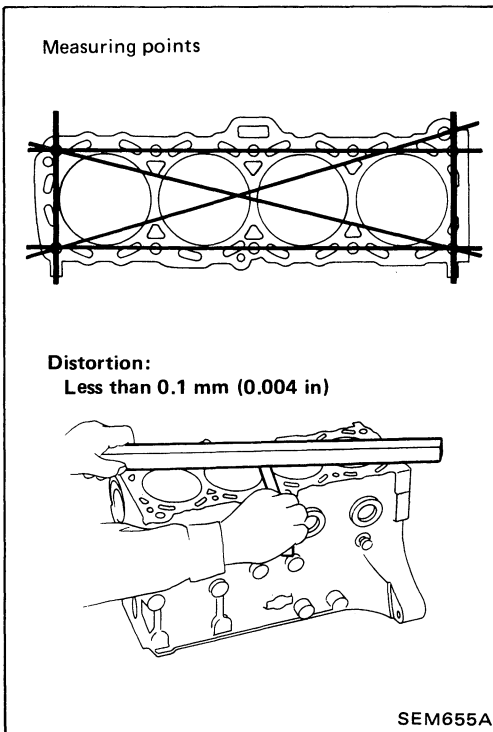

CYLINDER BLOCK DISTORTION AND WEAR

1. If beyond the specified limit, resurface it.
 - Resurfacing limit:
 - The resurfacing limit of cylinder block is determined by the cylinder head resurfacing in an engine.
 - Amount of cylinder head resurfacing is "A"
 - Amount of cylinder block resurfacing is "B"
 - The maximum limit is as follows:
 - $A + B = 0.2 \text{ mm (0.008 in)}$
 - Nominal cylinder block height from crank shaft center:
 - $247.00 \pm 0.05 \text{ mm (9.7244} \pm 0.0020 \text{ in)}$

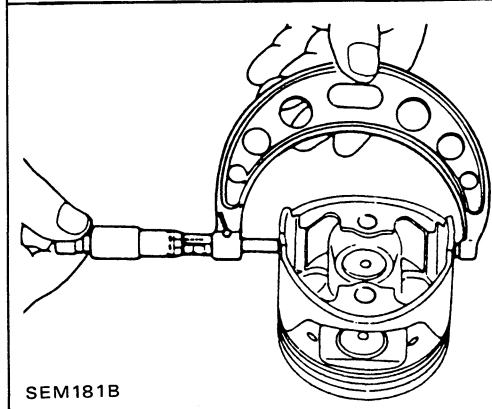
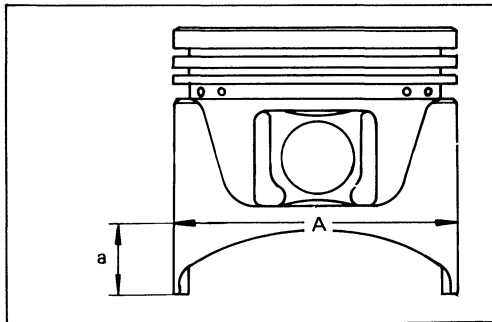
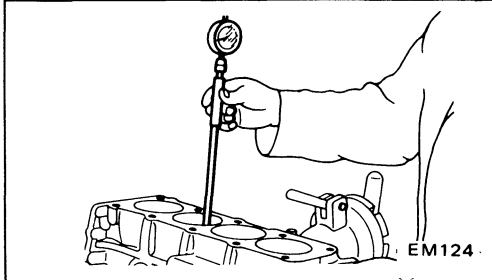
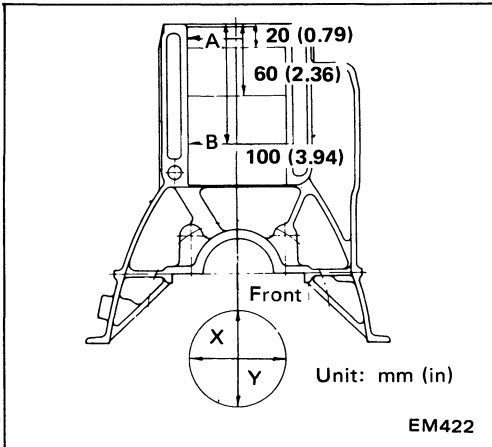

- Using a bore gauge, measure cylinder bore for wear, out-of-round or taper.

Standard inner diameter mm (in):
89.000 - 89.050 (3.5039 - 3.5059)

Refer to S.D.S.

Out-of-round (X-Y):
Limit 0.015 mm (0.0006 in)

Taper (A-B):
Limit 0.010 mm (0.0004 in)

- Check for scratches or seizure. If seizure is found, hone it.

CYLINDER BORING

When any cylinder needs boring, all other cylinders must also be bored.

- Determine piston oversize according to amount of cylinder wear.

Oversize pistons are available for service.

Refer to S.D.S.

- The size to which cylinders must be honed is determined by adding piston-to-cylinder clearance to the piston skirt diameter "A".

Dimension "a":
About 20 mm (0.79 in)

Rebored size calculation:

$$D = A + B - C = A + [0.005 \text{ to } 0.025 \text{ mm} \\ (0.0002 \text{ to } 0.0010 \text{ in})]$$

where,

D: Bored diameter

A: Skirt diameter as measured

B: Piston-to-wall clearance

C: Honing allowance 0.02 mm (0.0008 in)

- Install main bearing caps in place, and tighten to the specified torque to prevent distortion of the cylinder bores in final assembly.
- Cut cylinder bores.
 - Do not cut too much out of the cylinder bore at a time. Cut only 0.05 mm (0.0020 in) or so in diameter at a time.
- Hone the cylinders to the required size referring to S.D.S.
- Measure the finished cylinder bore for out-of-round and taper.
 - Measurement of a just machined cylinder bore requires utmost care since it is expanded by cutting heat.

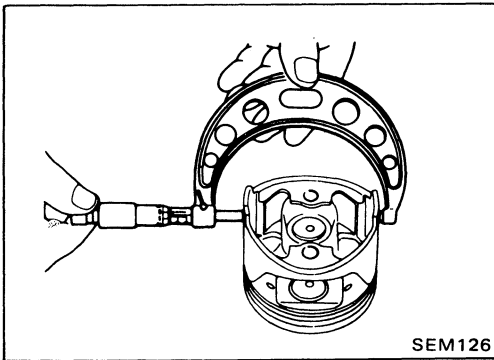

PISTON TO CYLINDER WALL CLEARANCE

Using micrometer

1. Measure piston and cylinder bore diameter.

Piston diameter "A":

Refer to S.D.S.

Measuring point "a":

20 mm (0.79 in)

2. Check that piston clearance is within the specification.

Piston clearance:

0.025 - 0.045 mm (0.0010 - 0.0018 in)

Using feeler gauge

When pulling feeler gauge straight upward, measure the extracting force. It is recommended that piston and cylinder be heated to 20°C (68°F).

Feeler gauge thickness:

0.04 mm (0.0016 in)

Extracting force:

2.0 - 14.7 N (0.2 - 1.5 kg, 0.4 - 3.3 lb)

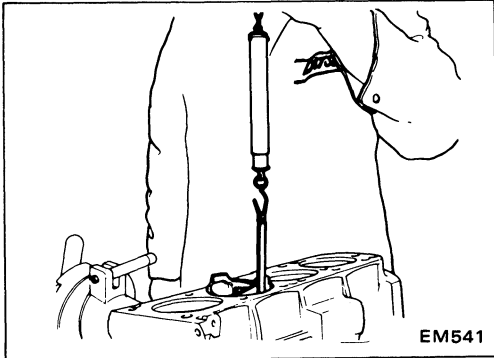

FLYWHEEL RUNOUT

Runout (Total indicator reading):

Less than 0.10 mm (0.0039 in)

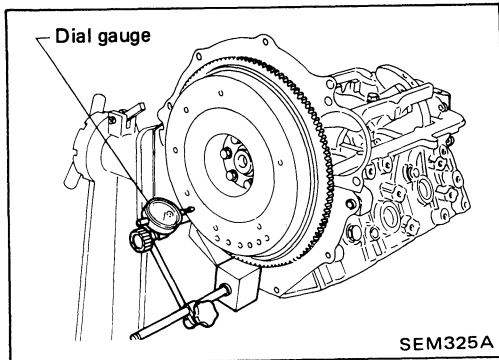

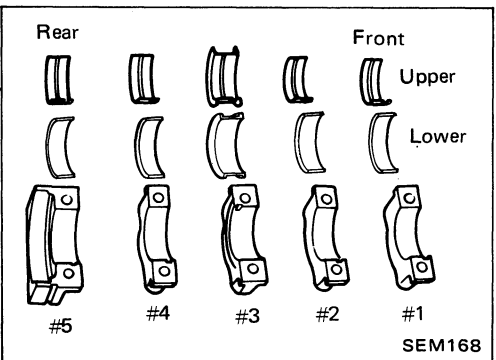
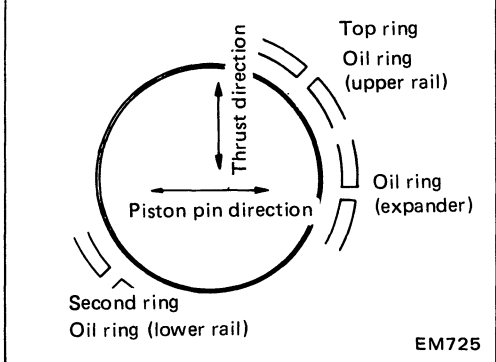
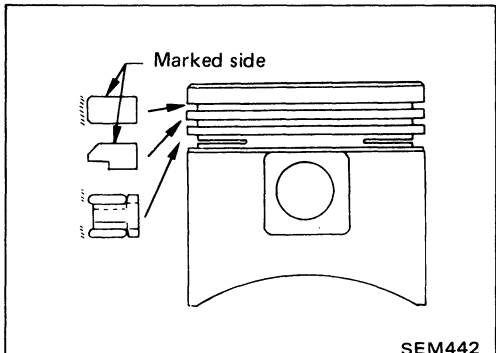
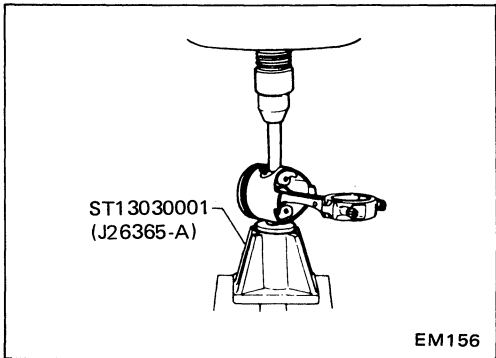
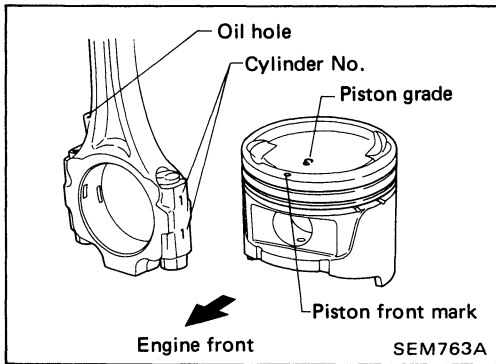

PISTON

- a. Numbers are stamped on the connecting rod and cap corresponding to each cylinder. Care should be taken to avoid a wrong combination including bearing.
- b. When pressing piston pin in connecting rod, apply engine oil to pin and small end of connecting rod.
- c. After assembling, ascertain that piston swings smoothly.

Install piston assembly.

Install so that stamped mark on ring faces upward.

- a. Top ring is barrel face type.
- b. Second ring is undercut type.
- c. In the combined oil ring, upper rail is the same as lower one.
- d. Apply engine oil to sliding parts.
- e. Arrange so that the front mark on piston head faces to the front of engine.

CRANKSHAFT

- 1. Set main bearings in the proper position on cylinder block. If either crankshaft, cylinder block or main bearing is reused again, it is necessary to measure main bearing clearance.
- a. Only center bearing (No. 3) is a flanged type.
- b. All inter-bearings (No. 2 and No. 4) are the same type.
- c. Front bearing (No. 1) is also the same type as rear bearing (No. 5).
- d. Upper and lower bearings are not interchangeable. Upper ones have oil groove.

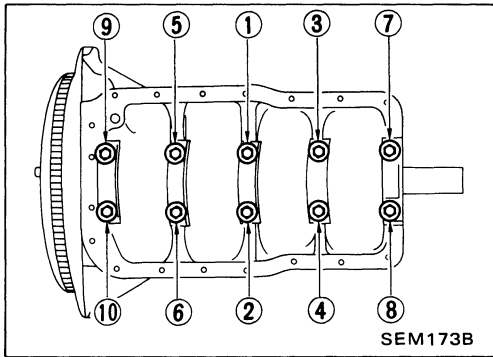

2. Apply engine oil to main bearing surfaces on both sides of cylinder block and cap.
3. Install crankshaft and main bearing caps and tighten bolts to the specified torque.

 : 44 - 54 N·m
(4.5 - 5.5 kg·m, 33 - 40 ft·lb)

- Tighten in two or three stages.
- After securing bearing cap bolts, ascertain that crankshaft turns smoothly by hand.

4. Make sure that there exists proper end play of crankshaft at center bearing.

Crankshaft free end play:

Standard
0.05 - 0.18 mm (0.0020 - 0.0071 in)

Limit
0.30 mm (0.0118 in)

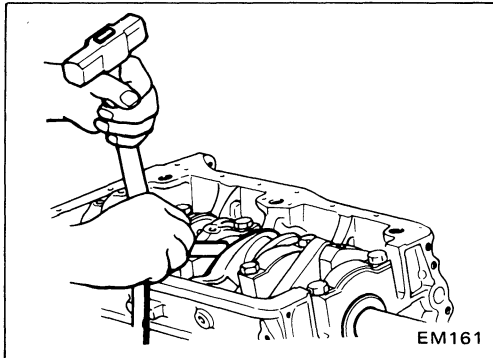

5. Measure connecting rod side clearance.

Connecting rod side clearance:

Standard
0.20 - 0.30 mm (0.0079 - 0.0118 in)

Limit
0.60 mm (0.0236 in)

If beyond the limit, replace connecting rod and/or crankshaft.

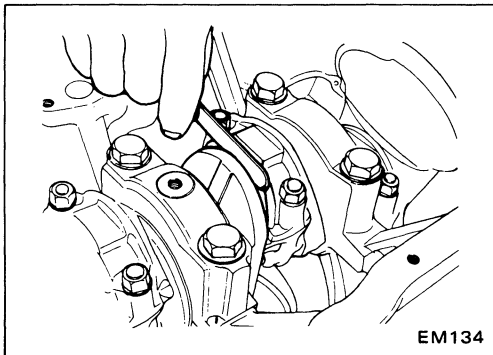

6. Install pistons with connecting rods.

- (1) Install them into corresponding cylinder using Tool.

- Be careful not to scratch cylinder wall with connecting rod.
- Apply engine oil to cylinder wall, piston and bearing.
- Arrange so that the front mark on piston head faces to the front of engine.

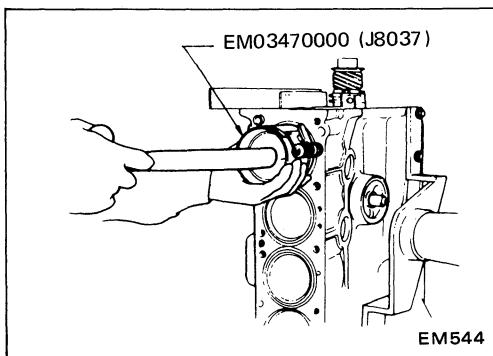

- (2) Install connecting rod bearing caps.

- a) Tighten bolts 14 to 16 N·m (1.4 to 1.6 kg·m, 10 to 12 ft·lb) and then turn bolts to 60 degree with an angle wrench.
- b) If angle wrench is not available, tighten bolts 38 to 44 N·m (3.9 to 4.5 kg·m, 28 to 33 ft·lb).

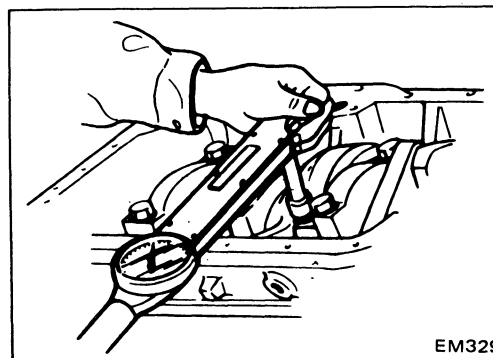

General Specifications

Cylinder arrangement	In-line-4
Displacement cm ³ (cu in)	2,389 (145.78)
Bore and Stroke mm (in)	89 x 96 (3.50 x 3.78)
Valve arrangement	O.H.C.
Firing order	1-3-4-2
Number of piston rings	
Compression	2
Oil	1
Number of main bearings	5
Compression ratio	8.3

Unit: kPa (kg/cm², psi)/rpm

Compression pressure	
Standard	1,196 (12.2, 173)/350
Minimum	902 (9.2, 131)/350
Differential limit between cylinders	98 (1.0, 14)/350

Inspection and Adjustment

CYLINDER HEAD

Unit: mm (in)

	Limit
Head distortion	0.1 (0.004)
Head height (Nominal)	98.9±0.2 (3.894±0.008)

VALVE

Unit: mm (in)

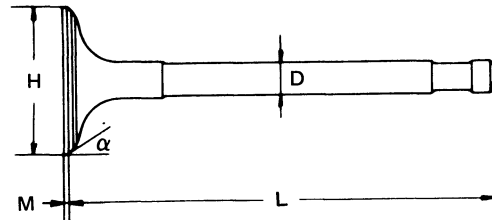

SEM181

		Standard	Limit
Valve head diameter "H"	In.	42.0 - 42.2 (1.654 - 1.661)	—
	Ex.	38.0 - 38.2 (1.496 - 1.504)	—
Valve length "L"	In.	122.8 - 123.1 (4.835 - 4.846)	—
	Ex.	123.6 - 123.9 (4.866 - 4.878)	—
Valve stem diameter "D"	In.	7.965 - 7.980 (0.3136 - 0.3142)	—
	Ex.	7.945 - 7.960 (0.3128 - 0.3134)	—
Valve face angle "α"	In.	45° 30' ± 15'	—
	Ex.		
Valve head margin "M"	In.	1.3 (0.051)	0.5 (0.020)
	Ex.	1.5 (0.059)	0.5 (0.020)
Grinding of valve stem end	In.	—	0.2 (0.008)
	Ex.	—	

Inspection and Adjustment (Cont'd)

Valve clearance

Unit: mm (in)

	*Cold	Hot
Intake	0.21 (0.008)	0.30 (0.012)
Exhaust	0.23 (0.009)	0.30 (0.012)

*: At a temperature of approximately 20°C (68°F)

Whenever valve clearances are adjusted to cold specifications, check that the clearances satisfy hot specifications and adjust again if necessary.

Valve spring

Unit: mm (in)

		Standard	Limit
Free height	Outer	49.77 (1.9594)	—
	Inner	44.10 (1.7362)	—
Assembled height/tension	Outer	40.0/225.6 (23.0), (1.575/50.7)	40.0/210.9 (21.5), (1.575/47.4)
	Inner	35.0/107.9 (11.0), (1.378/24.3)	35.0/99.1 (10.1), (1.378/22.3)
Out-of-square	Outer	—	2.2 (0.087)
	Inner	—	1.9 (0.075)

Valve guide

Unit: mm (in)

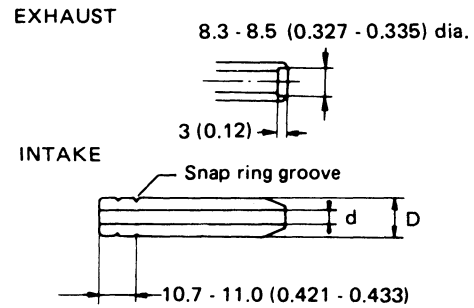

SEM175

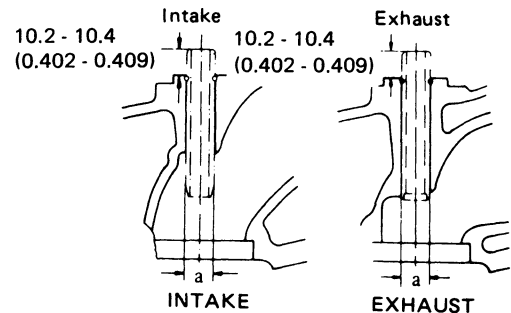

EM116

		Standard	Service
Valve guide	Outer diameter "D"	12.023 - 12.034 (0.4733 - 0.4738)	12.223 - 12.234 (0.4812 - 0.4817)
Valve guide	Inner diameter "d" [Finished size]	8.000 - 8.018 (0.3150 - 0.3157)	
Cylinder head valve	guide hole diameter "a"	11.985 - 11.996 (0.4718 - 0.4723)	12.185 - 12.196 (0.4797 - 0.4802)
Interference fit of valve	guide	0.027 - 0.049 (0.0011 - 0.0019)	
Valve stem to	guide	Standard	Limit
		In.	0.020 - 0.053 (0.0008 - 0.0021)
Ex.	0.040 - 0.073 (0.0016 - 0.0029)		
Stem end deflection		—	0.2 (0.008)

Inspection and Adjustment (Cont'd)

Valve seat

Seat insert dimensions

"Intake"

Unit: mm (in)

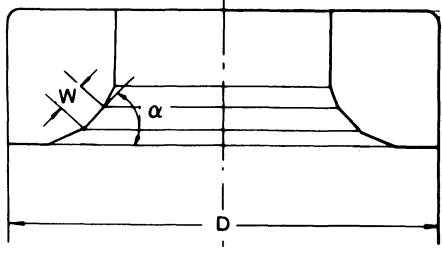
Profile		SEM177
Contacting face angle "α"	45°	
Contacting width "W" Standard	1.9 - 2.1 (0.075 - 0.083)	
Outer diameter "D" Standard	45.097 - 45.113 (1.7755 - 1.7761)	
Service	45.597 - 45.613 (1.7952 - 1.7958)	

Cylinder head seat recess diameter

Unit: mm (in)

In.	For standard insert	45.000 - 45.016 (1.7717 - 1.7723)
	For service insert	45.500 - 45.516 (1.7913 - 1.7920)
Ex.	For standard insert	40.000 - 40.016 (1.5748 - 1.5754)
	For service insert	40.500 - 40.516 (1.5945 - 1.5951)

Interference fit of seat insert

Unit: mm (in)

In.	For standard and service parts	0.081 - 0.113 (0.0032 - 0.0044)
	For standard parts	0.064 - 0.096 (0.0025 - 0.0038)
Ex.	For service parts	0.081 - 0.113 (0.0032 - 0.0044)

"Exhaust"

Unit: mm (in)

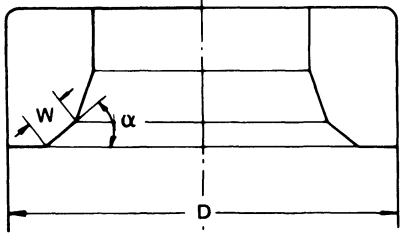
Profile		SEM178
Contacting face angle "α"	45°	
Contacting width "W" Standard	1.5 - 1.9 (0.059 - 0.075)	
Outer diameter "D" Standard	40.080 - 40.096 (1.5779 - 1.5786)	
Service	40.597 - 40.613 (1.5983 - 1.5989)	

Machining dimensions of service seat

Unit: mm (in)

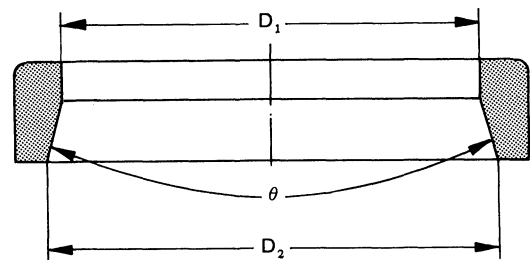

SEM191B

	D ₁	D ₂	θ
Intake	39.0±0.15 (1.535±0.006)	42.0±0.1 (1.654±0.004)	90°
Exhaust	32.0±0.15 (1.260±0.006)	35.8±0.1 (1.409±0.004)	

ROCKER ARM AND ROCKER SHAFT

Unit: mm (in)

Standard	
Rocker arm to shaft clearance	0.007 - 0.049 (0.0003 - 0.0019)
Rocker shaft diameter	19.979 - 20.000 (0.7866 - 0.7874)
Rocker arm rocker shaft hole diameter	20.007 - 20.028 (0.7877 - 0.7885)

Inspection and Adjustment (Cont'd)

CAMSHAFT AND CAMSHAFT BEARING
Camshaft

Unit: mm (in)

	Standard	Limit
Outer diameter of camshaft journal	32.920 - 32.940 (1.2961 - 1.2968)	—
Camshaft runout at center journal (Total indicator reading)	—	0.02 (0.0008)
Camshaft end play	—	0.2 (0.008)

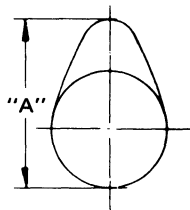

EM671

Cam height "A"	Z24i	INT	38.477 - 38.527 (1.5148 - 1.5168)
		EXT	38.481 - 38.531 (1.5150 - 1.5170)

Valve timing

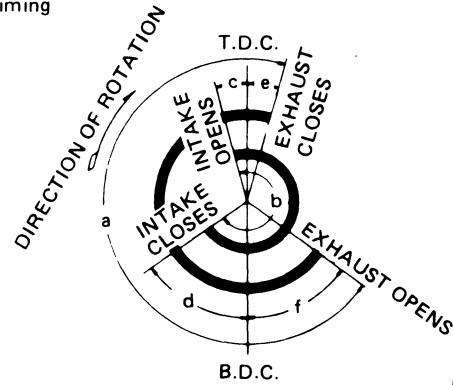

EM120

Unit: degree

a	b	c	d	e	f
248	240	10	50	12	56

Camshaft bearing

Unit: mm (in)

	Standard	Limit
Inner diameter	33.000 - 33.025 (1.2992 - 1.3002)	—
Camshaft journal to bearing clearance [Oil clearance]	0.060 - 0.105 (0.0024 - 0.0041)	0.12 (0.0047)

Inspection and Adjustment (Cont'd)

CYLINDER BLOCK
Cylinder block

Unit: mm (in)

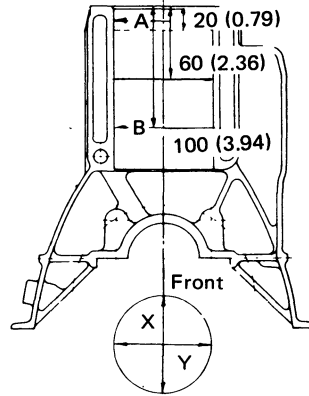

EM422

		Standard	Limit
Distortion		—	0.1 (0.004)
Cylinder bore	Inner diameter	Grade 1	89.000 - 89.010 (3.5039 - 3.5043)
		Grade 2	89.010 - 89.020 (3.5043 - 3.5047)
		Grade 3	89.020 - 89.030 (3.5047 - 3.5051)
		Grade 4	89.030 - 89.040 (3.5051 - 3.5055)
		Grade 5	89.040 - 89.050 (3.5055 - 3.5059)
Out-of-round (X-Y)		Less than 0.015 (0.0006)	—
Taper (A-B)		Less than 0.010 (0.0004)	—
Difference in inner diameter between cylinders		Less than 0.05 (0.0020)	0.2 (0.008)
Piston to cylinder clearance		0.025 - 0.045 (0.0010 - 0.0018)	—
Feeler gauge extracting force [With gauge thickness 0.04 mm (0.0016 in)] N (kg, lb)		2.0 - 14.7 (0.2 - 1.5, 0.4 - 3.3)	—
Cylinder block height (From crankshaft center)		247.00±0.05 (9.7244±0.0020)	

* Wear limit

Inspection and Adjustment (Cont'd)

PISTON, PISTON RING AND PISTON PIN
Piston

Unit: mm (in)

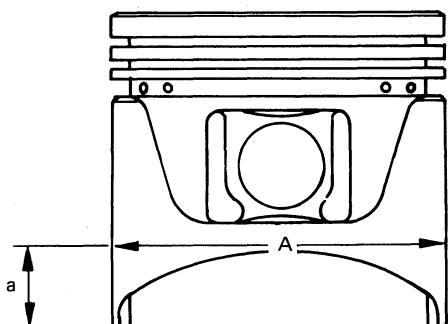

a: 20 (0.79)

SEM178B

Piston skirt diameter "A"

Standard		88.965 - 89.015 (3.5026 - 3.5045)
For service	Standard	88.985 - 89.035 (3.5033 - 3.5053)
	0.50 (0.0197) oversize	89.465 - 89.515 (3.5222 - 3.5242)
	1.00 (0.0394) oversize	89.965 - 90.015 (3.5419 - 3.5439)

Side clearance of piston ring

Unit: mm (in)

	Standard	Limit
Top ring	0.040 - 0.073 (0.0016 - 0.0029)	0.1 (0.004)
Second ring	0.030 - 0.063 (0.0012 - 0.0025)	
Oil ring	-	-

Ring gap

Unit: mm (in)

	Standard	Limit
Top ring	0.28 - 0.38 (0.0110 - 0.0150)	0.5 (0.020)
Second ring	0.25 - 0.35 (0.0098 - 0.0138)	
Oil ring	0.20 - 0.60 (0.0079 - 0.0236)	

Piston pin

Unit: mm (in)

	Standard
Piston pin outside diameter	20.993 - 20.998 (0.8265 - 0.8267)
Piston pin hole diameter	21.001 - 21.008 (0.8268 - 0.8271)
Piston pin to piston clearance	0.008 - 0.012 (0.0003 - 0.0005)
Interference fit of piston pin to connecting rod	0.015 - 0.033 (0.0006 - 0.0013)

CONNECTING ROD

Unit: mm (in)

	Standard	Limit
Connecting rod bend or torsion [per 100 mm (3.94 in) length]	0.025 (0.0010)	0.05 (0.0020)
Side clearance	0.2 - 0.3 (0.008 - 0.012)	0.6 (0.024)
Center distance	164.97 - 165.03 (6.4949 - 6.4972)	
Piston pin bore diameter	20.965 - 20.978 (0.8254 - 0.8259)	

Inspection and Adjustment (Cont'd)

CRANKSHAFT

Unit: mm (in)

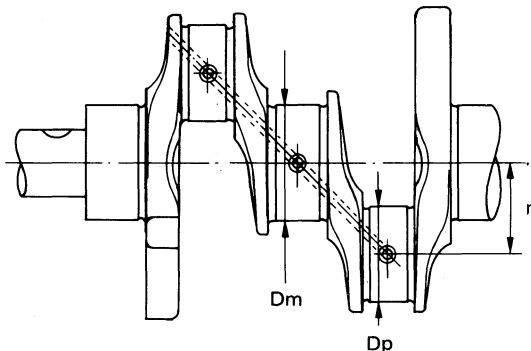

SEM394

Journal diameter "Dm"	59.942 - 59.955 (2.3599 - 2.3604)
Pin diameter "Dp"	49.961 - 49.974 (1.9670 - 1.9675)
Center distance "r"	47.97 - 48.03 (1.8886 - 1.8909)

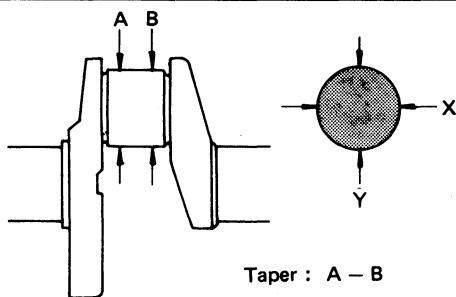

Taper : A - B
Out-of-round : X - Y SEM316A

	Standard	Limit
Taper of journal and pin "A-B"	Less than 0.005 (0.0002)	0.01 (0.0004)
Out-of-round of journal and pin "X-Y"	Less than 0.005 (0.0002)	0.01 (0.0004)
Crankshaft runout	Less than 0.025 (0.0010)	0.05 (0.0020)
Crankshaft free end play	0.05 - 0.18 (0.0020 - 0.0071)	0.3 (0.012)
Pilot bushing inserting distance	4.0 (0.157)	
Fillet roll	More than 0.1 (0.004)	

BEARING

Bearing clearance

Unit: mm (in)

	Standard	Limit
Main bearing clearance	No. 1 & No. 5 bearings 0.020 - 0.062 (0.0008 - 0.0024)	0.12 (0.0047)
	No. 2, No. 3 & No. 4 bearings 0.020 - 0.075 (0.0008 - 0.0030)	
Connecting rod bearing clearance	0.014 - 0.048 (0.0006 - 0.0019)	0.08 (0.0031)

Main bearing undersize

Unit: mm (in)

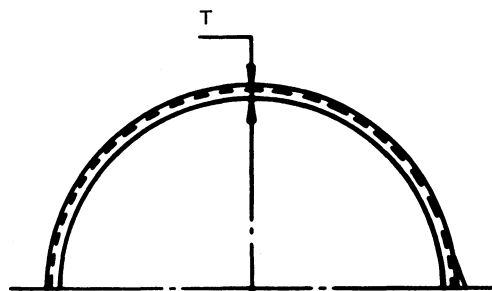

EM738

	Bearing top thickness "T"	Crank journal diameter
Standard	1.827 - 1.835 (0.0719 - 0.0722)	59.942 - 59.955 (2.3599 - 2.3604)
0.25 (0.0098) Undersize	1.947 - 1.960 (0.0767 - 0.0772)	59.692 - 59.705 (2.3501 - 2.3506)

Inspection and Adjustment (Cont'd)

Connecting rod bearing undersize

Unit: mm (in)

	Bearing top thickness "T"	Crank pin diameter
Standard	1.502 - 1.506 (0.0591 - 0.0593)	49.961 - 49.974 (1.9670 - 1.9675)
0.06 (0.0024) Undersize	1.553 - 1.561 (0.0611 - 0.0615)	49.901 - 49.914 (1.9646 - 1.9651)
0.12 (0.0047) Undersize	1.613 - 1.621 (0.0635 - 0.0638)	49.841 - 49.854 (1.9622 - 1.9628)
0.25 (0.0098) Undersize	1.618 - 1.631 (0.0637 - 0.0642)	49.711 - 49.724 (1.9571 - 1.9576)
0.50 (0.0197) Undersize	1.743 - 1.756 (0.0686 - 0.0691)	49.461 - 49.474 (1.9473 - 1.9478)
0.75 (0.0295) Undersize	1.868 - 1.881 (0.0735 - 0.0741)	49.211 - 49.224 (1.9374 - 1.9379)

MISCELLANEOUS COMPONENTS

Camshaft sprocket

Unit: mm (in)

Runout (Total indicator reading)	Limit 0.1 (0.004)
----------------------------------	-------------------

Flywheel

Unit: mm (in)

Runout (Total indicator reading)	Limit 0.10 (0.0039)
----------------------------------	---------------------

Tightening Torque

Unit	N-m	kg-m	ft-lb
Engine front side			
Front cover bolt			
M8	10 - 16	1.0 - 1.6	7 - 12
M6	4 - 10	0.4 - 1.0	2.9 - 7.2
Chain guide bolt	6 - 10	0.6 - 1.0	4.3 - 7.2
Chain tensioner bolt	6 - 10	0.6 - 1.0	4.3 - 7.2
Water pump bolt			
M6	4 - 10	0.4 - 1.0	2.9 - 7.2
M8	10 - 16	1.0 - 1.6	7 - 12
Crank pulley bolt	118 - 157	12 - 16	87 - 116
Engine right side			
Water inlet bolt	10 - 13	1.0 - 1.3	7 - 9
Thermostat housing bolt	10 - 13	1.0 - 1.3	7 - 9
Intake manifold bolt and nut	16 - 21	1.6 - 2.1	12 - 15
Alternator bracket bolt	39 - 59	4.0 - 6.0	29 - 43
Alternator to adjusting bar bolt	8 - 11	0.8 - 1.1	5.8 - 8.0
Alternator to bracket bolt	36 - 50	3.7 - 5.1	27 - 37
Fuel pump nut	12 - 18	1.2 - 1.8	9 - 13
Injection body nut	12 - 18	1.2 - 1.8	9 - 13
Engine left side			
Distributor support bolt	4 - 8	0.4 - 0.8	2.9 - 5.8
Exhaust manifold bolt and nut	16 - 21	1.6 - 2.1	12 - 15
Air conditioner compressor bracket bolt	69 - 78	7.0 - 8.0	51 - 58
Air conditioner compressor to bracket bolt	36 - 50	3.7 - 5.1	27 - 37
Exhaust manifold to exhaust front tube	26 - 36	2.7 - 3.7	20 - 27

Unit	N-m	kg-m	ft-lb	
Engine top side				
Cylinder head bolt	74 - 83	7.5 - 8.5	54 - 61	
Cylinder head to front cover bolt	4 - 10	0.4 - 1.0	2.9 - 7.2	
Rocker shaft bracket bolt	15 - 25	1.5 - 2.5	11 - 18	
Camshaft sprocket bolt	118 - 157	12 - 16	87 - 116	
Rocker cover bolt	1 - 3	0.1 - 0.3	0.7 - 2.2	
Spark plug	20 - 29	2.0 - 3.0	14 - 22	
Valve clearance adjust screw lock nut	16 - 22	1.6 - 2.2	12 - 16	
Engine bottom side				
Main bearing cap bolt	44 - 54	4.5 - 5.5	33 - 40	
Connecting rod big end nut	Refer to page EM-98.			
Oil strainer bolt	16 - 21	1.6 - 2.1	12 - 15	
Oil pan bolt	7 - 8	0.7 - 0.8	5.1 - 5.8	
Oil pan drain plug	29 - 39	3.0 - 4.0	22 - 29	
Oil pump bolt	11 - 15	1.1 - 1.5	8 - 11	
Gusset to cylinder block bolt	43 - 58	4.4 - 5.9	32 - 43	
Engine rear side				
Flywheel bolt	137 - 157	14 - 16	101 - 116	
Clutch cover bolt	16 - 21	1.6 - 2.1	12 - 15	
Starter motor bolt	29 - 39	3.0 - 4.0	22 - 29	
Transmission to cylinder block bolt	Short bolt	29 - 39	3.0 - 4.0	22 - 29
	Long bolt	39 - 49	4.0 - 5.0	29 - 36
Transmission to gusset bolt	43 - 58	4.4 - 5.9	32 - 43	

ENGINE LUBRICATION & COOLING SYSTEMS

SECTION **LC**

LC

CONTENTS

PREPARATION LC- 2

VG30i

ENGINE LUBRICATION SYSTEM LC- 3
ENGINE COOLING SYSTEM LC- 7
SERVICE DATA AND SPECIFICATIONS (S.D.S.) LC-12

Z24i

ENGINE LUBRICATION SYSTEM LC-13
ENGINE COOLING SYSTEM LC-17
SERVICE DATA AND SPECIFICATIONS (S.D.S.) LC-22

PREPARATION

SPECIAL SERVICE TOOLS

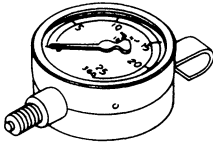
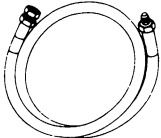
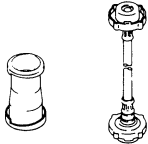
Tool number (Kent-Moore No.) Tool name	Description	Engine application	
		VG30i	Z24i
ST25051001 (J25695-1) Oil pressure gauge		X	X
ST25052000 (J25695-2) Hose		X	X
EG17650301 (-) Radiator cap tester adapter		X	X

Lubrication Circuit

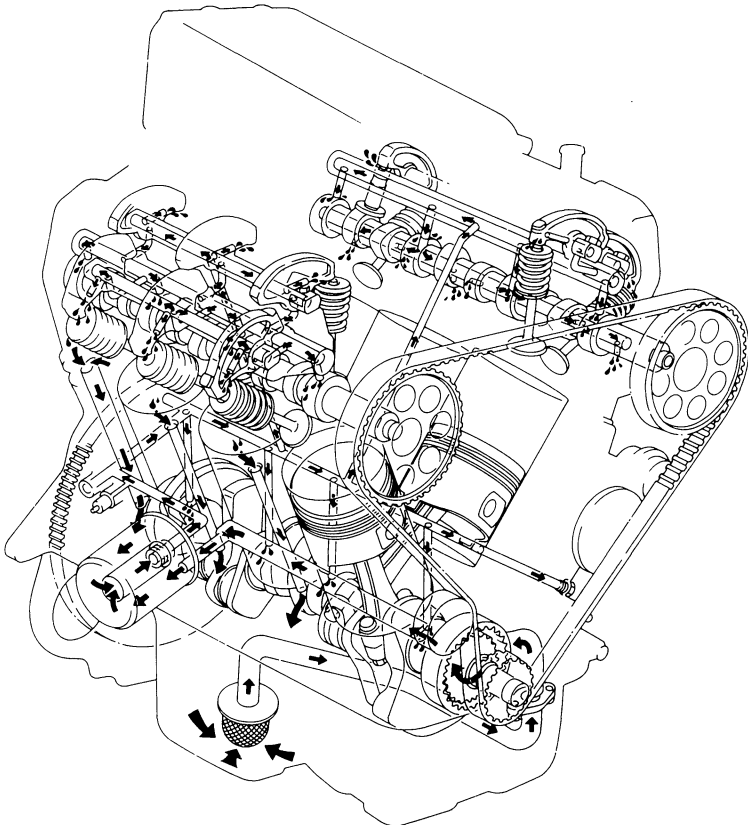

Note:

- ← : Oil passage
- ← : Oil gallery in cylinder block
- ← : By-pass passage

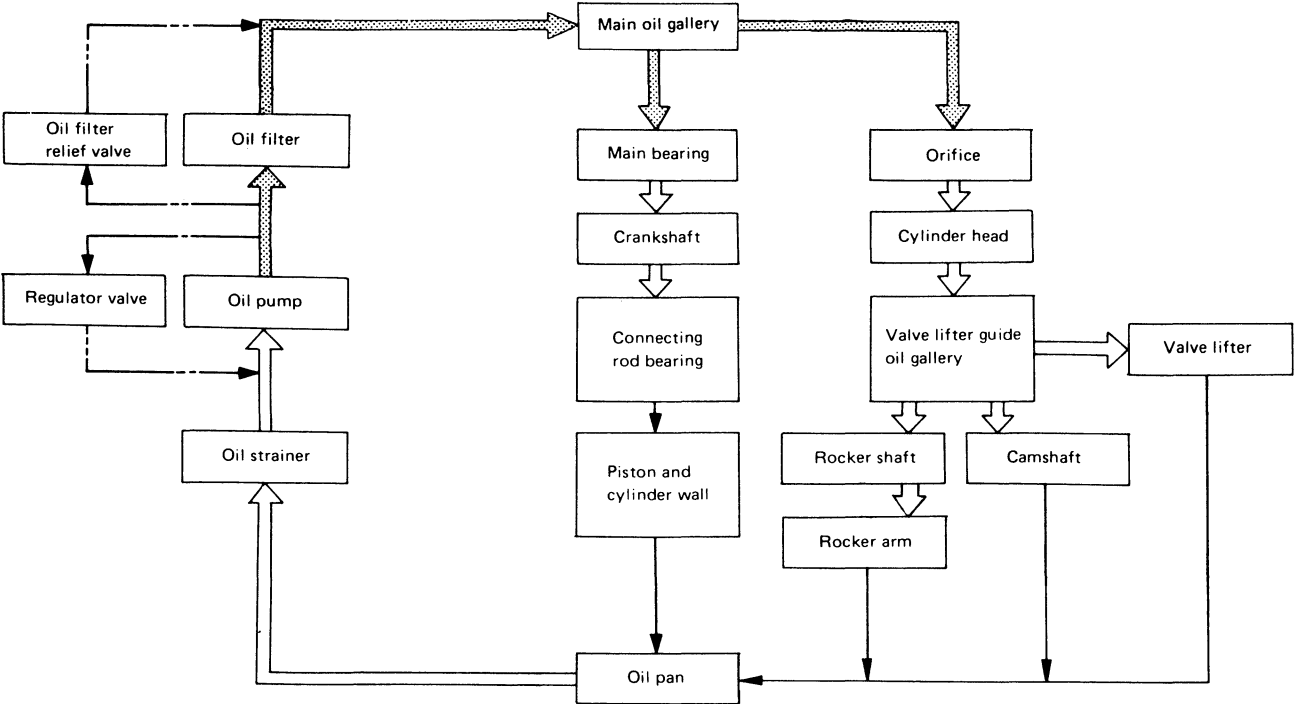

Oil Pressure Check

WARNING:

- Be careful not to burn yourself, as the engine and oil may be hot.
- Oil pressure check should be done in "Neutral" gear position.

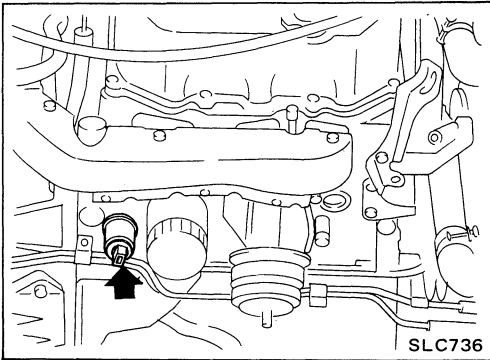

1. Check oil level.
2. Remove oil pressure switch.

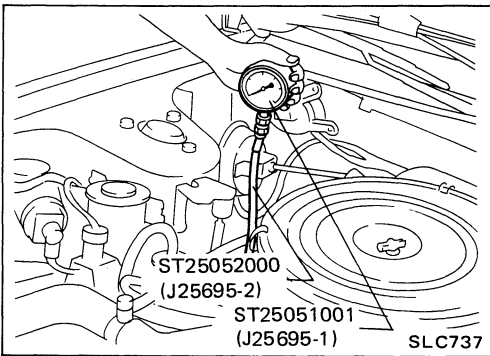

3. Install pressure gauge.
4. Start engine and warm it up to normal operating temperature, and then check oil pressure with engine running under no-load.

Engine rpm	Approximate discharge pressure kPa (kg/cm ² , psi)
Idle speed 3,200	More than 59 (0.6, 9) 363 - 461 (3.7 - 4.7, 53 - 67)

If difference is extreme, check oil passage and oil pump for oil leaks.

5. Install oil pressure switch.

Use proper liquid sealant.

Oil pressure switch:

 : 10 - 16 N·m
(1.0 - 1.6 kg-m, 7 - 12 ft-lb)

Oil Pump

REMOVAL

1. Drain oil.
2. Remove oil pan.

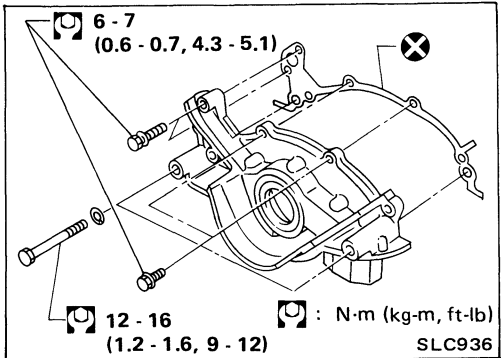

3. Remove oil pump assembly.

DISASSEMBLY AND ASSEMBLY

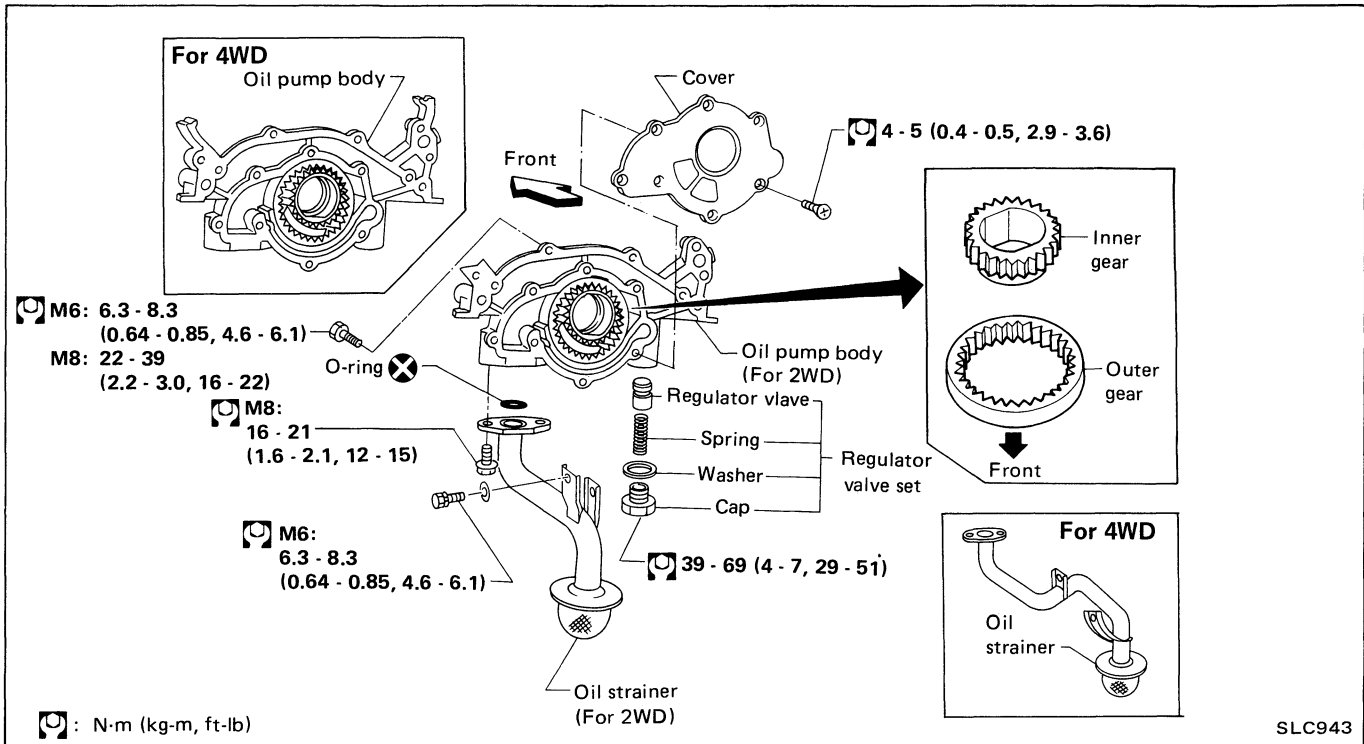

- When installing oil pump, apply engine oil to inner and outer gear.
- Be sure that O-ring is properly fitted on.

Oil Pump (Cont'd)

REGULATOR VALVE INSPECTION

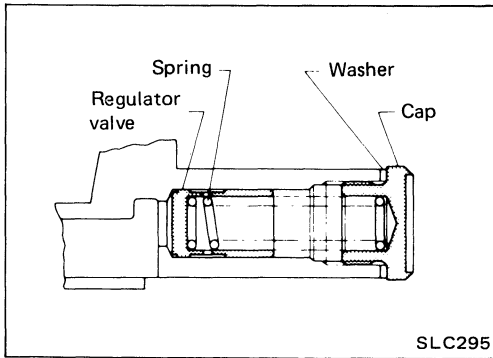

1. Visually inspect components for wear and damage.
2. Check oil pressure regulator valve sliding surface and valve spring.
3. Coat regulator valve with engine oil and check that it falls smoothly into the valve hole by its own weight.

If damaged, replace regulator valve set or oil pump assembly.

OIL PRESSURE RELIEF VALVE INSPECTION

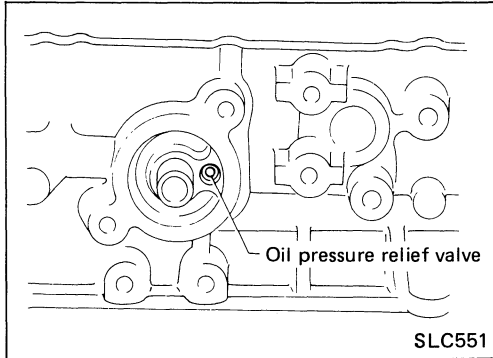

Inspect oil pressure relief valve for movement, cracks and breaks by pushing the ball. If replacement is necessary, remove valve by prying it out with a screwdriver.

Install a new valve in place by tapping it.

OIL PUMP INSPECTION

Using a feeler gauge, check the following clearance.

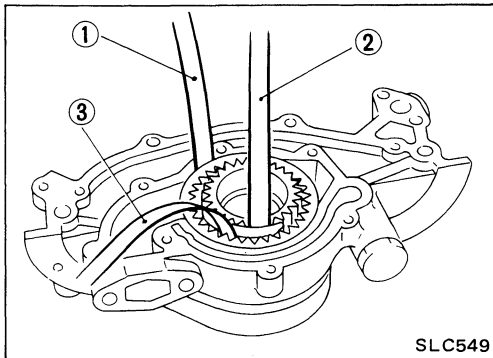

Unit: mm (in)

Body to outer gear clearance ①	0.11 - 0.20 (0.0043 - 0.0079)
Inner gear to crescent clearance ②	0.12 - 0.23 (0.0047 - 0.0091)
Outer gear to crescent clearance ③	0.21 - 0.32 (0.0083 - 0.0126)
Housing to inner gear clearance ④	0.05 - 0.09 (0.0020 - 0.0035)
Housing to outer gear clearance ⑤	0.05 - 0.11 (0.0020 - 0.0043)

If it exceeds the limit, replace gear set or entire oil pump assembly.

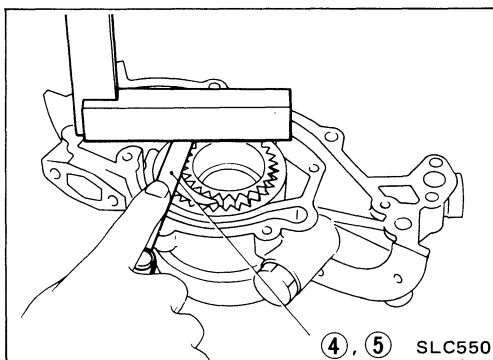

Cooling Circuit

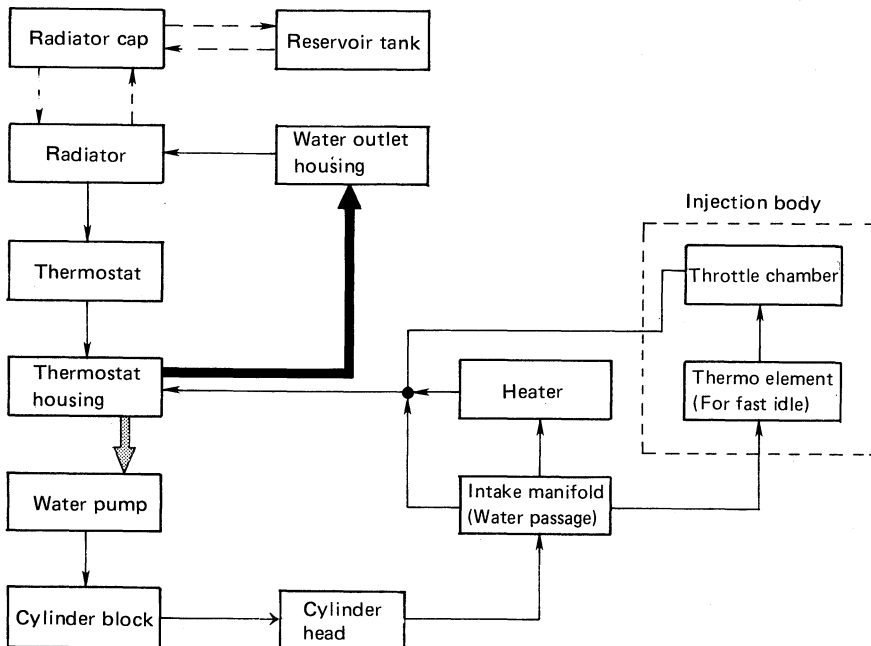
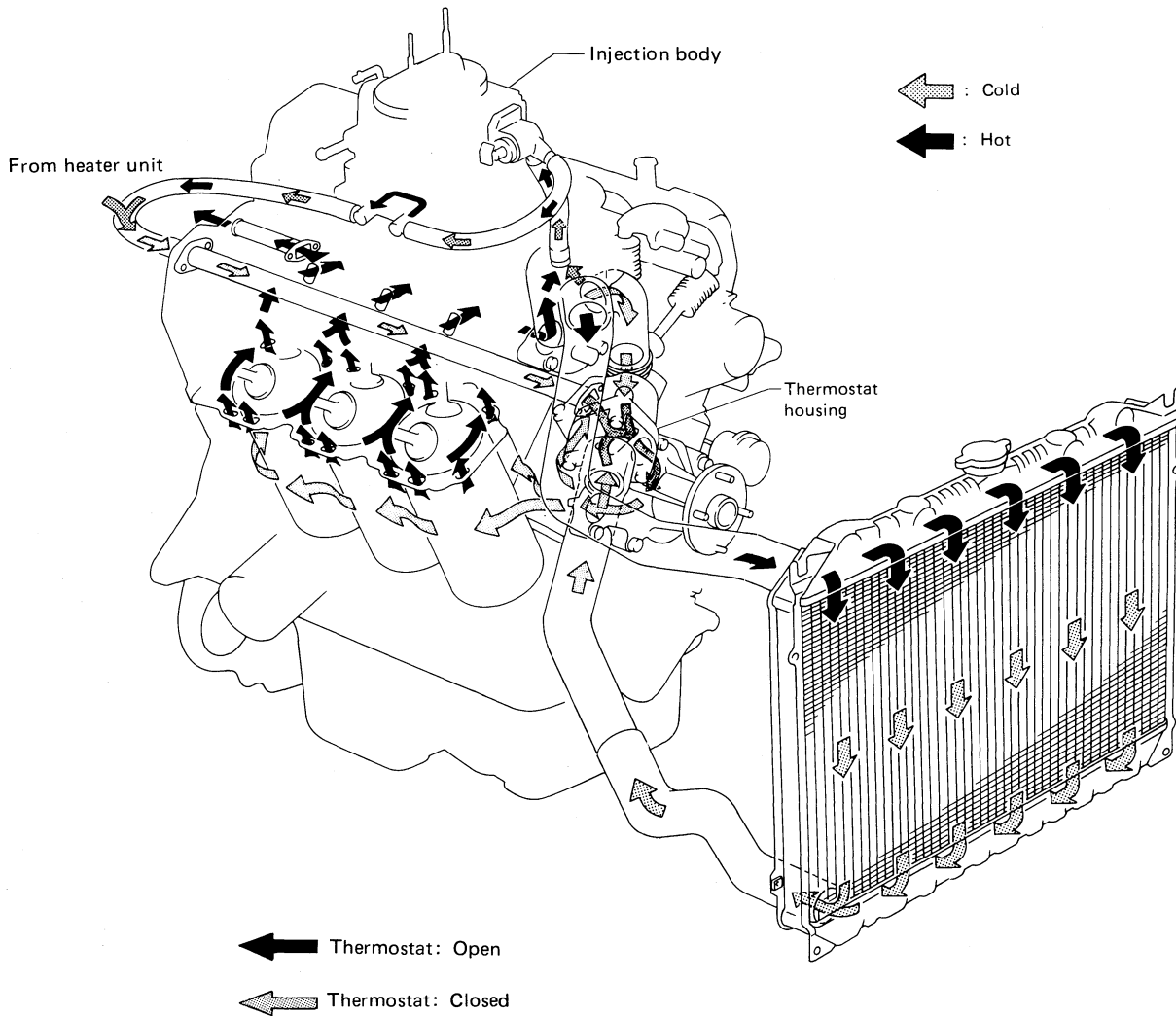

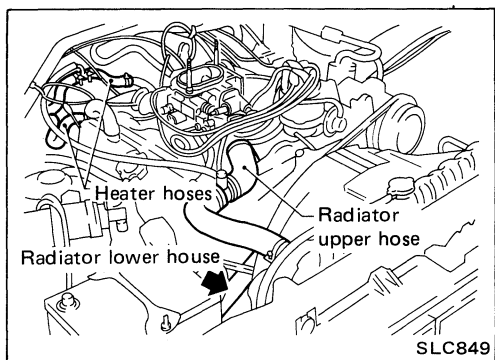

Cooling System Inspection

CHECKING HOSES

Check hoses for proper attachment, leaks, cracks, damage, loose connections, chafing and deterioration.

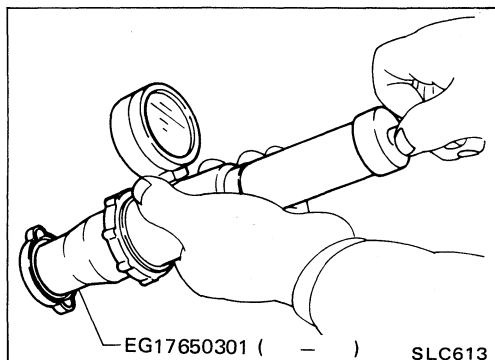

CHECKING RADIATOR CAP

Apply pressure to radiator cap by means of a cap tester to see if it is satisfactory.

Radiator cap relief pressure:

78 - 98 kPa

(0.8 - 1.0 kg/cm² , 11 - 14 psi)

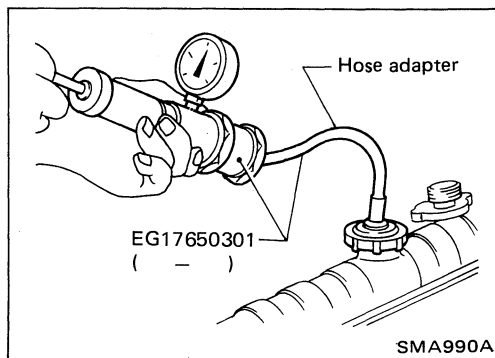

CHECKING COOLING SYSTEM FOR LEAKS

Apply pressure to the cooling system by means of a tester to check for leakage.

Testing pressure:

157 kPa (1.6 kg/cm² , 23 psi)

CAUTION:

Higher than the specified pressure may cause radiator damage.

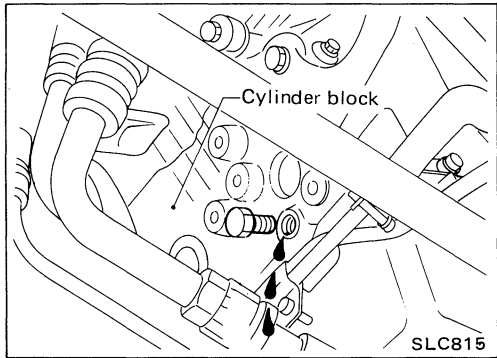

Water Pump REMOVAL AND INSTALLATION

Drain coolant from drain plug behind the alternator from cylinder block and radiator.

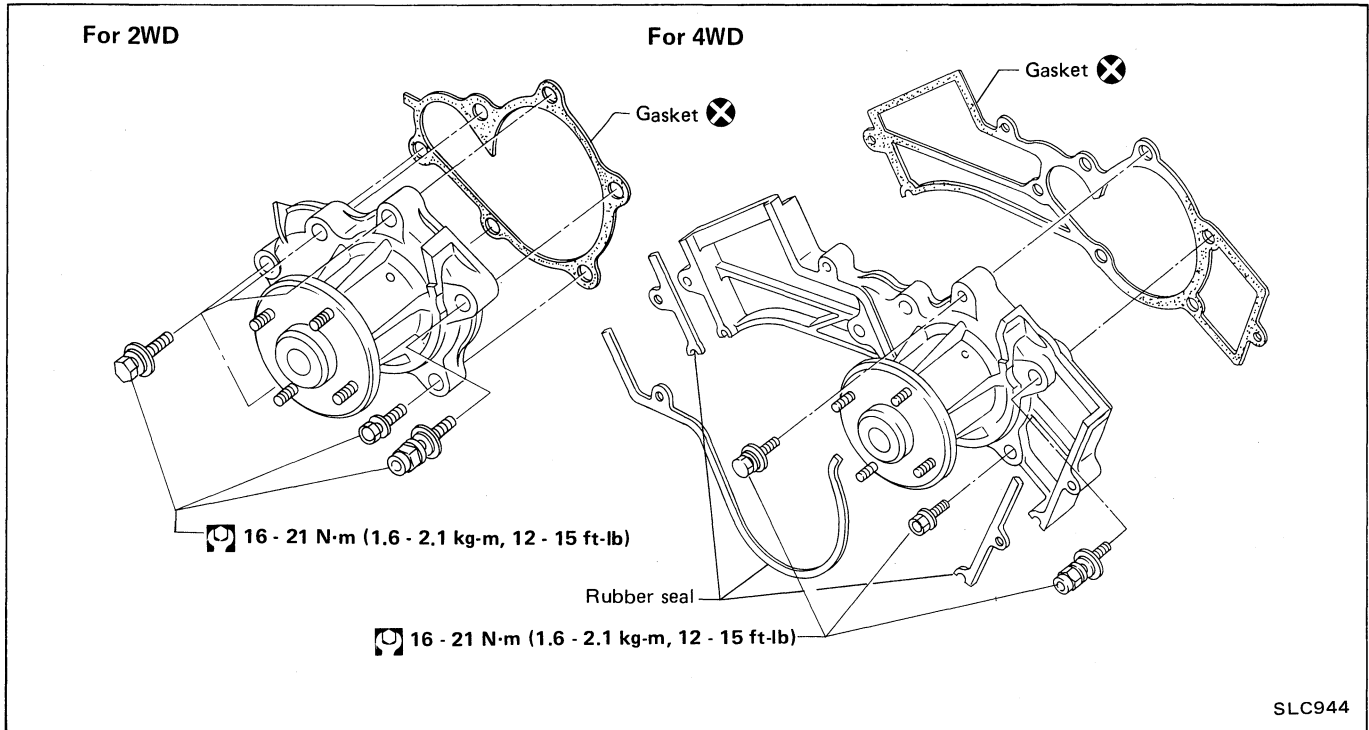

CAUTION:

- When removing water pump assembly, be careful not to get coolant on timing belt.
- Water pump cannot be disassembled and should be replaced as a unit.
- To avoid deforming timing cover, make sure there is adequate clearance between cover and hose clamp.
- After installing water pump, connect hose and clamp securely, then check for leaks using radiator cap tester.

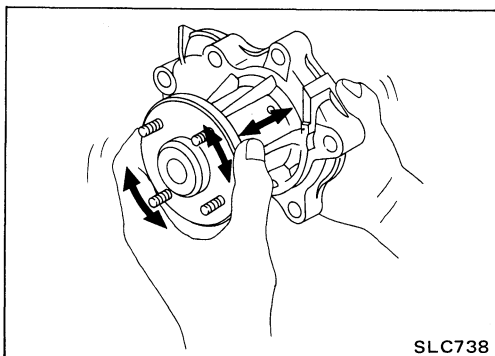

INSPECTION

1. Check for badly rusted or corroded body assembly and vane.
2. Check for rough operation due to excessive end play.

Thermostat

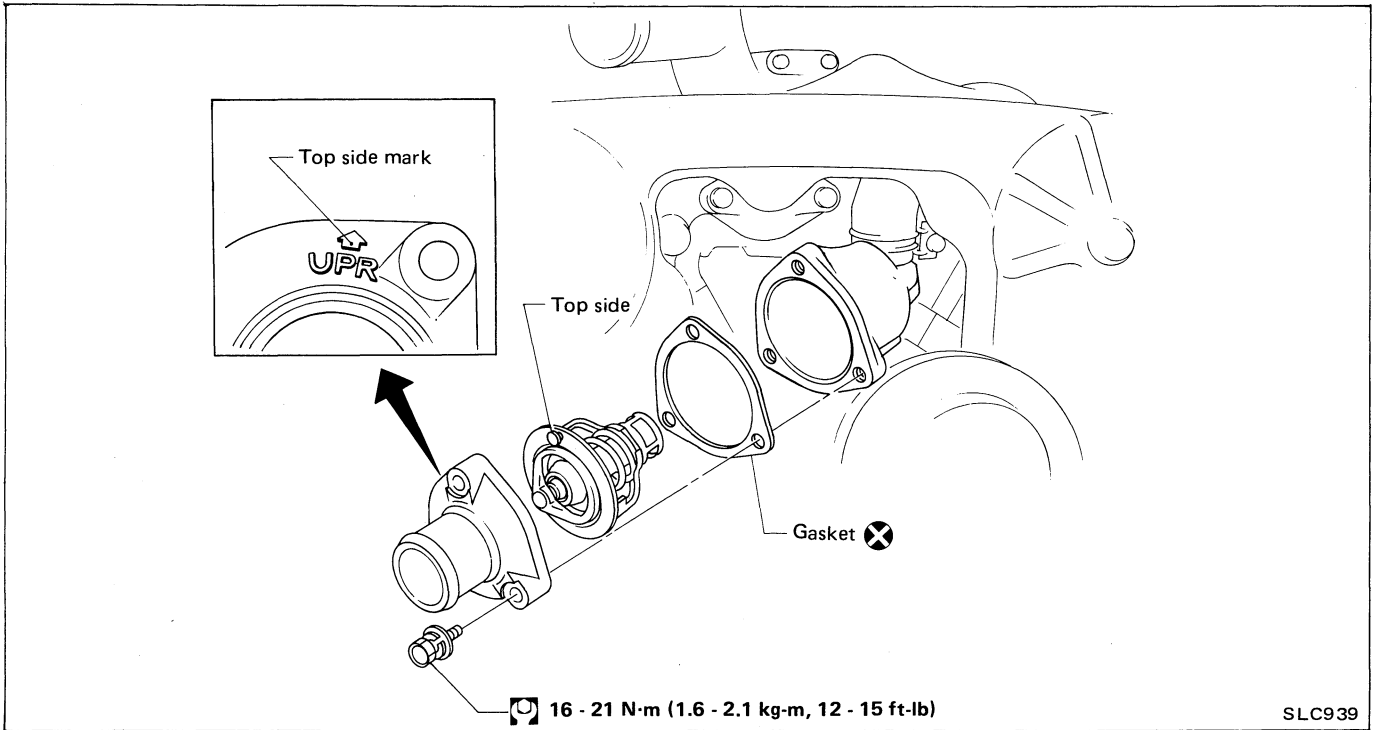

- After installation, run engine for a few minutes, and check for leaks.
- Be careful not to spill coolant over engine compartment. Place a rag to absorb coolant.

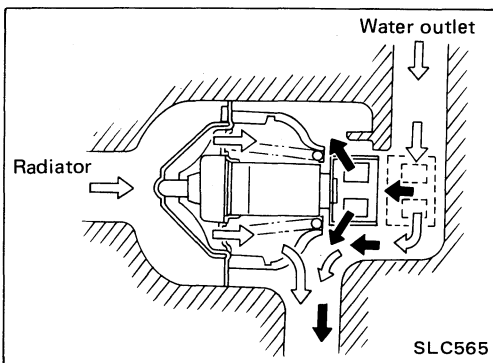

DESCRIPTION

Thermostat	Coolant flows out through water outlet	
Open	⇨	A little
Closed	➔	Much

INSPECTION

1. Check valve seating condition at ordinary temperatures. It should seat tightly.
2. Check valve opening temperature and maximum valve lift.

		Standard
Valve opening temperature	°C (°F)	68.5 (155)
Maximum valve lift	mm/°C (in/°F)	10/90 (0.39/194)

3. Then check if valve closes at 5°C (9°F) below valve opening temperature.

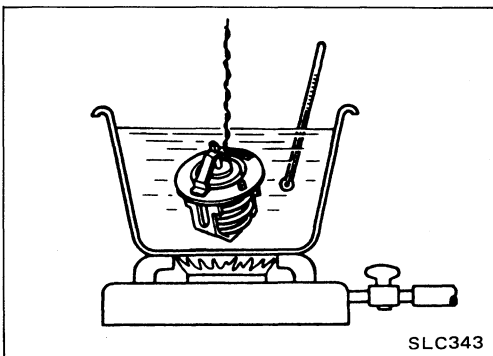

Radiator

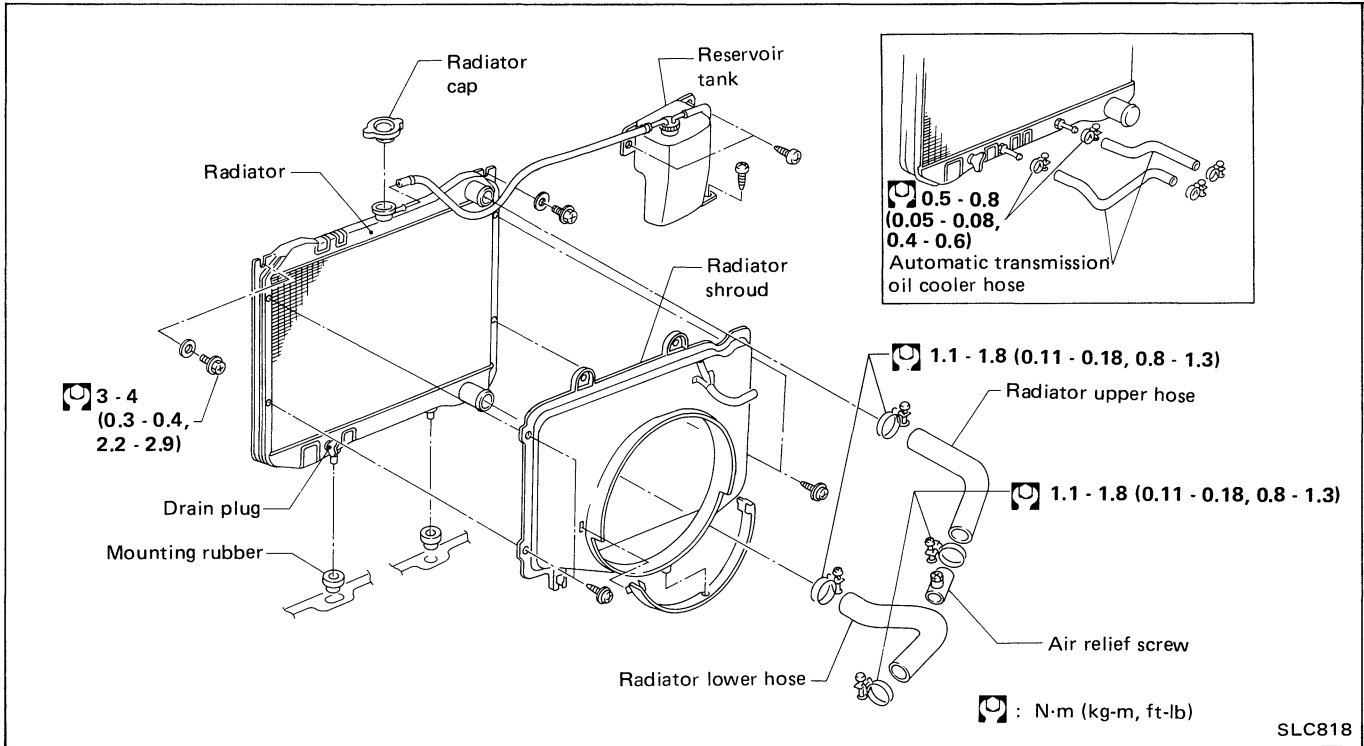

CAUTION:
When filling radiator with coolant, refer to MA section.

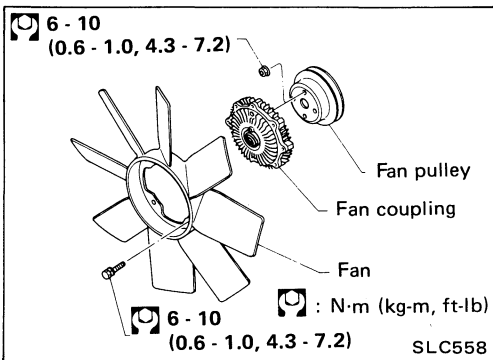

Cooling Fan

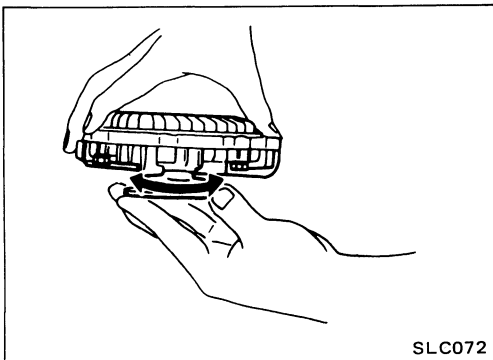

INSPECTION
Check fan coupling for oil leakage or bent bimetal.

Engine Lubrication System

Oil pressure check

Engine rpm	Approximate discharge pressure kPa (kg/cm ² , psi)
Idle speed 3,200	More than 59 (0.6, 9) 363 - 461 (3.7 - 4.7, 53 - 67)

Oil pump

Unit: mm (in)

Body to outer gear clearance ①	0.11 - 0.20 (0.0043 - 0.0079)
Inner gear to crescent clearance ②	0.12 - 0.23 (0.0047 - 0.0091)
Outer gear to crescent clearance ③	0.21 - 0.32 (0.0083 - 0.0126)
Housing to inner gear clearance ④	0.05 - 0.09 (0.0020 - 0.0035)
Housing to outer gear clearance ⑤	0.05 - 0.11 (0.0020 - 0.0043)

Tightening torque

Unit	N·m	kg·m	ft·lb
Oil pump securing bolt			
M6	6.3 - 8.3	0.64 - 0.85	4.6 - 6.1
M8	22 - 29	2.2 - 3.0	16 - 22
Oil pump cover screw	4 - 5	0.4 - 0.5	2.9 - 3.6
Regulator valve cap bolt	39 - 69	4 - 7	29 - 51
Oil strainer bolt			
M6	6.3 - 8.3	0.64 - 0.85	4.6 - 6.1
M8	16 - 21	1.6 - 2.1	12 - 15
Oil pressure switch	10 - 16	1.0 - 1.6	7 - 12

Engine Cooling System

Thermostat

	Standard
Valve opening temperature °C (°F)	68.5 (155)
Maximum valve lift mm / °C (in / °F)	10/90 (0.39/194)

Radiator

Unit: kPa (kg/cm², psi)

Cap relief pressure	78 - 98 (0.8 - 1.0, 11 - 14)
Leakage test pressure	157 (1.6, 23)

Tightening torque

Unit	N·m	kg·m	ft·lb
Water pump securing bolt	16 - 21	1.6 - 2.1	12 - 15
Thermostat housing securing bolt	16 - 21	1.6 - 2.1	12 - 15
Radiator securing bolt	3 - 4	0.3 - 0.4	2.2 - 2.9
Radiator			
Upper & lower hose	1.1 - 1.8	0.11 - 0.18	0.8 - 1.3
Oil cooler hose (For A/T)	0.5 - 0.8	0.05 - 0.08	0.4 - 0.6
Fan coupling securing bolt	6 - 10	0.6 - 1.0	4.3 - 7.2
Fan securing bolt	6 - 10	0.6 - 1.0	4.3 - 7.2
Cylinder block drain plug	34 - 44	3.5 - 4.5	25 - 33

Lubricating Circuit

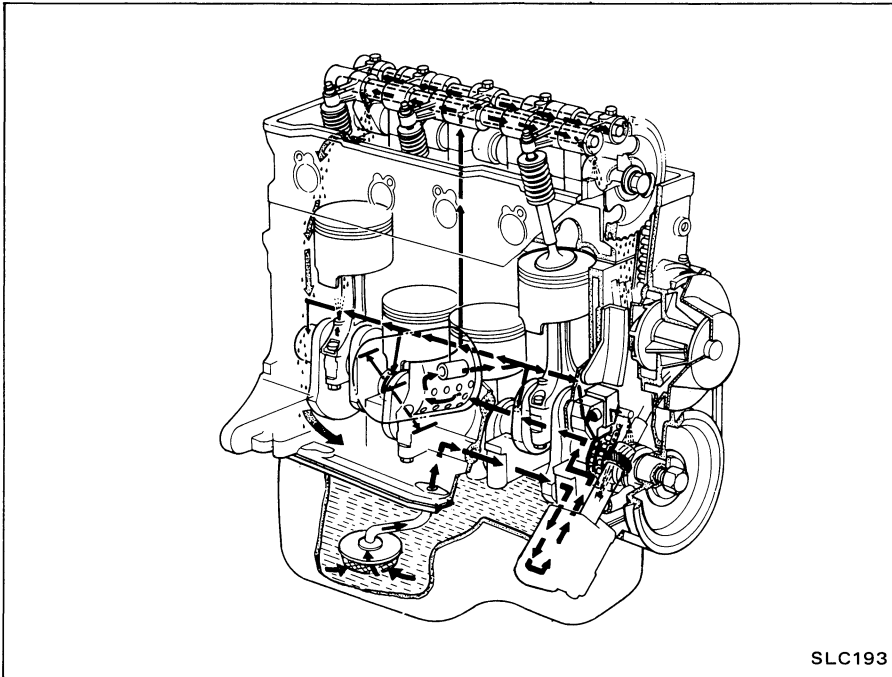

SLC193

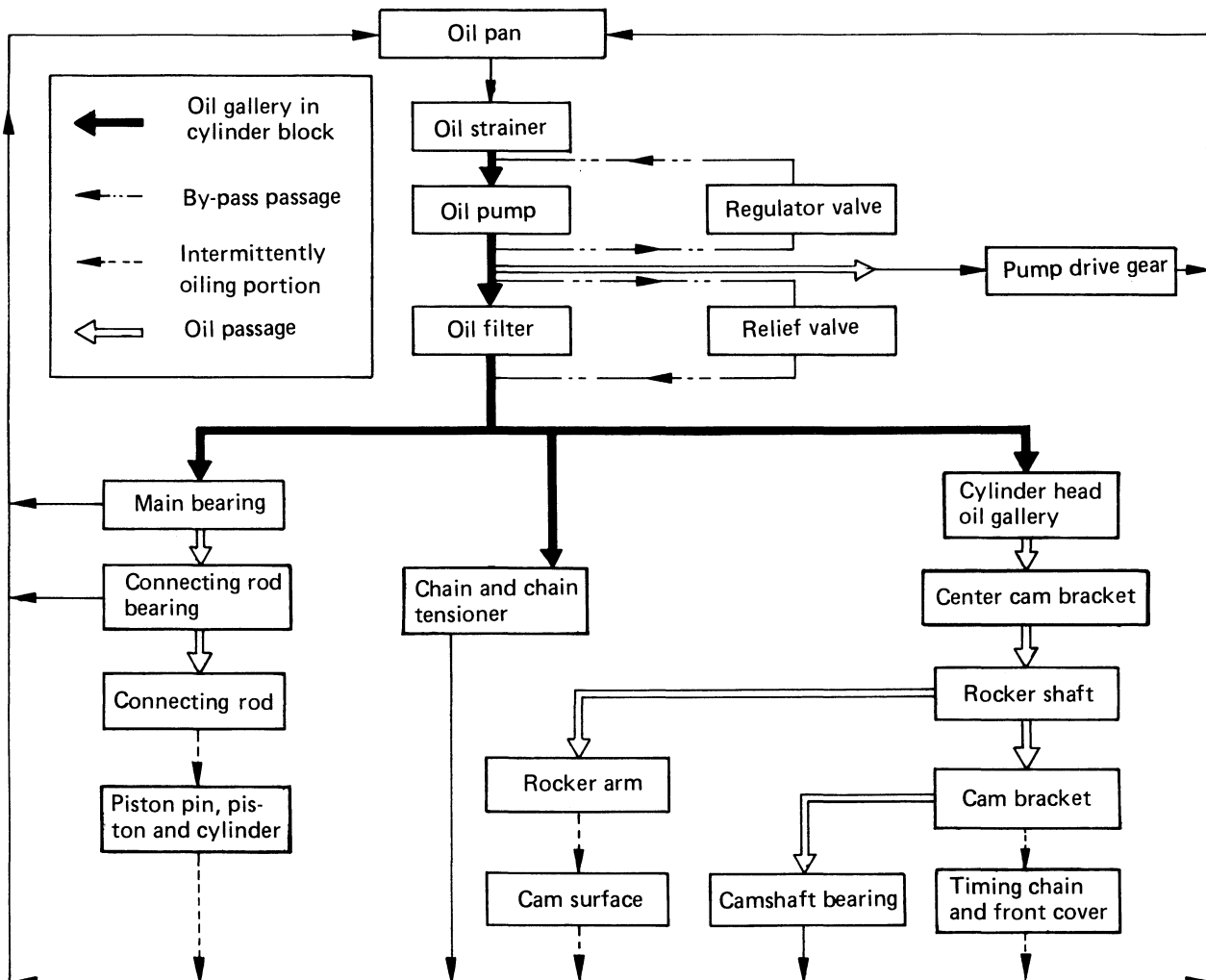

SLC711

Oil Pressure Check

WARNING:

- Be careful not to burn yourself, as the engine and oil may be hot.
- Oil pressure check should be done in "Neutral" gear position.

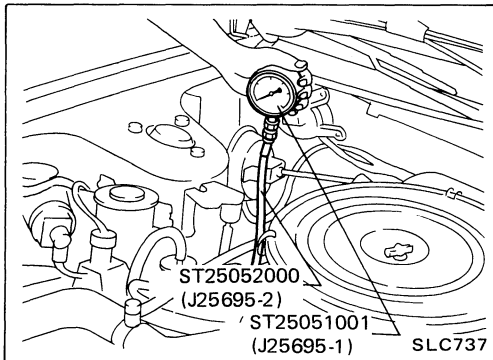
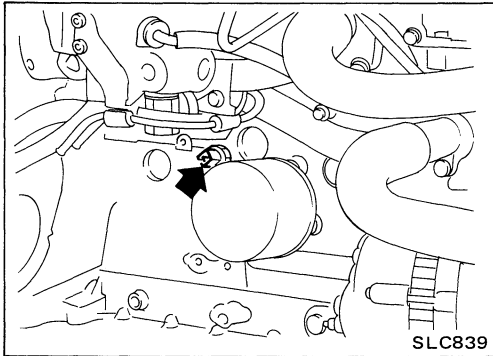

1. Check oil level.
2. Remove oil pressure switch.
3. Install pressure gauge.
4. Start and warm up engine to normal operating temperature.
5. Check oil pressure with engine running under no-load.

Engine rpm	Approximate discharge pressure kPa (kg/cm ² , psi)
Idle speed	More than 73.6 (0.75, 10.7)
3,000	324 - 461 (3.3 - 4.7, 47 - 67)

If difference is extreme, check oil passage and oil pump for oil leaks.

6. Install oil pressure switch.

Use proper liquid sealant.

Oil pressure switch:

 : 10 - 16 N·m (1.0 - 1.6 kg-m, 7 - 12 ft-lb)

Oil Pump

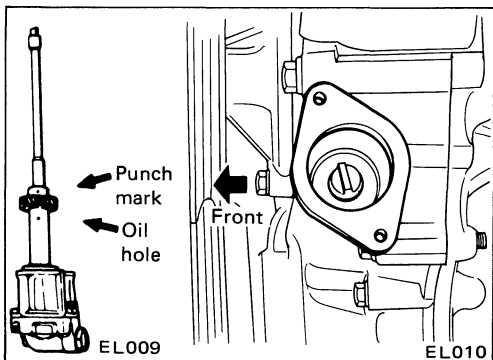
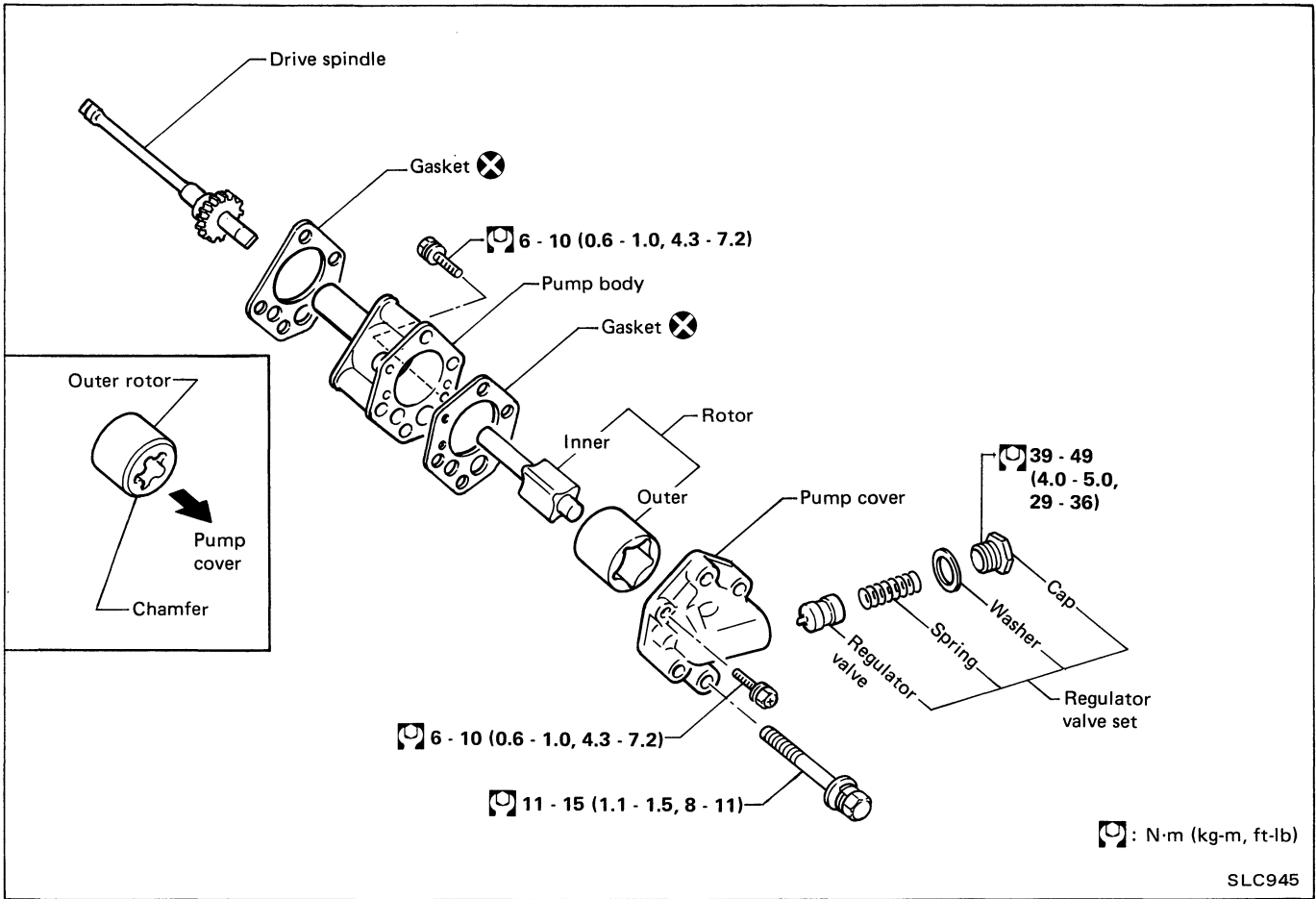

- Always replace with new oil seal and gasket.
- When removing oil pump, turn crankshaft so that No. 1 piston is at T.D.C. on its compression stroke.
- When installing oil pump, align punch mark on drive spindle and oil hole on oil pump.

Oil Pump (Cont'd)

REGULATOR VALVE INSPECTION

1. Visually inspect components for wear and damage.
2. Check oil pressure regulator valve sliding surface and valve spring.
3. Coat regulator valve with engine oil and check that it falls smoothly into the valve hole by its own weight.

If damaged, replace regulator valve set or oil pump assembly.

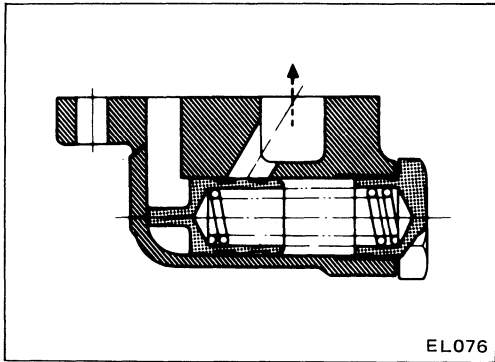

EL076

OIL PRESSURE RELIEF VALVE INSPECTION

Inspect oil pressure relief valve for movement, cracks and breaks by pushing the ball. If replacement is necessary, remove valve by prying it out with a screwdriver.

Install a new valve in place by tapping it.

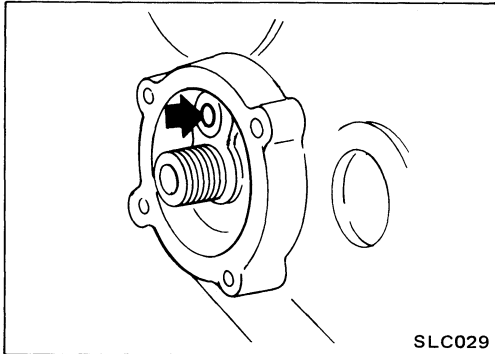

SLC029

OIL PUMP INSPECTION

Using a feeler gauge, check the following clearance.

Unit: mm (in)

Rotor tip clearance ①	Less than 0.12 (0.0047)
Outer rotor to body clearance ②	0.15 - 0.21 (0.0059 - 0.0083)
Side clearance (with gasket) ③	0.04 - 0.08 (0.0016 - 0.0031)

If it exceeds the limit, replace gear set or entire oil pump assembly.

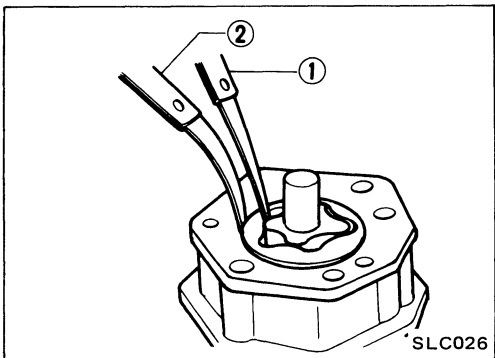

SLC026

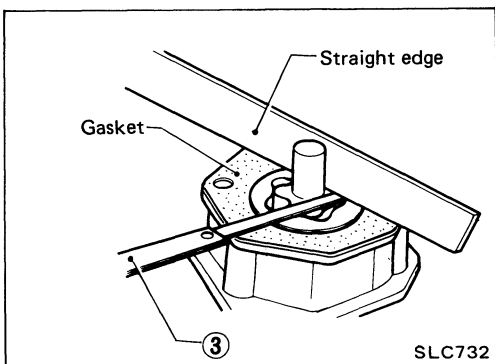

SLC732

Cooling Circuit

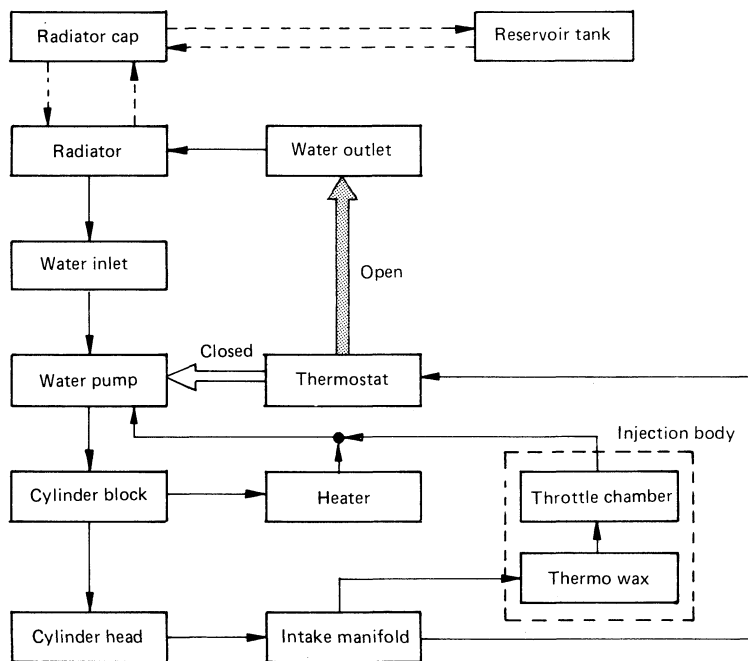
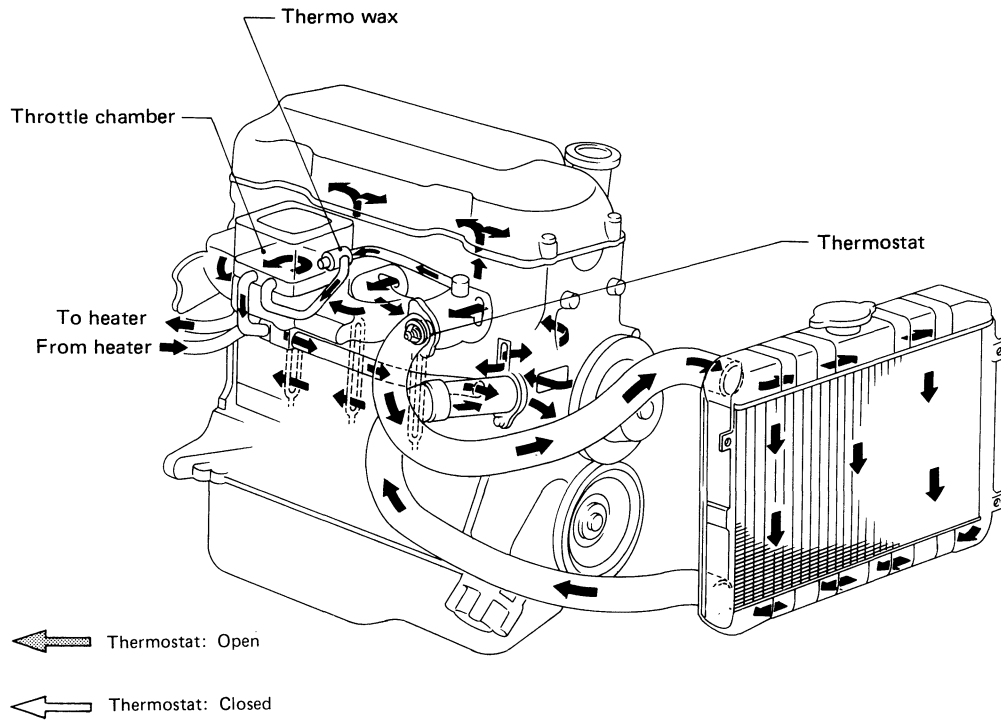

SLC774

WARNING:

To avoid serious personal injury, never remove radiator cap quickly when engine is hot. Sudden release of cooling system pressure is very dangerous.

If it is necessary to remove radiator cap when radiator is hot, turn cap slowly counterclockwise to the first stop. After all pressure in the cooling system is released, turn cap passing the stop and remove it.

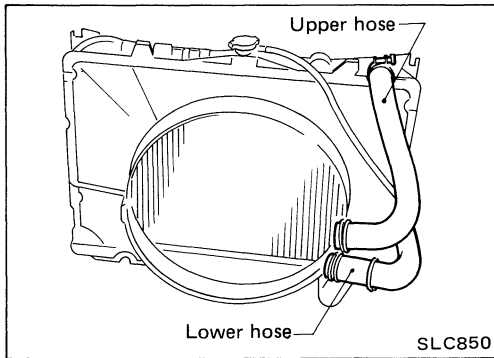

Cooling System Inspection

CHECKING HOSES

Check hoses for proper attachment, leaks, cracks, damage, loose connections, chafing and deterioration.

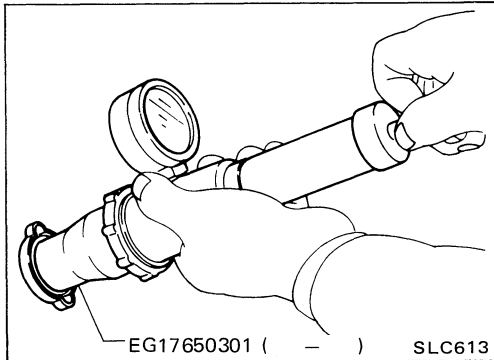

CHECKING RADIATOR CAP

Apply pressure to radiator cap by means of a cap tester to see if it is satisfactory.

Radiator cap relief pressure:

78 - 98 kPa (0.8 - 1.0 kg/cm², 11 - 14 psi)

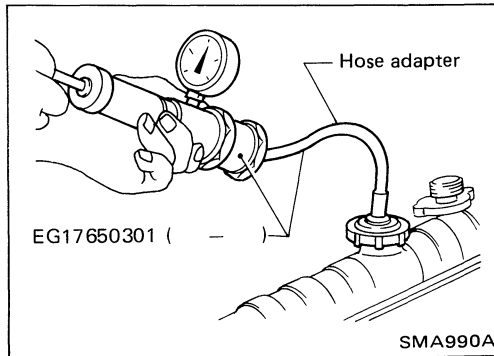

CHECKING COOLING SYSTEM FOR LEAKS

Apply pressure to the cooling system by means of a tester to check for leakage.

Testing pressure:

157 kPa (1.6 kg/cm², 23 psi)

CAUTION:

Higher than the specified pressure may cause radiator damage.

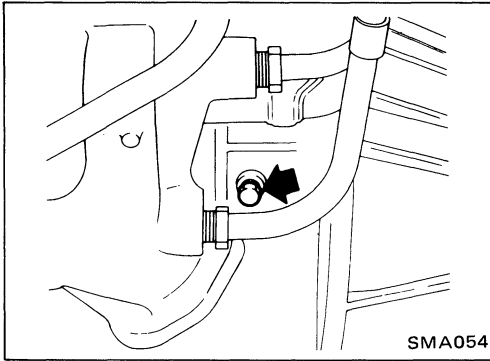

Water Pump

REMOVAL AND INSTALLATION

Drain coolant from drain plug on left rear of cylinder block.

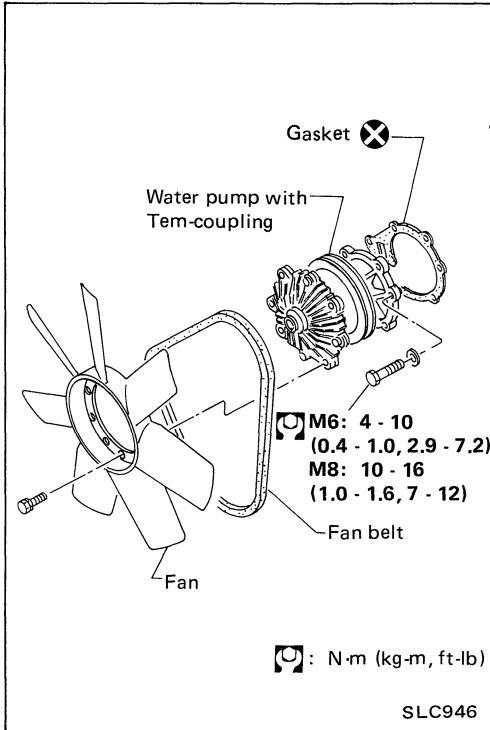

CAUTION:

- When removing water pump assembly, be careful not to get coolant on timing belt.
- Water pump cannot be disassembled and should be replaced as a unit.
- Always replace with new gasket.
- To avoid deforming timing cover, make sure there is adequate clearance between cover and hose clamp.
- After installing water pump, connect hose and clamp securely, then check for leaks using radiator cap tester.

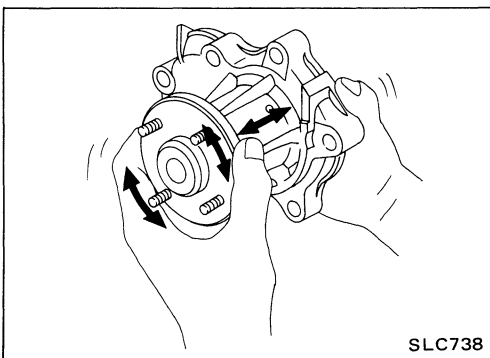

INSPECTION

1. Check for badly rusted or corroded body assembly and vane.
2. Check for rough operation due to excessive end play.

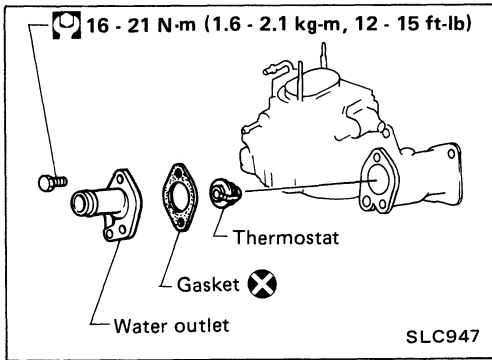

Thermostat

- After installation, run engine for a few minutes, and check for leaks.
- Be careful not to spill coolant over engine compartment. Place a rag to absorb coolant.
- Always replace with new gasket.

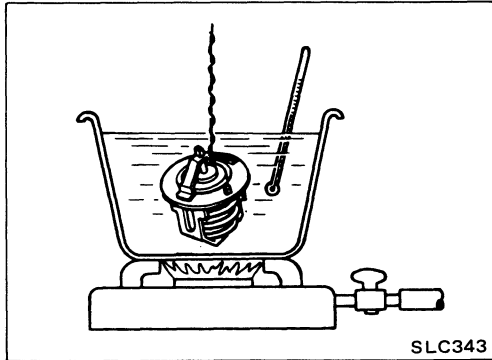

INSPECTION

1. Check valve seating condition at ordinary temperatures. It should seat tightly.
2. Check valve opening temperature and maximum valve lift.

For U.S.A.

	Standard	Frigid type*
Valve opening temperature °C (°F)	82 (180)	88 (190)
Max. valve lift mm/°C (in/°F)	8/95 (0.31/203)	8/100 (0.31/212)

*: Option (Only Federal model)

For Canada

	Standard	Frigid type
Valve opening temperature °C (°F)	88 (190)	—
Max. valve lift mm/°C (in/°F)	8/100 (0.31/212)	—

3. Then check if valve closes at 5°C (9°F) below valve opening temperature.

Radiator

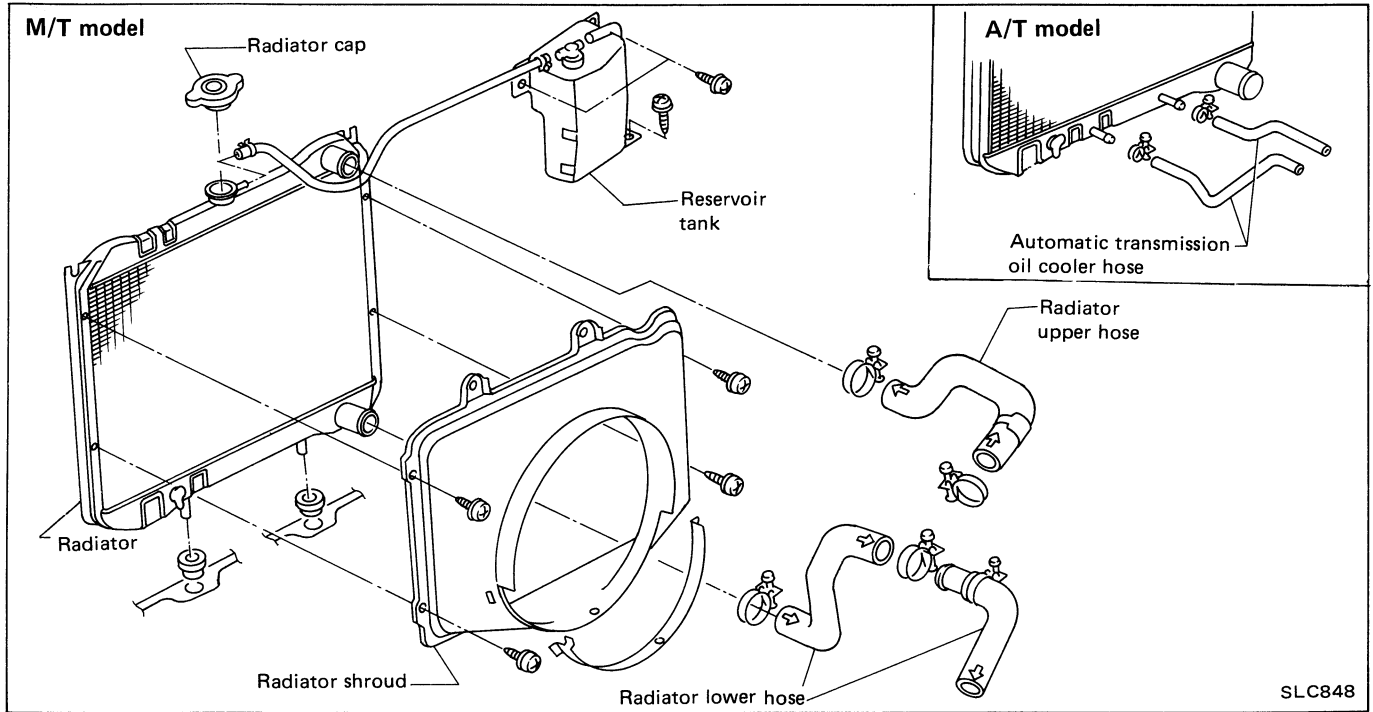

CAUTION:
When filling radiator with coolant, refer to MA section.

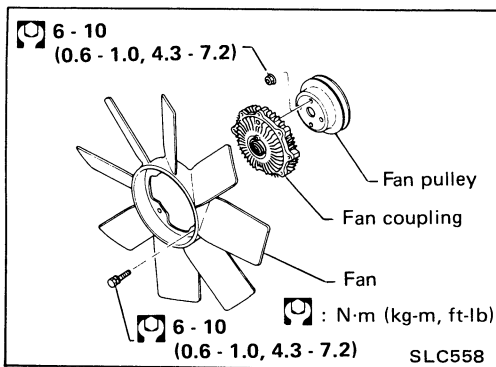

Cooling Fan

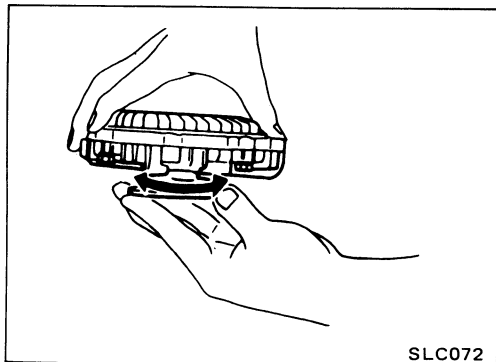

INSPECTION
Check fan coupling for oil leakage or bent bimetal.

Engine Lubrication System

Oil pressure check

Engine rpm	Approximate discharge pressure kPa (kg/cm ² , psi)
Idle speed	More than 73.6 (0.75, 10.7)
3,000	324 - 461 (3.3 - 4.7, 47 - 67)

Oil pump

Unit: mm (in)

Rotor tip clearance	Less than 0.12 (0.0047)
Outer rotor to body clearance	0.15 - 0.21 (0.0059 - 0.0083)
Side clearance (with gasket)	0.04 - 0.08 (0.0016 - 0.0031)

Tightening torque

Unit	N·m	kg·m	ft·lb
Oil pump mounting bolt	11 - 15	1.1 - 1.5	8 - 11
Oil pump cover bolt	6 - 10	0.6 - 1.0	4.3 - 7.2
Regulator valve cap	39 - 49	4.0 - 5.0	29 - 36
Oil pressure switch	10 - 16	1.0 - 1.6	7 - 12

Engine Cooling System

Thermostat

For U.S.A.

	Standard	Frigid type*
Valve opening temperature °C (°F)	82 (180)	88 (190)
Max. valve lift mm/°C (in/°F)	8/95 (0.31/203)	8/100 (0.31/212)

*: Option (Only Federal model)

For Canada

	Standard	Frigid type
Valve opening temperature °C (°F)	88 (190)	—
Max. valve lift mm/°C (in/°F)	8/100 (0.31/212)	—

Radiator

Unit: kPa (kg/cm², psi)

Cap relief pressure	78 - 98 (0.8 - 1.0, 11 - 14)
Leakage test pressure	157 (1.6, 23)

Tightening torque

Unit	N·m	kg·m	ft·lb
Water pump securing bolt			
M6	4 - 10	0.4 - 1.0	2.9 - 7.2
M8	10 - 16	1.0 - 1.6	7 - 12
Fan installing bolt	6 - 10	0.6 - 1.0	4.3 - 7.2
Fan pulley nut	6 - 10	0.6 - 1.0	4.3 - 7.2
Water outlet housing bolt	16 - 21	1.6 - 2.1	12 - 15
Cylinder block drain plug	29 - 39	3.0 - 4.0	22 - 29

ENGINE FUEL & EMISSION CONTROL SYSTEM

SECTION **EF & EC**

EF & EC

CONTENTS

PRECAUTIONS EF & EC- 4

VG30i & Z24i

ENGINE AND EMISSION CONTROL PARTS LOCATION	EF & EC- 5
ELECTRO INJECTION UNIT PARTS LOCATION	EF & EC- 7
E.C.C.S. DIAGRAM	EF & EC- 8
ENGINE AND EMISSION CONTROL SYSTEM CHART	EF & EC- 10
FUEL FLOW SYSTEM DESCRIPTION	EF & EC- 14
AIR FLOW SYSTEM DESCRIPTION	EF & EC- 16
E.C.C.S. CIRCUIT DIAGRAM	EF & EC- 18
E.C.C.S. WIRING DIAGRAM	EF & EC- 20
E.C.C.S. DESCRIPTION	EF & EC- 24
DIAGNOSTIC PROCEDURE	EF & EC- 41
SELF-DIAGNOSIS	EF & EC- 71
ELECTRONIC CONTROL SYSTEM INSPECTION	EF & EC- 92
VG30i	
CRANK ANGLE SENSOR	EF & EC- 94
AIR FLOW METER	EF & EC- 96
CYLINDER HEAD TEMPERATURE SENSOR	EF & EC- 98
IGNITION SIGNAL	EF & EC-100
ENGINE CONTROL UNIT	EF & EC-102
E.G.R. FUNCTION	EF & EC-104
EXHAUST GAS SENSOR	EF & EC-108
EXHAUST GAS TEMPERATURE SENSOR	EF & EC-110
THROTTLE SENSOR	EF & EC-114
INJECTOR LEAK	EF & EC-118
INJECTOR	EF & EC-120
IDLE SWITCH	EF & EC-122
STARTER SWITCH	EF & EC-124
VEHICLE SPEED SENSOR	EF & EC-126
NEUTRAL/CLUTCH/INHIBITOR SWITCH	EF & EC-128

Contents (Cont'd)

LOAD SIGNAL	EF & EC-130
MIXTURE HEATER	EF & EC-132
MIXTURE HEATER RELAY	EF & EC-134
FUEL PUMP	EF & EC-136
FUEL PUMP RELAY	EF & EC-138
POWER SOURCE FOR E.C.U. & GROUND CIRCUIT FOR E.C.U.	EF & EC-140
MAIN RELAY	EF & EC-142
A.I.V. CONTROL	EF & EC-144
IDLE-UP CONTROL	EF & EC-146
Z24i	
CRANK ANGLE SENSOR	EF & EC-148
AIR FLOW METER	EF & EC-150
WATER TEMPERATURE SENSOR	EF & EC-152
IGNITION SIGNAL	EF & EC-154
ENGINE CONTROL UNIT	EF & EC-156
E.G.R. FUNCTION	EF & EC-158
EXHAUST GAS SENSOR	EF & EC-162
EXHAUST GAS TEMPERATURE SENSOR	EF & EC-164
THROTTLE SENSOR	EF & EC-168
INJECTOR LEAK	EF & EC-172
IDLE SWITCH	EF & EC-174
STARTER SWITCH	EF & EC-176
NEUTRAL/CLUTCH/INHIBITOR SWITCH	EF & EC-178
INJECTOR	EF & EC-180
MIXTURE HEATER	EF & EC-182
MIXTURE HEATER RELAY	EF & EC-184
FUEL PUMP	EF & EC-186
FUEL PUMP RELAY	EF & EC-188
POWER SOURCE FOR E.C.U. & GROUND CIRCUIT FOR E.C.U.	EF & EC-190
MAIN RELAY	EF & EC-192
A.I.V. CONTROL	EF & EC-194
IDLE-UP CONTROL	EF & EC-196
SPARK PLUG SWITCHING CONTROL	EF & EC-198
E.C.U. INPUT/OUTPUT SIGNAL INSPECTION	EF & EC-200
MIXTURE RATIO FEEDBACK SYSTEM INSPECTION	EF & EC-205
ELECTRO INJECTION UNIT INSPECTION	EF & EC-213
FUEL SYSTEM INSPECTION	EF & EC-217
EXHAUST EMISSION CONTROL SYSTEM	EF & EC-223
EVAPORATIVE EMISSION CONTROL SYSTEM	EF & EC-224
E.G.R. SYSTEM INSPECTION	EF & EC-226
AUTOMATIC TEMPERATURE CONTROL (A.T.C.) SYSTEM	EF & EC-228
CRANKCASE EMISSION CONTROL SYSTEM	EF & EC-230
A.I.V. SYSTEM INSPECTION	EF & EC-231
SERVICE DATA AND SPECIFICATIONS (S.D.S.)	EF & EC-234

Contents (Cont'd)

When you read wiring diagrams:

- Read GI section, "HOW TO READ WIRING DIAGRAMS".
- See EL section, "POWER SUPPLY ROUTING" for power distribution circuit.

PRECAUTIONS

- Do not operate the fuel pump when the fuel lines are empty.
- Tighten fuel hose clamps to the specified torque.

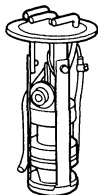

- Always use a 12-volt battery as power source.
- Do not attempt to disconnect the battery cables while the engine is running.

- When installing a C.B. ham radio or a mobile phone, be sure to observe the following notes as it may adversely affect the electronic control systems depending on its installation location.

1) Keep the antenna as far as possible away from the electronic control unit.

2) Keep the antenna feeder line more than 20 cm (7.9 in) away from the harness of electronic controls.

Do not let them run parallel for a long distance.

3) Adjust the antenna and feeder line so that the standing-wave ratio can be kept smaller.

4) Be sure to ground the radio to vehicle body.

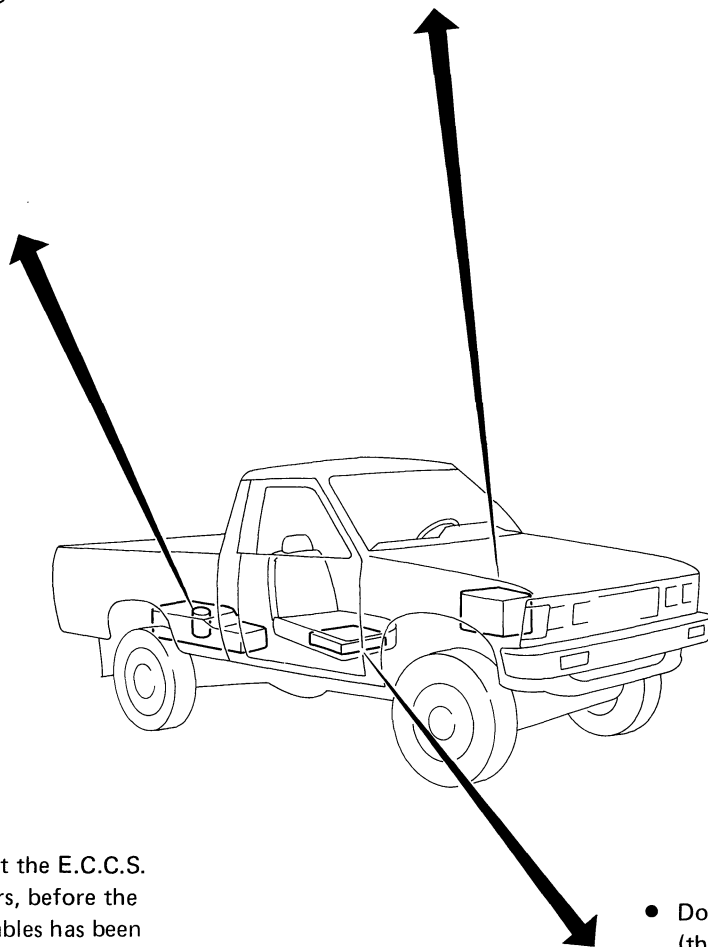
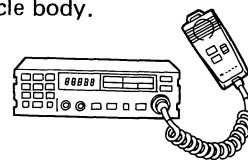

- Do not disconnect the E.C.C.S. harness connectors, before the battery ground cables has been disconnected.
- Securely connect the E.C.C.S. harness connectors.
A poor connection can cause an extremely high (surge) voltage developed in coil and condenser, thus resulting in damage to ICs.
- Keep the E.C.C.S. harness at least 10 cm (3.9 in) away from adjacent harnesses, to prevent an E.C.C.S. system malfunction due to receiving an external noise, degraded operation of ICs, etc.
- Keep E.I. parts and harnesses dry.
- Before removing parts, turn off the ignition switch and disconnect the battery ground cable.
- Do not apply battery voltage to injectors directly, otherwise injectors will be damaged.



- Do not depress the accelerator pedal when starting.
- Immediately after starting, do not rev up the engine unnecessarily.
- Do not rev up the engine just prior to shutdown.

- Do not disassemble the E.C.U. (the E.C.C.S. control unit).

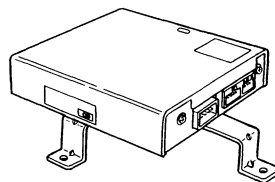

- If a battery terminal is disconnected, the memory will return to the ROM value. The E.C.C.S. will now start to self-control at its initial value. Engine operation can vary slightly when the terminal is disconnected. However, this is not an indication of a problem. Do not replace parts because of a slight variation.

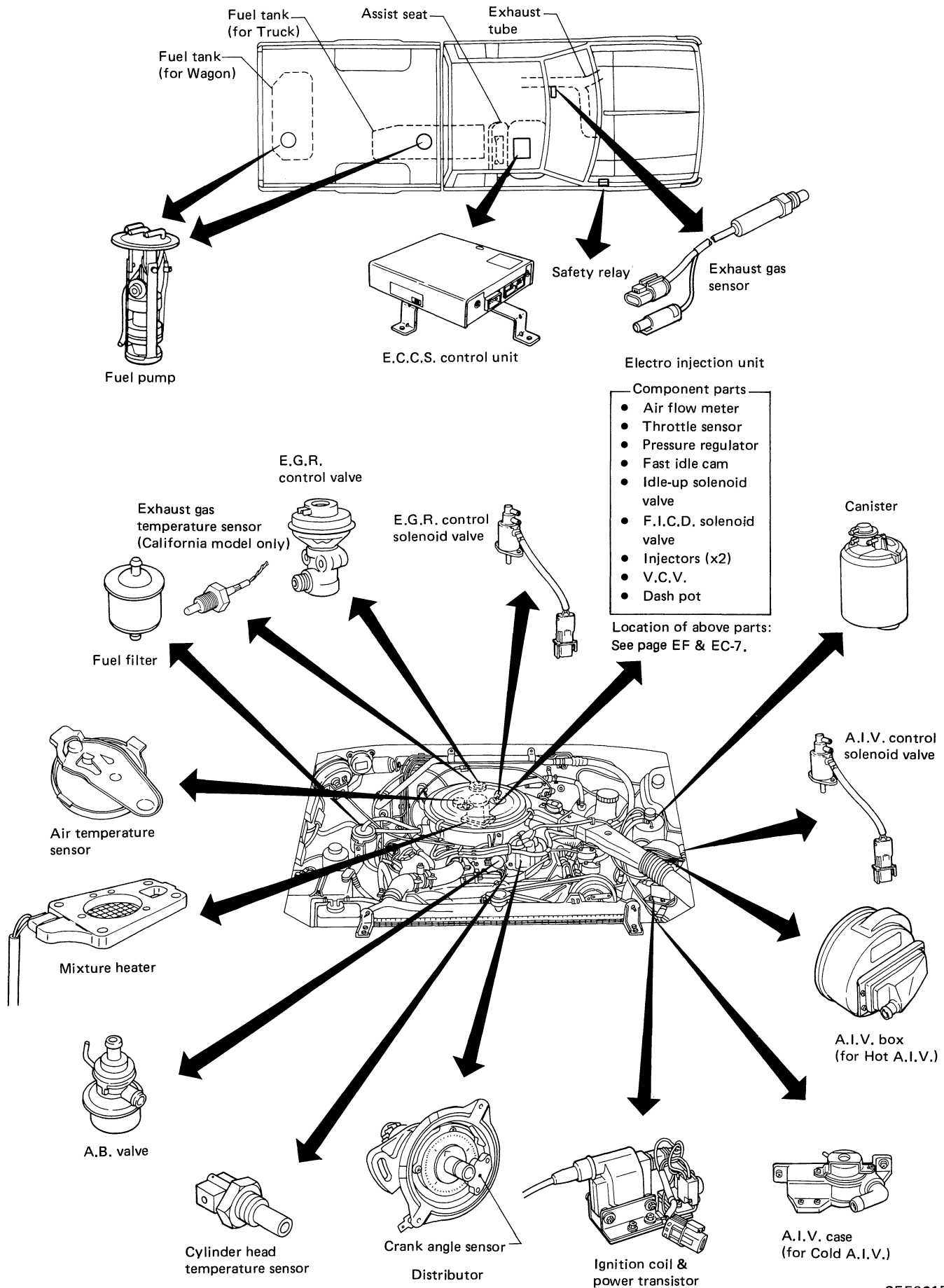

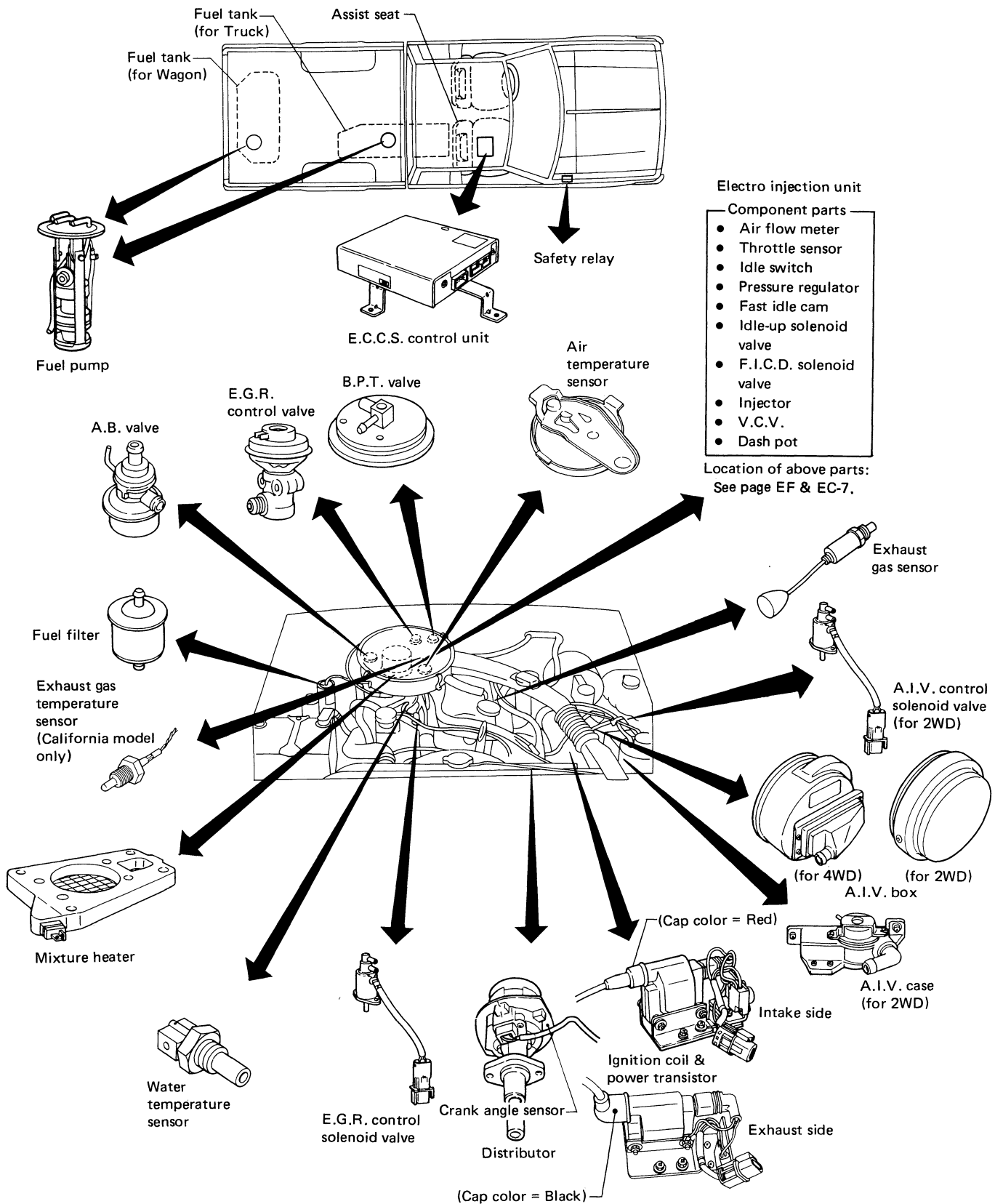

ELECTRO INJECTION UNIT PARTS LOCATION

VG30i

Z24i

Throttle sensor & idle switch

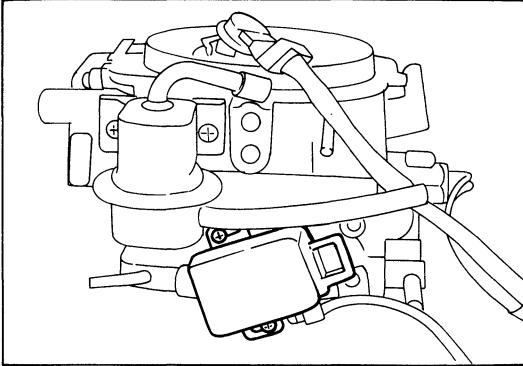

Injector

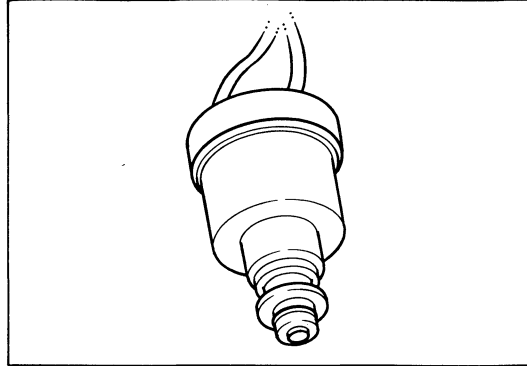

Wax type fast idle cam

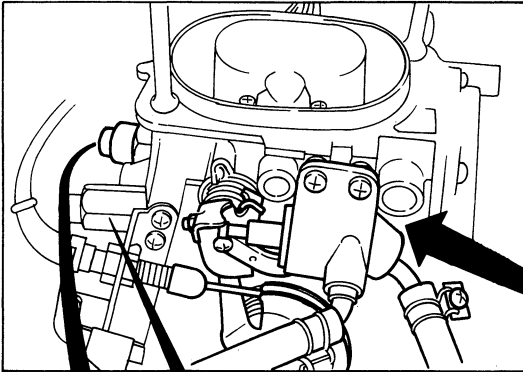

Idle-up solenoid valve
F.I.C.D. solenoid valve

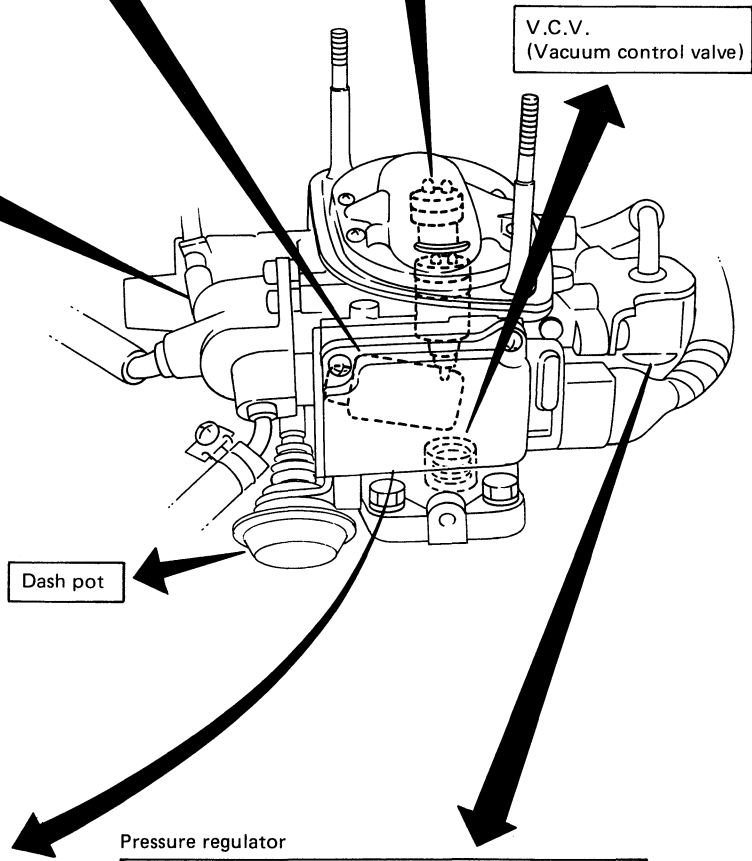
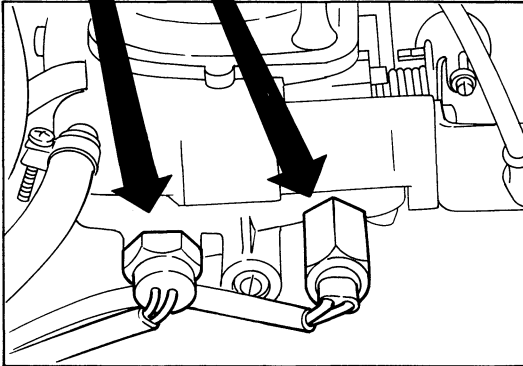

V.C.V.
(Vacuum control valve)

Dash pot

Hot wire type air flow meter

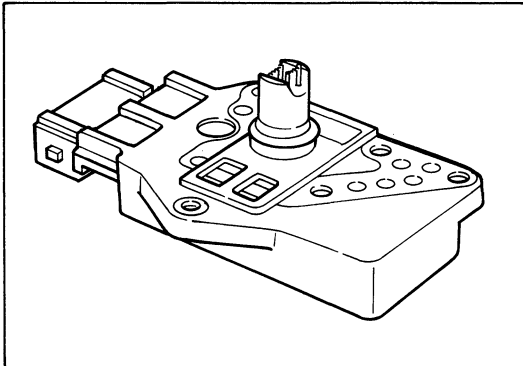

Pressure regulator

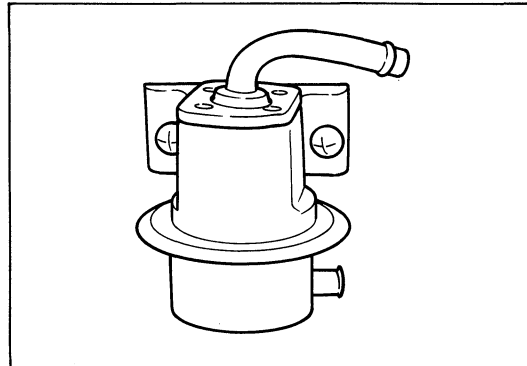

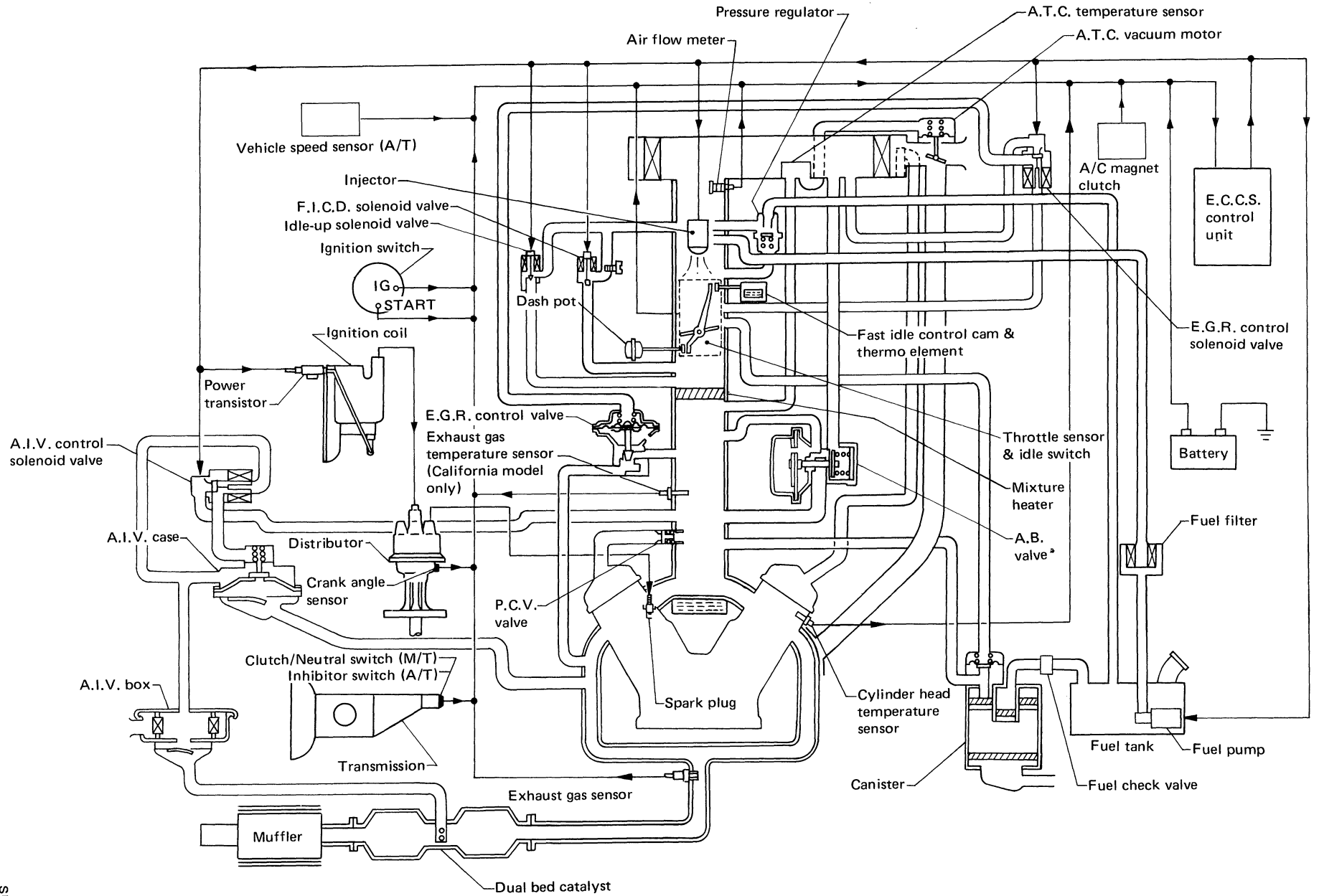

EF & EC-8

SEF385G

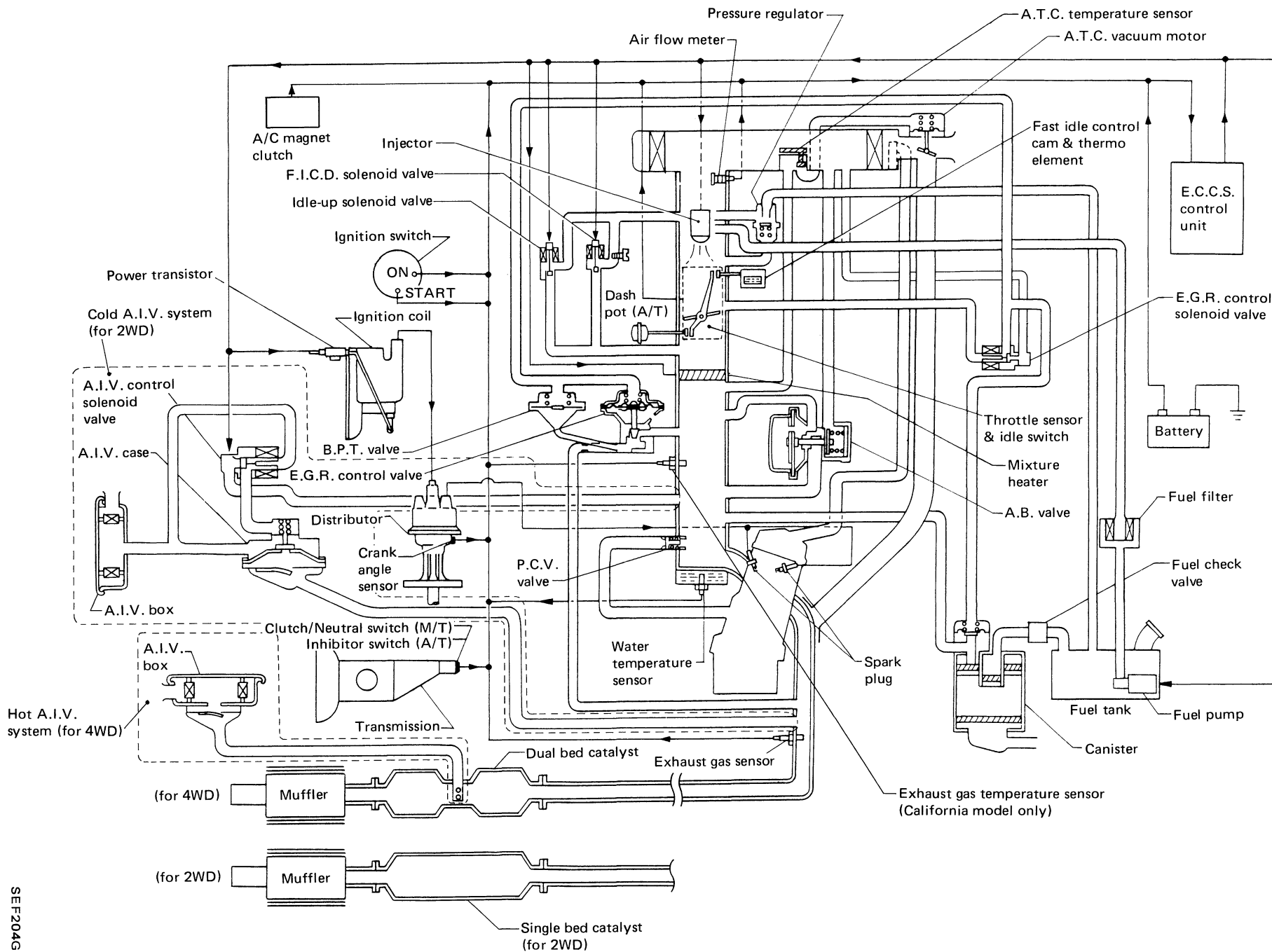

EF & EC-9

SEP204G

E.C.C.S. CONTROL

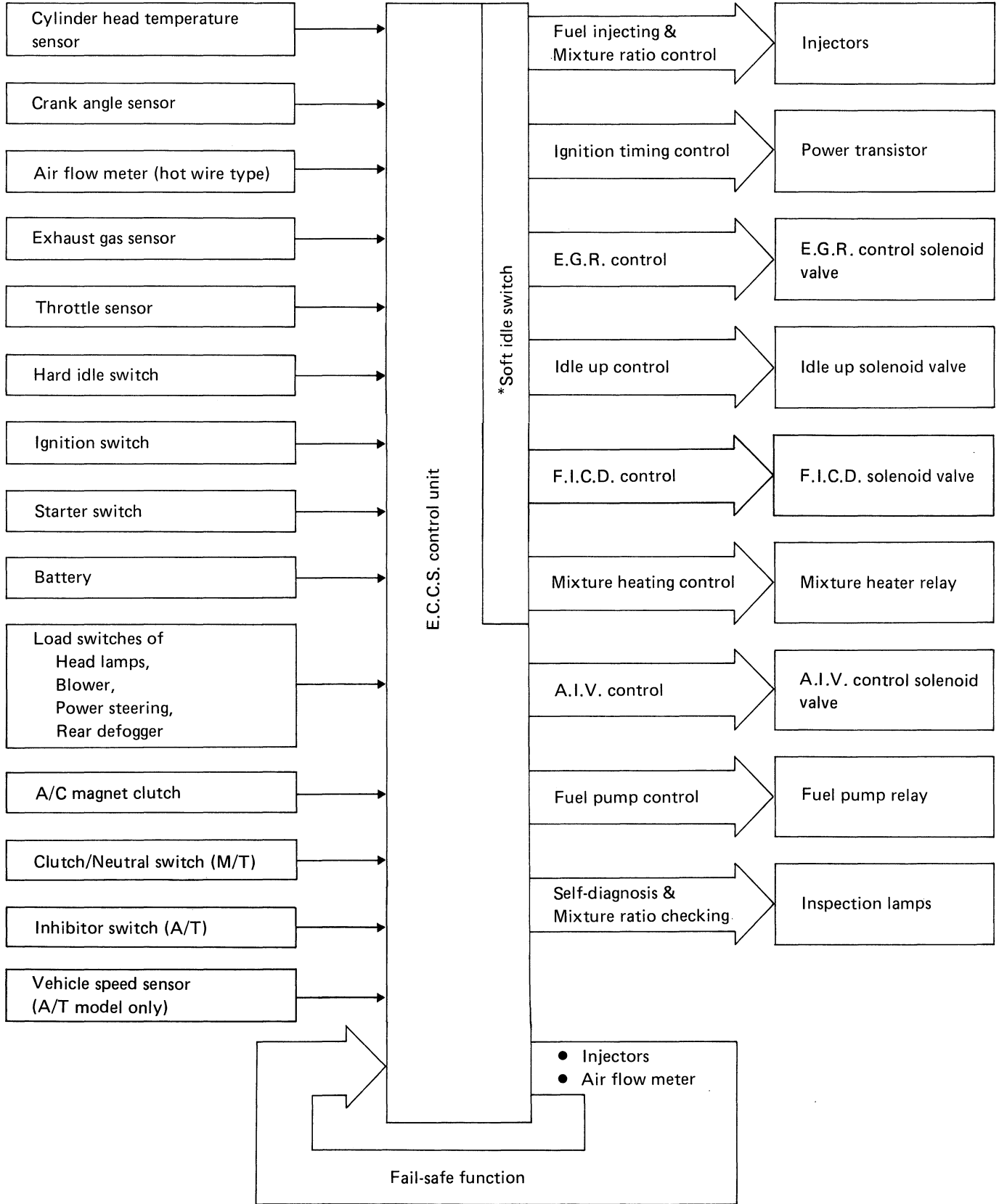

* Idle condition detecting by software

OUT OF E.C.C.S. CONTROL

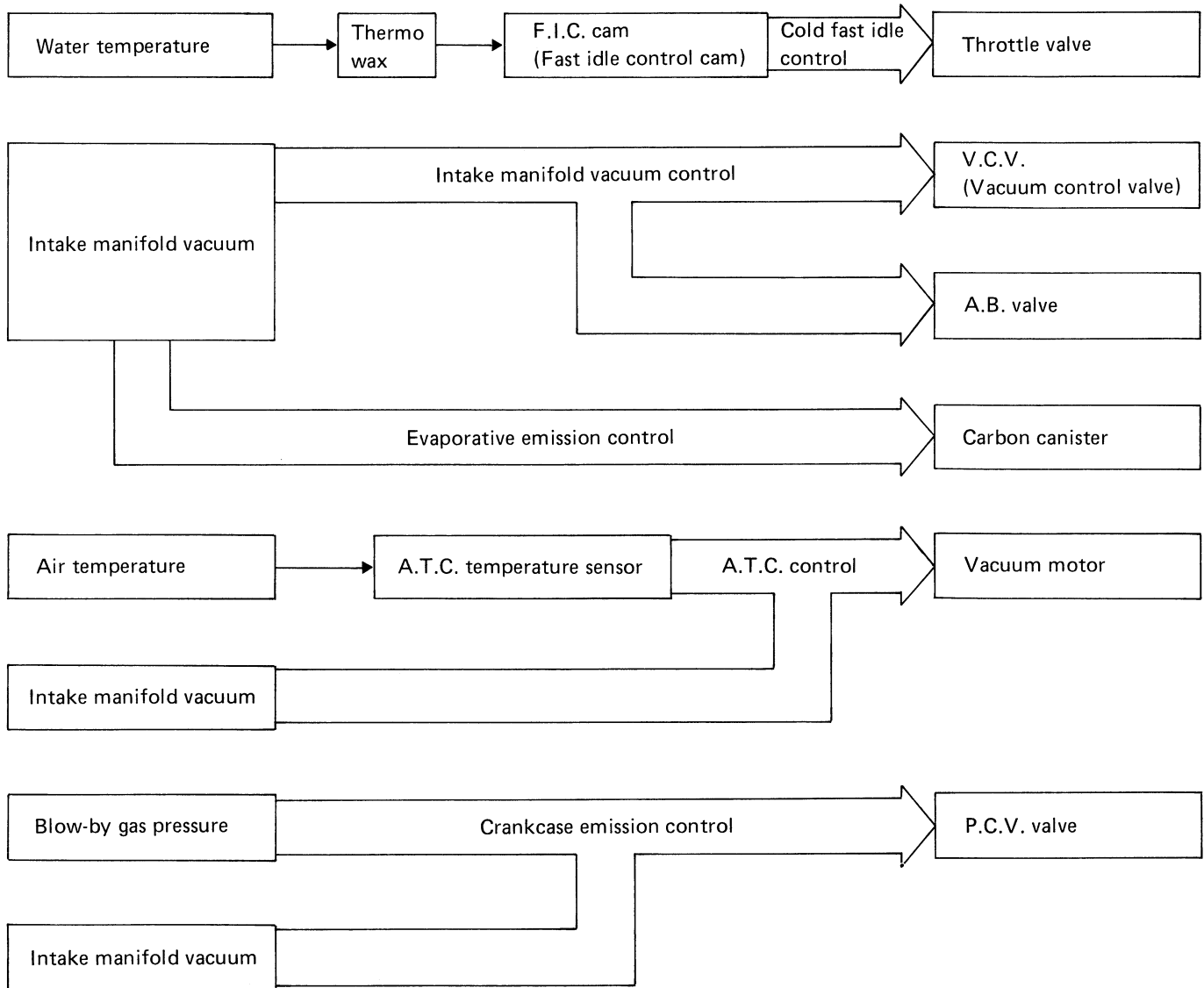

E.C.C.S. CONTROL

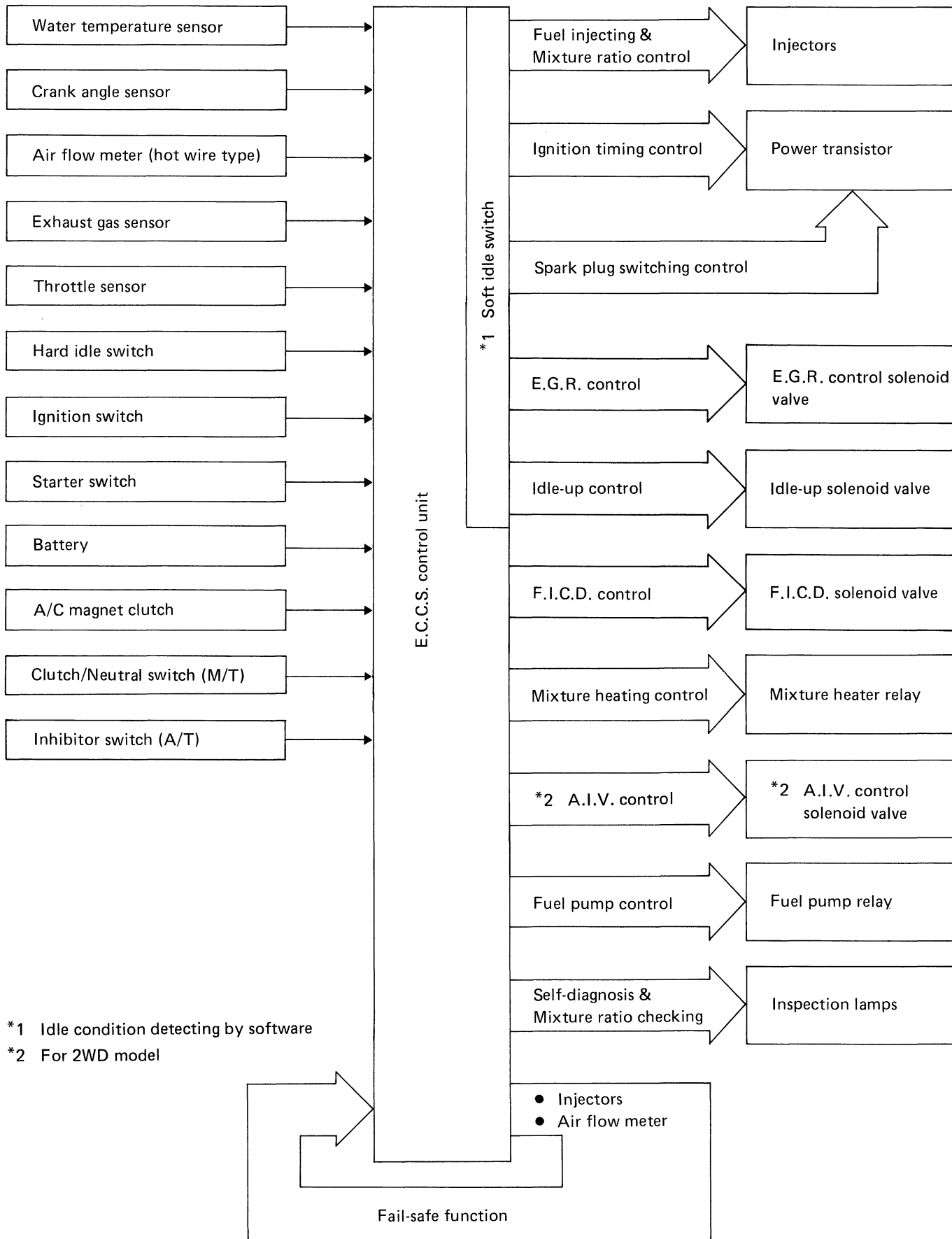

*1 Idle condition detecting by software

*2 For 2WD model

OUT OF E.C.C.S. CONTROL

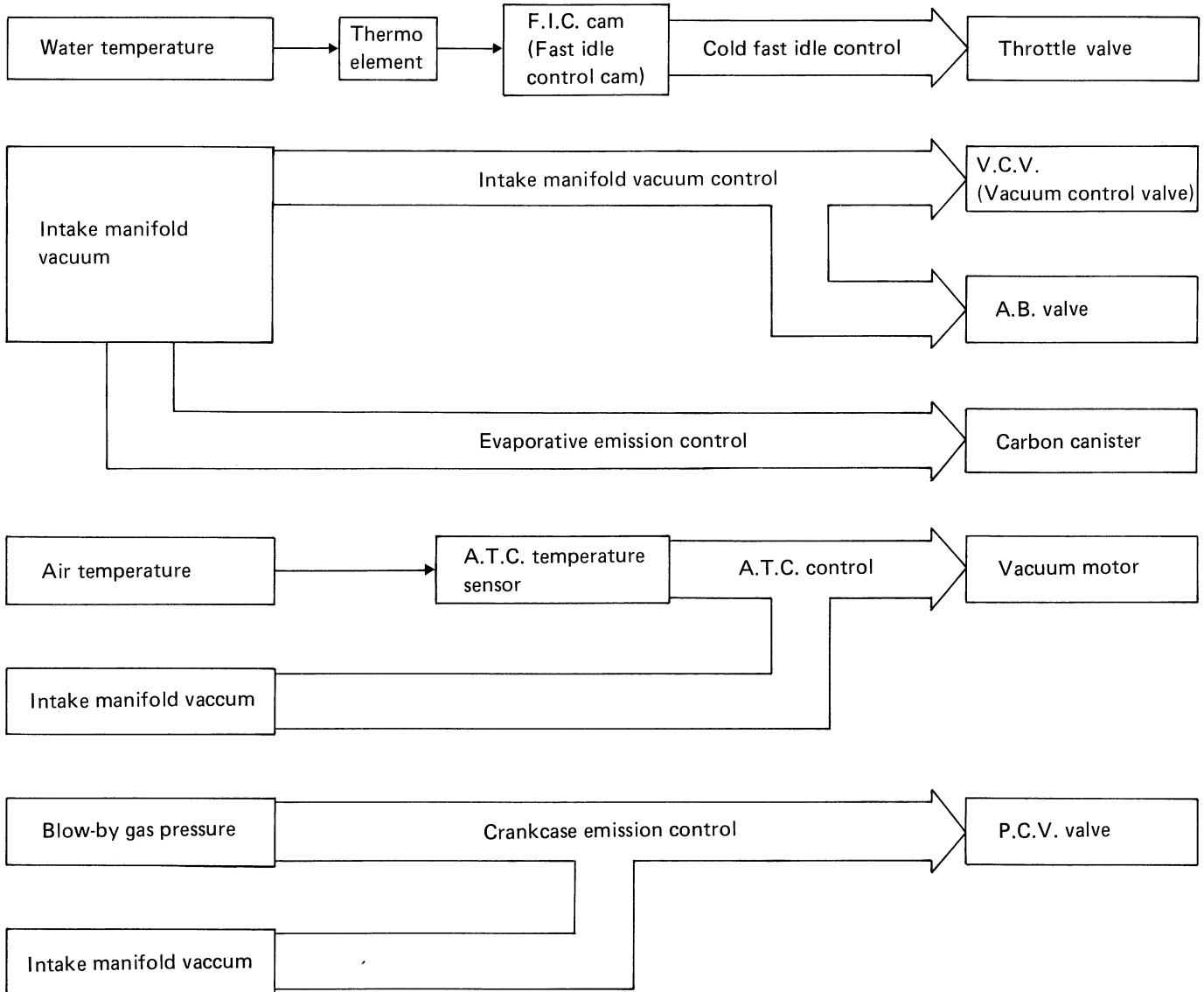

FUEL FLOW SYSTEM DESCRIPTION

VG30i

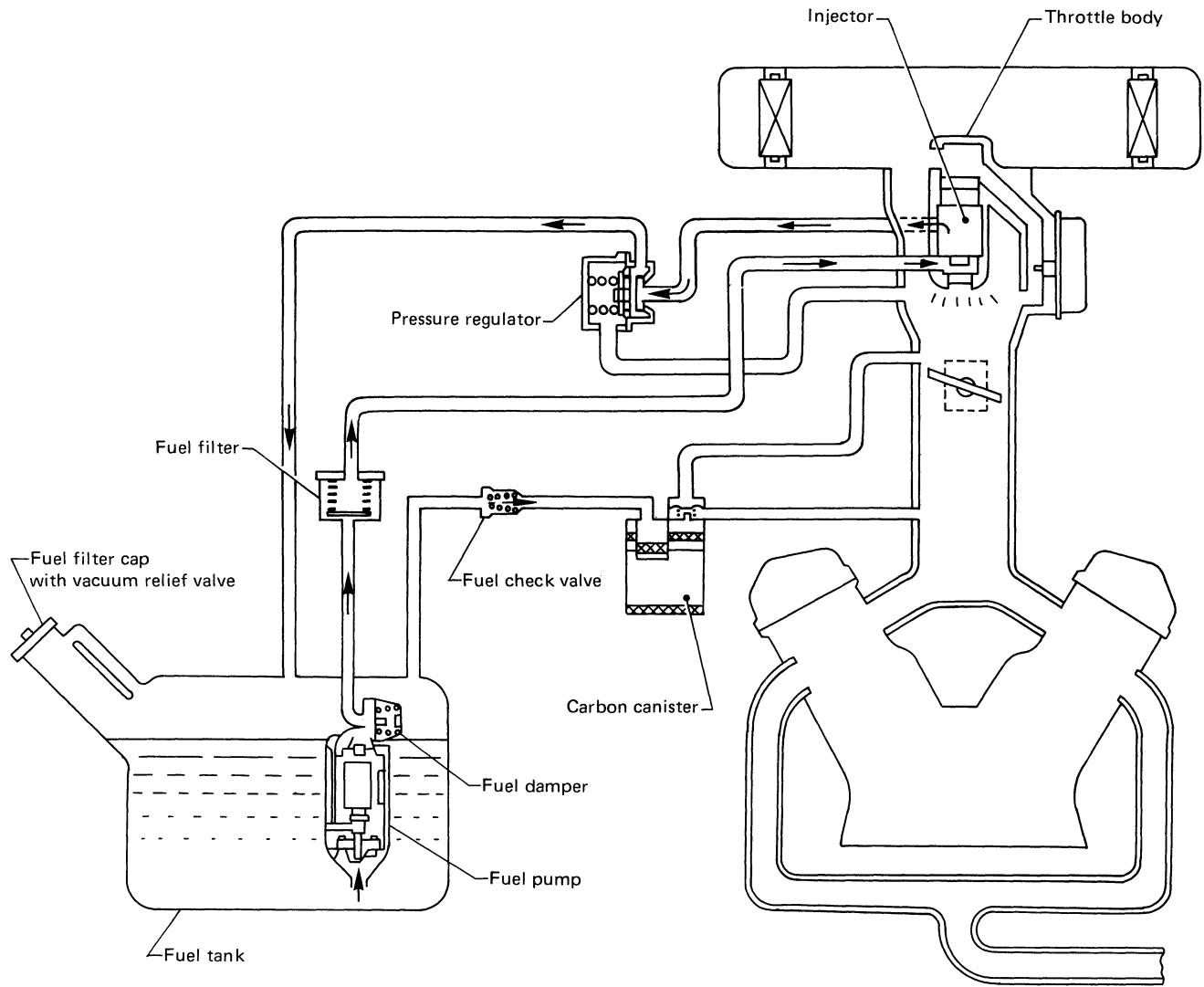

SEF276D

FUEL FLOW SYSTEM DESCRIPTION

Z24i

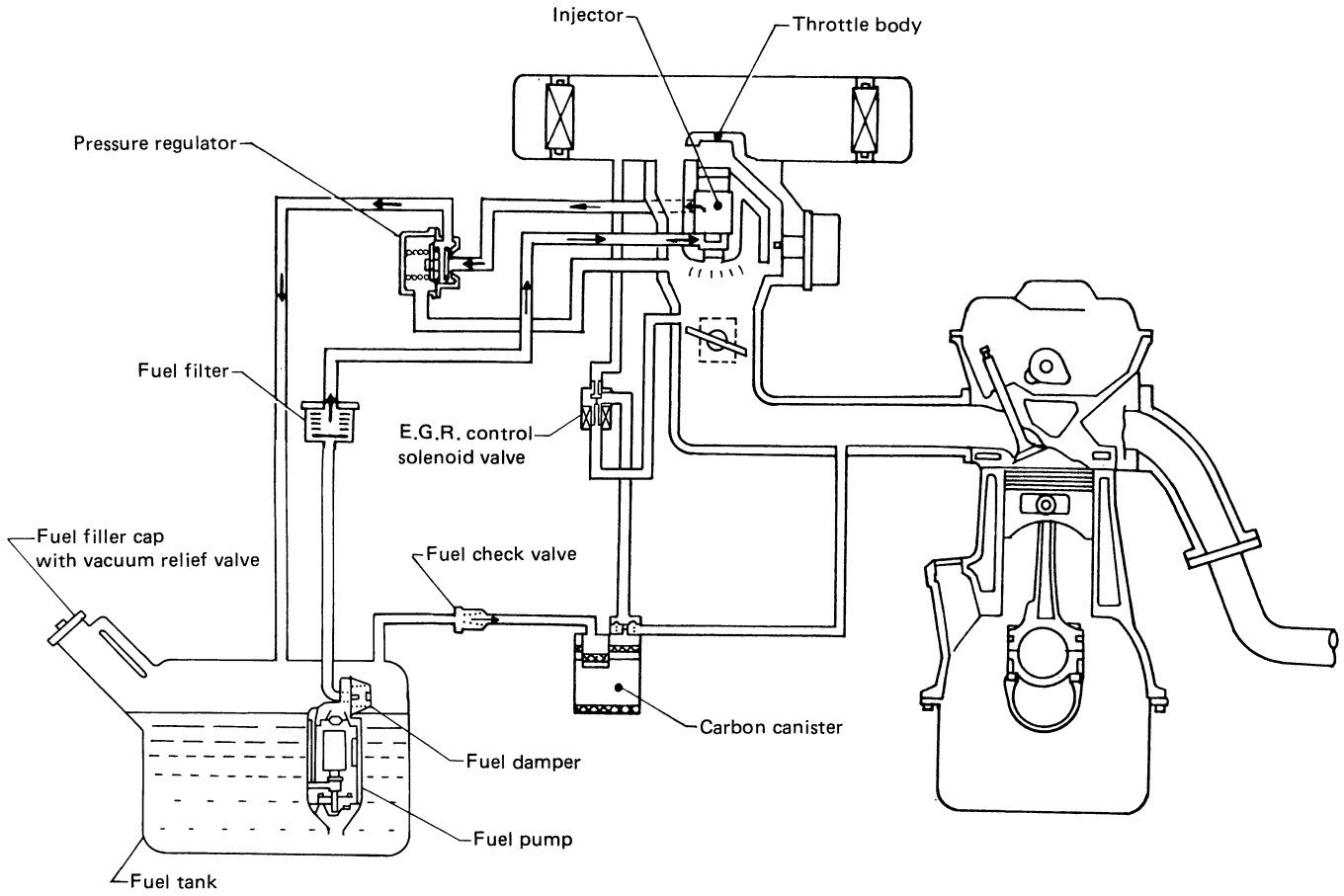

SEF810E

AIR FLOW SYSTEM DESCRIPTION

VG30i

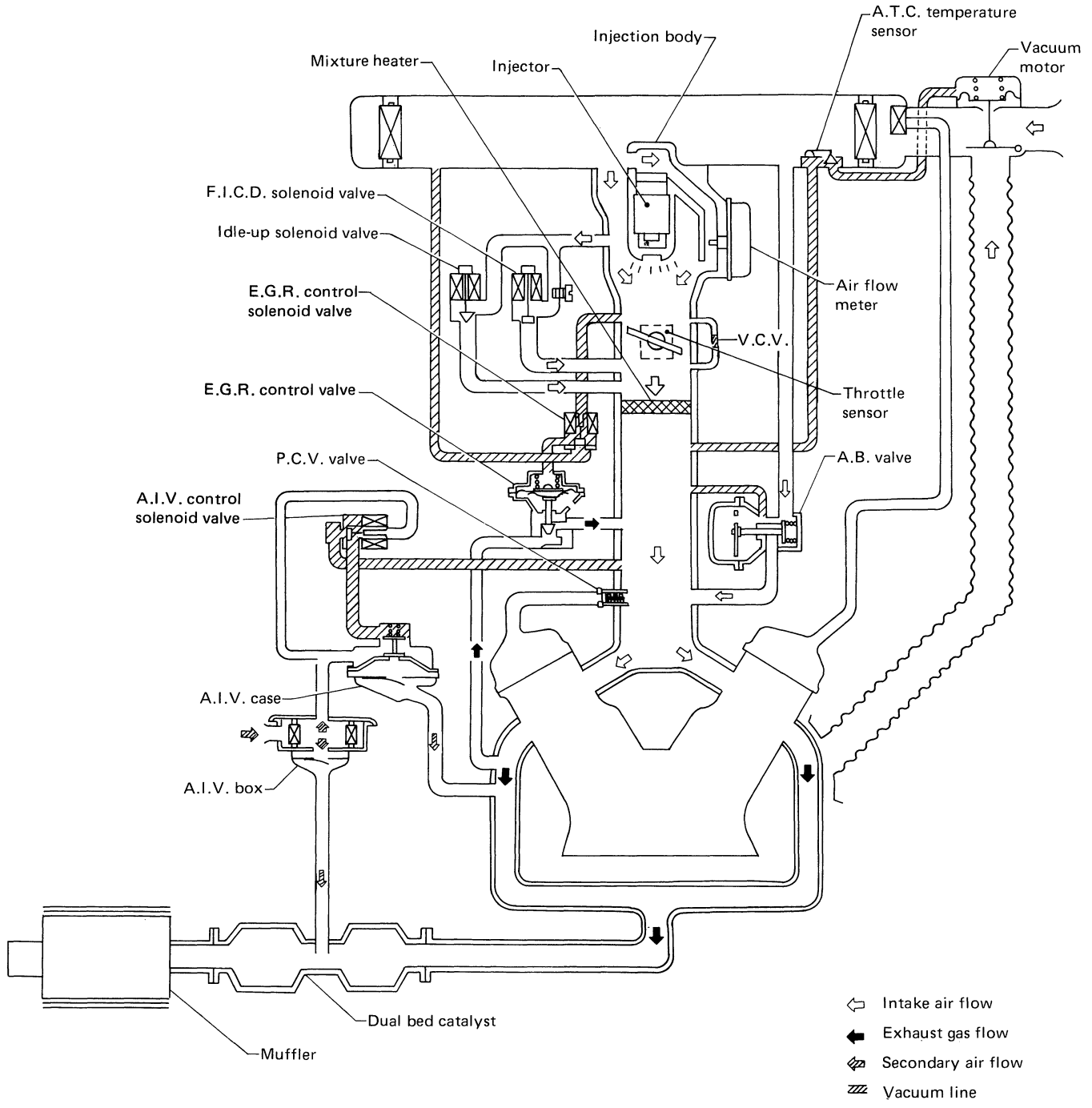

SEF277D

AIR FLOW SYSTEM DESCRIPTION

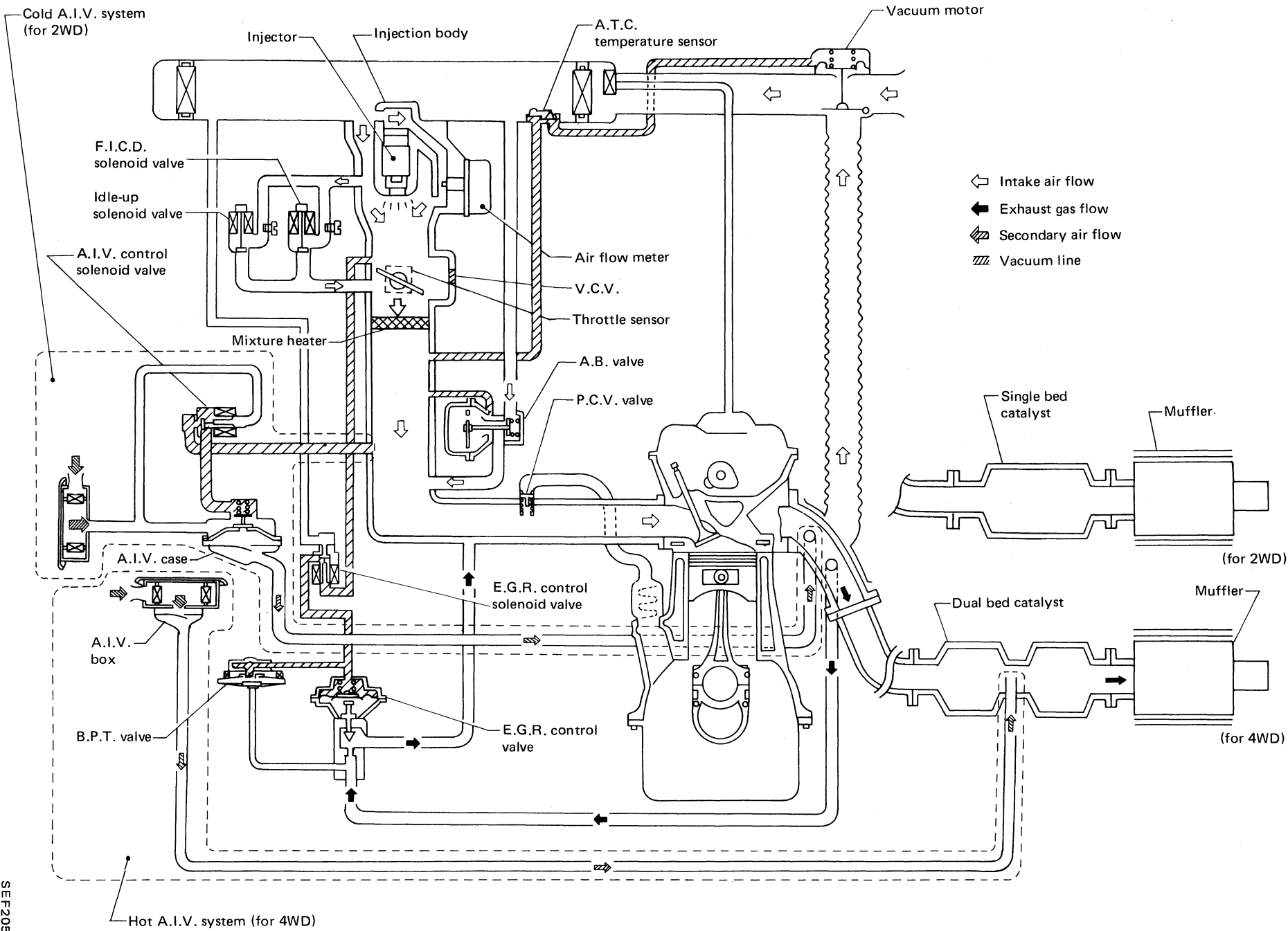

EF & EC-17

SEF205G

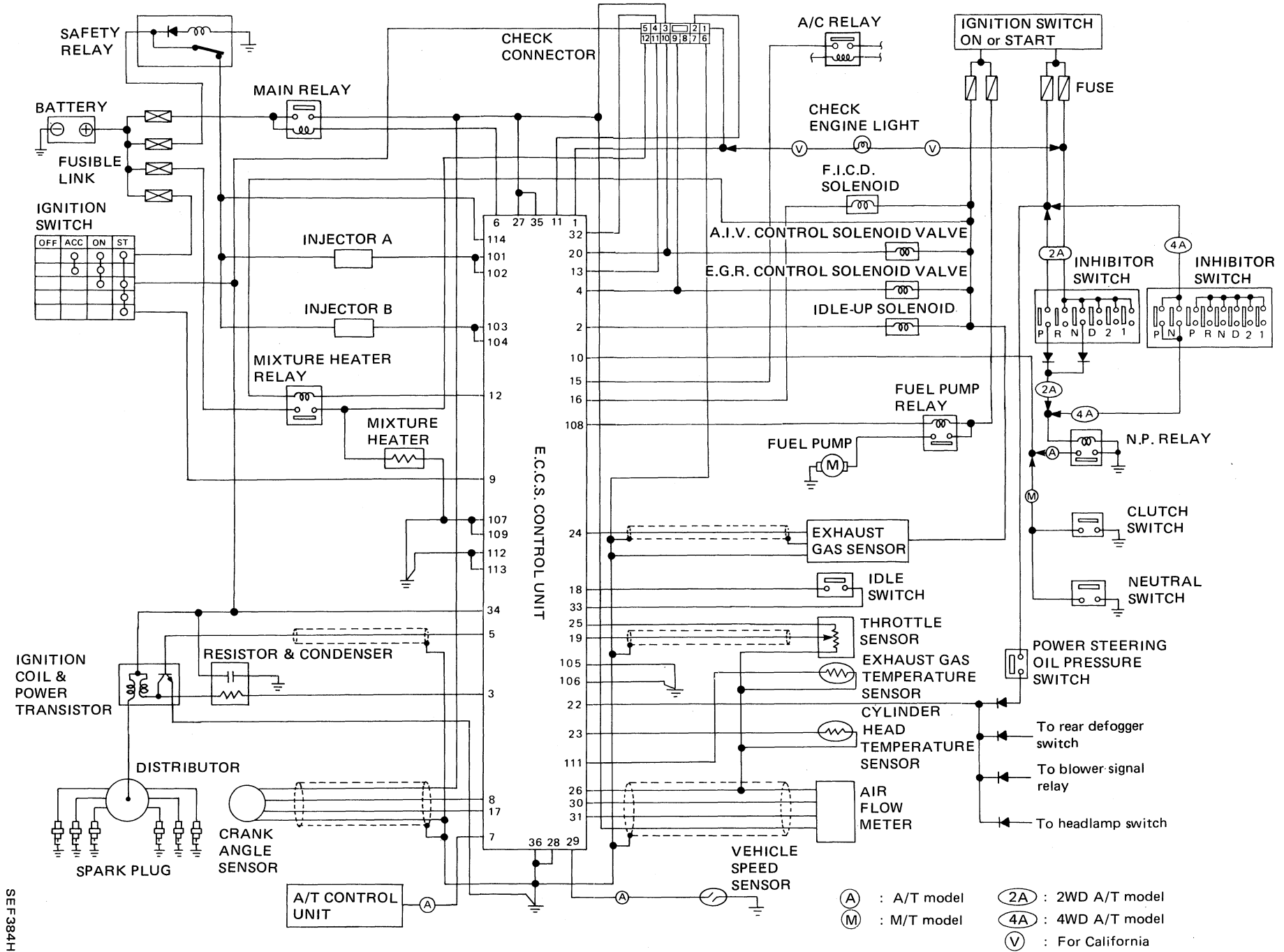

SEF384H

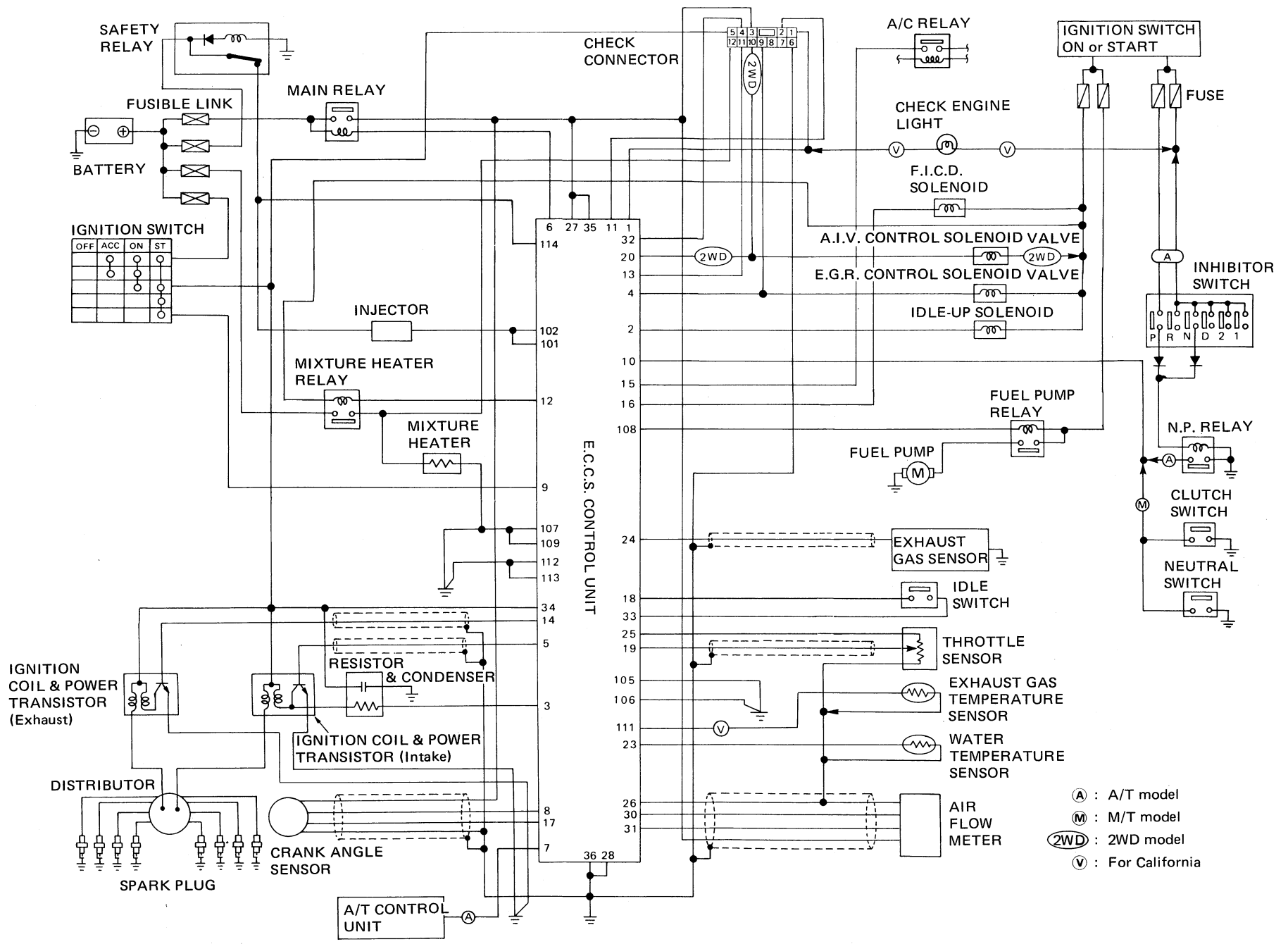

- (A) : A/T model
- (M) : M/T model
- (2WD) : 2WD model
- (V) : For California

EF & EC-19

SEF386H

E.C.C.S. WIRING DIAGRAM

VG30i

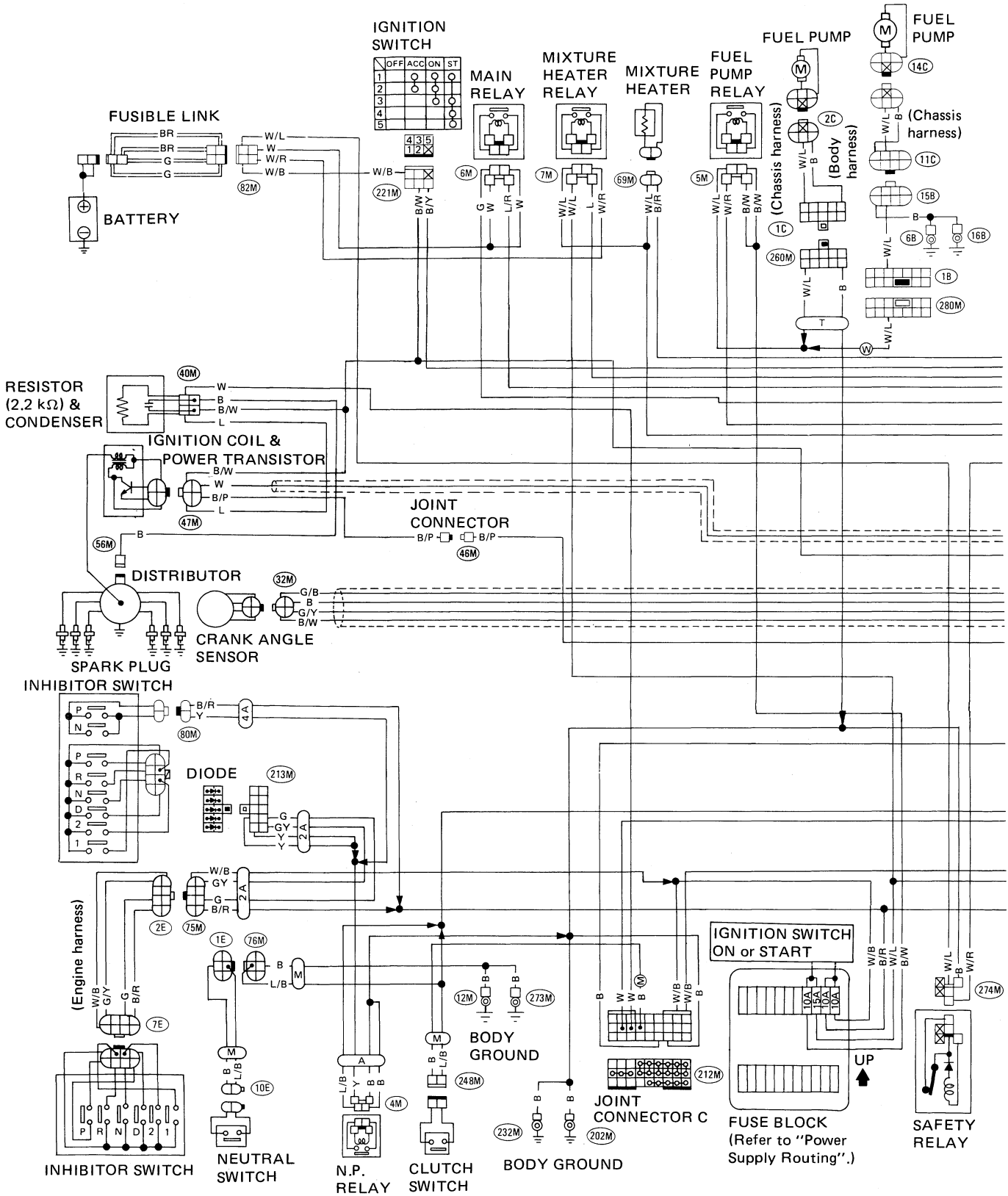

- (V) : For California
- (A) : A/T model
- (M) : M/T model
- (T) : Truck
- (W) : Wagon
- (2A) : 2WD A/T model
- (4A) : 4WD A/T model
- (XE) : E and XE models
- (SE) : SE model

E.C.C.S. WIRING DIAGRAM

VG30i

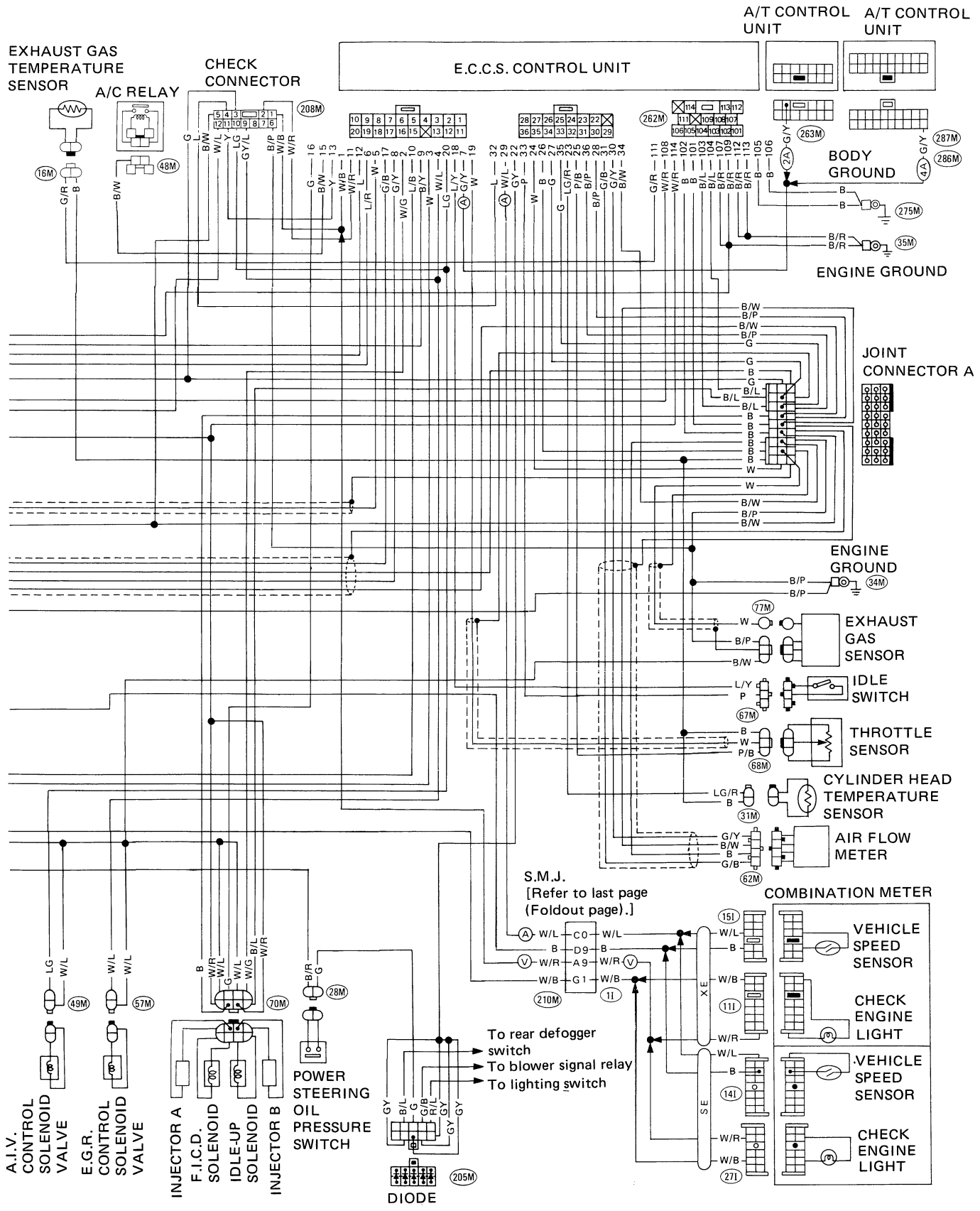

SEF385H

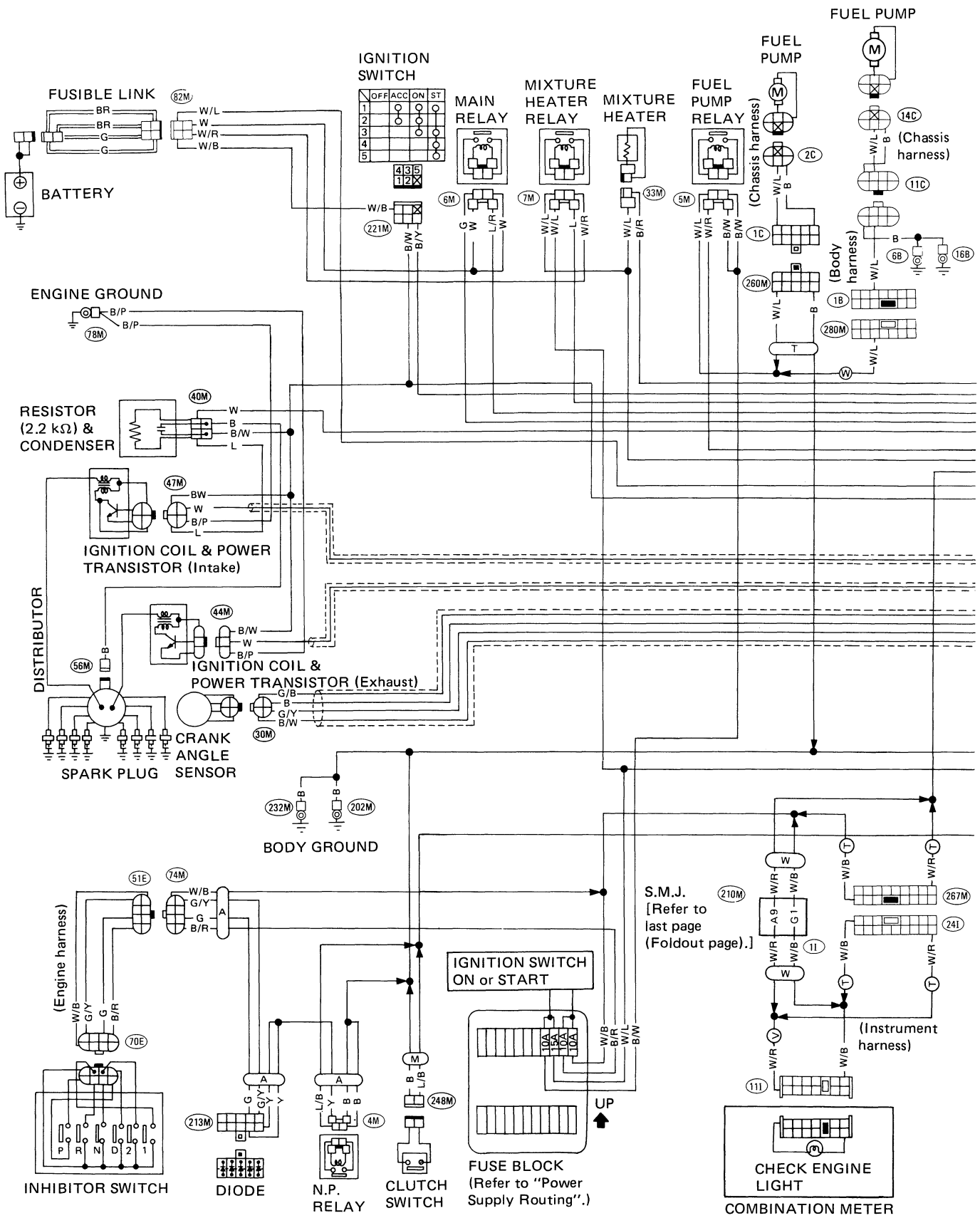

- Ⓓ : Truck
- ⒱ : Van and Wagon
- Ⓐ : A/T model
- Ⓜ : M/T model
- Ⓐ2WD : 2WD model
- Ⓥ : For California

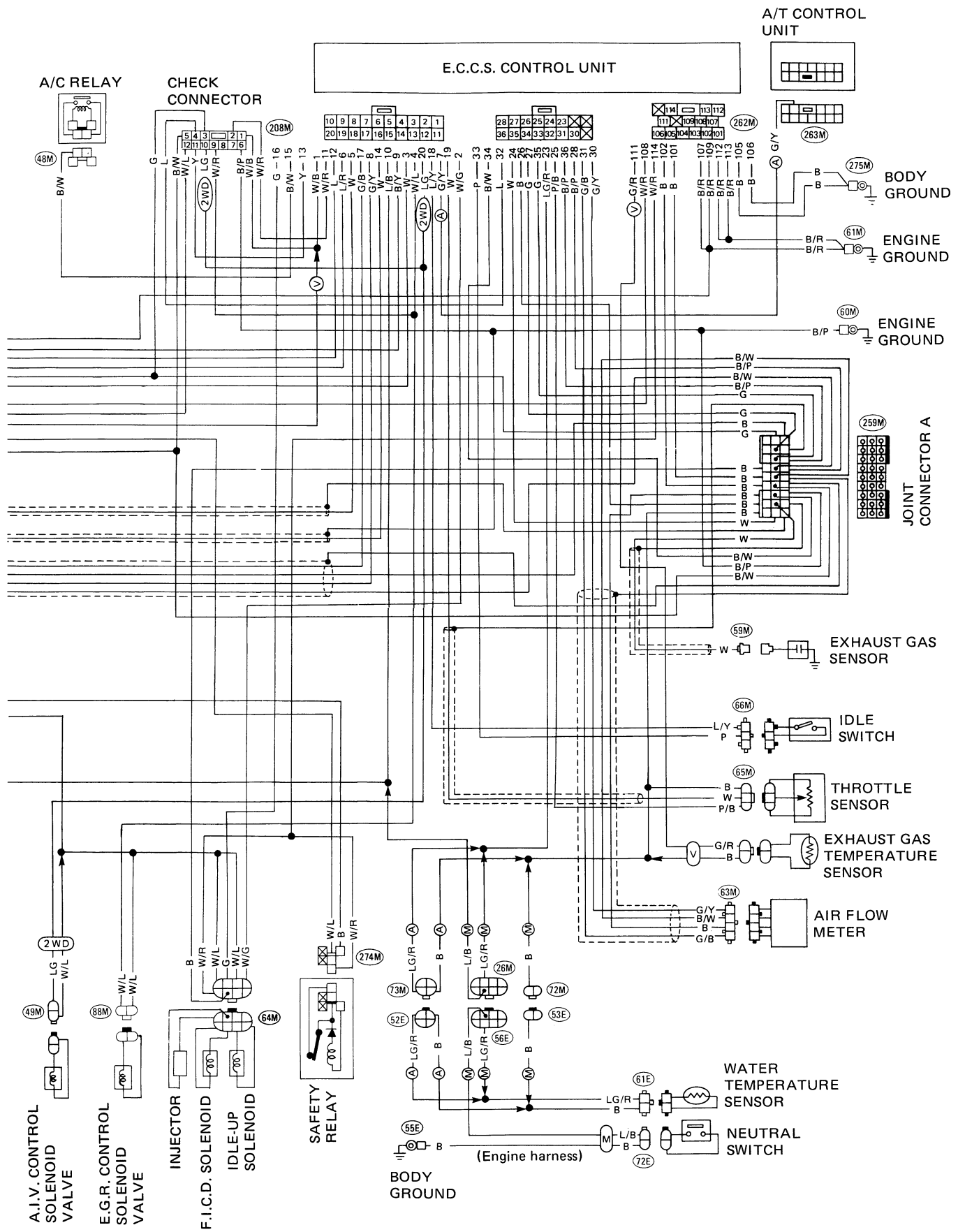

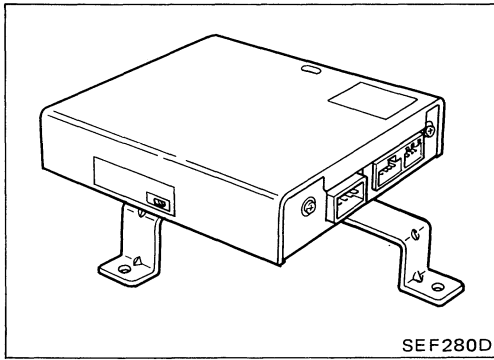

Components

E.C.U. (E.C.C.S. control unit)

The E.C.U. consists of a microcomputer, inspection lamps, a diagnostic mode selector and connectors for signal input and output, and for power supply. The unit has control of the following functions.

- Injected fuel amount
- Ignition timing
- Spark plug switching [Z24i]
- Mixture ratio feedback
- Idle condition detecting
- E.G.R. operation
- Idle-up operation
- F.I.C.D. operation
- Fuel pump operation
- Mixture heating
- A.I.V. operation [VG30i, Z24i(2WD)]
- Self-diagnosis

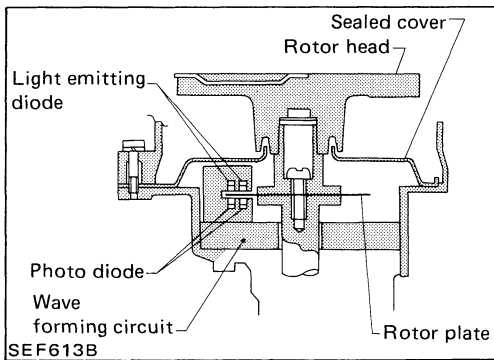

CRANK ANGLE SENSOR

The crank angle sensor is a basic component of the entire E.C.C.S. It monitors engine speed and piston position, and sends to the E.C.U. signals on which the controls of fuel injection, ignition timing and other functions are based.

The crank angle sensor has a rotor plate and a wave forming circuit. The rotor plate has 360 slits for 1° signal and 6 slits for 120° signal [VG30i]/4 slits for 180° signal [Z24i]. Light Emitting Diodes (L.E.D.) and Photo Diodes are built in the wave forming circuit.

When the rotor plate passes the space between the L.E.D. and the Photo Diode, the slits of the rotor plate continually cut the light which is sent to the photo diode from the L.E.D. This causes generating rough-shaped pulses. They are then converted into on-off pulses by the wave forming circuit, which are sent to the E.C.U.

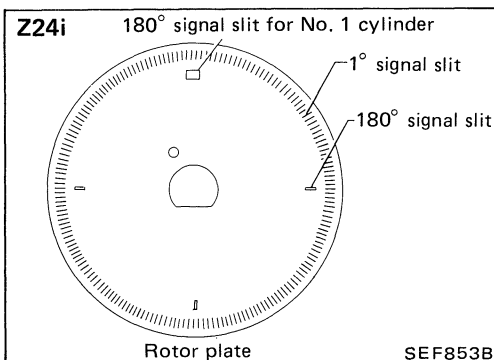
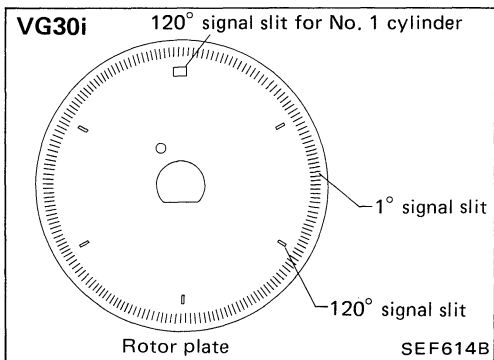

Components (Cont'd)

CYLINDER HEAD TEMPERATURE SENSOR [VG30i]

The cylinder head temperature sensor is also a basic component of the entire E.C.C.S. The sensor, located on the front side of the driver's side cylinder head, detects cylinder head temperature depended on engine coolant temperature and emits signals to the E.C.U.

This part employs a thermistor which is sensitive to changes in temperature. The electric resistance of a thermistor decreases in response to a temperature rise.

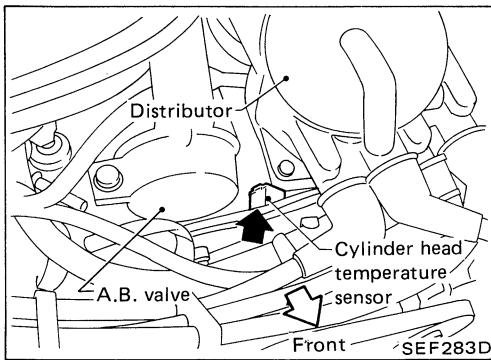

WATER TEMPERATURE SENSOR [Z24i]

The water temperature sensor is also a basic component of the entire E.C.C.S. The sensor, located on the front side of the intake manifold, detects engine coolant temperature and emits signals to the E.C.U.

This part employs a thermistor which is sensitive to changes in temperature. The electric resistance of a thermistor decreases in response to a temperature rise.

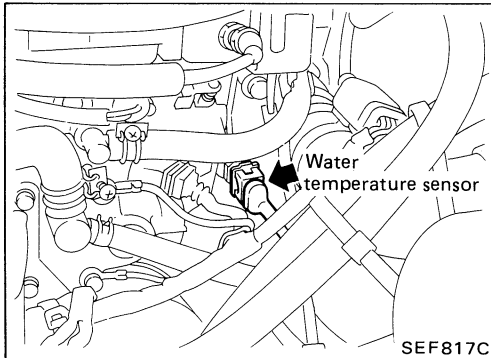

AIR FLOW METER

The air flow meter measures the intake air flow rate by taking a part of the entire flow. Measurements are made in such a manner that the E.C.U. receives electrical output signals varied by the amount of heat emitting from the hot wire placed in the stream of the intake air.

When intake air flows into the intake manifold through a route around the hot wire, the heat generated from the hot wire is taken away by the air. The amount of heat depends on the air flow. On the other hand, the temperature of the hot wire is automatically controlled to a certain number of degrees.

Therefore, it is necessary to supply the hot wire with more electric current in order to maintain the temperature of the hot wire. The E.C.U. knows the air flow by means of the electric change.

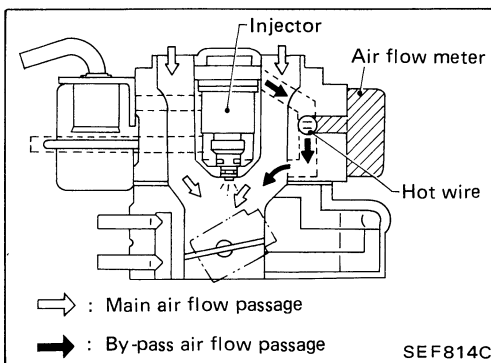

FUEL INJECTOR

The fuel injector is a small, elaborate solenoid valve, to which high-pressure fuel is supplied. The E.C.U. controls the solenoid coil within the injector. The coil, when energized by the E.C.U., opens a ball valve which allows fuel to pass through a swirl orifice and into the manifold. Two injectors are employed in the system.

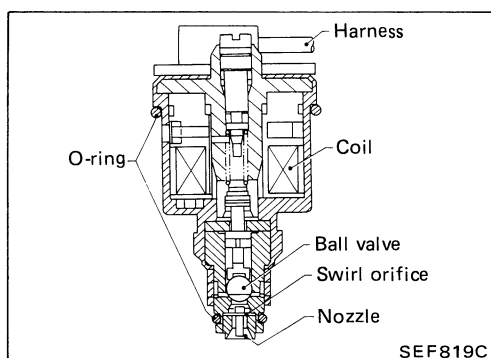

Components (Cont'd)
PRESSURE REGULATOR

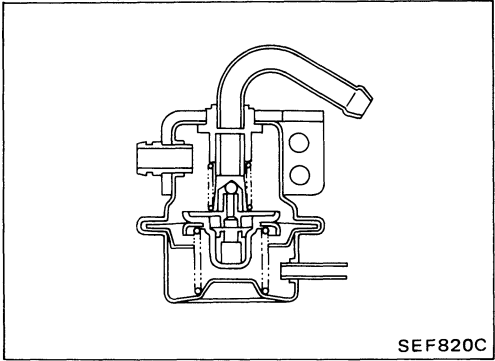

The pressure regulator maintains the fuel pressure at 250.1 kPa (2.55 kg/cm², 36.3 psi). Since the injected fuel amount depends on injection pulse duration, it is necessary to maintain the pressure at the above value.

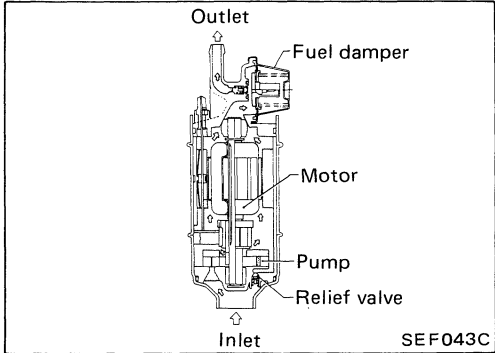

FUEL PUMP

The fuel pump with a fuel damper is an in-tank type, that is the pump and damper are located in the fuel tank. The vane rollers are directly coupled to a motor which is cooled by fuel.

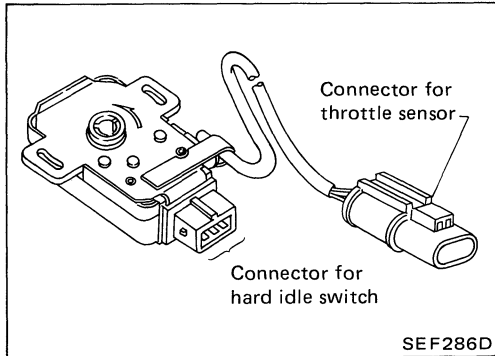

THROTTLE SENSOR & SOFT/HARD IDLE SWITCH

The throttle sensor is attached to the throttle body and actuates in response to the accelerator pedal movement. This sensor is a kind of potentiometer which transforms the throttle valve position into output voltage, and emits the voltage signal to the E.C.U. In addition the sensor detects the opening and closing speed of the throttle valve, and sends the voltage change rate to the E.C.U.

Idle position of the throttle valve is determined by the E.C.U. receiving the signal from the throttle sensor, and the system is called "Soft idle switch". This one controls engine operation such as fuel cut. On the other hand "Hard idle switch", which is built in the throttle sensor unit, is used not for engine control but for self-diagnosis.

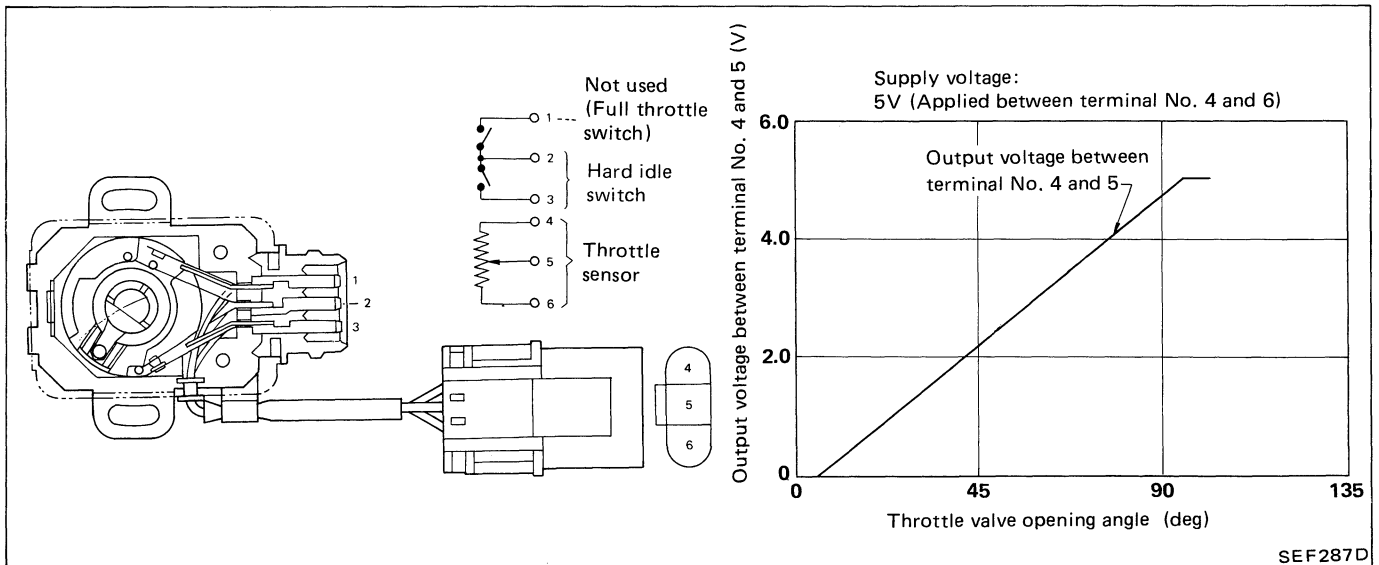

Components (Cont'd)

EXHAUST GAS SENSOR (Titania type) [VG30i]

The exhaust gas sensor, which is placed in the exhaust tube, monitors the amount of oxygen in the exhaust gas.

This sensor is made of ceramic titania which electric resistance drastically changes at the ideal air-fuel ratio.

The E.C.U. supplies the sensor with approximately 1V and takes an output voltage of the sensor depending on its resistance. In order to activate the sensor element, it is equipped with a heater.

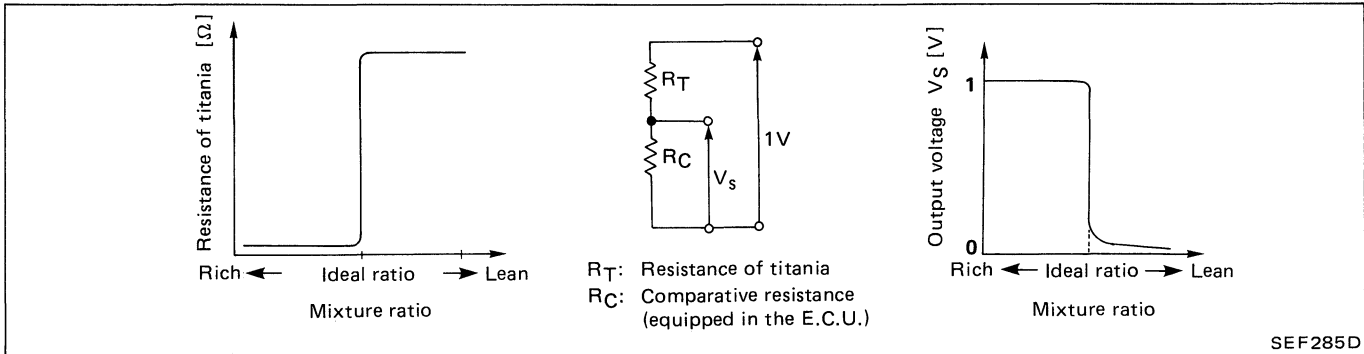
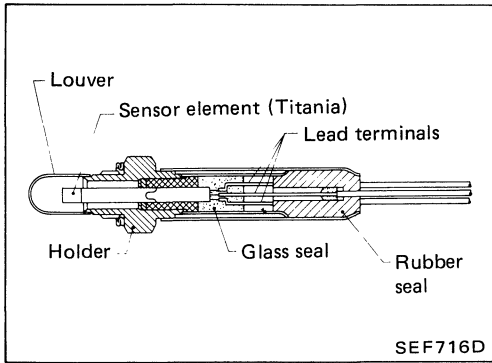

EXHAUST GAS SENSOR (Zirconia type) [Z24i]

The exhaust gas sensor, which is placed into the exhaust manifold, monitors the amount of oxygen in the exhaust gas.

The sensor has a closed-end tube made of ceramic zirconia. The outer surface of the tube is exposed to exhaust gas, and the inner surface to atmosphere. The zirconia of the tube compares the oxygen density of exhaust gas with that of atmosphere, and generates electricity. In order to improve generating power of the zirconia, its tube is coated with platinum. The voltage is approximately 1V in a richer condition of the mixture ratio than the ideal air-fuel ratio, while approximately 0V in leaner conditions. The radical change from 1V to 0V occurs at around the ideal mixture ratio. In this way, the exhaust gas sensor detects the amount of oxygen in the exhaust gas and sends the signal of approximately 1V or 0V to the E.C.U.

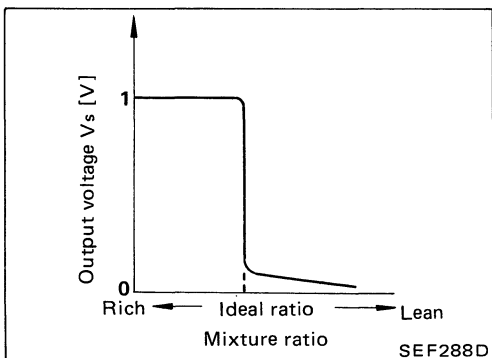
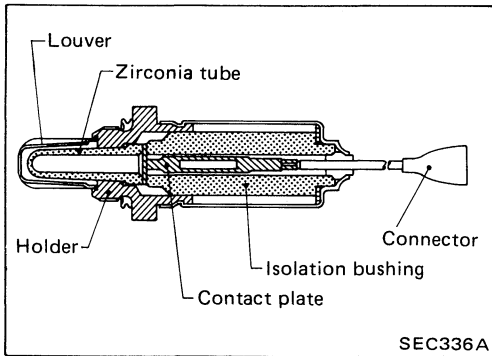

POWER TRANSISTOR & IGNITION COIL

The ignition signal from the E.C.U. is amplified by the power transistor, which turns the ignition coil primary circuit on and off, inducing the proper high voltage in the secondary circuit.

The ignition coil is a small, molded type.

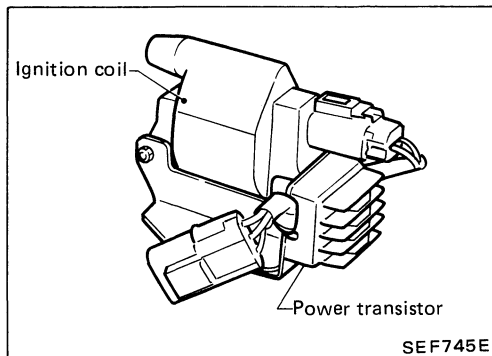

Components (Cont'd)

SAFETY RELAY

The safety relay, which is located behind the right dash side finisher, prevents electrical damage to the E.C.U. and injectors when battery terminals are connected in reverse.

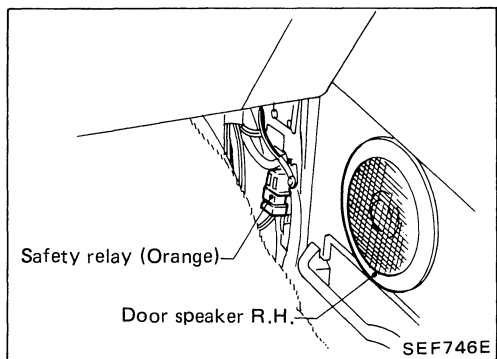

MIXTURE HEATER

The mixture heater is located between the throttle valve and the intake manifold. It is designed to atomize fuel during cold engine start conditions.

The E.C.U. has control of this heater.

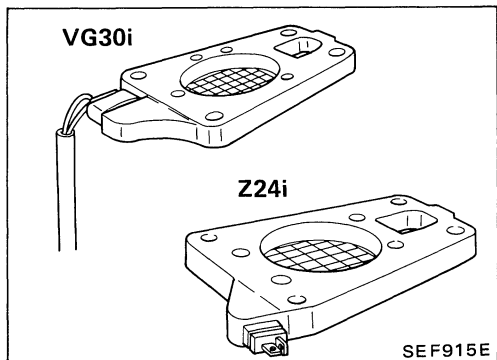

VEHICLE SPEED SENSOR [VG30i]

The vehicle speed sensor provides a vehicle speed signal to the E.C.U. for fuel cut and recovery. This is only for A/T model.

The speed sensor consists of a reed switch, which is installed in the speed meter unit and transforms vehicle speed into a pulse signal.

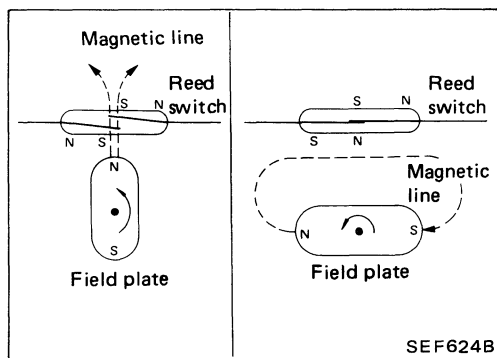

A.I.V. CONTROL SOLENOID VALVE [VG30i, Z24i(2WD)]

This three-port solenoid valve controls the "cold" A.I.V. vacuum line, based on signals supplied by the E.C.U. The second A.I.V. line, called the "hot" line is not controlled by the E.C.U. Refer to A.I.V. description for further details.

E.G.R. CONTROL SOLENOID VALVE

This solenoid valve is the same type as that of A.I.V. The E.G.R. system is controlled only by the E.C.U. At both low and high speed revolution of engine, the solenoid valve turns on and accordingly the E.G.R. control valve cuts the exhaust gas leading to the intake manifold.

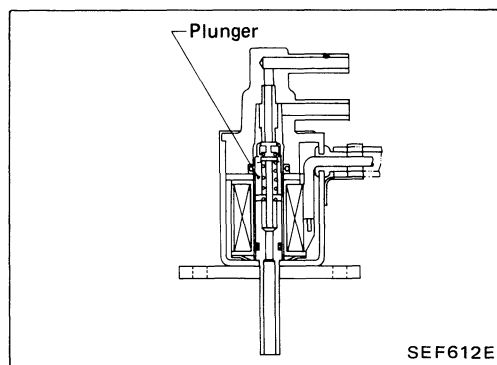

Components (Cont'd)

EXHAUST GAS TEMPERATURE SENSOR

[California model only]

The exhaust gas temperature sensor, located near the E.G.R. control valve, detects the temperatures of exhaust gas from E.G.R. control valve and emits signals to the E.C.U. This sensor employs a thermistor which is sensitive to changes in temperature. The electric resistance of the thermistor decreases in response to a temperature rise.

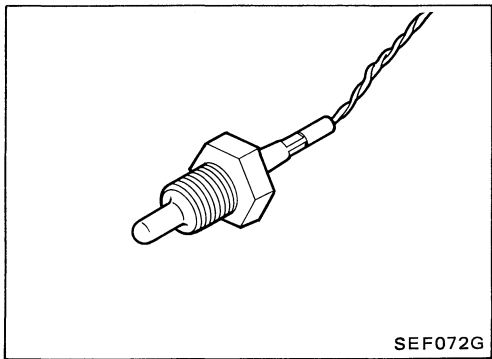

Fuel Injection Control

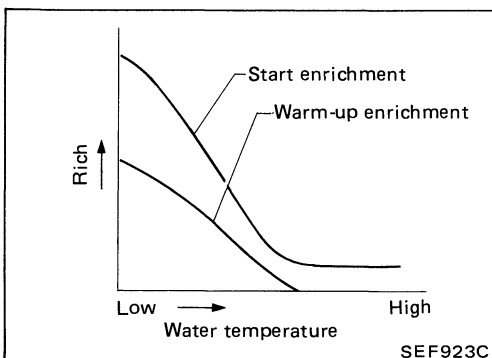
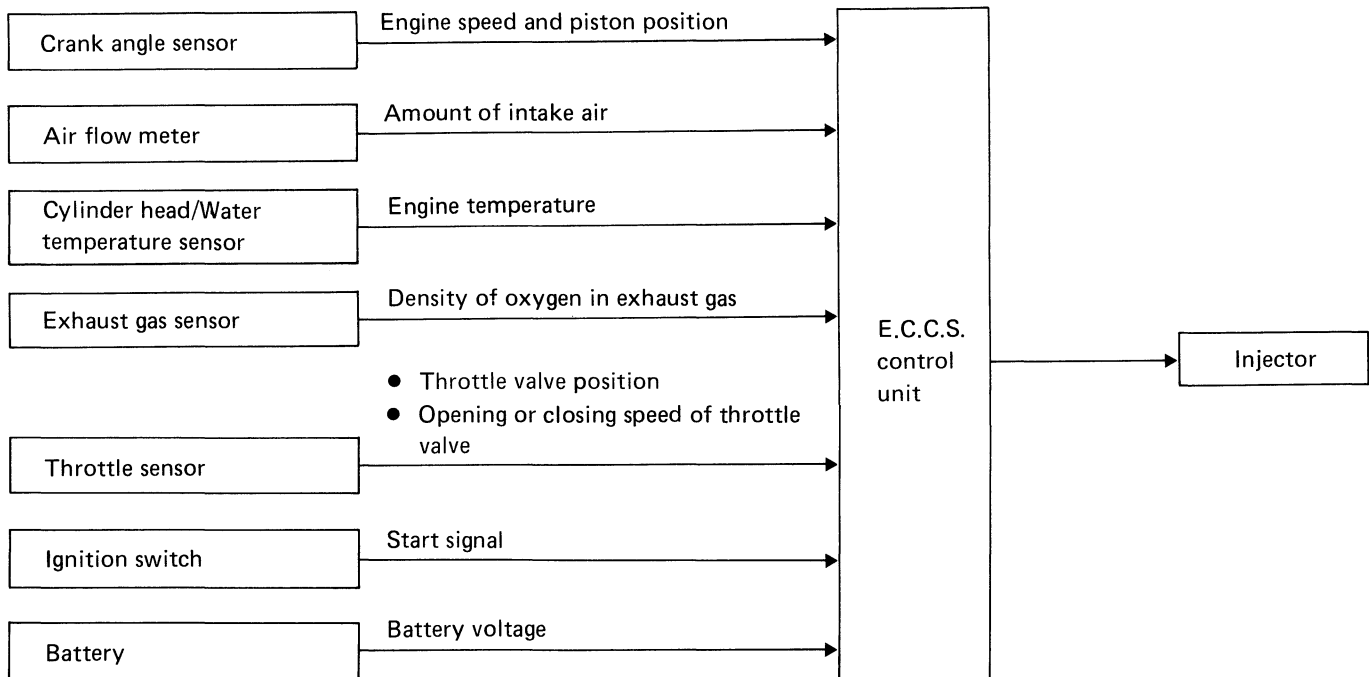

The E.C.U. calculates the basic injection pulse width by processing signals from the crank angle sensor and air flow meter. Receiving signals from each sensor which detects various engine conditions, the E.C.U. adds various enrichments, which are pre-programmed in the E.C.U. to the basic injection amount. Thus, the optimum amount of fuel is injected through the injectors.

1) Fuel enrichment:

In each of the following conditions, fuel is enriched.

- During warm-up
- When starting
- When accelerating (in response to opening speed of throttle valve)
- With heavy load

Enrichment rates for "when accelerating" and "with heavy load" are pre-programmed for engine speed and basic injection pulse width.

2) Fuel lean during deceleration:

Lean rates for "during deceleration" are programmed for closing speed of throttle valve.

Fuel Injection Control (Cont'd)

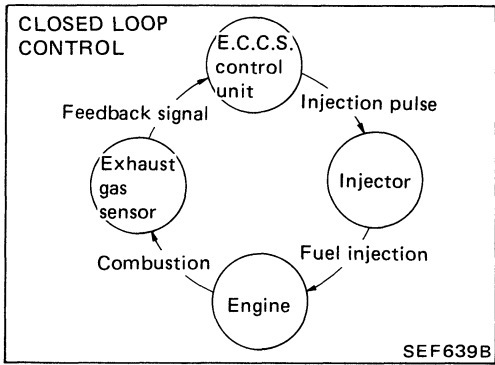

3) Mixture ratio feedback control (Closed loop control)

Mixture ratio feedback system is designed to control the mixture ratio precisely to the stoichiometric point so that the three way catalyst can minimize CO, HC and NOx emissions simultaneously. This system uses an exhaust gas sensor located in the exhaust manifold to give an indication of whether the air-fuel ratio is richer or leaner than the stoichiometric point. The E.C.U. adjusts the injection pulse width according to the sensor voltage so the mixture ratio will be within the narrow window around the stoichiometric air fuel ratio.

However, this system will operate under open loop under the following conditions:

- When starting engine.
- When engine temperature is cold.
- When exhaust gas sensor temperature is cold.
- When driving at high speeds or under heavy load.
- At idle.
- When the exhaust gas sensor monitors a rich condition for more than a few seconds.
- When A.I.V. control system is operated.

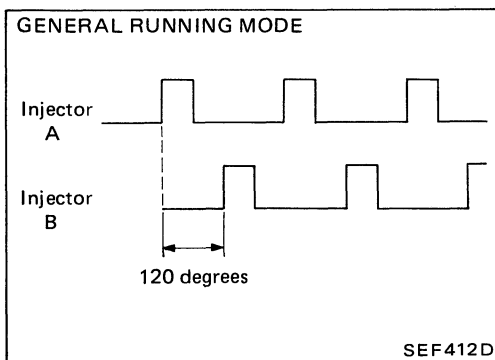

4) Fuel injection timing.

Fuel is injected alternately by two injectors during most operating conditions.

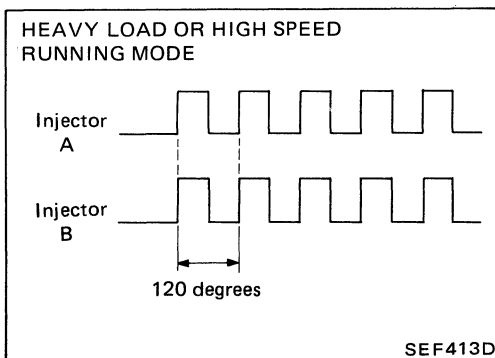

When accelerating, during heavy load or high speed conditions, fuel is injected simultaneously by both injectors.

Ignition Timing Control

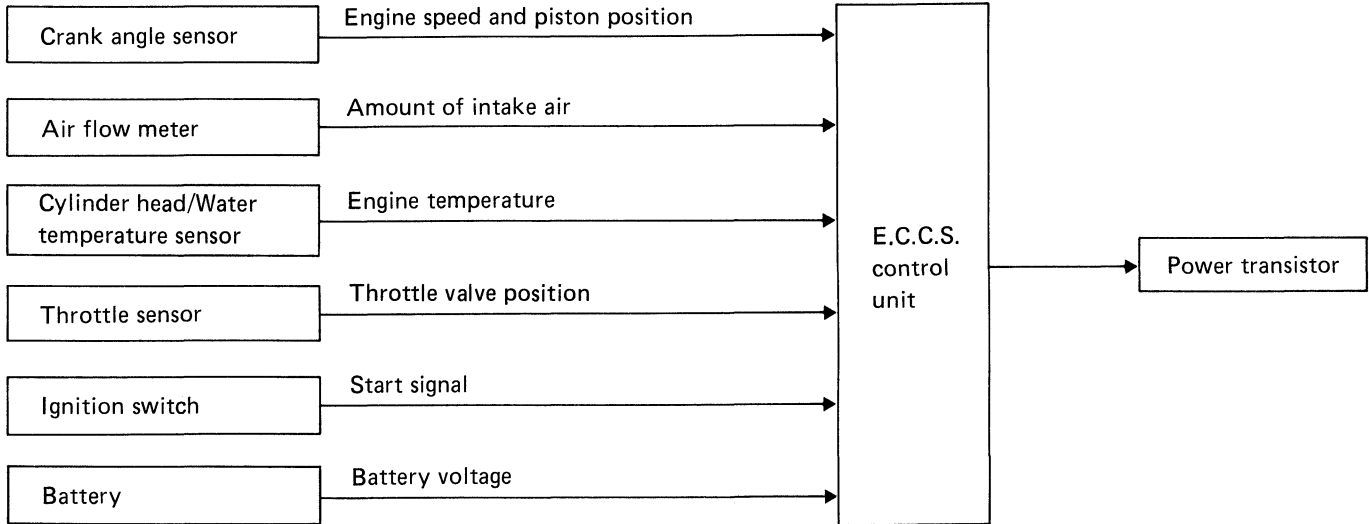

VG30i

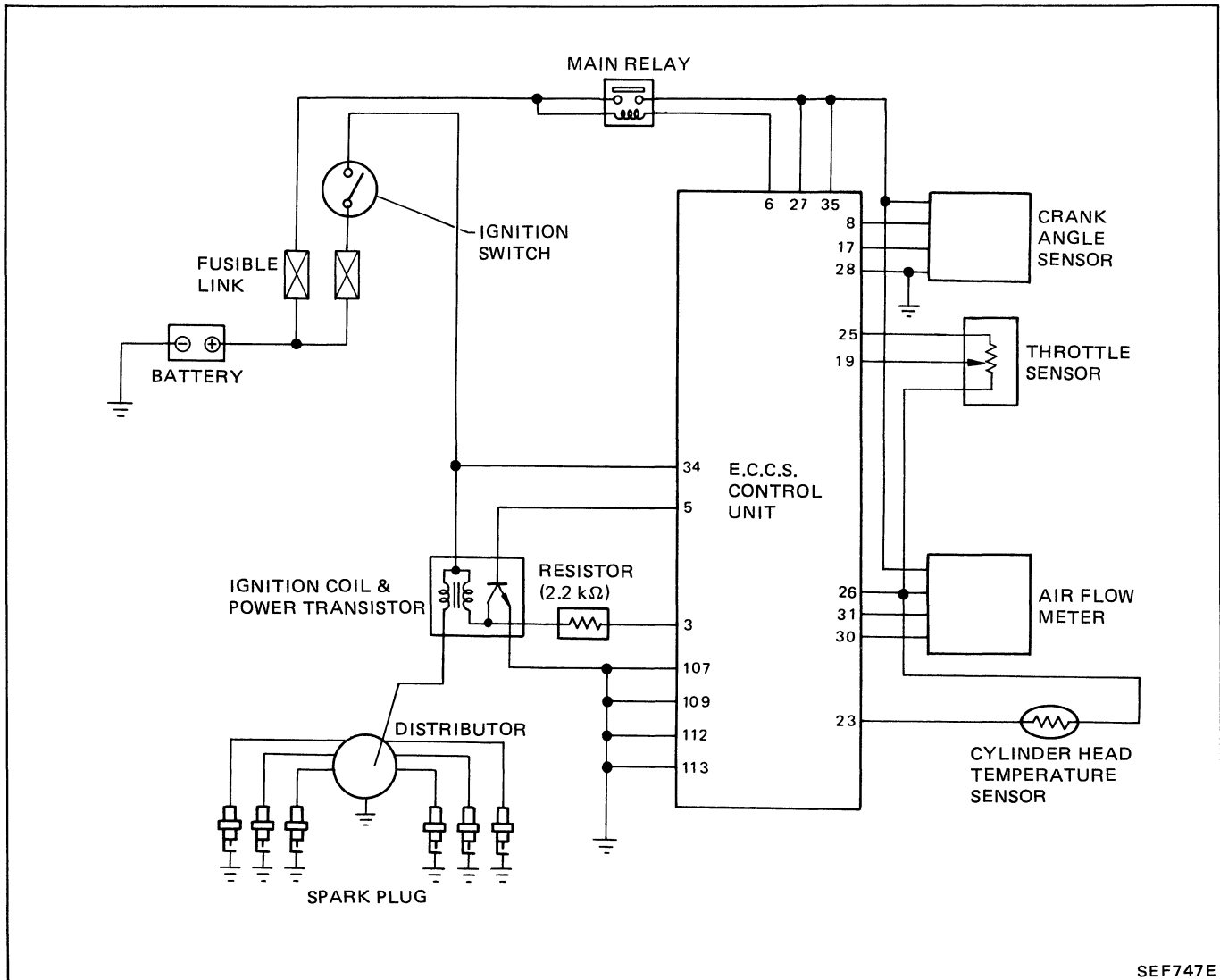

SEF747E

Ignition Timing Control (Cont'd)

Operation

Throttle valve position	Cylinder head temperature °C (°F)			Remarks
	Below 37 (99)	Between 37 (99) and 55 (131)	Above 55 (131)	
Idle	Advanced			
Off idle	Advanced	Normal*	Advanced	See CAUTION 1.
	Advanced			See CAUTION 2.

* "Normal" means the pre-programmed ignition timing data.

CAUTION 1:

Limited to the following conditions:

- 1 Engine speed is less than 3,200 rpm.
2. Cylinder head temperature at starting is above 10°C (50°F).

CAUTION 2:

Except the conditions shown above.

Z24i

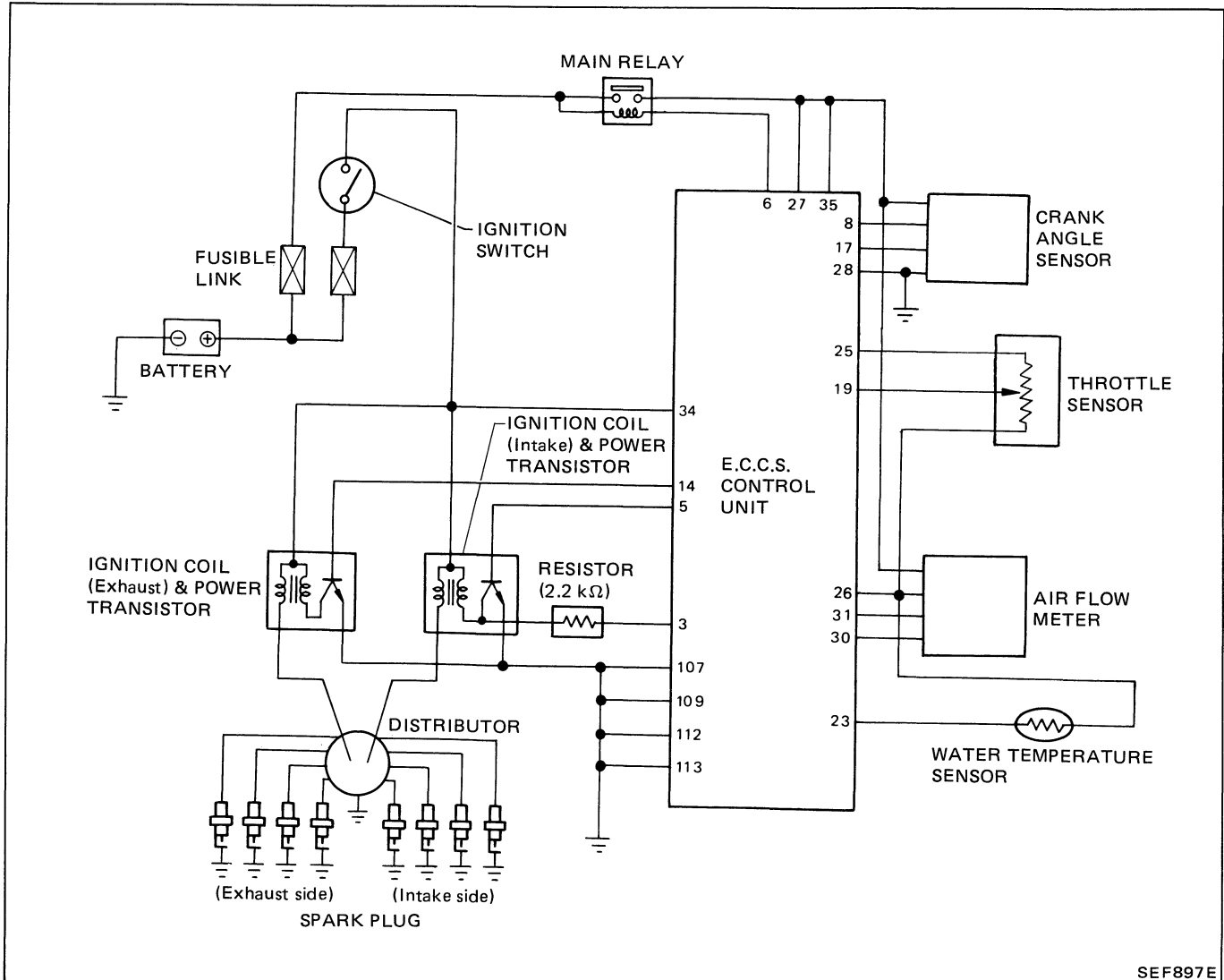

SEF897E

Ignition Timing Control (Cont'd)

Operation

Throttle valve position	Water temperature when starting °C (°F)	Water temperature °C (°F)		
		Below 15 (59)	Between 15 (59) and 70 (158)	Above 70 (158)
Idle	Below 15 (59)	Normal*	Advanced	Normal*
	Above 15 (59)		Advanced	
Off idle	Below 15 (59)	Advanced	Advanced	Normal*
	Above 15 (59)		1) When engine speed is between 800 rpm and 2,500 rpm in light load condition Retard 2) Except above Normal*	

*"Normal" means the pre-programmed ignition timing data.

F.I.C.D. Control

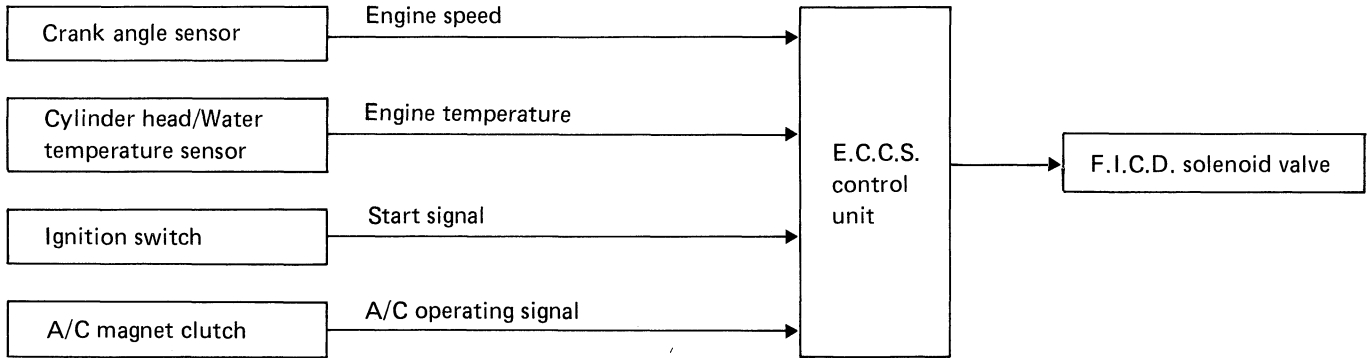

Operation

Conditions	F.I.C.D. solenoid operation
① When starting engine [Z24i]	ON
② For a few seconds after starting engine [Z24i]	
③ Air conditioner "ON"	
Except above	OFF

Fuel Pump Control

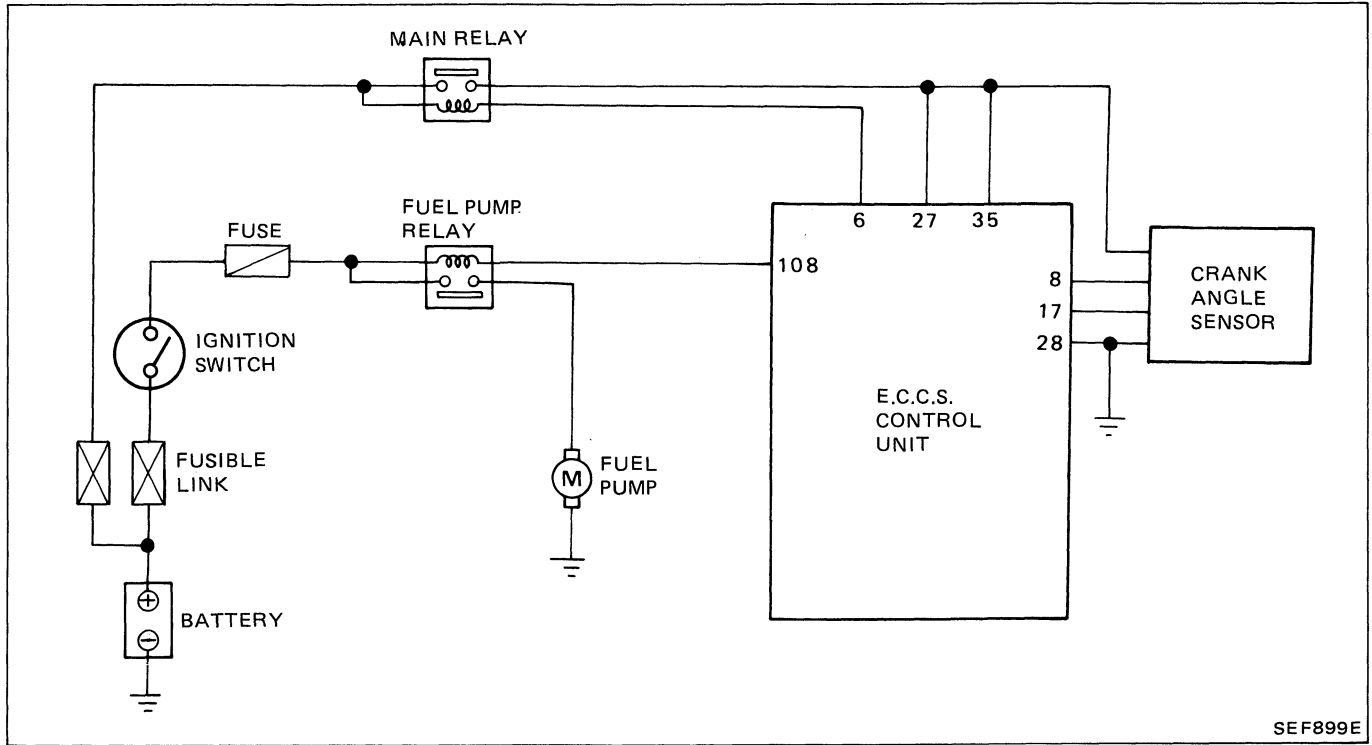
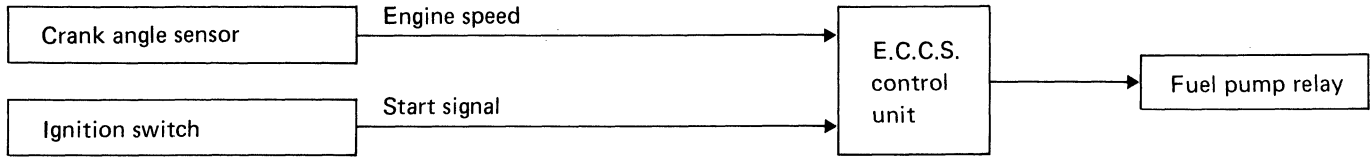

Fuel pump ON-OFF control

Ignition switch position	Engine condition	Fuel pump relay	Fuel pump operation
ON	Stopped	ON → OFF	Operates for a few seconds after ignition switch turns to "ON"
	Starting	ON	Operates
	Running	ON	Operates
	After stall	OFF	Stops in 1 second

Mixture Heating Control

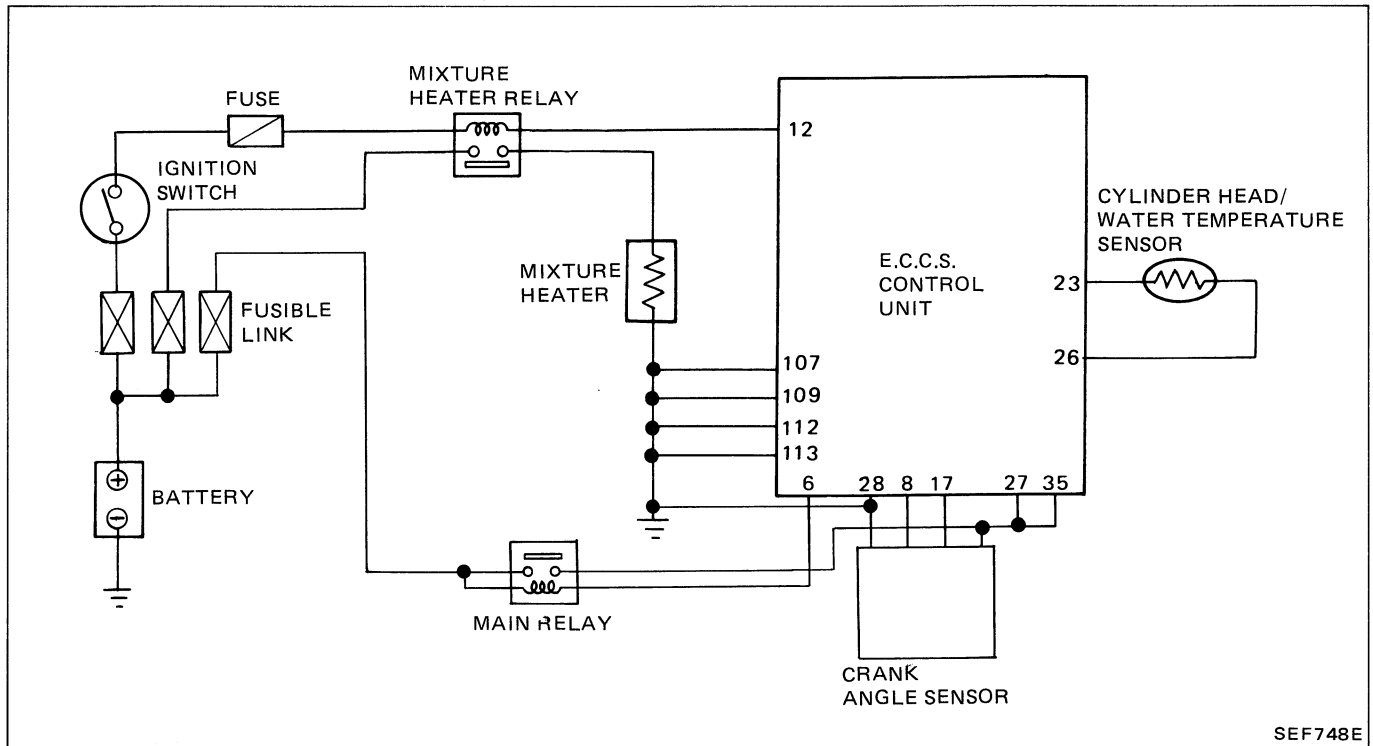
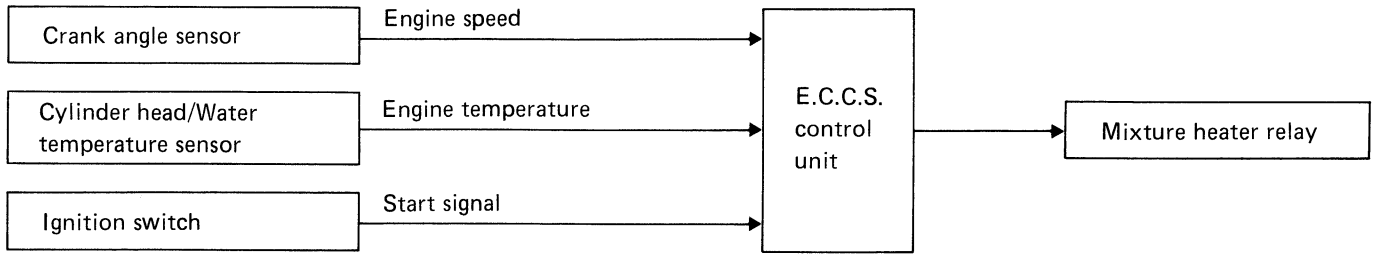

SEF748E

Mixture heater relay ON – OFF control

Ignition switch position	Engine condition	Cylinder head/Water temperature °C (°F)	Mixture heater relay	Mixture heater
OFF	Stopped	Any temperature	OFF	Does not operate
START	Cranking	Below 70 (158)	ON	Operates
		Above 70 (158)	OFF	Does not operate
ON	Stopped or after stall	Any temperature	OFF	Does not operate
	Running under light-load condition	Below 70 (158)	ON	Operates
		Above 70 (158)	OFF	Does not operate
	Running under heavy-load condition for a few min. or more	Below 70 (158)	ON	Operates
Above 70 (158)		ON for a few min.	Operates for a few min.	

**A.I.V. (Air Induction Valve) Control
[VG30i, Z24i (2WD)]**

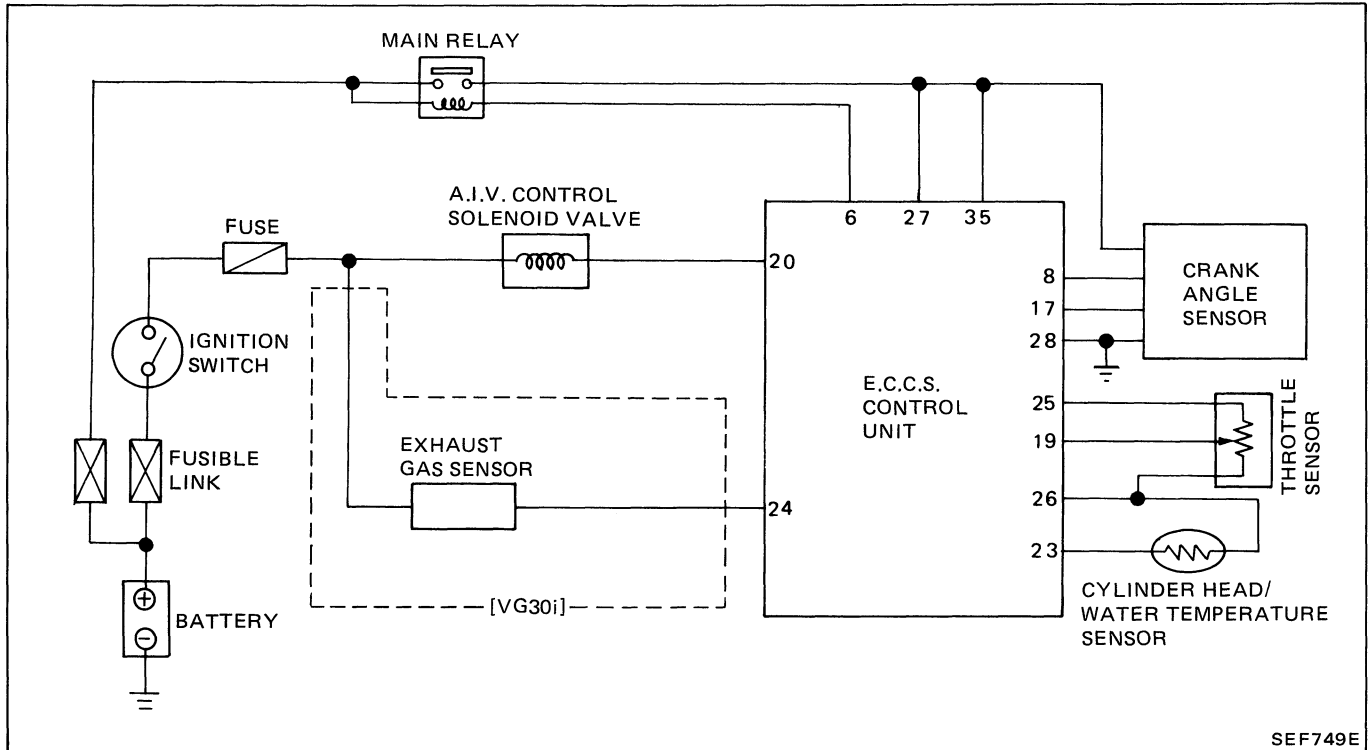
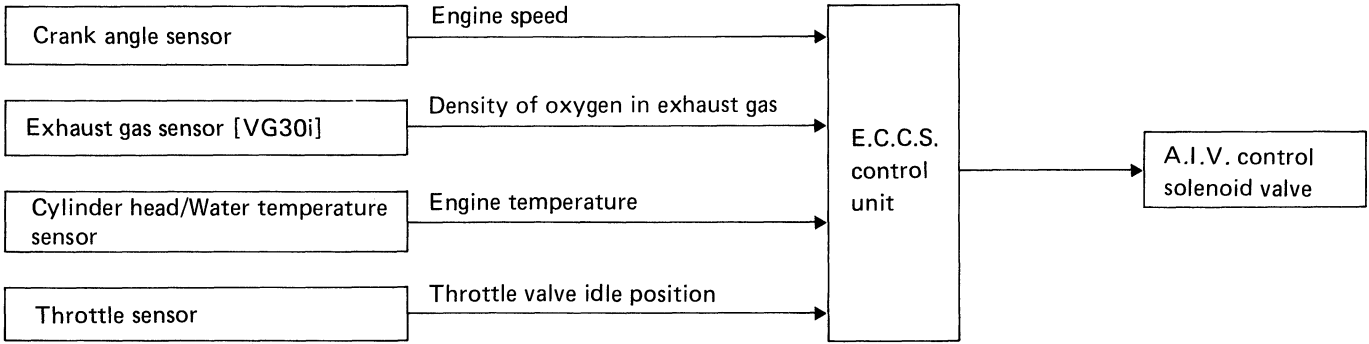

SEF749E

OPERATION (COLD A.I.V. CONTROL SYSTEM)

Cylinder head/Water temperature °C (°F)		Driving condition	Throttle valve position	A.I.V. control solenoid valve	A.I.V. control system
VG30i	Z24i (2WD)				
Below 15 (59)	Below 10 (50)	ANY	ANY	OFF	Does not operate
Between 15 (59) and 40 (104)	Between 10 (50) and 50 (122)			ON	Operates
Above 40 (104)	Above 50 (122)	Deceleration	Idle	ON	Operates for a few min.
			Off idle	OFF	Does not operate

Hot A.I.V. control system always operates.

E.G.R. (Exhaust Gas Recirculation) Control

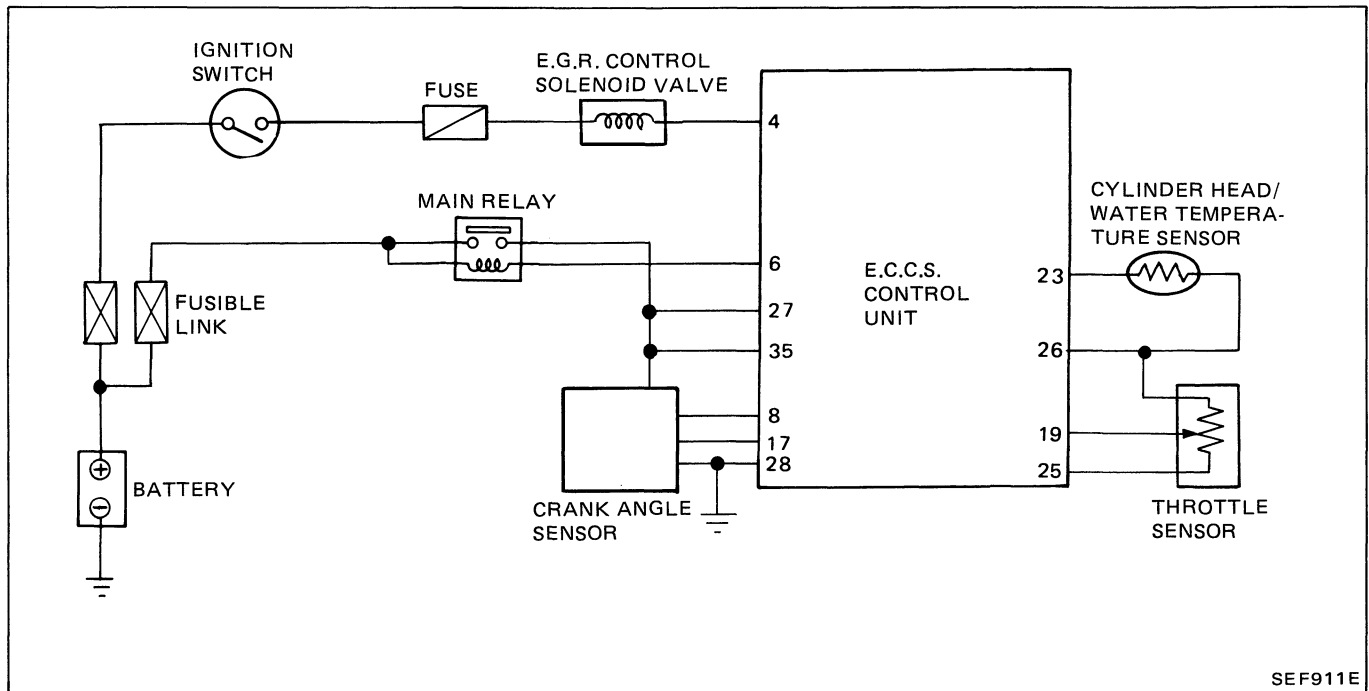
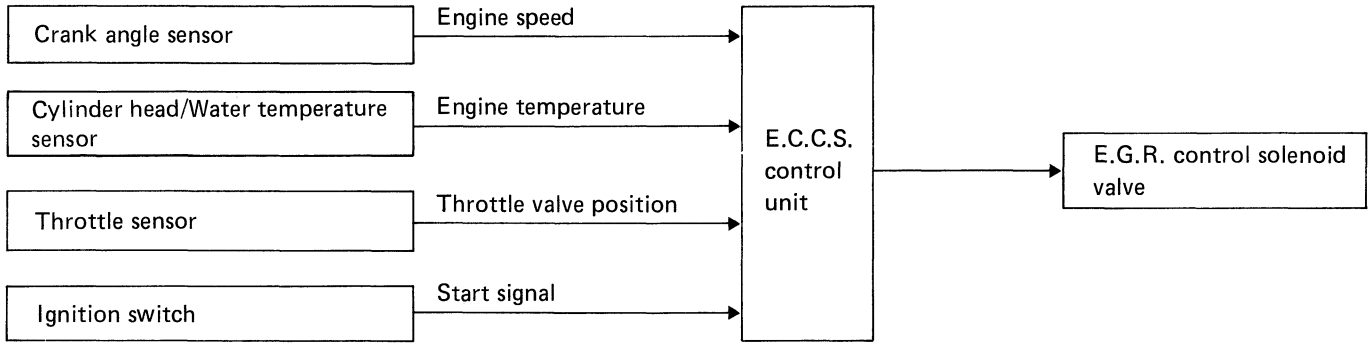

SEF911E

Operation

Conditions	E.G.R. control solenoid	E.G.R. system
① When starting engine ② Low engine temperature ③ When idling ④ High engine speed <ul style="list-style-type: none"> • More than 3,200 rpm [VG30i] • More than 4,500 rpm [Z24i] 	ON	Does not operate
⑤ Low engine speed <ul style="list-style-type: none"> • Less than 900 rpm [VG30i] • Less than 1,000 rpm [Z24i] 		
Except above	OFF	Operates

Idle-up Control

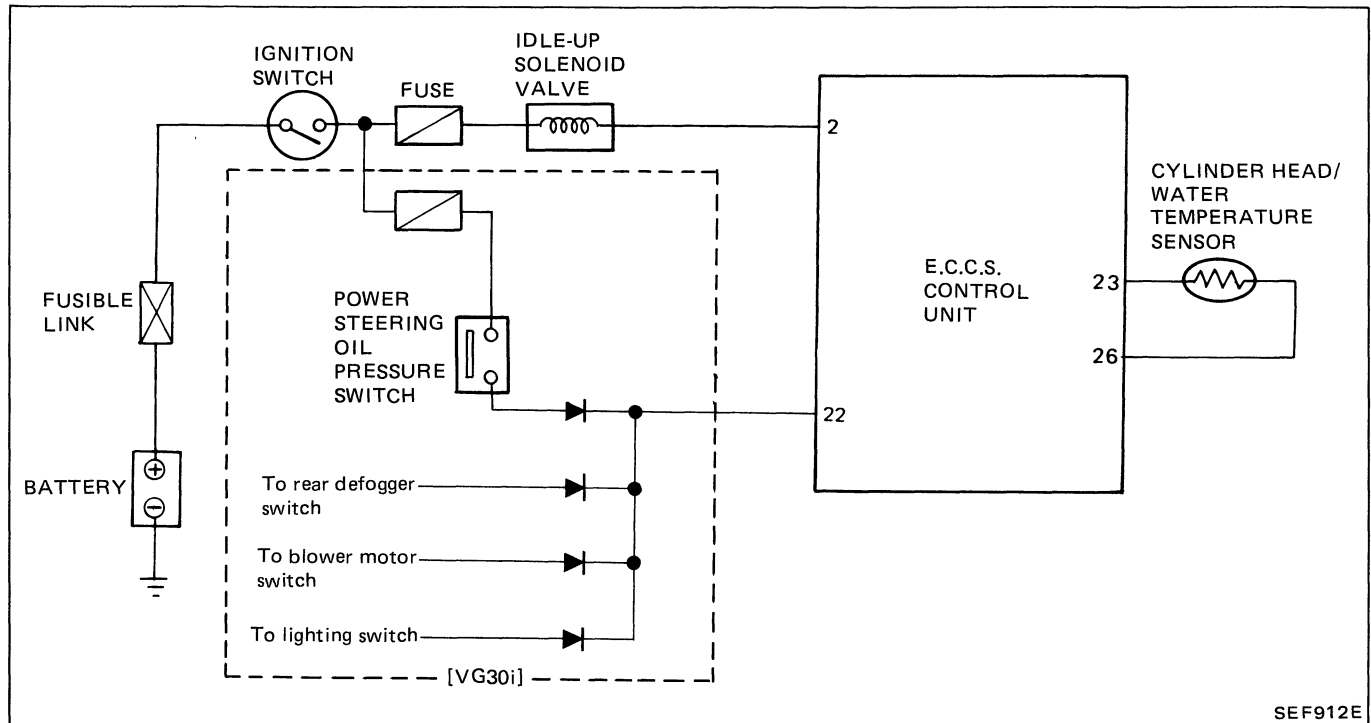
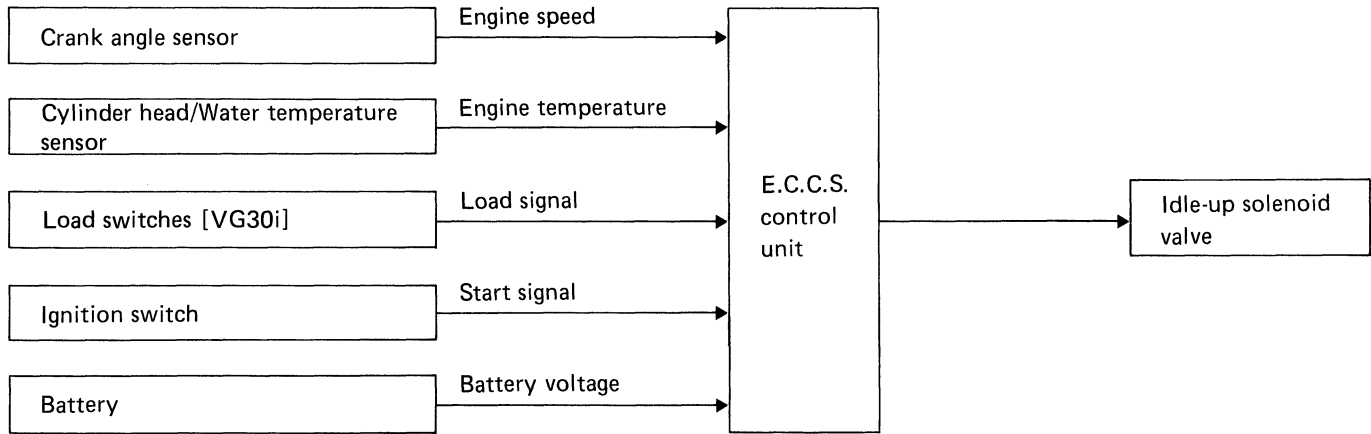

SEF912E

Operation

Conditions	Idle-up solenoid operation
① When starting engine ② For a few seconds after starting engine. ③ For a few minutes after starting engine if battery voltage is { below 12V. [VG30i] { below 10V. [Z24i] ④ Power steering oil pressure switch "ON" ⑤ Load switches "ON" [VG30i] — Lighting switch "ON" — Blower motor switch "ON" — Rear defogger switch "ON"	ON
Except above	OFF

Spark Plug Switching Control

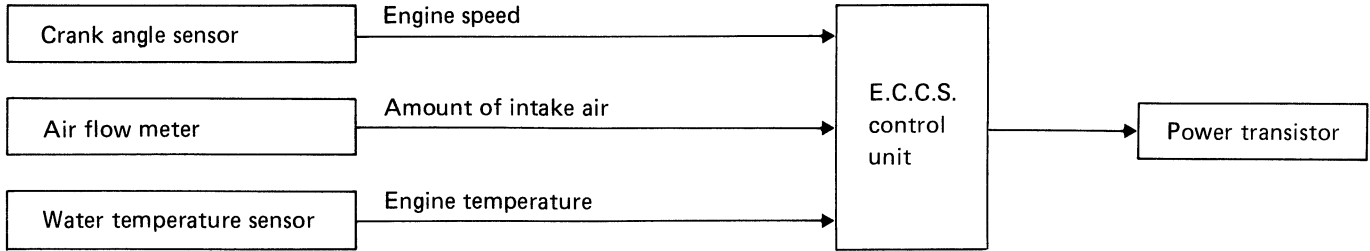

The spark plug switching control system is designed to change the ignition system from 2-plug

ignition to 1-plug ignition during heavy load driving in order to reduce engine noise.

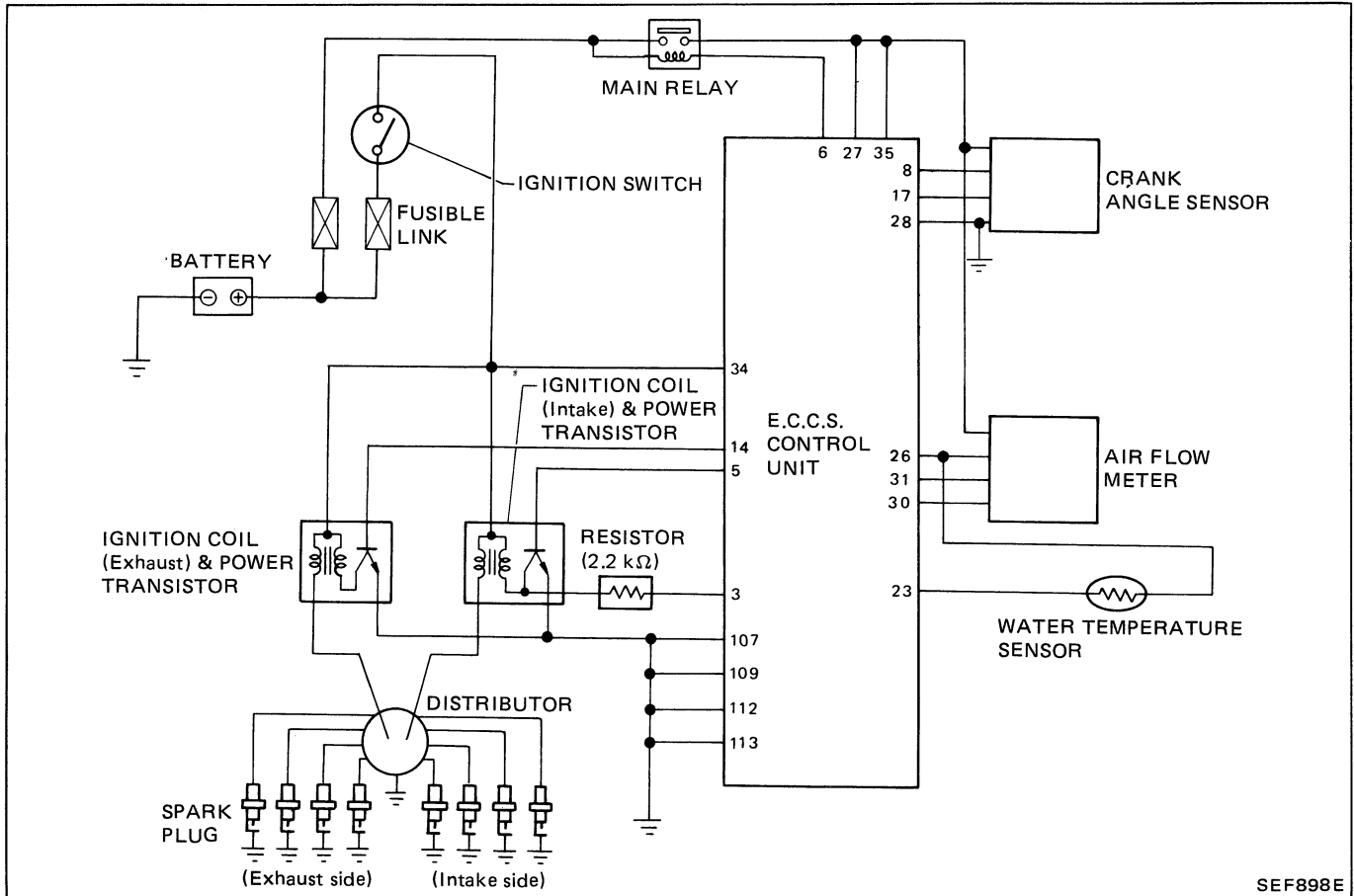

SEF898E

Operation

Water temperature °C (°F)	Engine operation condition	Engine speed rpm	Spark control
Below 70 (158)	Heavy load	Above 2,500	1-spark plug system
		Below 2,500	2-spark plug system
	Light load	Any	2-spark plug system
Above 70 (158)	Heavy load	Above 2,400	1-spark plug system
		Below 2,400	2-spark plug system
	Light load	Any	2-spark plug system

Fail-safe System Description

1. Air flow meter malfunctioning
 If the air flow meter output voltage is lower or higher than the specified value, E.C.U. senses an air flow meter malfunctioning. In case air flow meter malfunctions, the throttle sensor substitutes for the air flow meter.
- Through air flow meter is malfunctioning, it is possible to drive the vehicle and start the engine. But engine speed will not rise more than 2,800 rpm in order to inform the driver of fail-safe system operation while driving.

Operation

Engine condition	Starter switch	Fail-safe system	Fail-safe functioning
Stopped	ANY	Does not operate	—
Cranking	ON	Operates	Engine will be started by a pre-determined injection pulse on E.C.U.
Running	OFF		Engine speed will not rise above 2,800 rpm

2. Injector malfunctioning (VG30i model only)
 When engine speed is less than 2,000 rpm in the alternating injection mode (except during acceleration), and injection pulse angle is less than 79 degrees (Crank angle), if at least one injector does not inject fuel four times successively because of the electric problem,
- E.C.U. senses injector malfunctioning. If one injector malfunctions, it is possible to drive the vehicle and start the engine. But engine speed will not rise above 2,800 rpm in order to inform the driver of fail-safe system operation while driving.

Operation

Engine condition that senses injection malfunctioning	Number of failed injectors	Injector pulse duration	Fail-safe functioning
Less than 2,000 rpm (Except during acceleration)	1	1) In alternative injection Normal duration with another remaining injector every 120 degrees. 2) In simultaneous injection Twice the duration with the other remaining injector.	Engine speed will not rise above 2,800 rpm.
	2	Zero	Fuel is shut off.

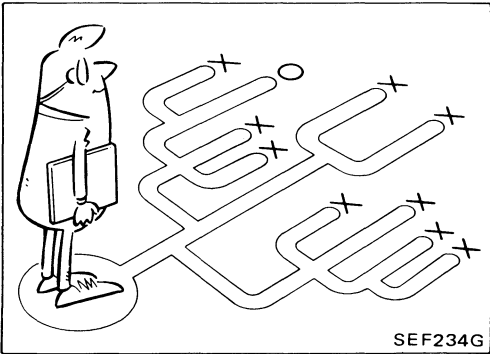
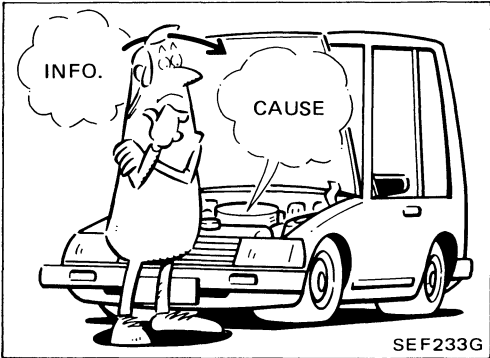
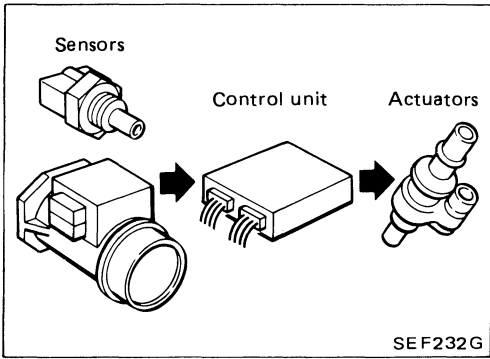

Introduction

The engine has an electronic control unit to control major systems such as fuel control, ignition control, idle speed control, etc. The control unit accepts input signals from sensors and instantly drives actuators. It is essential that both kinds of signals are proper and stable. At the same time, it is important that there are no conventional problems such as vacuum leaks, fouled spark plugs, or other problems with the engine.

It is much more difficult to diagnose a problem that occurs intermittently rather than continuously. Most intermittent problems are caused by poor electric connections or faulty wiring. In this case, careful checking of suspicious circuits may help prevent the replacement of good parts.

A visual check only may not find the cause of the problems. A road test with a circuit tester connected to a suspected circuit should be performed.

Before undertaking actual checks, take just a few minutes to talk with a customer who approaches with a driveability complaint. The customer is a very good supplier of information on such problems, especially intermittent ones. Through the talks with the customer, find out what symptoms are present and under what conditions they occur.

Start your diagnosis by looking for "conventional" problems first. This is one of the best ways to troubleshoot driveability problems on an electronically controlled engine vehicle.

Work Flow

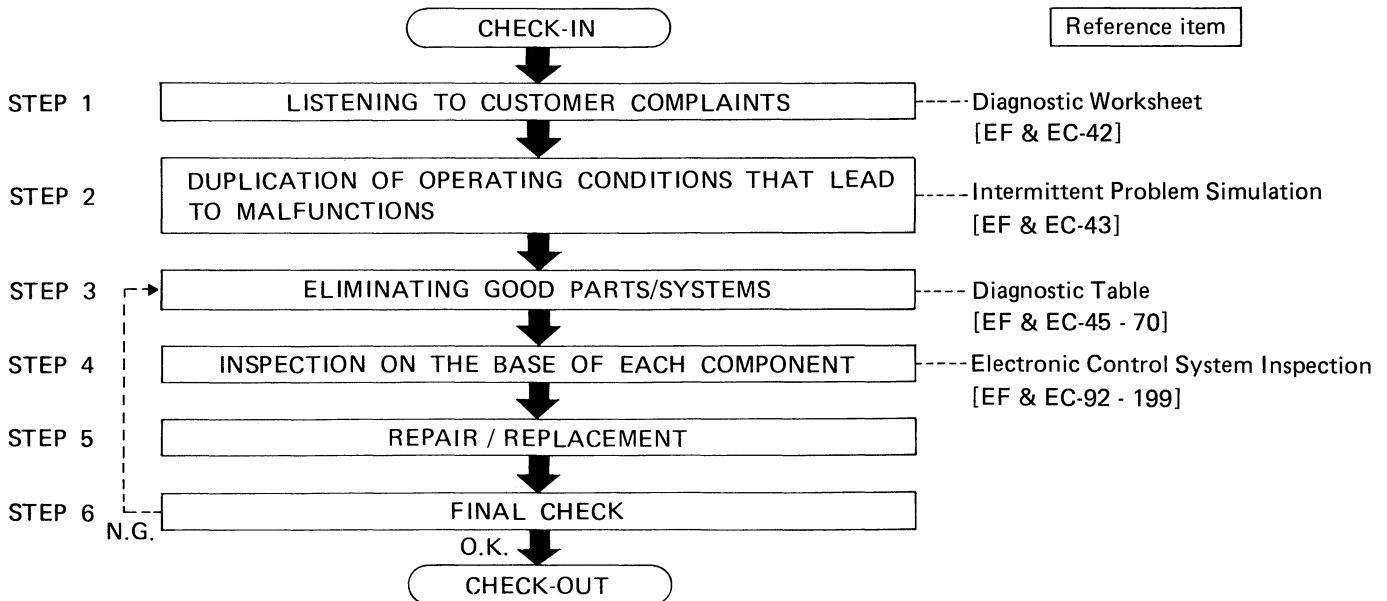

KEY POINTS

WHAT Vehicle & engine model
WHEN Date, Frequencies
WHERE Road conditions
HOW Operating conditions,
Weather conditions,
Symptoms

Diagnostic Worksheet

There are many kinds of operating conditions that lead to malfunctions on engine components.

A good grasp of such conditions can make troubleshooting faster and more accurate.

In general, feelings for a problem depend on each customer. It is important to fully understand the symptoms or under what conditions a customer complains.

Make good use of a diagnostic worksheet such as the one shown below in order to utilize all the complaints for troubleshooting.

WORKSHEET SAMPLE

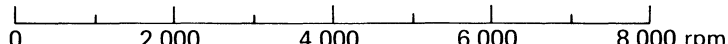
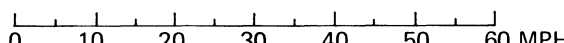
Customer name MR/MS		Model & Year	VIN
Engine #		Trans.	Mileage
Incident Date		Manuf. Date	In Service Date
Symptoms	<input type="checkbox"/> Startability	<input type="checkbox"/> Impossible to start <input type="checkbox"/> No combustion <input type="checkbox"/> Partial combustion <input type="checkbox"/> Partial combustion affected by throttle position <input type="checkbox"/> Partial combustion NOT affected by throttle position <input type="checkbox"/> Possible but hard to start <input type="checkbox"/> Others []	
	<input type="checkbox"/> Idling	<input type="checkbox"/> No fast idle <input type="checkbox"/> Unstable <input type="checkbox"/> High idle <input type="checkbox"/> Low idle <input type="checkbox"/> Others []	
	<input type="checkbox"/> Driveability	<input type="checkbox"/> Stumble <input type="checkbox"/> Surge <input type="checkbox"/> Detonation <input type="checkbox"/> Lack of power <input type="checkbox"/> Intake backfire <input type="checkbox"/> Exhaust backfire <input type="checkbox"/> Others []	
	<input type="checkbox"/> Engine stall	<input type="checkbox"/> At the time of start <input type="checkbox"/> While idling <input type="checkbox"/> While accelerating <input type="checkbox"/> While decelerating <input type="checkbox"/> Just after stopping <input type="checkbox"/> While loading	
Incident occurrence		<input type="checkbox"/> Just after delivery <input type="checkbox"/> Recently <input type="checkbox"/> In the morning <input type="checkbox"/> At night <input type="checkbox"/> In the daytime	
Frequency		<input type="checkbox"/> All the time <input type="checkbox"/> Under certain conditions <input type="checkbox"/> Sometimes	
Weather conditions		<input type="checkbox"/> Not effected	
Weather		<input type="checkbox"/> Fine <input type="checkbox"/> Raining <input type="checkbox"/> Snowing <input type="checkbox"/> Others []	
Temperature		<input type="checkbox"/> Hot <input type="checkbox"/> Warm <input type="checkbox"/> Cool <input type="checkbox"/> Cold <input type="checkbox"/> Humid °F	
Engine conditions		<input type="checkbox"/> Cold <input type="checkbox"/> During warm-up <input type="checkbox"/> After warm-up Engine speed 	
Road conditions		<input type="checkbox"/> In town <input type="checkbox"/> In suburbs <input type="checkbox"/> Highway <input type="checkbox"/> Off road (up/down)	
Driving conditions		<input type="checkbox"/> Not affected <input type="checkbox"/> At starting <input type="checkbox"/> While idling <input type="checkbox"/> At racing <input type="checkbox"/> While accelerating <input type="checkbox"/> While cruising <input type="checkbox"/> While decelerating <input type="checkbox"/> While turning (RH/LH) Vehicle speed 	
Check engine light		<input type="checkbox"/> Turned on <input type="checkbox"/> Not turned on	

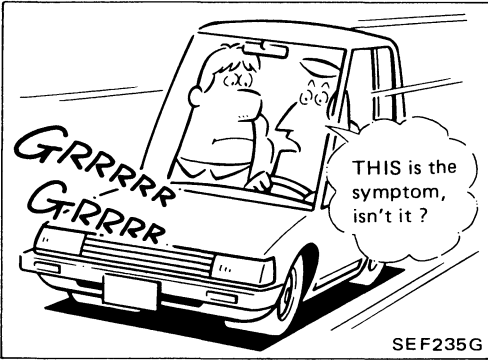

Intermittent Problem Simulation

In order to duplicate an intermittent problem, it is effective to create similar conditions for component parts, under which the problem might occur.

Perform the activity listed under Service procedure and note the result.

	Variable factor	Influential part	Target condition	Service procedure
1	Mixture ratio	Pressure regulator	Made lean	Remove vacuum hose and apply vacuum.
			Made rich	Remove vacuum hose and apply pressure.
2	Ignition timing	Distributor	Advanced	Rotate distributor clockwise.
			Retarded	Rotate distributor counterclockwise.
3	Mixture ratio feedback control	Exhaust gas sensor	Suspended	Disconnect exhaust gas sensor harness connector.
		Control unit	Operation check	Perform self-diagnosis (Mode I/II) at 2,000 rpm.
4	Idle speed	Throttle body	Raised	Turn idle adjust screw counterclockwise.
			Lowered	Turn idle adjust screw clockwise.
5	Electric connection (Electric continuity)	Harness connectors and wires	Poor electric connection or faulty wiring	Tap or wiggle.
				Race engine rapidly. See if the torque reaction of the engine unit causes electric breaks.
6	Temperature	Control unit	Cooled	Cool with an icing spray or similar device.
			Warmed	Heat with a hair drier. [WARNING: Do not overheat the unit.]
7	Moisture	Electric parts	Damp	Wet [WARNING: Do not directly pour water on components. Use a mist sprayer.]
8	Electric loads	Load switches	Loaded	Turn on head lights, air conditioner, rear defogger, etc.
9	Idle switch condition	Control unit	ON-OFF switching	Perform self-diagnosis (Mode IV).
10	Ignition spark	Timing light	Spark power check	Try to flash timing light for each cylinder.

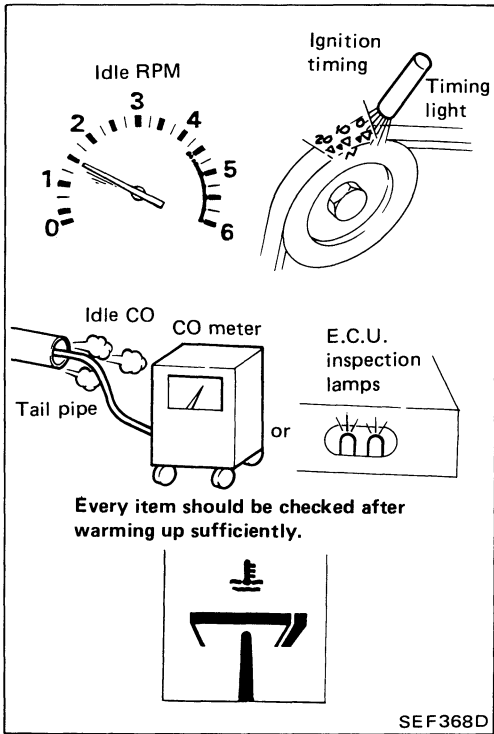

Specifications

1) Idle speed

VG30i:

M/T: 800±50 rpm

A/T: 700±50 rpm (in "D" position)

Z24i:

M/T: 800±50 rpm

A/T: 650±50 rpm (in "D" position)

2) Ignition timing

VG30i: 12°±2° B.T.D.C.

Z24i: 10°±2° B.T.D.C.

3) Idle CO

VG30i:

0.2 - 5.0% No A.I.V. controlled condition (in tail pipe) or flashes of E.C.U. red inspection lamp in Mode II (If flashes, O.K.).

Z24i:

1.0 - 7.0% No A.I.V. controlled condition (in tail pipe) or flashes of E.C.U. red inspection lamp in Mode II (If flashes, O.K.).

4) Mixture ratio at approximately 2,000 rpm of engine speed.

Number of flashes of E.C.U. inspection green lamp in Mode I:

VG30i: 5 times or more/10 seconds

Z24i: 7 times or more/10 seconds

5) Engine speed of idle switch OFF → ON speed

VG30i:

M/T: Idle speed + 250±150 rpm

A/T: Engine speed (Idle speed in "N" position) + 250±150 rpm

Z24i:

1,600⁺⁵⁵⁰₋₂₅₀ rpm (A/T: in "N" position)

Diagnostic Table

To assist with your troubleshooting, some typical diagnostic procedures for the following symptoms are described.

CONTENTS

1. Impossible to start	– no combustion	EF & EC-46
2. Impossible to start	– partial combustion	EF & EC-47
3. Impossible to start	– partial combustion (not affected by throttle position)	EF & EC-48
4. Impossible to start	– partial combustion (throttle position changes combustion quality)	EF & EC-49
5. Hard to start	– before warm-up	EF & EC-50
6. Hard to start	– after warm-up	EF & EC-51
7. Hard to start	– every time	EF & EC-52
8. Hard to start	– morning after a rainy day	EF & EC-53
9. Abnormal idling	– no fast idle	EF & EC-54
10. Abnormal idling	– low idle (after warm-up)	EF & EC-55
11. Abnormal idling	– high idle (after warm-up)	EF & EC-56
12. Unstable idling	– before warm-up	EF & EC-57
13. Unstable idling	– after warm-up	EF & EC-58
14. Poor driveability	– stumble (while accelerating)	EF & EC-59
15. Poor driveability	– surge (while cruising)	EF & EC-60
16. Poor driveability	– lack of power	EF & EC-61
17. Poor driveability	– detonation	EF & EC-62
18. Engine stall	– during start-up	EF & EC-63
19. Engine stall	– while idling	EF & EC-64
20. Engine stall	– while accelerating	EF & EC-65
21. Engine stall	– while cruising	EF & EC-66
22. Engine stall	– while decelerating/just after stopping	EF & EC-67
23. Engine stall	– while loading (power steering, air conditioner, headlamps, etc.)	EF & EC-68
24. Backfire	– through the intake	EF & EC-69
25. Backfire	– through the exhaust	EF & EC-70

REMARKS

In the following pages, the numbers such as ❶, ❷ in the above chart correspond to those in the service procedure described below.
Possible causes can be checked through the service procedure shown by the mark “○”.

Diagnostic Table (Cont'd)

SYMPTOM & CONDITION 1 Impossible to start – no combustion

POSSIBLE CAUSES		1	2	3	4	5	6	7	8
SPECIFICATIONS	Mixture ratio (too lean)	○	○						
	Ignition sparks (weak, missing)				○	○	○		
	Ignition timing							○	
FUEL SYSTEM	Fuel pump (no operation)	○							
	Fuel pump relay (open circuited)	○							
	Injectors (no operation, clogged)		○						
IGNITION SYSTEM	Ignition switch	○	○	○	○			○	
	Main relay	○	○	○	○			○	
	Power transistor			○	○			○	
	Ignition coil				○			○	
	Center cable (ignition leaks)				○			○	
	Ignition wires (ignition leaks)				○	○			
	Spark plugs						○		
CONTROL SYSTEM	Crank angle sensor	○	○		○			○	○

SERVICE PROCEDURE

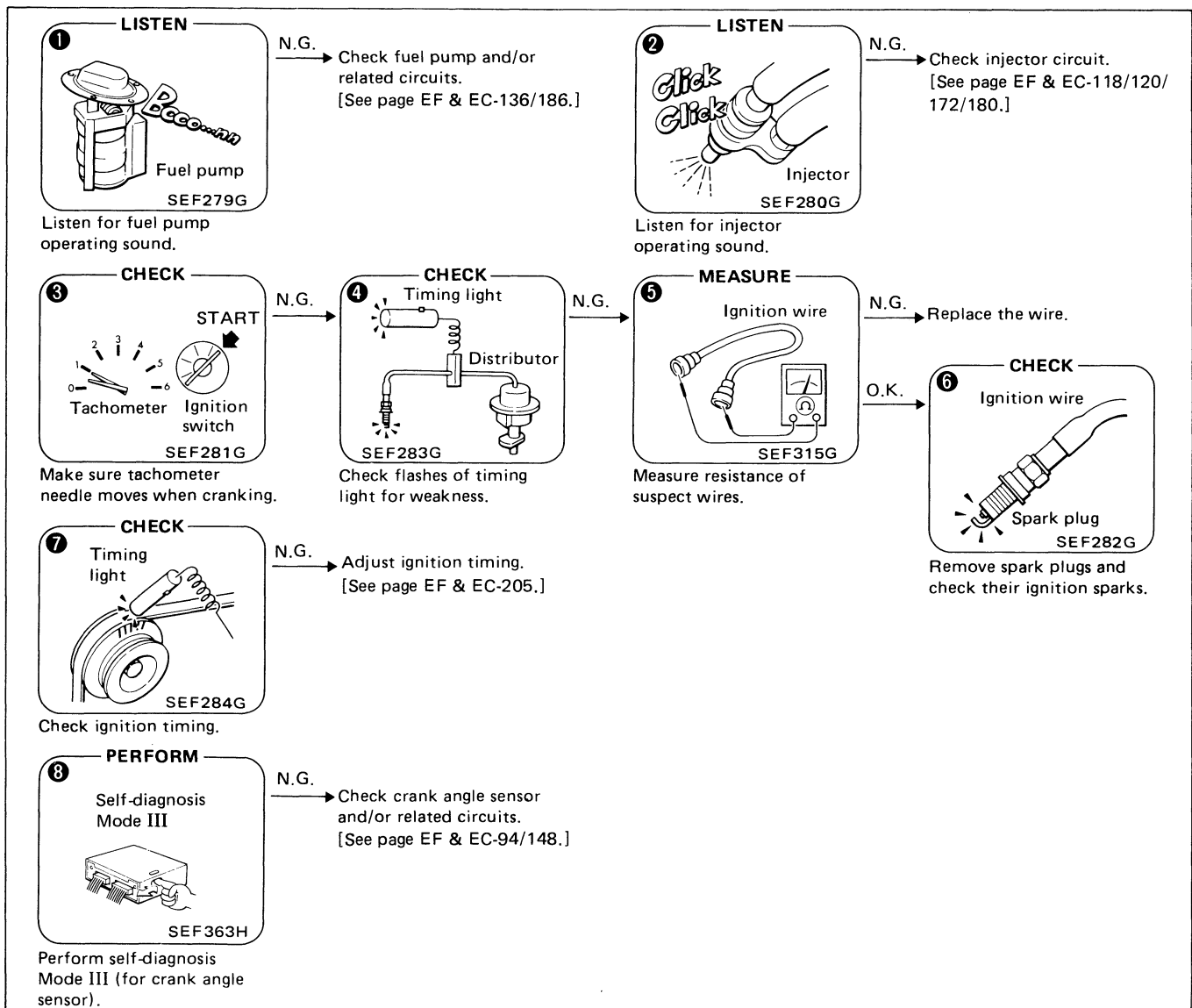

Diagnostic Table (Cont'd)

SYMPTOM & CONDITION **2** Impossible to start – partial combustion

POSSIBLE CAUSES		1	2	3	4	5
SPECIFICATIONS	Mixture ratio	○	○	○		
	Fuel pressure (too low)				○	
	Ignition timing					○
FUEL SYSTEM	Fuel pump	○				
	Fuel pump relay (open circuited)	○				
	Injectors (clogged)		○			

SERVICE PROCEDURE

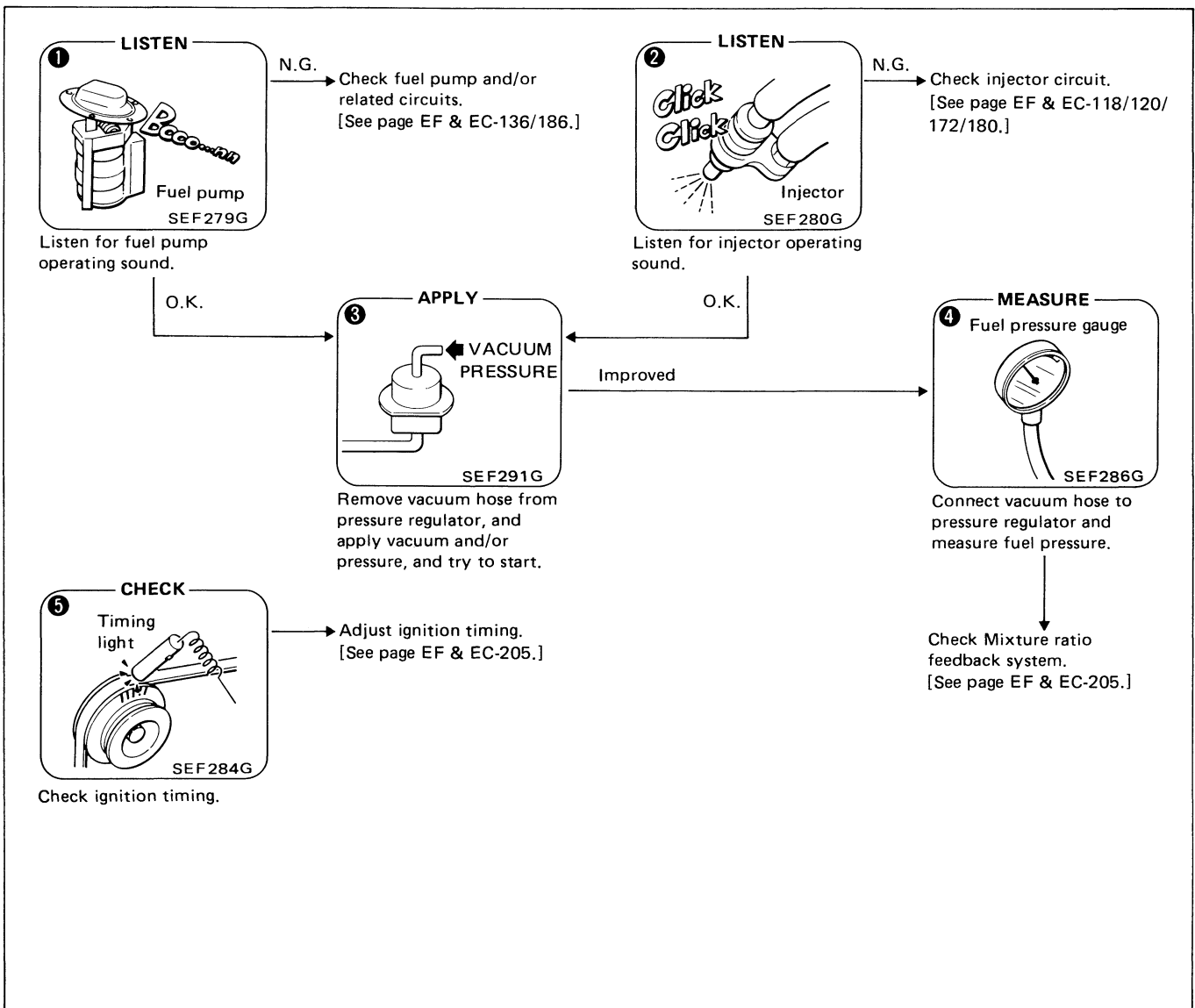

Diagnostic Table (Cont'd)

SYMPTOM & CONDITION 3 Impossible to start – partial combustion (not affected by throttle position)

POSSIBLE CAUSES		1	2	3	4	5	6	7	8	9	10	11	12
SPECIFICATIONS	Mixture ratio	○	○	○									
	Fuel pressure (too low)		○	○	○								
	Ignition timing					○							
FUEL SYSTEM	Fuel filter (clogged)				○								
	Fuel line (clogged)				○								
	Injectors (clogged)	○											
	Pressure regulator		○										
	Pressure regulator vacuum hose (clogged)		○										
IGNITION SYSTEM	Ignition wires (ignition leaks)					○	○						
	Spark plugs (wet with fuel)							○					
	Ignition switch	○				○				○			
INTAKE SYSTEM	Throttle body (with ports clogged)								○				
	Throttle valve (clogged)								○				
CONTROL SYSTEM	Cylinder head/Water-temperature sensor										○	○	
	Crank angle sensor	○				○					○		

SERVICE PROCEDURE

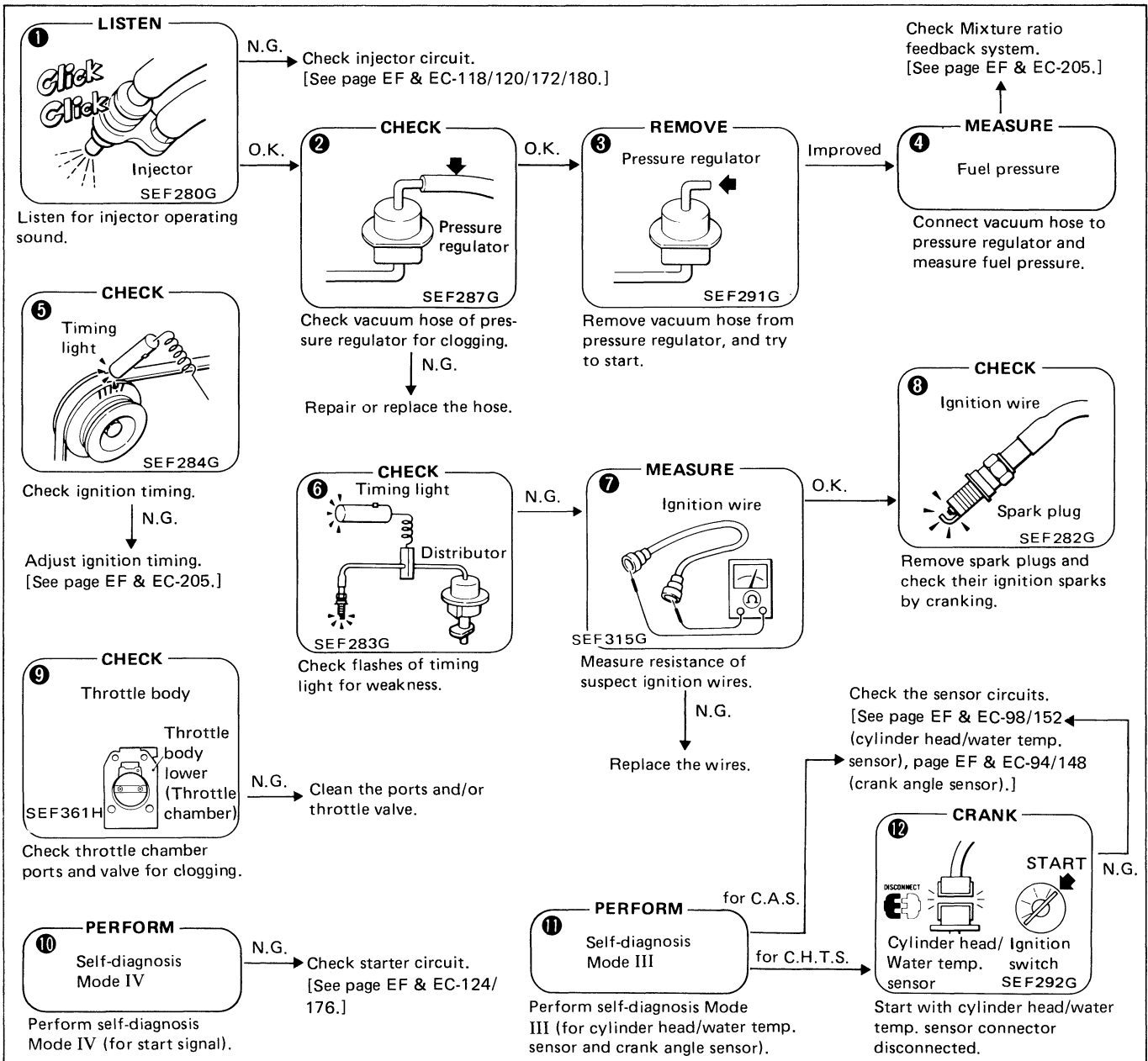

Diagnostic Table (Cont'd)

SYMPTOM & CONDITION 4 Impossible to start – partial combustion (throttle position changes combustion quality)

POSSIBLE CAUSES		1	2	3	4
INTAKE SYSTEM	Throttle body (with ports clogged)	○			
	Throttle valve (clogged)				○
	Fast idle cam		○		
	Idle speed control valve			○	
CONTROL SYSTEM	Cylinder head/Water temperature sensor			○	
	Idle switch			○	
	Neutral switch			○	

SERVICE PROCEDURE

1 CHECK

Throttle body

N.G. → Clean the ports.

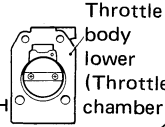

Throttle body lower (Throttle chamber)
SEF361H

Check throttle chamber ports for clogging.

2 CHECK

N.G. → Check fast idle cam. [See page EF & EC-214.]

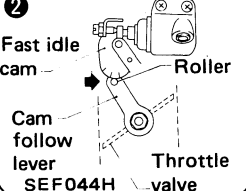

Fast idle cam
Roller
Cam follow lever
Throttle valve
SEF044H

Make sure throttle valve stays open by fast idle cam before warm-up.

3 CHECK

N.G. → Check idle speed control circuit. [See page EF & EC-146/196.]

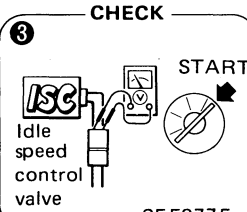

START

Idle speed control valve
SEF977F

Check terminal voltage of idle speed control valve while cranking.

4 CHECK

N.G. → Clean the valve.

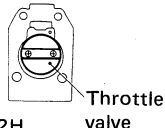

Throttle valve
SEF362H

Check throttle valve for clogging.

Diagnostic Table (Cont'd)

SYMPTOM & CONDITION 5 Hard to start – before warm-up

POSSIBLE CAUSES		1	2	3	4	5	6
SPECIFICATIONS	Mixture ratio			○			○
IGNITION SYSTEM	Ignition switch (no start signal)	○			○		
INTAKE SYSTEM	Fast idle cam			○			
CONTROL SYSTEM	Cylinder head/Water temperature sensor					○	○
	Idle switch				○		
	Neutral switch	○					
OTHERS	Starter (operation too slow)	○					
	Battery (voltage too low)	○	○				

SERVICE PROCEDURE

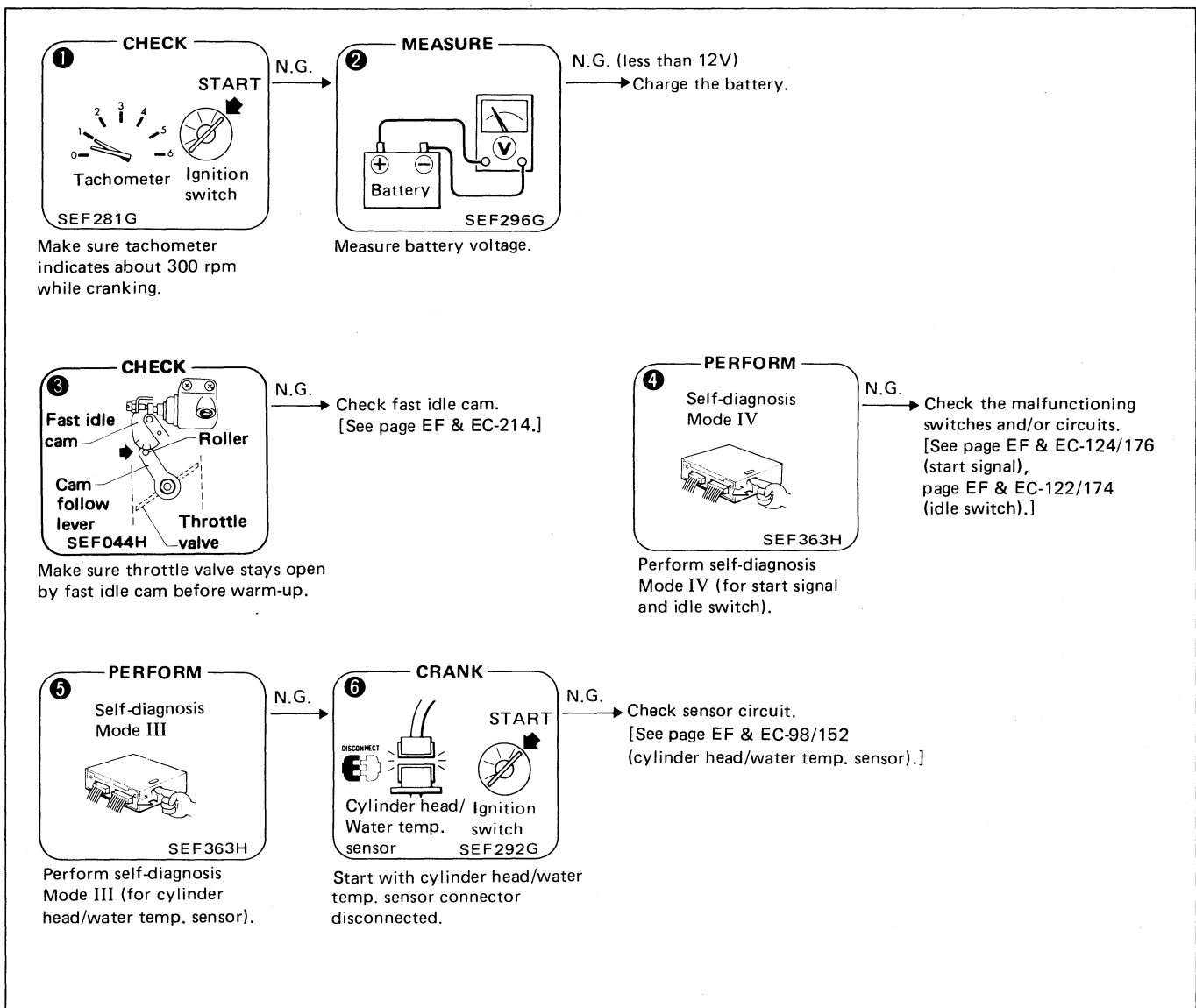

Diagnostic Table (Cont'd)

SYMPTOM & CONDITION 6 Hard to start – after warm-up

POSSIBLE CAUSES		1	2	3	4	5	6
SPECIFICATIONS	Mixture ratio			○			○
	Fuel pressure			○			○
FUEL SYSTEM	Fuel line (hot fuel)			○			
	Pressure regulator (low fuel pressure)						○
	Pressure regulator vacuum hose (clogged)						○
IGNITION SYSTEM	Ignition switch (no start signal)	○				○	
CONTROL SYSTEM	Cylinder head/Water temperature sensor				○		
	Air flow meter				○		
OTHERS	Starter (operation too slow)	○					
	Battery (voltage too low)	○	○				

SERVICE PROCEDURE

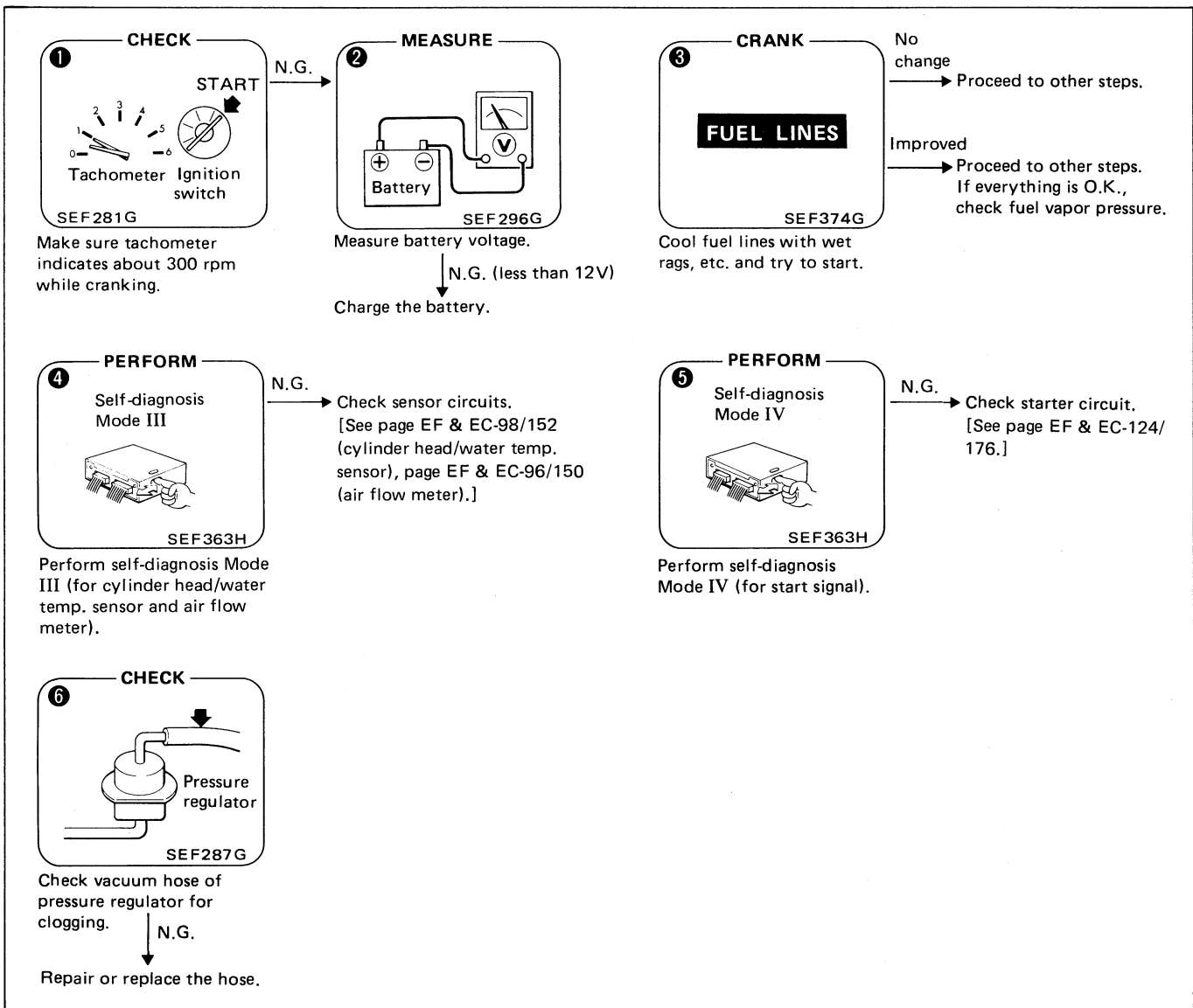

Diagnostic Table (Cont'd)

SYMPTOM & CONDITION 7 Hard to start – every time

POSSIBLE CAUSES		1	2	3	4	5	6	7	8	9	10	11	12
SPECIFICATIONS	Mixture ratio	○				○	○						
	Fuel pressure						○	○					
	Ignition sparks (missing)								○	○		○	
	Ignition timing				○								
FUEL SYSTEM	Fuel pump (improper operation)	○											
	Fuel line (clogged)							○					
	Canister (air leaks)					○							
	Pressure regulator (low fuel pressure)						○						
IGNITION SYSTEM	Ignition wires (ignition leaks)								○	○			
	Spark plugs (improper gap)										○		
CONTROL SYSTEM	Crank angle sensor	○							○				○
	Cylinder head/Water temperature sensor												○
	Idle switch												○
	Neutral switch		○										
OTHERS	Starter (operation too slow)		○										
	Battery (voltage too low)		○	○									

SERVICE PROCEDURE

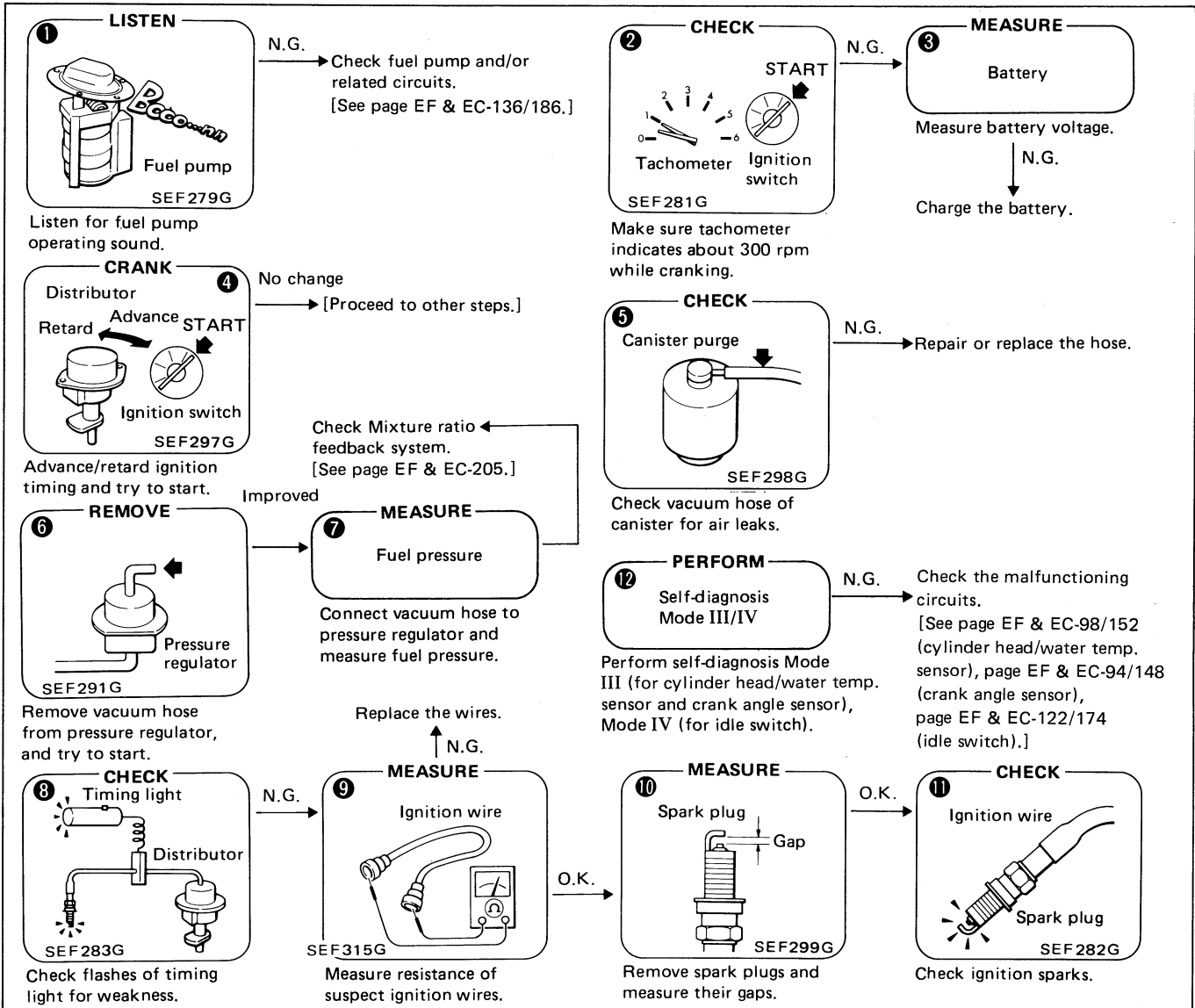

Diagnostic Table (Cont'd)

SYMPTOM & CONDITION 8 Hard to start – morning after a rainy day

POSSIBLE CAUSES		1	2	3	4	5
SPECIFICATIONS	Ignition sparks (weak)	○	○			○
IGNITION SYSTEM	Power transistor	○				○
	Ignition coil	○		○		○
	Center cable (ignition leaks)	○				○
	Ignition wires (ignition leaks)	○	○			○
	Distributor cap (ignition leaks)	○		○		○
	Spark plugs (improper gap)				○	○

SERVICE PROCEDURE

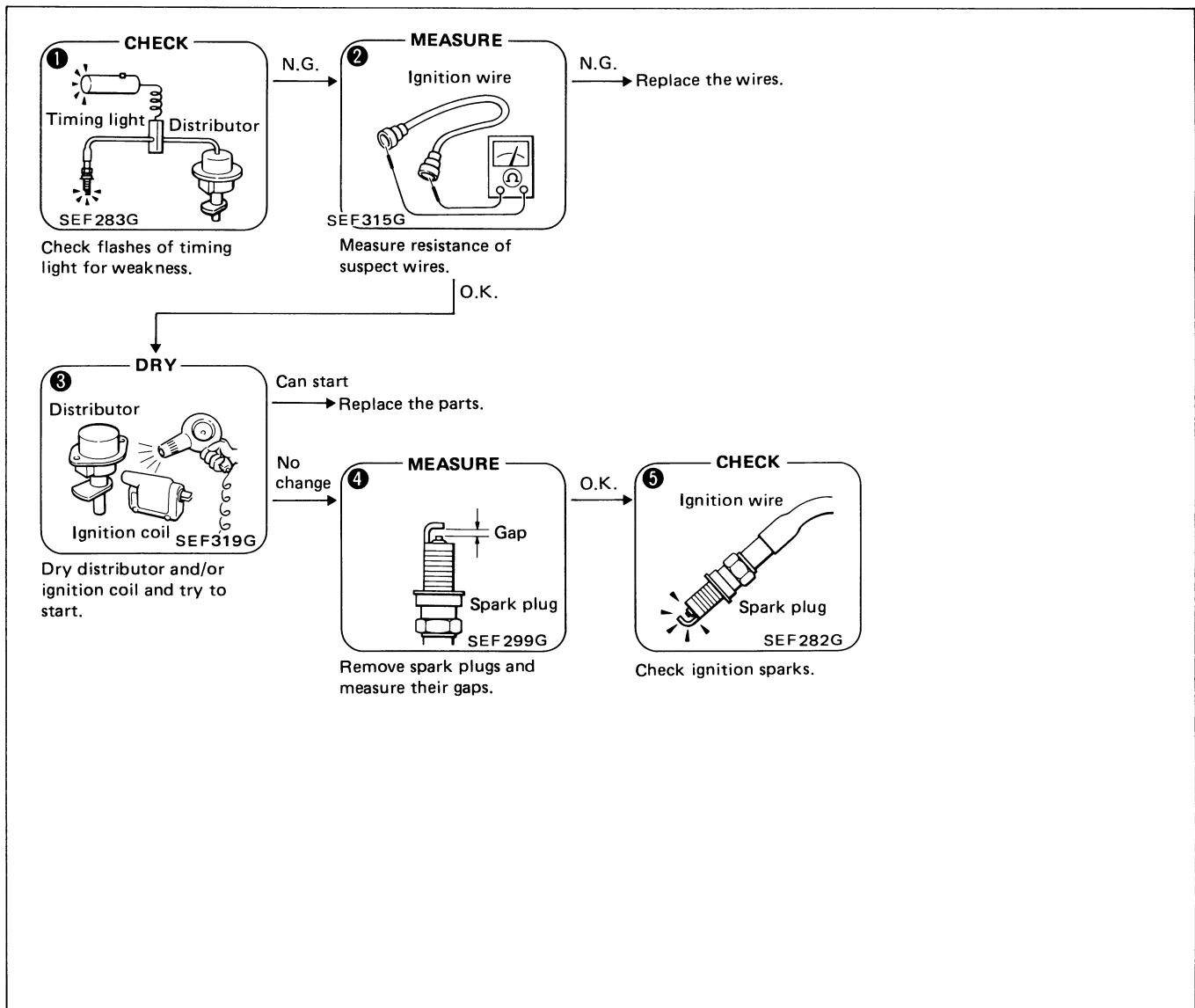

Diagnostic Table (Cont'd)

SYMPTOM & CONDITION 9 Abnormal idling – no fast idle

POSSIBLE CAUSES		1	2	3	4	5	6
SPECIFICATIONS	Mixture ratio	○	○		○		
	Ignition timing			○			
INTAKE SYSTEM	Blow-by hose (clogged)		○				
	Fast idle cam	○					
CONTROL SYSTEM	Cylinder head/Water temperature sensor					○	○

SERVICE PROCEDURE

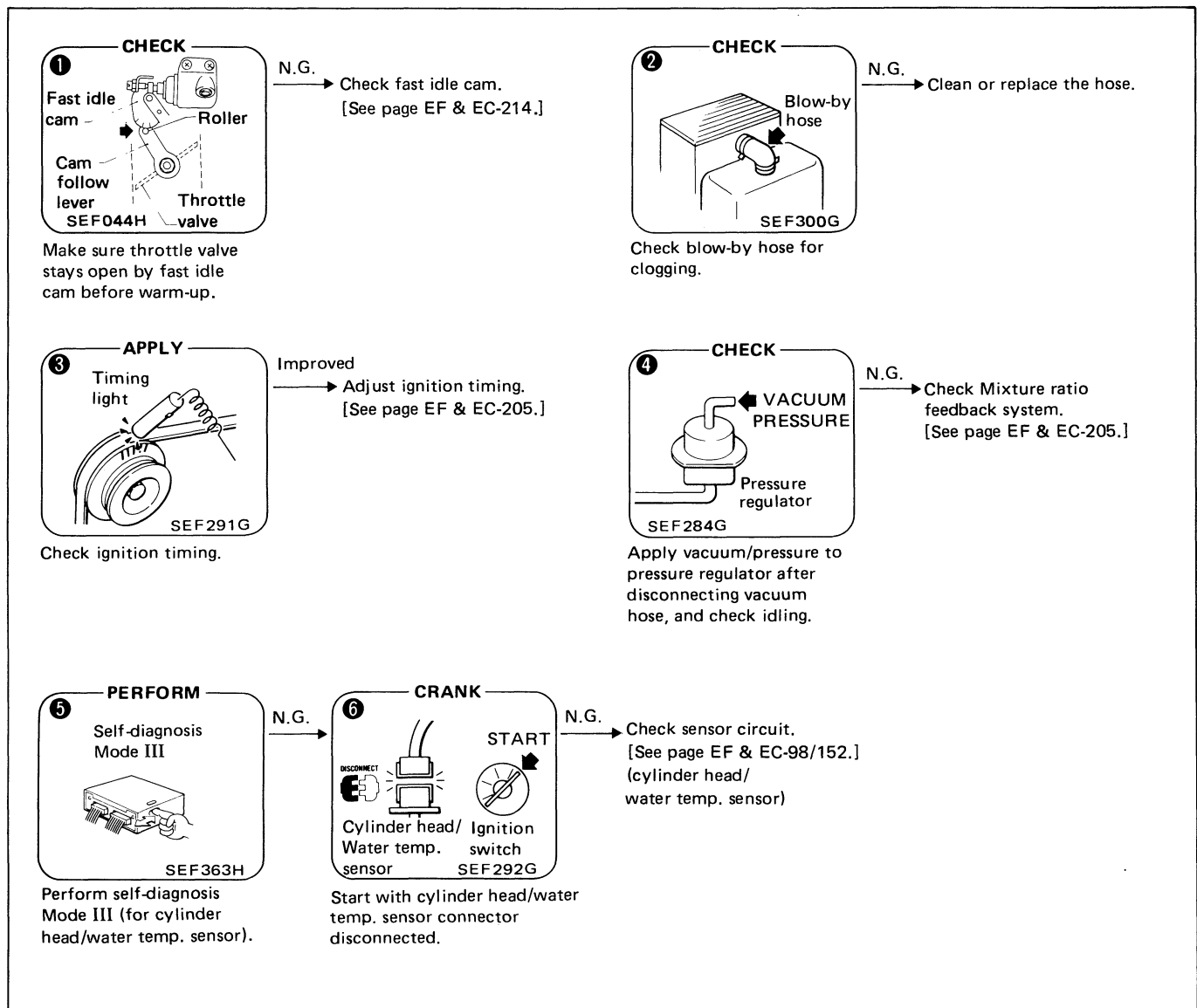

Diagnostic Table (Cont'd)

SYMPTOM & CONDITION 10 Abnormal idling – low idle (after warm-up)

POSSIBLE CAUSES		1	2	3	4	5	6	7
SPECIFICATIONS	Mixture ratio		○	○				
	Ignition timing (too retarded)	○						
INTAKE SYSTEM	Throttle body (with ports clogged)				○			
	Throttle valve (clogged)					○		
CONTROL SYSTEM	Crank angle sensor						○	
	Air flow meter						○	
	Cylinder head/Water temperature sensor						○	○
	Load switches (remaining OFF)							

SERVICE PROCEDURE

1 CHECK

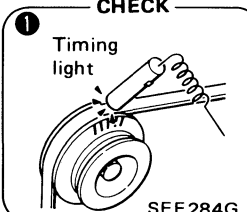

Timing light
SEF284G

Check ignition timing.

N.G.

Adjust ignition timing.
[See page EF & EC-205.]

2 CHECK

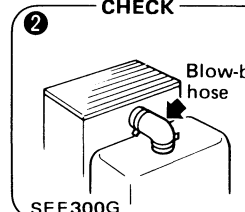

Blow-by hose
SEF300G

Check blow-by hose for clogging.

N.G.

Clean or replace the hose.

3 APPLY

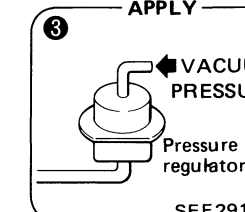

VACUUM PRESSURE
Pressure regulator
SEF291G

Apply vacuum/pressure to pressure regulator after disconnecting vacuum hose, and check idling.

Improved → Check Mixture ratio feedback system.
[See page EF & EC-205.]

No change → Check load signal circuit.
[See EL section.]

4 CHECK

Throttle body

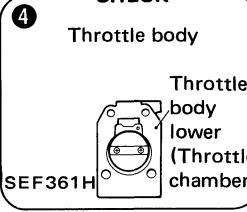

Throttle body lower (Throttle chamber)
SEF361H

Check throttle chamber ports for clogging.

N.G.

Clean the ports

5 CHECK

Throttle body

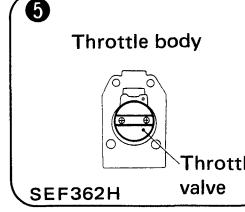

Throttle valve
SEF362H

Check throttle valve for clogging.

N.G.

Clean the valve.

PERFORM 6

Self-diagnosis Mode III
Self-diagnosis Mode V
SEF363H

Perform self-diagnosis Modes III and V (for air flow meter, and cylinder head/water temp. sensor).

N.G.

7 RUN

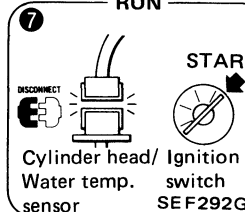

START
Cylinder head/ Water temp. sensor
Ignition switch
SEF292G

Start and run engine with cylinder head/water temp. sensor connector disconnected.

N.G. → Check the malfunctioning parts and/or circuits.
[See page EF & EC-96/150 (air flow meter), page EF & EC-98/152 (cylinder head/water temp. sensor).]

Diagnostic Table (Cont'd)

SYMPTOM & CONDITION 11 Abnormal idling – high idle (after warm-up)

POSSIBLE CAUSES		1	2	3	4	5	6	7	8	9	10	11
SPECIFICATIONS	Mixture ratio		○	○		○	○			○		
	Ignition timing (too advanced)	○										
INTAKE SYSTEM	Air duct (leaks)		○									
	Throttle chamber (air leaks)								○			
	Throttle valve (stuck control wire)								○			
	Intake manifold (gasket) (air leaks)		○									
	Fast idle cam			○								
	Idle speed control valve (remaining ON)							○				
	F.I.C.D. solenoid (remaining ON)				○							
CONTROL SYSTEM	Crank angle sensor										○	
	Air flow meter										○	
	Cylinder head/Water temperature sensor										○	○
	Idle switch (remaining OFF)								○	○		
	Load switches (remaining ON)				○			○				
OTHERS	Battery (voltage too low)											

SERVICE PROCEDURE

1 CHECK

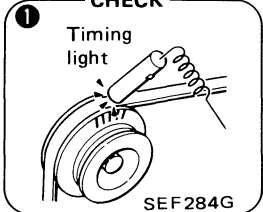

SEF284G

Check ignition timing.

N.G. → Adjust ignition timing. [See page EF & EC-205.]

2 CHECK

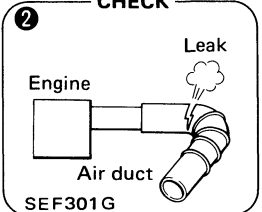

SEF301G

Check intake system for air leaks.

N.G. → Check throttle wire for rough sliding. Repair/replace the part.

O.K. →

3 PERFORM

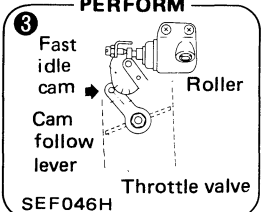

SEF046H

Make sure throttle valve stays closed by fast idle cam after warm-up.

N.G. → Check fast idle cam. [See page EF & EC-214.]

4 CHECK

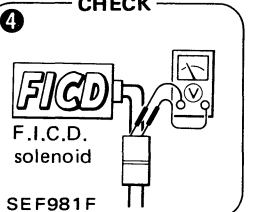

SEF981F

Check terminal voltage of F.I.C.D. solenoid while idling.

N.G. → Check the part and/or circuit. [See HA section.]

5 REMOVE

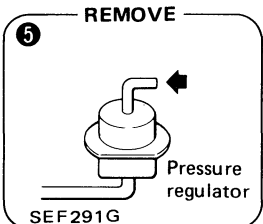

SEF291G

Remove vacuum hose from pressure regulator, and try to start.

Improved →

6 MEASURE

Fuel pressure

Connect vacuum hose to pressure regulator and measure fuel pressure.

Check Mixture ratio feedback system. [See page EF & EC-205.]

7 CHECK

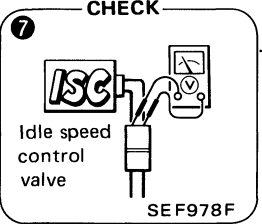

SEF978F

Check terminal voltage of idle speed control valve while idling.

N.G. → Check the part and/or circuit. [See page EF & EC-146/196.]

8 CHECK

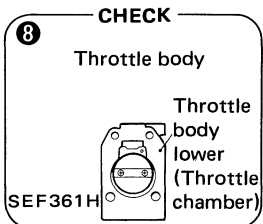

SEF361H

Check throttle body ports and valve for clogging.

N.G. → Clean the ports and/or throttle valve.

9 PERFORM

Self-diagnosis Mode IV

Perform self-diagnosis Mode IV (for idle switch).

N.G. → Check the idle switch circuit. [See page EF & EC-122/174.]

10 PERFORM

Self-diagnosis Mode III

Perform self-diagnosis Mode III (for cylinder head/water temp. sensor, crank angle sensor and air flow meter).

11 CRANK

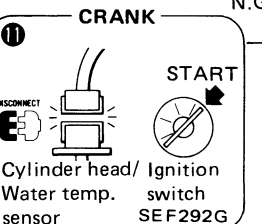

SEF292G

Start with cylinder head/water temp. sensor connector disconnected.

Diagnostic Table (Cont'd)

SYMPTOM & CONDITION 12 Unstable idling – before warm-up

POSSIBLE CAUSES		1	2	3	4	5	6	7	8
SPECIFICATIONS	Mixture ratio		○	○					
	Ignition timing	○							
INTAKE SYSTEM	Fast idle cam		○						
	Idle speed control valve (remaining OFF)				○				
CONTROL SYSTEM	Cylinder head/Water temperature sensor							○	○
E.G.R. SYSTEM	E.G.R. control valve (stuck open)					○			
	E.G.R. solenoid (remaining OFF)					○	○		

SERVICE PROCEDURE

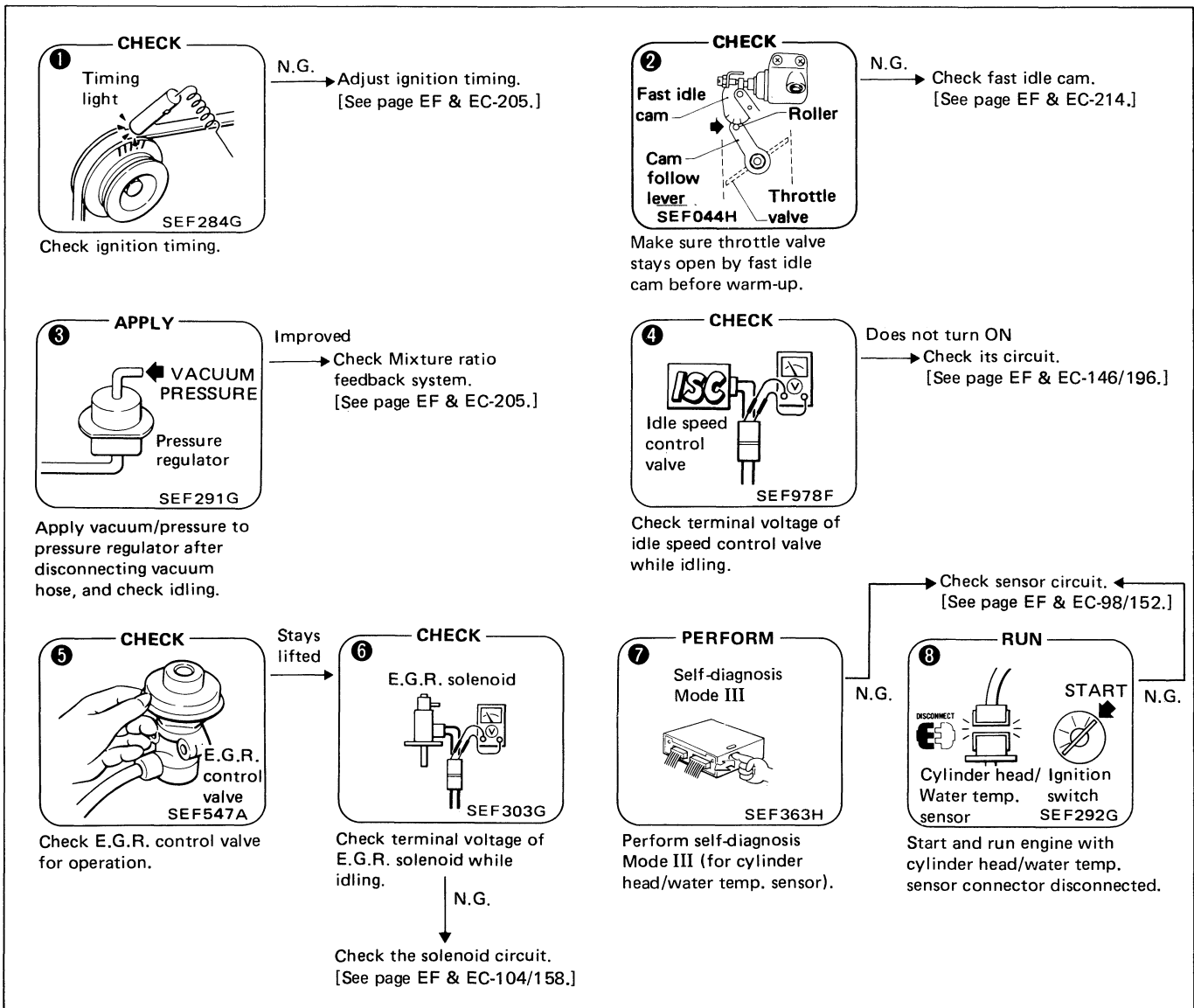

Diagnostic Table (Cont'd)

SYMPTOM & CONDITION 13 Unstable idling – after warm-up

POSSIBLE CAUSES		1	2	3	4	5	6	7	8	9	10	11
SPECIFICATIONS	Mixture ratio	○	○	○								
	Ignition sparks				○	○	○					
	Ignition timing							○				
	Compression pressure									○		
FUEL SYSTEM	Fuel line (clogged)											
	Canister (air leaks)			○								
IGNITION SYSTEM	Power transistor				○		○					
	Ignition coil				○		○					
	Ignition wires				○	○	○					
INTAKE SYSTEM	Blow-by hose (leaks)	○										
	Air duct (leaks)		○									
CONTROL SYSTEM	Idle switch											○
	Load switches											
E.G.R. SYSTEM	E.G.R. control valve									○		
	E.G.R. solenoid									○	○	

SERVICE PROCEDURE

1 CHECK

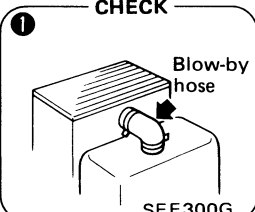

SEF300G

Check blow-by hose for leaks.

↓ N.G.

Repair/replace the hose.

2 CHECK

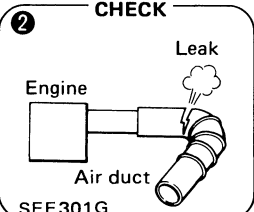

SEF301G

Check intake system for air leaks.

↓ N.G.

Repair/replace the part.

3 CHECK

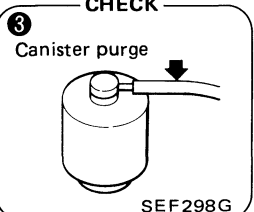

SEF298G

Check purge line for leaks.

↓ N.G.

Repair/replace the hose.

4 CHECK

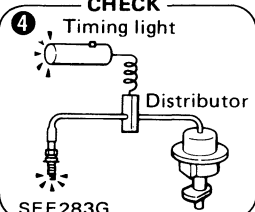

SEF283G

Check flashes of timing light for weakness.

↓ N.G.

5 MEASURE

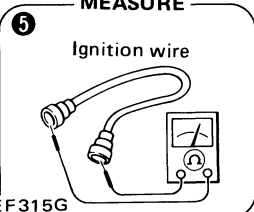

SEF315G

Measure resistance of suspect wires.

↓ N.G.

Replace the wire.

6 CHECK

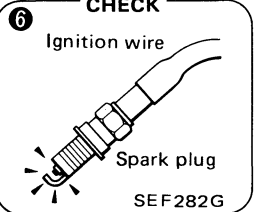

SEF282G

Remove spark plugs and check their ignition sparks.

7 CHECK

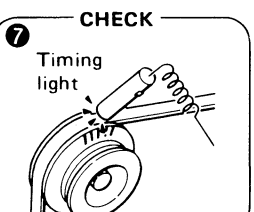

SEF284G

Check ignition timing.

↓ N.G.

Adjust ignition timing.
[See page EF & EC-205.]

8 MEASURE

COMPRESSION PRESSURE

SEF309G

Measure compression pressure.

↓ N.G.

Check cylinder head and gasket.
[See EM section.]

9 CHECK

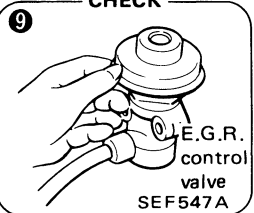

SEF547A

Check E.G.R. control valve for operation.

↓ Stays lifted

10 CHECK

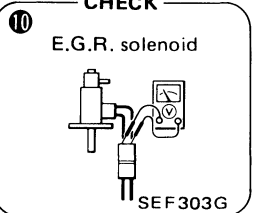

SEF303G

Check terminal voltage of E.G.R. solenoid while idling.

↓ N.G.

Check the solenoid circuit.
[See page EF & EC-104/158.]

11 PERFORM

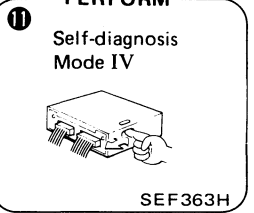

SEF363H

Perform self-diagnosis Mode IV (for idle switch).

↓ N.G.

Check the idle switch circuit.
[See page EF & EC-122/174.]

Diagnostic Table (Cont'd)

SYMPTOM & CONDITION 14 Poor driveability – stumble (while accelerating)

POSSIBLE CAUSES		1	2	3	4	5	6	7	8	9
SPECIFICATIONS	Mixture ratio				○		○	○		○
	Fuel pressure						○	○		
FUEL SYSTEM	Fuel filter (clogged)							○		
	Fuel line (clogged)							○		
	Injectors (clogged)								○	
IGNITION SYSTEM	Power transistor	○		○						
	Ignition coil	○		○						
	Ignition wires (ignition leaks)	○	○	○						
	Spark plugs (ignition leaks, improper gap)			○						
INTAKE SYSTEM	Air duct (leaks)				○					
CONTROL SYSTEM	Crank angle sensor	○							○	
	Air flow meter								○	
	Cylinder head/Water temperature sensor	○							○	
	Exhaust gas sensor								○	○
	Idle switch (remaining OFF)					○				
OTHERS	Fuel (poor quality)									

SERVICE PROCEDURE

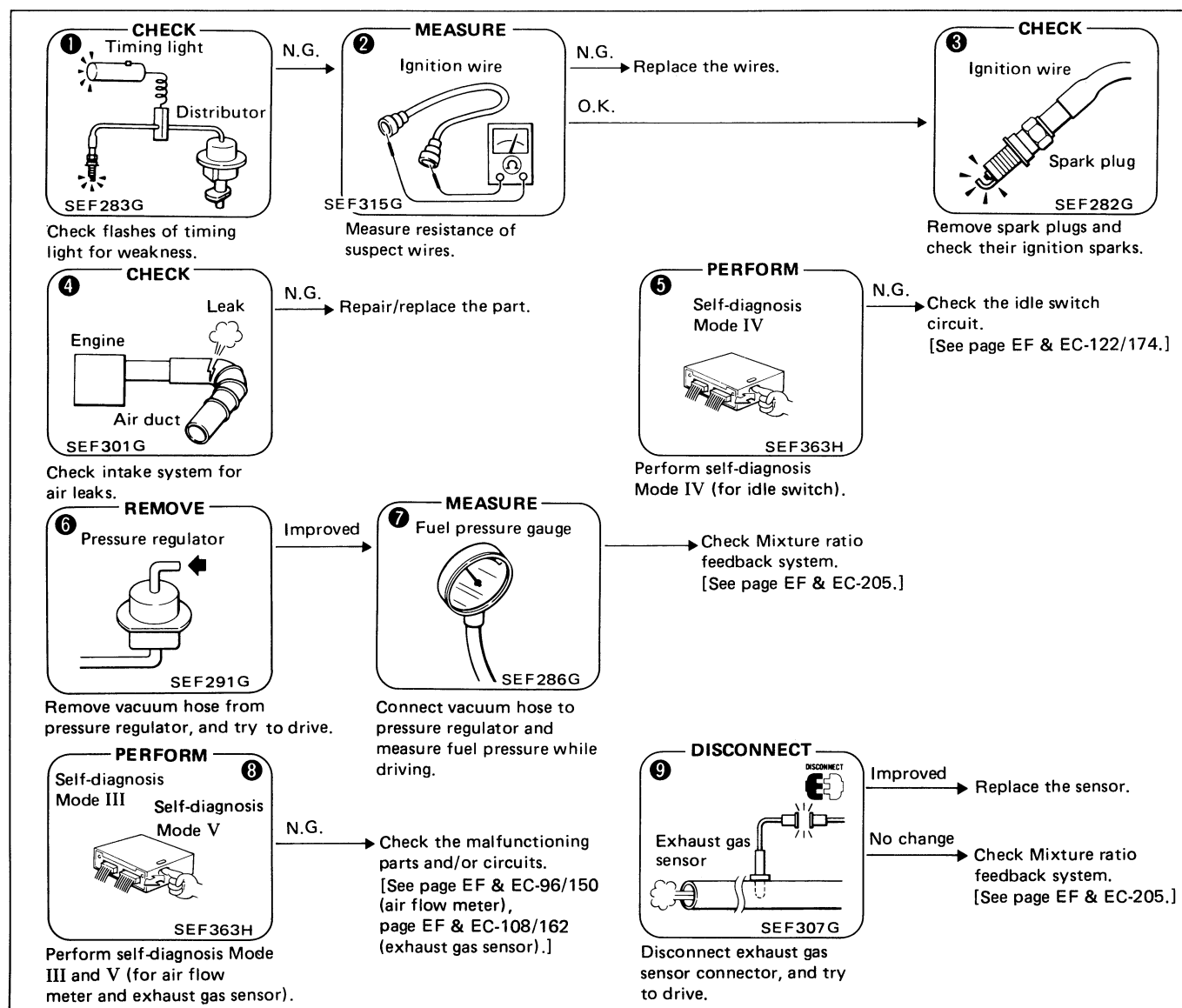

Diagnostic Table (Cont'd)

SYMPTOM & CONDITION 15 Poor driveability – surge (while cruising)

POSSIBLE CAUSES		1	2	3	4	5	6	7	8	9
SPECIFICATIONS	Mixture ratio (too lean)	○				○	○			○
	Fuel pressure (low)					○	○			
	Ignition timing		○							
IGNITION SYSTEM	(missing)								○	
INTAKE SYSTEM	Air duct (leaks)	○								
	Throttle chamber (air leaks)	○								
	Intake manifold (gasket) (air leaks)	○								
CONTROL SYSTEM	Crank angle sensor								○	
	Air flow meter								○	
	Exhaust gas sensor								○	○
	Idle switch							○		
E.G.R. SYSTEM	E.G.R. control valve (stuck open)			○						
	E.G.R. solenoid (remaining OFF)			○	○					
	E.G.R. vacuum hose (removed)			○						

SERVICE PROCEDURE

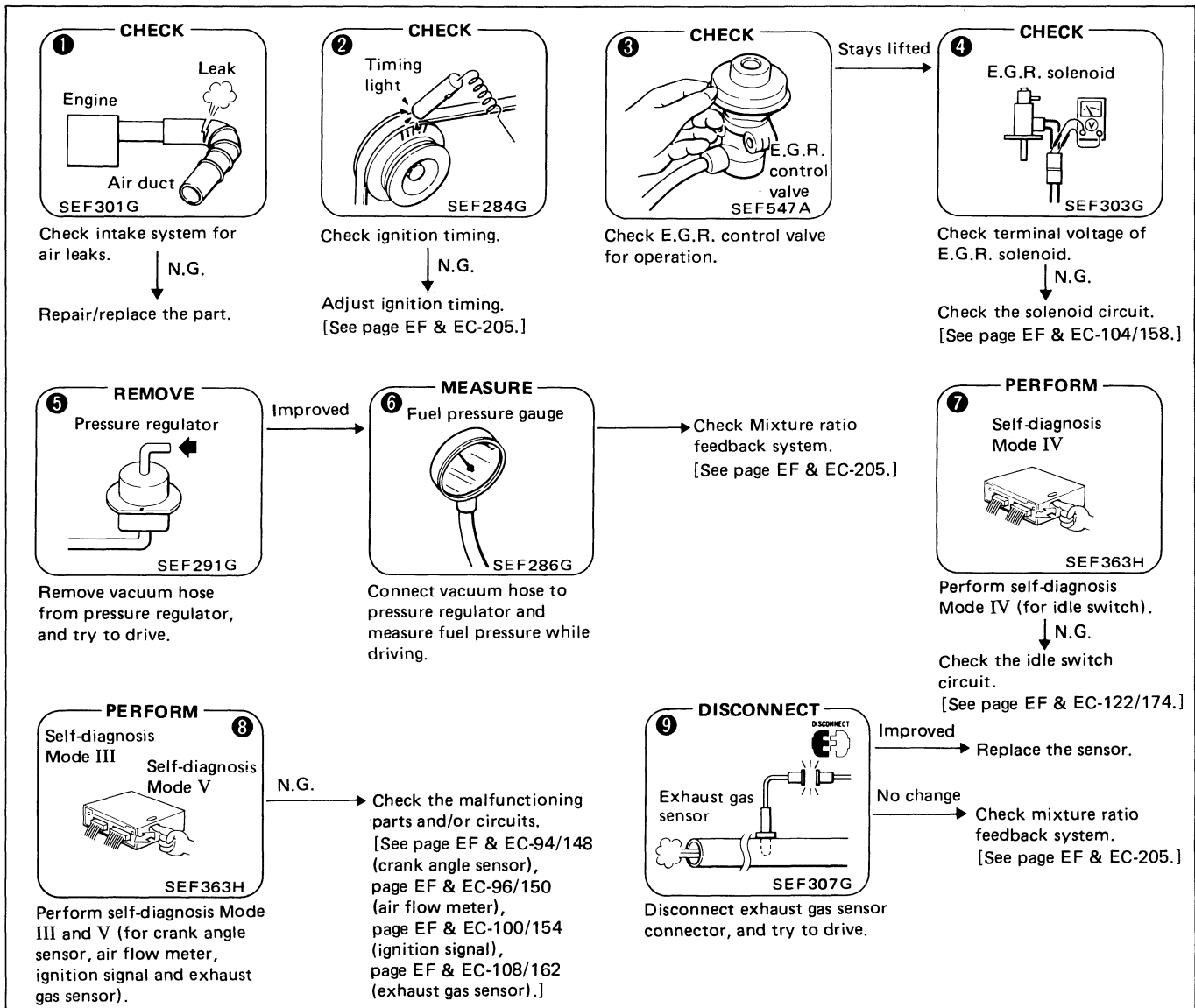

Diagnostic Table (Cont'd)

SYMPTOM & CONDITION 16 Poor driveability — lack of power

POSSIBLE CAUSES		1	2	3	4	5	6	7	8	9	10	11
SPECIFICATIONS	Fuel pressure								○	○		
	Ignition timing		○									
	Compression pressure (too low)							○				
FUEL SYSTEM	Fuel pump (low fuel output)									○		
	Fuel filter (clogged)									○		
	Fuel line (clogged)									○		
	Injectors (clogged)									○		
IGNITION SYSTEM	Ignition wires (ignition leaks)			○	○	○						
	Spark plugs (improper gap)					○						
INTAKE SYSTEM	Air cleaner element (clogged)	○										
	Throttle chamber (clogged)						○					
	Throttle valve (not open enough)						○					
CONTROL SYSTEM	Air flow meter										○	
	Exhaust gas sensor											○

SERVICE PROCEDURE

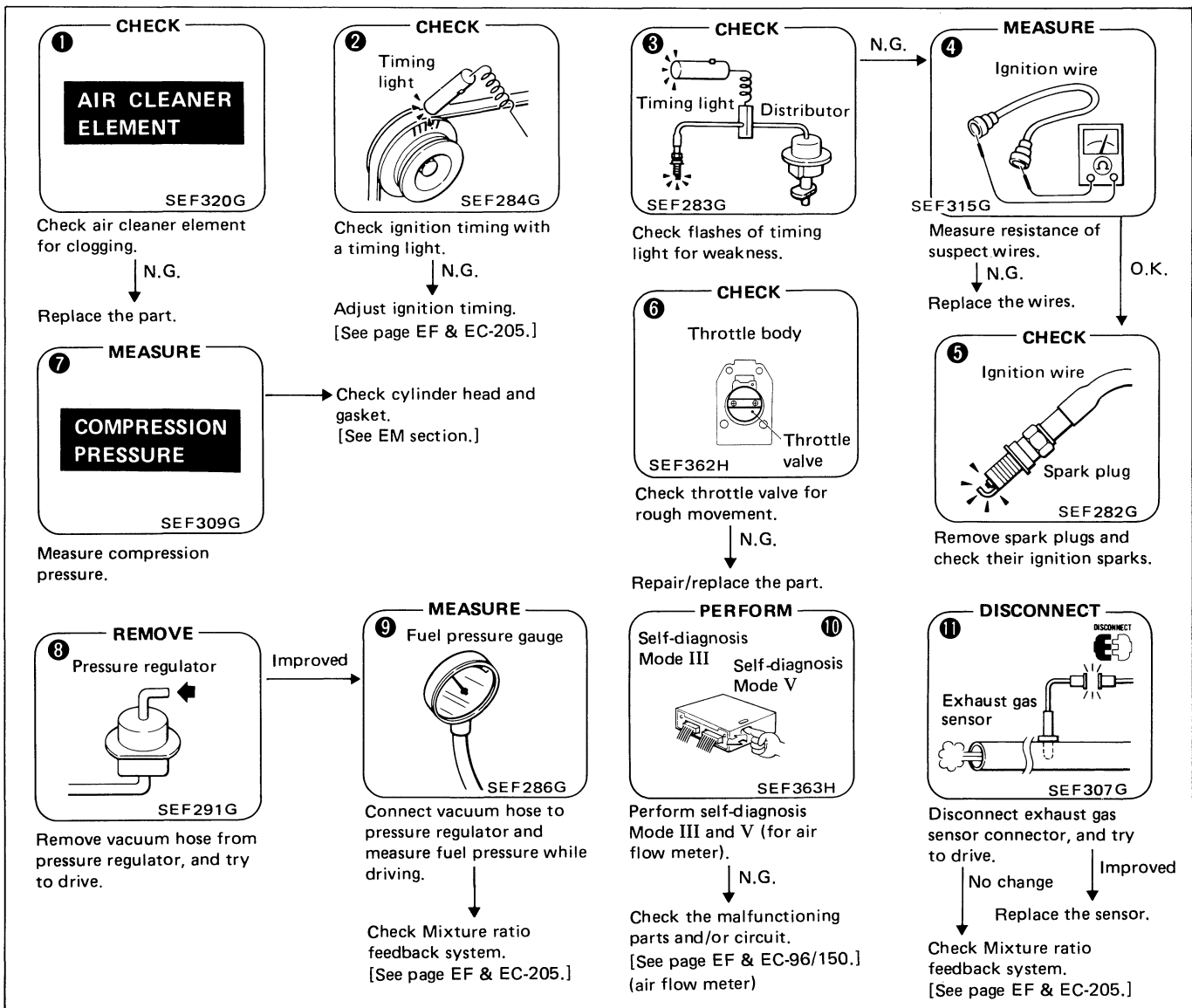

Diagnostic Table (Cont'd)

SYMPTOM & CONDITION 17 Poor driveability – detonation

POSSIBLE CAUSES		1	2	3	4	5
SPECIFICATIONS	Mixture ratio (too lean)			○	○	
	Fuel pressure (low)			○		
	Ignition timing (too advanced)		○			
FUEL SYSTEM	Fuel filter (clogged)				○	
	Fuel line (clogged)				○	
	Injectors (clogged)				○	
CONTROL SYSTEM	Crank angle sensor (improper 1°-signals)					○
	Air flow meter					○
	Cylinder head/Water temperature sensor					○
OTHERS	Water temperature (too high)	○				
	Fuel (low octane rating, poor quality)					

SERVICE PROCEDURE

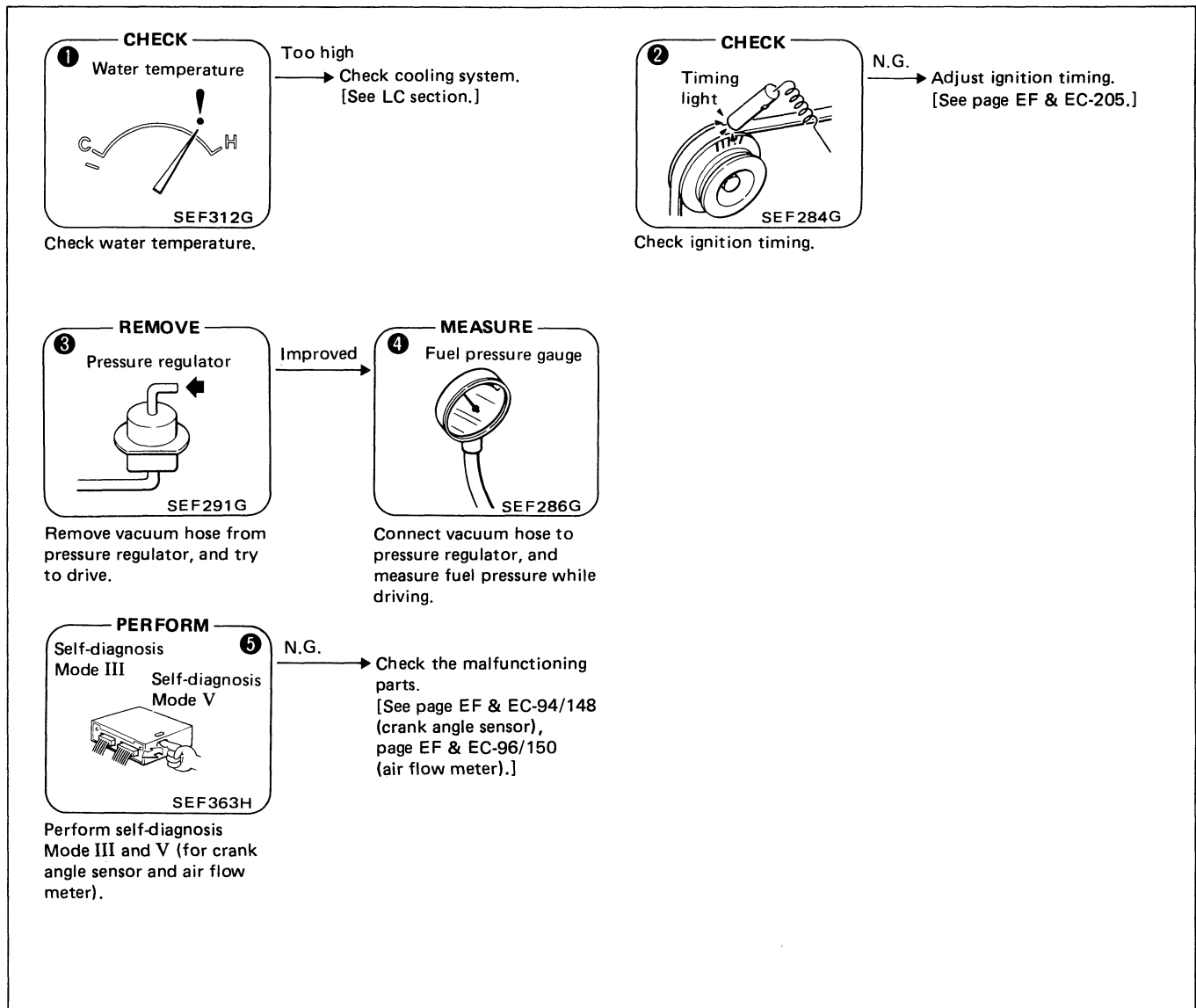

Diagnostic Table (Cont'd)

SYMPTOM & CONDITION 18 Engine stall – during start-up

POSSIBLE CAUSES		1	2	3	4	5	6	7	8	9
SPECIFICATIONS	Mixture ratio (too rich/too lean)							○	○	○
	Ignition sparks (weak)		○	○						
	Ignition timing	○								
	Compression pressure (too low)						○			
FUEL SYSTEM	Canister (too much evaporation to intake)							○		
IGNITION SYSTEM	Ignition wires (ignition leaks)		○	○	○					
	Spark plugs (wet with fuel, improper gap)				○					
INTAKE SYSTEM	Throttle valve (not open enough)					○				

SERVICE PROCEDURE

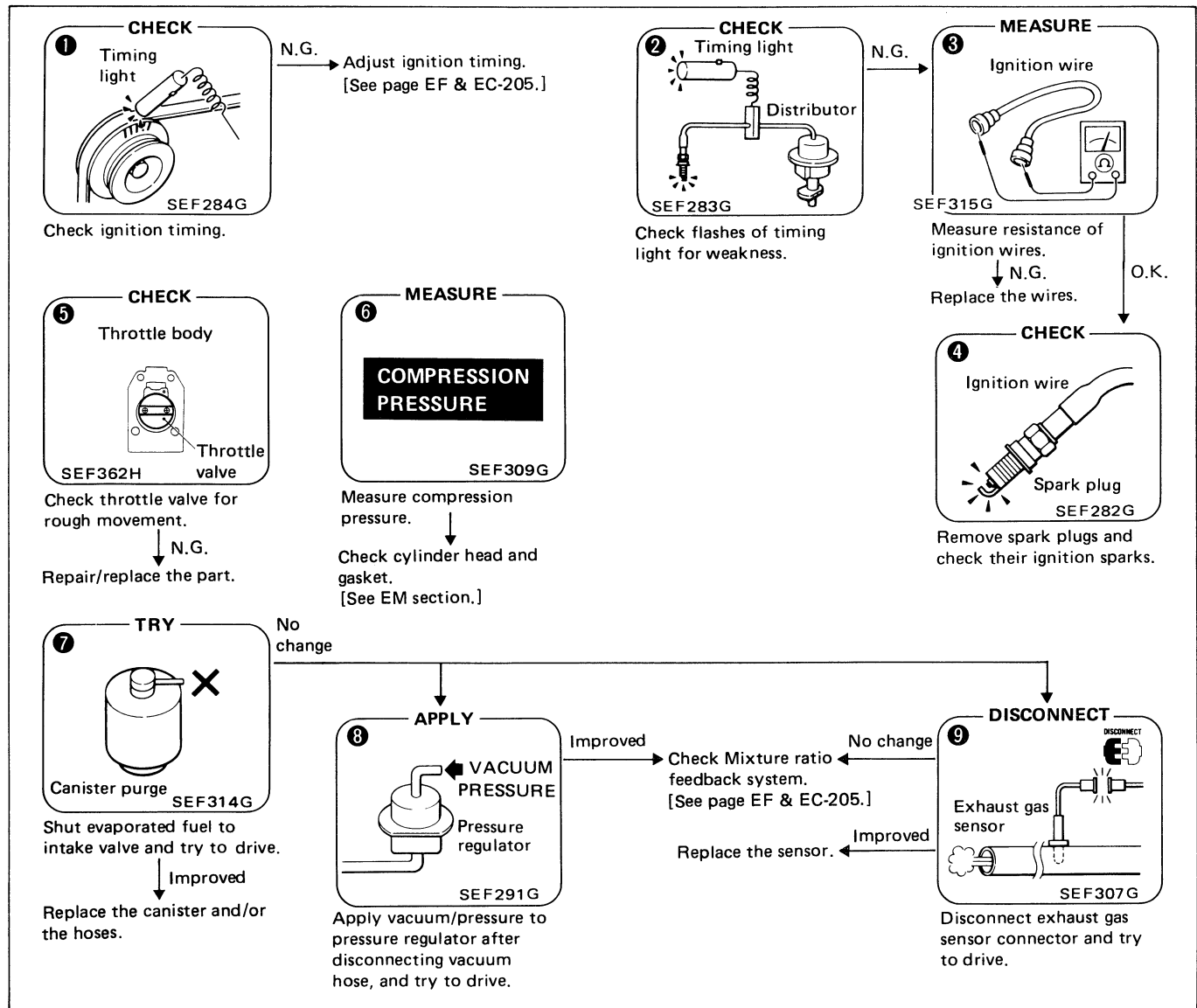

Diagnostic Table (Cont'd)

SYMPTOM & CONDITION 19 Engine stall – while idling

POSSIBLE CAUSES		1	2	3	4	5	6	7	8	9
SPECIFICATIONS	Mixture ratio (too rich/too lean)	○	○							
	Fuel pressure (low)	○	○							
	Ignition sparks (weak, missing)				○					
	Idle speed (low)			○						
FUEL SYSTEM	Fuel line (clogged)		○							
IGNITION SYSTEM	Spark plugs (wet with fuel, improper gap)					○	○			
INTAKE SYSTEM	Idle speed control valve (improper operation)			○				○		
	F.I.C.D. solenoid (improper operation)			○					○	
CONTROL SYSTEM	Idle switch (remaining OFF)									○
	Neutral switch (remaining OFF)			○						
	Load switches (remaining OFF)							○	○	

SERVICE PROCEDURE

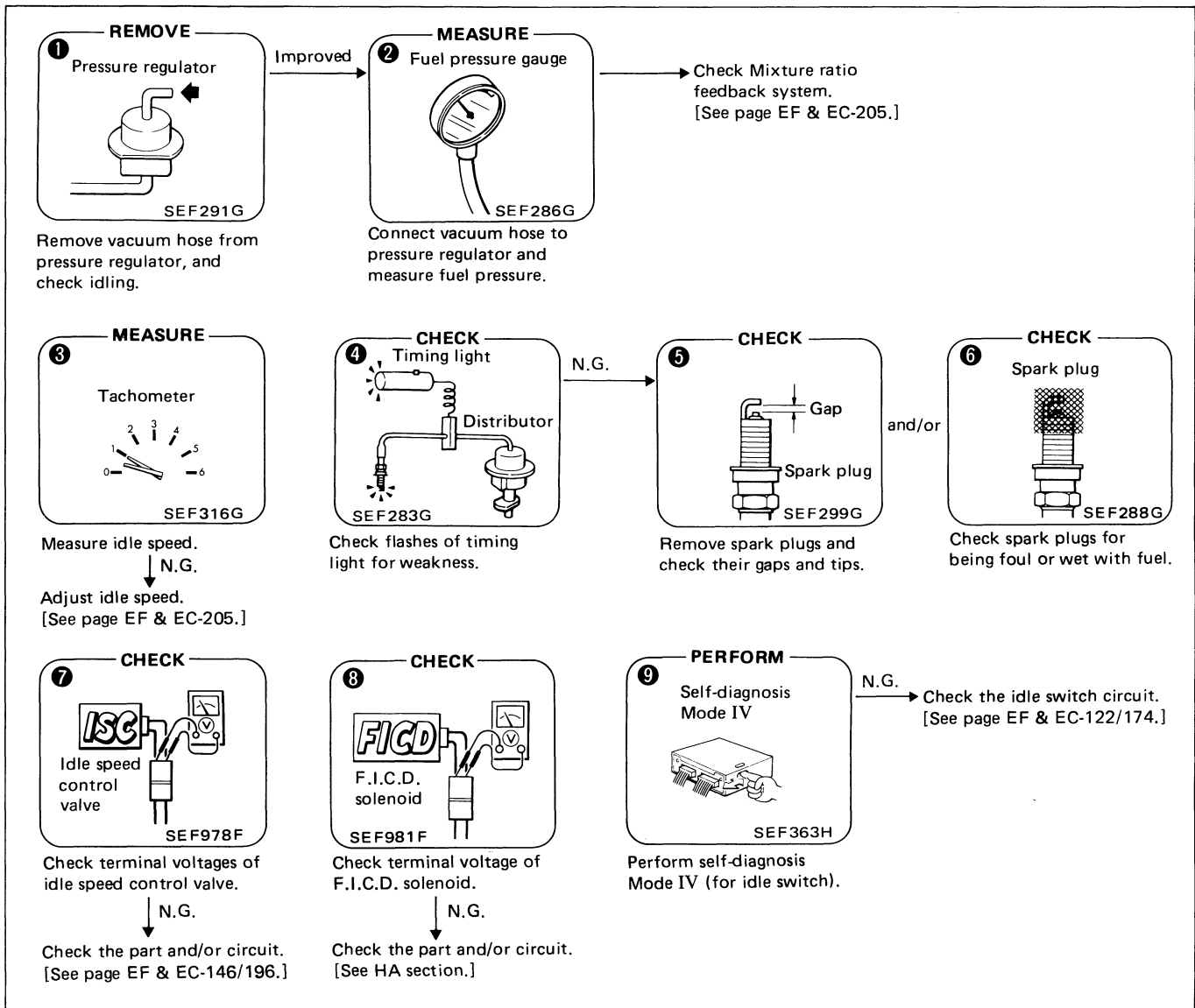

Diagnostic Table (Cont'd)

SYMPTOM & CONDITION 20 Engine stall – while accelerating

POSSIBLE CAUSES		1	2	3	4	5	6	7
SPECIFICATIONS	Mixture ratio					○	○	
	Ignition sparks (weak, missing)	○	○	○				
	Compression pressure (low)				○			
CONTROL SYSTEM	Crank angle sensor	○						○
	Air flow meter							○
	Exhaust gas sensor					○	○	

SERVICE PROCEDURE

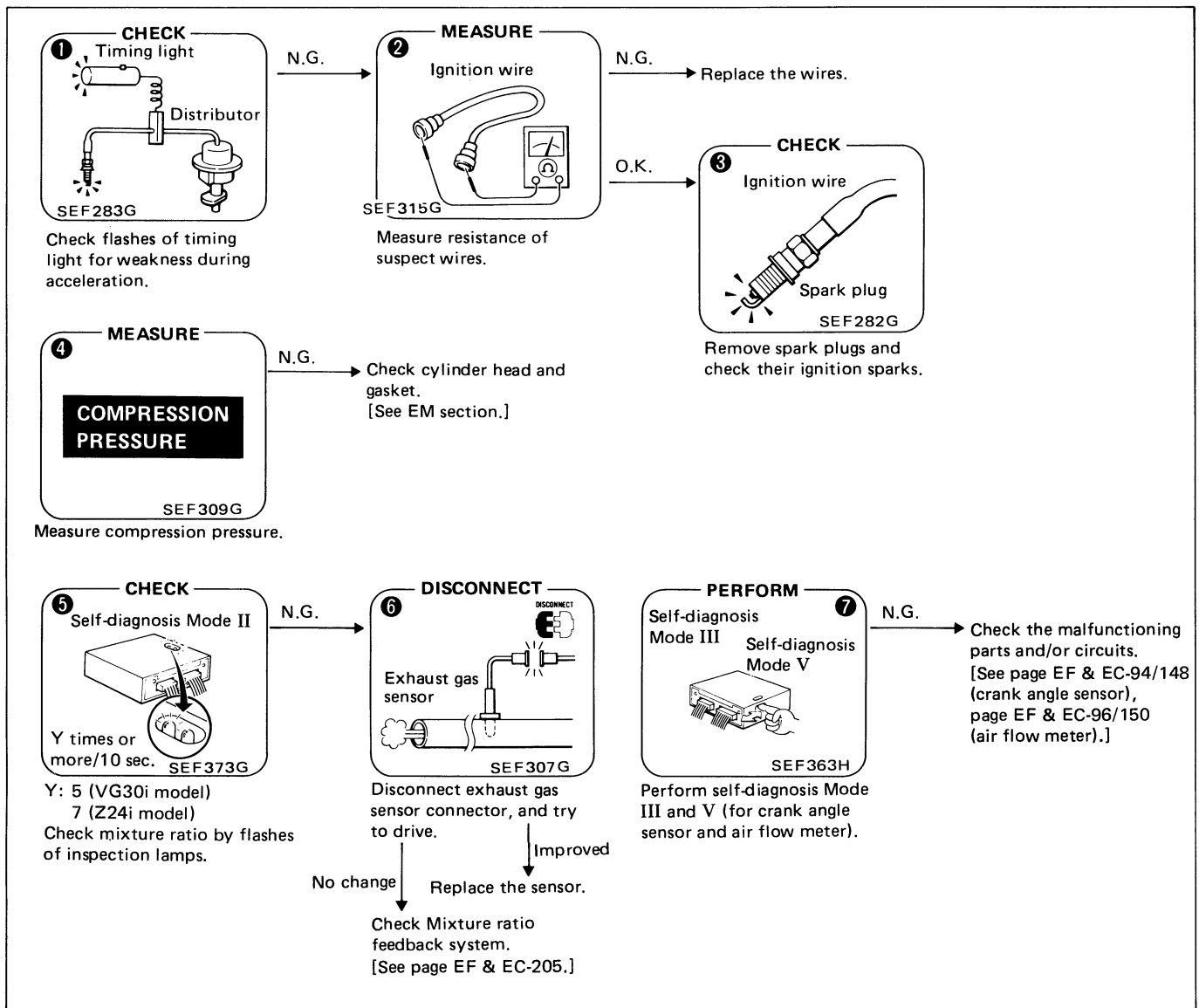

Diagnostic Table (Cont'd)

SYMPTOM & CONDITION 21 Engine stall – while cruising

POSSIBLE CAUSES		1	2	3	4	5	6
SPECIFICATIONS	Mixture ratio				○	○	
	Ignition sparks (weak, missing)	○	○	○			
CONTROL SYSTEM	Crank angle sensor						○
	Air flow meter						○

SERVICE PROCEDURE

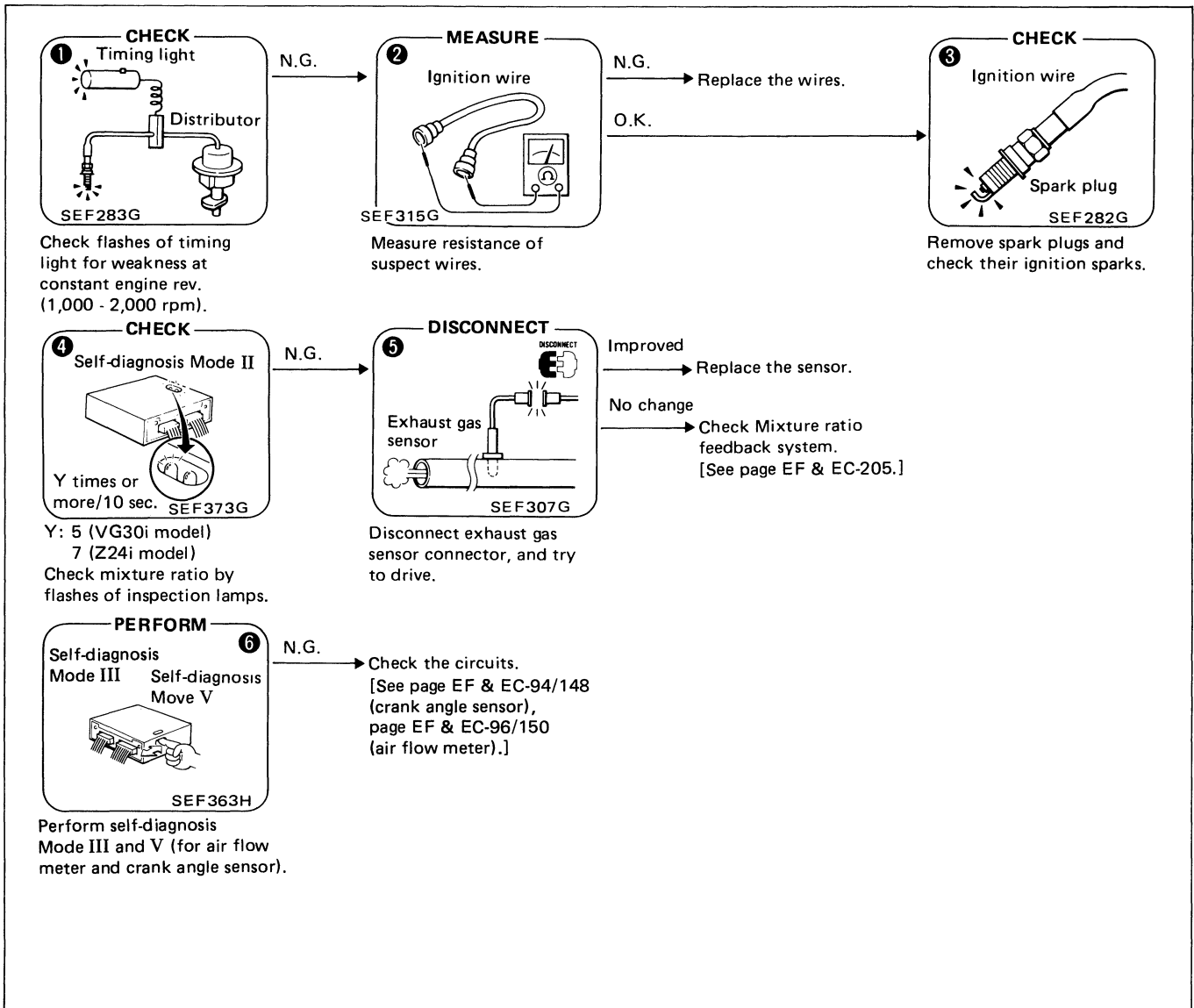

Diagnostic Table (Cont'd)

SYMPTOM & CONDITION 22 Engine stall – while decelerating/just after stopping

POSSIBLE CAUSES		1	2	3	4	5	6
SPECIFICATIONS	Mixture ratio					○	○
	Ignition sparks (missing)	○					
	Idle speed (too low)			○			
IGNITION SYSTEM	(missing)	○	○				
INTAKE SYSTEM	Idle speed control valve (remaining OFF)			○	○		
CONTROL SYSTEM	Exhaust gas sensor (malfunctioning feedback control)					○	○
	Crank angle sensor		○				
	Idle switch (remaining OFF)			○			
	Load switches (remaining OFF)			○	○		

SERVICE PROCEDURE

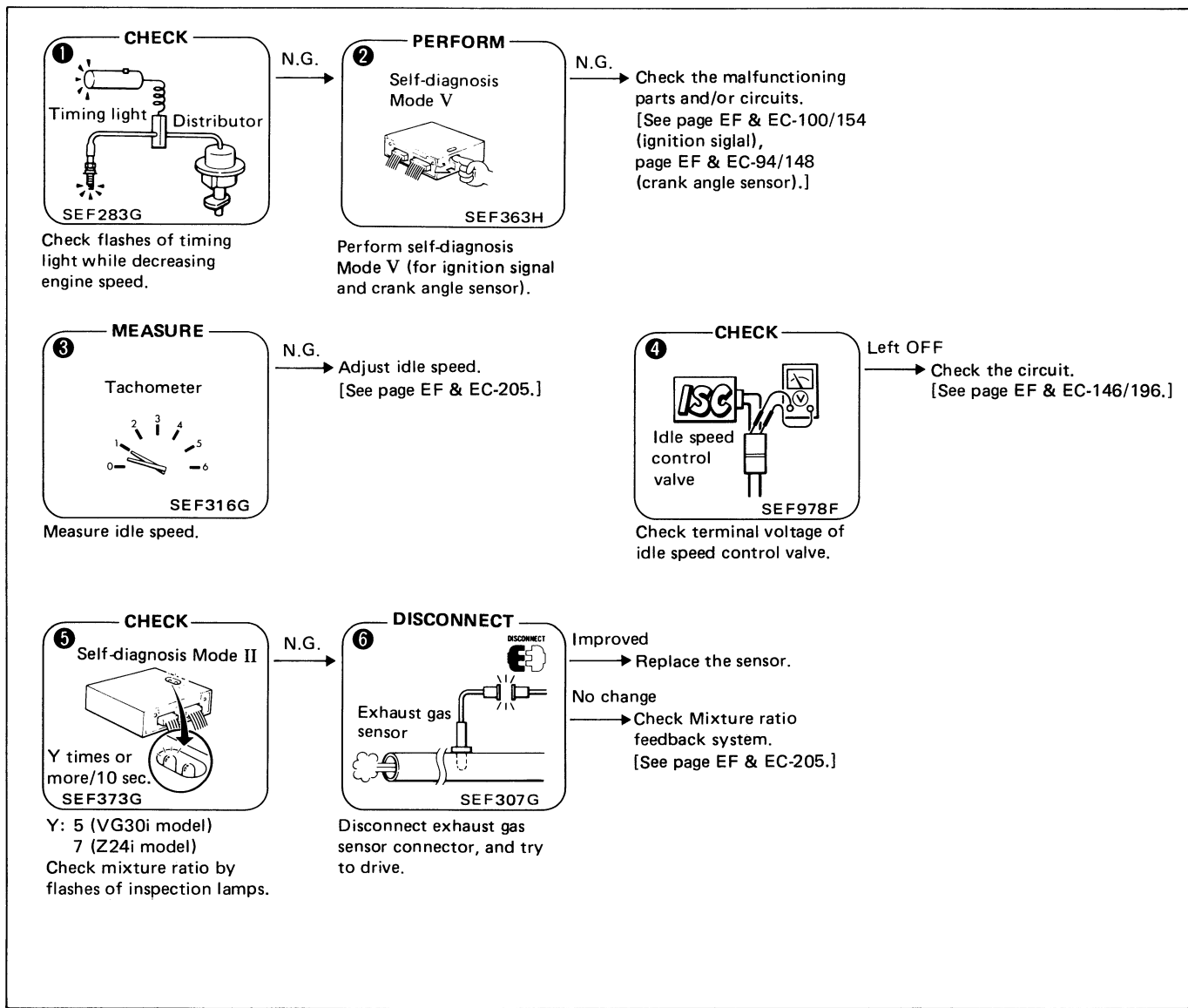

Diagnostic Table (Cont'd)

SYMPTOM & CONDITION 23 Engine stall – while loading

POSSIBLE CAUSES		1	2	3	4	5
SPECIFICATIONS	Ignition timing		○			
	Idle speed (too low)	○				
INTAKE SYSTEM	Idle speed control valve (remaining OFF)	○		○		
	F.I.C.D. solenoid (remaining OFF)	○			○	
CONTROL SYSTEM	Idle switch (remaining OFF)	○				○
	Load switches (remaining OFF)	○		○	○	

SERVICE PROCEDURE

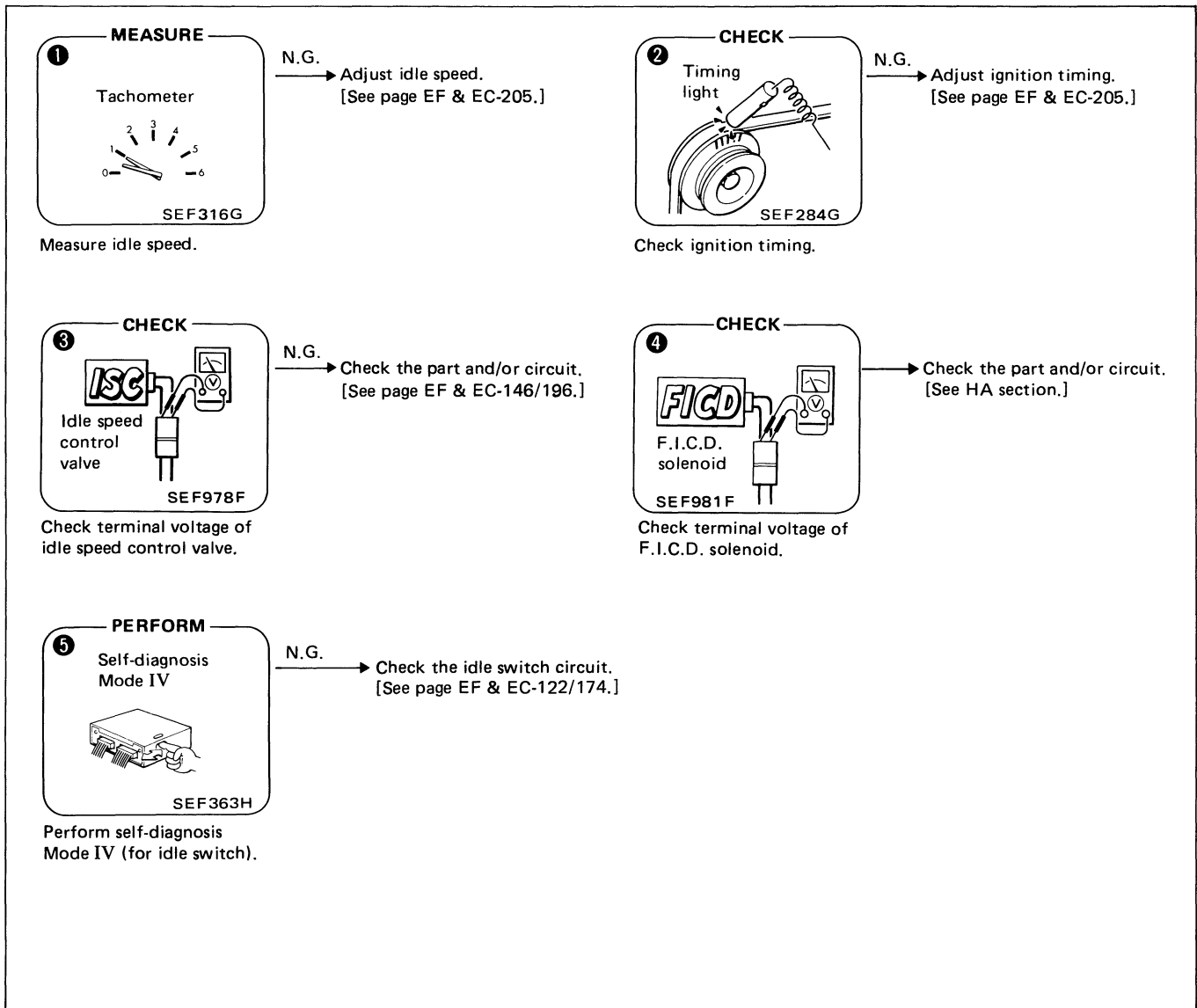

Diagnostic Table (Cont'd)

SYMPTOM & CONDITION 24 Backfire – through the intake

POSSIBLE CAUSES		1	2	3	4	5	6	7
SPECIFICATIONS	Mixture ratio (too lean)	○		○		○	○	
	Ignition timing (too retarded)		○					
FUEL SYSTEM	Injectors (clogged)				○			
INTAKE SYSTEM	Air duct (air leaks)	○						
	Intake manifold (gaskets) (air leaks)	○						
CONTROL SYSTEM	Air flow meter							○
	Exhaust gas sensor					○	○	

SERVICE PROCEDURE

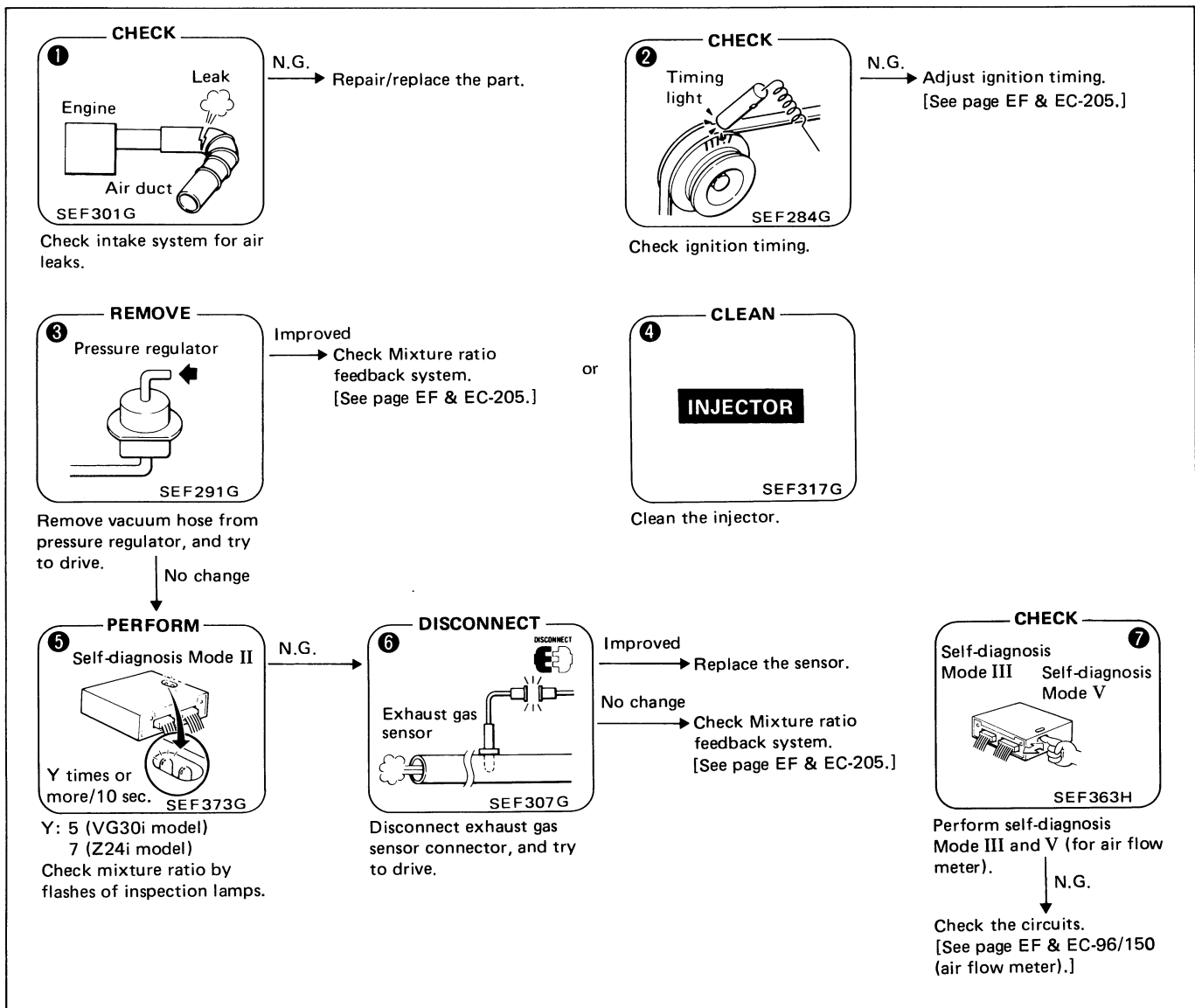

Diagnostic Table (Cont'd)

SYMPTOM & CONDITION 25 Backfire – through the exhaust

POSSIBLE CAUSES		1	2	3	4	5	6
SPECIFICATIONS	Mixture ratio (too rich)	○	○				
FUEL SYSTEM	Injectors (fuel leaks)		○				
IGNITION SYSTEM	(missing)				○		
INTAKE SYSTEM	Air cleaner element (clogged)	○					
	A.I.V. (always operating)					○	
	A.I.V. solenoid (remaining ON)					○	○
CONTROL SYSTEM	Idle switch (remaining OFF)			○			

SERVICE PROCEDURE

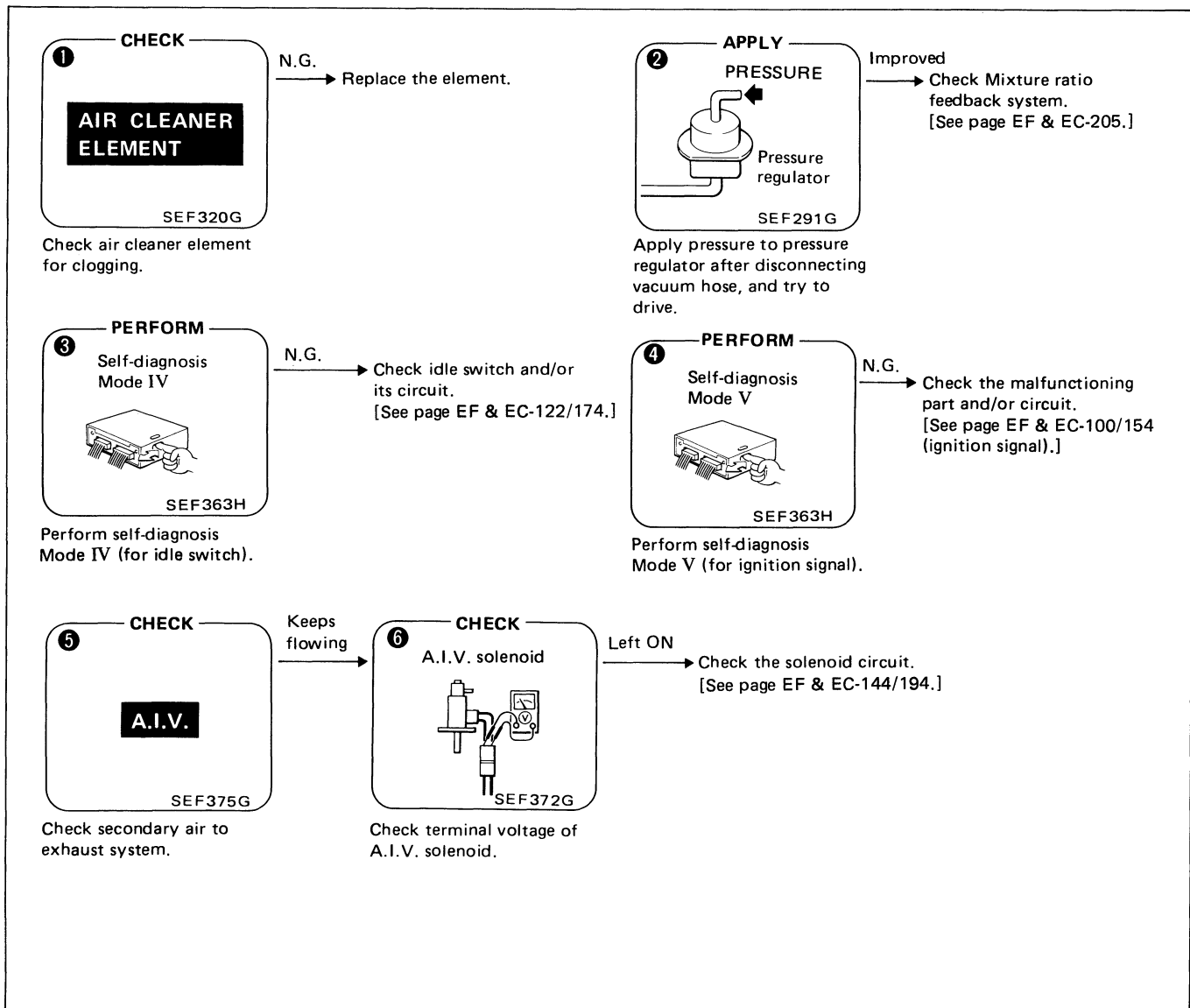

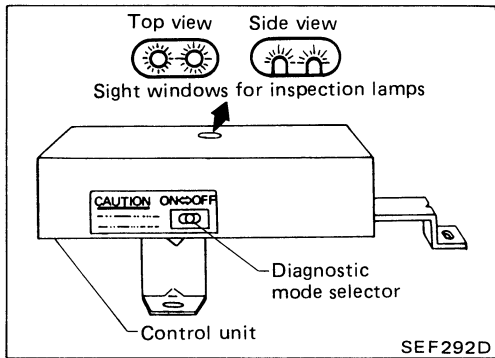

Description

The self-diagnosis is useful to diagnose malfunctions in major sensors and actuators of the E.C.C.S. system. There are 5 modes in the self-diagnosis system.

1. Mode I – Mixture ratio feedback control monitor A

- During closed loop condition:
The green inspection lamp turns ON when lean condition is detected and goes OFF by rich condition.
- During open loop condition:
The green inspection lamp remains ON or OFF.

2. Mode II – Mixture ratio feedback control monitor B

- The green inspection lamp function is the same as Mode I.
- During closed loop condition:
The red inspection lamp turns ON and OFF simultaneously with the green inspection lamp when the mixture ratio is controlled within the specified value.
- During open loop condition:
The red inspection lamp remains ON or OFF.

3. Mode III – Self-diagnosis

This mode is the same as the former self-diagnosis in self-diagnosis mode.

4. Mode IV – Switches ON/OFF diagnosis

During this mode, the inspection lamps monitor the switch ON-OFF condition.

- Idle switch
- Starter switch
- Vehicle speed sensor

5. Mode V – Real time diagnosis

The moment the malfunction is detected, the display will be presented immediately. That is, the condition at which the malfunction occurs can be found by observing the inspection lamps during driving test.

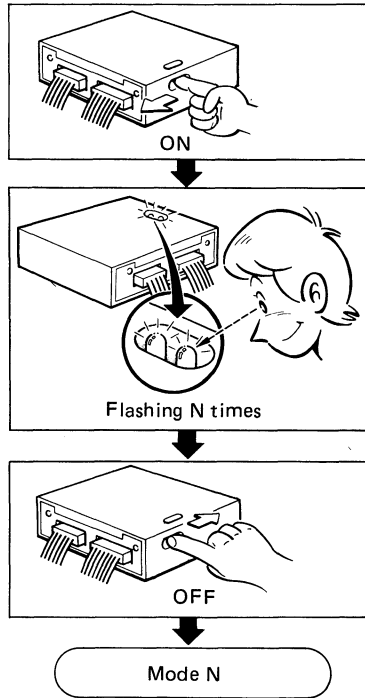

SEF781E

**Description (Cont'd)
SWITCHING THE MODES**

1. Turn ignition switch "ON".
2. Turn diagnostic mode selector "ON" and wait the inspection lamps flash.
3. Count the number of the flashing time, and after the inspection lamps have flashed the number of the required mode, turn diagnostic mode selector "OFF" immediately.

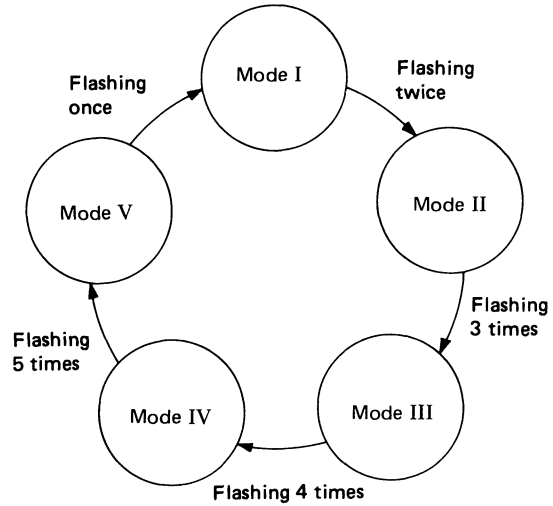

SEF989D

When the ignition switch is turned off during diagnosis, in each mode, and then turned back on again after the power to the E.C.U. has dropped off completely, the diagnosis will automatically return to Mode I.

The stored memory would be lost if:

1. Battery terminal is disconnected.
2. After selecting Mode III, Mode IV is selected.

However, if the diagnostic mode selector is kept turned fully clockwise, it will continue to change in the order of Mode I → II → III → IV → V → I ... etc., and in this state the stored memory will not be erased.

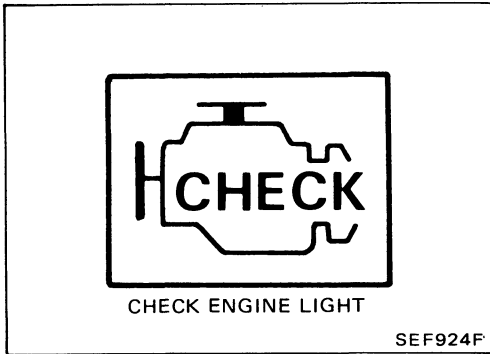

Description (Cont'd)

CHECK ENGINE LIGHT (For California only)

This vehicle has a check engine light on instrument panel. This light comes ON under the following conditions:

- 1) When ignition switch is turned "ON" (for bulb check).
- 2) When systems related to emission performance malfunction in Mode I (with engine running).
 - This check engine light always illuminates and is synchronous with red L.E.D.
 - Malfunction systems related to emission performance can be detected by self-diagnosis, and they are clarified as self-diagnostic codes in Mode III.
- 3) Check engine light will come "ON" only when malfunction is sensed.

The check engine light will turn off when normal operation is resumed. Mode III memory must be cleared as the contents remain stored.

Code No.	Malfunction
12	Air flow meter circuit
13	Cylinder head/water temperature sensor circuit
31	E.C.U. (E.C.C.S. control unit)
32	E.G.R. function
33	Exhaust gas sensor circuit
35	Exhaust gas temperature sensor circuit
43	Throttle sensor circuit
45	Injector leak

Use the following diagnostic flowchart to check and repair a malfunctioning system.

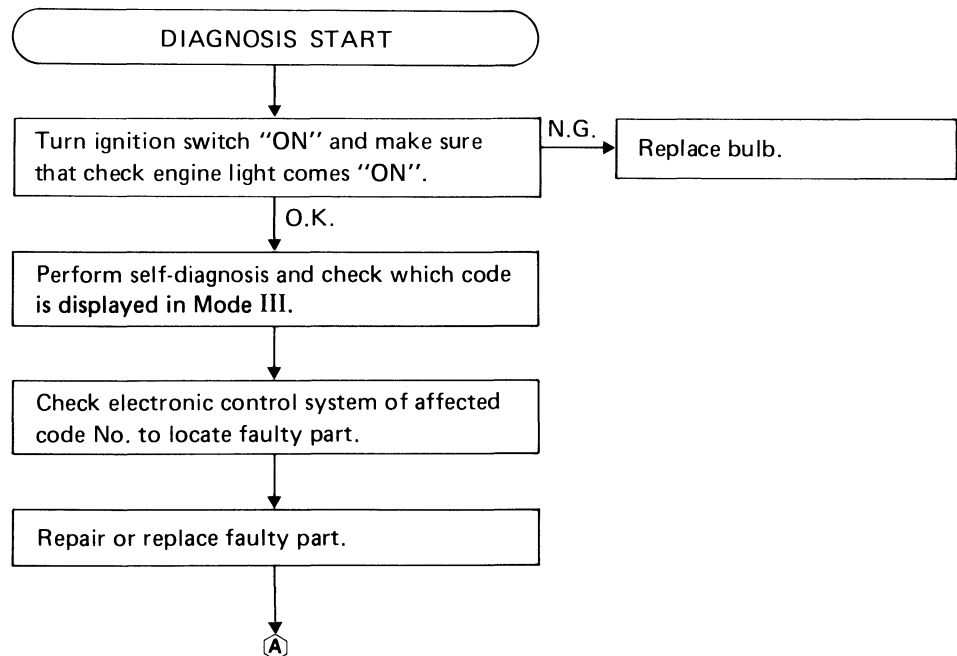

Description (Cont'd)

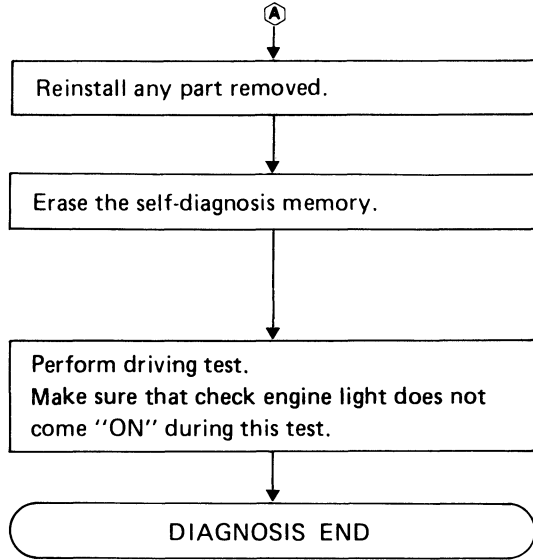

- **Methods of erasing memories differ with systems. Read the manual before diagnosing systems.**

- **After repairs, test drive to check that check engine light does not come on.**

- **Test driving modes differ with systems. Read the manual before test driving.**

Modes I & II — Mixture Ratio Feedback Control Monitors A & B

In these modes, the control unit provides the Air-fuel ratio monitor presentation and the Air-fuel ratio feedback coefficient monitor presentation.

Mode	LED	Engine stopped (Ignition switch "ON")	Engine running		
			Open loop condition	Closed loop condition	
Mode I (Monitor A)	Green	ON	* Remains ON or OFF	Blinks	
	Red	ON	Except for California model ● OFF	For California model ● ON: when CHECK ENGINE LIGHT ITEMS are stored in the E.C.U. ● OFF: except for the above condition	
Mode II (Monitor B)	Green	ON	* Remains ON or OFF	Blinks	
	Red	OFF	* Remains ON or OFF (synchronous with green LED)	Compensating mixture ratio	
				More than 5% rich	Between 5% lean and 5% rich
			OFF	Synchronized with green LED	Remains ON

*: Maintains conditions just before switching to open loop

Mode III — Self-Diagnostic System

The E.C.U. constantly monitors the function of these sensors and actuators, regardless of ignition key position. If a malfunction occurs, the information is stored in the E.C.U. and can be retrieved from the memory by turning on the diagnostic mode selector, located on the side of the E.C.U. When activated, the malfunction is indicated by flashing a red and a green L.E.D. (Light Emitting Diode), also located on the E.C.U. Since all the self-diagnostic results are stored in the E.C.U.'s memory even intermittent malfunctions can be diagnosed.

A malfunctioning part's group is indicated by the number of both the red and the green L.E.D.s flashing. First, the red L.E.D. flashes and the green flashes follow. The red L.E.D. refers to the number of tens while the green one refers to the number of units. For example, when the red L.E.D. flashes once and then the green one flashes twice, this means the number "12" showing the air flow meter signal is malfunctioning. In this way, all the problems are classified by the code numbers.

- **When engine fails to start, crank engine more than two seconds before starting self-diagnosis.**
- **Before starting self-diagnosis, do not erase stored memory. If doing so, self-diagnosis function for intermittent malfunctions would be lost.**

The stored memory would be lost if:

1. **Battery terminal is disconnected.**
2. **After selecting Mode III, Mode IV is selected.**

DISPLAY CODE TABLE

X: Available
 —: Not available
 *: Check engine light item

Code No.	Detected items	California	Non-California
11	Crank angle sensor circuit	X	X
12	Air flow meter circuit	X*	X
13	Cylinder head/Water temperature sensor circuit	X*	X
21	Ignition signal missing in primary coil	X	X
31	E.C.U. (E.C.C.S. control unit)	X*	X
32	E.G.R. circuit	X*	—
33	Exhaust gas sensor circuit	X*	X
35	Exhaust gas temperature sensor circuit	X*	—
43	Throttle sensor circuit	X*	X
45	Injector leak	X*	—
51	Injector (VG30i model only)	X	X
55	No malfunction in the above circuit	X	X

Mode III — Self-Diagnostic System (Cont'd)

RETENTION OF DIAGNOSTIC RESULTS

The diagnostic result is retained in E.C.U. memory until the starter is operated fifty times after a diagnostic item is judged to be malfunctioning. The diagnostic result will then be cancelled automatically. If a diagnostic item which has been judged to be malfunctioning and stored in memory is again judged to be malfunctioning before the starter is operated fifty times, the second result will replace the previous one. It will be stored in E.C.U. memory until the starter is operated fifty times more.

RETENTION TERM CHART (Example)

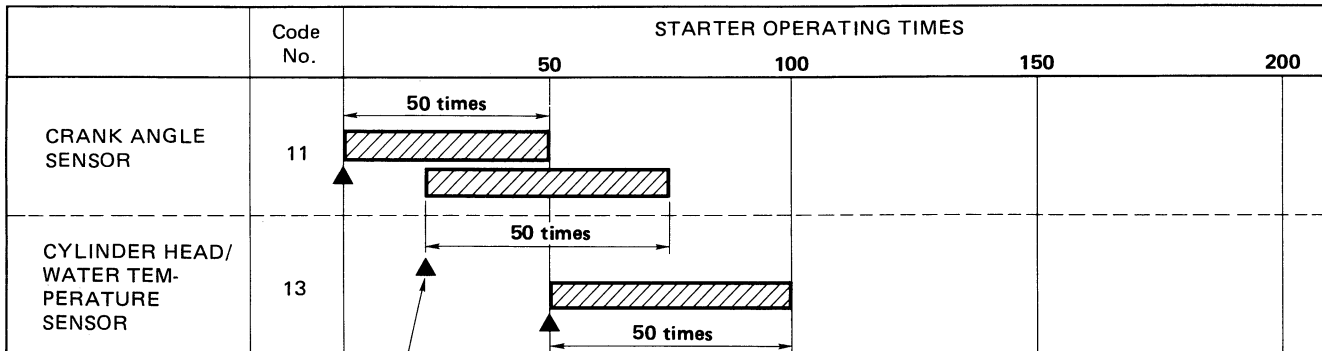

 : Retention term

▲ : Malfunction detecting point

If the same diagnostic item is judged to be malfunctioning before the starter is operated fifty times, it will be stored in E.C.U. memory until the starter is operated fifty times from this point in time.

SEF793D

Mode III — Self-Diagnostic System (Cont'd)
SELF-DIAGNOSTIC PROCEDURE

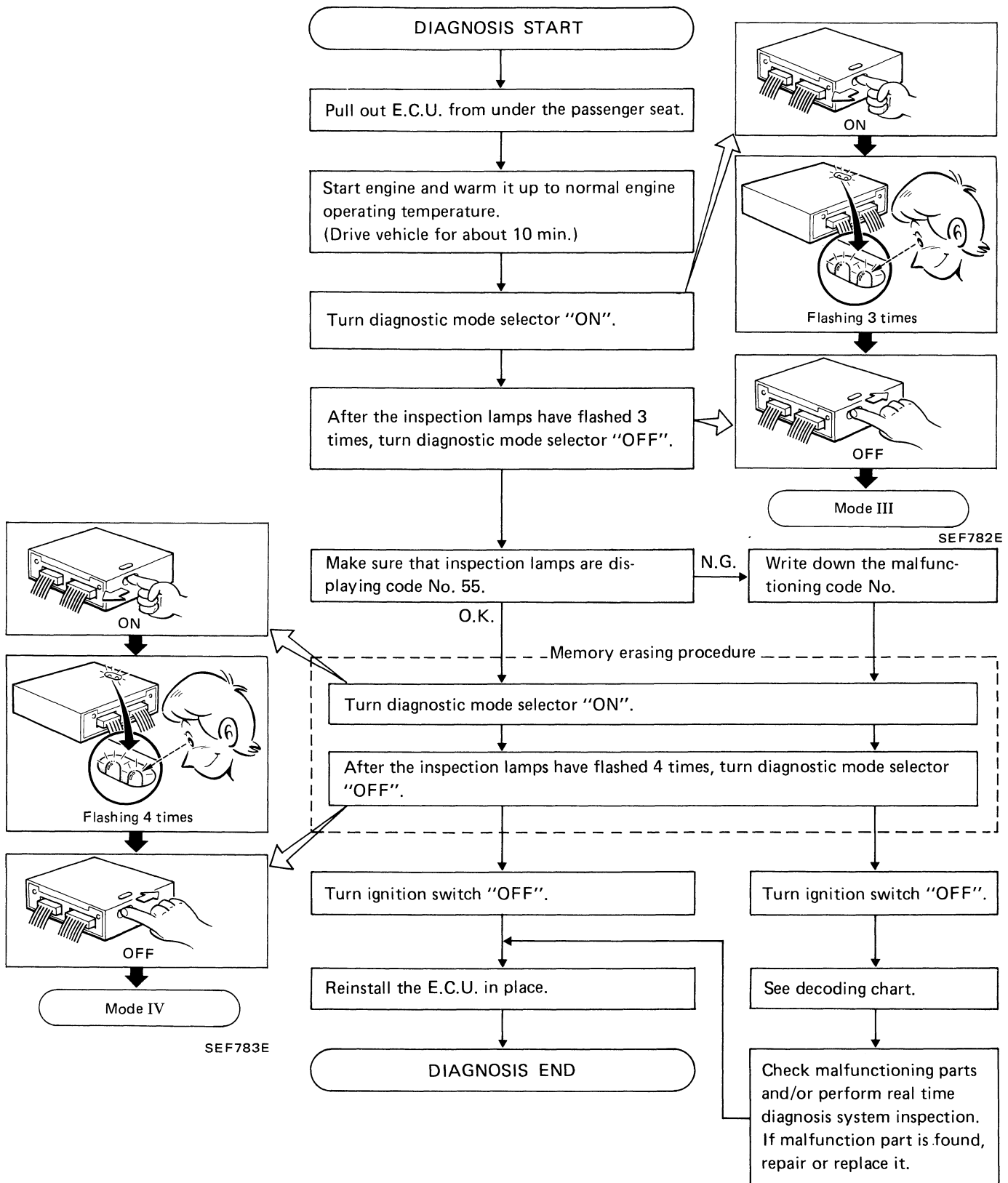

CAUTION:

During displaying code No. in self-diagnosis mode (mode III), if another diagnostic mode should be done, make sure to write down the malfunctioning code No. before turning diagnostic mode selector "ON", or select the diagnostic mode after turning ignition switch "OFF". Otherwise self-diagnosis information stored in E.C.U. memory until now would be lost.

Mode III — Self-Diagnostic System (Cont'd)
DECODING CHART

Display code

Malfunctioning circuit or parts

Control unit shows a malfunction signal when the following conditions are detected.

CRANK ANGLE SENSOR

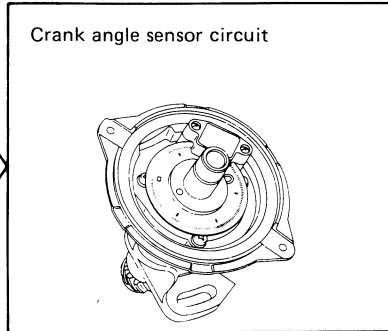
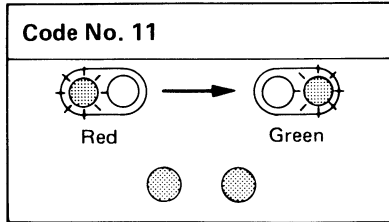

- Either 1° or 180° signal is not entered for the first few seconds during engine cranking.
- Either 1° or 180° signal is not input often enough while the engine speed is higher than the specified rpm.

SYSTEM INSPECTION
See page EF & EC 94/148.

SEF831C

AIR FLOW METER 

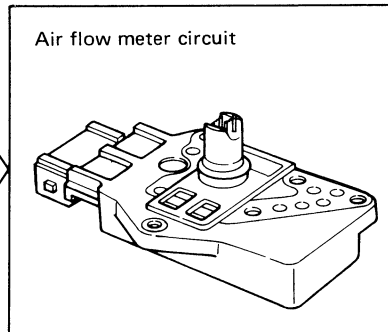
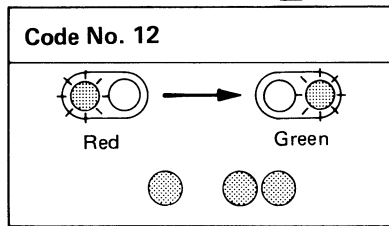

- The air flow meter circuit is open or shorted. (An abnormally high or low voltage is entered.)

SYSTEM INSPECTION
See page EF & EC-96/150.

SEF306D

CYLINDER HEAD/WATER TEMPERATURE SENSOR 

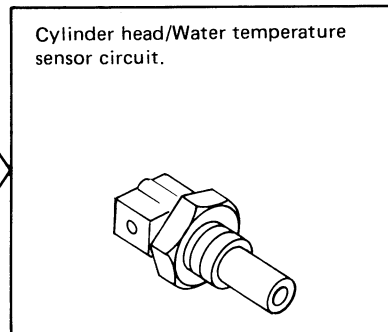
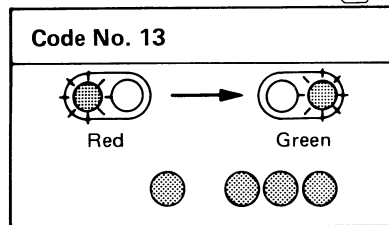

- The cylinder head/Water temperature sensor circuit is open or shorted. (An abnormally high or low output voltage is entered)

SYSTEM INSPECTION
See page EF & EC-98/152.

SEF833C

IGNITION SIGNAL

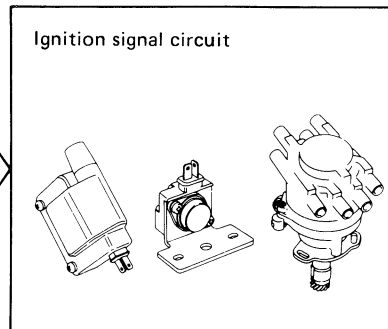
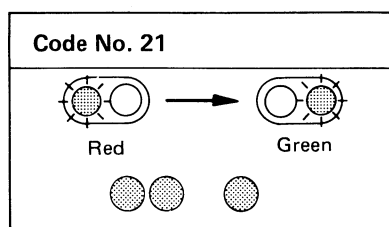

- The ignition signal in primary circuit is not entered during engine cranking or running.

SYSTEM INSPECTION
See page EF & EC-100/154.

SEF834C

Mode III — Self-Diagnostic System (Cont'd)

Display code

Malfunctioning circuit or parts

Control unit shows a malfunction signal when the following conditions are detected

E.C.U. (E.C.C.S. CONTROL UNIT)



Code No. 31

E.C.U. calculation function

- Signal is beyond "normal" range.

SYSTEM INSPECTION
See page EF & EC-102/156.

SEF943F

E.G.R. FUNCTION (California model only)



Code No. 32

E.G.R. function

- E.G.R. valve does not operate. (E.G.R. valve spring does not lift.)

SYSTEM INSPECTION
See page EF & EC-104/158.

SEF238G

EXHAUST GAS SENSOR



Code No. 33

Exhaust gas sensor circuit

- An abnormally high output voltage is entered.

SYSTEM INSPECTION
See page EF & EC-108/162.

SEF309D

Exhaust gas temperature sensor circuit (California model only)



Code No. 35

Exhaust gas temperature sensor circuit

- Signal circuit is open.

SYSTEM INSPECTION
See page EF & EC-110/164.

SEF239G

Mode III — Self-Diagnostic System (Cont'd)

Display code

Malfunctioning circuit or parts

Control unit shows a malfunction signal when the following conditions are detected

THROTTLE SENSOR 

Code No. 43

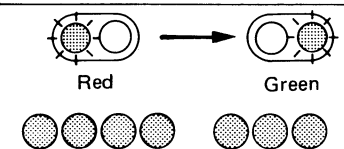
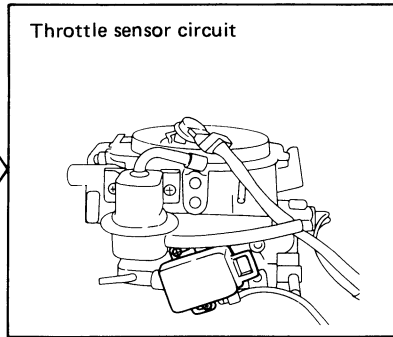
- Throttle sensor circuit is open or short. (Output voltage is too high or too low.)

SYSTEM INSPECTION
See page EF & EC-114/168.

SEF236G

INJECTOR LEAK 
(California model only)

Code No. 45

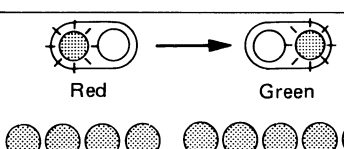
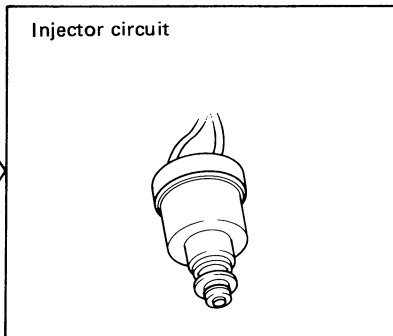
- Leak from the injector.

SYSTEM INSPECTION
See page EF & EC-118/172.

SEF237G

INJECTOR (VG30i model only)

Code No. 51

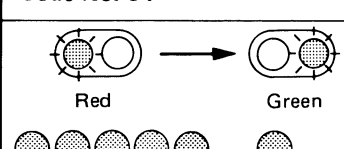
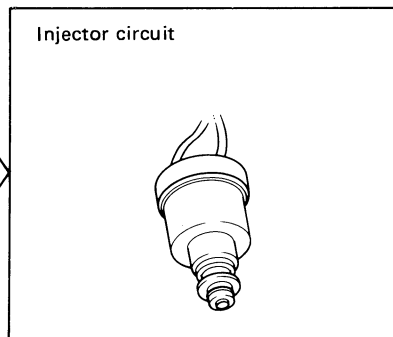



- Either of the two injectors does not work because of an electrical problem.

SYSTEM INSPECTION
See page EF & EC-120.

SEF240G

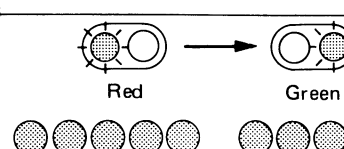
Code No. 55



E.C.C.S. normal operation.

SEF946F

Mode IV — Switches ON/OFF Diagnostic System

In switches ON/OFF diagnosis system, ON/OFF operation of the following switches can be detected continuously.

- Idle switch
- Starter switch
- Vehicle speed sensor (VG30i A/T model only)

(1) Idle switch & Starter switch

The switches ON/OFF status at the point when mode IV is selected is stored in E.C.U. memory. When either switch is turned from "ON" to "OFF" or "OFF" to "ON", the red L.E.D. on E.C.U. alternately comes on and goes off each time switching is detected.

(2) Vehicle Speed Sensor

The switches ON/OFF status at the point when mode IV is selected is stored in E.C.U. memory. When vehicle speed is 20 km/h (12 MPH) or slower, the green L.E.D. on E.C.U. is off. When vehicle speed exceeds 20 km/h (12 MPH), the green L.E.D. on E.C.U. comes "ON".

Mode IV — Switches ON/OFF Diagnostic System (Cont'd)

SELF-DIAGNOSTIC PROCEDURE

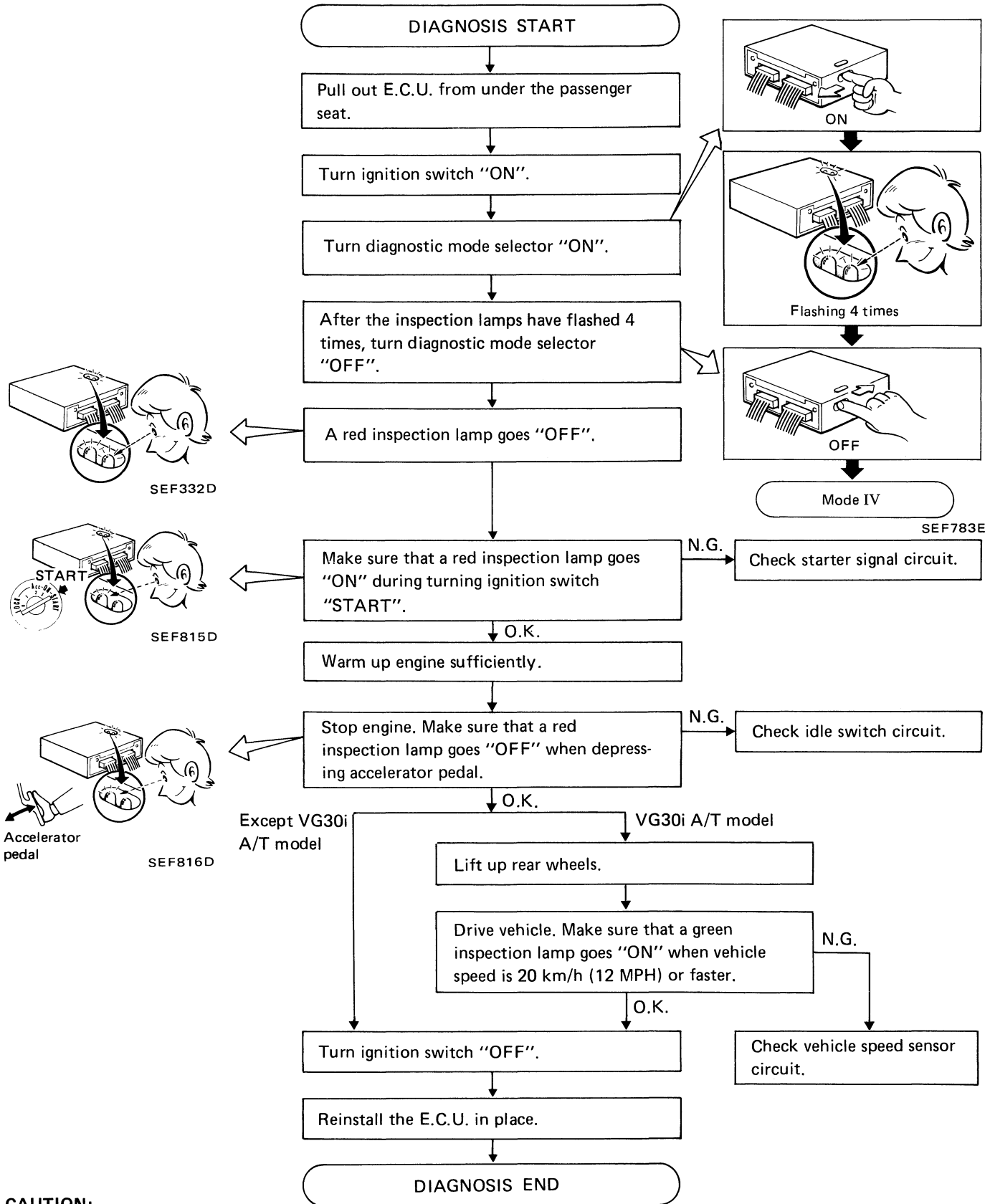

CAUTION:
For safety, do not drive rear wheels at higher speed than required.

Mode V — Real Time Diagnostic System

In real time diagnosis, if any of the following items are judged to be faulty, a malfunction is indicated immediately.

- Crank angle sensor [(120° signal & 1° signal: VG30i model), (180° signal & 1° signal: Z24i model)]
- Ignition signal
- Air flow meter output signal

Consequently, this diagnosis is a very effective measure to diagnose whether the above systems cause the malfunction or not, during driving test. Compared with self-diagnosis, real time diagnosis is very sensitive, and can detect malfunctioning conditions in a moment. Further, items regarded to be malfunctions in this diagnosis are not stored in E.C.U. memory.

SELF-DIAGNOSTIC PROCEDURE

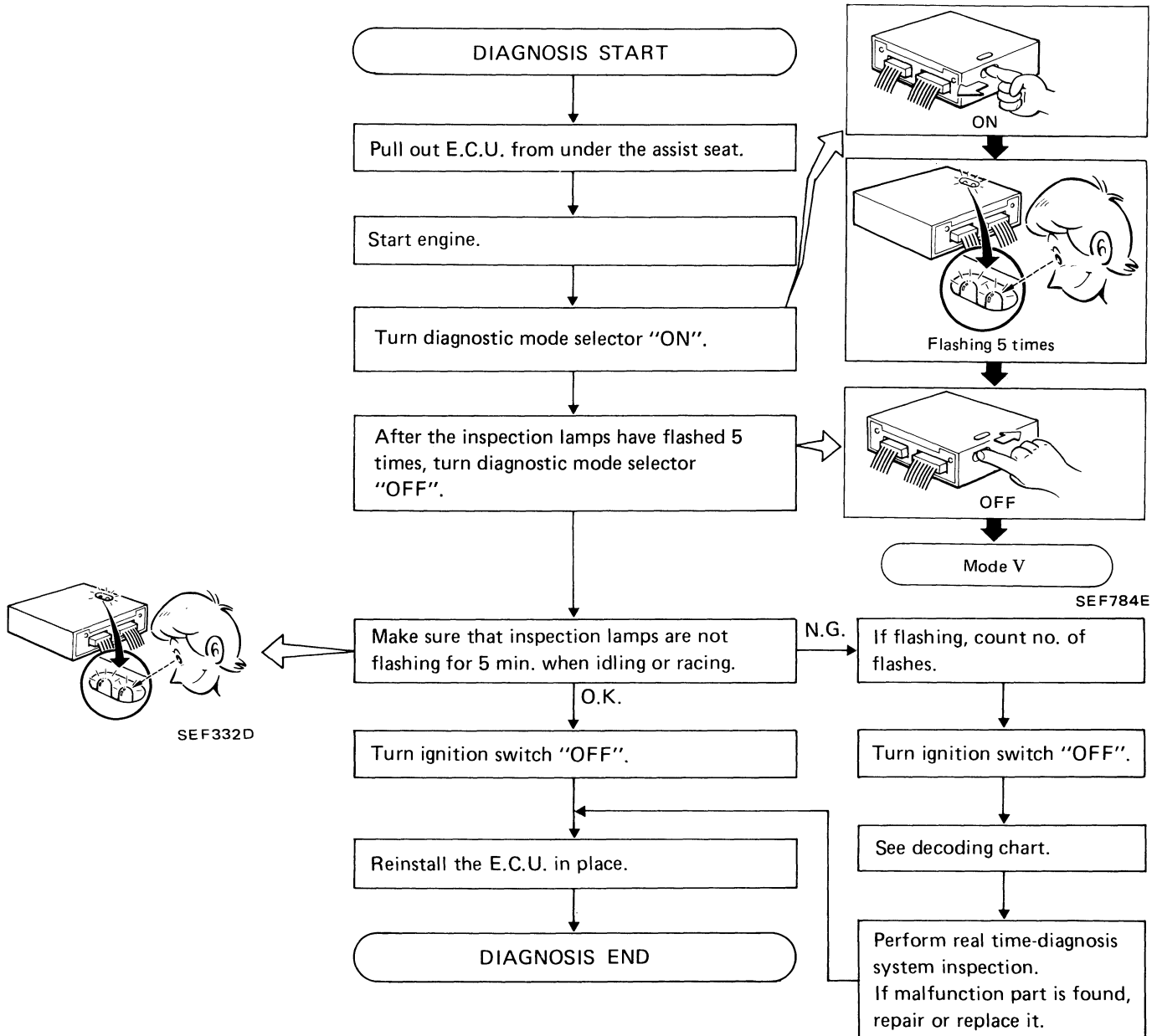

CAUTION:

In real time diagnosis, pay attention to inspection lamp flashing. E.C.U. displays the malfunction code only once, and does not memorize the inspection.

Mode V — Real Time Diagnostic System
(Cont'd)

DECODING CHART

Display presentation

Malfunction circuit or parts

Control unit shows a malfunction signal when the following conditions are detected.

(Compare with Self Diagnosis — Mode III.)

CRANK ANGLE SENSOR

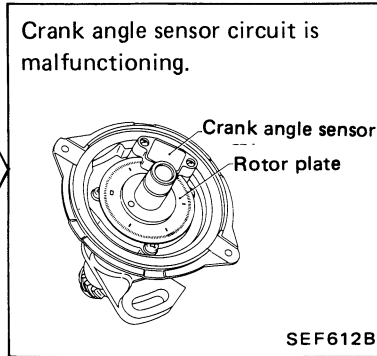
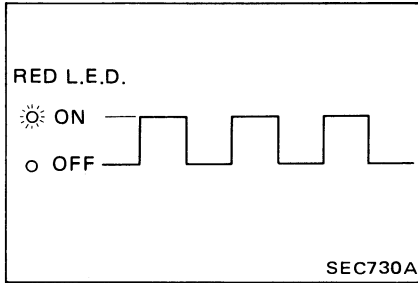

The 1° or 120° (or 180°) signal is momentarily missing, or, multiple, momentary noise signals enter.

REAL TIME DIAGNOSTIC INSPECTION
 See page EF & EC-86/89.

AIR FLOW METER

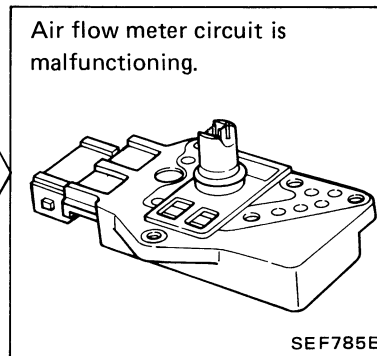
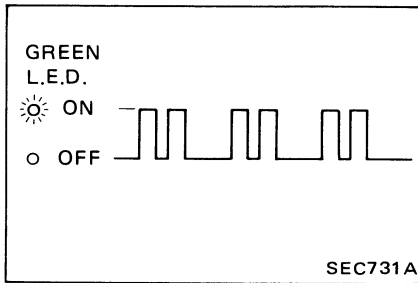

Abnormal, momentary increase in air flow meter output signal.

REAL TIME DIAGNOSTIC INSPECTION
 See page EF & EC-87/90.

IGNITION SIGNAL

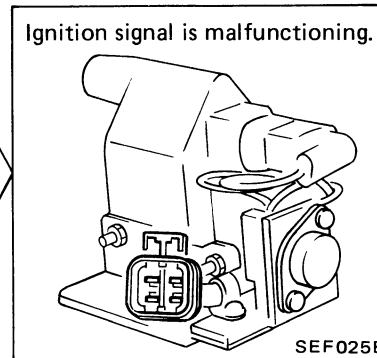
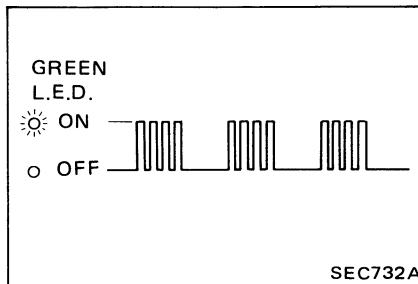

Signal from the primary ignition coil momentarily drops off.

REAL TIME DIAGNOSTIC INSPECTION
 See page EF & EC-88/91.

Mode V — Real Time Diagnostic System
(Cont'd)

REAL TIME DIAGNOSTIC INSPECTION

Crank Angle Sensor

X: Available
—: Not available

Check sequence	Check items	Check conditions	Check parts			If malfunction, perform the following items.
			Middle connector	Sensor & actuator	E.C.U. 20 & 16 pin connector	
1	Tap harness connector or component during real time diagnosis.	During real time diagnosis	X	X	X	Go to check item 2.
2	Check harness continuity at connector.	Engine stopped	X	—	—	Go to check item 3.
3	Disconnect harness connector, and then check dust adhesion to harness connector.	Engine stopped	X	—	X	Clean terminal surface.
4	Check pin terminal bend.	Engine stopped	—	—	X	Take out bend.
5	Reconnect harness connector and then recheck harness continuity at connector.	Engine stopped	X	—	—	Replace terminal.
6	Tap harness connector or component during real time diagnosis.	During real time diagnosis	X	X	X	If malfunction codes are displayed during real time diagnosis, replace terminal.

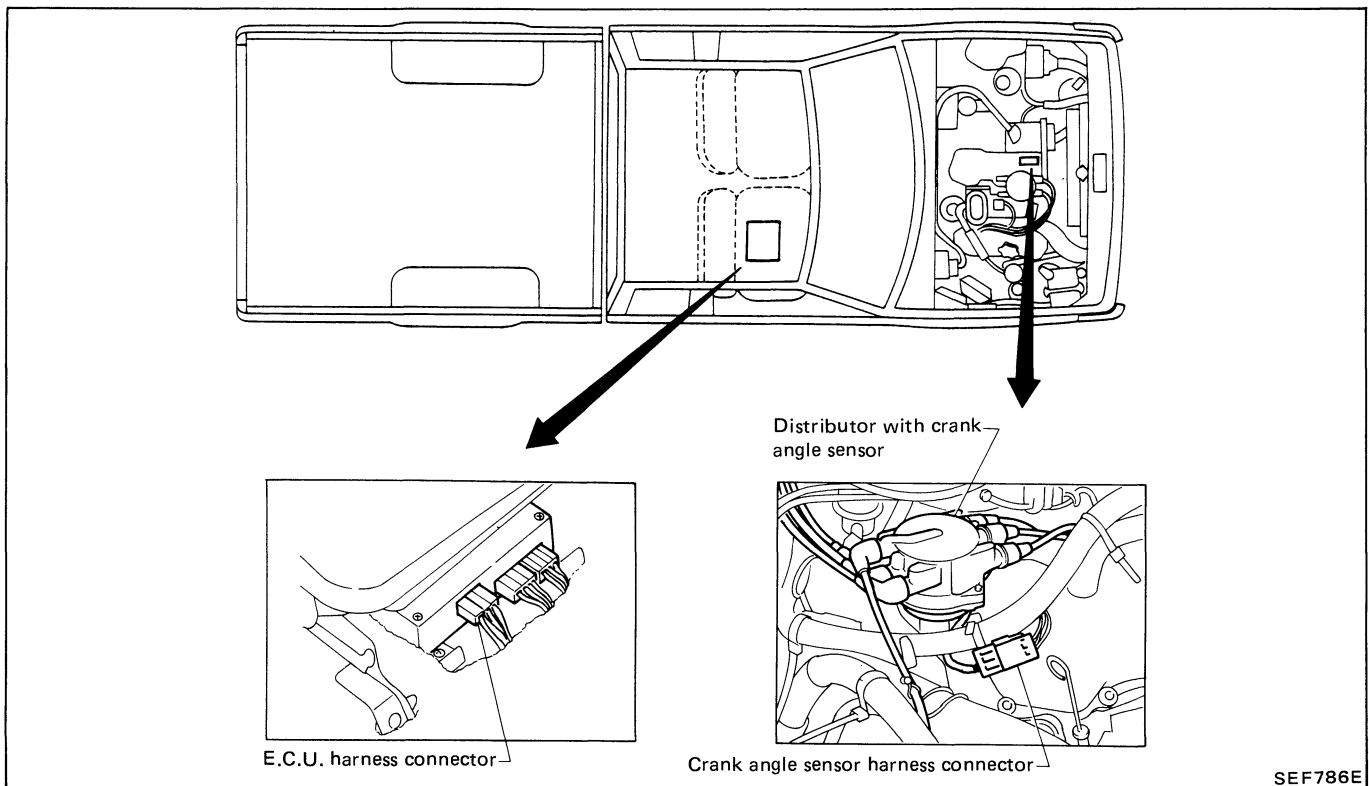

SEF786E

Mode V — Real Time Diagnostic System
(Cont'd)

Air Flow Meter

X: Available
—: Not available

Check sequence	Check items	Check conditions	Check parts			If malfunction, perform the following items.
			Middle connector	Sensor & actuator	E.C.U. 20 & 16 pin connector	
1	Tap harness connector or component during real time diagnosis.	During real time diagnosis	X	X	X	Go to check item 2.
2	Check harness continuity at connector.	Engine stopped	X	—	—	Go to check item 3.
3	Disconnect harness connector, and then check dust adhesion to harness connector.	Engine stopped	X	—	X	Clean terminal surface.
4	Check pin terminal bend.	Engine stopped	—	—	X	Take out bend.
5	Reconnect harness connector and then recheck harness continuity at connector.	Engine stopped	X	—	—	Replace terminal.
6	Tap harness connector or component during real time diagnosis.	During real time diagnosis	X	X	X	If malfunction codes are displayed during real time diagnosis, replace terminal.

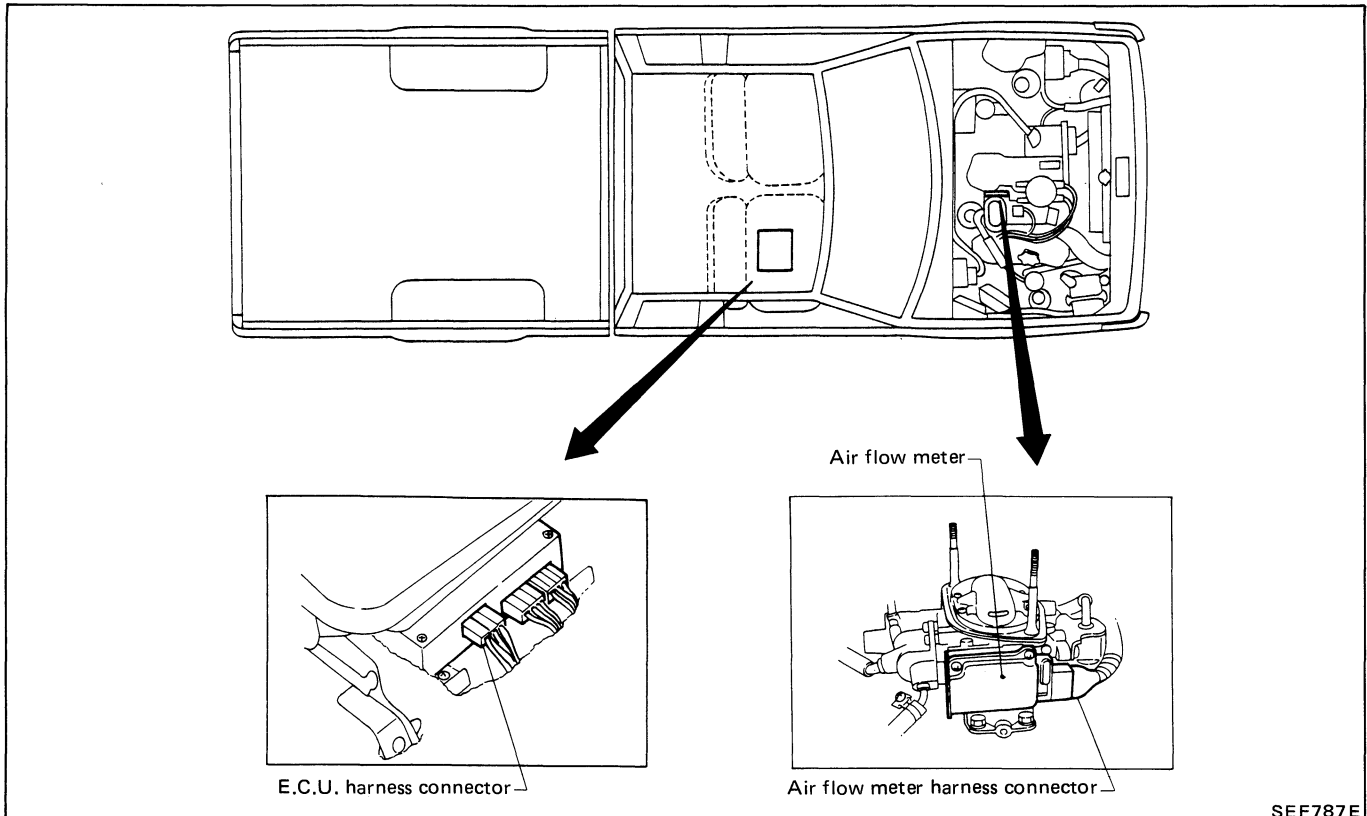

SEF787E

Mode V — Real Time Diagnostic System
(Cont'd)

X: Available
—: Not available

Ignition Signal

Check sequence	Check items	Check conditions	Check parts			If malfunction, perform the following items.
			Middle connector	Sensor & actuator	E.C.U. 20 & 16 pin connector	
1	Tap harness connector or component during real time diagnosis.	During real time diagnosis	X	X	X	Go to check item 2.
2	Check harness continuity at connector.	Engine stopped	X	—	—	Go to check item 3.
3	Disconnect harness connector, and then check dust adhesion to harness connector.	Engine stopped	X	—	X	Clean terminal surface.
4	Check pin terminal bend.	Engine stopped	—	—	X	Take out bend.
5	Reconnect harness connector and then recheck harness continuity at connector.	Engine stopped	X	—	—	Replace terminal.
6	Tap harness connector or component during real time diagnosis.	During real time diagnosis	X	X	X	If malfunction codes are displayed during real time diagnosis, replace terminal.

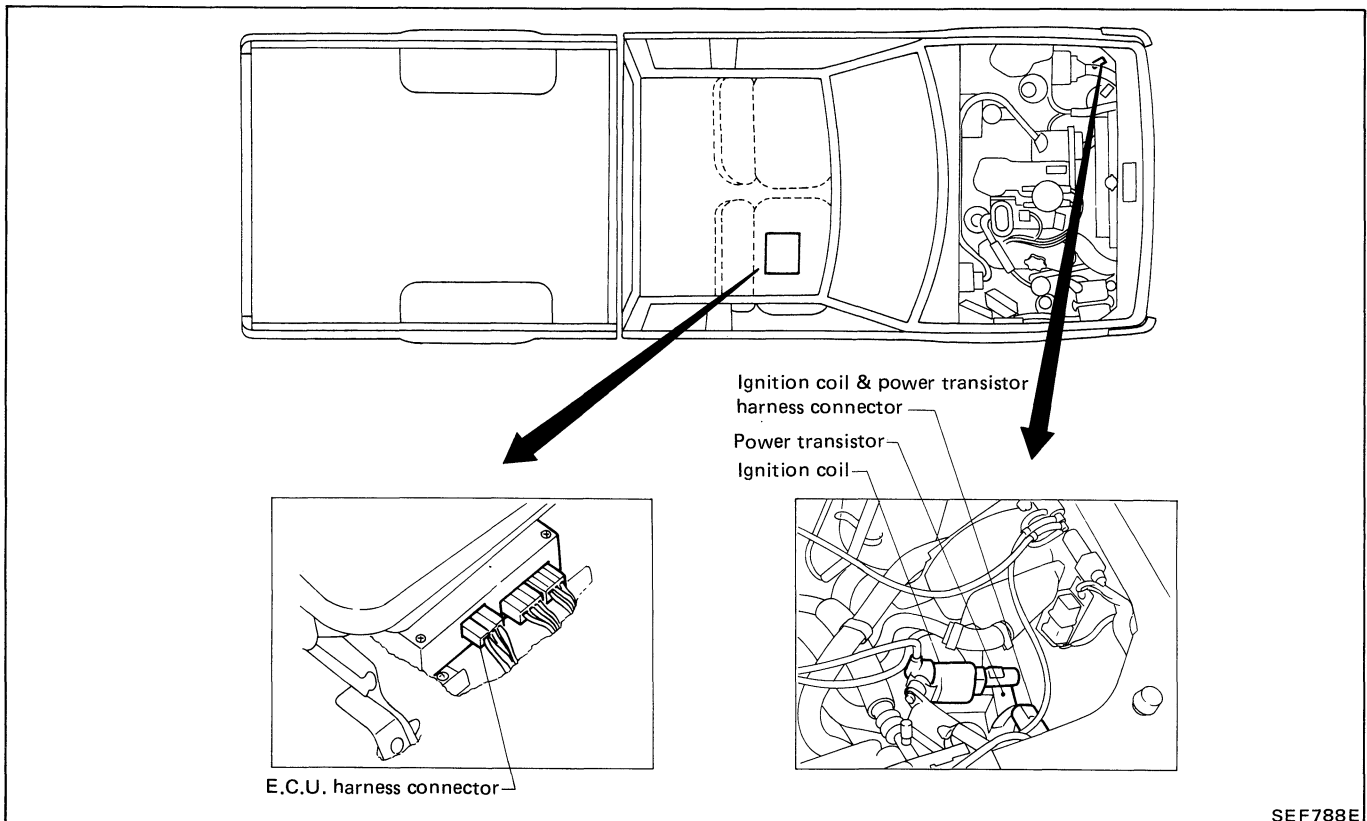

SEF788E

Mode V — Real Time Diagnostic System
(Cont'd)

REAL TIME DIAGNOSTIC INSPECTION

Crank Angle Sensor

X: Available
—: Not available

Check sequence	Check items	Check conditions	Check parts			If malfunction, perform the following items.
			Middle connector	Sensor & actuator	E.C.U. 20 & 16 pin connector	
1	Tap harness connector or component during real time diagnosis.	During real time diagnosis	X	X	X	Go to check item 2.
2	Check harness continuity at connector.	Engine stopped	X	—	—	Go to check item 3.
3	Disconnect harness connector, and then check dust adhesion to harness connector.	Engine stopped	X	—	X	Clean terminal surface.
4	Check pin terminal bend.	Engine stopped	—	—	X	Take out bend.
5	Reconnect harness connector and then recheck harness continuity at connector.	Engine stopped	X	—	—	Replace terminal.
6	Tap harness connector or component during real time diagnosis.	During real time diagnosis	X	X	X	If malfunction codes are displayed during real time diagnosis, replace terminal.

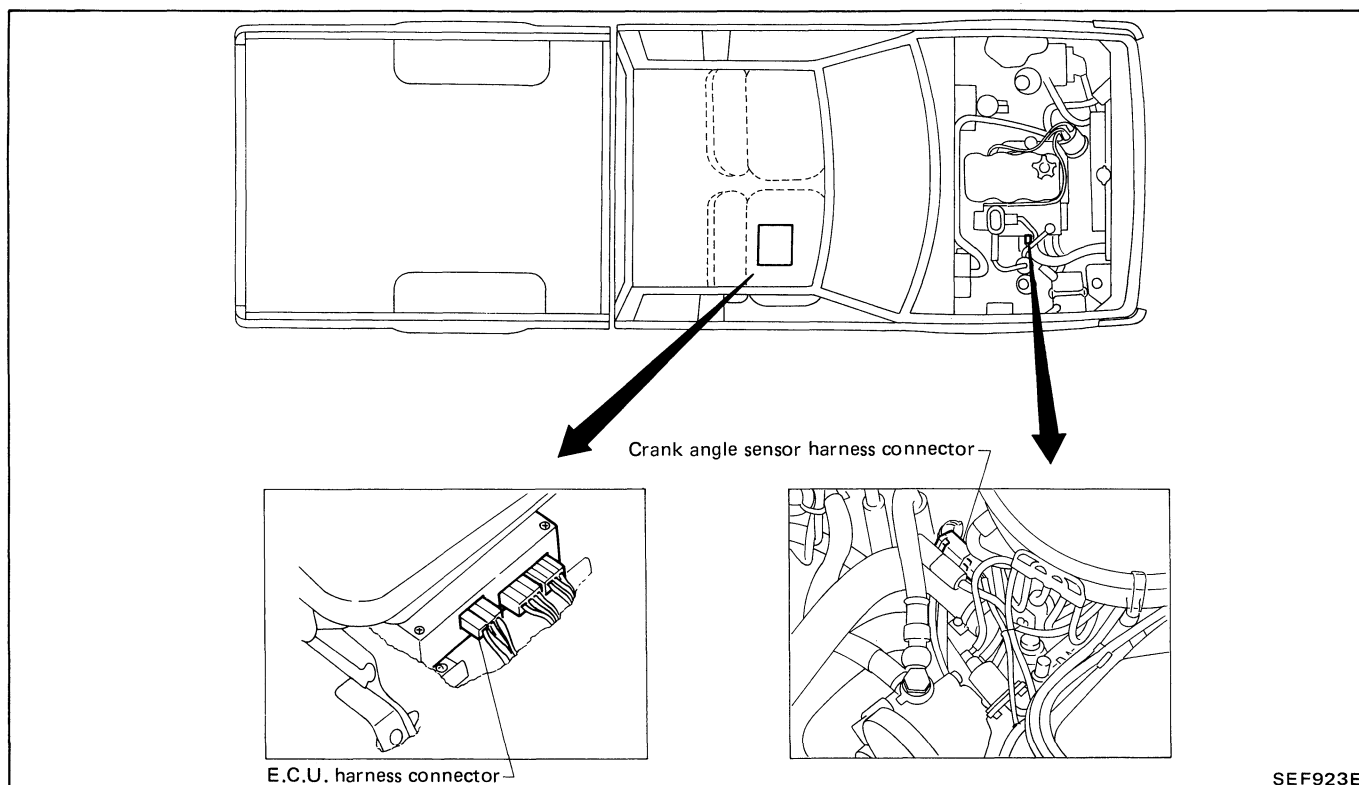

SEF923E

Mode V — Real Time Diagnostic System
(Cont'd)

Air Flow Meter

X: Available
—: Not available

Check sequence	Check items	Check conditions	Check parts			If malfunction, perform the following items.
			Middle connector	Sensor & actuator	E.C.U. 20 & 16 pin connector	
1	Tap harness connector or component during real time diagnosis.	During real time diagnosis	X	X	X	Go to check item 2.
2	Check harness continuity at connector.	Engine stopped	X	—	—	Go to check item 3.
3	Disconnect harness connector, and then check dust adhesion to harness connector.	Engine stopped	X	—	X	Clean terminal surface.
4	Check pin terminal bend.	Engine stopped	—	—	X	Take out bend.
5	Reconnect harness connector and then recheck harness continuity at connector.	Engine stopped	X	—	—	Replace terminal.
6	Tap harness connector or component during real time diagnosis.	During real time diagnosis	X	X	X	If malfunction codes are displayed during real time diagnosis, replace terminal.

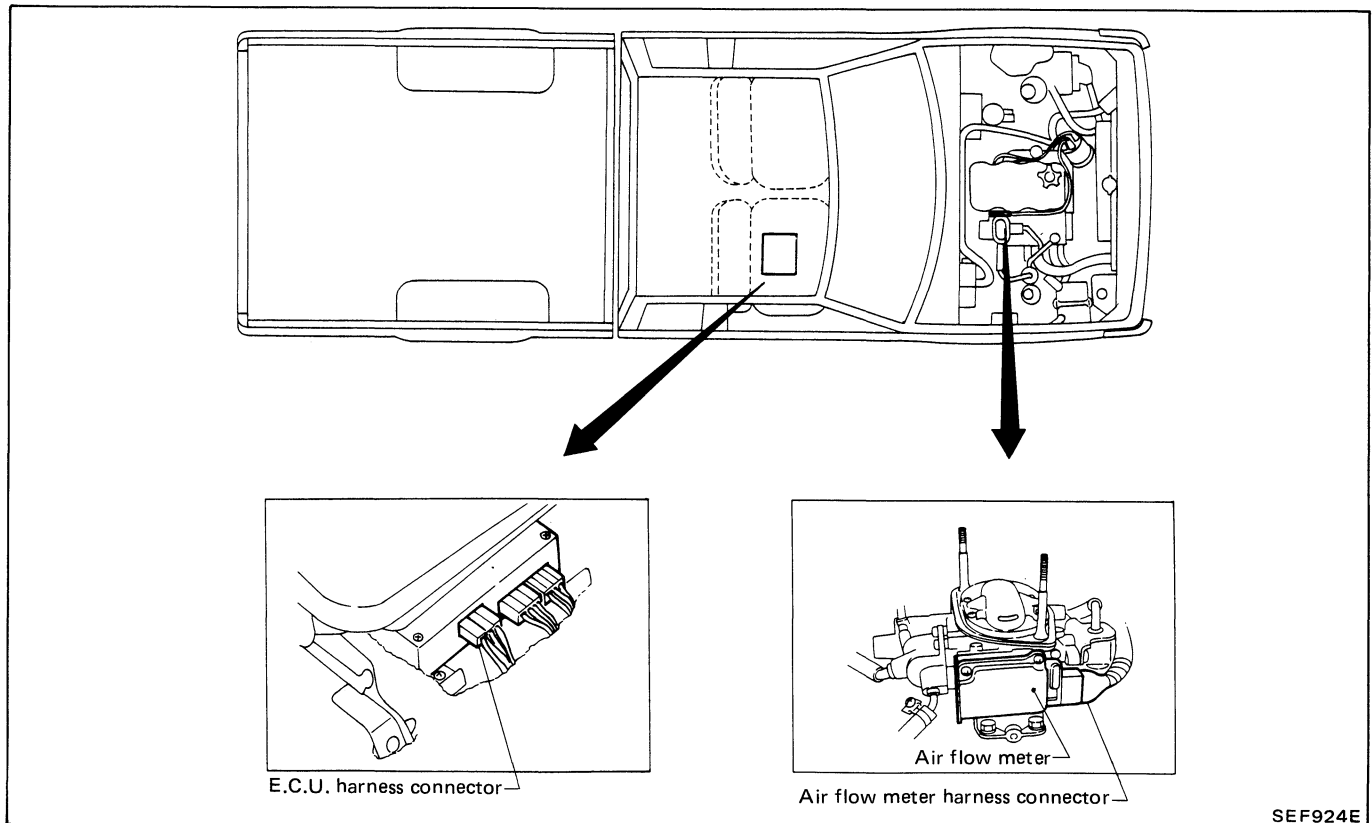

SEF924E

Mode V — Real Time Diagnostic System
(Cont'd)

X: Available
—: Not available

Ignition Signal

Check sequence	Check items	Check conditions	Check parts			If malfunction, perform the following items.
			Middle connector	Sensor & actuator	E.C.U. 20 & 16 pin connector	
1	Tap harness connector or component during real time diagnosis.	During real time diagnosis	X	X	X	Go to check item 2.
2	Check harness continuity at connector.	Engine stopped	X	—	—	Go to check item 3.
3	Disconnect harness connector, and then check dust adhesion to harness connector.	Engine stopped	X	—	X	Clean terminal surface.
4	Check pin terminal bend.	Engine stopped	—	—	X	Take out bend.
5	Reconnect harness connector and then recheck harness continuity at connector.	Engine stopped	X	—	—	Replace terminal.
6	Tap harness connector or component during real time diagnosis.	During real time diagnosis	X	X	X	If malfunction codes are displayed during real time diagnosis, replace terminal.

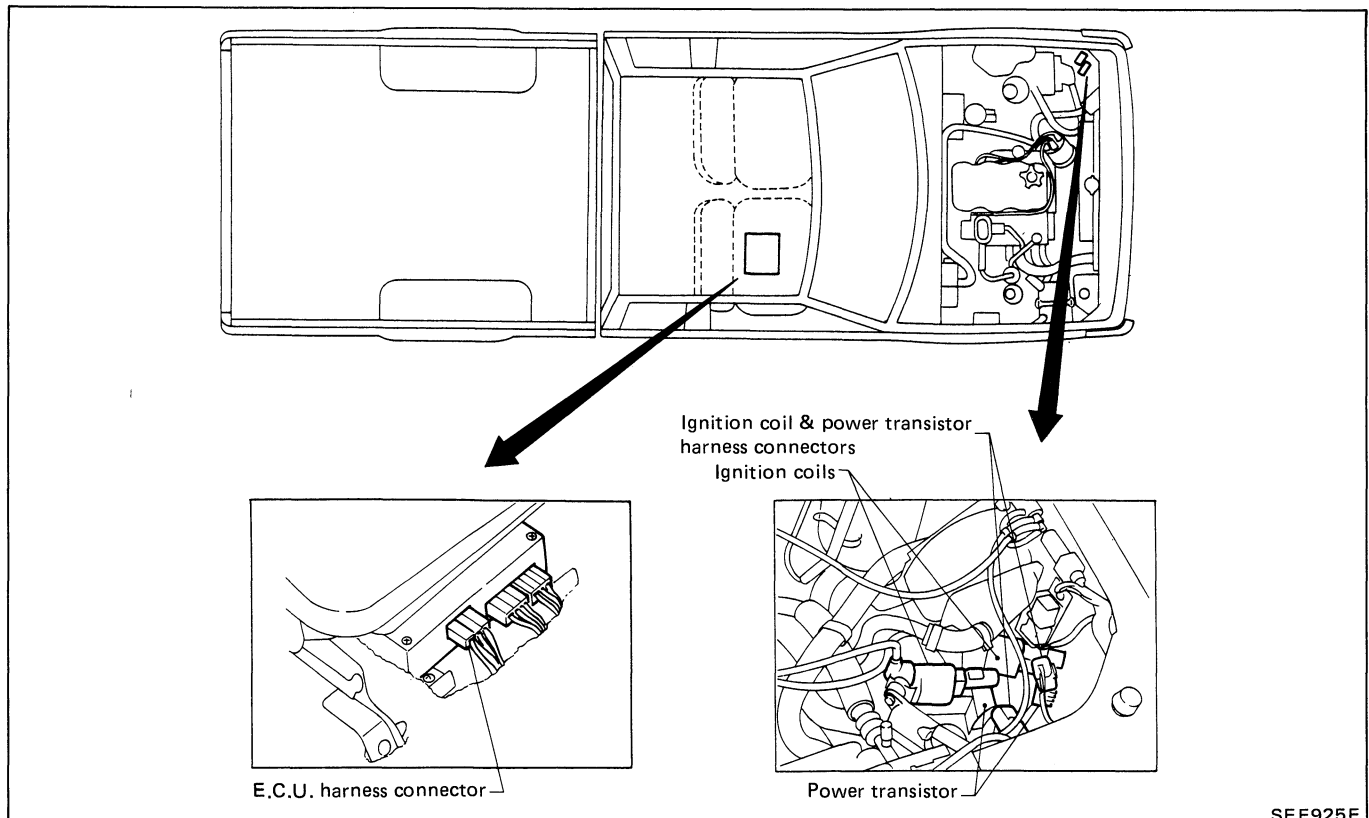

SEF925E

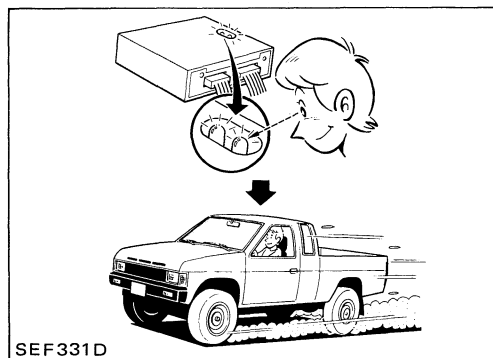
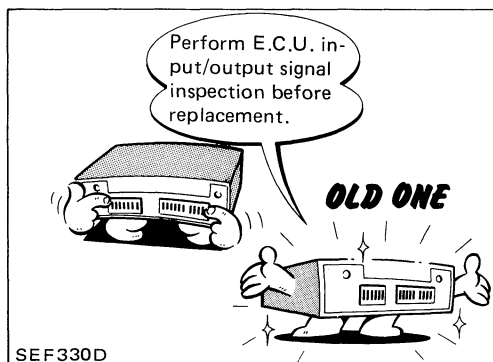
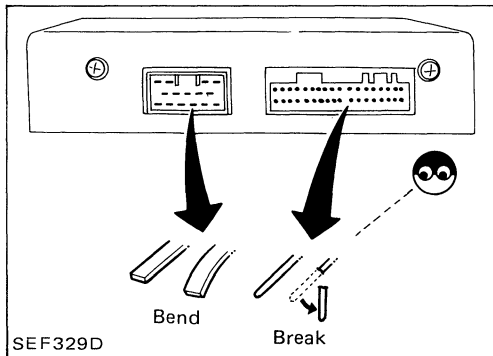
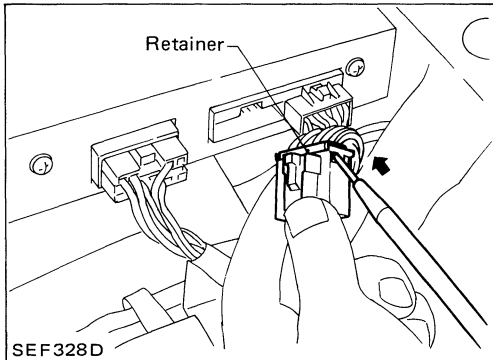
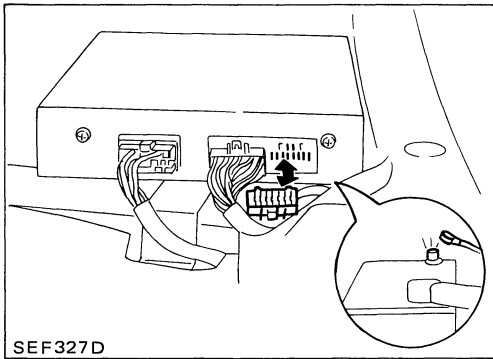

CAUTION:

1. Before connecting or disconnecting E.C.U. harness connector to or from any E.C.U., be sure to turn the ignition switch to the "OFF" position and disconnect the negative battery terminal in order not to damage E.C.U. as battery voltage is applied to E.C.U. even if ignition switch is turned off. Otherwise, there may be damage to the E.C.U.

2. When performing E.C.U. input/output signal inspection, remove pin terminal retainer from 20 and 16 pin connector to make it easier to insert tester probe into connector.

3. When connecting pin connectors into E.C.U. or disconnecting them from E.C.U., take care not to damage pin terminal of E.C.U. (Bend or break).

4. Make sure that there are not any bends or breaks on E.C.U. pin terminal, when connecting pin connectors into E.C.U.

5. Before replacing E.C.U., perform E.C.U. input/output signal inspection and make sure whether E.C.U. functions properly or not. (See page EF & EC-200.)

6. After performing this "ELECTRONIC CONTROL SYSTEM INSPECTION", perform E.C.C.S. self-diagnosis and driving test.

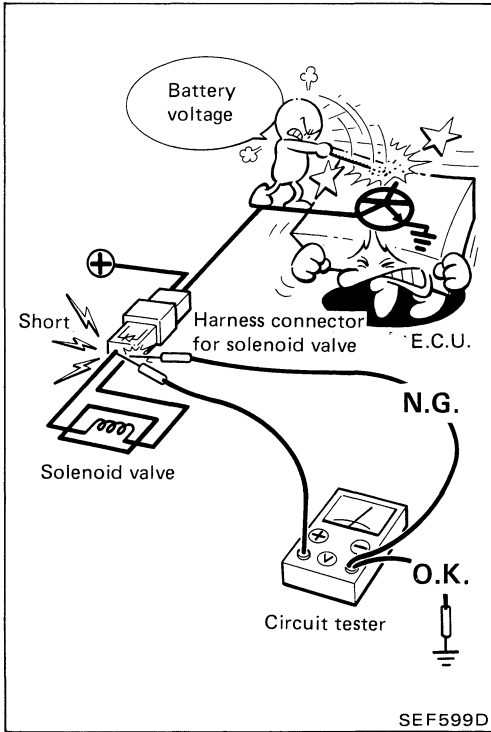

7. When measuring supply voltage of E.C.U. controlled components with a circuit tester, separate one tester probe from the other.

If the two tester probes accidentally make contact with each other during measurement, the circuit will be shorted, resulting in damage to the power transistor of the control unit.

8. Keys to symbols



: Check after disconnecting the connector to be measured.



: Check after connecting the connector to be measured.

9. When measuring voltage or resistance at connector with tester probes, there are two methods of measurement; one is done from terminal side and the other from harness side. Before measuring, confirm symbol mark again.



: Inspection should be done from harness side.



: Inspection should be done from terminal side.

Refer to GI section.

10. As for continuity check of joint connector, refer to EL section.

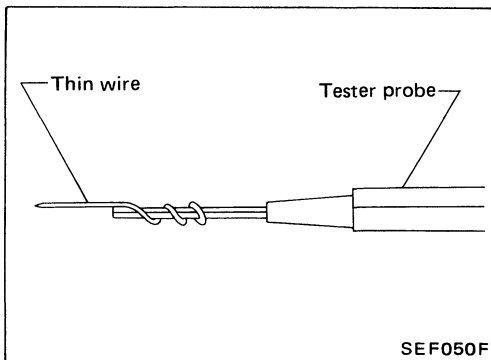

11. Improve tester probe as shown to perform test easily.

12. For the first trouble-shooting procedure, perform POWER SOURCE & GROUND CIRCUIT FOR E.C.U. check.

CRANK ANGLE SENSOR (Code No. 11)

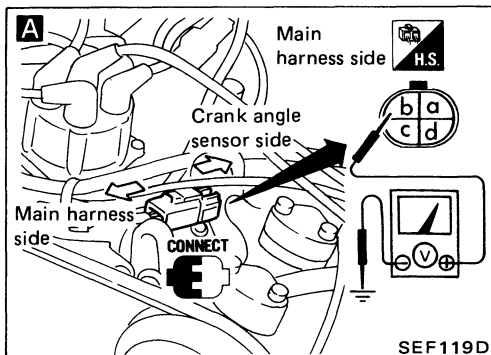
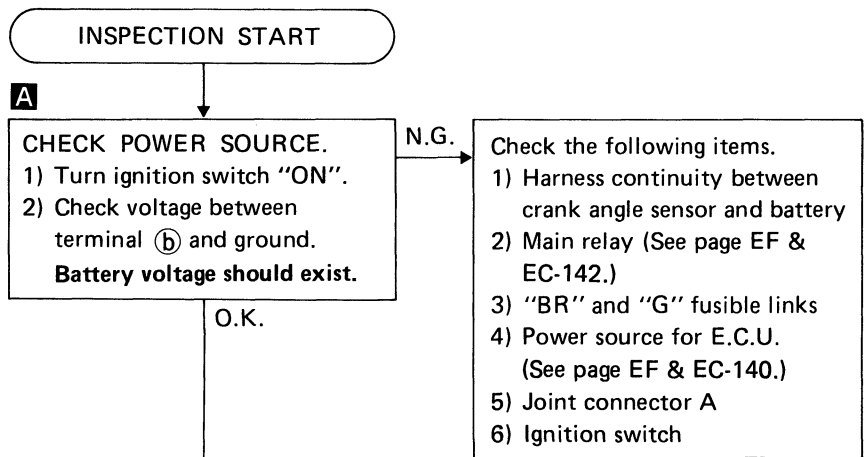
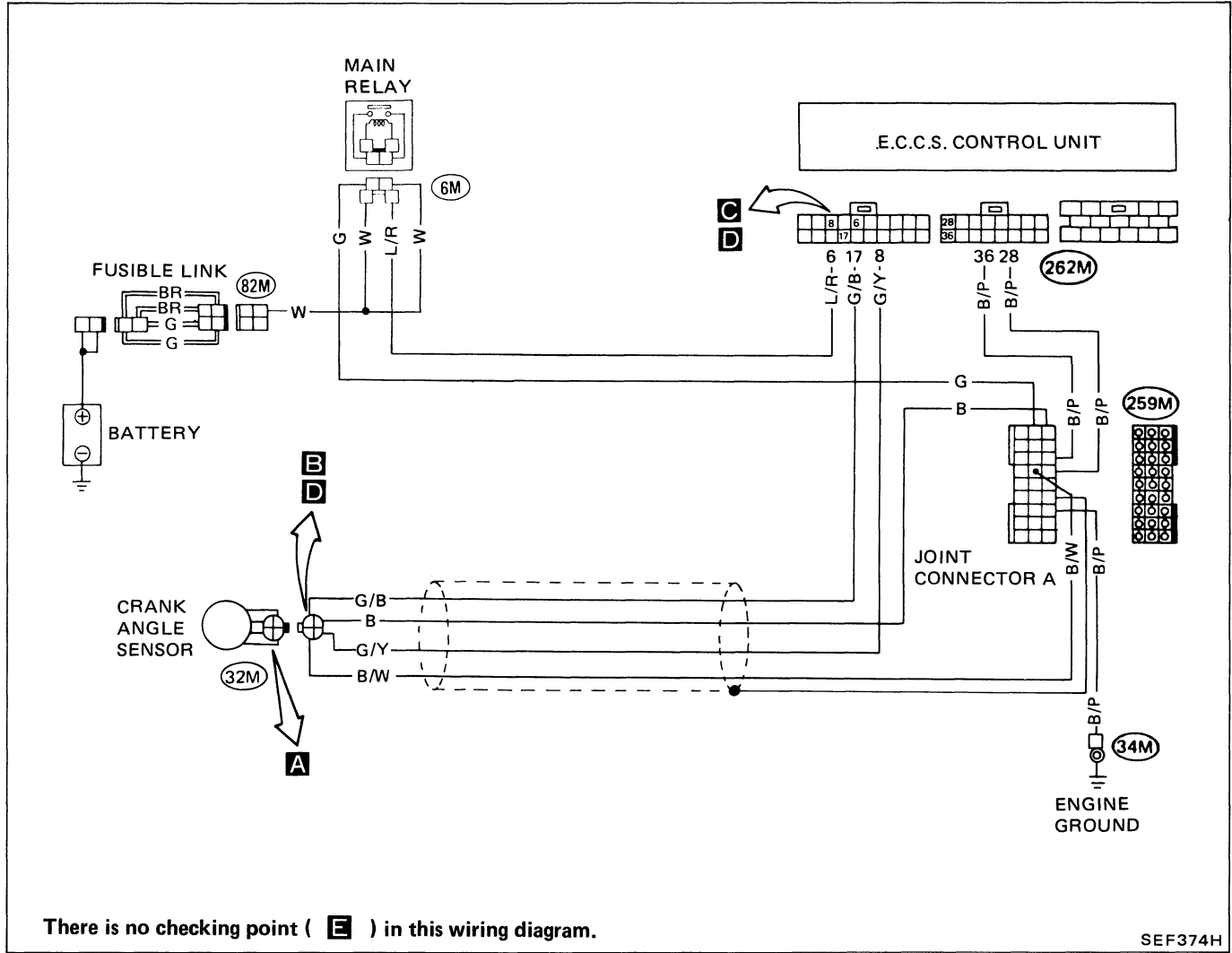

CRANK ANGLE SENSOR (Code No. 11)

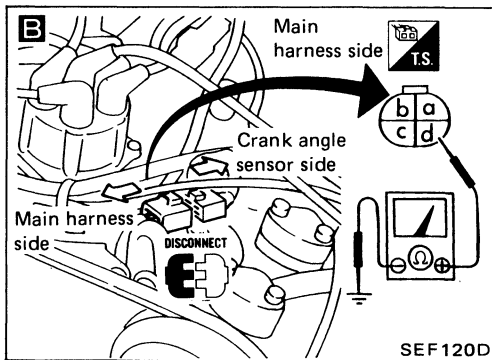

B

CHECK GROUND CIRCUIT.
 1) Turn ignition switch "OFF".
 2) Disconnect crank angle sensor harness connector.
 3) Check resistance between terminal **d** and ground.
Resistance:
Approximately 0Ω

N.G. → Check the following items.
 1) Harness continuity between crank angle sensor and ground
 2) Joint connector A
 3) E.C.U. ground circuit (See page EF & EC-140.)

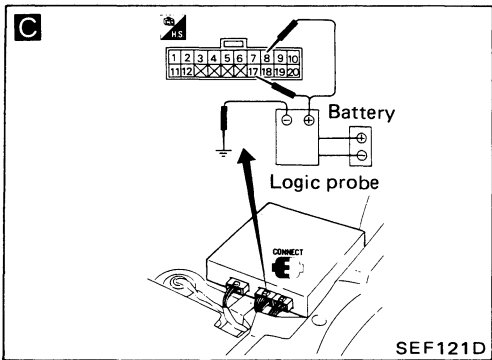

C

CHECK E.C.U. INPUT SIGNALS.
 1) Remove assist side seat.
 2) Reconnect crank angle sensor harness connector.
 3) Start engine.
 4) Check that pulse signals exist in E.C.U. terminals **8** and **17** with logic probe.
Pulse signals should exist.
8 : 1° signal
17 : 120° signals

N.G. → Check the following items.
 1) Harness continuity between crank angle sensor and E.C.U.
D • Stop engine.
 • Disconnect crank angle sensor harness connector.
 • Disconnect E.C.U. 20-pin connector from E.C.U.
 1° signal circuit
 Continuity between **c** and **8**
 120° signal circuit
 Continuity between **a** and **17**
Resistance:
Approximately 0Ω

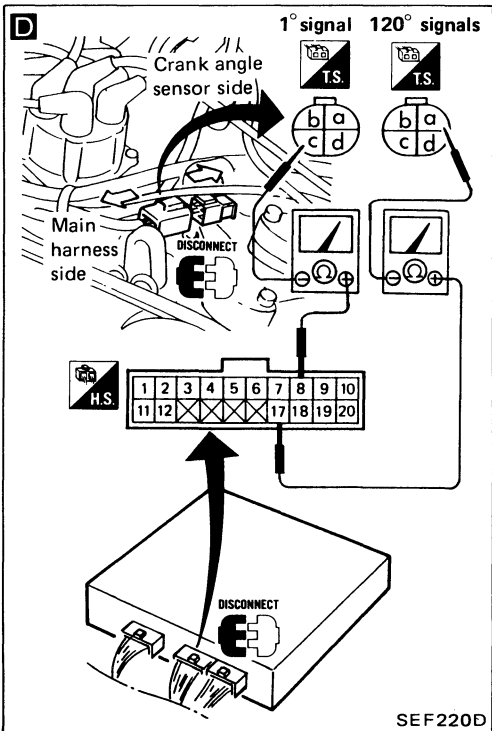

O.K. → Stop engine and check interference between crank angle sensor harness and high-tension cable.

N.G. → Separate them.

E

Visually check rotor plate for damage or dust.

N.G. → Clean or replace crank angle sensor.

O.K. → Reinstall any part removed.

Erase the self-diagnosis memory.

Perform driving test and then perform self-diagnosis (Mode III again).

N.G. → 1) Perform E.C.U. input/output signal inspection test.
 2) If N.G., recheck the E.C.U. pin terminals damage or the connection of E.C.U. harness connector.

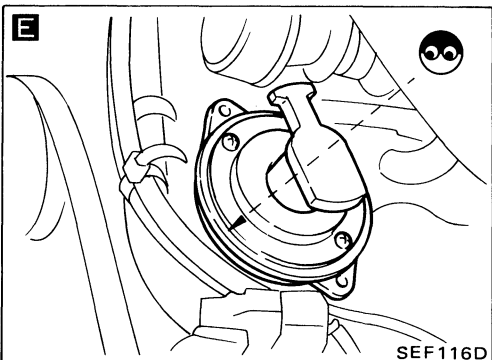

O.K. → INSPECTION END

AIR FLOW METER (Code No. 12)  (CHECK ENGINE LIGHT ITEM)

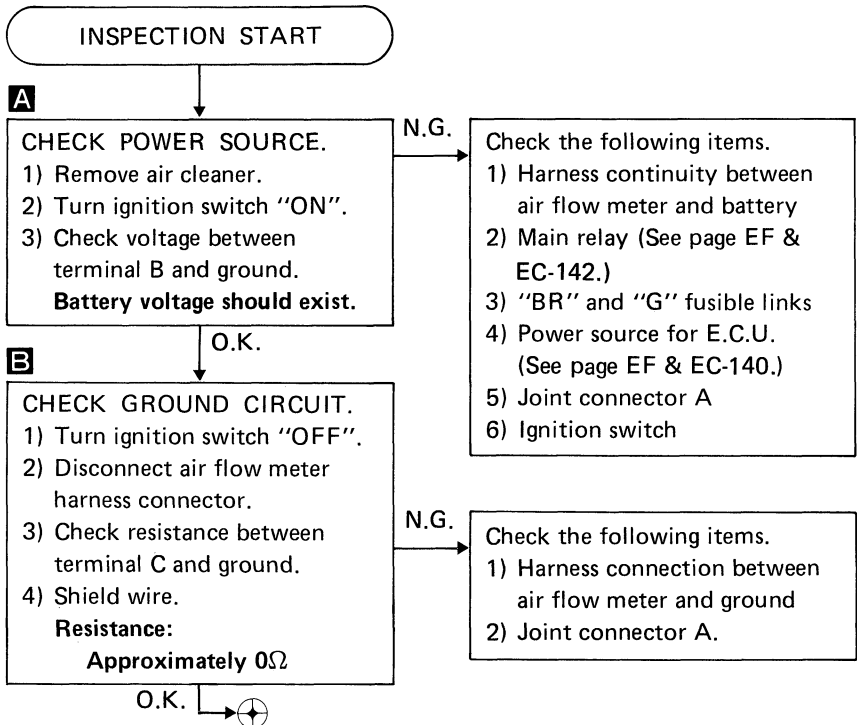
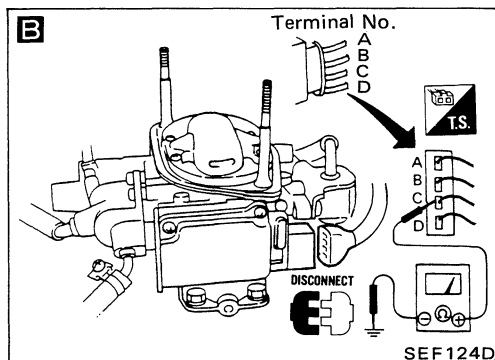
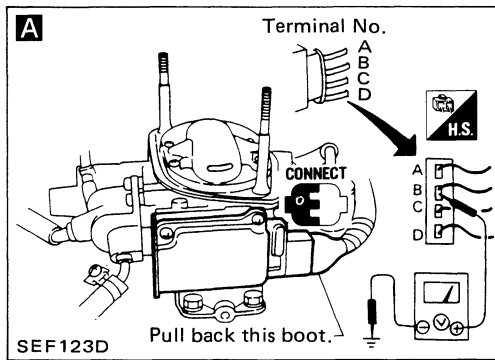
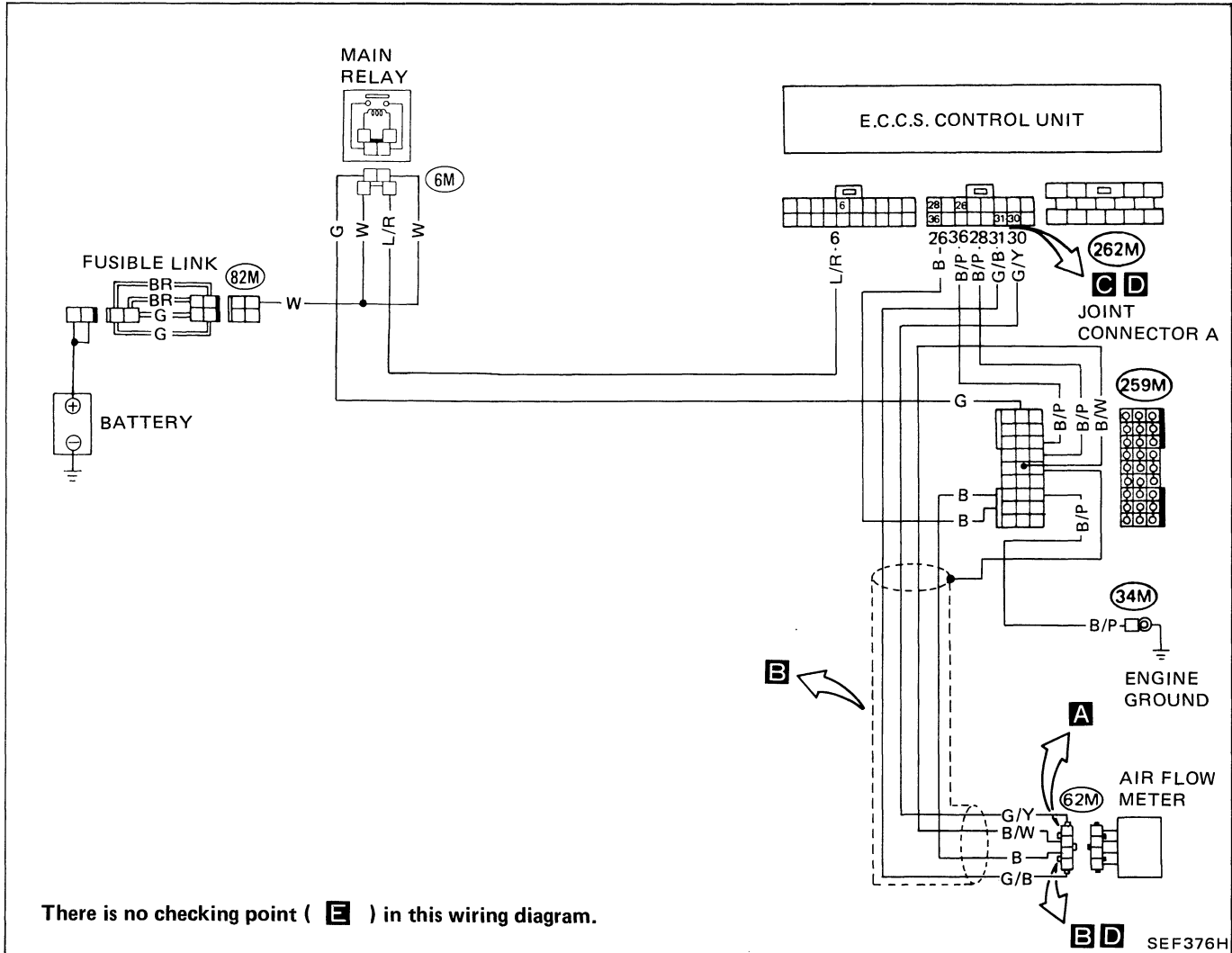

AIR FLOW METER (Code No. 12) CHECK (CHECK ENGINE LIGHT ITEM)

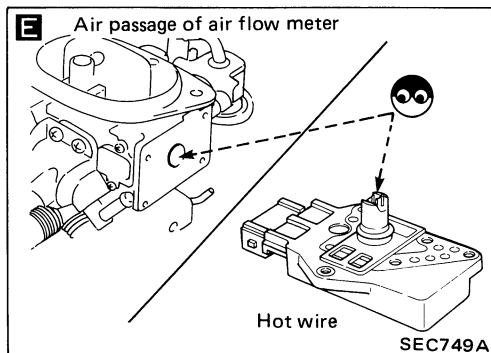
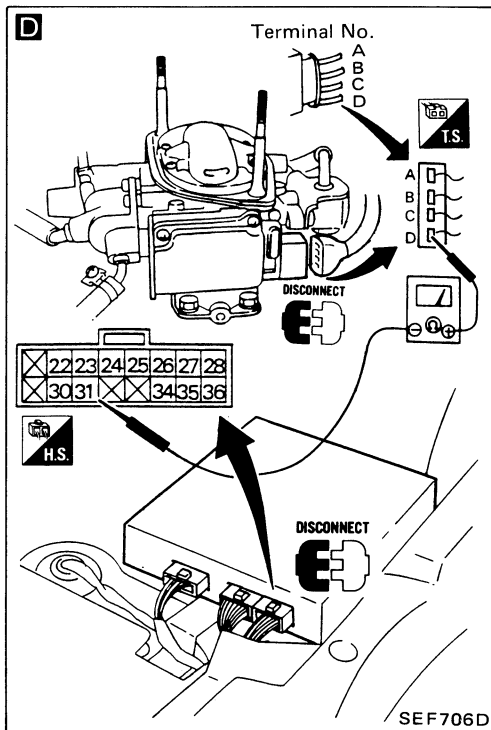
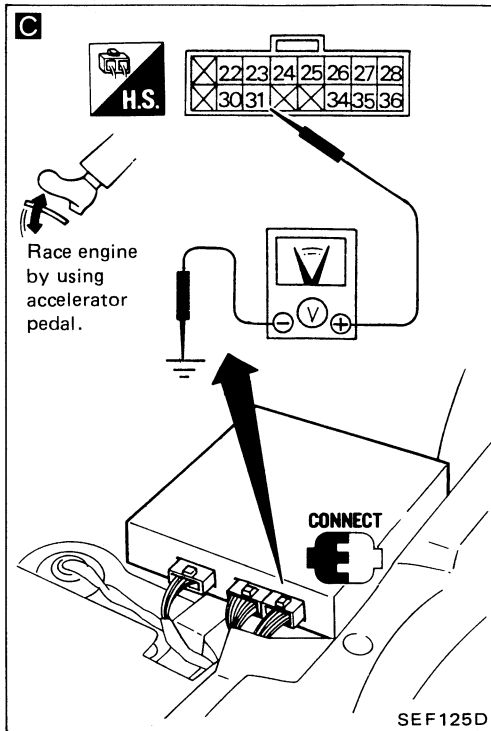

C

CHECK E.C.U. INPUT SIGNAL.

- 1) Remove assist side seat.
- 2) Reconnect air flow meter harness connector.
- 3) Start engine and warm it up sufficiently.
- 4) Make sure that voltage between E.C.U. terminal ① and ground changes under the following conditions.

Output voltage should change.

- When racing engine with accelerator pedal
Approximately 0 - 5V
- Idling condition
1 - 2V

N.G. → **D**

D

Check harness continuity between E.C.U. and air flow meter.

- Stop engine.
- Disconnect air flow meter harness connector.
- Disconnect E.C.U. 16-pin harness connector.
- Check resistance between terminal D and E.C.U. terminal ③1.

Resistance:
Approximately 0Ω
If O.K., replace air flow meter.

O.K. → **E**

E

CHECK AIR PASSAGE OF AIR FLOW METER

- 1) Remove air flow meter from injector body.
- 2) Make sure that air passage of air flow meter in injection body or hot wire is not wet with fuel.

Wet → Check that both injectors are installed properly, following the procedure as shown on page EF & EC-222. (Step 11)
If N.G., repair or replace malfunctioning part.

Not wet → Reinstall any part removed.

Erase the self-diagnosis memory.

Perform driving test and then perform self-diagnosis (Mode III) again.

N.G. → 1) Perform E.C.U. input/output signal inspection test.
2) If N.G., recheck the E.C.U. pin terminals damage or the connection of E.C.U. harness connector.

O.K. → **INSPECTION END**

CYLINDER HEAD TEMPERATURE SENSOR (Code No. 13)  (CHECK ENGINE LIGHT ITEM)

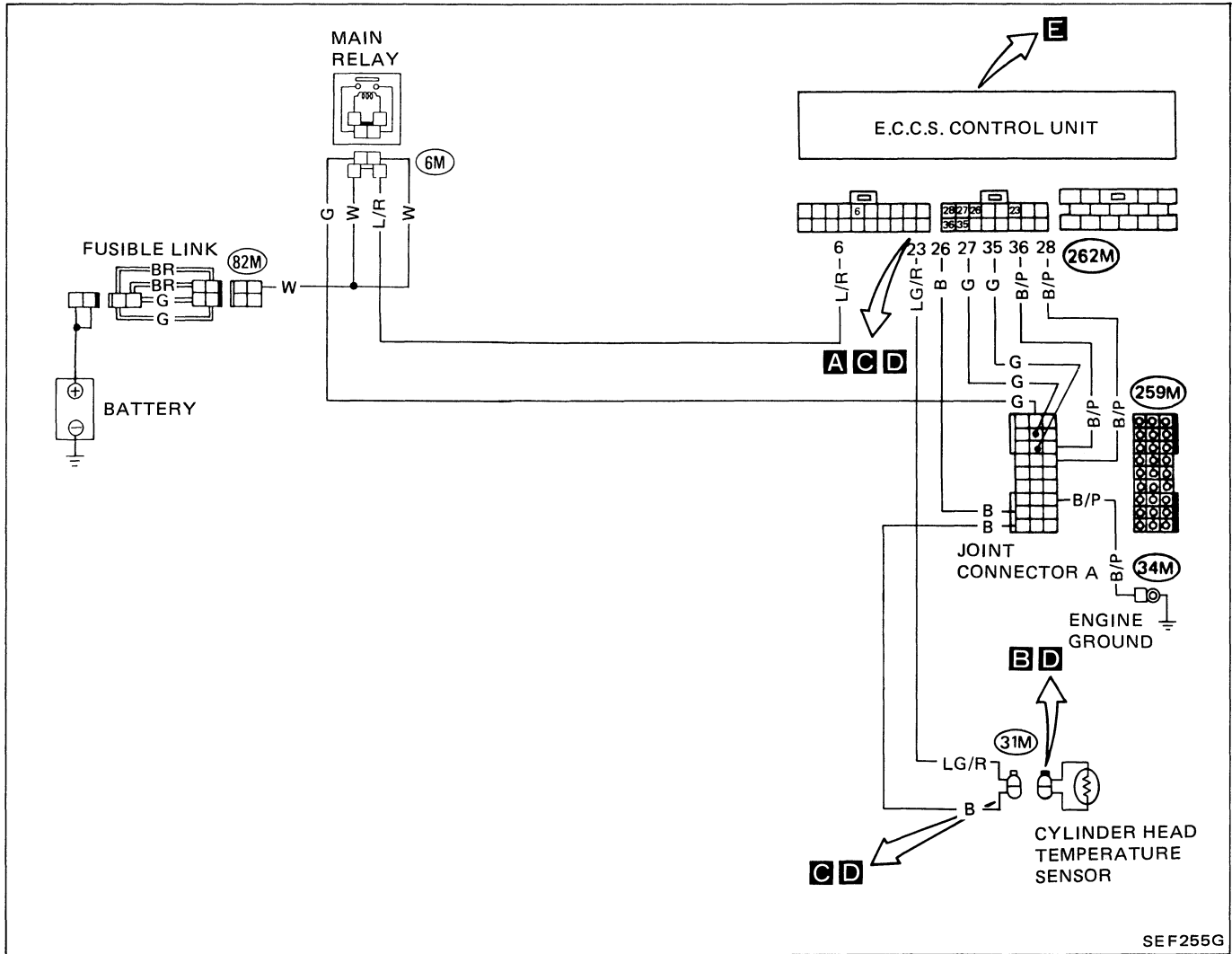

SEF255G

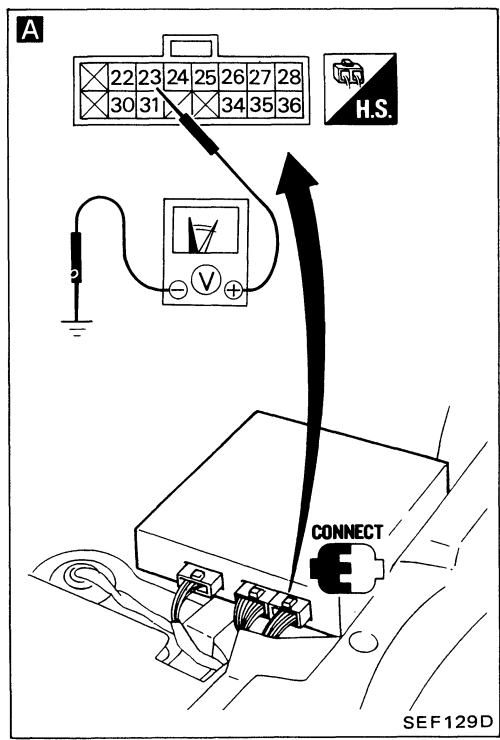

SEF129D

CYLINDER HEAD TEMPERATURE SENSOR (Code No. 13)  (CHECK ENGINE LIGHT ITEM)

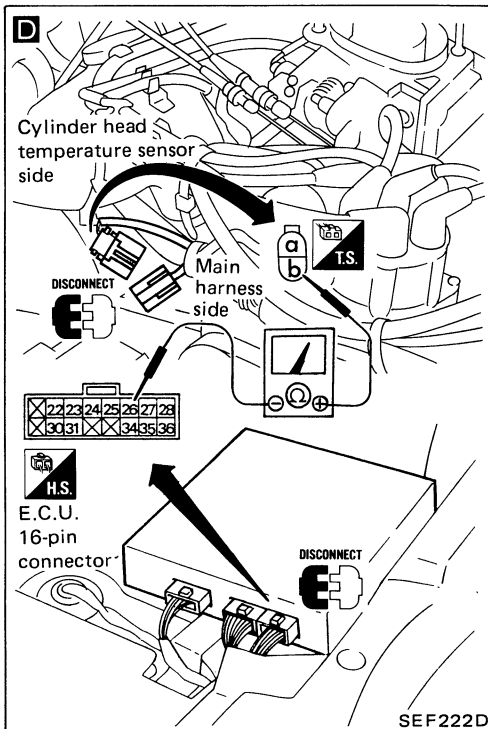
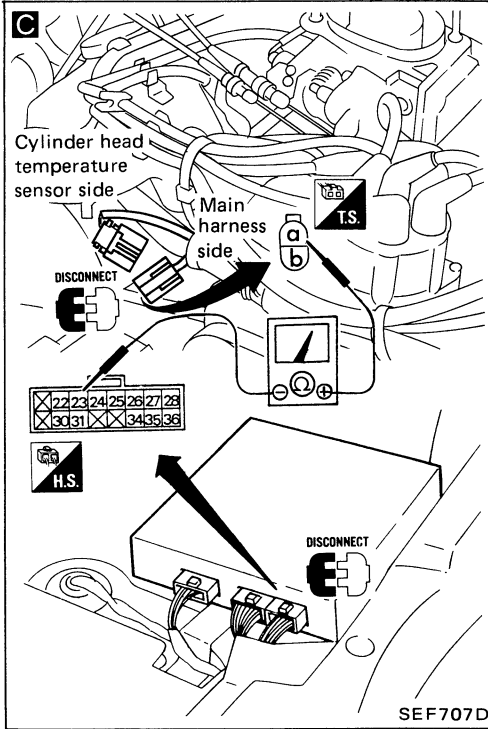
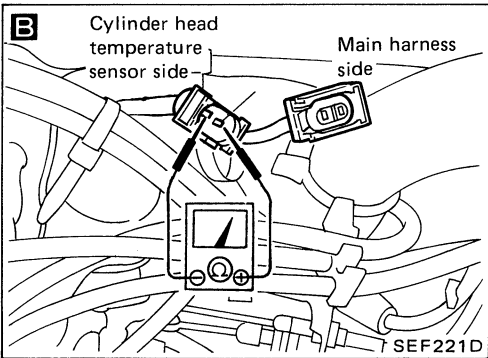

INSPECTION START

A CHECK INPUT SIGNAL.
 1) Remove assist side seat.
 2) Start engine.
 3) Make sure that voltage between E.C.U. terminal ⑳ and ground changes during engine warm up.
Cold → Hot:
Approximately 5 - 0V

N.G.

B 1) Check cylinder head temperature sensor resistance.
 • Stop engine.
 • Disconnect water temperature sensor harness connector.
 • Check resistance between terminals ㉑ and ㉒.

20°C (68°F)	2.3 - 2.7 kΩ
50°C (122°F)	0.77 - 0.87 kΩ
80°C (176°F)	0.30 - 0.33 kΩ

If no continuity, replace water temperature sensor.

2) Check power source for E.C.U. (See page EF & EC-140.)

C 3) Check harness continuity between E.C.U. and cylinder head temperature sensor.
 • Disconnect 16-pin connector from E.C.U.
 • Disconnect cylinder head temperature sensor connector.
 Check resistance between terminal ㉑ and E.C.U. terminal ㉓.
Resistance:
Approximately 0Ω

D CHECK GROUND CIRCUIT.
 1) Stop engine and disconnect 16-pin connector from E.C.U.
 2) Disconnect cylinder head temperature sensor harness connector.
 3) Check resistance between terminal ㉒ and E.C.U. terminal ㉔.
Resistance:
Approximately 0Ω

N.G.

O.K.
 Reinstall any part removed.

1) Check the following items.
 Harness connection between water temperature sensor and ground
 2) Joint connector A

Erase the self-diagnosis memory.

Perform driving test and then perform self-diagnosis (Mode III) again.

N.G.

1) Perform E.C.U. in-output signal inspection test.
 2) If N.G., recheck the E.C.U. pin terminals damage or the connection of E.C.U. harness connector.

O.K.
 INSPECTION END

IGNITION SIGNAL (Code No. 21)

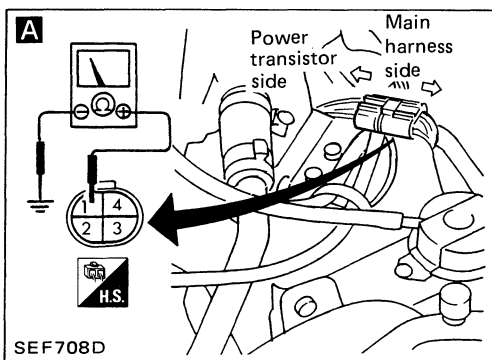
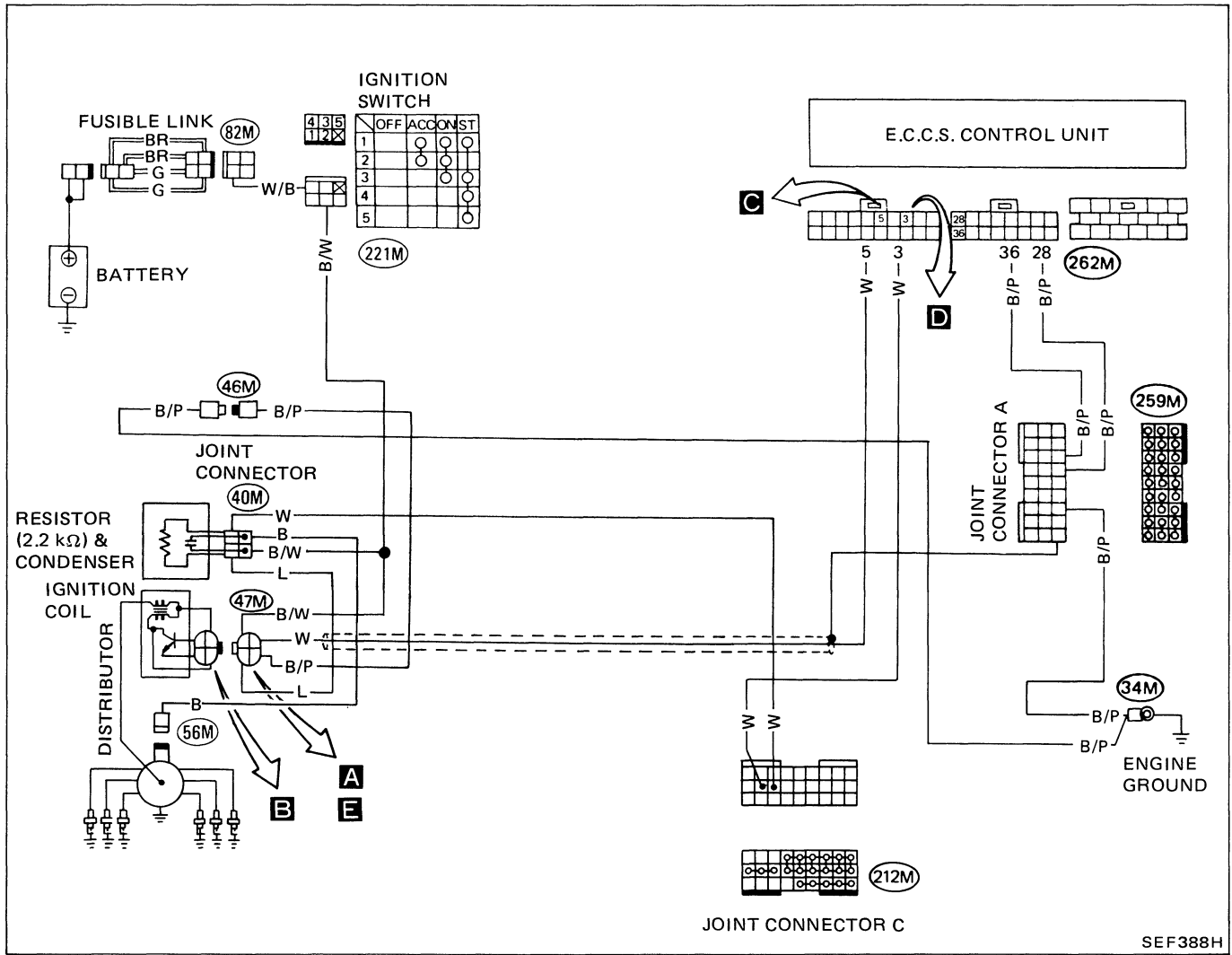

```

    graph TD
      Start([INSPECTION START]) --> Check[CHECK POWER SOURCE.  
1) Turn ignition switch "ON".  
2) Check voltage between terminal ① and ground.  
Battery voltage should exist.]
      Check -- O.K. --> End(( ))
      Check -- N.G. --> Items[Check the following items.  
1) Harness connection between battery and power transistor  
2) "G" fusible link  
3) Ignition switch]
  
```

SEF708D

SEF388H

IGNITION SIGNAL (Code No. 21)

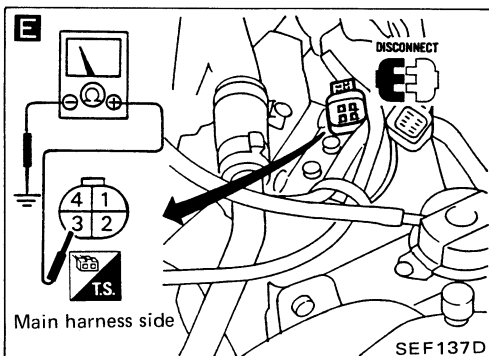
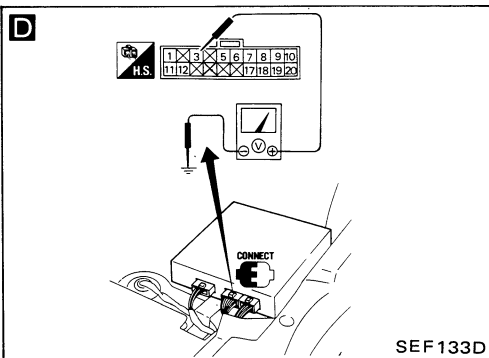
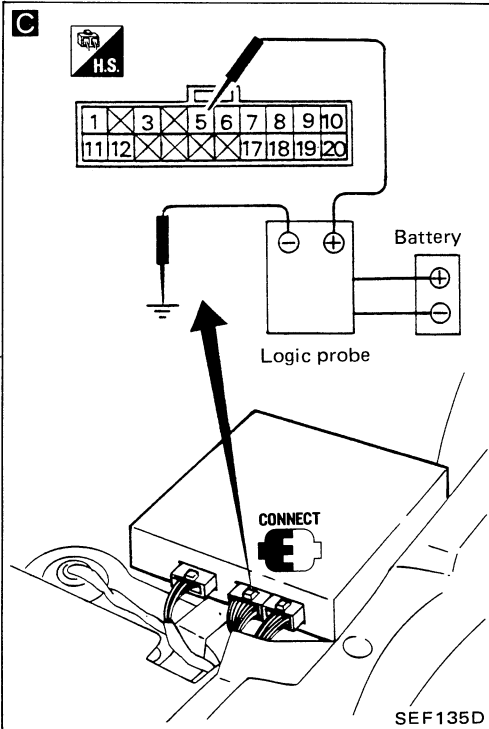
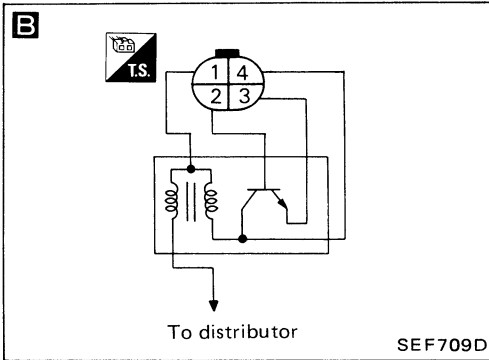

C

CHECK INPUT SIGNAL.

- 1) Remove assist side seat.
- 2) Start engine.
- 3) Make sure that pulse signals exist between ⑤ and ground with logic probe.

Pulse signal should exist.

N.G.

- 1) Stop engine and check harness continuity between power transistor and E.C.U.
- B** 2) Check power transistor with circuit tester.
 - Disconnect harness connector for ignition coil and power transistor.
 - Do not disconnect T-type harness connector for ignition coil.**

- ①: To ignition coil (+) side
- ②: To E.C.U.
- ③: To engine ground
- ④: To ignition coil (-) side

Terminal No.	Tester polarity	Continuity
① or ④	+	No continuity
③	-	
① or ④	-	Continuity should exist.
③	+	
① or ④	+	No continuity
②	-	
① or ④	-	Continuity should exist.
②	+	

D

CHECK INPUT SIGNAL.

- 1) Stop engine.
- 2) Turn ignition switch "ON".
- 3) Check voltage between terminal ③ and ground.

Battery voltage should exist.

N.G.

If N.G., replace power transistor.

- 3) Check "G" fusible link.
- 4) Check ignition switch.
- 5) Check continuity of ignition coil.
- 6) Joint connector

E

CHECK GROUND CIRCUIT.

- 1) Turn ignition switch "OFF".
- 2) Disconnect power transistor harness connector.
- 3) Check resistance between terminal ③ and ground.

Resistance:
Approximately 0Ω

N.G.

Check harness continuity between E.C.U. and battery.

O.K.

Reinstall any part removed.

N.G.

Check the following items.

- 1) Harness connection between power transistor and ground
- 2) Joint connector
- 3) Engine ground
- 4) Power transistor earth

Erase the self-diagnosis memory.

Perform driving test and then perform self-diagnosis (Mode III) again.

N.G.

- 1) Perform E.C.U. input/output signal inspection test.
- 2) If N.G., recheck the E.C.U. pin terminals damage or the connection of E.C.U. harness connector.

O.K.

INSPECTION END

ENGINE CONTROL UNIT (Code No. 31) (CHECK ENGINE LIGHT ITEM)

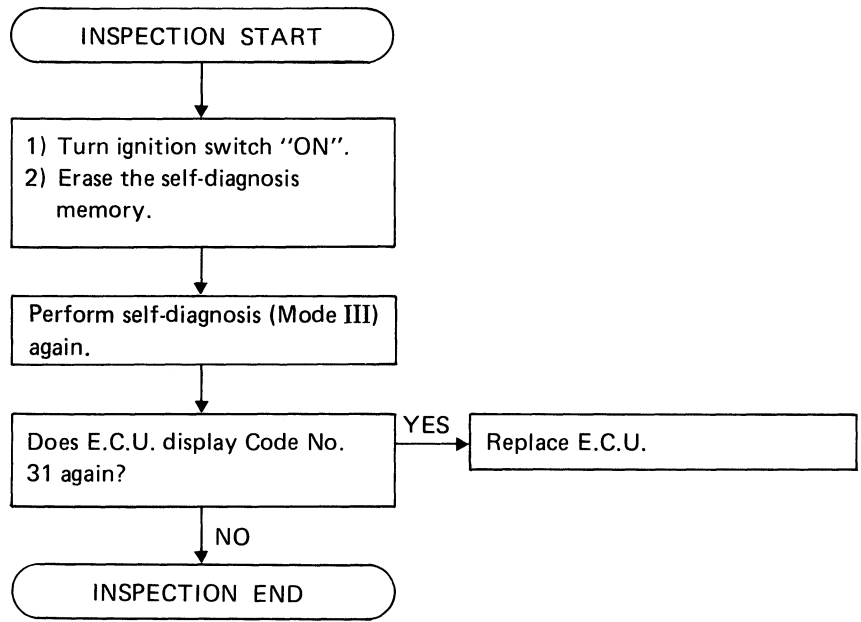

NOTE

ELECTRONIC CONTROL SYSTEM INSPECTION

VG30i

E.G.R. FUNCTION (Code No. 32)  (CHECK ENGINE LIGHT ITEM): For California model
(Not self-diagnostic item): For Non-California model

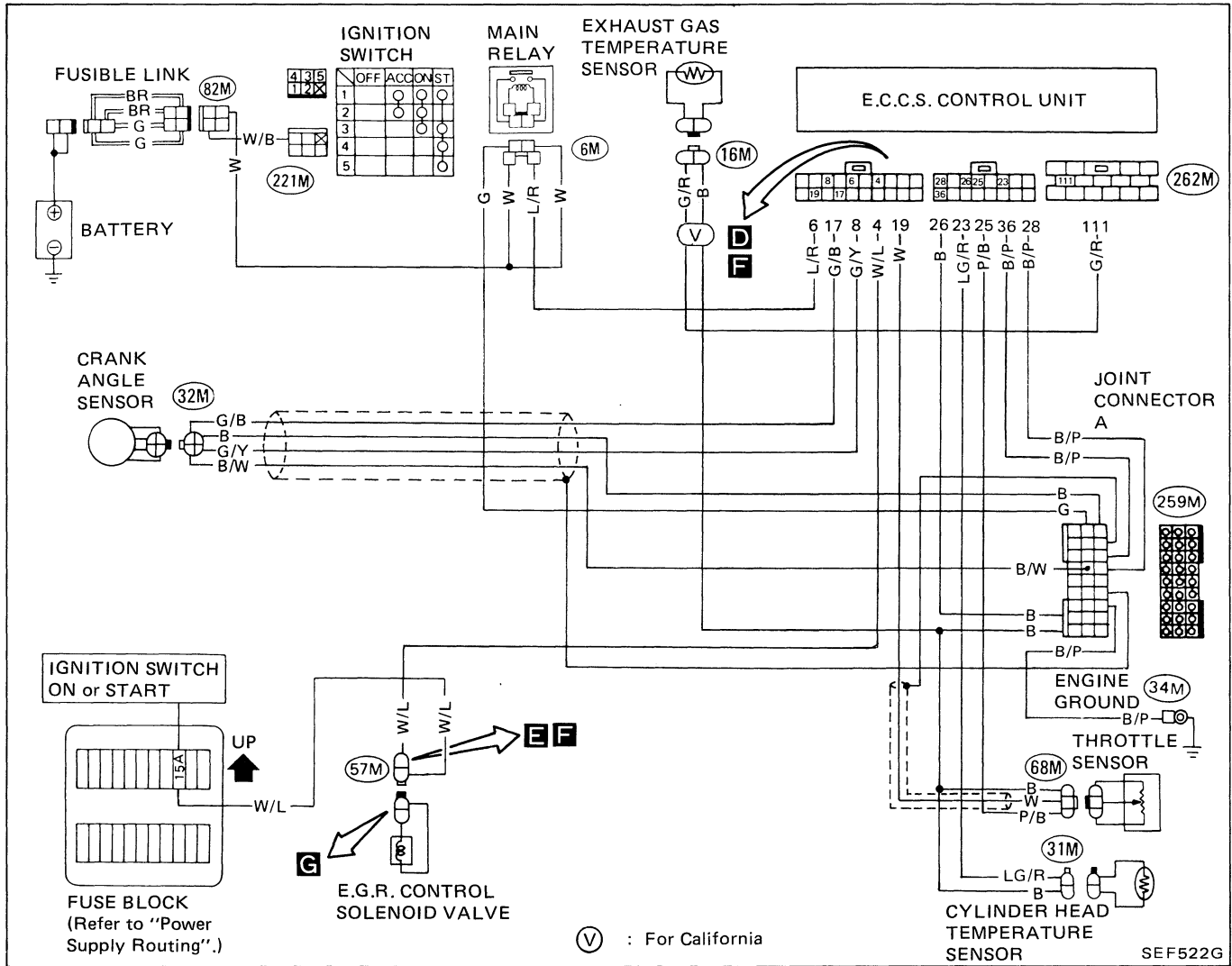

The following is necessary to perform this inspection.

1. Pull out E.C.U. installed under the assist seat.
2. Warm up engine sufficiently.

E.G.R. FUNCTION (Code No. 32) (CHECK ENGINE LIGHT ITEM): For California model
(Not self-diagnostic item): For Non-California model

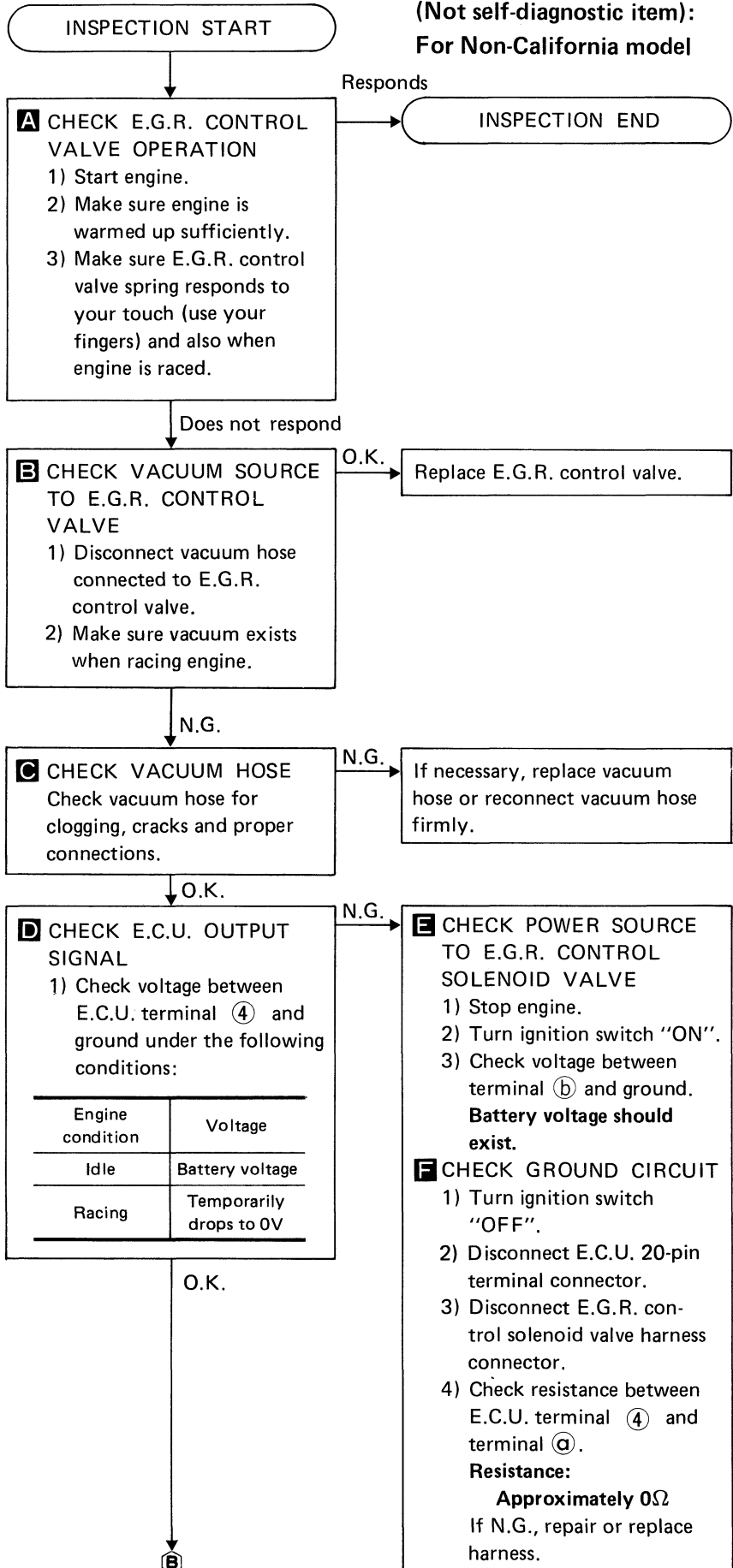
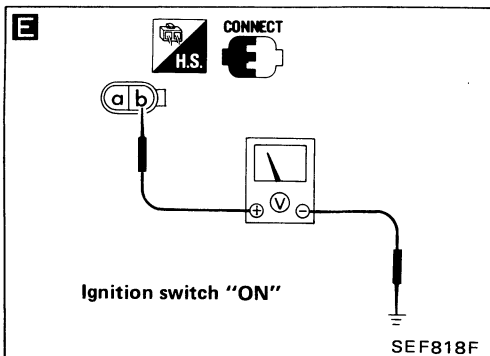
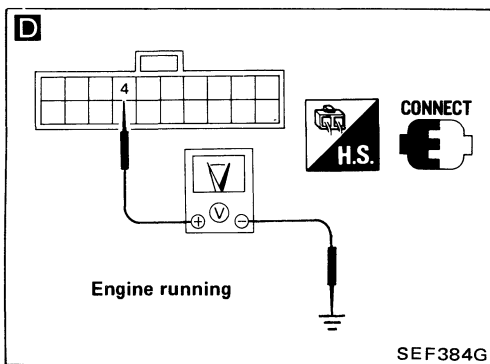
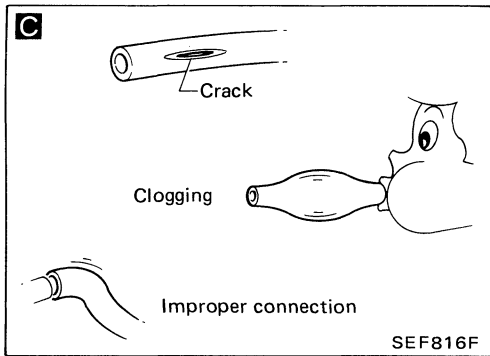
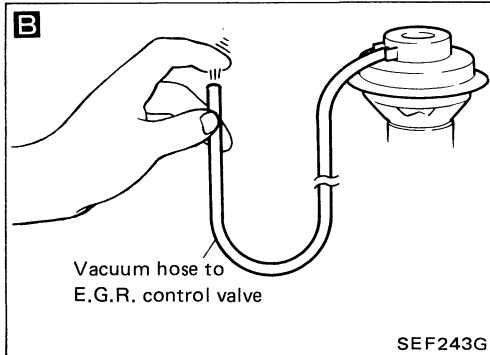
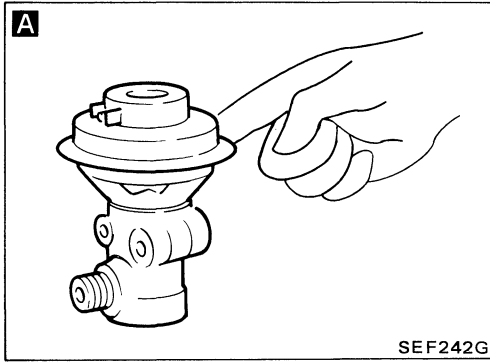

E.G.R. FUNCTION (Code No. 32) (CHECK ENGINE LIGHT ITEM): For California model
 (Not self-diagnostic item):
 For Non-California model

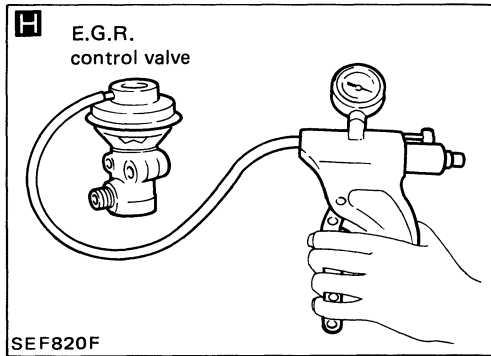
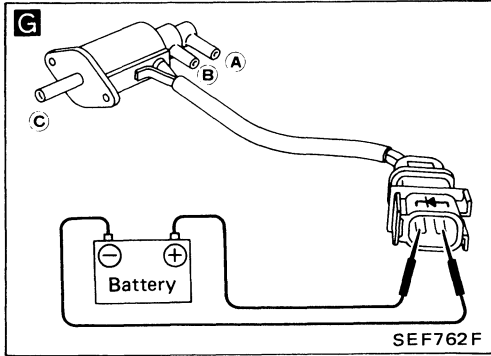
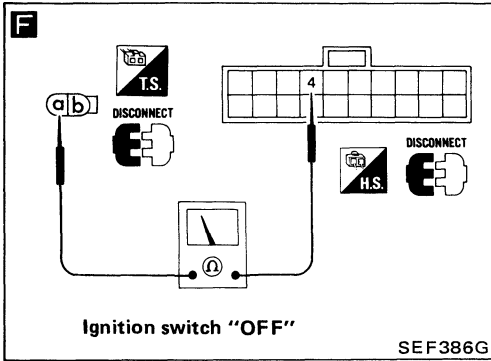

G CHECK E.G.R. CONTROL SOLENOID VALVE

- 1) Stop engine.
- 2) Remove E.G.R. control solenoid valve from vehicle.
- 3) Check the port continuity.

Solenoid valve	Continuity
When current flows	A - B
When current does not flow	B - C

N.G. → Replace E.G.R. control solenoid valve.

O.K.

H CHECK E.G.R. CONTROL VALVE

- 1) Remove E.G.R. control valve from vehicle.
- 2) Apply vacuum to E.G.R. vacuum port with a hand vacuum pump.

E.G.R. control valve spring should lift.

N.G. → Valve spring may be stuck. Clean if necessary. If this does not correct trouble, replace E.G.R. control valve.

O.K. → For Non-California model
 INSPECTION END

O.K. For California model

Check resistance of exhaust gas temperature sensor.
 (See page EF & EC-110.)

Reinstall any part removed.

Erase the self-diagnosis memory. Make sure Code No. 55 is displayed in Mode III.

I Perform driving test.

- 1) Warm up engine sufficiently.
- 2) Use test driving modes indicated in figure **I**.

J Make sure check engine light does not come "ON" during driving test.

Comes "ON" → Perform self-diagnosis and find malfunction code. According to displayed code No., perform electronic control system inspection.

Does not come "ON" → INSPECTION END

E.G.R. FUNCTION (Code No. 32)  **(CHECK ENGINE LIGHT ITEM): For California model**
(Not self-diagnostic item): For Non-California model

I

Test condition

Drive vehicle under the following conditions using a suitable shift position.

- Engine speed:
 M/T: 2,200±400 rpm
 A/T: 2,100±300 rpm
- Intake manifold vacuum:
 M/T: -40.0±5.3 kPa
 (-300±40 mmHg, -11.81±1.57 inHg)
 A/T: -38.7±6.7 kPa
 (-290±50 mmHg, -11.42±1.97 inHg)

Driving mode

- Ⓐ : Test condition
- Ⓑ : 16 seconds or more

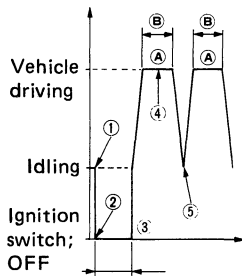

Until green and red LEDs go off.

- ① Start engine and warm it up sufficiently.
- ② Turn off ignition switch and keep it off until green and red LEDs go off.
- ③ Start engine and make sure that air conditioner switch and rear defogger are turned "OFF" during driving test.
- ④ Shift to suitable gear position and drive in "Test condition" for at least 16 seconds.
- ⑤ Decrease engine revolutions to less than 1,500 rpm.
- ⑥ Repeat steps ④ through ⑤ at least 1 time.

SEF037H

J

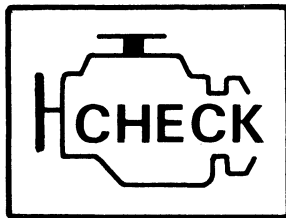

CHECK ENGINE LIGHT

SEF924F

EXHAUST GAS SENSOR (Code No. 33) (CHECK ENGINE LIGHT ITEM)

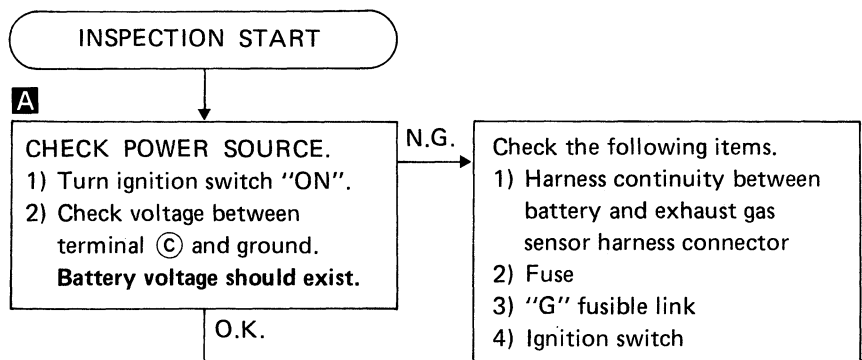
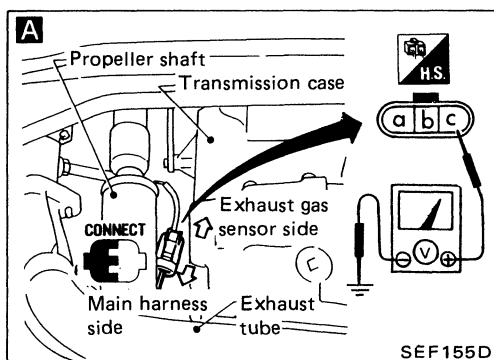
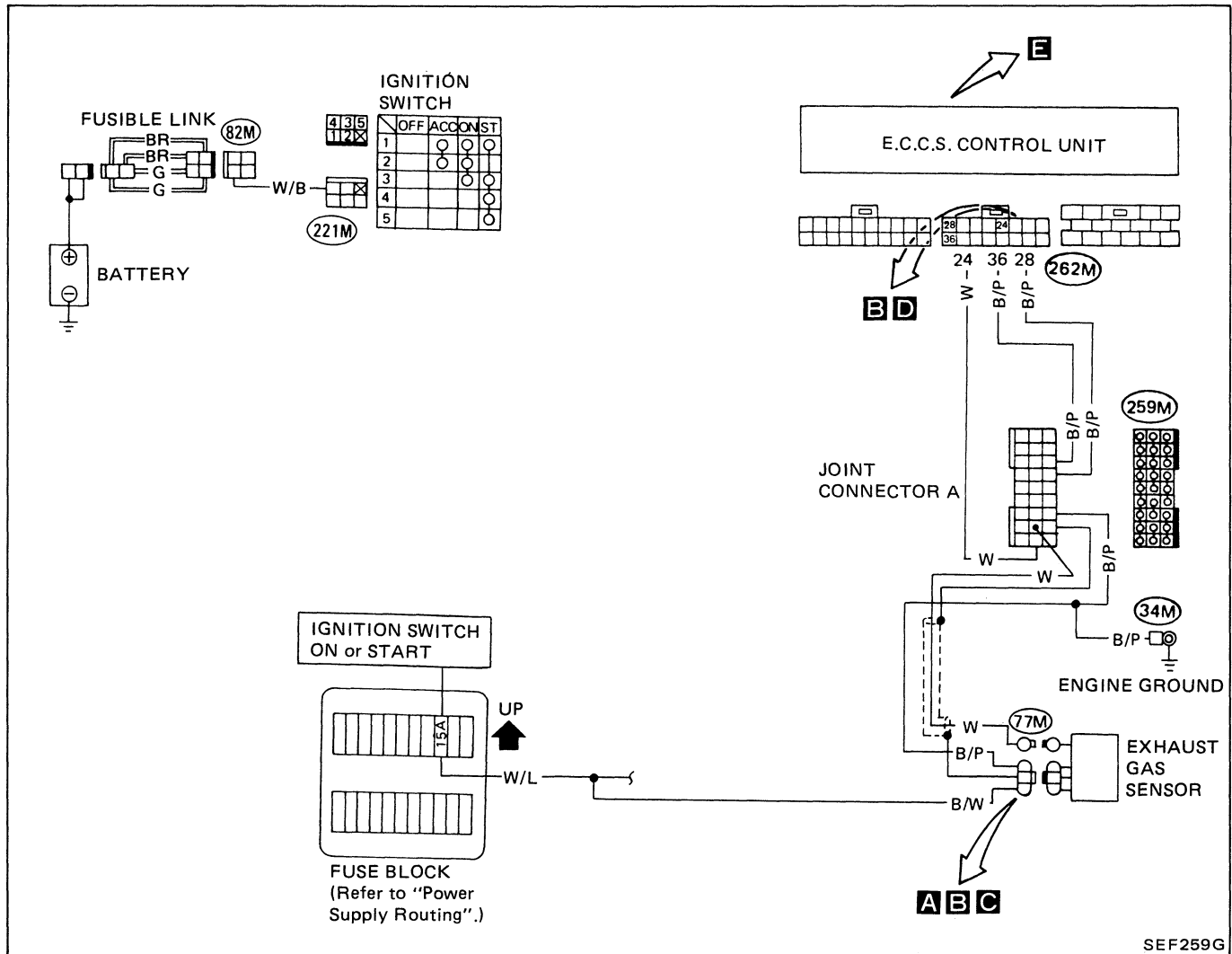

EXHAUST GAS SENSOR (Code No. 33)  (CHECK ENGINE LIGHT ITEM)

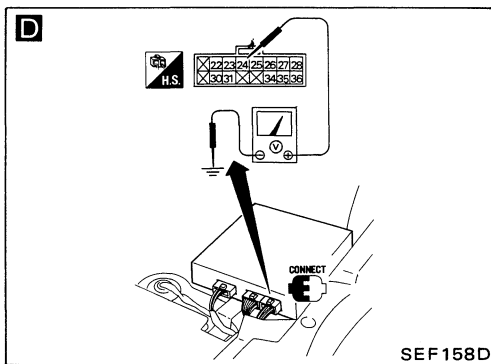
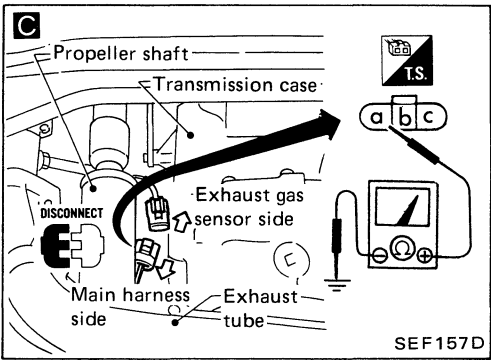
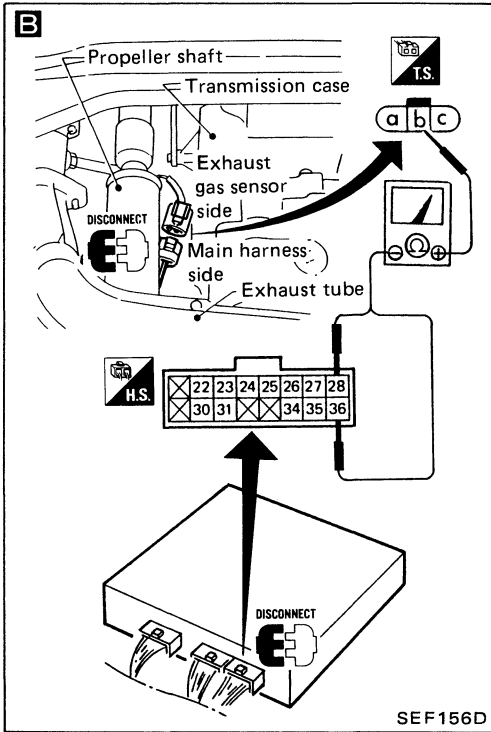

CHECK GROUND CIRCUIT.

- 1) Turn ignition switch "OFF".
- 2) Disconnect exhaust gas sensor harness connector.
- B** 3) Check resistance between terminal **b** and E.C.U. terminals **28**, **36** (Shield wire ground).
Resistance:
Approximately 0Ω
- C** 4) Check resistance between terminal **a** and ground.
Resistance:
Approximately 0Ω

N.G. → Check the following items.

- 1) Harness continuity between exhaust gas sensor harness connector and ground
- 2) E.C.U. ground circuit (See page EF & EC-140.)
- 3) Joint connector A
- 4) Engine ground

CHECK INPUT SIGNAL.

- 1) Remove assist side seat.
- 2) Reconnect exhaust gas sensor harness connector.
- 3) Warm up engine sufficiently.
- 4) Depress accelerator pedal fully.
- 5) Check voltage between terminal **24** and ground.
Voltage:
Approximately 1.0V
- 6) Check voltage when A.I.V. system operates. (See page EF & EC-144.)
Voltage:
Approximately 0V

N.G. → Check harness continuity between exhaust gas sensor and E.C.U.
If O.K., replace exhaust gas sensor.

Reinstall any part removed.

Erase the self-diagnosis memory. Make sure Code No. 55 is displayed in Mode III.

- 1) Warm up engine sufficiently.
- 2) Set diagnosis mode to Mode I.
- 3) Make sure that inspection lamp (Green) on E.C.U. goes on and off periodically more than 5 times during 10 seconds at 2,000 rpm.

N.G. → Perform MIXTURE RATIO FEEDBACK SYSTEM INSPECTION. (See page EF & EC-205.)

O.K. → INSPECTION END

EXHAUST GAS TEMPERATURE SENSOR (Code No. 35) (CHECK ENGINE LIGHT ITEM); CALIFORNIA MODEL ONLY

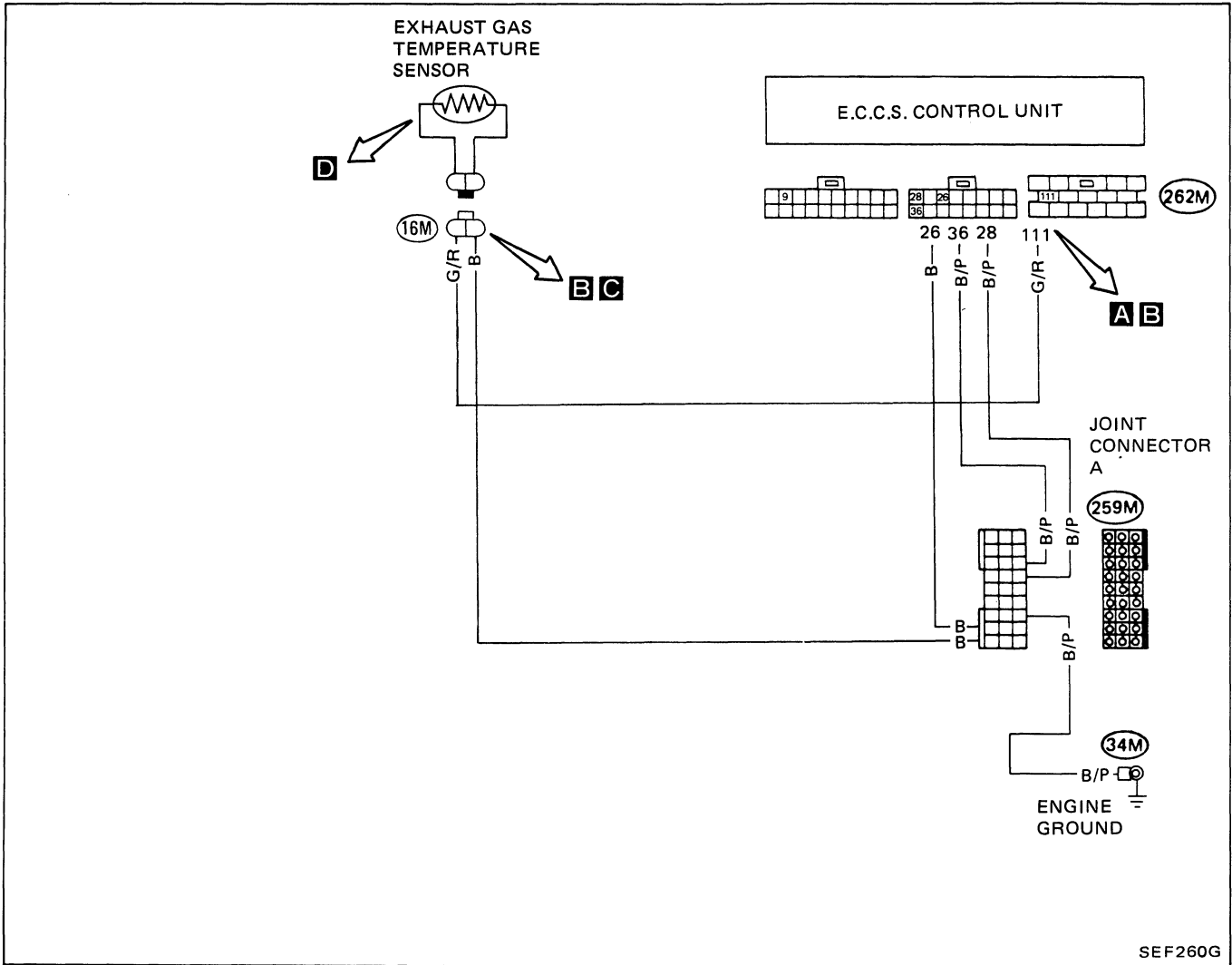

The following is necessary to perform this inspection.

1. Pull out E.C.U. installed under the assist seat.
2.
 - Disconnect vacuum hose connected to E.G.R. control valve.
 - Connect a hand vacuum pump to E.G.R. control valve.
3. Warm up engine sufficiently.

EXHAUST GAS TEMPERATURE SENSOR (Code No. 35)  (CHECK ENGINE LIGHT ITEM); CALIFORNIA MODEL ONLY

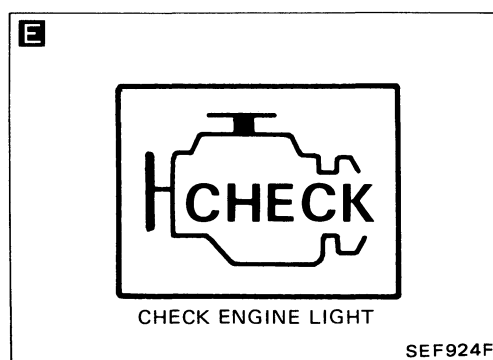
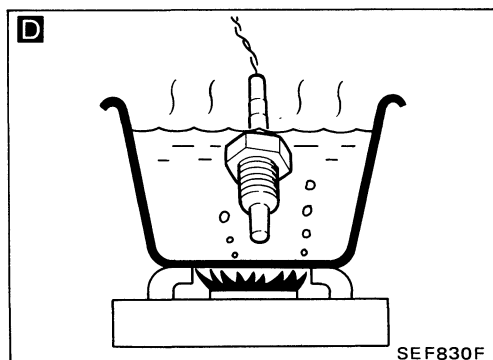
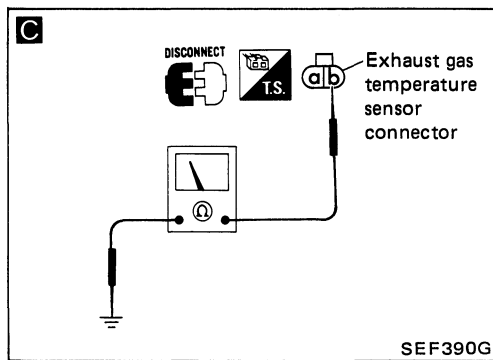
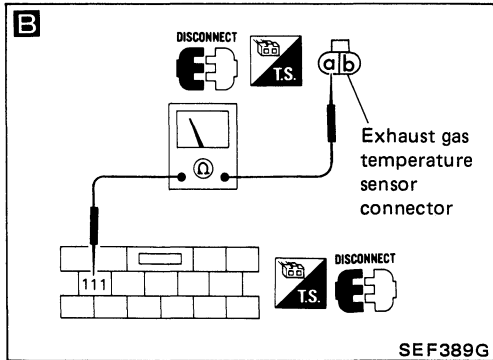
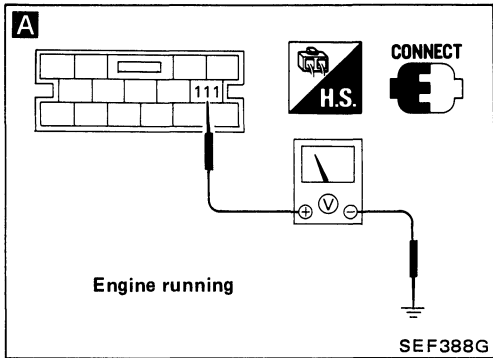

INSPECTION START

A CHECK INPUT SIGNAL O.K. → INSPECTION END

- 1) Start engine and keep engine speed at approximately 2,000 rpm.
- 2) Check voltage between E.C.U. terminal (111) and ground under the following conditions:

Condition	Voltage
When vacuum is not applied to E.G.R. control valve	1.0V or more
When vacuum is applied to E.G.R. control valve	0 - 1.0V

A sufficient vacuum applied with a hand vacuum pump may cause the engine to stall.

N.G. →

B CHECK HARNESS CONTINUITY BETWEEN E.C.U. AND EXHAUST GAS TEMPERATURE SENSOR N.G. →

- 1) Check middle harness connector connection.
- 2) If necessary, repair or replace harness.

O.K. →

C CHECK GROUND CIRCUIT N.G. →

Check continuity between ground and (b).

- 1) Check middle harness connector connection.
- 2) If necessary, repair or replace harness.

O.K. →

A

EXHAUST GAS TEMPERATURE SENSOR (Code No. 35)  (CHECK ENGINE LIGHT ITEM); CALIFORNIA MODEL ONLY

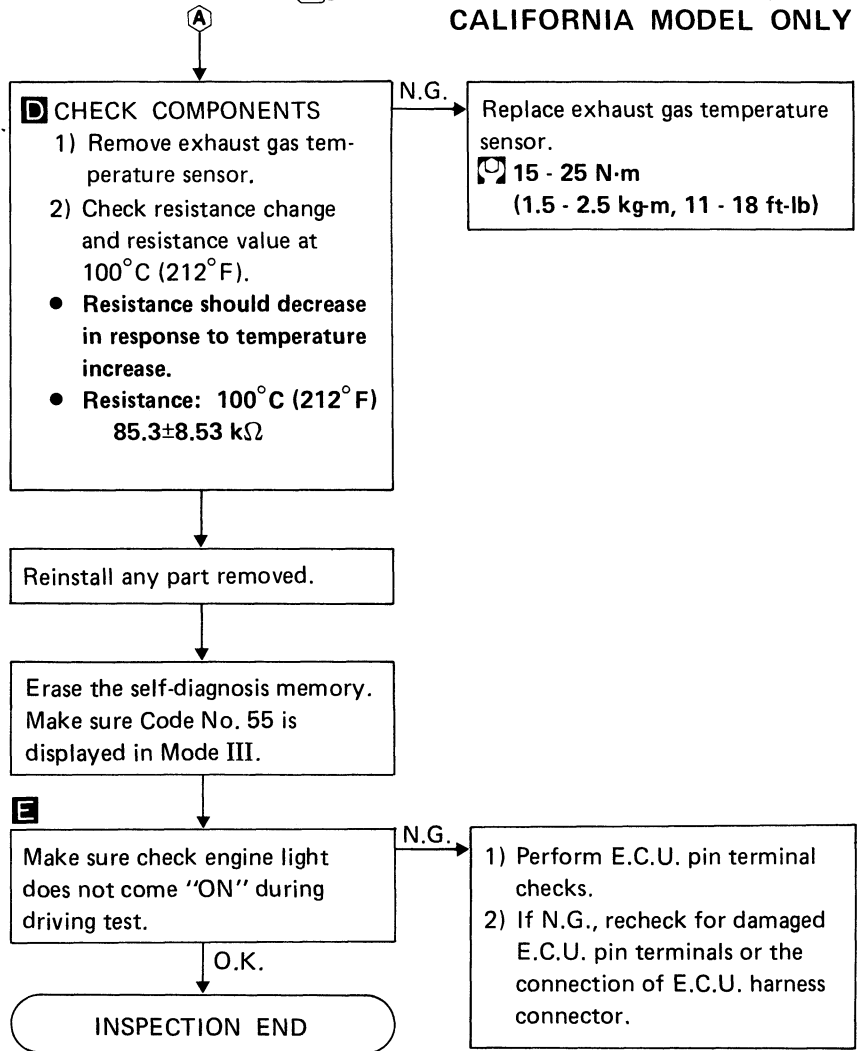

NOTE

THROTTLE SENSOR (Code No. 43)  (CHECK ENGINE LIGHT ITEM)

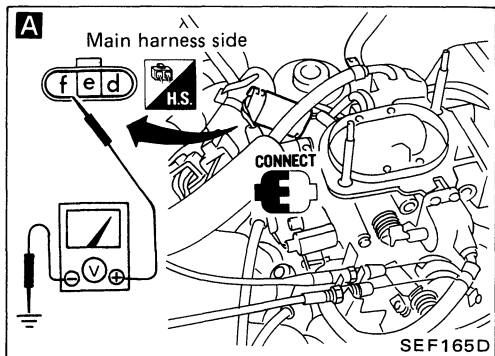
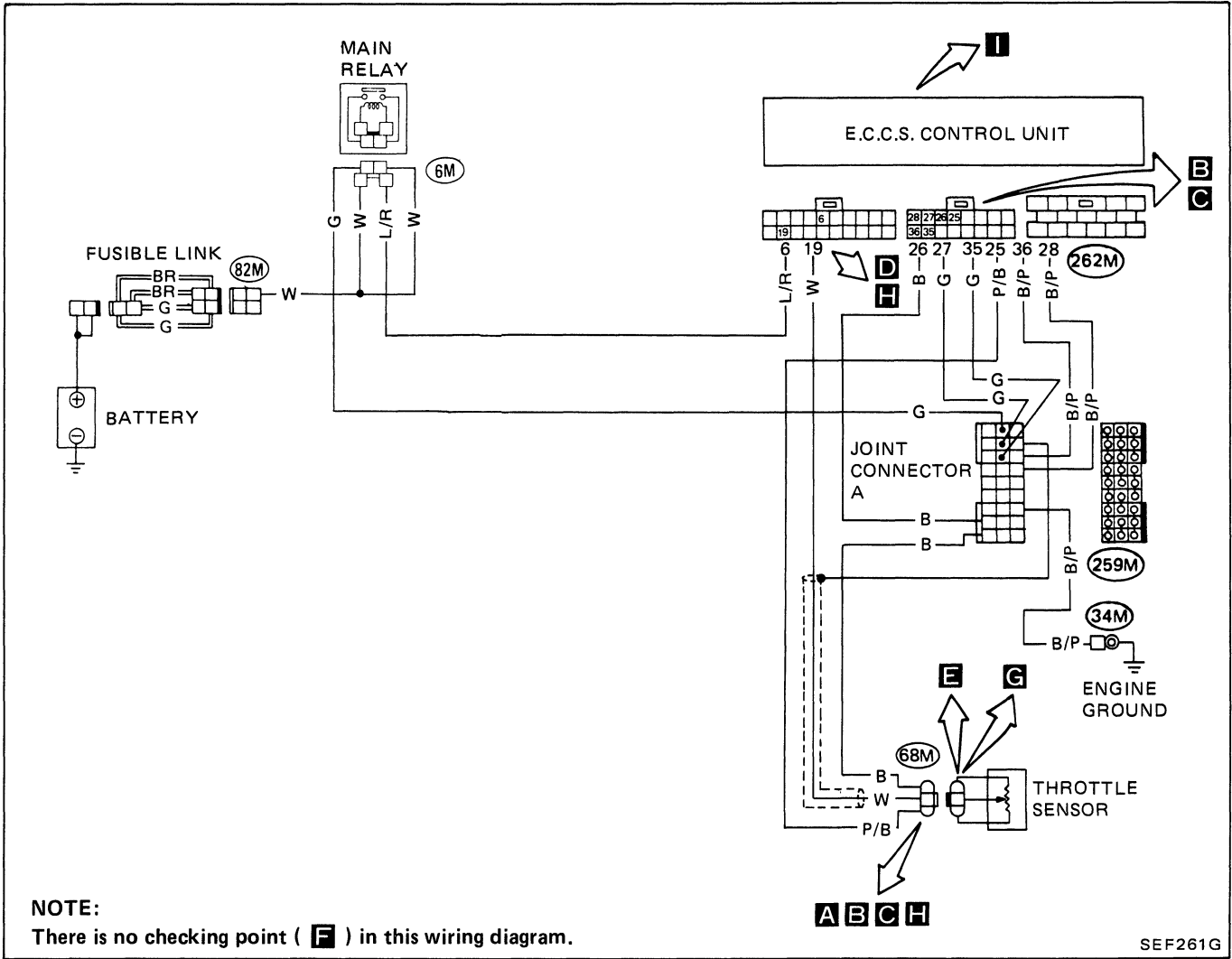

THROTTLE SENSOR (Code No. 43) CHECK (CHECK ENGINE LIGHT ITEM)

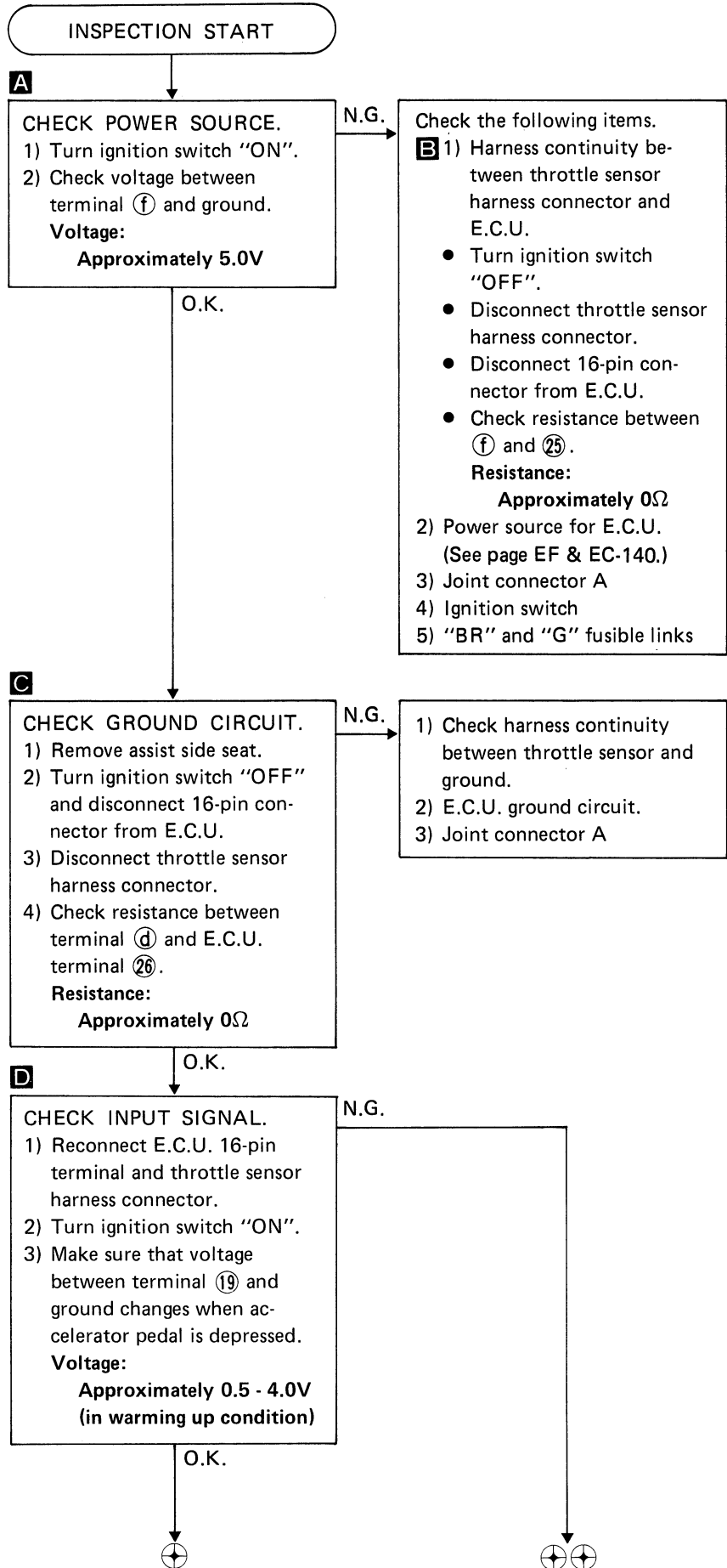
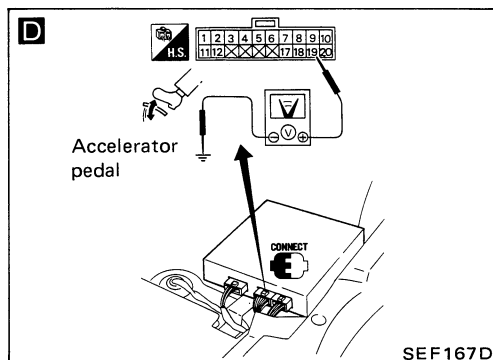
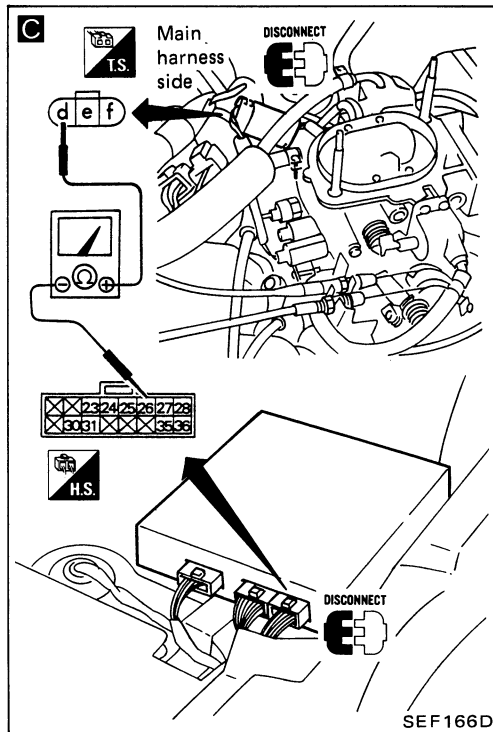
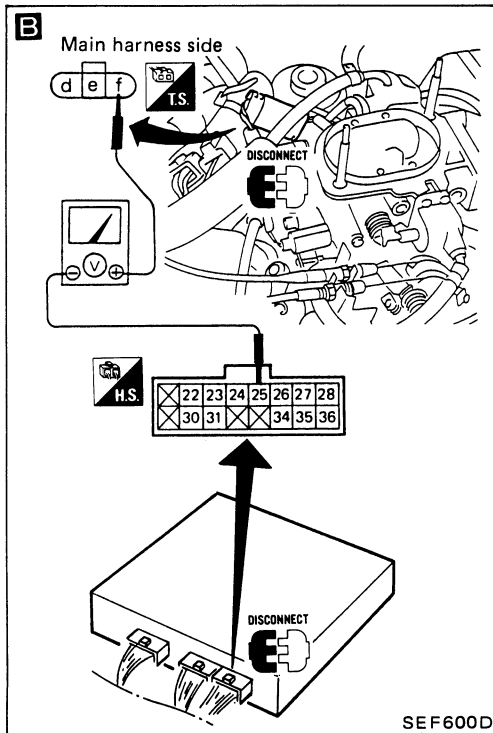

THROTTLE SENSOR (Code No. 43) CHECK (CHECK ENGINE LIGHT ITEM)

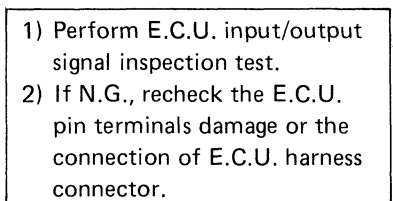
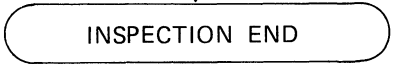
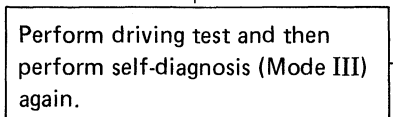
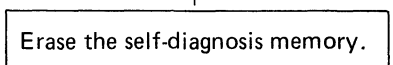
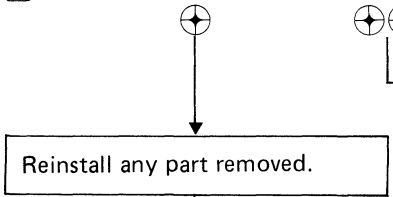
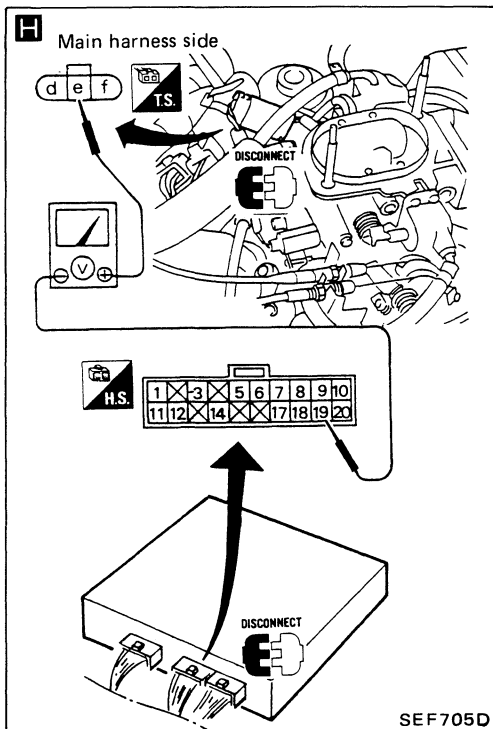
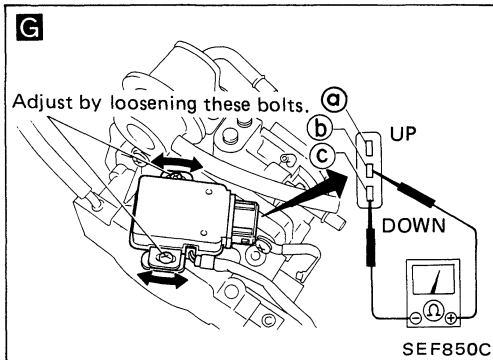
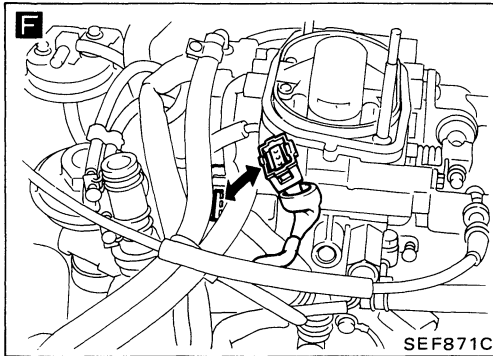
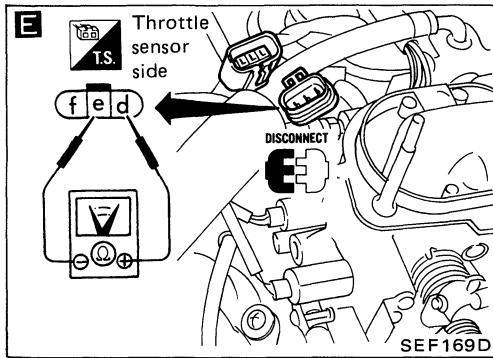

- 1) Disconnect throttle sensor harness connector.
- E** 2) Make sure that resistance between **d** and **e** changes when opening throttle valve manually. **Resistance should change.** If not, replace throttle sensor.
- 3) Check idle switch OFF → ON speed.
 - Reconnect throttle sensor harness connector.
 - Remove air cleaner.
 - Put a suitable plug into disconnected vacuum hose.
- F** • Disconnect idle switch harness connector.
- Start and warm up engine sufficiently.
- Check idle switch OFF → ON speed with circuit tester, closing throttle valve manually.
- Idle switch OFF → ON speed:**
M/T: Idle speed + 250±150 rpm
A/T: Engine speed (Idle speed in "N" position) + 250±150 rpm
- G** • If N.G., loosen throttle sensor installing screws, then set idle switch OFF → ON speed to the specified value by turning throttle sensor body. (Connect circuit tester with terminals **b** and **c** on idle switch side and find out OFF → ON point.)
 - Tighten throttle sensor installing screws after setting.
- H** 4) Check harness continuity between throttle sensor and E.C.U.
 - Disconnect harness connector for throttle sensor.
 - Disconnect 16-pin connector from E.C.U.
 - Check resistance between terminal **e** and E.C.U. terminal **19**. **Resistance: Approximately 0Ω**

ELECTRONIC CONTROL SYSTEM INSPECTION

NOTE

INJECTOR LEAK (Code No. 45) (CHECK ENGINE LIGHT ITEM); CALIFORNIA MODEL ONLY

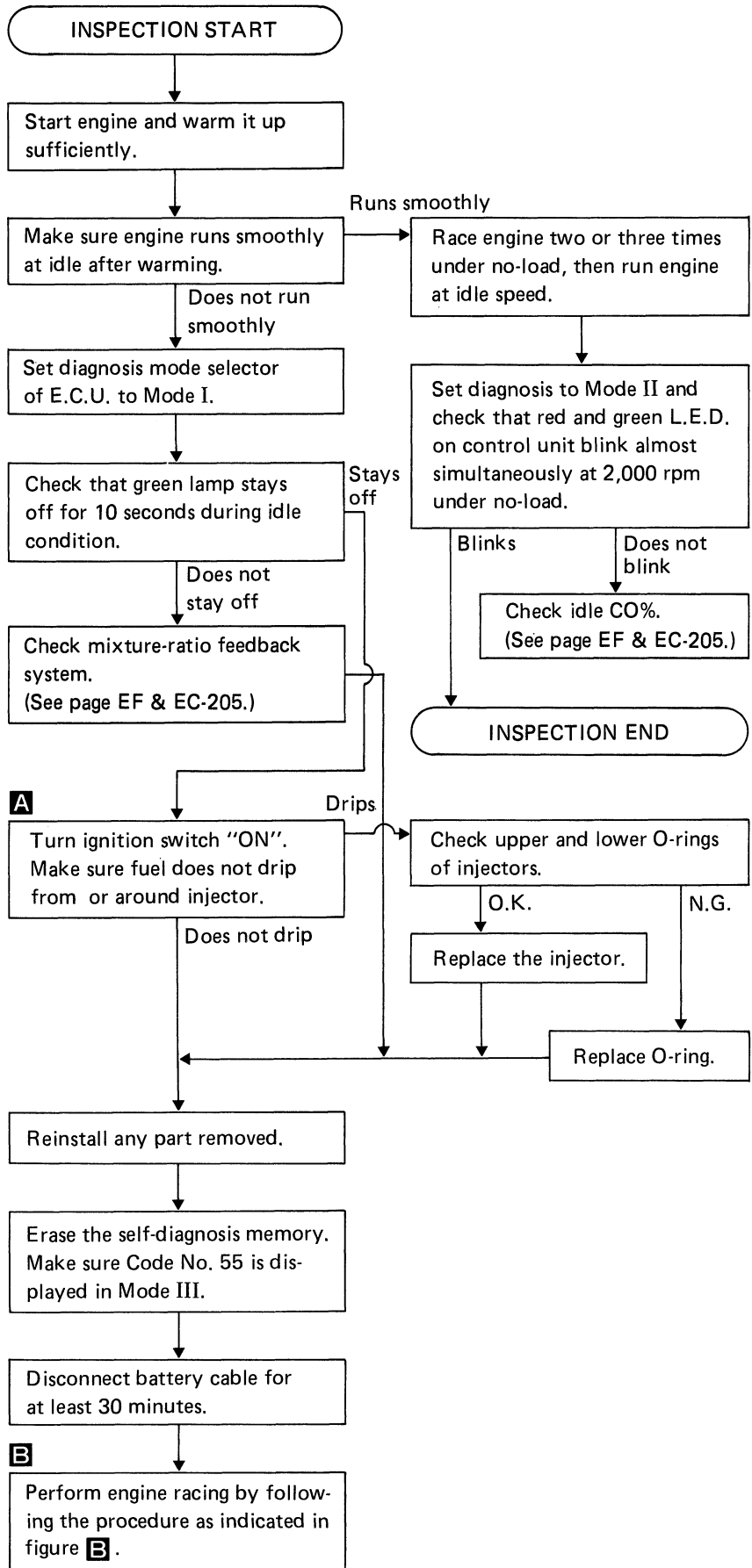
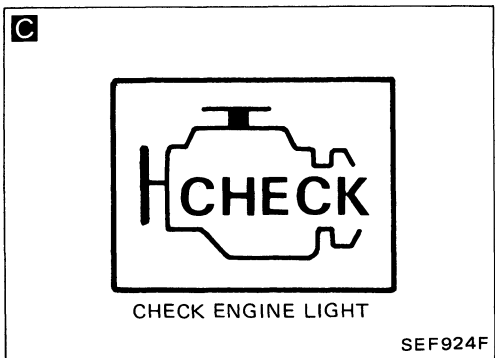
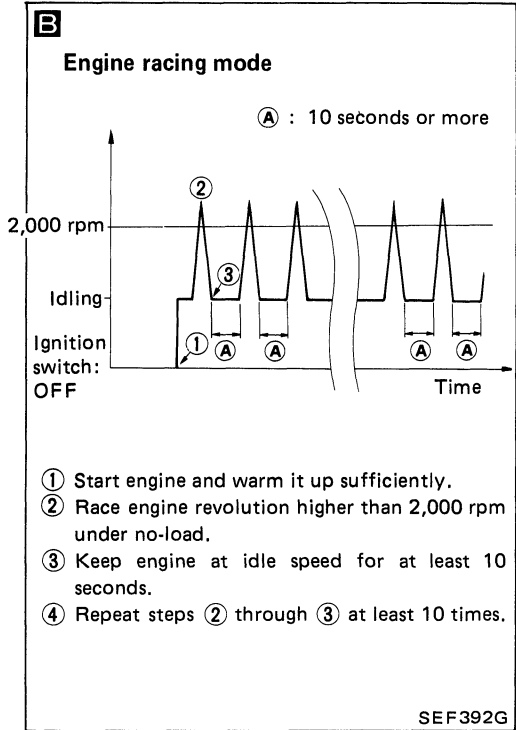
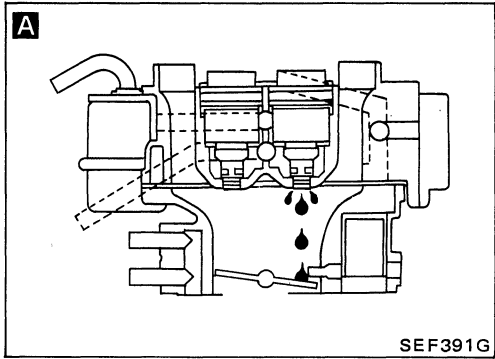

INJECTOR LEAK (Code No. 45)  (CHECK ENGINE LIGHT ITEM); CALIFORNIA MODEL ONLY

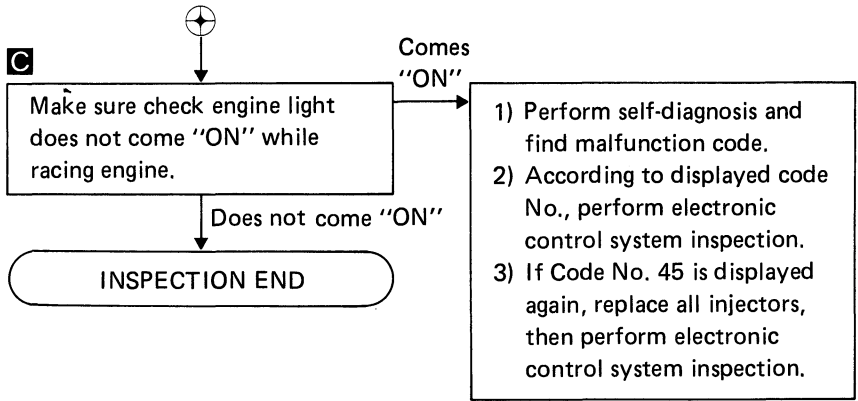

INJECTOR (Code No. 51)

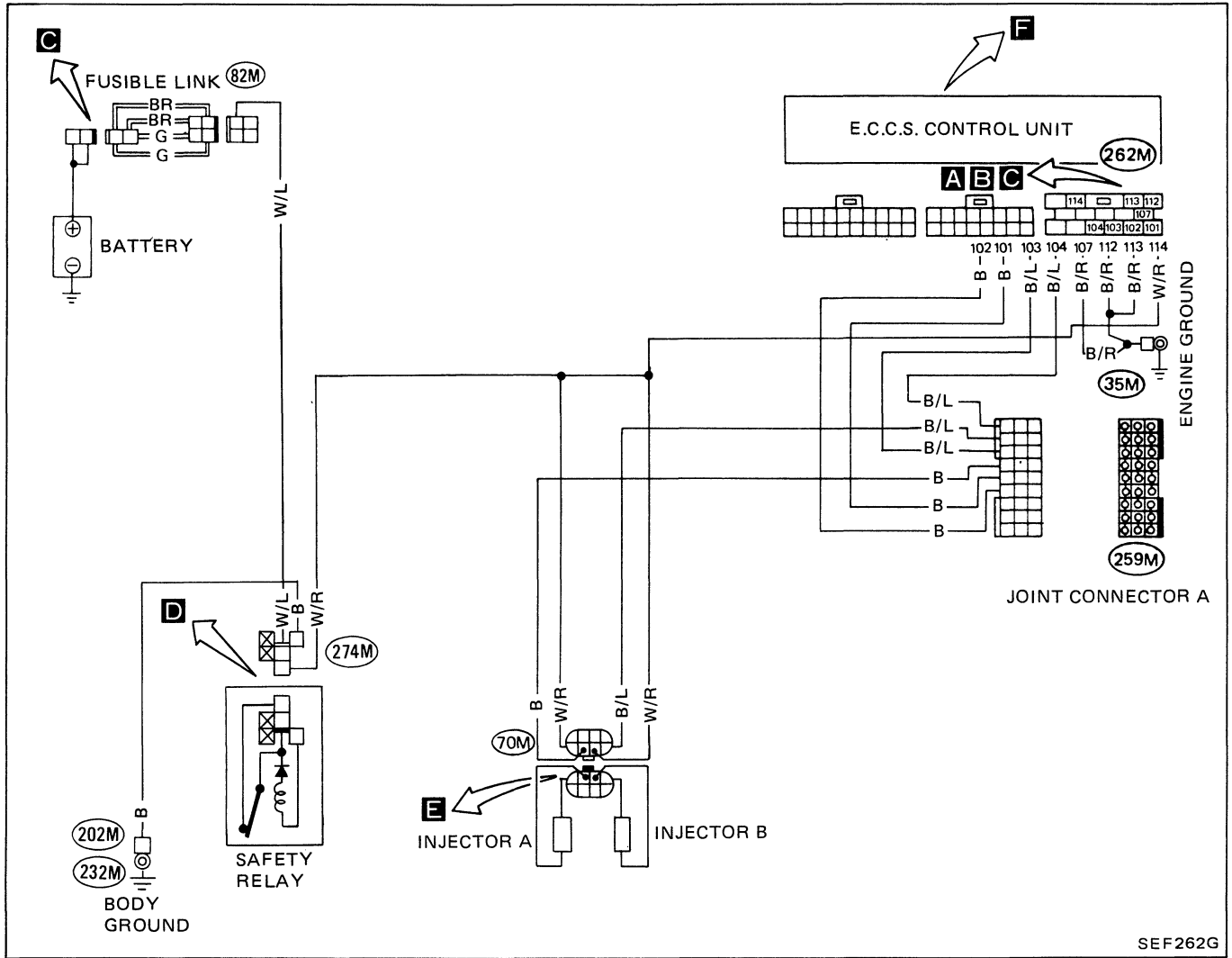

SEF262G

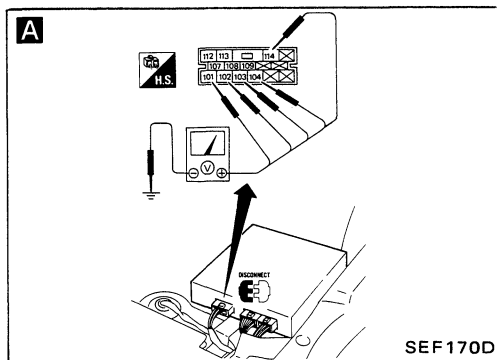

SEF170D

INJECTOR (Code No. 51)

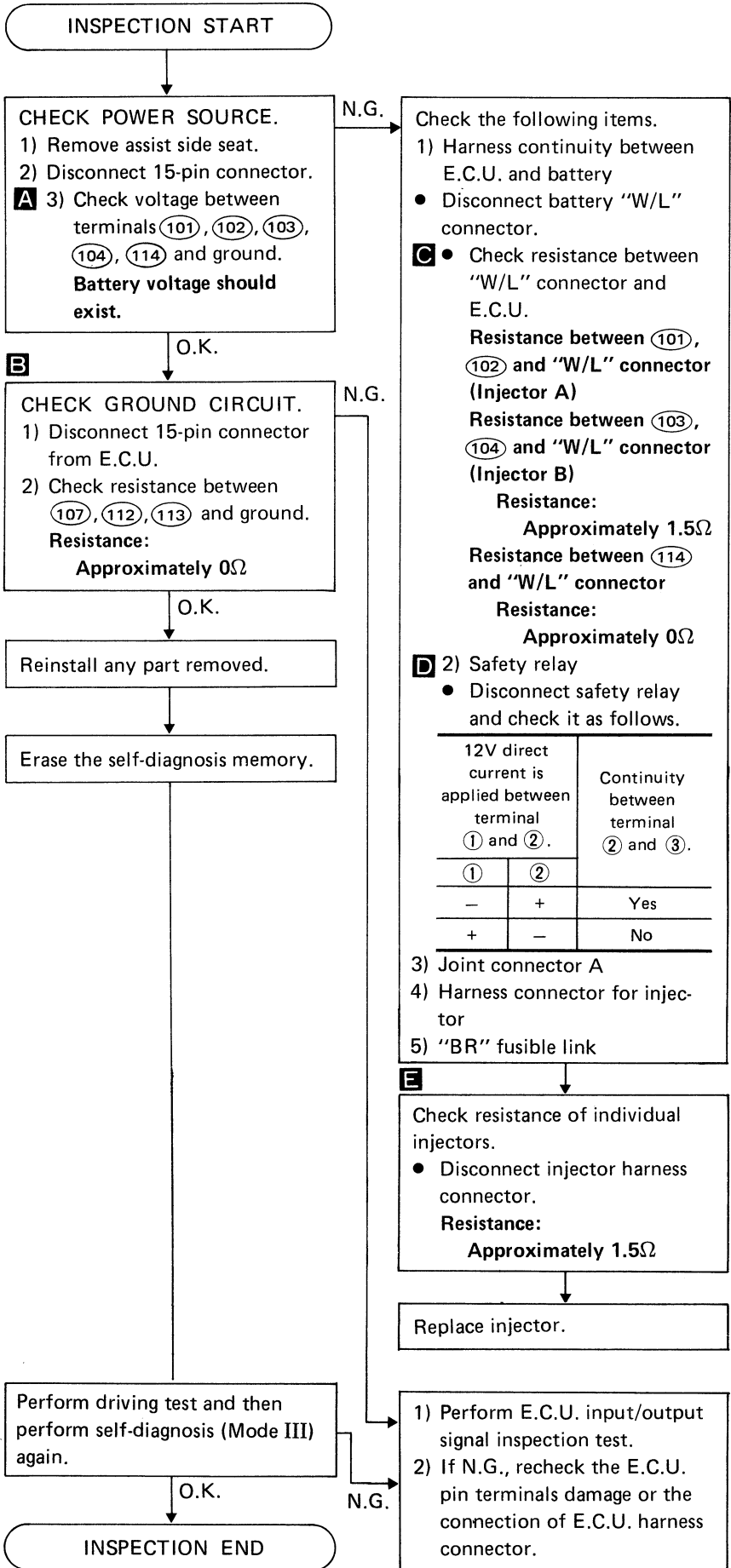
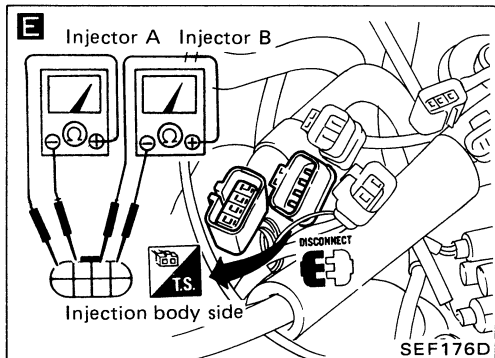
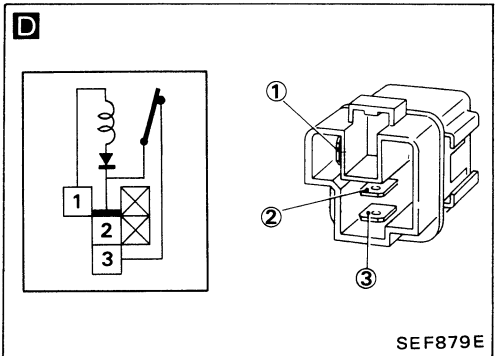
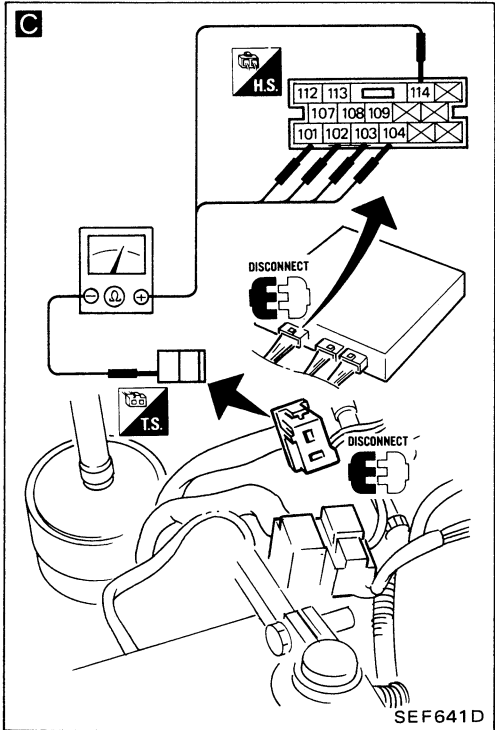
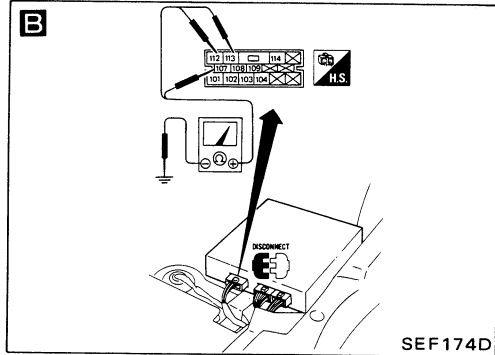

IDLE SWITCH (Switch ON/OFF diagnosis)

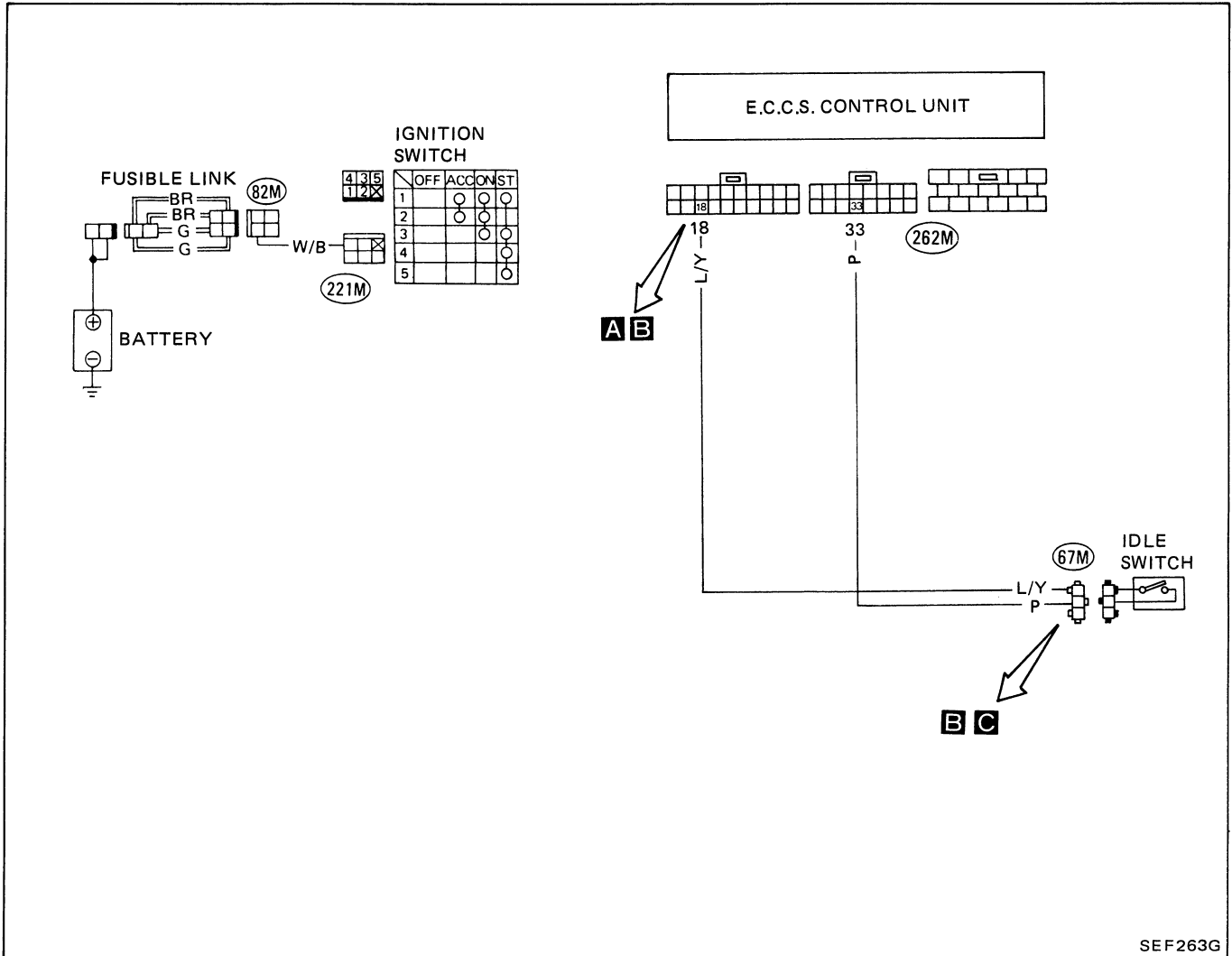

SEF263G

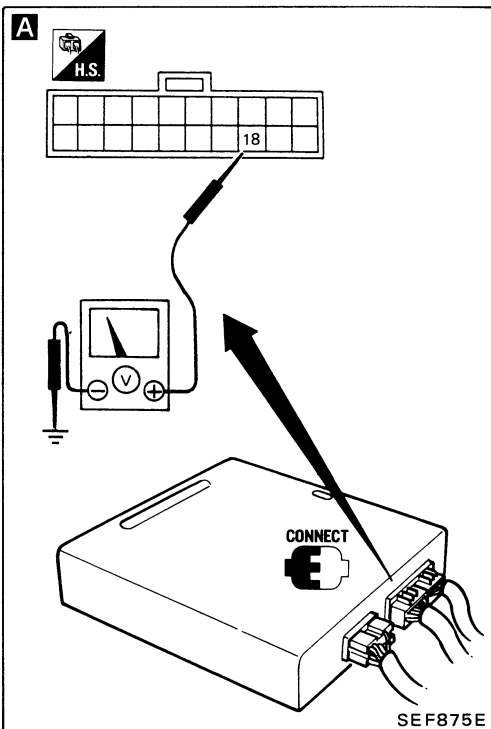

IDLE SWITCH (Switch ON/OFF diagnosis)

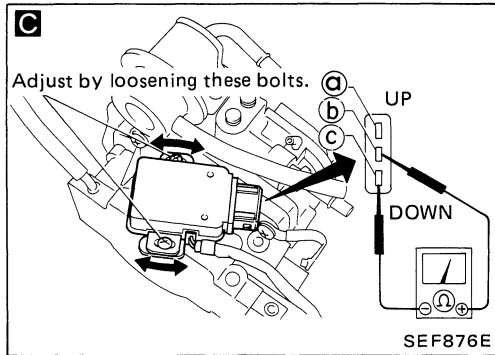
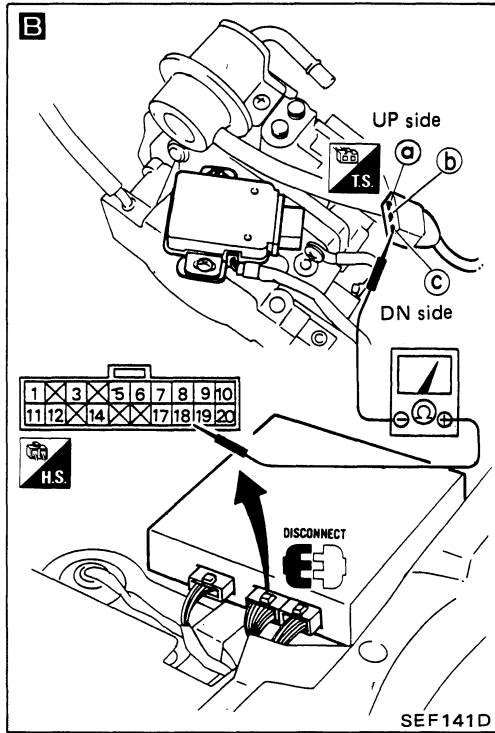

INSPECTION START

A CHECK INPUT SIGNAL.

- 1) Turn ignition switch "ON".
- 2) Check voltage between E.C.U. terminals ⑱ and ground.

Accel. pedal condition	Voltage
Fully closed	Approximately 5.0V
Open	0V

N.G. → Check the following items.

B 1) Harness continuity between E.C.U. and throttle valve switch.

- Disconnect 20-pin connector from E.C.U.
- Disconnect idle switch harness connector.
- Check resistance between E.C.U. terminal ⑱ and terminal ㉓.

Resistance:
Approximately 0Ω

C 2) Continuity of idle switch.

- Disconnect idle switch harness connector.
- Check resistance between terminals ㉑ and ㉒ when idle switch closes fully.

Resistance:
Approximately 0Ω

- Check resistance between terminals ㉒ and ㉓ when idle switch opens fully.

Resistance:
Approximately 0Ω

3) Power source and ground circuit for E.C.U.
(See page EF & EC-140.)

O.K. ↓

Perform switch ON/OFF diagnosis (Mode-IV).

N.G. →

- 1) Perform E.C.U. input/output signal inspection test.
- 2) If N.G., recheck the E.C.U. pin terminals damage or the connection of E.C.U. harness connector.

O.K. ↓

INSPECTION END

STARTER SWITCH (Switch ON/OFF diagnosis)

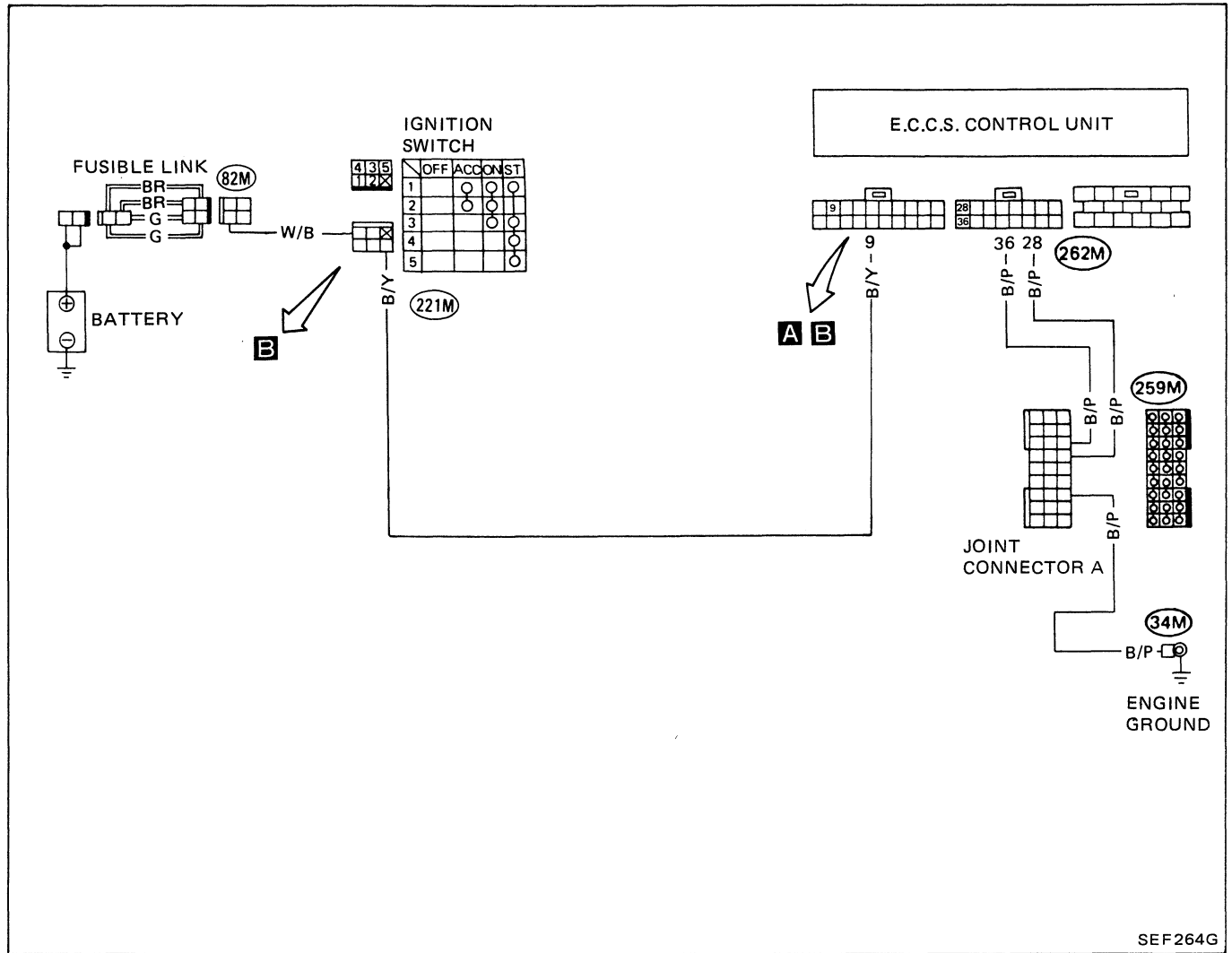

SEF264G

STARTER SWITCH (Switch ON/OFF diagnosis)

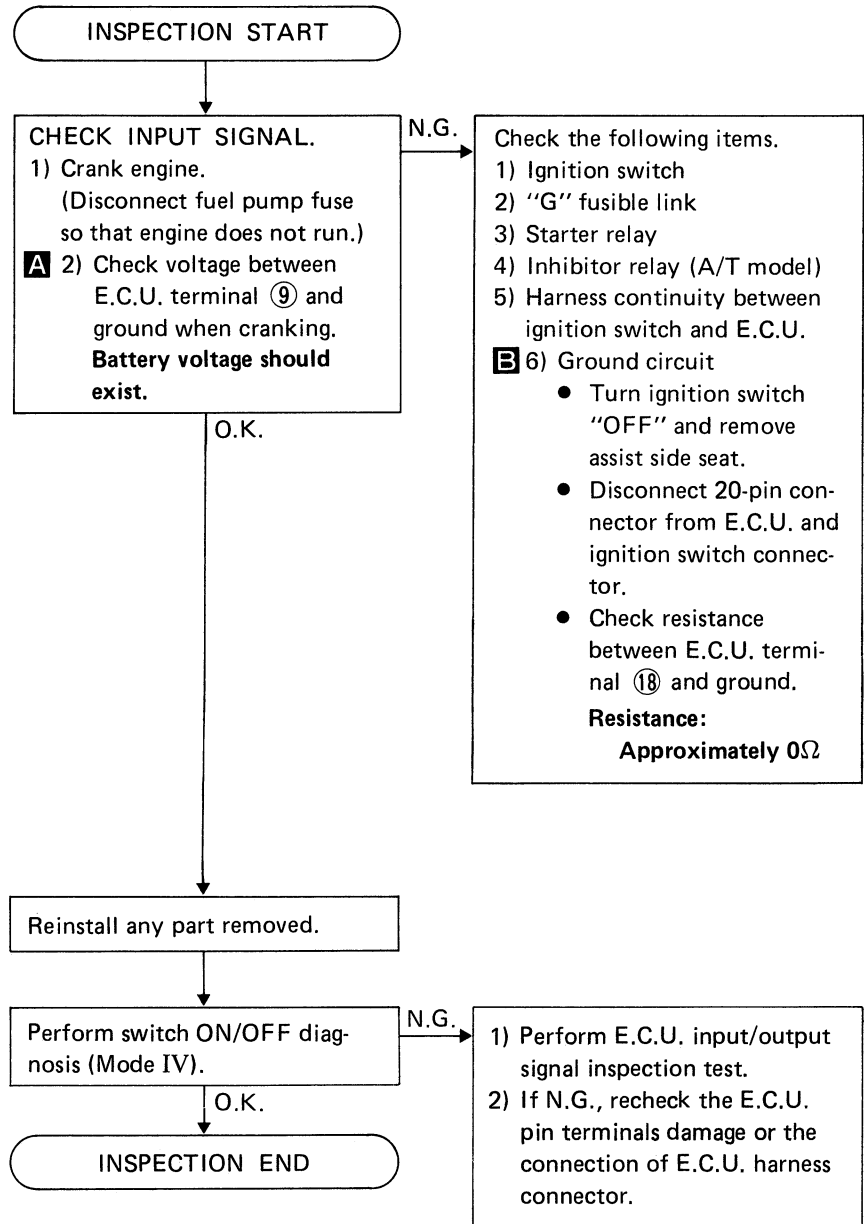
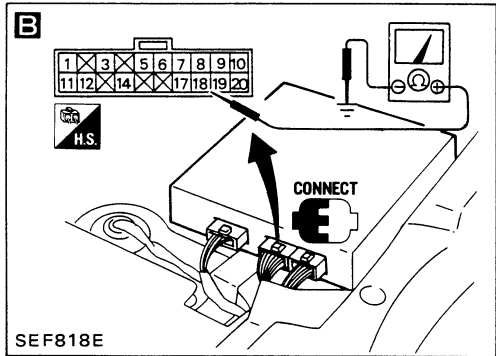
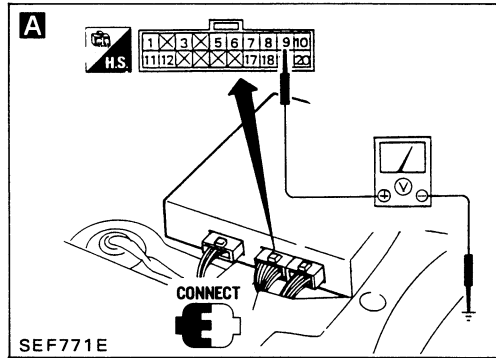

VEHICLE SPEED SENSOR (Switch ON/OFF diagnosis); A/T MODEL ONLY

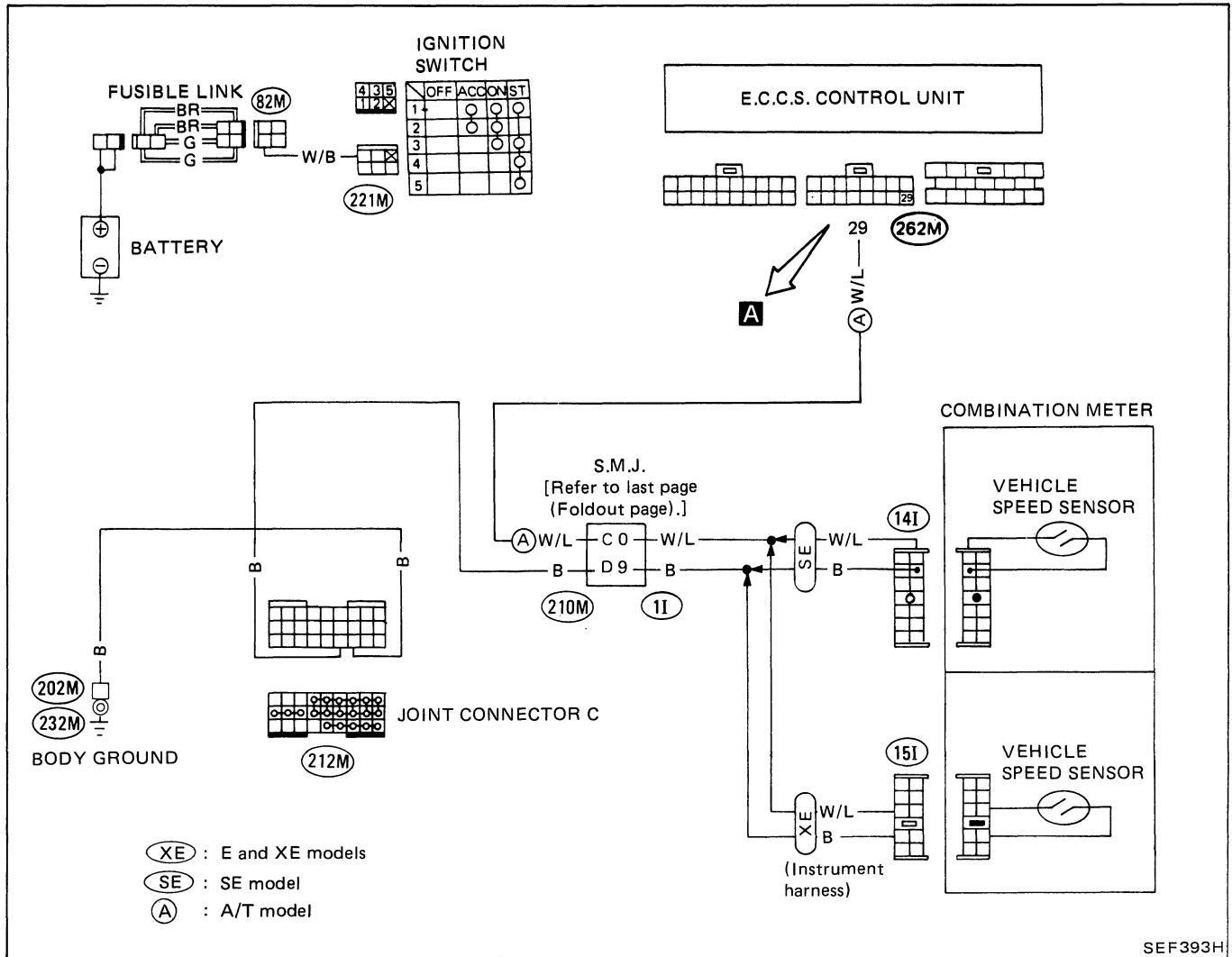

SEF393H

VEHICLE SPEED SENSOR (Switch ON/OFF diagnosis); A/T MODEL ONLY

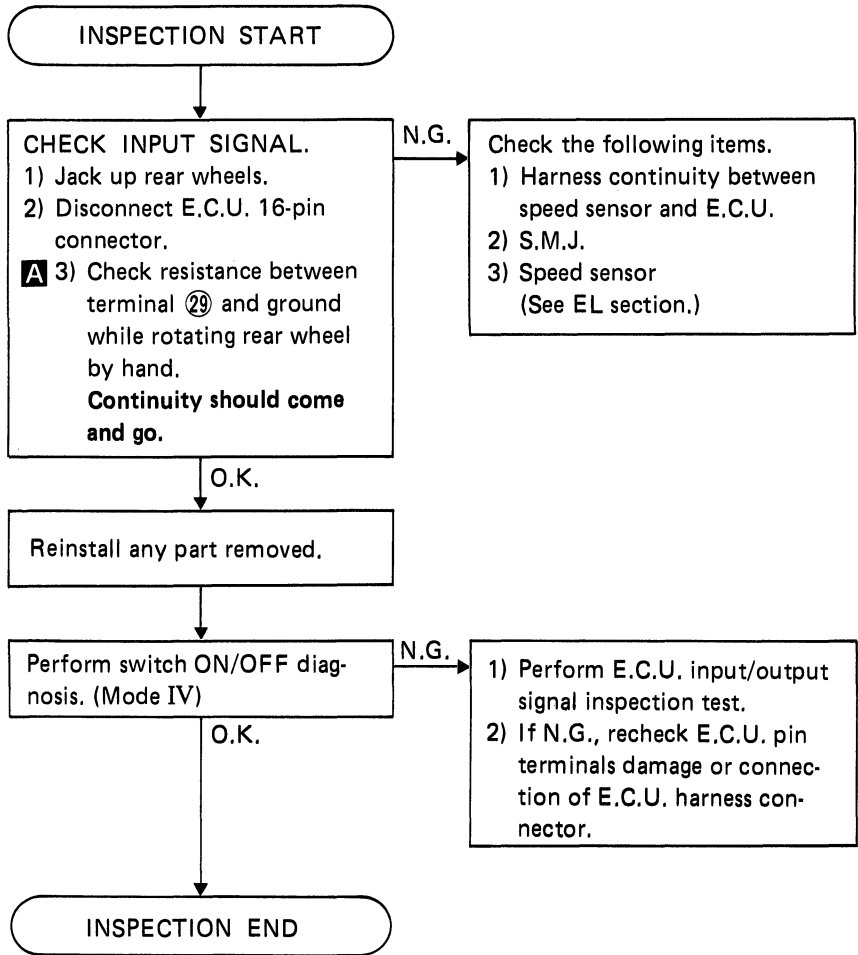
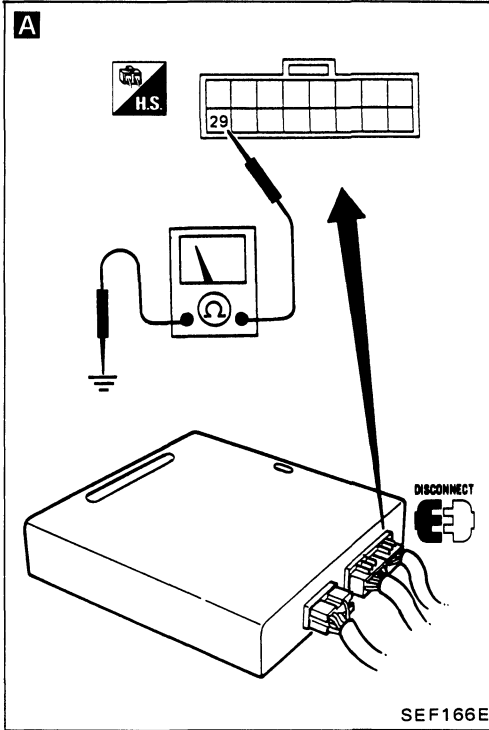
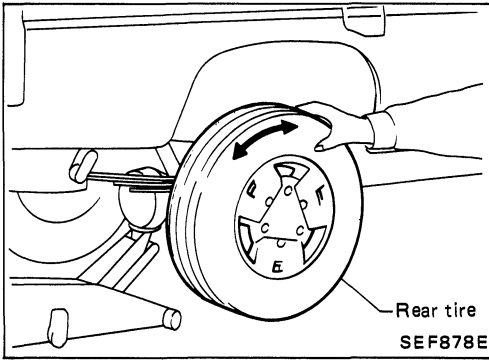

NEUTRAL/CLUTCH/INHIBITOR SWITCH (Not self-diagnostic item)

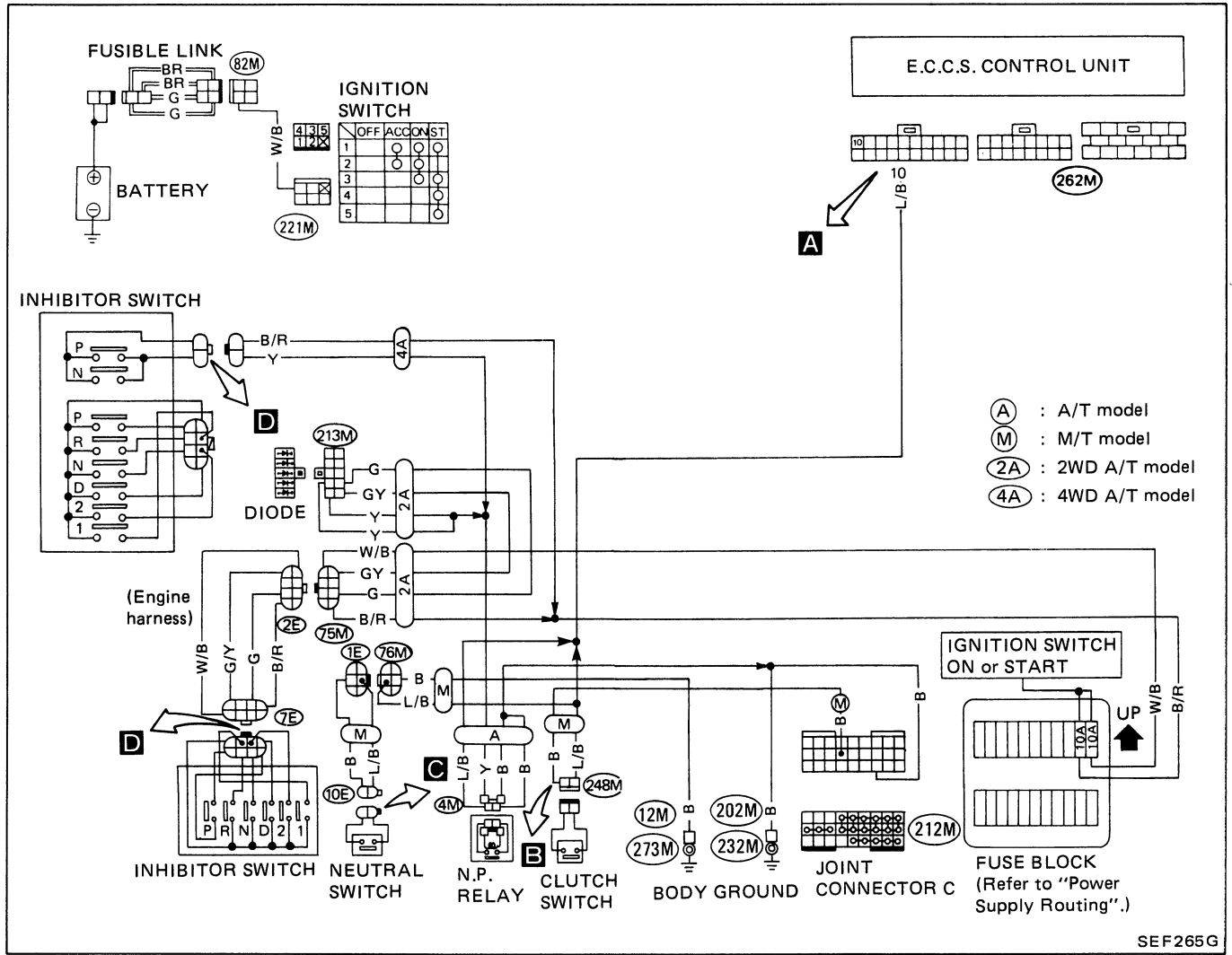

SEF265G

NEUTRAL/CLUTCH/INHIBITOR SWITCH (Not self-diagnostic item)

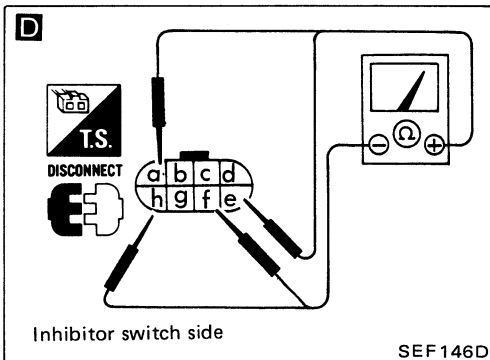
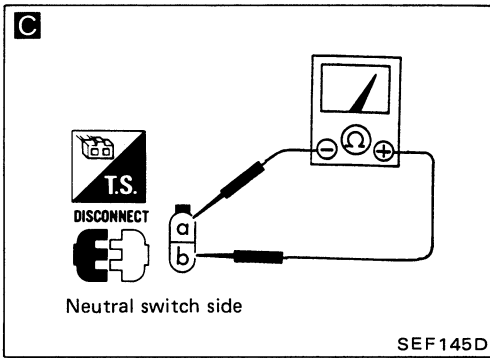
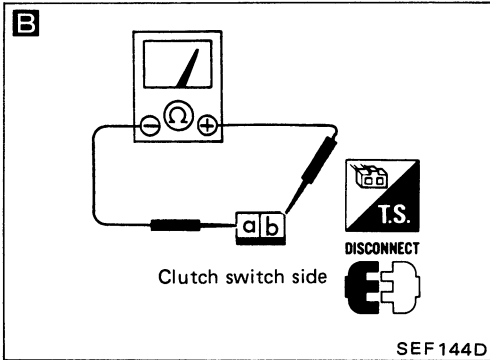
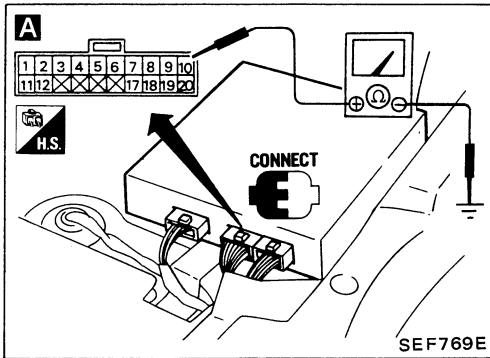

INSPECTION START

A

CHECK INPUT SIGNAL.
Check continuity between E.C.U. connector terminal ⑩ and ground.
Continuity should be as shown below.

M/T model

Gear position \ Clutch condition	Engaged	Dis-engaged
	Neutral	0Ω
Others	∞Ω	0Ω

A/T model

• Turn ignition switch "ON".

Gear position	Resistance
N or P	0Ω
Others	∞Ω

O.K.

Reinstall any part removed.

INSPECTION END

N.G. → Check the following items.

- M/T model**
- 1) Harness continuity between E.C.U. and ground
 - B** 2) Continuity of clutch switch
 - Disconnect harness connector for clutch switch.
 - Depress clutch pedal.
 - Check continuity between terminals ㉑ and ㉒.
Continuity should exist.
If not, replace clutch switch.
 - C** 3) Continuity of neutral switch
 - Disconnect harness connector for neutral switch.
 - Shift manual transmission lever to neutral.
 - Check continuity between terminals ㉑ and ㉒.
Continuity should exist.
If not, replace neutral switch.
 - 4) Joint connector B
- A/T model**
- 1) Turn ignition switch "OFF".
 - 2) Harness continuity between E.C.U. and ground, ignition switch and ground
 - D** 3) Continuity of inhibitor switch
 - Disconnect harness connector for inhibitor switch.
 - Shift automatic transmission lever to "P" or "N".
 - Check continuity between terminals ㉑ and ㉒, ㉓ and ㉔.
Continuity should exist.
㉑ and ㉒ : "N",
㉓ and ㉔ : "P"
If not, replace inhibitor switch.
 - 4) N.P. relay
 - 5) Ignition switch
 - 6) Fuse

LOAD SIGNAL (Not self-diagnostic item)

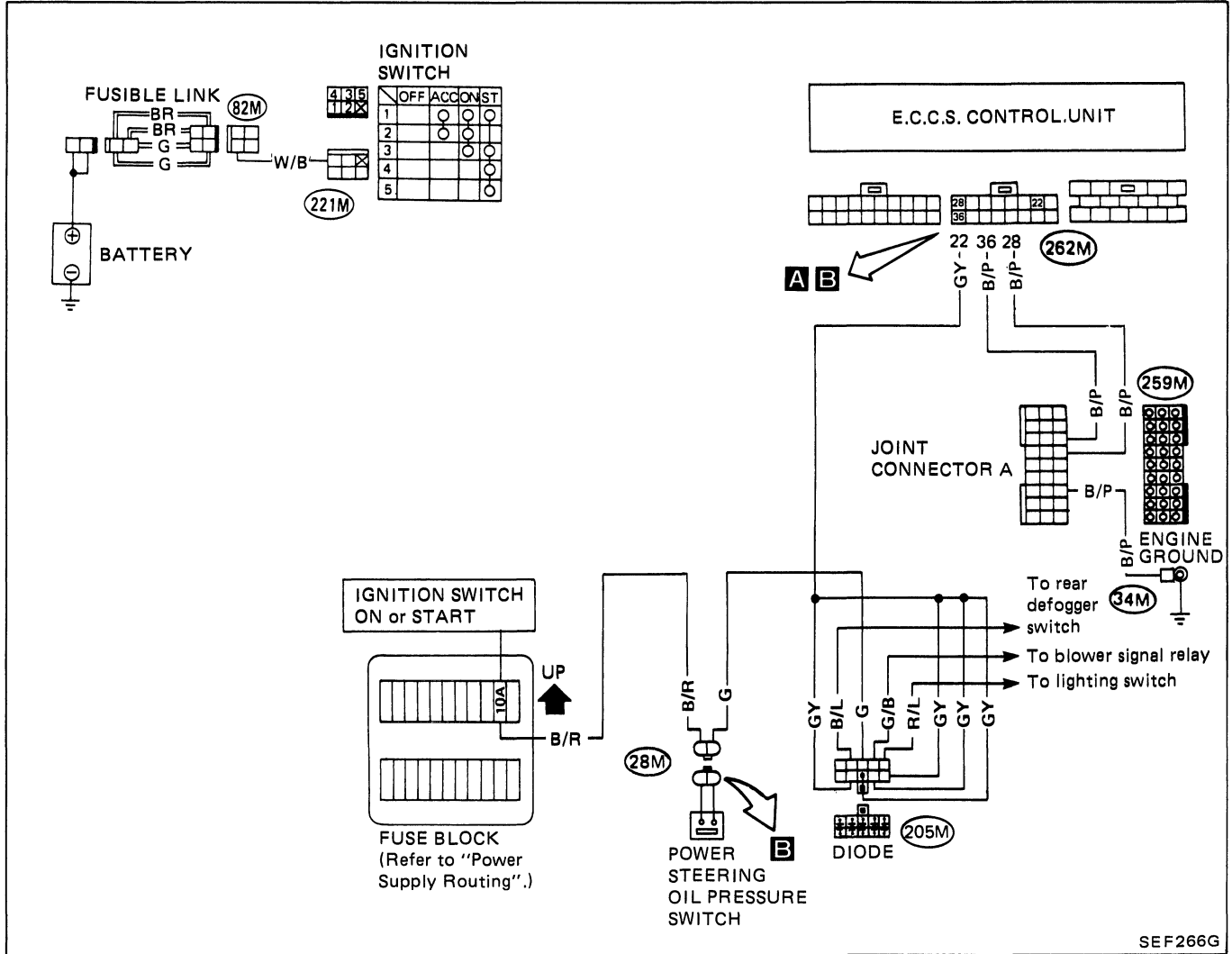

SEF266G

LOAD SIGNAL (Not self-diagnostic item)

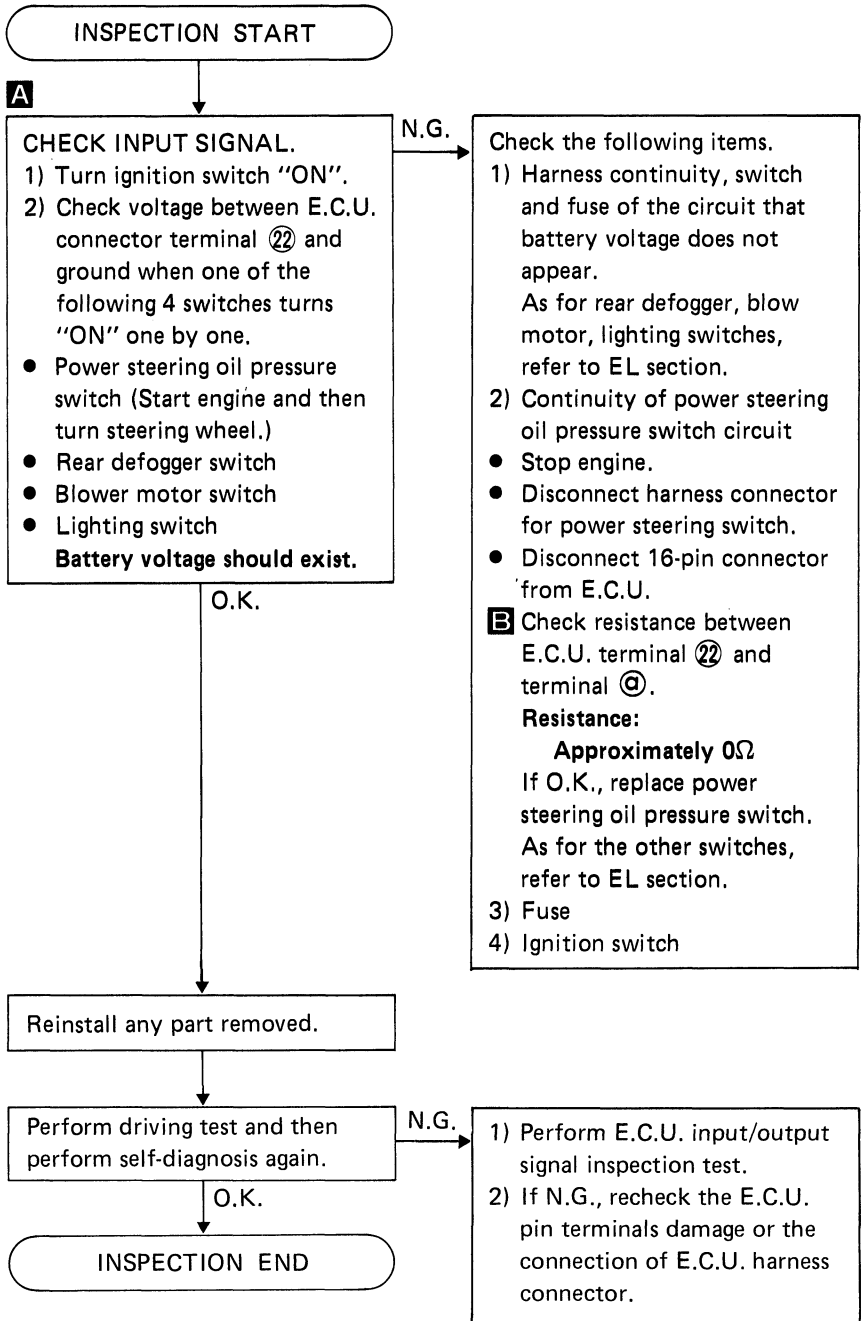
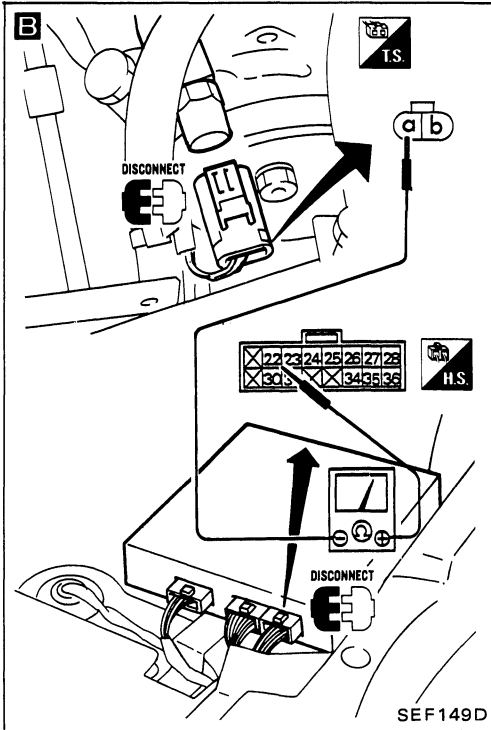
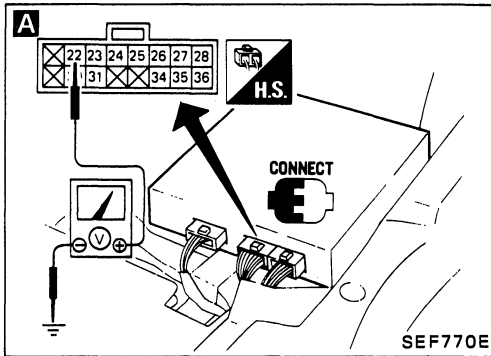

MIXTURE HEATER (Not self-diagnostic item)

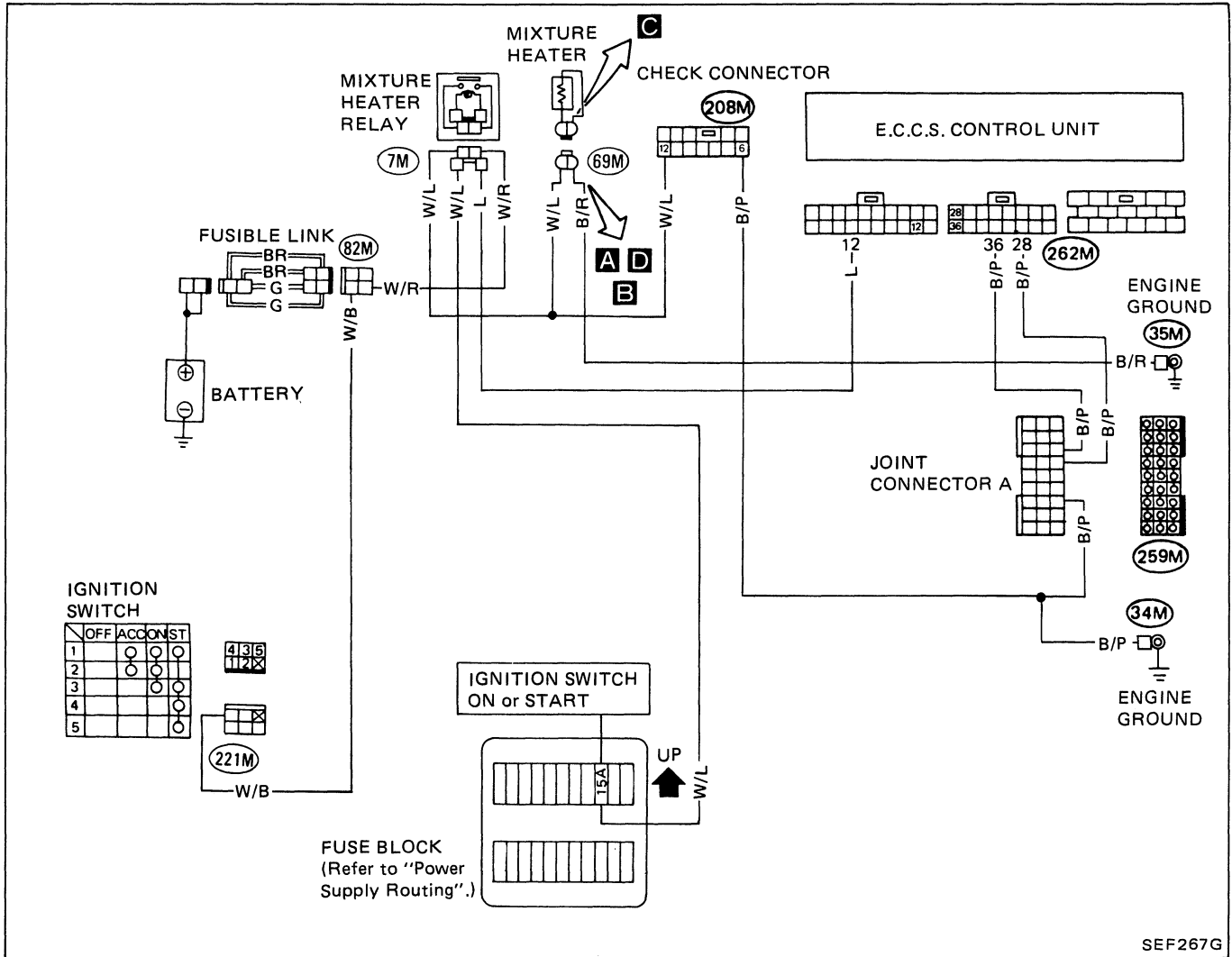

SEF267G

MIXTURE HEATER (Not self-diagnostic item)

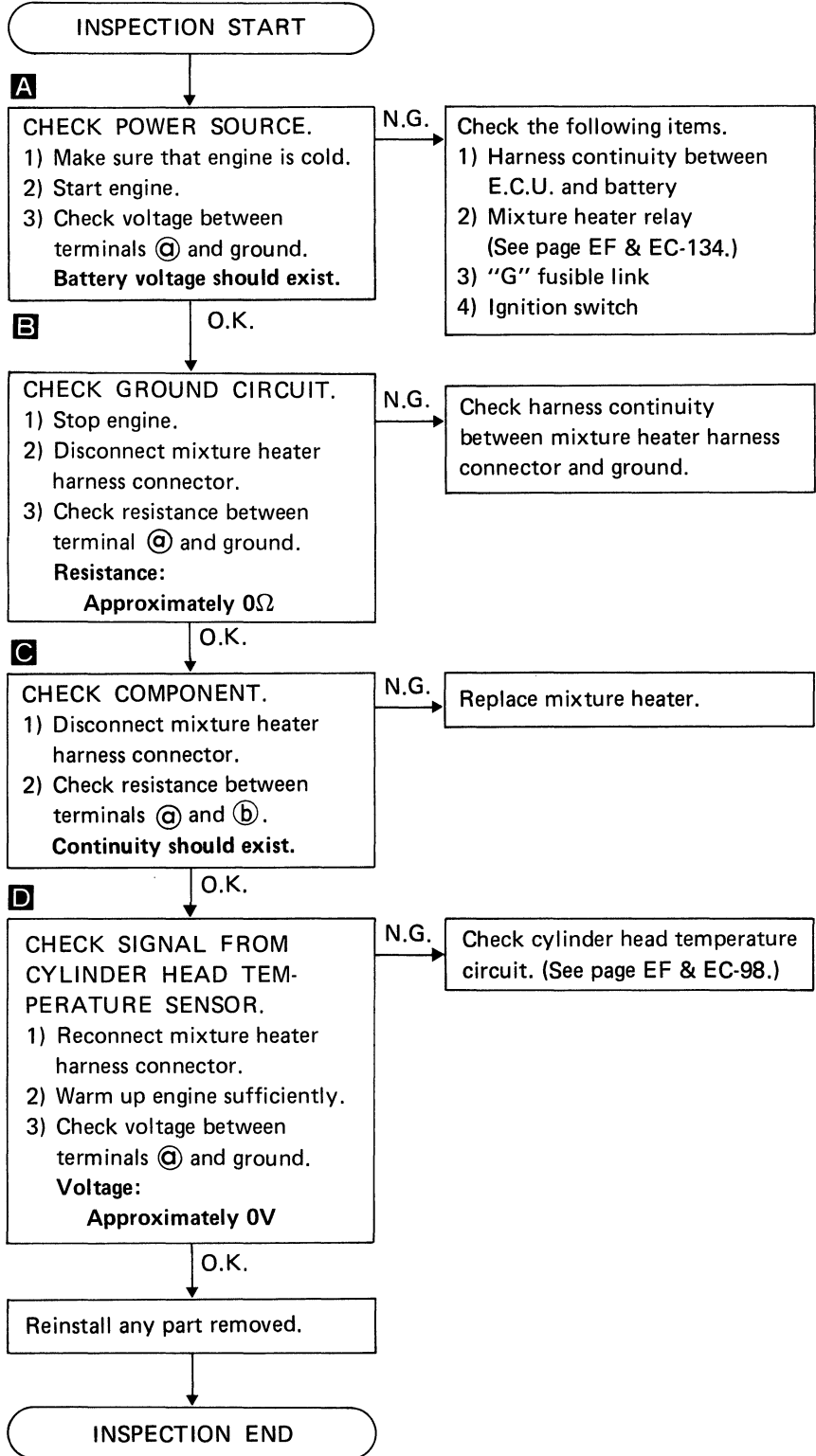
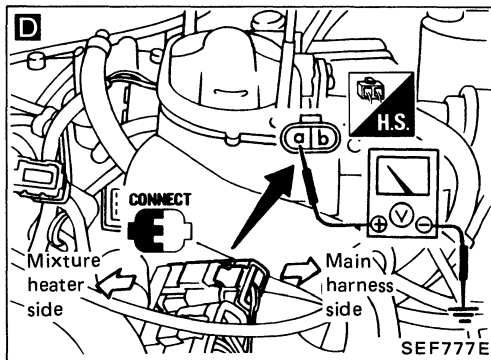
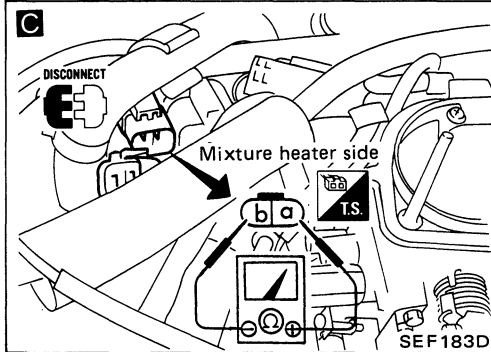
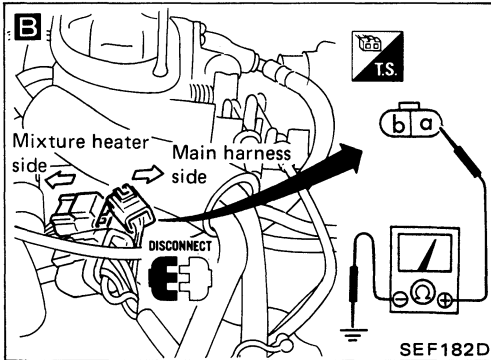
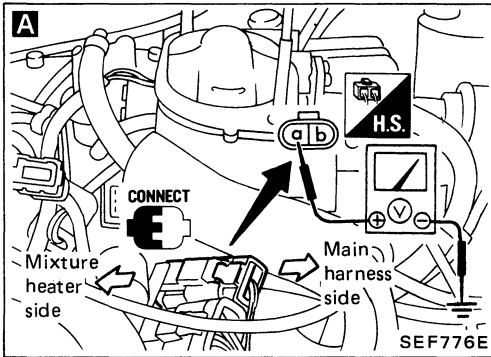

MIXTURE HEATER RELAY (Not self-diagnostic item)

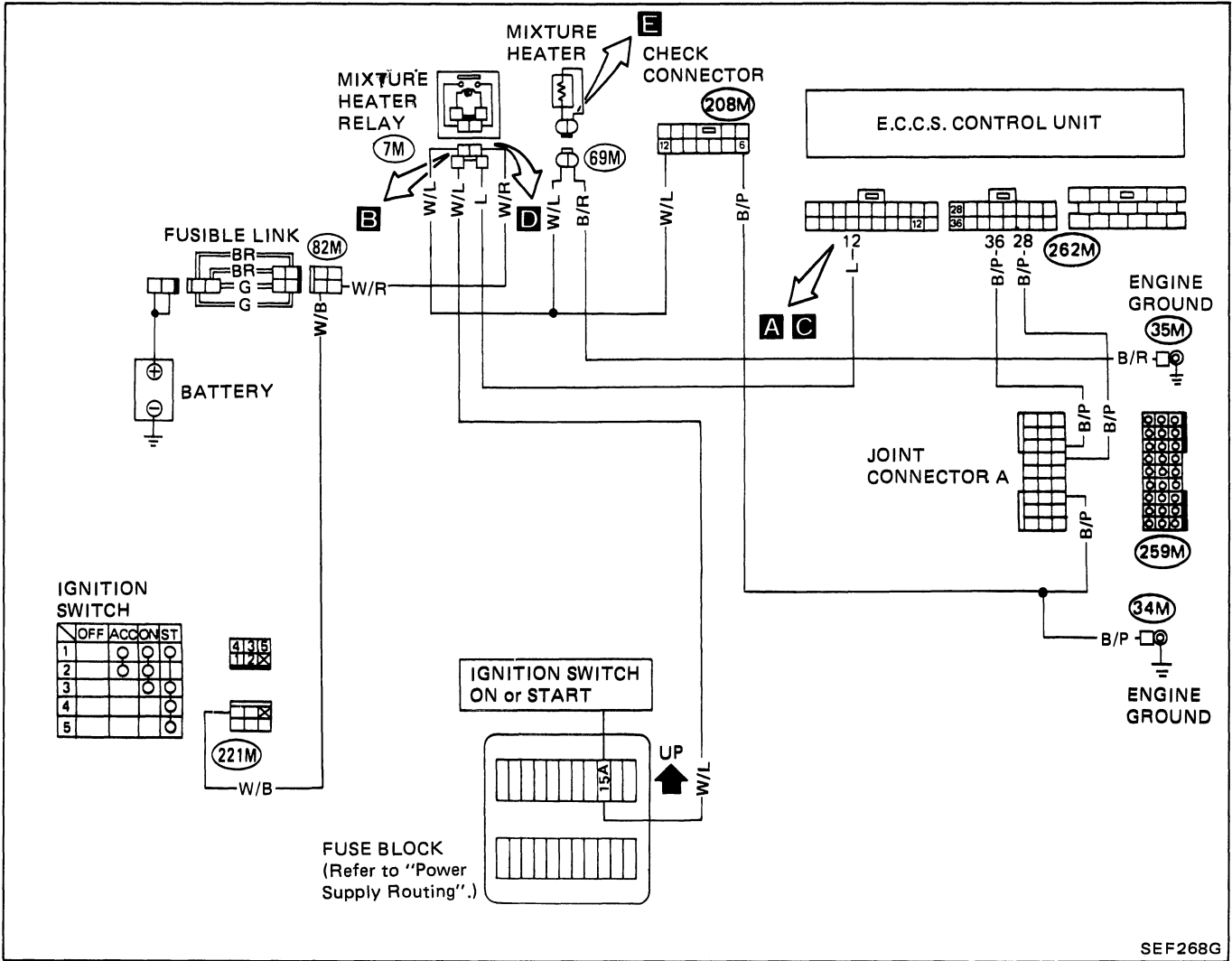

SEF268G

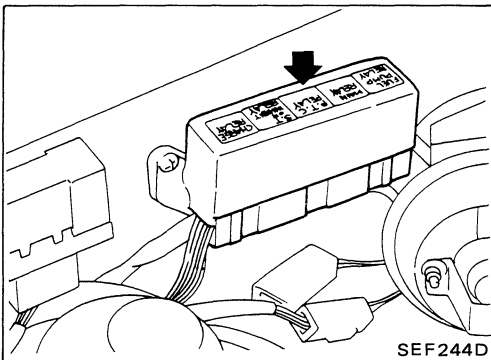

Mixture heater relay location

MIXTURE HEATER RELAY (Not self-diagnostic item)

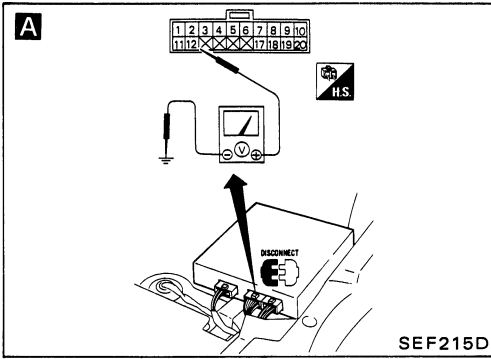

- 1) Turn ignition switch "OFF".
- 2) Disconnect 20-pin connector from E.C.U.
- 3) Turn ignition switch "ON".
- A** 4) Check voltage between terminal ⑫ and ground. **Battery voltage should exist.**

- N.G.
- 1) Turn ignition switch "OFF".
 - 2) Remove mixture heater relay.
 - B** 3) Connect terminals ① and ② with a suitable jumper wire.
 - 4) Turn ignition switch "ON".
 - A** 5) Recheck voltage between terminal ⑫ and ground. **Battery voltage should exist.**

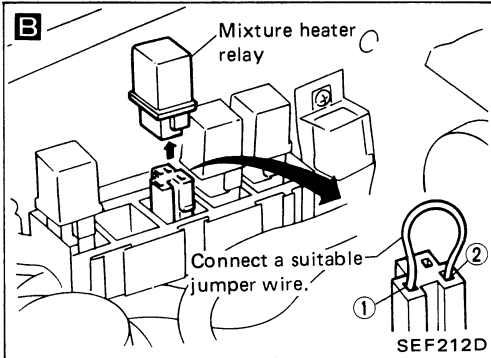

- O.K.
- 1) Turn ignition switch "OFF".
 - C** 2) Connect terminal ⑫ to ground using a suitable jumper wire.
 - 3) Turn ignition switch "ON".
 - E** 4) Check voltage between terminal ⑥ at mixture heater harness connector and ground. **Battery voltage should exist.**

- O.K.
- N.G.
- Replace mixture heater relay.

Check harness continuity between mixture heater relay and battery.

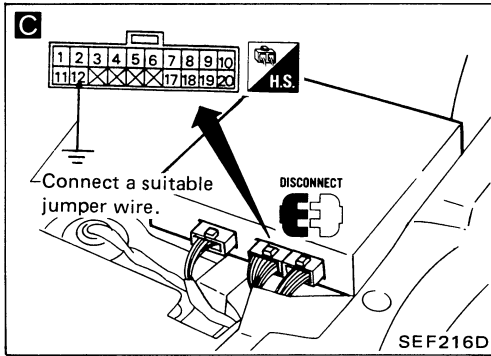

- N.G.
- 1) Turn ignition switch "OFF".
 - 2) Remove mixture heater relay.
 - D** 3) Connect terminals ③ and ④ using a suitable jumper wire.
 - 4) Turn ignition switch "ON".
 - E** 5) Recheck voltage between terminal ⑥ at mixture heater harness connector and ground. **Battery voltage should exist.**

- O.K.
- N.G.
- 1) Turn ignition switch "OFF".
 - 2) Remove mixture heater relay.
 - D** 3) Connect terminals ③ and ④ using a suitable jumper wire.
 - 4) Turn ignition switch "ON".
 - E** 5) Recheck voltage between terminal ⑥ at mixture heater harness connector and ground. **Battery voltage should exist.**

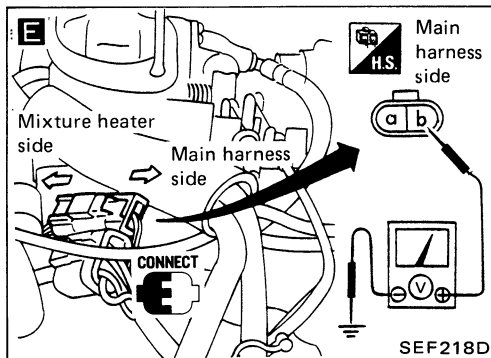
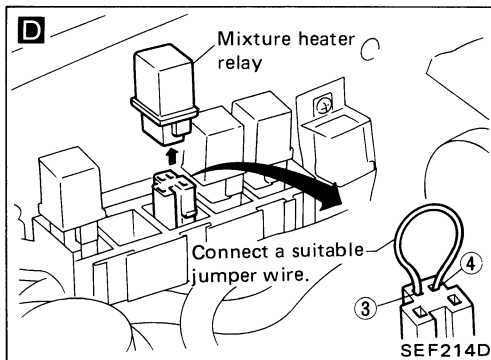

FUEL PUMP (Not self-diagnostic item)

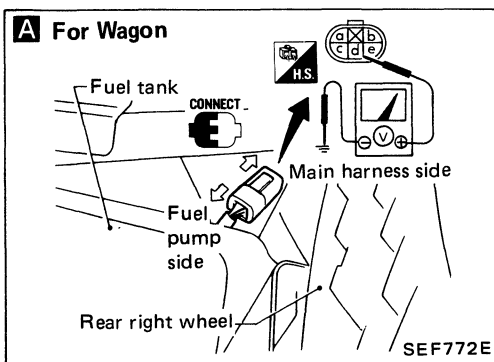
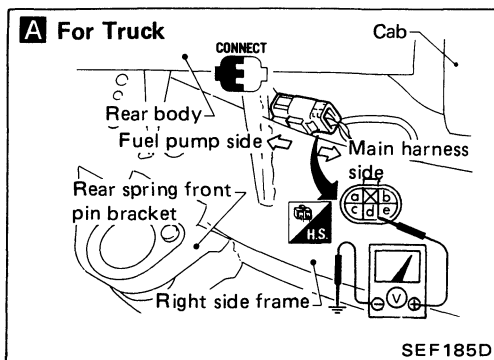
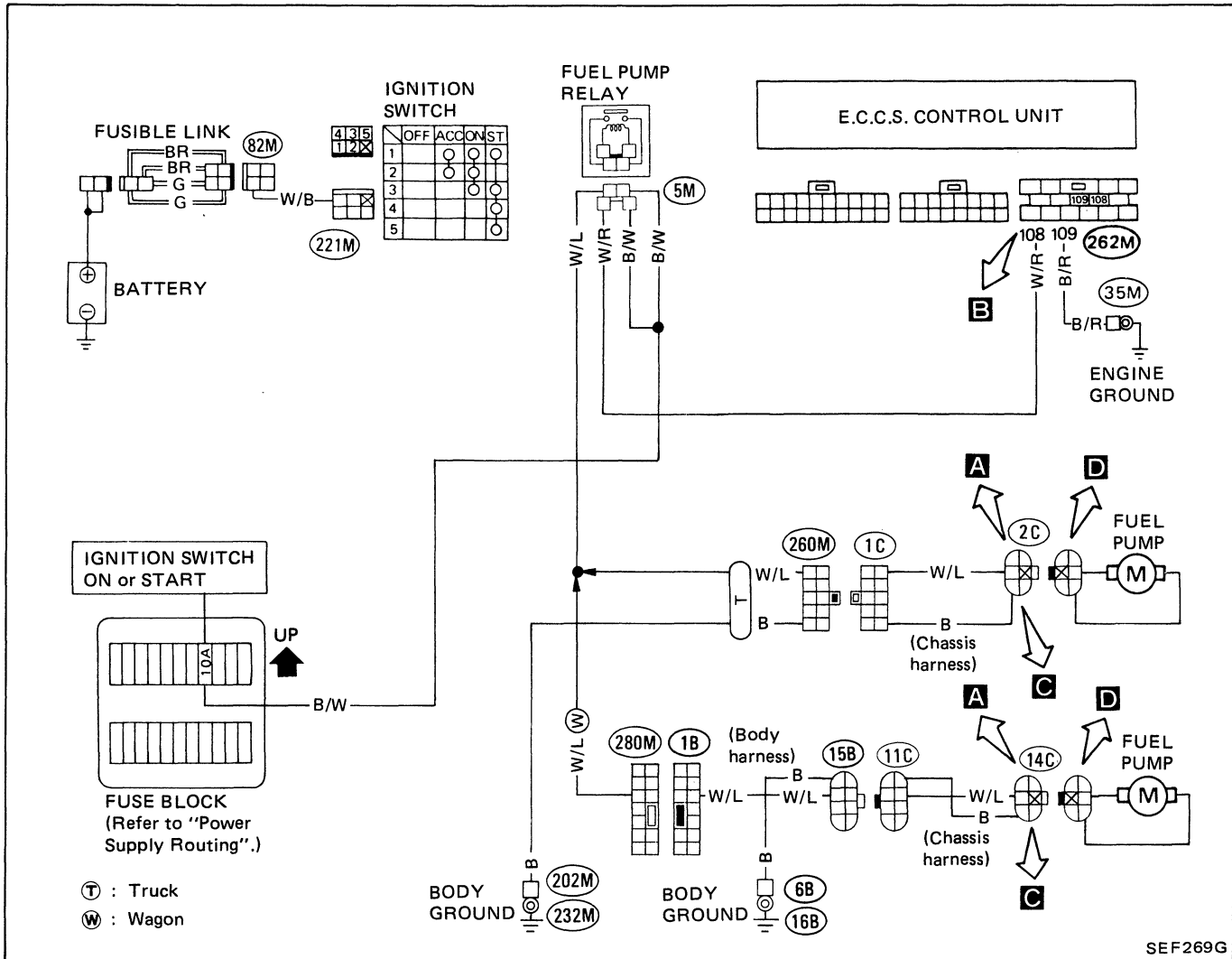

FUEL PUMP (Not self-diagnostic item)

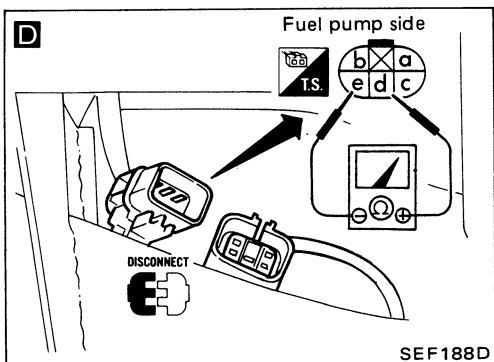
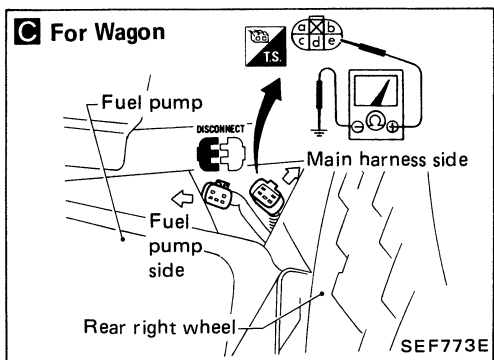
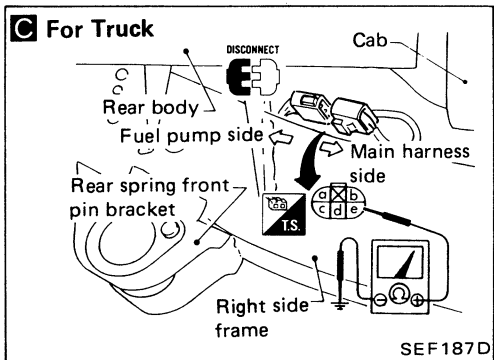
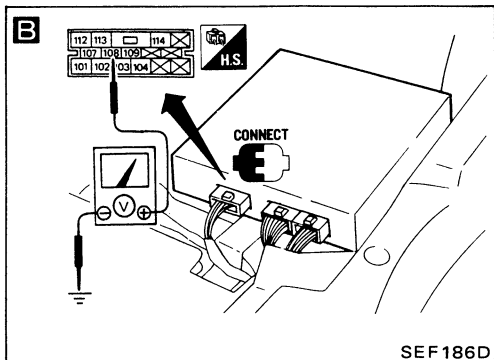

```

    graph TD
        Start([INSPECTION START]) --> A[CHECK POWER SOURCE.  
1) Turn ignition switch "ON".  
2) Check voltage between terminal d and ground.  
Battery voltage should exist for 5 seconds after turning ignition switch "ON".]
        A -- N.G. --> A_NG[Check the following items.  
1) Harness continuity between fuel pump and ground  
2) Fuel pump relay (See page EF & EC-138.)  
3) "G" fusible link  
4) Power source to E.C.U.  
B • Turn ignition switch "OFF".  
• Remove assist side seat.  
• Turn ignition switch "ON".  
• Check voltage between terminal 108 and ground.  
Battery voltage should appear in 5 seconds after turning ignition switch "ON".]
        A -- O.K. --> C[CHECK GROUND CIRCUIT.  
1) Turn ignition switch "OFF".  
2) Disconnect fuel pump harness connector.  
3) Check resistance between terminal e and ground.  
Resistance:  
Approximately 0Ω]
        C -- N.G. --> C_NG[Check harness connection between fuel pump harness connector and ground.]
        C -- O.K. --> D[CHECK COMPONENT.  
1) Disconnect fuel pump harness connector.  
2) Check resistance between terminals d and e.  
Continuity should exist.]
        D -- N.G. --> D_NG[Replace fuel pump.]
        D -- O.K. --> E[Check crank angle sensor circuit.  
(See page EF & EC-94.)]
        E --> F[Reinstall any part removed.]
        F --> End([INSPECTION END])
    
```

FUEL PUMP RELAY (Not self-diagnostic item)

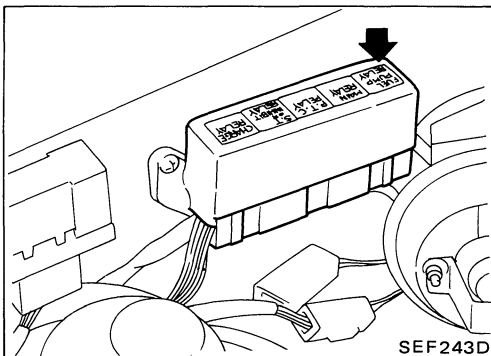
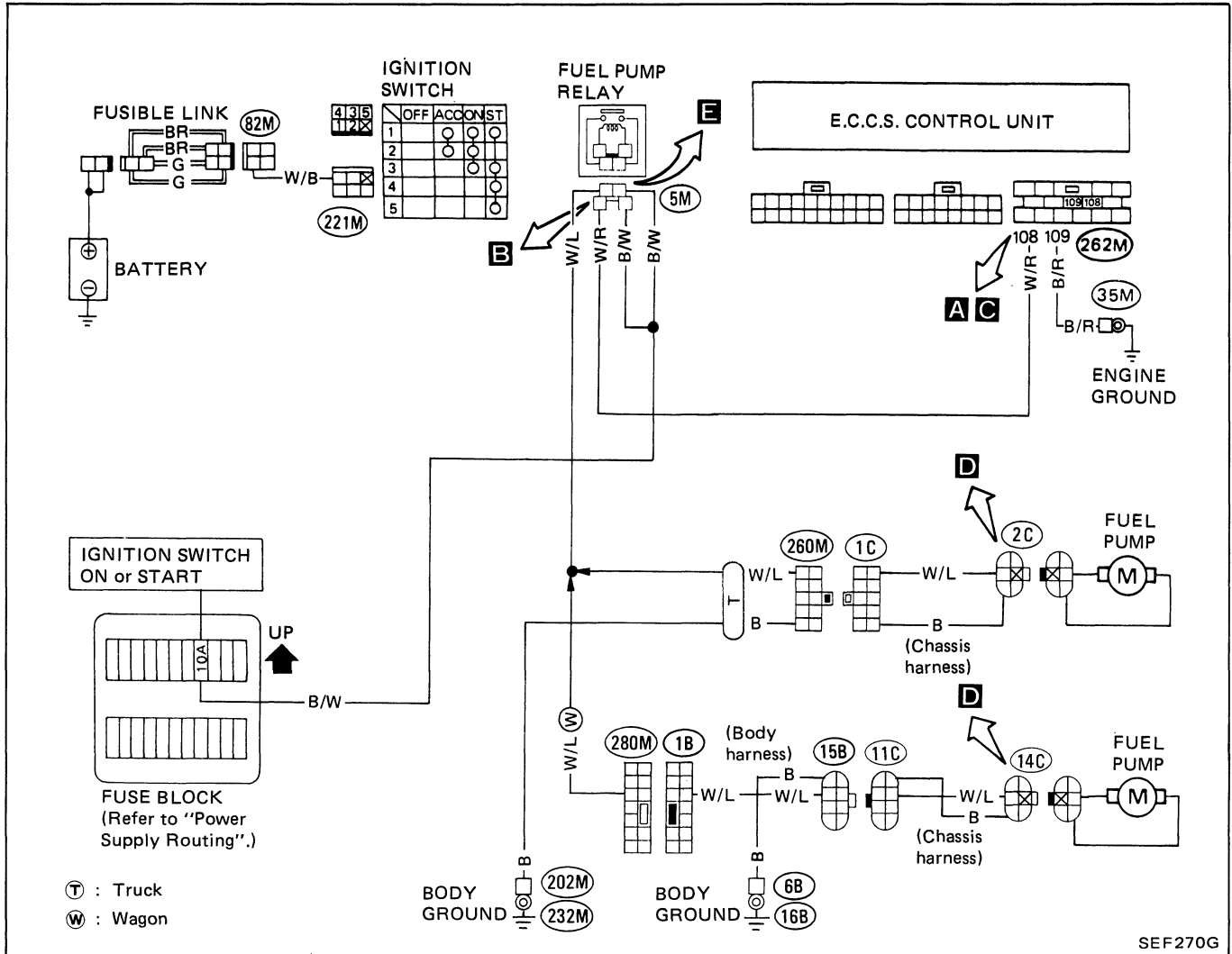

Fuel pump relay location

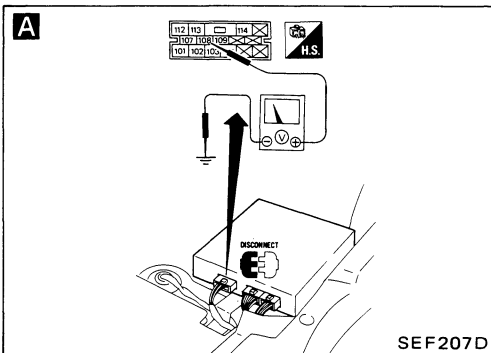

FUEL PUMP RELAY (Not self-diagnostic item)

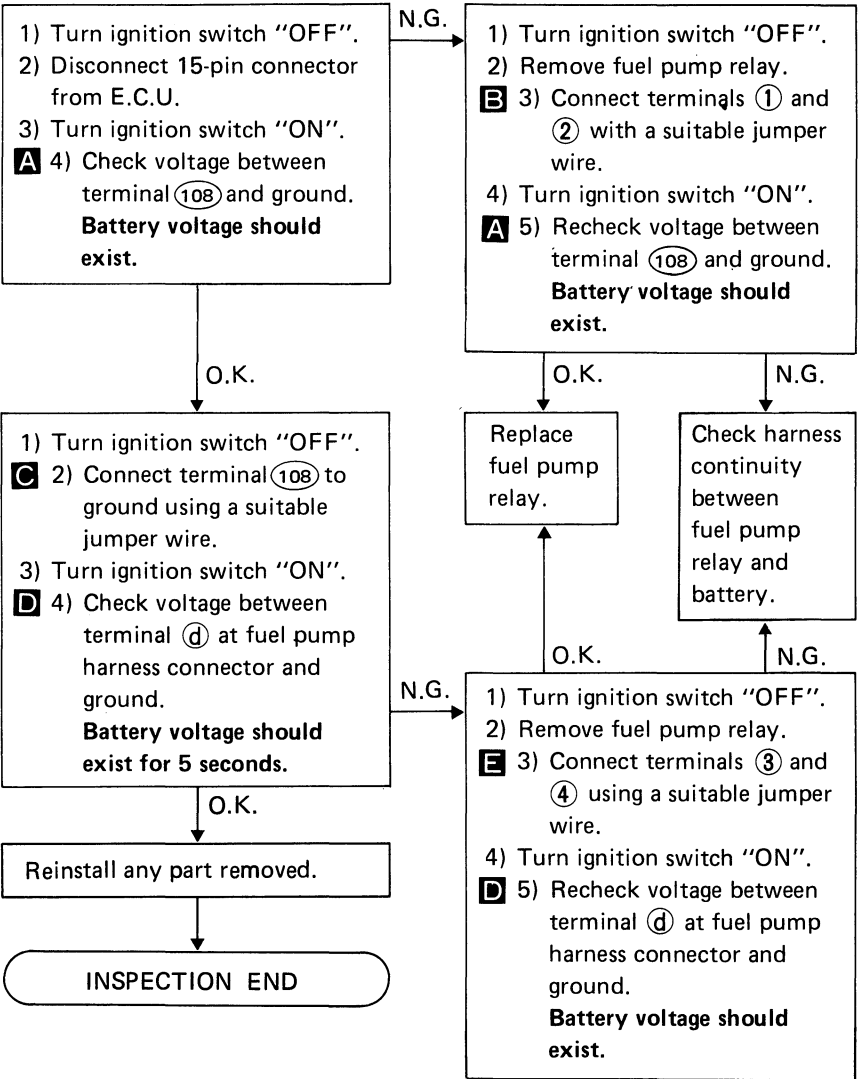
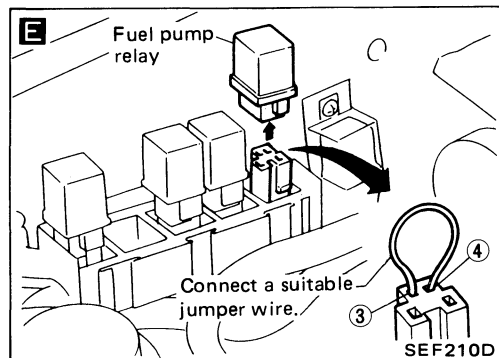
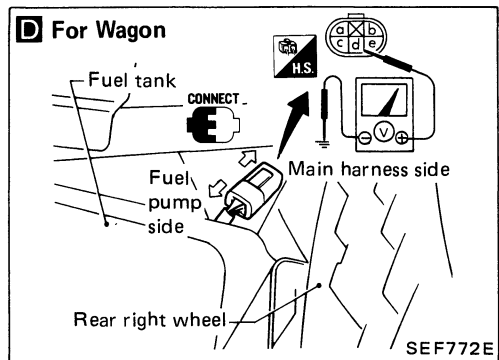
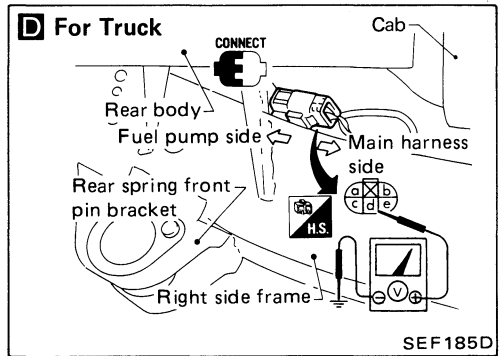
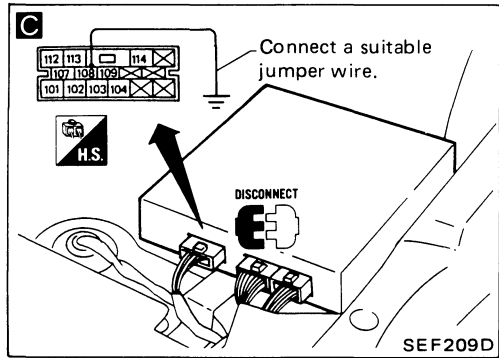
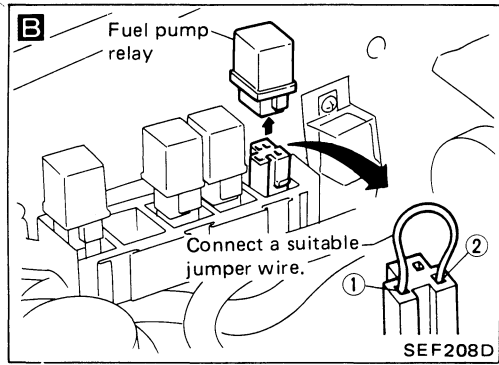

POWER SOURCE FOR E.C.U. & GROUND CIRCUIT FOR E.C.U. (Not self-diagnostic item)

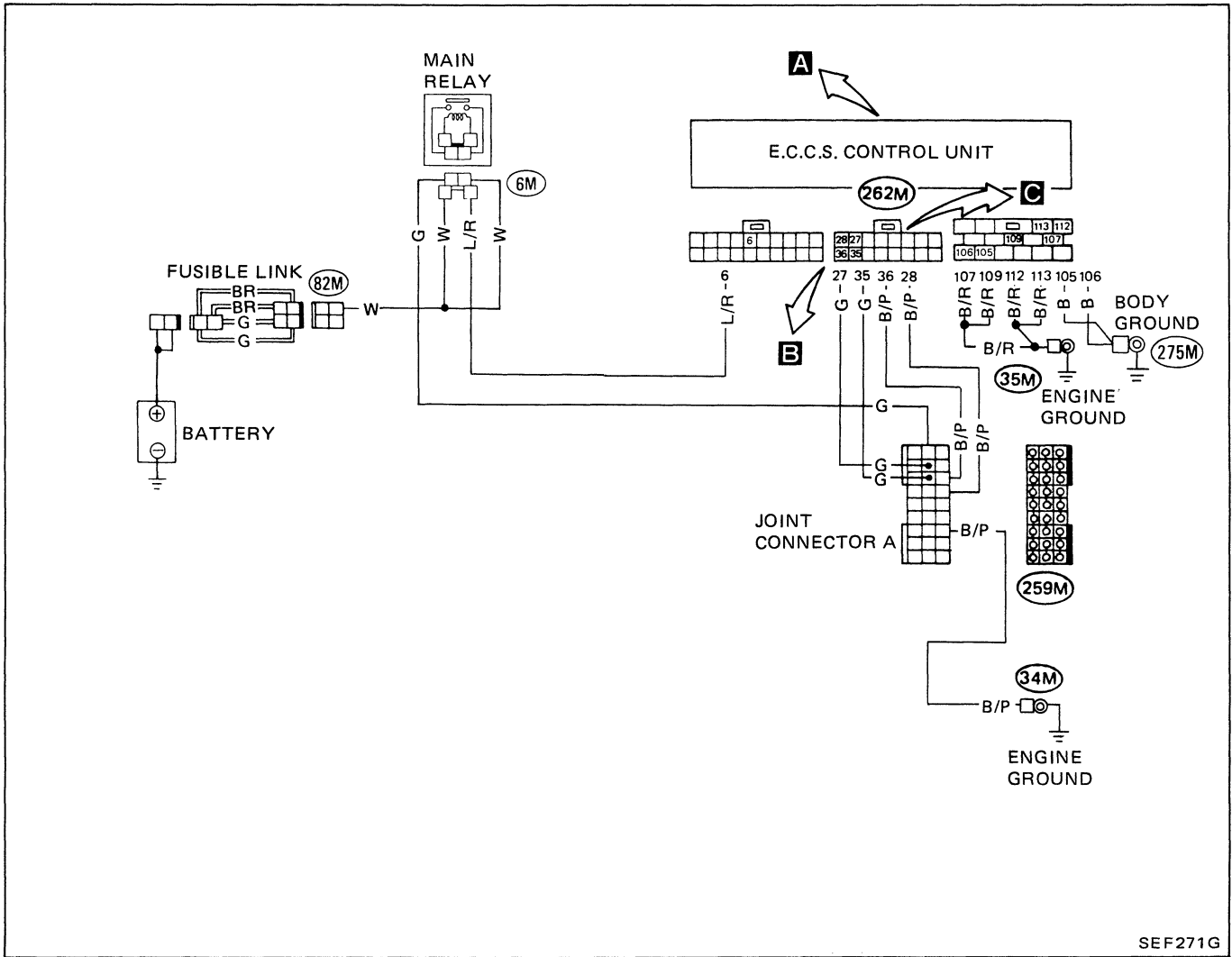

SEF271G

POWER SOURCE FOR E.C.U. & GROUND CIRCUIT FOR E.C.U. (Not self-diagnostic item)

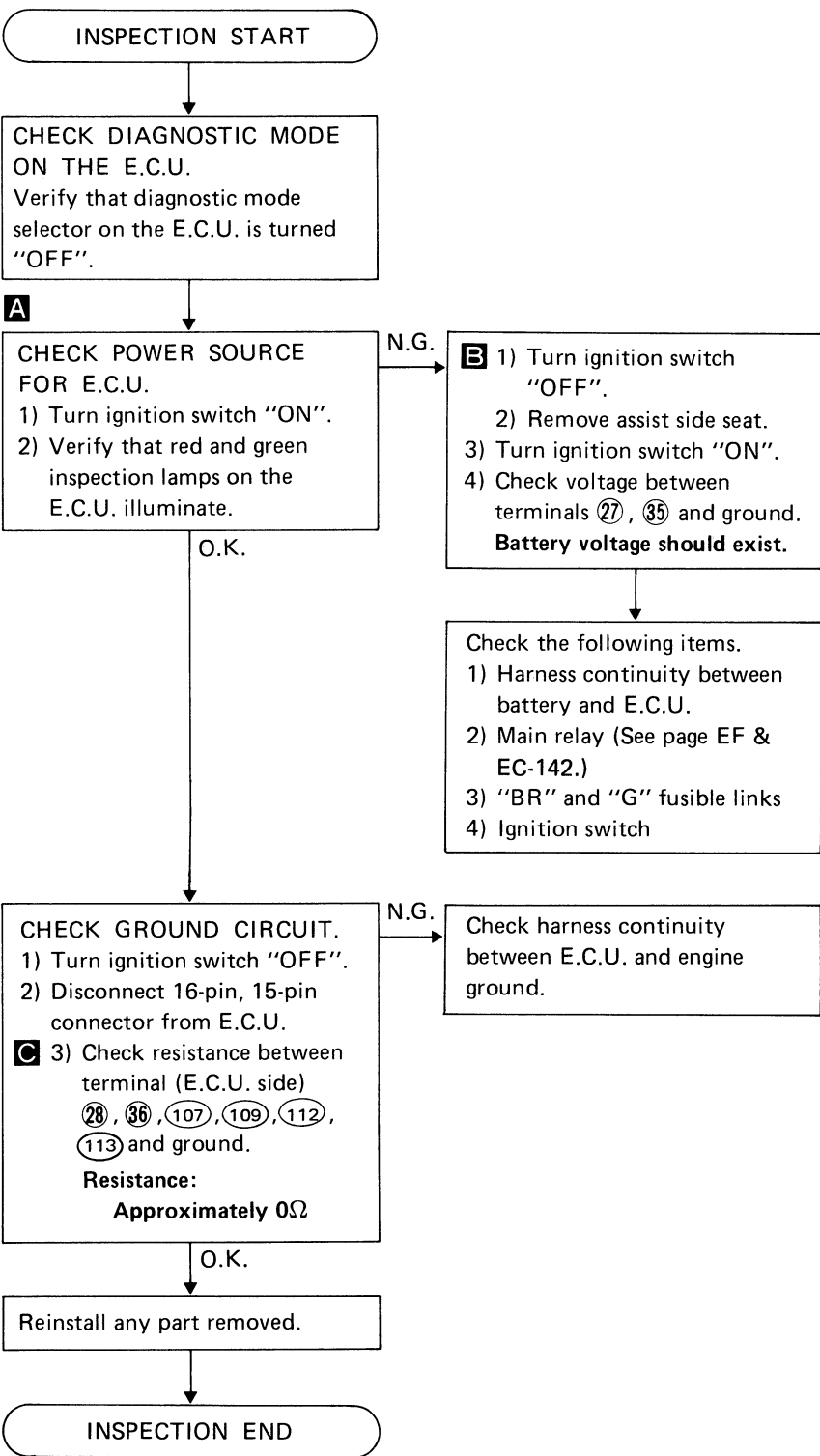
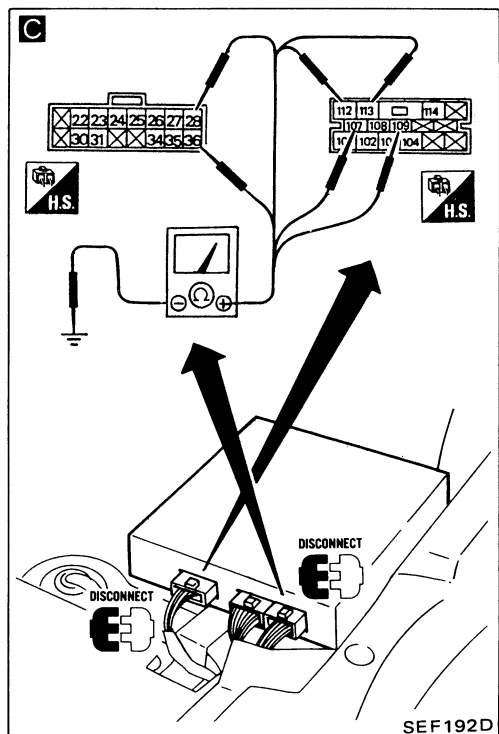
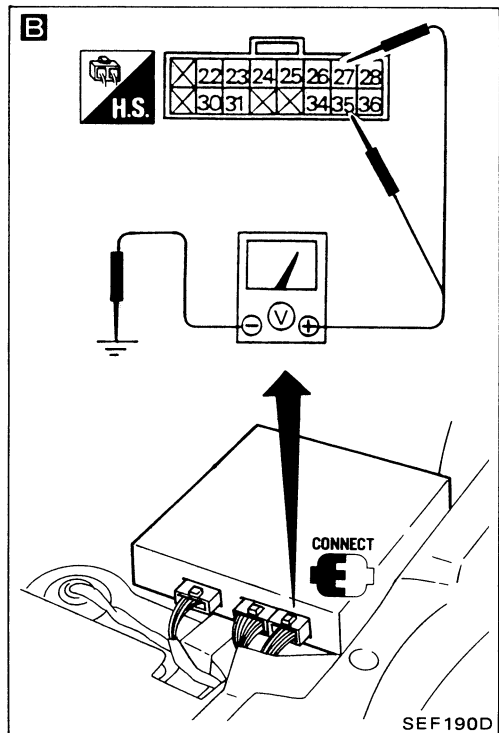
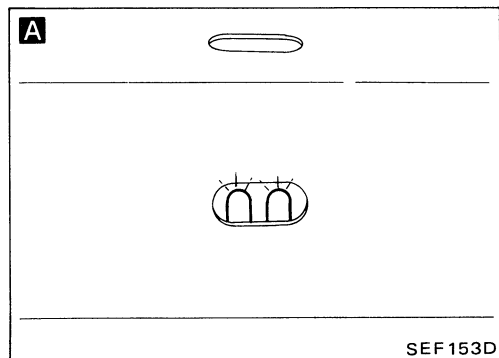

MAIN RELAY (Not self-diagnostic item)

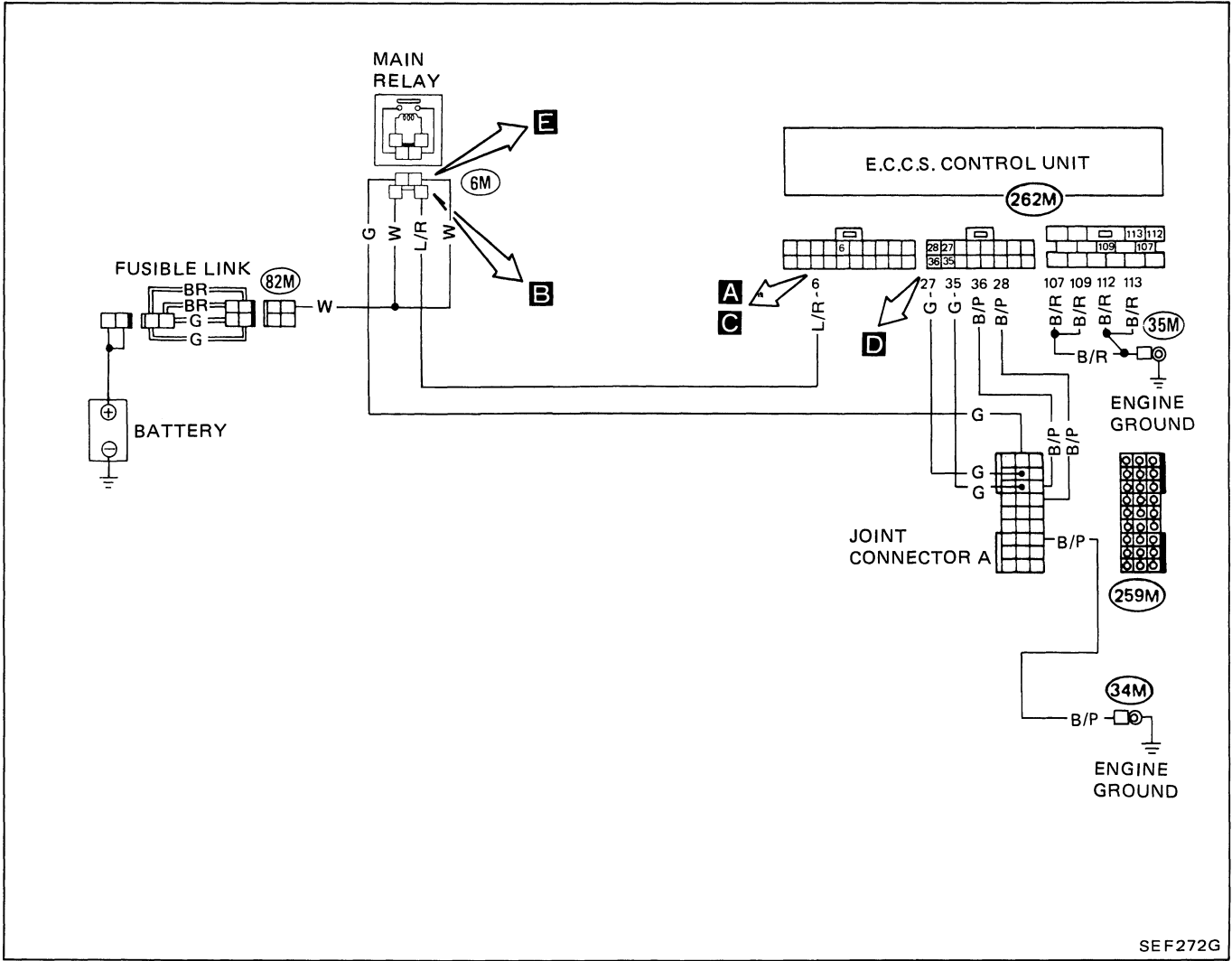

SEF272G

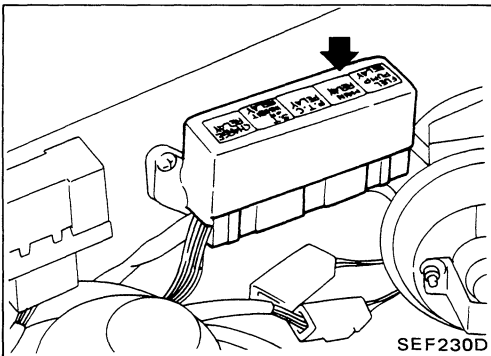

Main relay location

MAIN RELAY (Not self-diagnostic item)

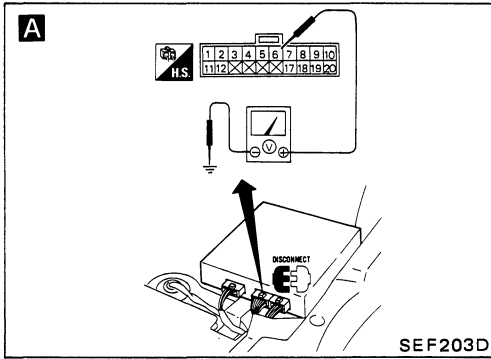

1) Turn ignition switch "OFF".
 2) Disconnect 20-pin connector from E.C.U.
 3) Turn ignition switch "ON" again.
A 4) Check voltage between terminal ⑥ and ground.
Battery voltage should exist.

N.G. →

1) Turn ignition switch "OFF".
 2) Remove main relay.
B 3) Connect terminals ① and ② using a suitable jumper wire.
 4) Turn ignition switch "ON".
A 5) Recheck voltage between terminal ⑥ and ground.
Battery voltage should exist.

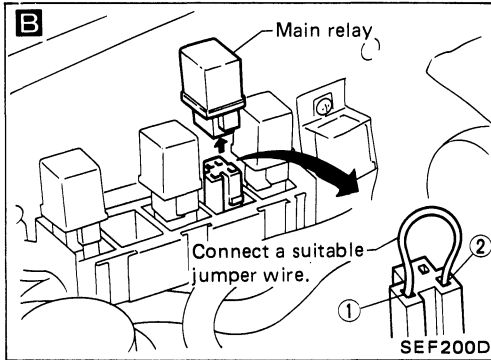

O.K. ↓

1) Turn ignition switch "OFF".
C 2) Connect terminal ⑥ to ground using a suitable jumper wire.
 3) Turn ignition switch "ON".
D 4) Check voltage between terminals ⑳, ⑳ and ground.
Battery voltage should exist.

O.K. ↓

Replace main relay.

N.G. ↓

Check harness continuity between main relay and battery.

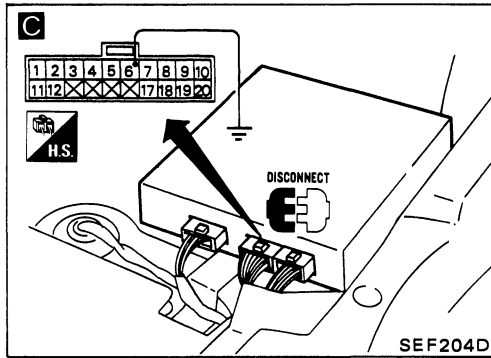

N.G. →

O.K. ↓

1) Turn ignition switch "OFF".
 2) Remove main relay.
E 3) Connect terminals ③ and ④ using a suitable jumper wire.
 4) Turn ignition switch "ON".
D 5) Recheck voltage between terminals ⑳, ⑳ and ground.
Battery voltage should exist.

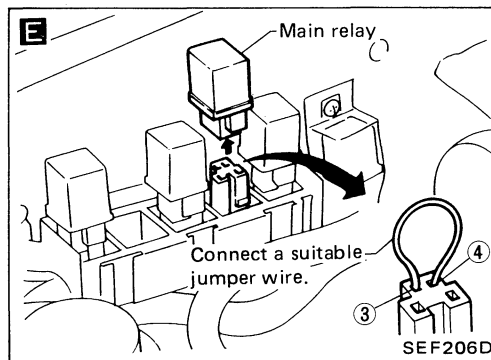
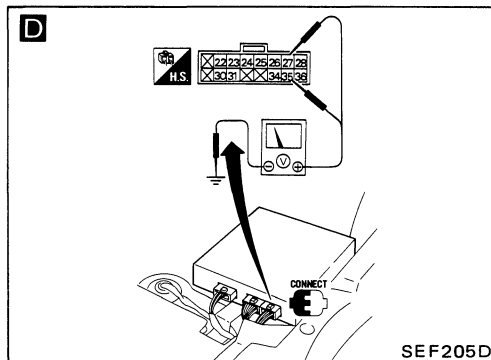

A.I.V. CONTROL (Not self-diagnostic item)

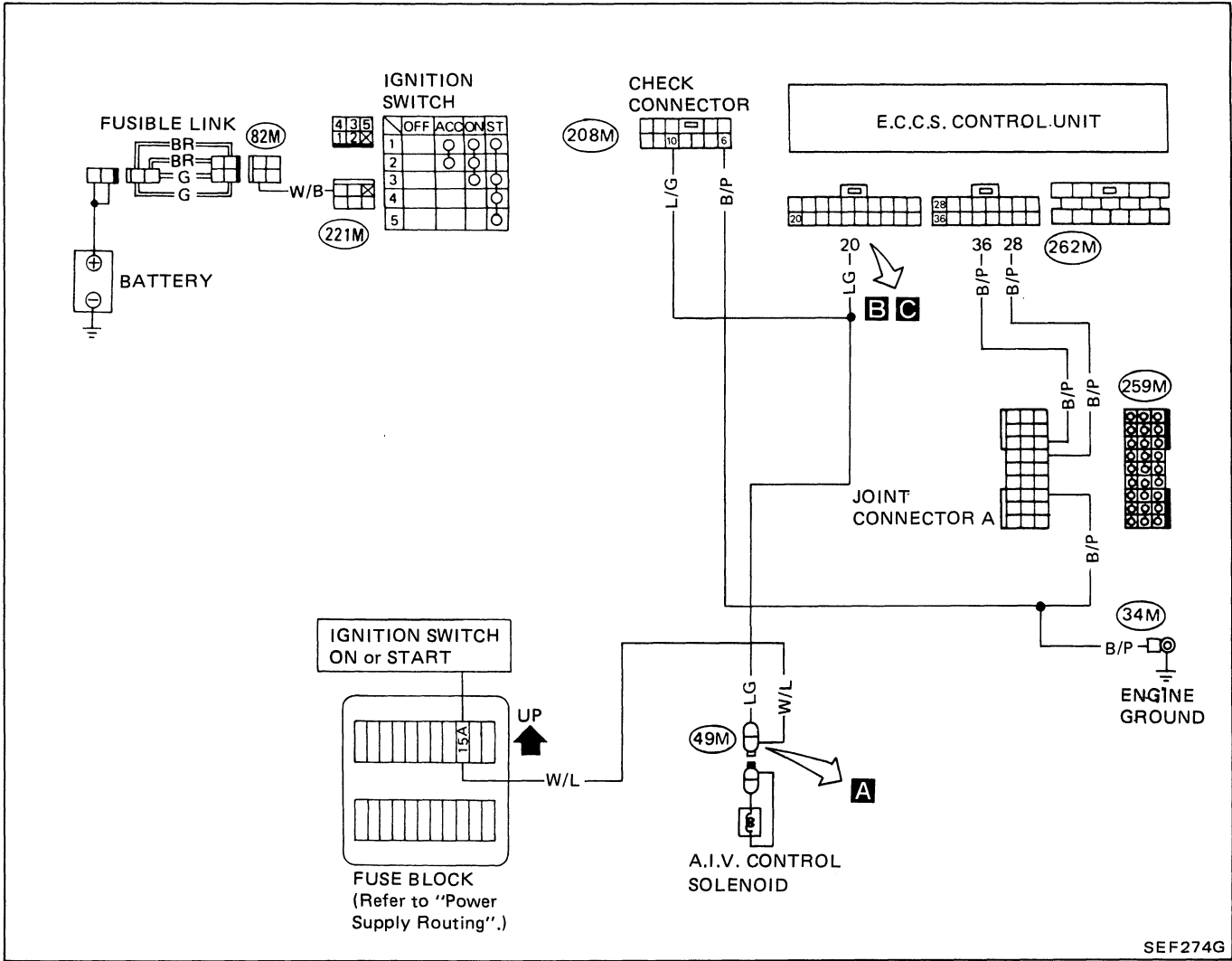

SEF274G

A.I.V. CONTROL (Not self-diagnostic item)

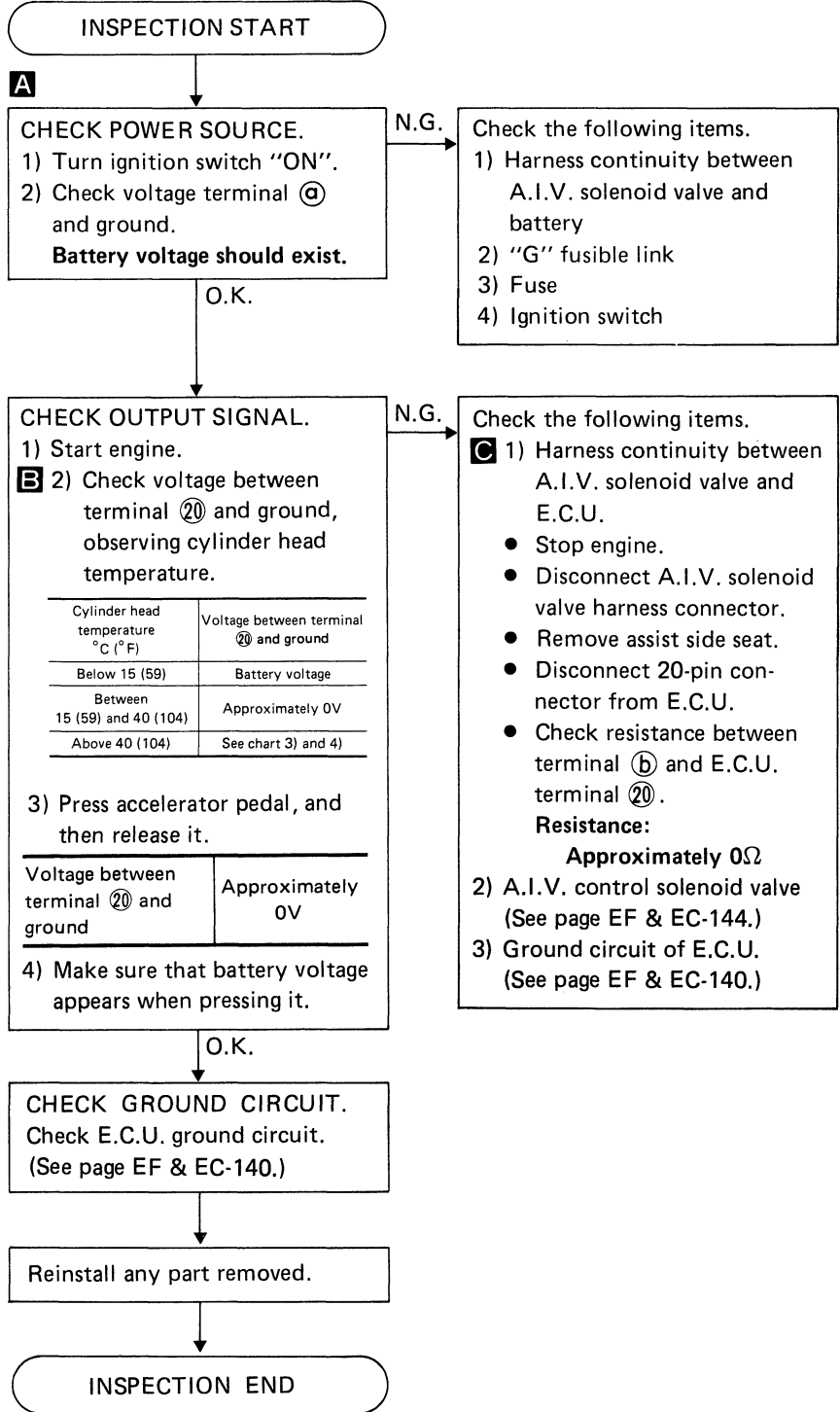
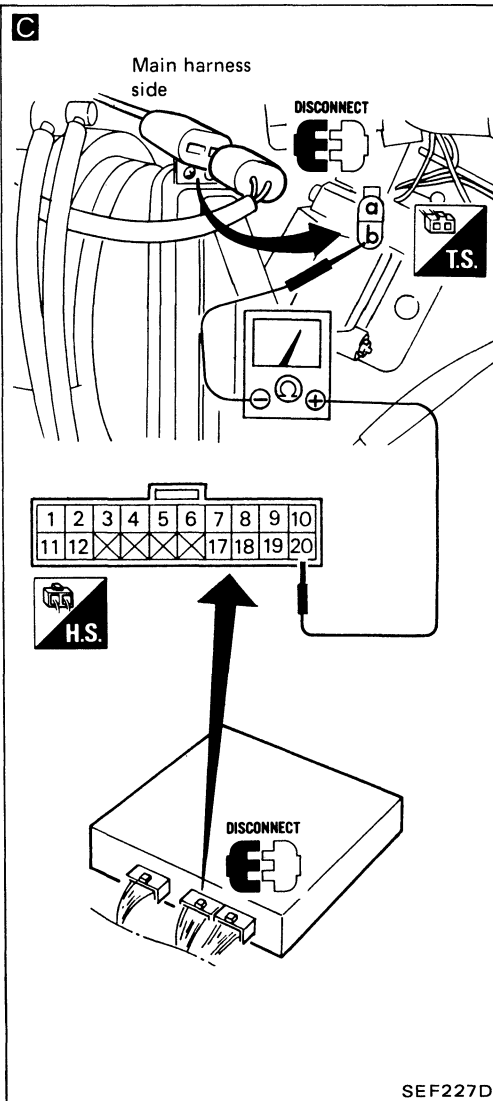
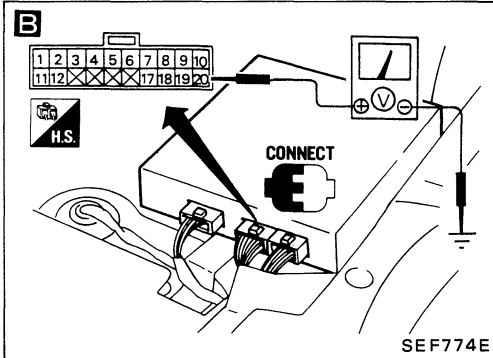
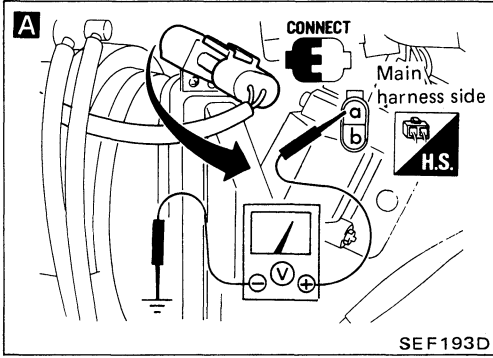

IDLE-UP CONTROL (Not self-diagnostic item)

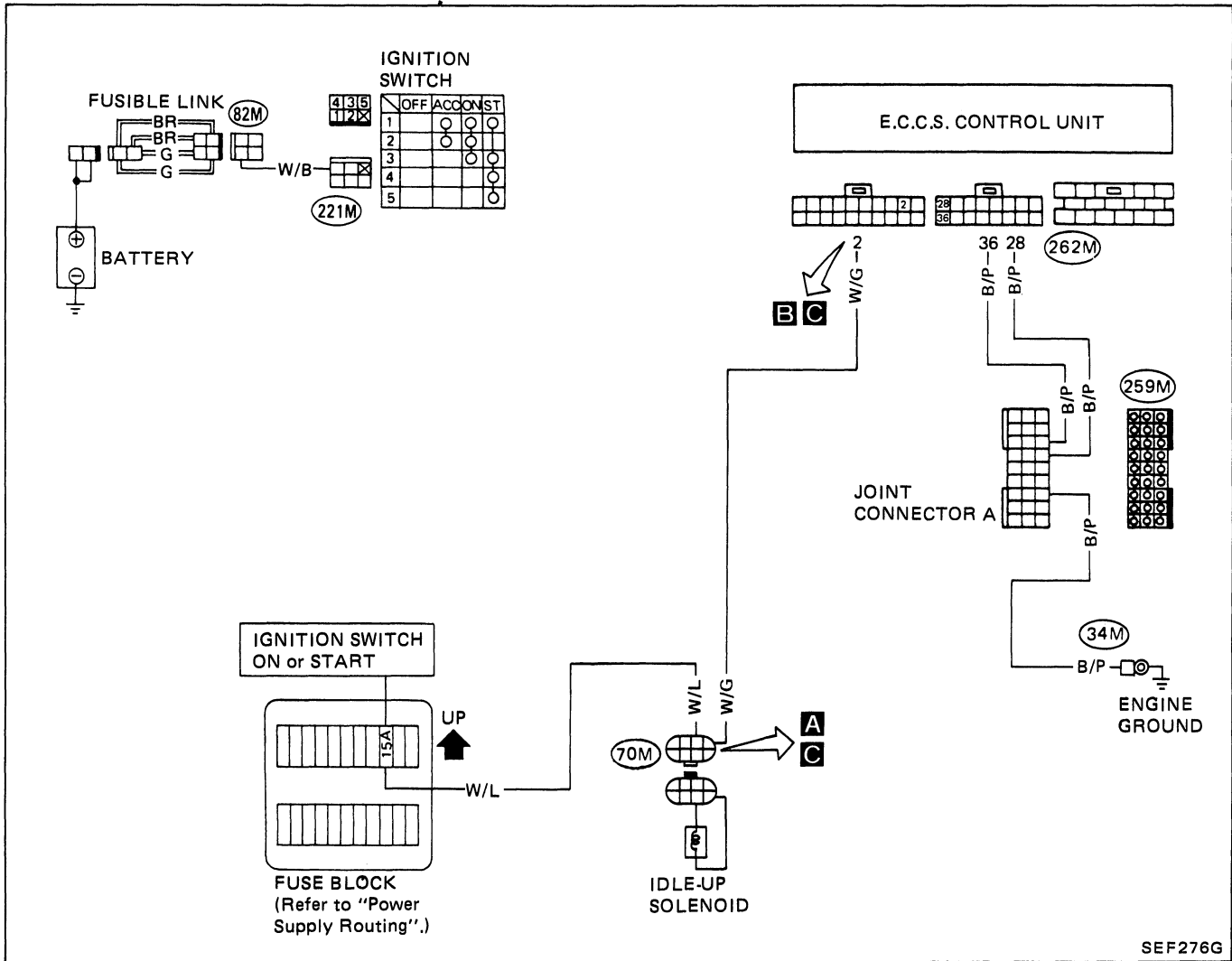

SEF276G

IDLE-UP CONTROL (Not self-diagnostic item)

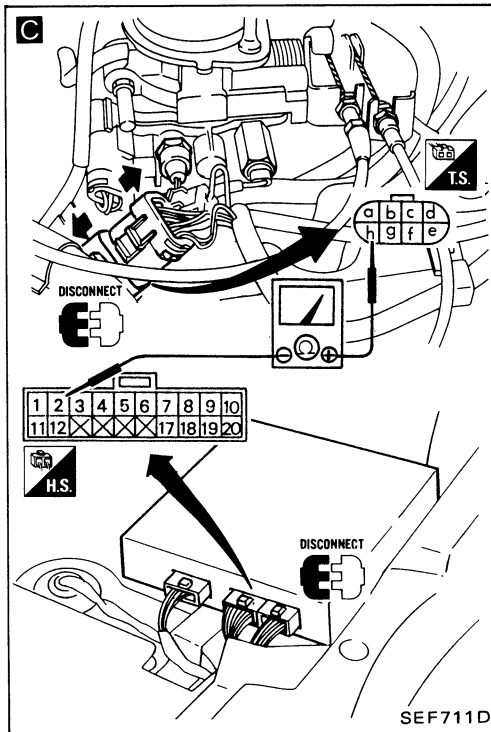
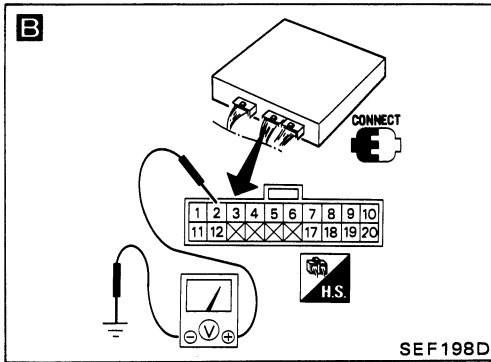
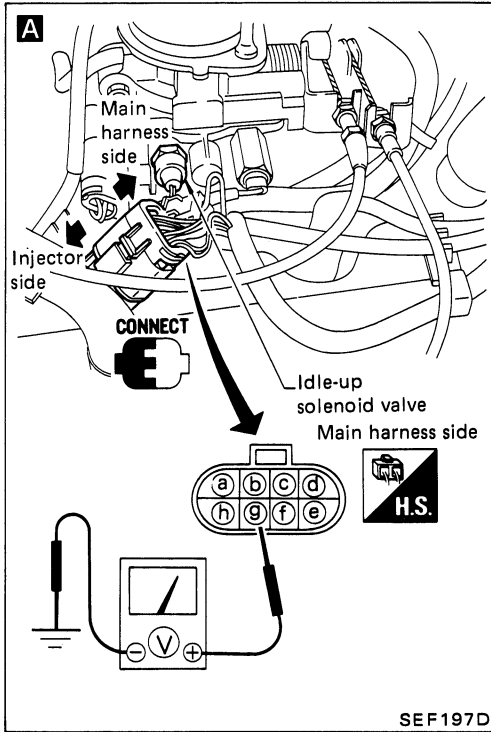

```

    graph TD
        Start([INSPECTION START]) --> A[CHECK POWER SOURCE.]
        A -- N.G. --> A_NG[Check the following items.  
1) Harness continuity between Idle-up solenoid valve and battery  
2) "G" fusible link  
3) Fuse  
4) Ignition switch]
        A -- O.K. --> B[CHECK OUTPUT SIGNAL.]
        B -- N.G. --> B_NG[Check the following items.  
C 1) Harness continuity between Idle-up solenoid valve and E.C.U.  
• Disconnect injector harness connector.  
• Disconnect 20-pin connector from E.C.U.  
• Check resistance between terminal h and E.C.U. terminal 2.  
Resistance:  
Approximately 0Ω  
2) Idle-up solenoid valve. (See page EF & EC-146.)  
3) Ground circuit of E.C.U. (See page EF & EC-140.)]
        B -- O.K. --> Reinstall[Reinstall any part removed.]
        Reinstall --> End([INSPECTION END])
    
```

A CHECK POWER SOURCE.

- 1) Turn ignition switch "ON".
- 2) Check voltage terminal ② and ground.

Battery voltage should exist.

B CHECK OUTPUT SIGNAL.

- 1) Turn ignition switch "OFF" and remove assist side seat.
- 2) Check voltage between ② and ground under the following conditions.
- 3) Start engine.

For about 20 seconds after engine has started.

Voltage: Approximately 0V

- 4) Warm up engine.
- During warming up

Voltage: Approximately 0V- After warm up

Battery voltage should appear.

- 5) Raise engine revolution. (1,300 rpm or more)

Voltage: Approximately 0V

- 6) Reduce engine revolution. (1,100 rpm or less)

Battery voltage should appear.

- 7) Turn load switches "ON".

- Lighting switch
- Power steering oil pressure switch
- Rear defogger switch
- Heater or air conditioner switch

Voltage: Approximately 0V

C 1) Harness continuity between Idle-up solenoid valve and E.C.U.

- Disconnect injector harness connector.
- Disconnect 20-pin connector from E.C.U.
- Check resistance between terminal h and E.C.U. terminal ②.

Resistance: Approximately 0Ω

- 2) Idle-up solenoid valve. (See page EF & EC-146.)
- 3) Ground circuit of E.C.U. (See page EF & EC-140.)

Reinstall any part removed.

CRANK ANGLE SENSOR (Code No. 11)

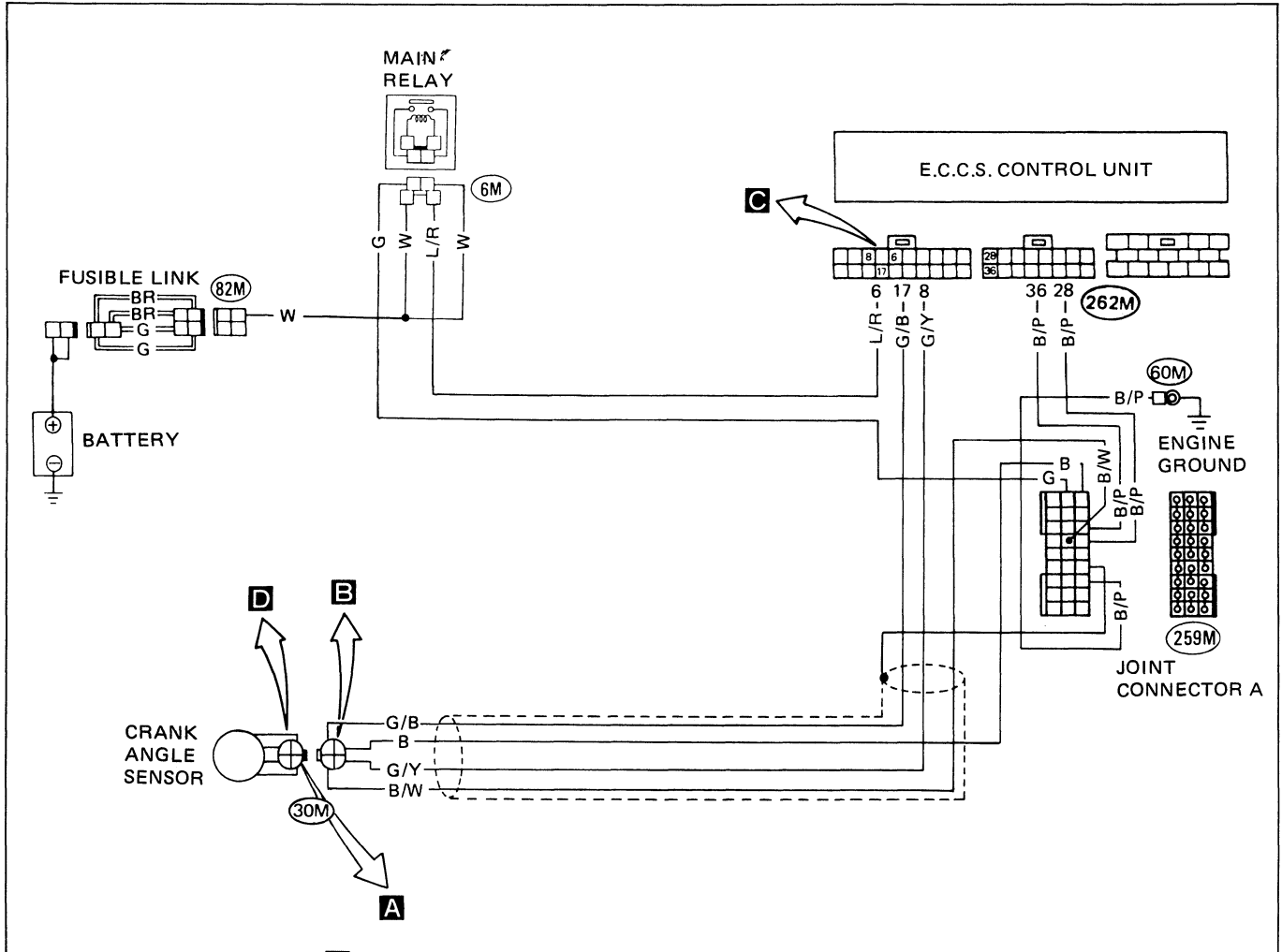

There is no checking point (E) in this wiring diagram.

SEF382H

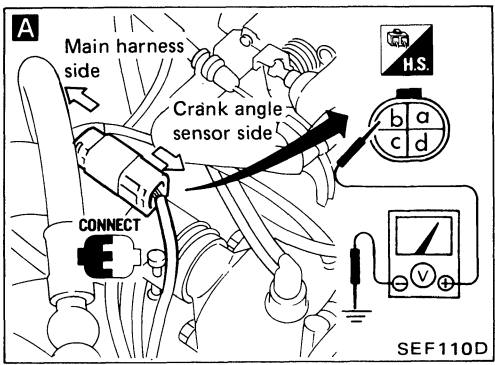

INSPECTION START

A
CHECK POWER SOURCE.
 1) Turn ignition switch "ON".
 2) Check voltage between terminal (b) and ground.
Battery voltage should exist.

- Check the following items.
- 1) Harness continuity between crank angle sensor and battery.
 - 2) Main relay (See page EF & EC-192.)
 - 3) "BR" and "G" fusible links
 - 4) Power source for E.C.U. (See page EF & EC-190.)
 - 5) Ignition switch
 - 6) Joint connector A

O.K.

N.G.



CRANK ANGLE SENSOR (Code No. 11)

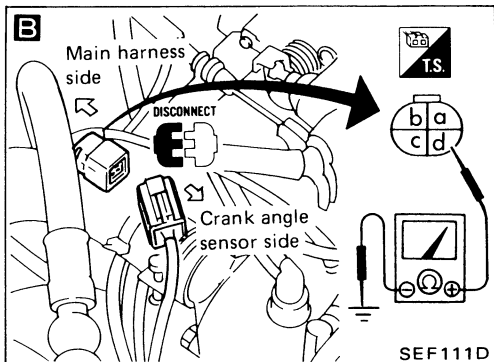

B

CHECK GROUND CIRCUIT.

- 1) Turn ignition switch "OFF".
- 2) Disconnect crank angle sensor harness connector.
- 3) Check resistance between terminal **d** and ground.

Resistance:
Approximately 0Ω

N.G. →

Check the following items.

- 1) Harness continuity between crank angle sensor and ground.
- 2) Joint connector A
- 3) E.C.U. ground circuit (See page EF & EC-190.)

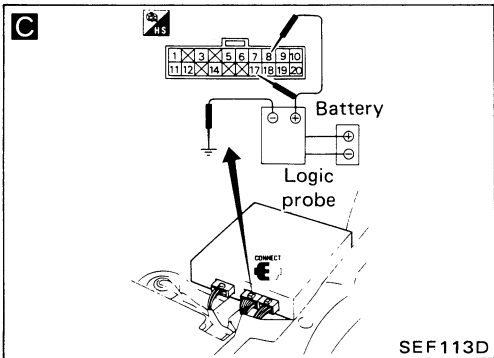

C

CHECK E.C.U. INPUT SIGNALS.

- 1) Remove assist side seat.
- 2) Reconnect crank angle sensor harness connector.
- 3) Start engine.
- 4) Check that pulse signals exist in E.C.U. terminals **8** and **17** with logic probe.

Pulse signals should exist.
8 : 1° signal
17 : 180° signals

N.G. →

Stop engine and check harness continuity between crank angle sensor and E.C.U.

D

- Disconnect crank angle sensor harness connector.
- Disconnect 20-pin connector from E.C.U.

1° signal circuit
Continuity between **c** and **8**
 180° signal circuit
Continuity between **a** and **17**

Resistance:
Approximately 0Ω

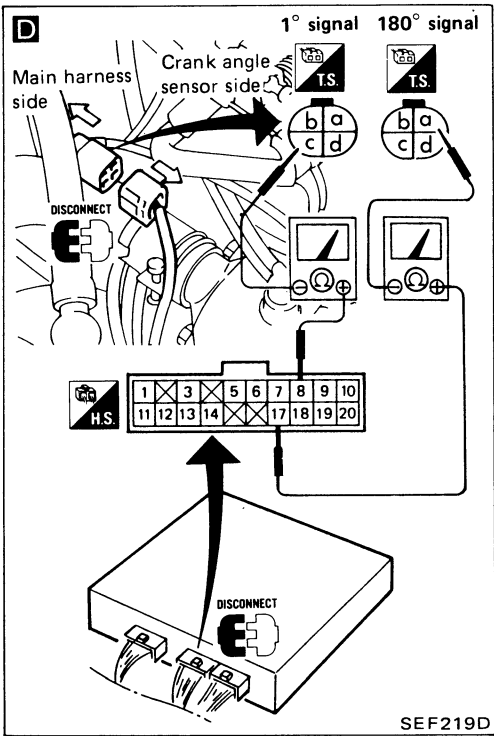

O.K. →

Stop engine and check interference between crank angle sensor harness and high-tension cable.

N.G. →

Separate them.

E

Visually check rotor plate for damage or dust.

O.K. →

Reinstall any part removed.

N.G. →

Clean or replace crank angle sensor.

Erase the self-diagnosis memory.

Perform driving test and then perform self-diagnosis (Mode III) again.

N.G. →

- 1) Perform E.C.U. input/output signal inspection test.
- 2) If N.G., recheck the E.C.U. pin terminal damage or the connection of E.C.U. harness connector.

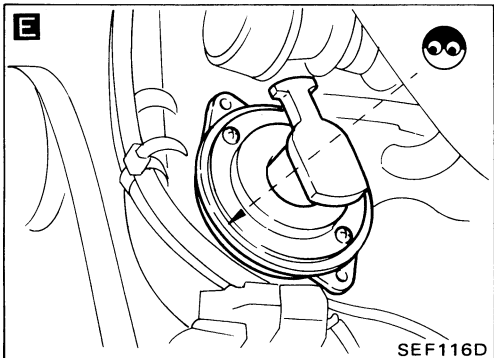

O.K. →

INSPECTION END

AIR FLOW METER (Code No. 12)  (CHECK ENGINE LIGHT ITEM)

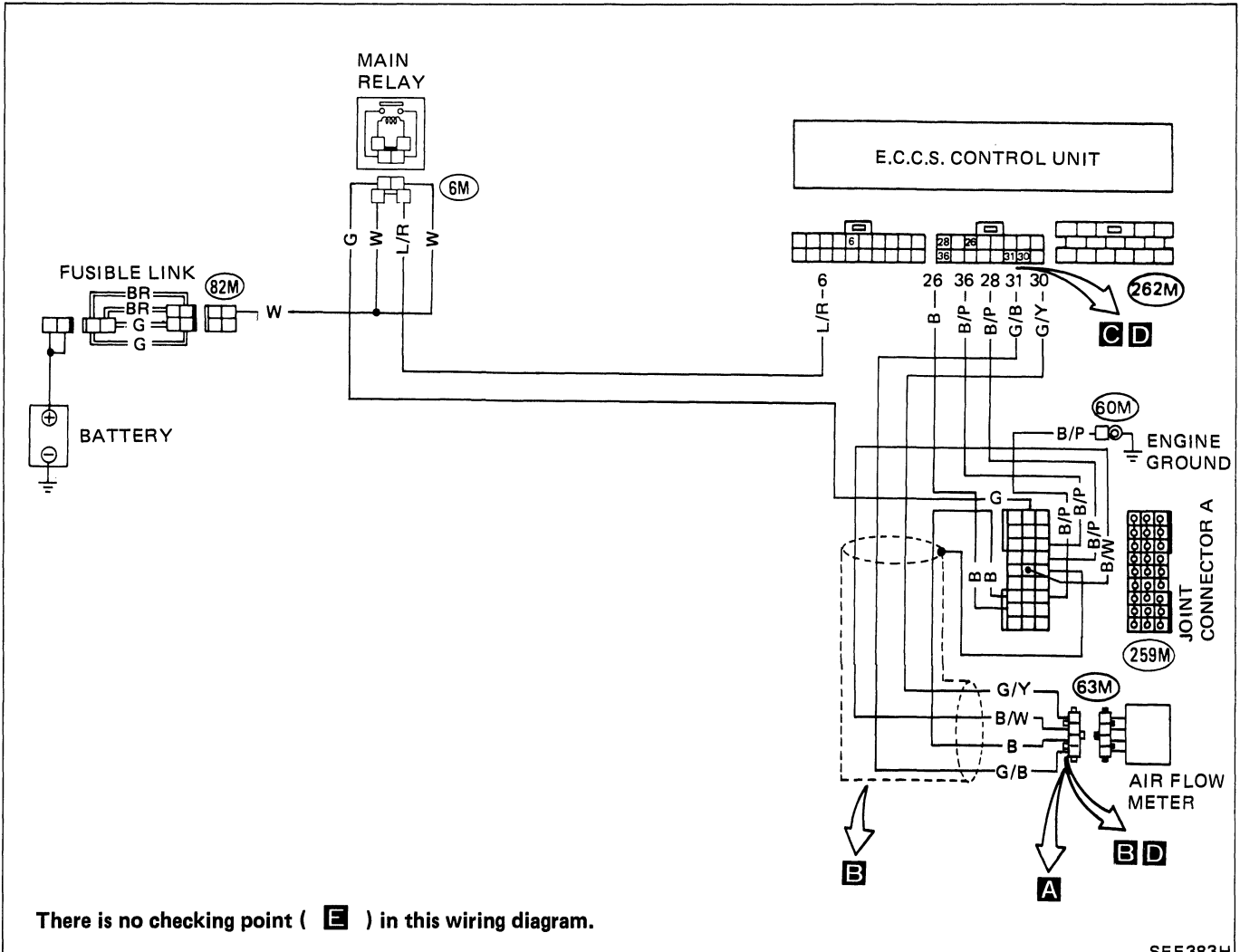

SEF383H

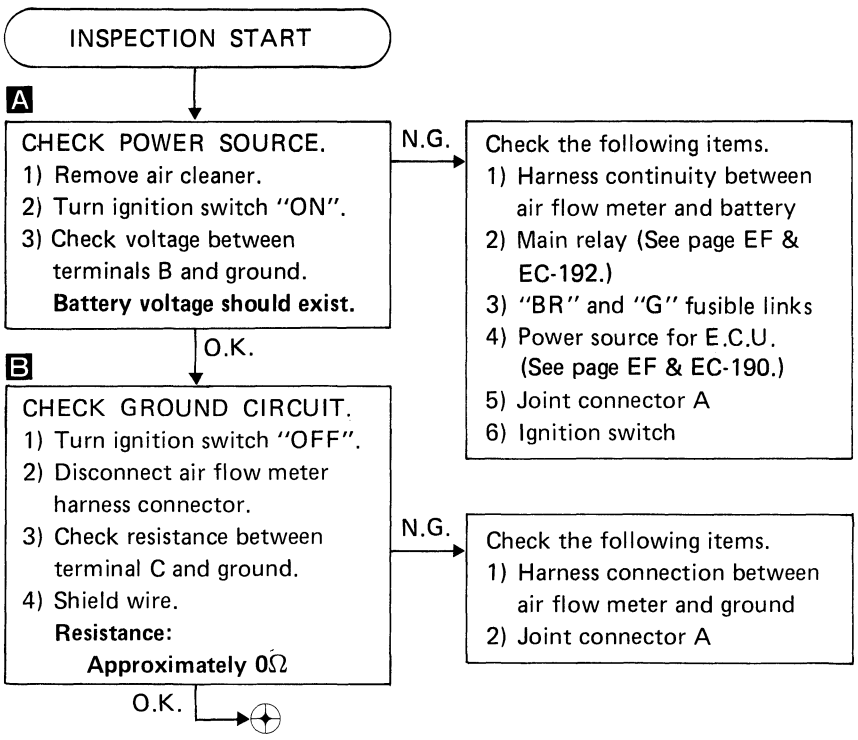
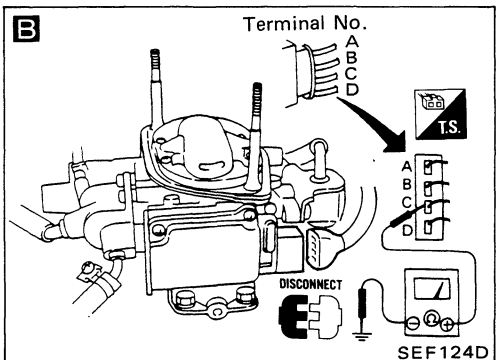
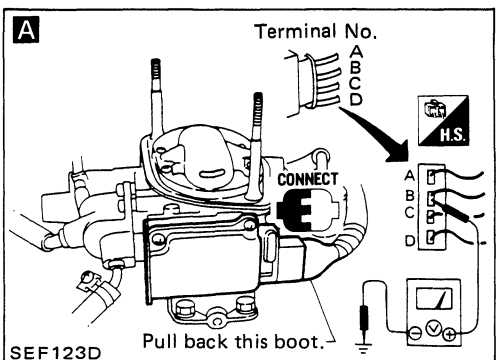

AIR FLOW METER (Code No. 12) CHECK (CHECK ENGINE LIGHT ITEM)

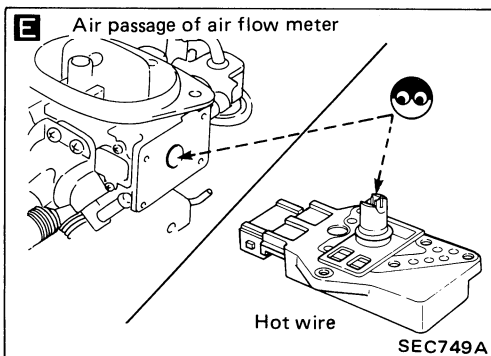
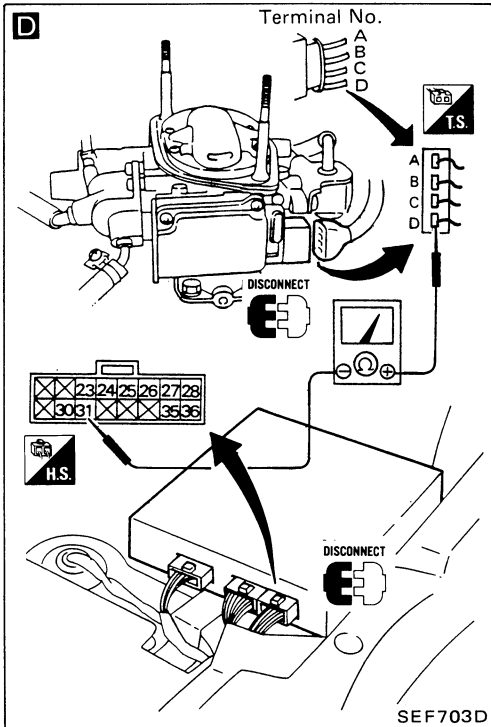
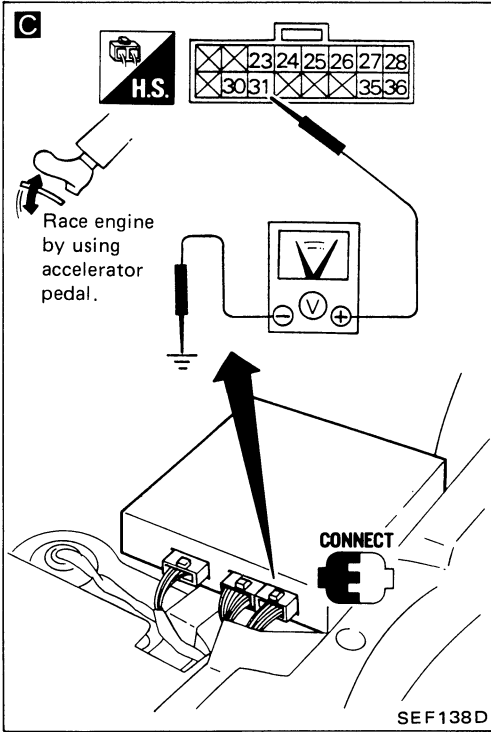

C

CHECK E.C.U. INPUT SIGNAL.

- 1) Remove assist side seat.
- 2) Reconnect air flow meter harness connector.
- 3) Start engine.
- 4) Make sure that voltage between E.C.U. terminal ③① and ground changes by racing engine with accelerator pedal. **Output voltage should change. 0 ~ Approximately 5.0V**

N.G. → **D**

D

Check harness continuity between E.C.U. and air flow meter.

- Stop engine.
- Disconnect air flow meter harness connector.
- Disconnect E.C.U. 16-pin harness connector.
- Check resistance between terminal D and E.C.U. terminal ③①.

Resistance:
Approximately 0Ω
If O.K., replace air flow meter.

O.K. → **E**

E

CHECK AIR PASSAGE OF AIR FLOW METER

- 1) Remove air flow meter from injector body.
- 2) Make sure that air passage of air flow meter in injection body or hot wire is not wet with fuel.

Wet → **D**

Not wet → Reinstall any part removed.

→ Erase the self-diagnosis memory.

→ Perform driving test and then perform self-diagnosis (Mode III) again.

N.G. → **D**

D

- 1) Perform E.C.U. input/output signal inspection test.
- 2) If N.G., recheck the E.C.U. pin terminals damage or the connection of E.C.U. harness connector.

O.K. → **INSPECTION END**

WATER TEMPERATURE SENSOR (Code No. 13)  (CHECK ENGINE LIGHT ITEM)

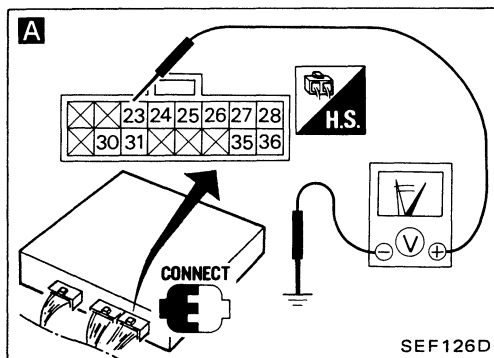
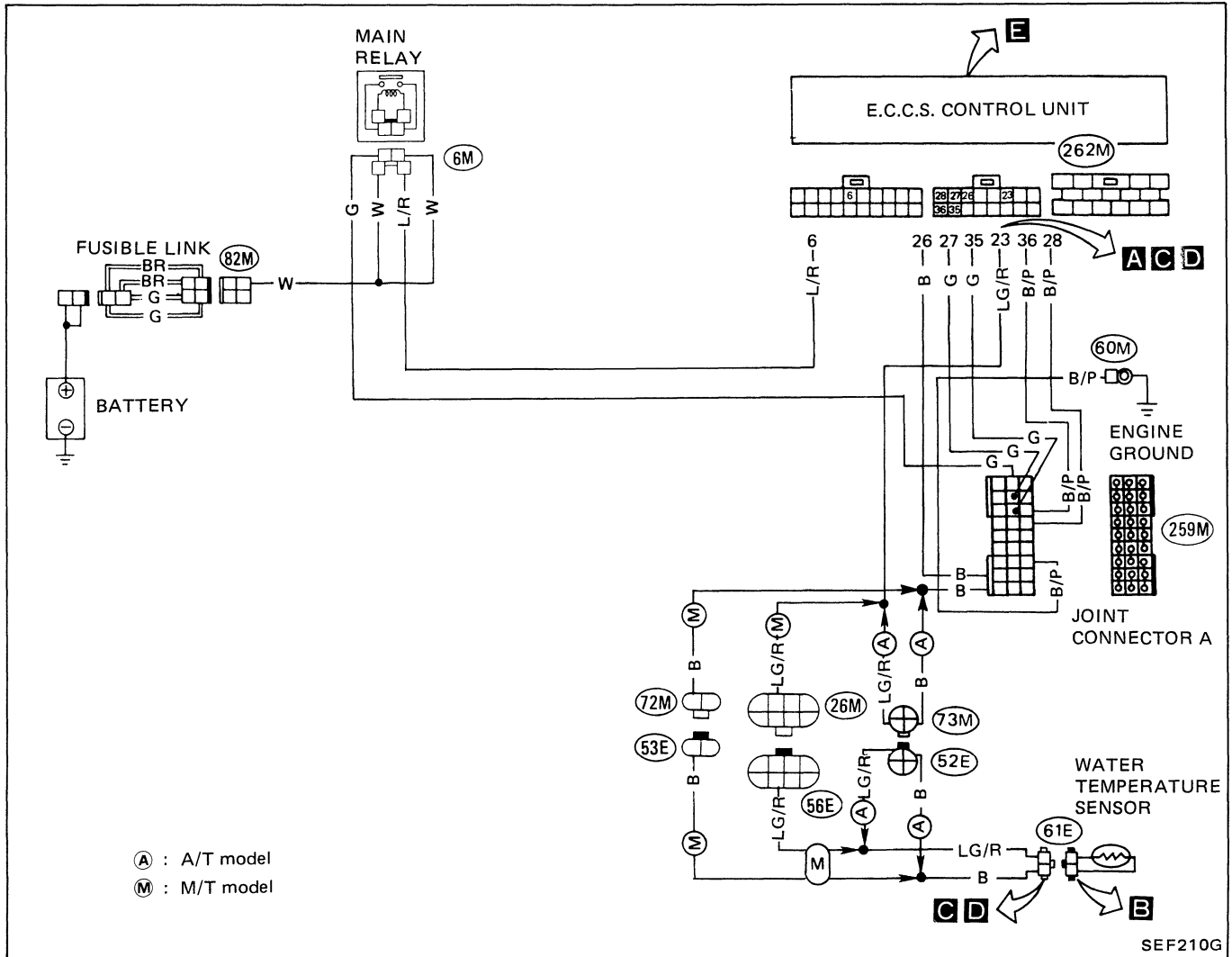

WATER TEMPERATURE SENSOR (Code No. 13)  (CHECK ENGINE LIGHT ITEM)

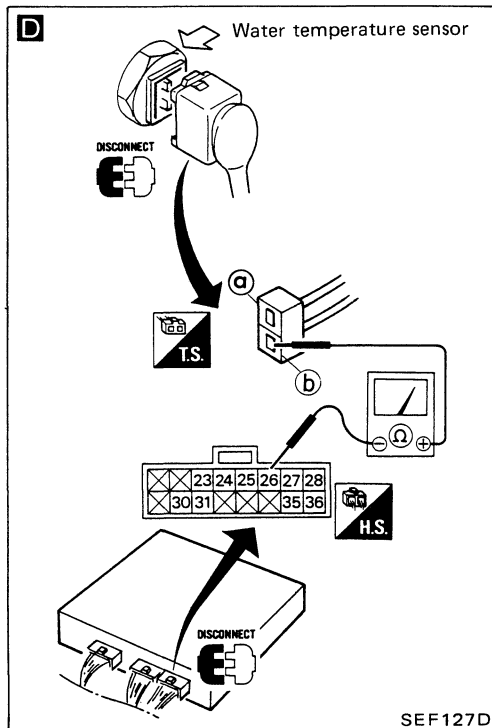
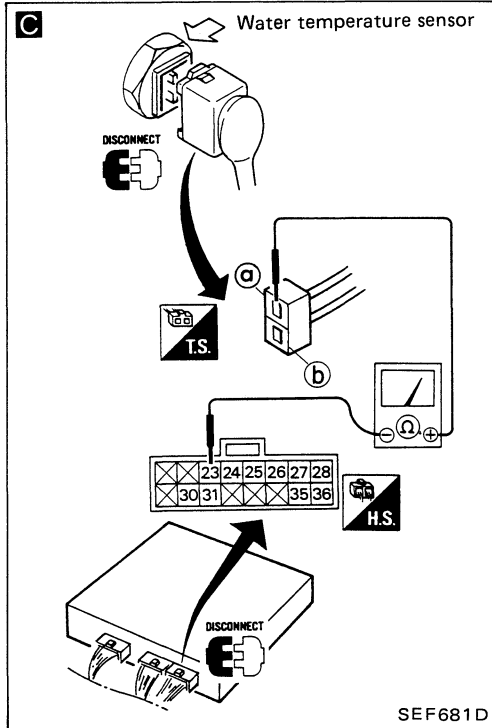
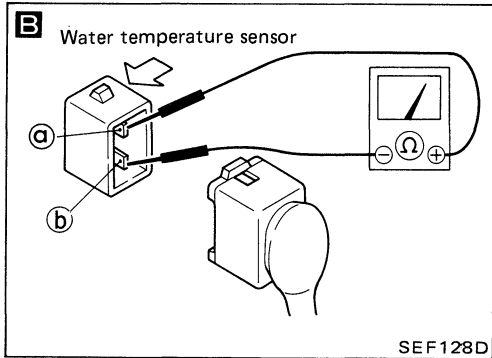

INSPECTION START

A CHECK INPUT SIGNAL.

- 1) Remove assist side seat.
- 2) Start engine.
- 3) Make sure that voltage between E.C.U. terminal ⑳ and ground changes during engine warm up.

Cold → Hot:
Approximately 5 - 0V

N.G.

B 1) Check water temperature sensor resistance.

- Stop engine.
- Disconnect water temperature sensor harness connector.
- Check resistance between terminals ① and ②.

20°C (68°F)	2.3 - 2.7 kΩ
50°C (122°F)	0.77 - 0.87 kΩ
80°C (176°F)	0.30 - 0.33 kΩ

If no continuity, replace water temperature sensor.

2) Check power source for E.C.U. (See page EF & EC-190.)

C 3) Check harness continuity between E.C.U. and water temperature sensor.

- Disconnect 16-pin connector from E.C.U.
- Make sure that water temperature sensor harness connector is disconnected.
- Check resistance between terminal ③ and E.C.U. terminal ㉓.

Resistance:
Approximately 0Ω

O.K.

D CHECK GROUND CIRCUIT.

- 1) Stop engine and disconnect 16-pin connector from E.C.U.
- 2) Disconnect water temperature sensor harness connector.
- 3) Check resistance between terminal ④ and E.C.U. terminal ㉖.

Resistance:
Approximately 0Ω

N.G.

Check the following items.

- 1) Harness connection between water temperature sensor and ground
- 2) Joint connector A

O.K.

Reinstall any part removed.

Erase the self-diagnosis memory.

Perform driving test and then perform self-diagnosis (Mode III) again.

N.G.

- 1) Perform E.C.U. input/output signal inspection test.
- 2) If N.G., recheck the E.C.U. pin terminals damage or the connection of E.C.U. harness connector.

O.K.

INSPECTION END

IGNITION SIGNAL (Code No. 21)

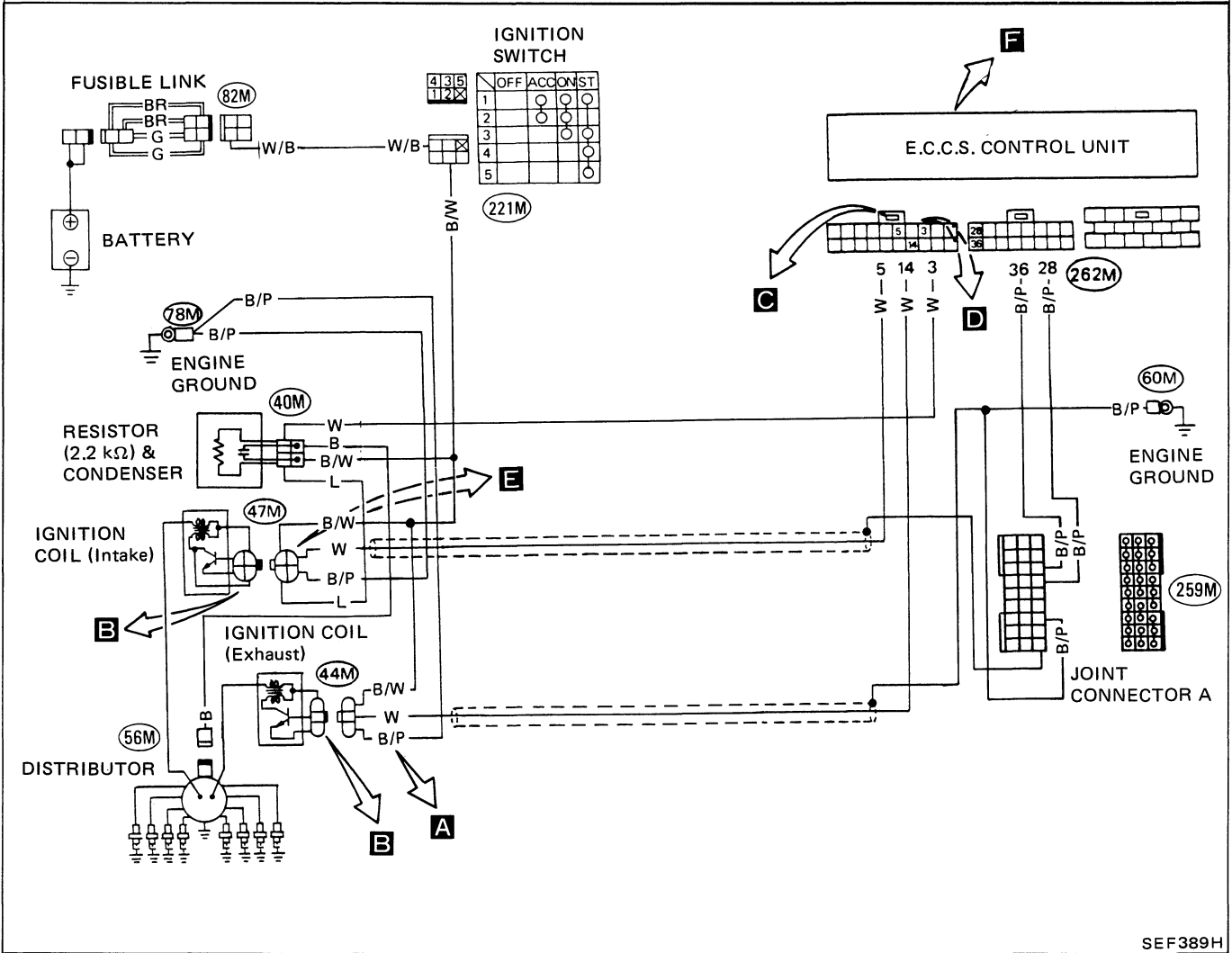

SEF389H

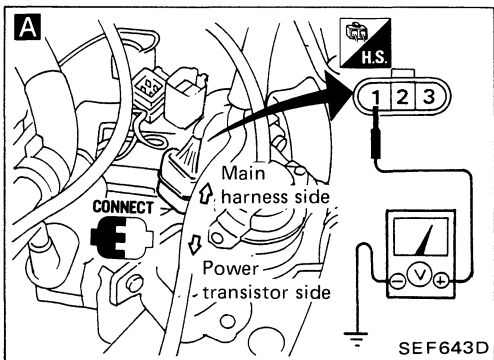
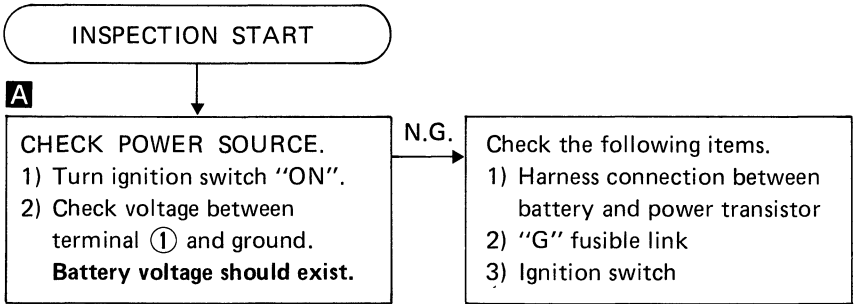

SEF643D

IGNITION SIGNAL (Code No. 21)

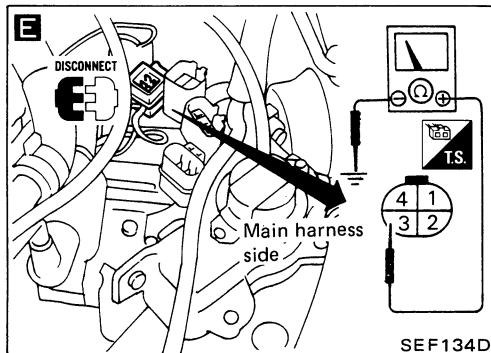
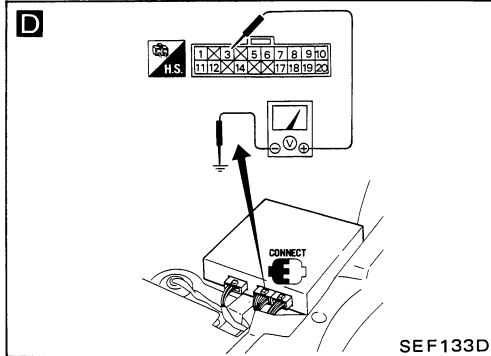
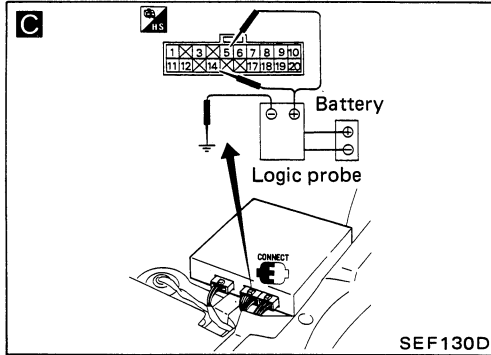
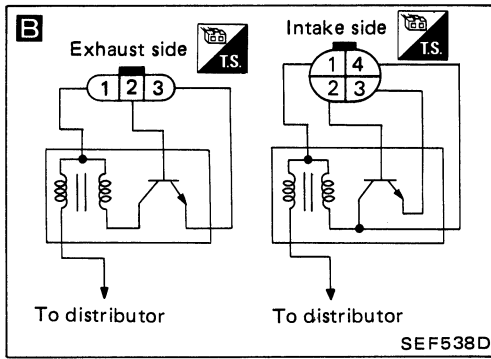

C

CHECK INPUT SIGNAL.

- 1) Turn ignition switch "OFF" and remove assist side seat.
- 2) Start engine.
- 3) Make sure that pulse signals exist between E.C.U. terminals ⑤, ⑭ and ground with logic probe.

Pulse signal should exist.

⑤ : Intake side ignition signal
⑭ : Exhaust side ignition signal

D

CHECK INPUT SIGNAL.

- 1) Stop engine.
- 2) Turn ignition switch "ON".
- 3) Check voltage between E.C.U. terminal ③ and ground.

Battery voltage should exist.

E

CHECK GROUND CIRCUIT.

- 1) Turn ignition switch "OFF".
- 2) Disconnect power transistor harness connector.
- 3) Check resistance between terminal ③ and ground.

Resistance:
Approximately 0Ω

Reinstall any part removed.

Erase the self-diagnosis memory.

Perform driving test and then perform self-diagnosis (Mode III) again.

INSPECTION END

N.G.

- 1) Stop engine and check harness continuity between E.C.U. and power transistor.

B

- 2) Check power transistor with circuit tester.
 - Disconnect harness connector for ignition coil and power transistor.
 - Do not disconnect T-type harness connector for ignition coil.**

① : To ignition coil (+) side
② : To E.C.U.
③ : To engine ground
④ : To ignition coil (-) side

Terminal No.	Tester polarity	Continuity
① or ④	+	No continuity
③	-	
① or ④	-	Continuity should exist.
③	+	
① or ④	+	No continuity
②	-	
① or ④	-	Continuity should exist.
②	+	

If N.G., replace power transistor.

As for the exhaust side, check primary circuit of ignition coil before replacing power transistor.

- 3) Check "G" fusible link.
- 4) Check continuity of ignition coil.
- 5) Check ignition switch.
- 6) Joint connector.

Check harness continuity between E.C.U. and battery.

Check the following items.

- 1) Harness connection between power transistor and engine ground
- 2) Engine ground

N.G.

- 1) Perform E.C.U. input/output signal inspection test.
- 2) If N.G., recheck the E.C.U. pin terminals damage or the connection of E.C.U. harness connector.

ENGINE CONTROL UNIT (Code No. 31) (CHECK ENGINE LIGHT ITEM)

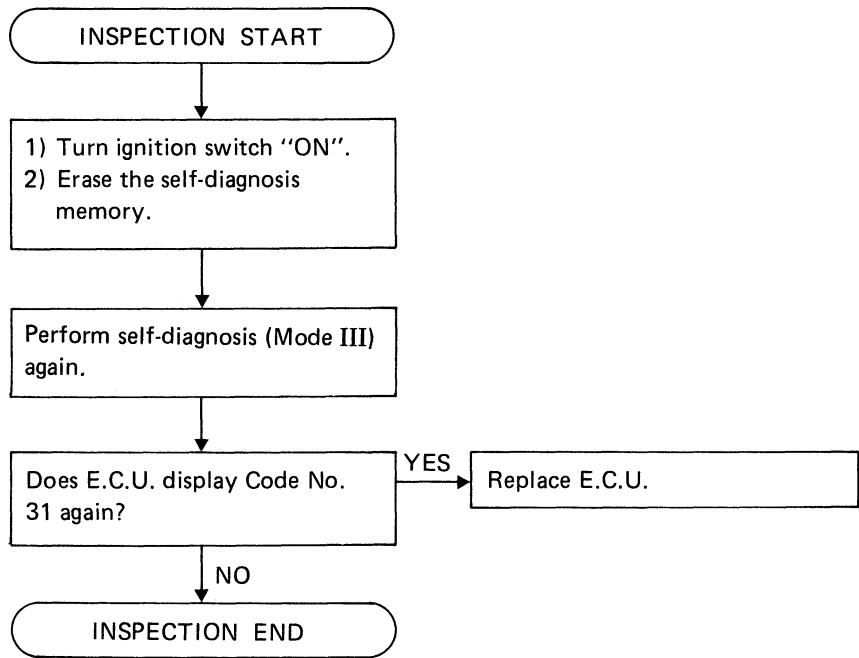

NOTE

E.G.R. FUNCTION (Code No. 32) (CHECK ENGINE LIGHT ITEM): For California (Not self-diagnostic item): Except for California

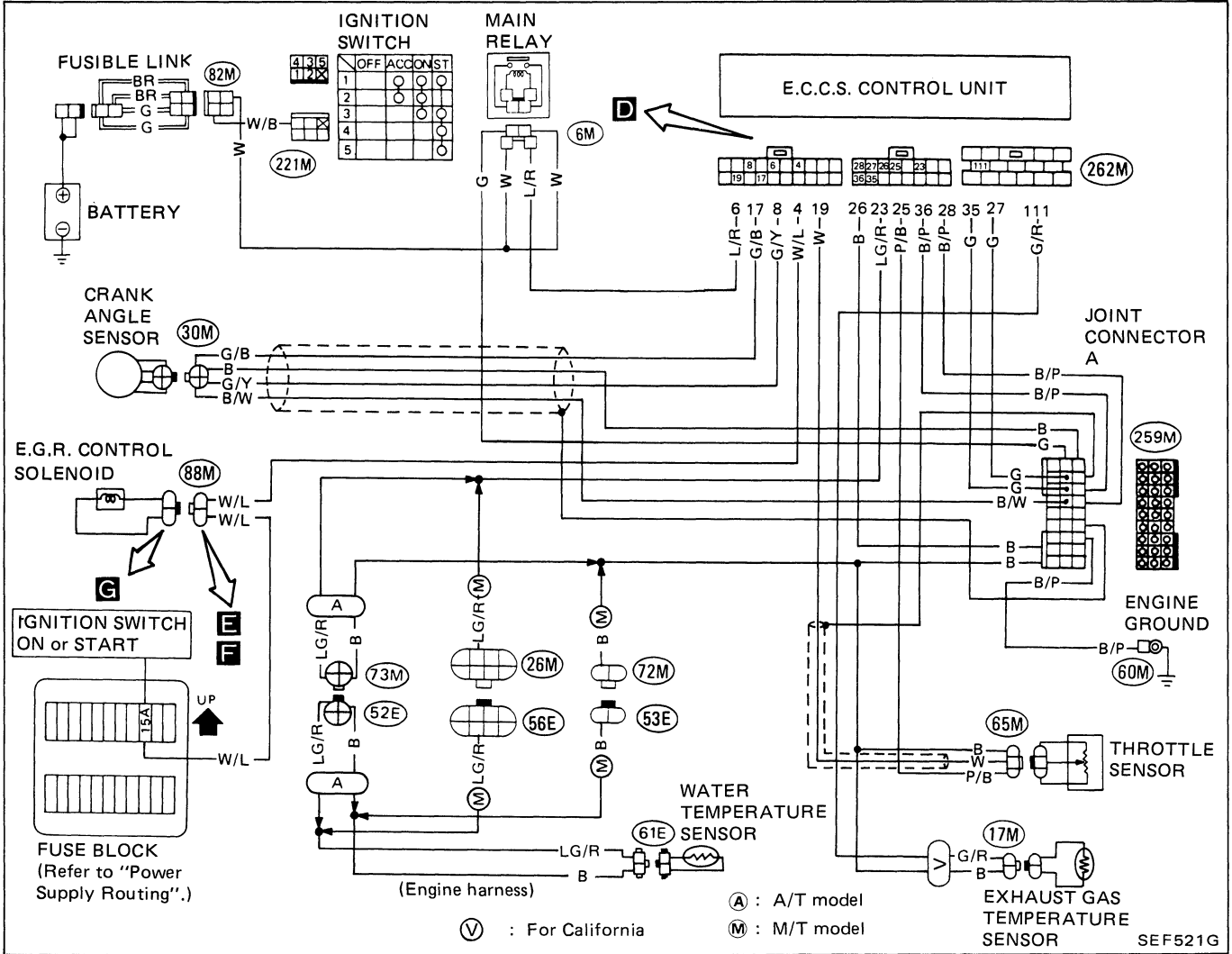

The following is necessary to perform this inspection.

1. Pull out E.C.U. installed under the assist seat.
2. Warm up engine sufficiently.

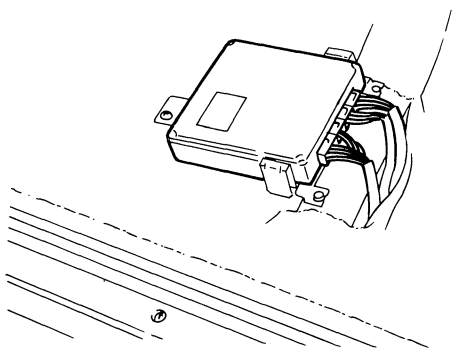

SEF808F

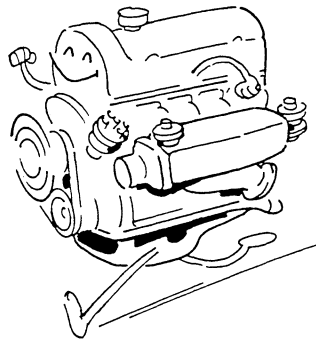

SEF802F

E.G.R. FUNCTION (Code No. 32) (CHECK ENGINE LIGHT ITEM): For California (Not self-diagnostic item): Except for California

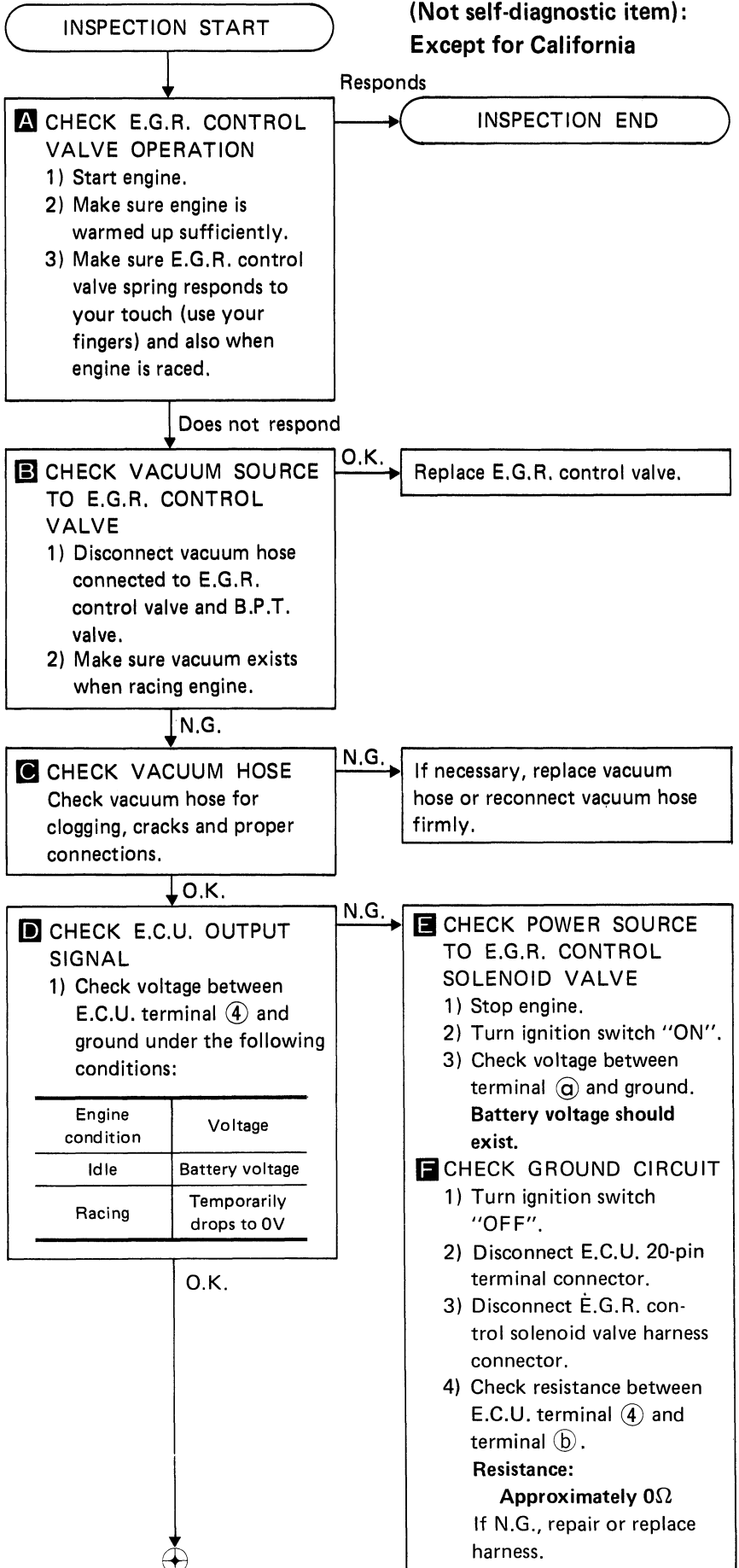
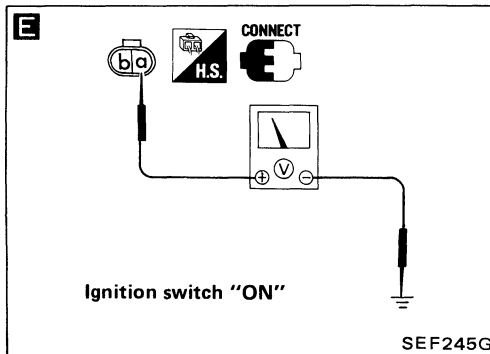
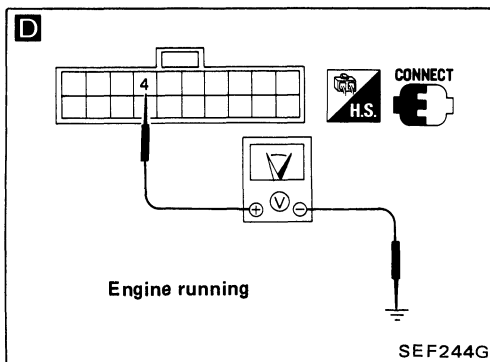
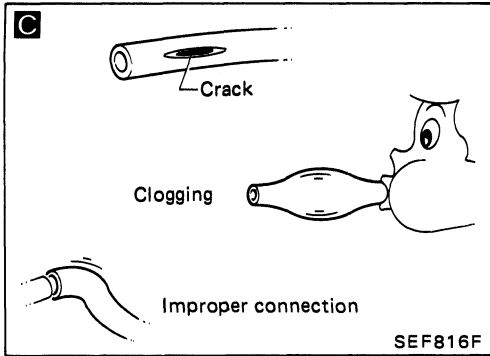
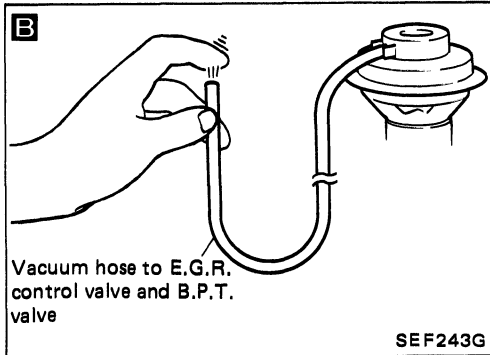
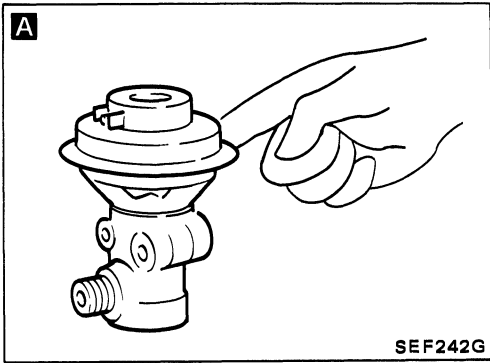

E.G.R. FUNCTION (Code No. 32) ^HCHECK (CHECK ENGINE LIGHT ITEM): For California
 (Not self-diagnostic item):
 Except for California

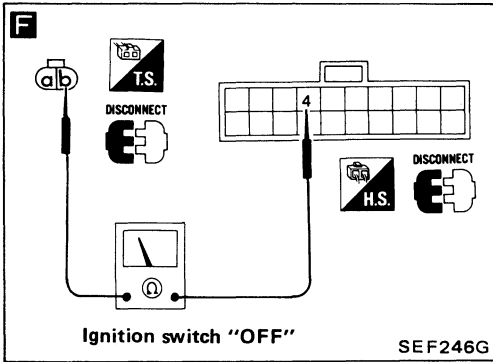

G CHECK E.G.R. CONTROL SOLENOID VALVE

- 1) Stop engine.
- 2) Remove E.G.R. control solenoid valve from vehicle.
- 3) Check the port continuity.

Solenoid valve	Continuity
When current flows	A - B
When current does not flow	B - C

N.G. → Replace E.G.R. control solenoid valve.

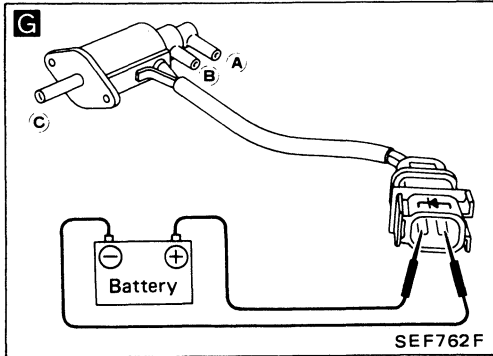

H CHECK E.G.R. CONTROL VALVE

- 1) Remove E.G.R. control valve from vehicle.
- 2) Apply vacuum to E.G.R. vacuum port with a hand vacuum pump.

E.G.R. control valve spring should lift.

N.G. → Valve spring may be stuck. Clean if necessary. If this does not correct trouble, replace E.G.R. control valve.

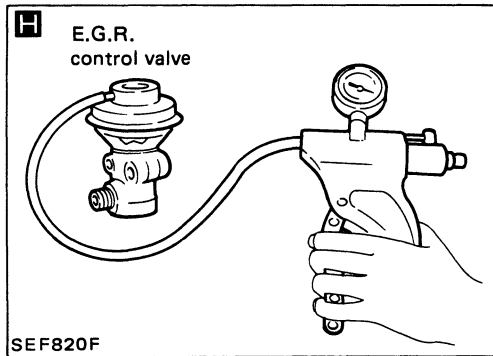

Except for California
 O.K. → **INSPECTION END**

O.K. For California
 Check resistance of exhaust gas temperature sensor.
 (See page EF & EC-164.)

Reinstall any part removed.

Erase the self-diagnosis memory.
 Make sure Code No. 55 is displayed in Mode III.

ELECTRONIC CONTROL SYSTEM INSPECTION

E.G.R. FUNCTION (Code No. 32)



(CHECK ENGINE LIGHT ITEM): For California
(Not self-diagnosis item): Except for California

I ROAD TEST

Test condition

Drive vehicle under the following conditions using a suitable shift position.

- ① Engine speed:
2,300±500 rpm
- ② Intake manifold vacuum:
-36.0±6.7 kPa
(-270±50 mmHg, -10.63±1.97 inHg)

Driving mode

- (A) : Test condition
- (B) : 16 seconds or more

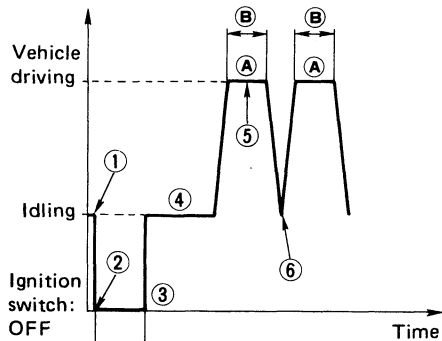

Until green and red LEDs go off.

- ① Start engine and warm it up sufficiently.
- ② Turn off ignition switch and keep it off until green and red LEDs go off.
- ③ Start engine and make sure that air conditioner switch and rear defogger are turned "OFF" during driving test.
- ④ Keep engine running for at least 1 minute.
- ⑤ Shift to suitable gear position and drive in "Test condition" for at least 16 seconds.
- ⑥ Decrease engine revolutions to less than 1,500 rpm.
- ⑦ Repeat steps ⑤ through ⑥ at least 1 time.

SEF302H

I Perform driving test under the following conditions:
 1) Warm up engine sufficiently.
 2) Use test driving modes indicated in figure **I**.

J Make sure check engine light does not come "ON" during driving test.

Comes "ON"

Perform self-diagnosis and find malfunction code. According to displayed code No., perform electronic control system inspection.

Does not come "ON"

INSPECTION END

J

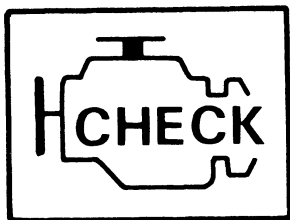

CHECK ENGINE LIGHT

SEF924F

EXHAUST GAS SENSOR (Code No. 33) (CHECK ENGINE LIGHT ITEM)

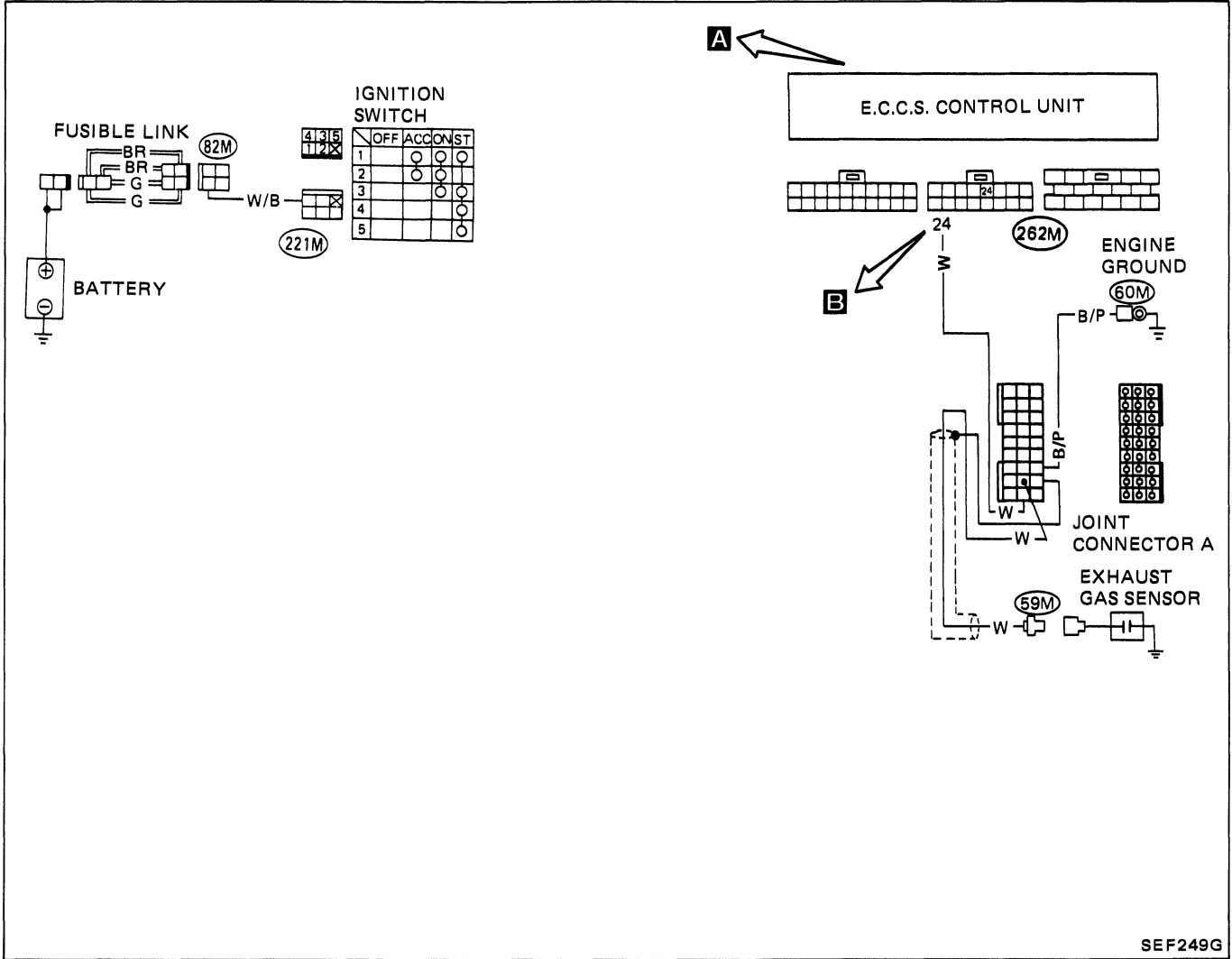

SEF249G

The following is necessary to perform this inspection.

1. Pull out E.C.U. installed under the assist seat.
2. Warm up engine sufficiently.

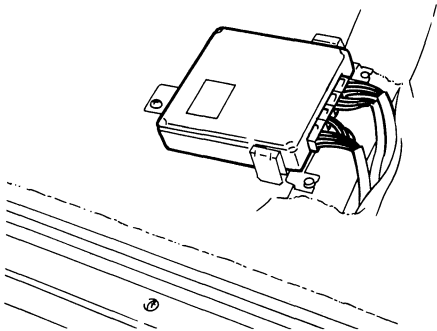

SEF808F

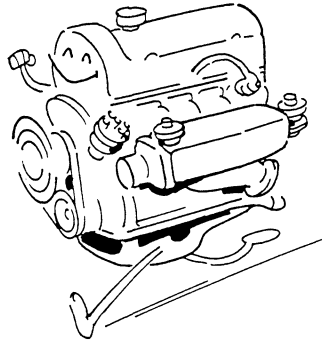

SEF802F

EXHAUST GAS SENSOR (Code No. 33) (CHECK ENGINE LIGHT ITEM)

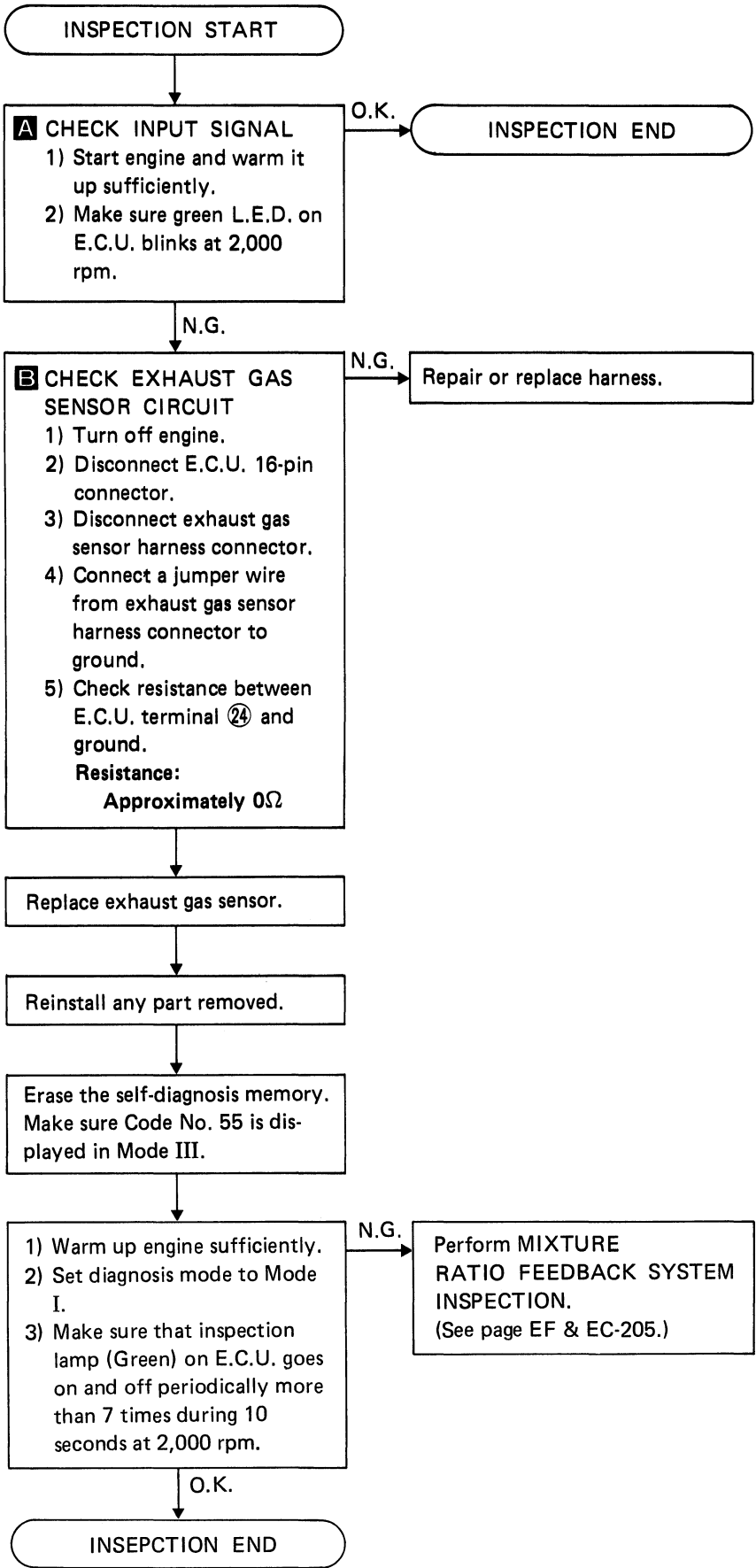
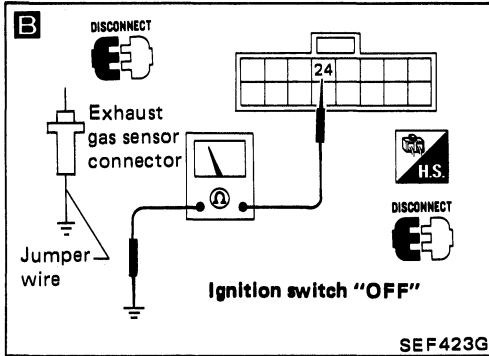
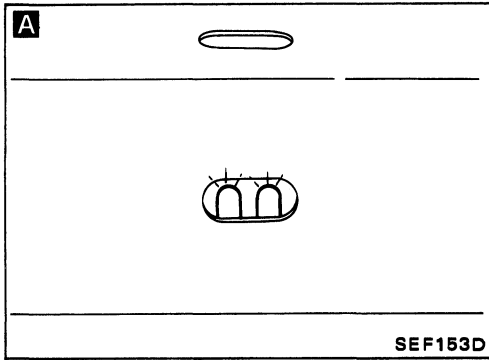

EXHAUST GAS TEMPERATURE SENSOR (Code No. 35) (CHECK ENGINE LIGHT ITEM); CALIFORNIA MODEL ONLY

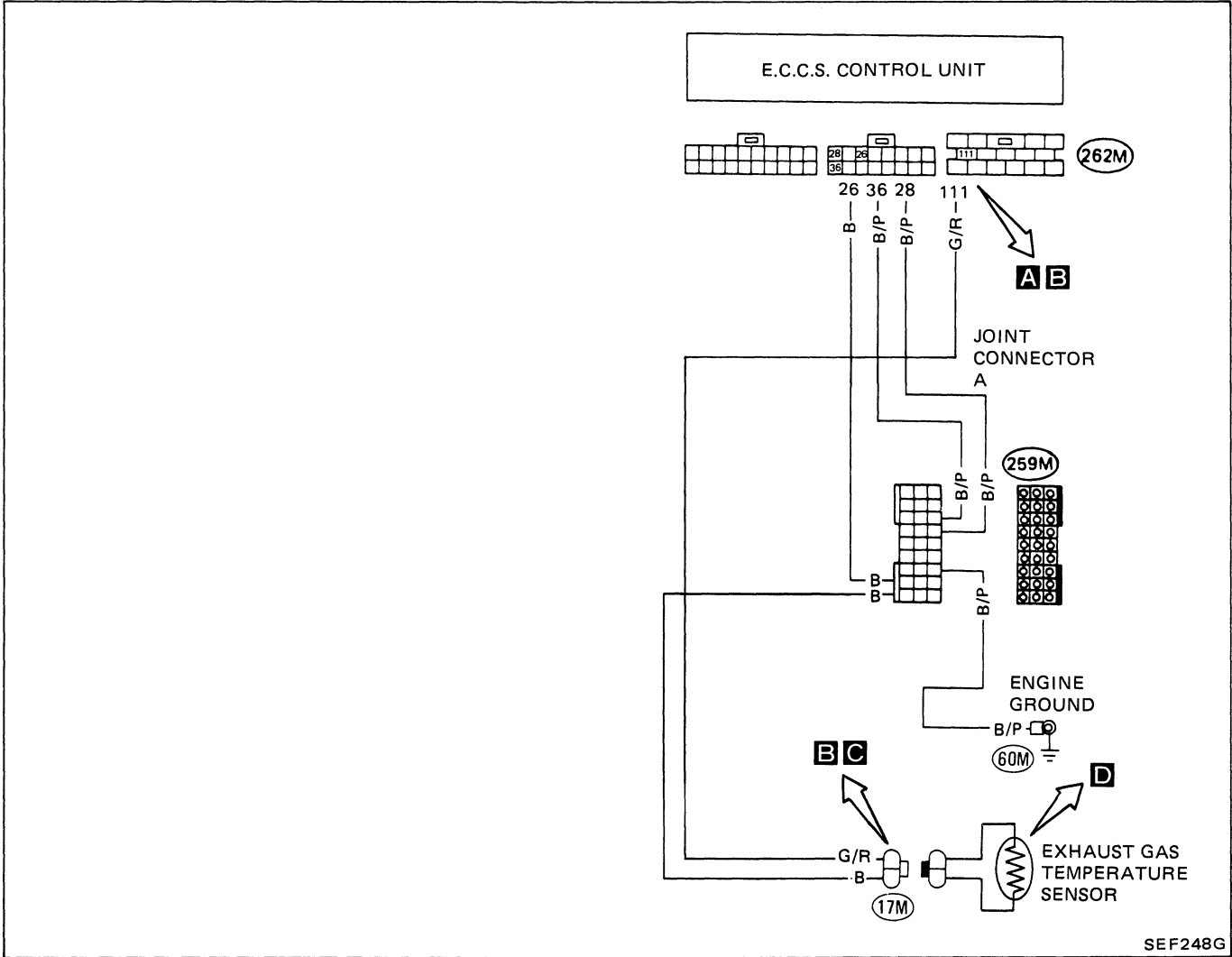

The following is necessary to perform this inspection.

1. Pull out E.C.U. installed under the assist seat.
2.
 - Disconnect vacuum hose connected to E.G.R. control valve.
 - Connect a hand vacuum pump to E.G.R. control valve.
3. Warm up engine sufficiently.

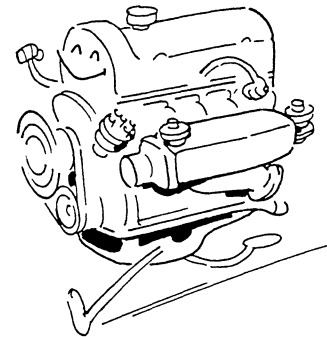
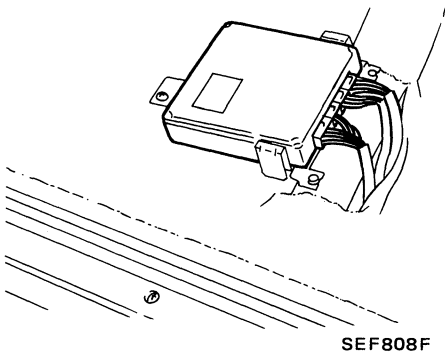

EXHAUST GAS TEMPERATURE SENSOR (Code No. 35) (CHECK ENGINE LIGHT ITEM); CALIFORNIA MODEL ONLY

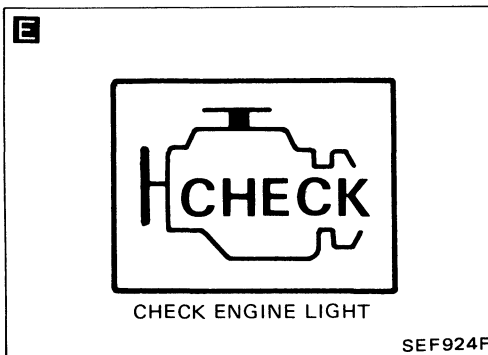
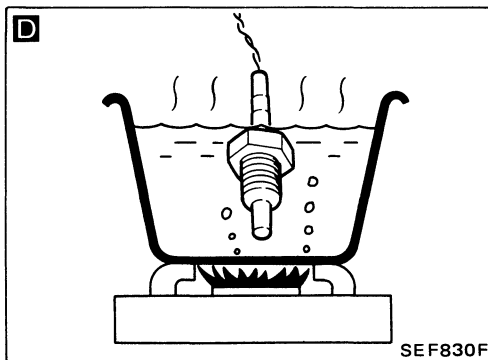
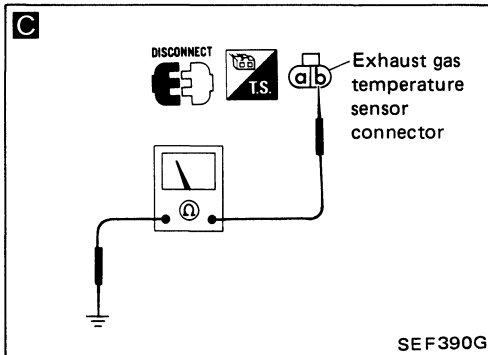
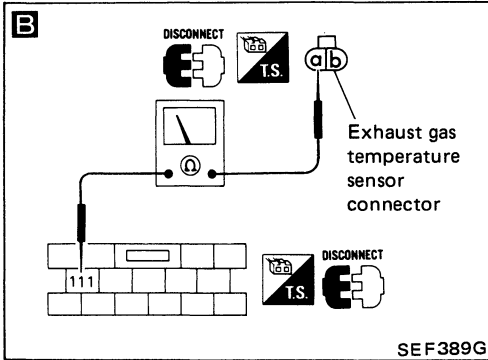
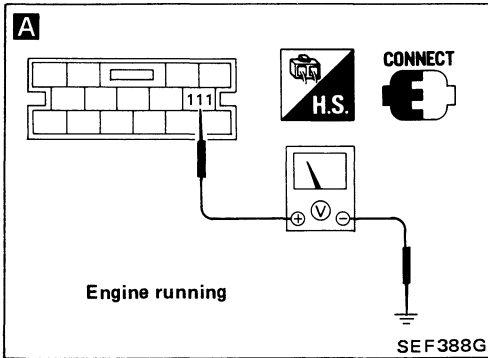

INSPECTION START

A CHECK INPUT SIGNAL

- 1) Start engine and warm it up sufficiently.
- 2) Keep engine speed at approximately 2,000 rpm.
- 3) Check voltage between E.C.U. terminal 111 and ground under the following conditions:

Condition	Voltage
When vacuum is not applied to E.G.R. control valve	1.0V or more
When vacuum is applied to E.G.R. control valve	0 - 1.0V

A sufficient vacuum applied with a hand vacuum pump may cause the engine to stall.

O.K. → INSPECTION END

N.G.

B CHECK HARNESS CONTINUITY BETWEEN E.C.U. AND EXHAUST GAS TEMPERATURE SENSOR

- 1) Stop engine.
- 2) Disconnect E.C.U. 15-pin terminal connector.
- 3) Disconnect exhaust gas temperature sensor harness connector.
- 4) Check continuity between E.C.U. terminal 111 and a.

N.G. →

- 1) Check middle harness connector connection.
- 2) If necessary, repair or replace harness.

O.K.

C CHECK GROUND CIRCUIT

Check continuity between b and ground.

Resistance:

Approximately 0Ω

N.G. →

- 1) Check middle harness connector connection.
- 2) If necessary, repair or replace harness.

O.K.

↓

⊕

EXHAUST GAS TEMPERATURE SENSOR (Code No. 35)  (CHECK ENGINE LIGHT ITEM); CALIFORNIA MODEL ONLY

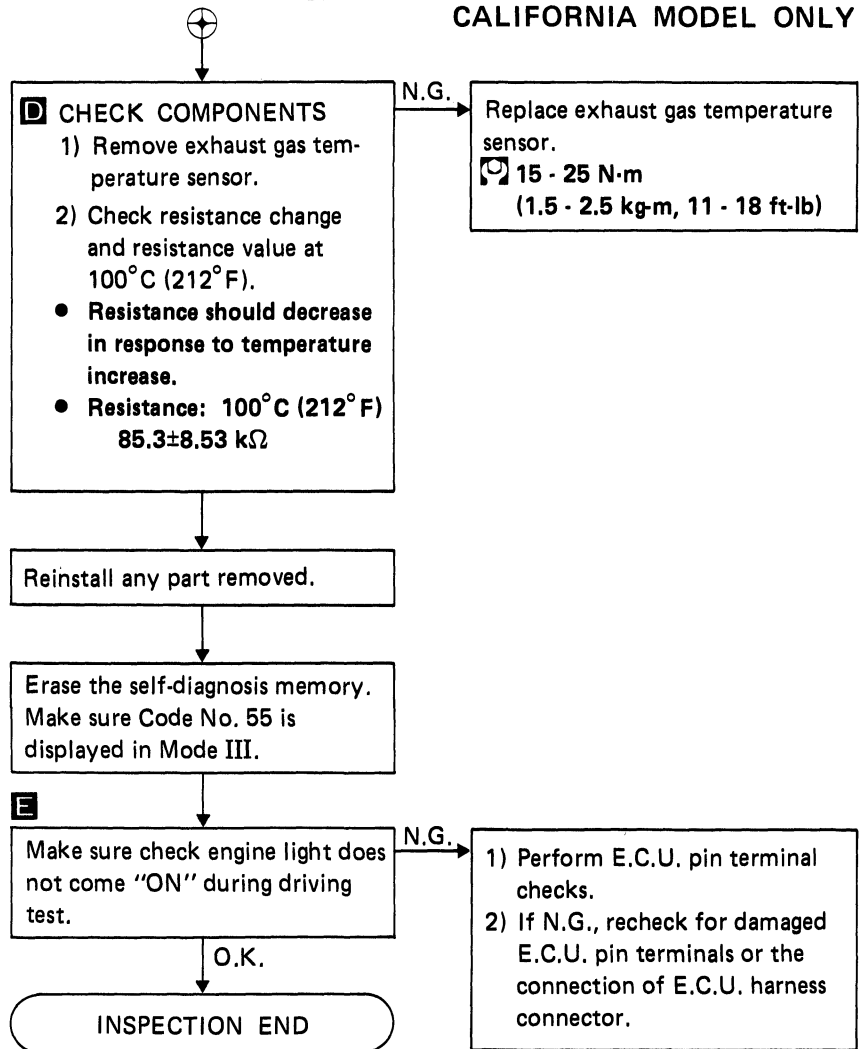

NOTE

THROTTLE SENSOR (Code No. 43)  (CHECK ENGINE LIGHT ITEM)

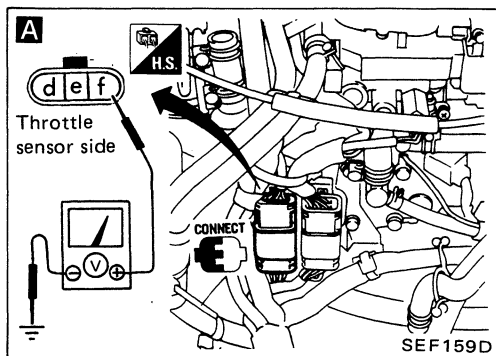
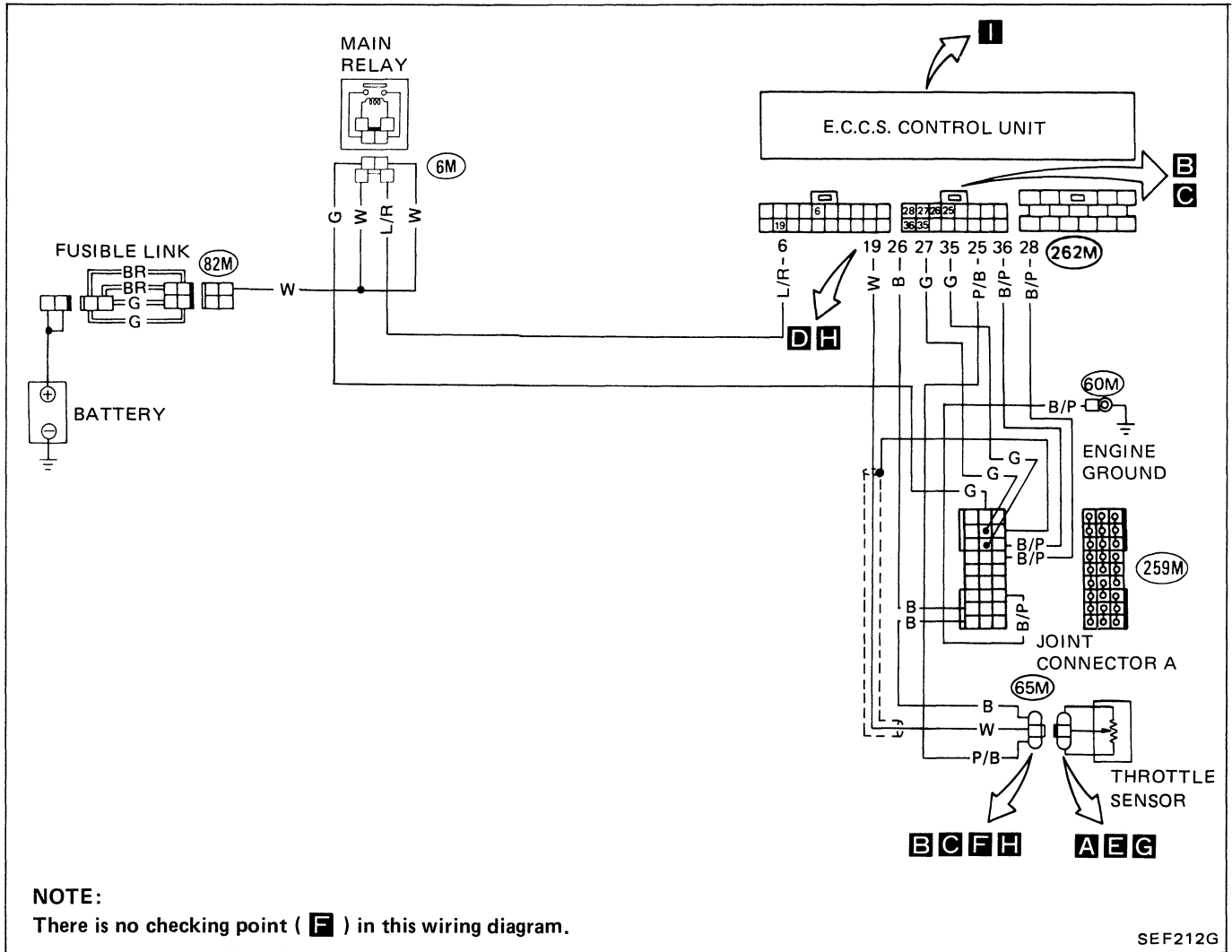

THROTTLE SENSOR (Code No.43)  (CHECK ENGINE LIGHT ITEM)

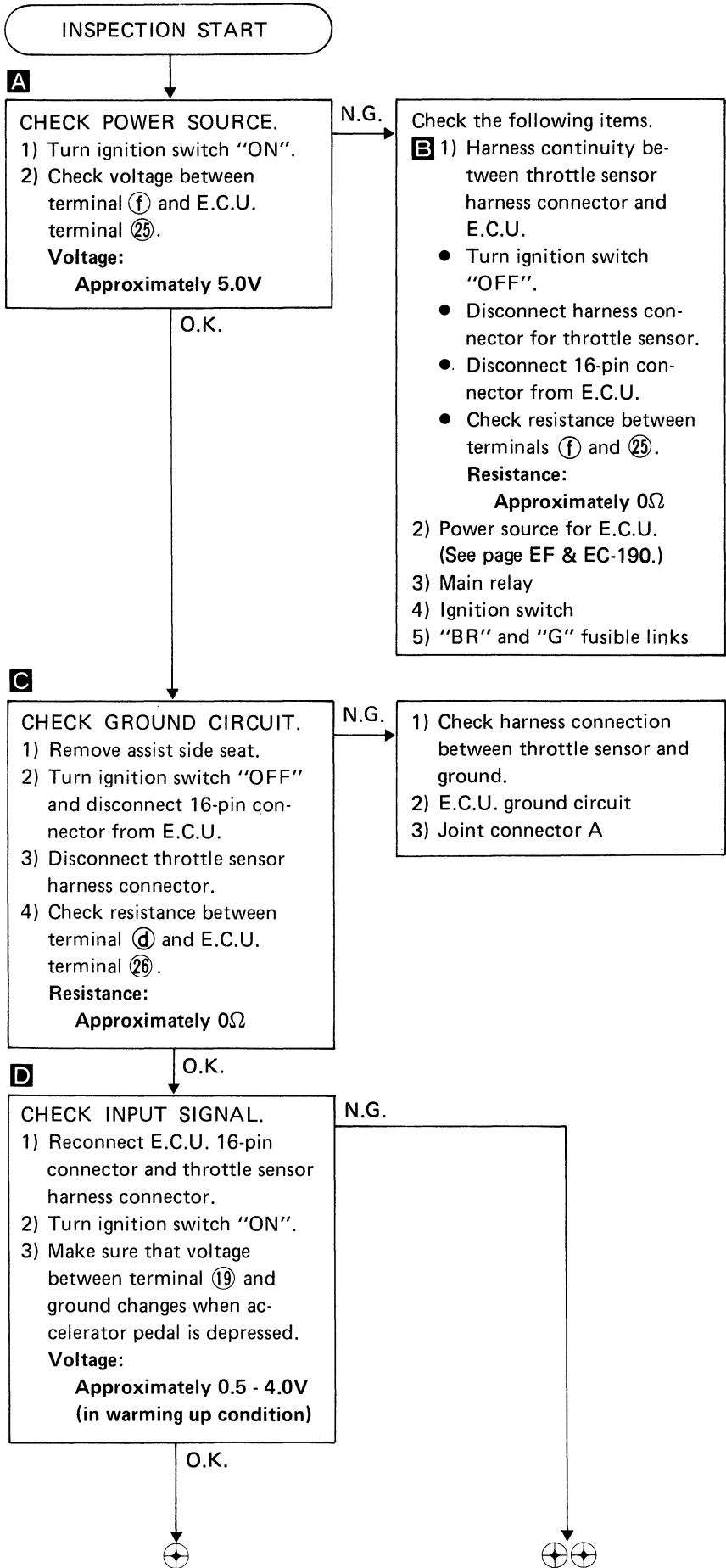
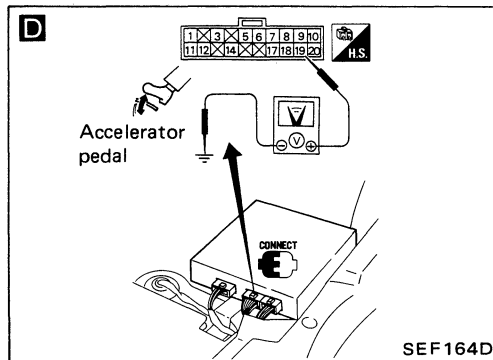
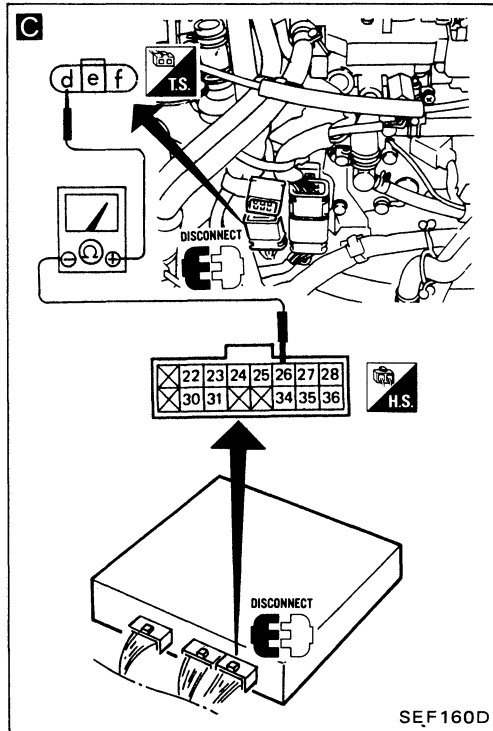
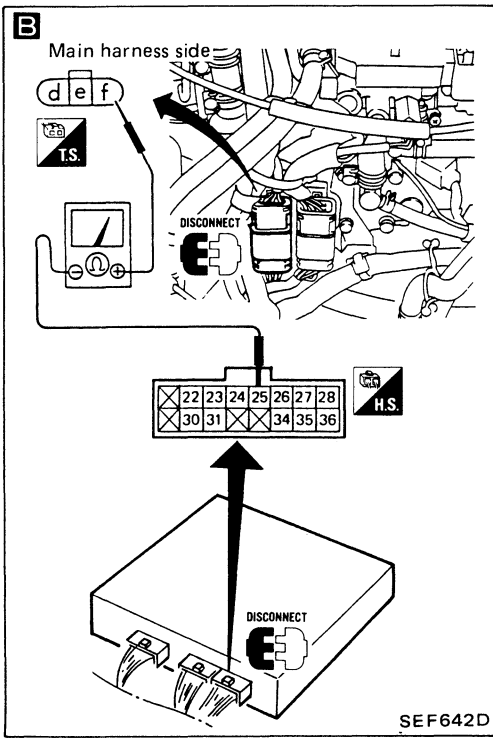

THROTTLE SENSOR (Code No. 43) (CHECK ENGINE LIGHT ITEM)

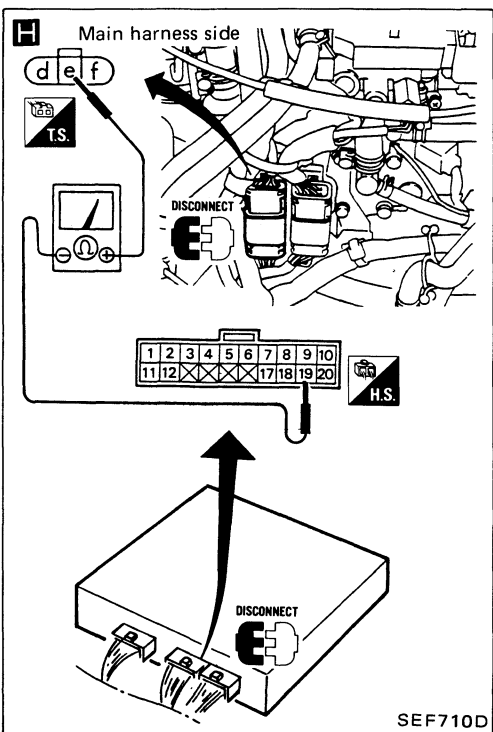
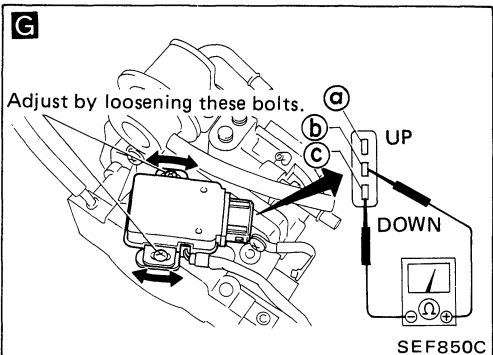
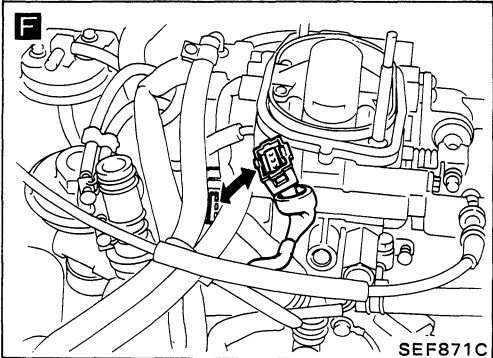
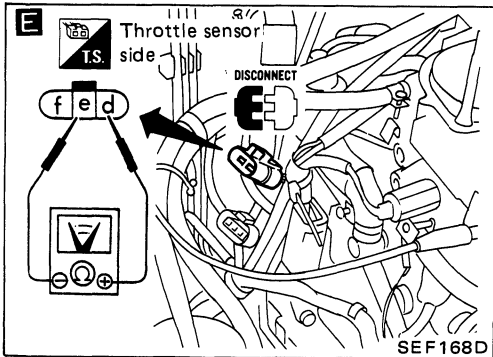

Reinstall any part removed.

- 1) Turn ignition switch "OFF" and disconnect throttle sensor harness connector.
- E** 2) Make sure that resistance between **d** and **e** changes when opening throttle valve manually. **Resistance should change.** If not, replace throttle sensor.
- 3) Check idle switch OFF → ON speed.
 - Reconnect throttle sensor harness connector.
 - Remove air cleaner.
 - Put a suitable plug into disconnected vacuum hose.
- F** • Disconnect idle switch harness connector.
 - Start and warm up engine sufficiently.
 - Check idle switch OFF → ON speed with circuit tester, closing throttle valve manually.

Idle switch OFF → ON speed:

1,600 ⁺⁵⁵⁰ ₋₂₅₀ rpm

(A/T: in "N" position)
- G** • If N.G., loosen throttle sensor installing screws, then set idle switch OFF → ON speed to the specified value by turning throttle sensor body. (Connect circuit tester with terminals **b** and **c** on idle switch side and find out OFF → ON point.)
 - Tighten throttle sensor installing screws after setting.
- H** 4) Check harness continuity between throttle sensor and E.C.U.
 - Disconnect throttle sensor harness connector.
 - Disconnect 20-pin connector from E.C.U.
 - Check resistance between terminal **e** and E.C.U. terminal **19**.

Resistance:

Approximately 0Ω

THROTTLE SENSOR (Code No. 43) (CHECK ENGINE LIGHT ITEM)

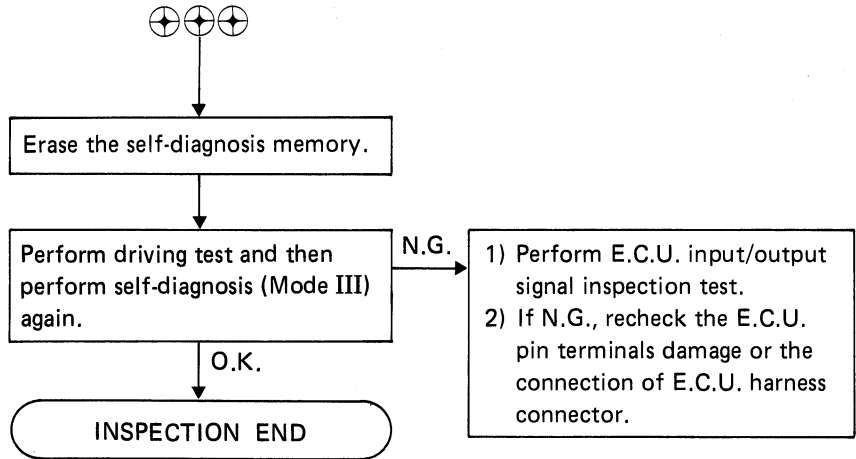

INJECTOR LEAK (Code No. 45) HC_{CHECK} (CHECK ENGINE LIGHT ITEM); CALIFORNIA MODEL ONLY

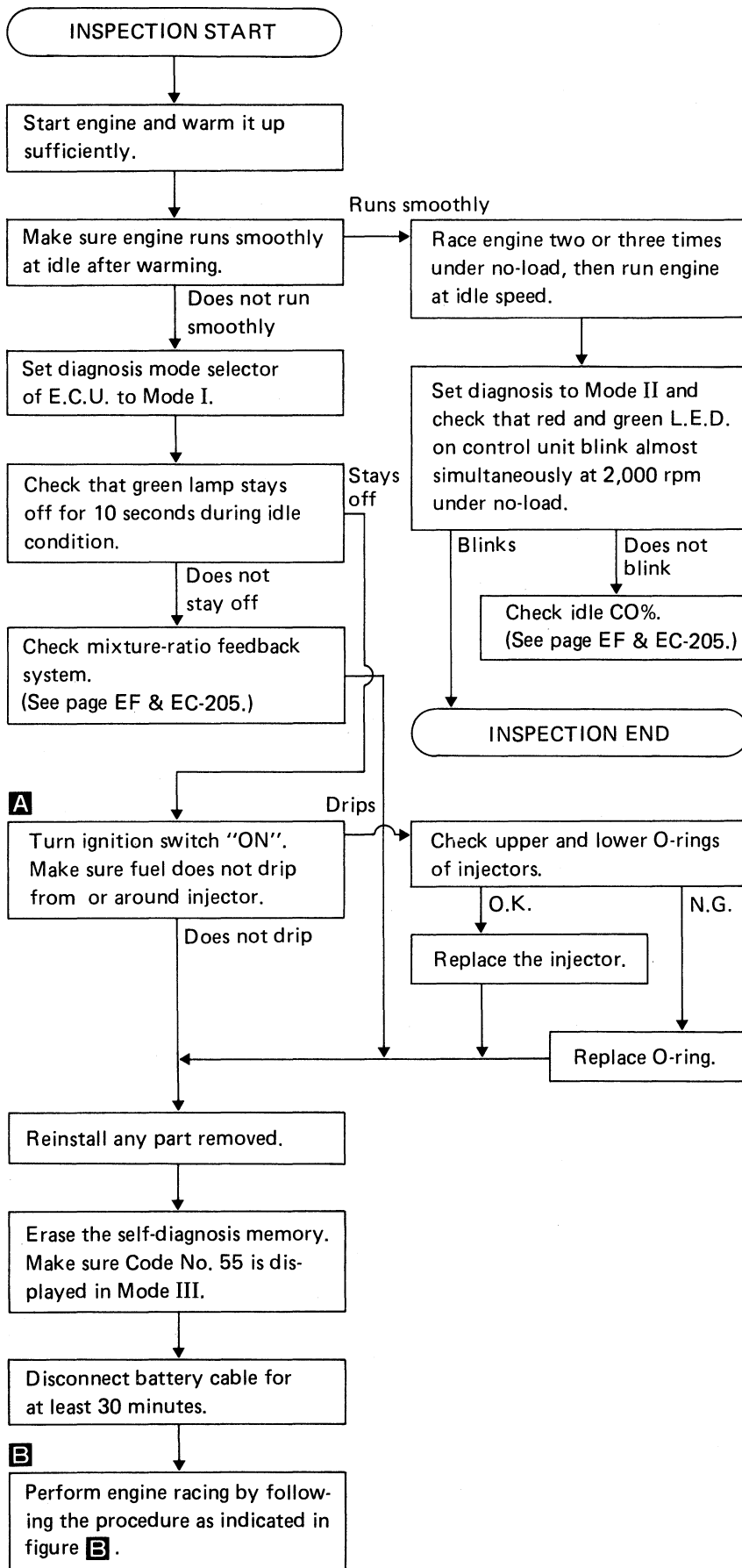
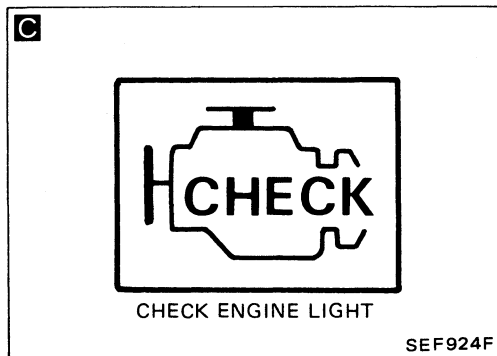
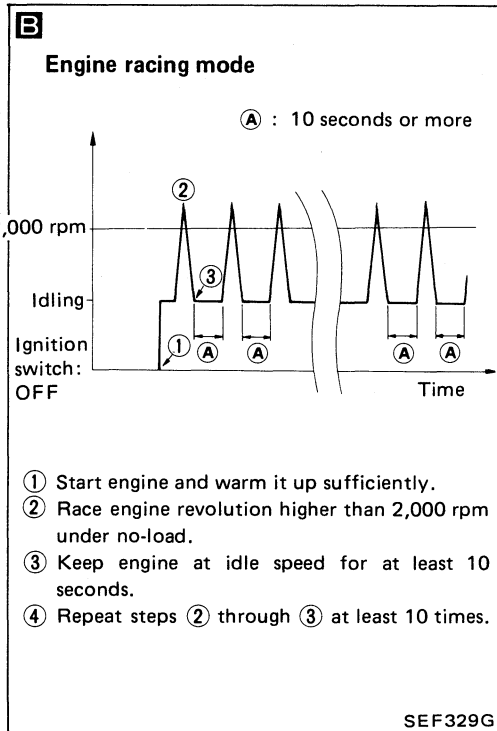
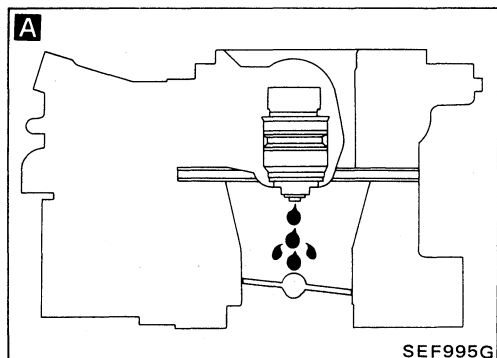

INJECTOR LEAK (Code No. 45) (CHECK ENGINE LIGHT ITEM); CALIFORNIA MODEL ONLY

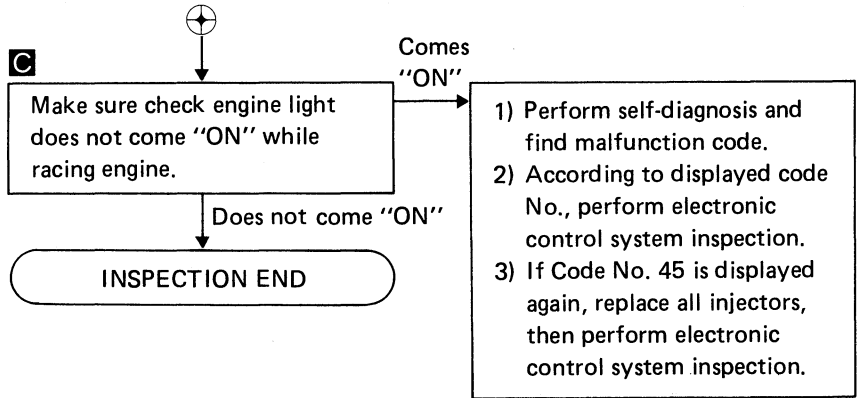

IDLE SWITCH (Switch ON/OFF diagnosis)

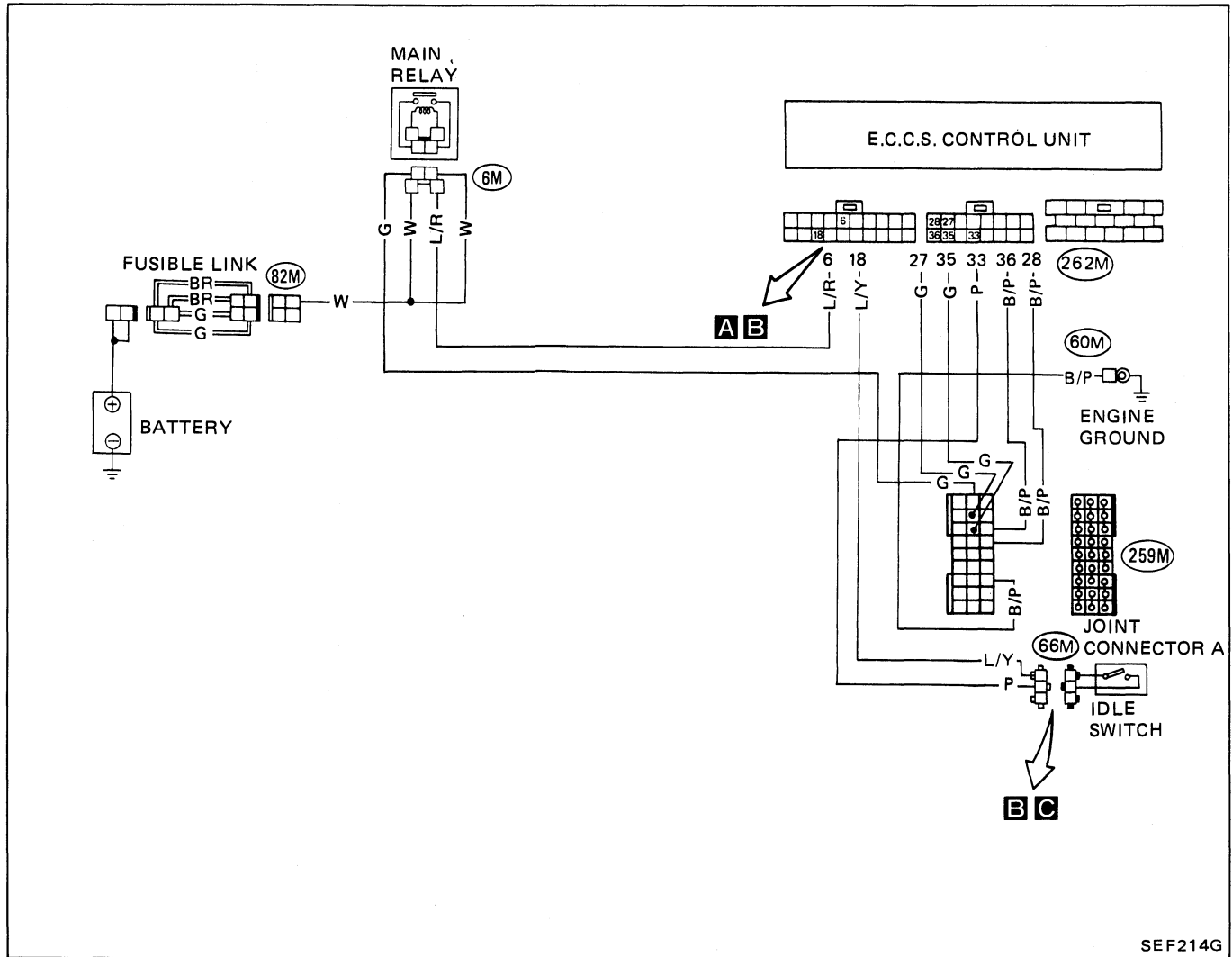

SEF214G

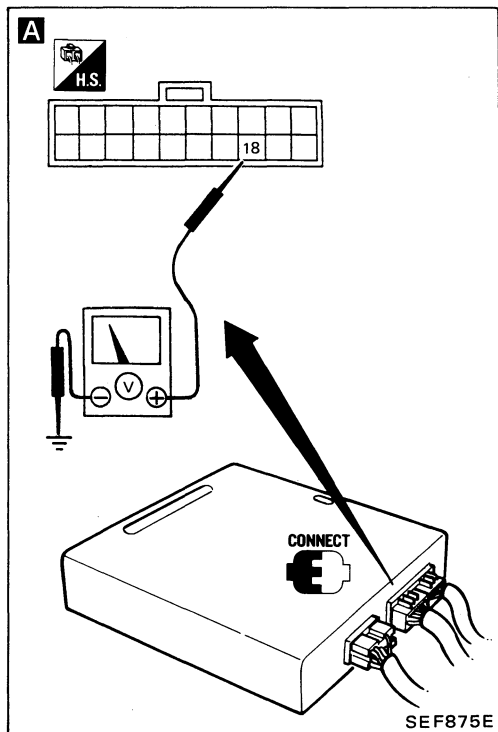

SEF875E

IDLE SWITCH (Switch ON/OFF diagnosis)

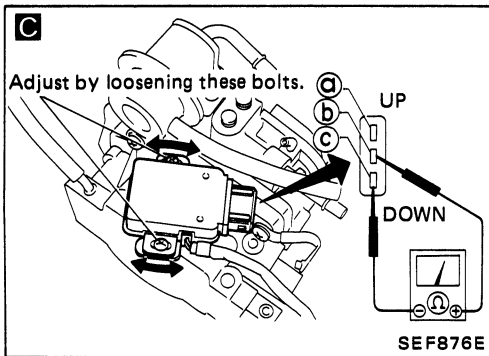
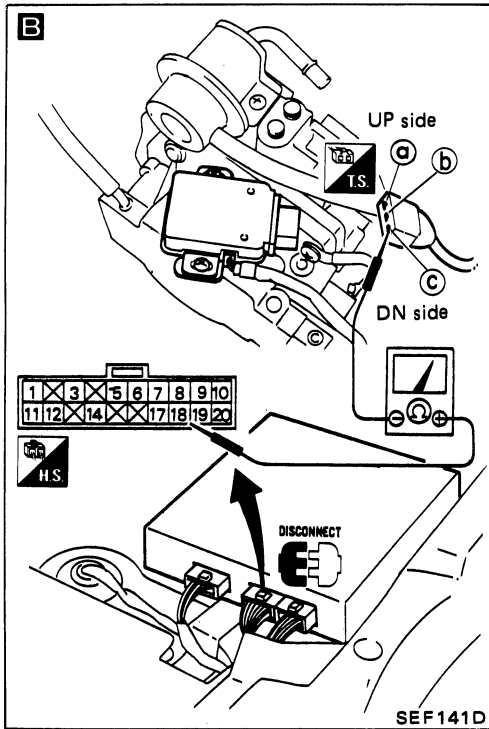

INSPECTION START

A

CHECK INPUT SIGNAL.
 1) Turn ignition switch "ON".
 2) Check voltage between E.C.U. terminals (18) and ground.

Accel. pedal condition	Voltage
Fully closed	Approximately 5.0V
Open	0V

N.G. →

Check the following items.

B 1) Harness continuity between E.C.U. and throttle valve switch.

- Disconnect 20-pin connector from E.C.U.
- Disconnect idle switch harness connector.
- Check resistance between E.C.U. terminal (18) and terminal (c).

Resistance:
Approximately 0Ω

C 2) Continuity of idle switch.

- Disconnect idle switch harness connector.
- Check resistance between terminals (a) and (b) when idle switch closes fully.

Resistance:
Approximately 0Ω

- Check resistance between terminals (a) and (c) when idle switch opens fully.

Resistance:
Approximately 0Ω

3) Power source and ground circuit for E.C.U.
 (See page EF & EC-190.)

O.K. ↓

Perform switch ON/OFF diagnosis (Mode-IV).

N.G. →

- 1) Perform E.C.U. input/output signal inspection test.
- 2) If N.G., recheck the E.C.U. pin terminals damage or the connection of E.C.U. harness connector.

O.K. ↓

INSPECTION END

STARTER SWITCH (Switch ON/OFF diagnosis)

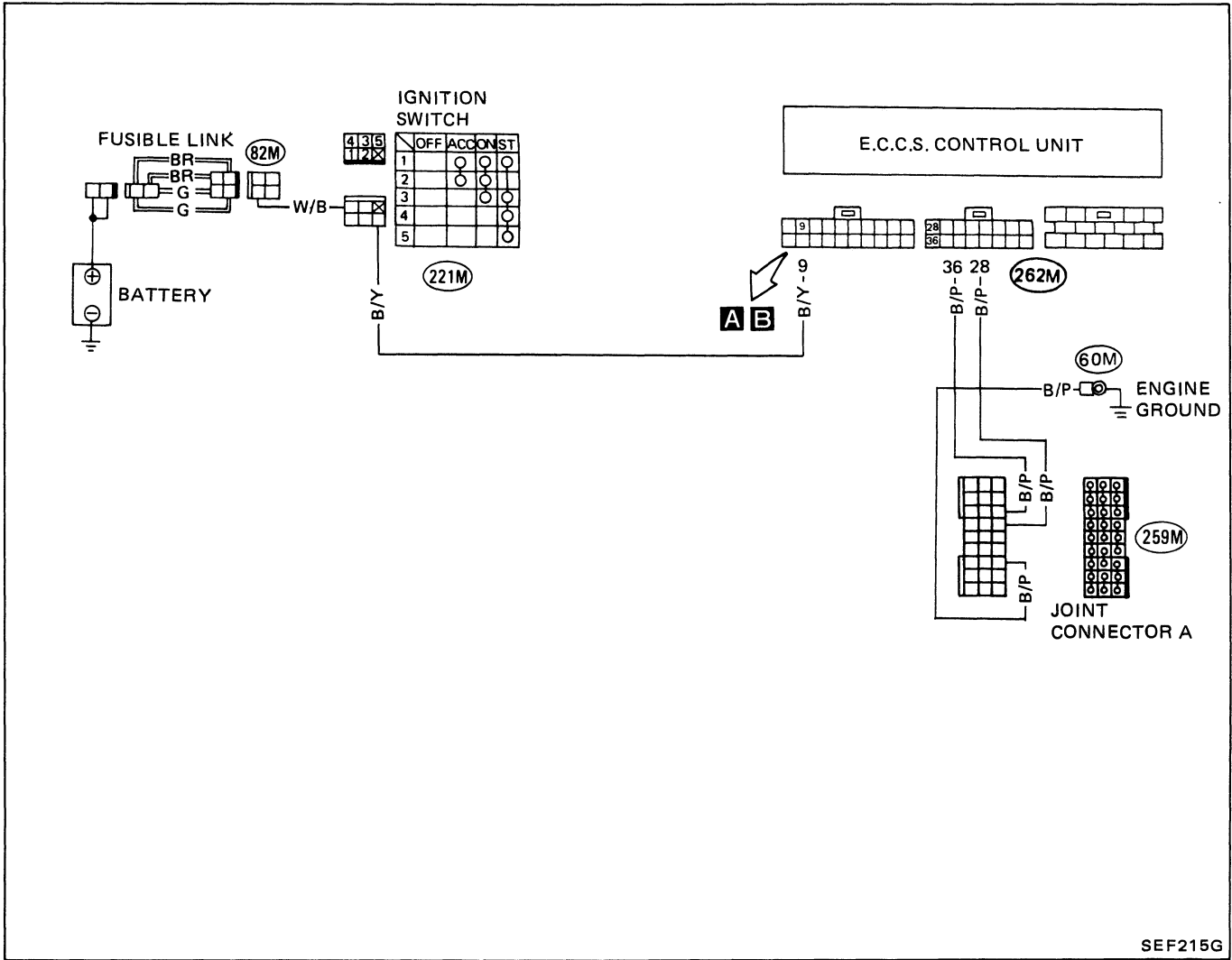

STARTER SWITCH (Switch ON/OFF diagnosis)

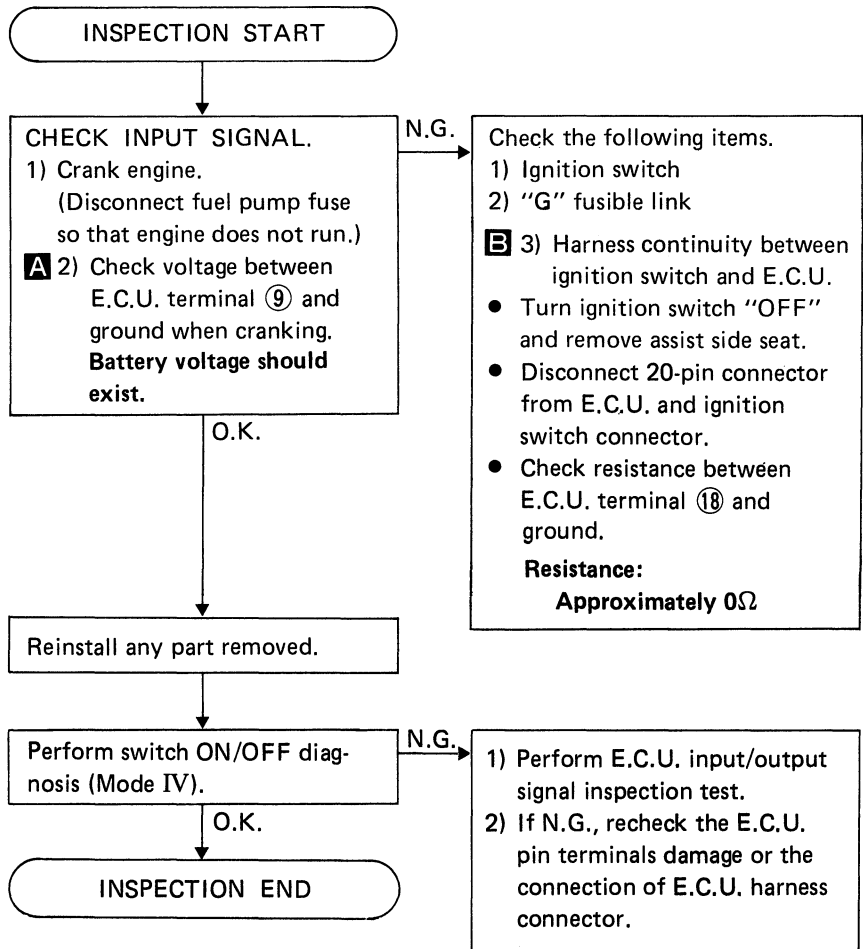
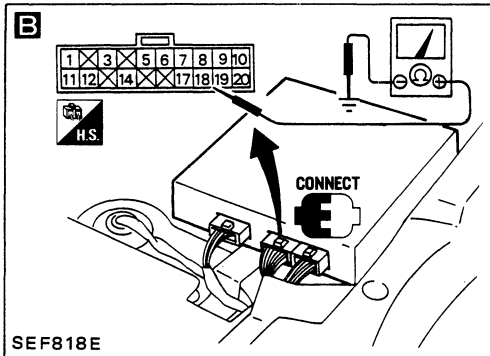
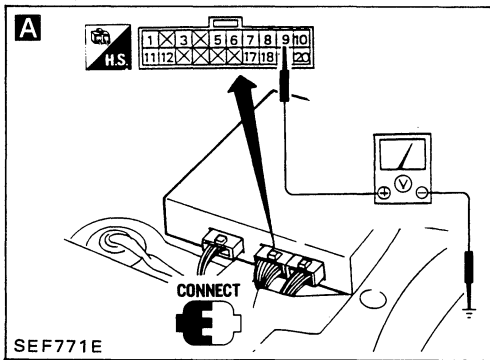

NEUTRAL/CLUTCH/INHIBITOR SWITCH (Not self-diagnostic item)

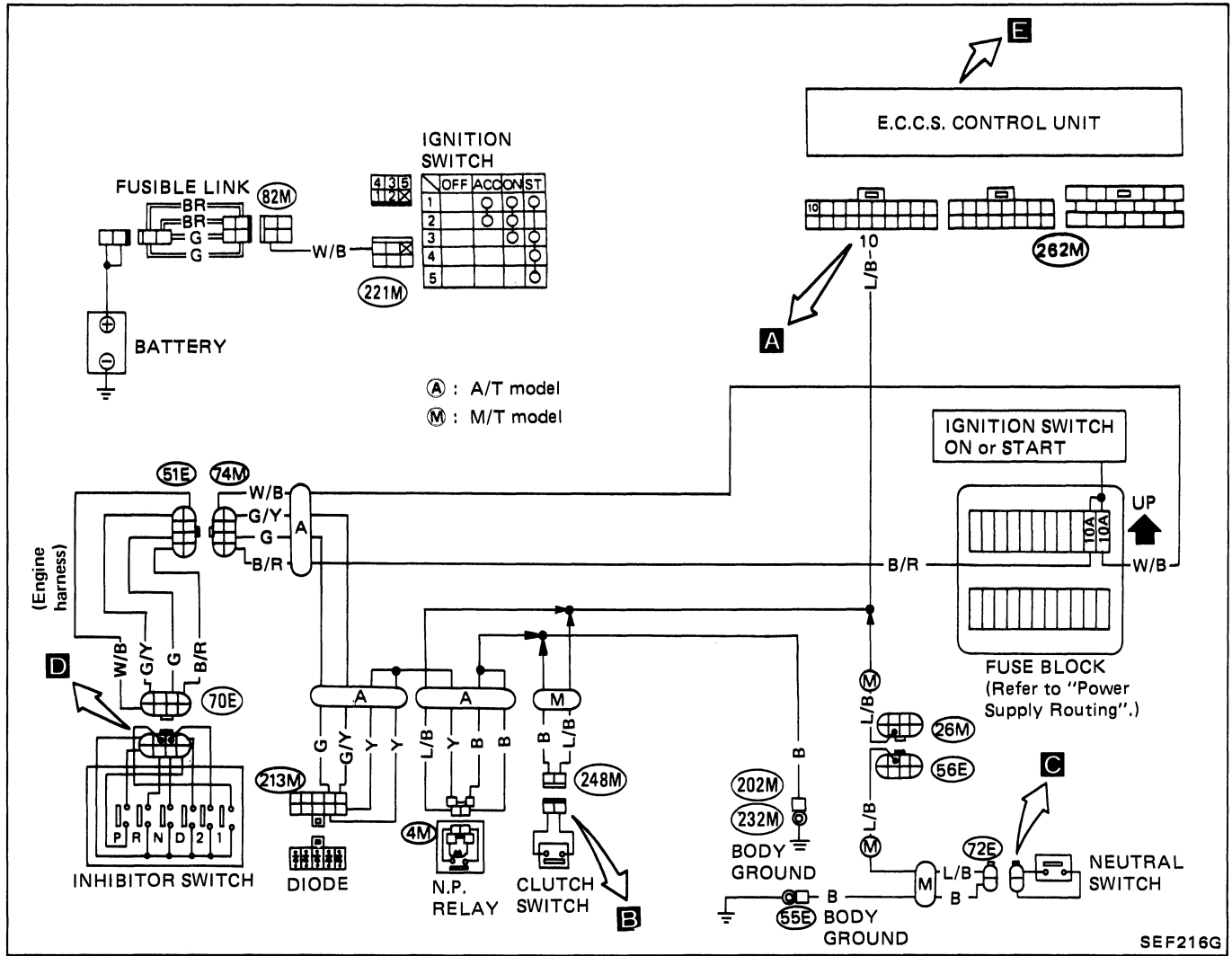

SEF216G

NEUTRAL/CLUTCH/INHIBITOR SWITCH (Not self-diagnostic item)

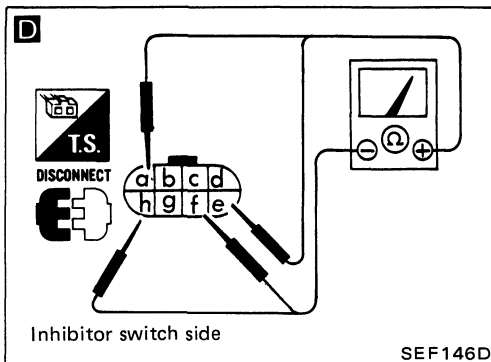
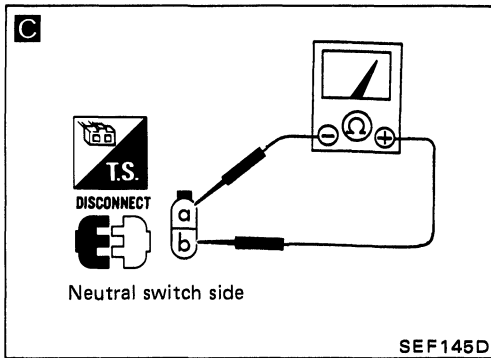
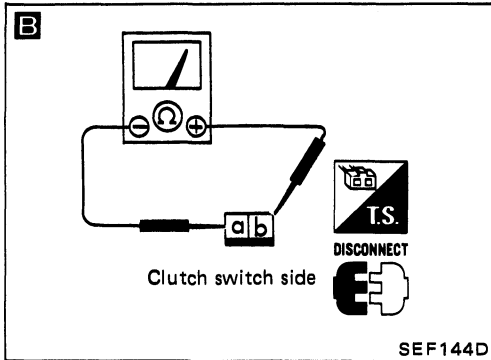
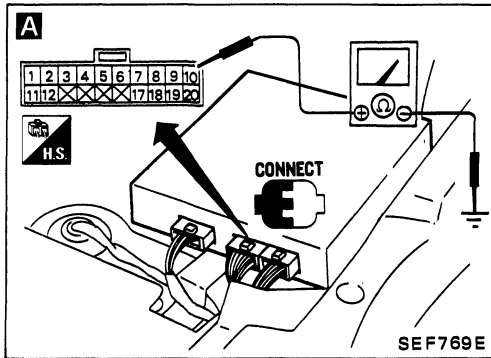

INSPECTION START

A CHECK INPUT SIGNAL.
Check continuity between E.C.U. connector terminal ⑩ and ground.
Continuity should be as shown below.

N.G.

M/T model

Gear position \ Clutch condition	Engaged	Dis-engaged
	Neutral	0Ω
Others	∞Ω	0Ω

A/T model

• Turn ignition switch "ON".

Gear position	Resistance
N or P	0Ω
Others	∞Ω

O.K.

Reinstall any part removed.

INSPECTION END

Check the following items.

- M/T model**
- 1) Harness continuity between E.C.U. and ground.
 - B** 2) Continuity of clutch switch
 - Disconnect harness connector for clutch switch.
 - Depress clutch pedal.
 - Check continuity between terminals ㉑ and ㉒.**Continuity should exist.**
If not, replace clutch switch.
 - C** 3) Continuity of neutral switch
 - Disconnect harness connector for neutral switch.
 - Shift manual transmission lever to neutral.
 - Check continuity between terminals ㉑ and ㉒.**Continuity should exist.**
If not, replace neutral switch.
- A/T model**
- 1) Turn ignition switch "OFF".
 - 2) Harness continuity between E.C.U. and ground, ignition switch and ground.
 - D** 3) Continuity of inhibitor switch.
 - Disconnect harness connector for inhibitor switch.
 - Shift automatic transmission lever to "P" or "N".
 - Check continuity between terminals ㉑ and ㉒ - ㉓ and ㉔.**Continuity should exist.**
 ㉑ and ㉒ : "N",
 ㉓ and ㉔ : "P"
 If not, replace inhibitor switch.
 - 4) N.P. relay.
 - 5) Ignition switch
 - 6) Fuse

INJECTOR (Not self-diagnostic item)

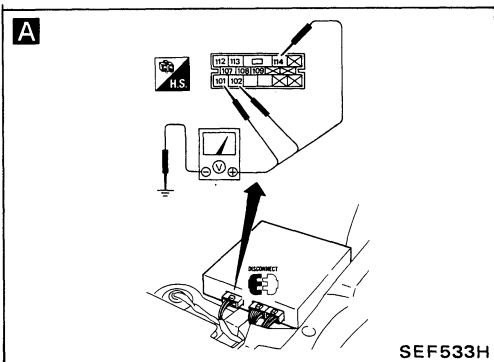
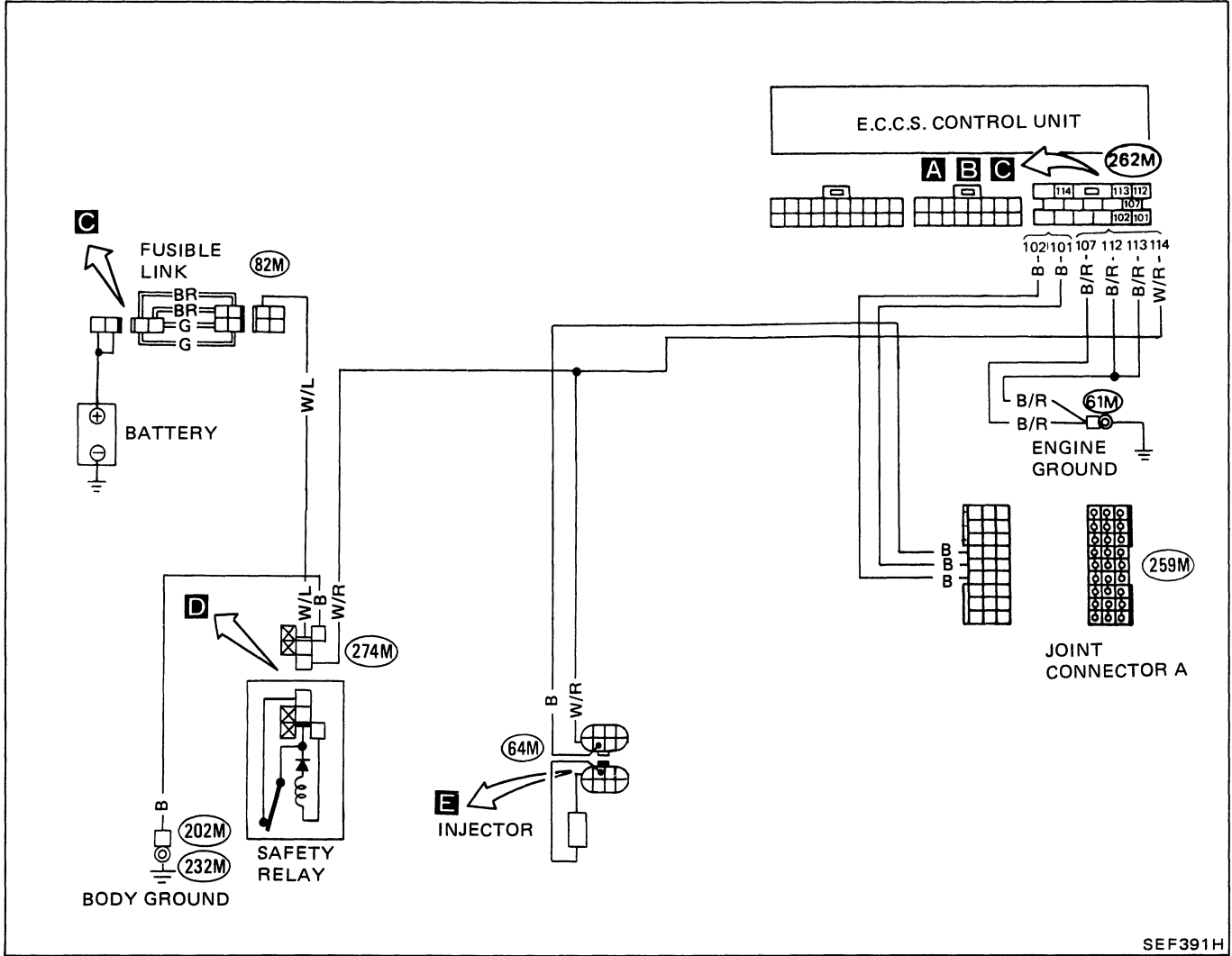

INJECTOR (Not self-diagnostic item)

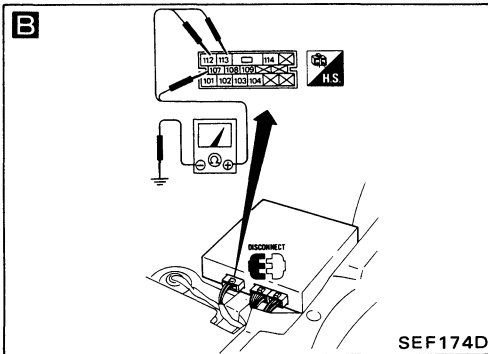

INSPECTION START

CHECK POWER SOURCE.
 1) Remove assist side seat.
 2) Disconnect 15-pin connector.
A 3) Check voltage between terminals (101), (102), (114) and ground.
Battery voltage should exist.

N.G. → Check the following items.
 1) Harness continuity between E.C.U. and battery
 • Disconnect battery "W/L" connector.
C • Check resistance between "WL" connector and E.C.U.
Resistance between (101), (102) and "W/L" connector
Resistance:
Approximately 1.5Ω
Resistance between (114) and "W/L" connector.
Resistance:
Approximately 0Ω

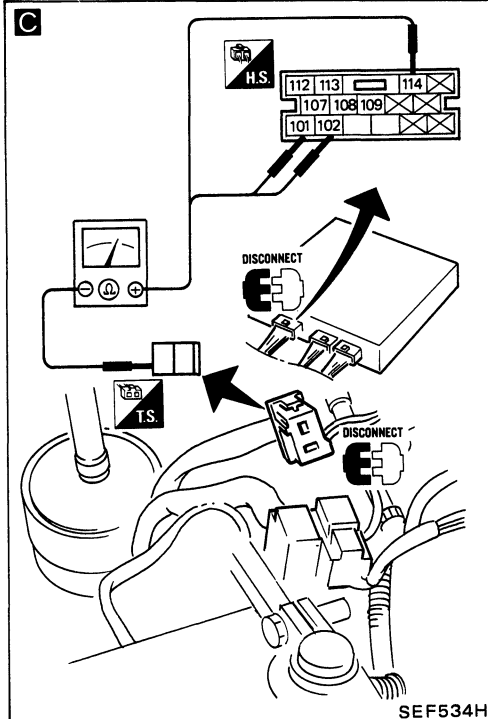

O.K. → **CHECK GROUND CIRCUIT.**
 1) Disconnect 15 pin connector from E.C.U.
 2) Check resistance between (107), (112), (113) and ground.
Resistance:
Approximately 0Ω

N.G. → **D** 2) Safety relay
 • Disconnect safety relay and check it as follows.

12V direct current is applied between terminal ① and ②.		Continuity between terminal ② and ③.
①	②	
-	+	Yes
+	-	No

O.K. → Reinstall any part removed.

- 3) Joint connector A
- 4) Harness connector for injector
- 5) "BR" fusible link

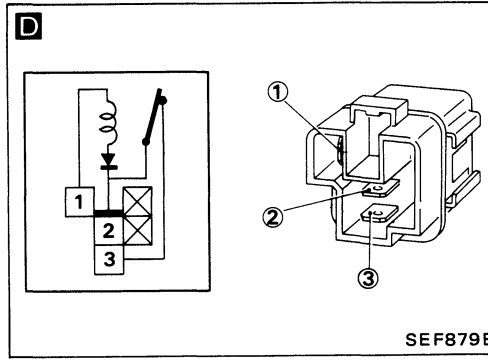

N.G. → **E** Check resistance of injector.
 • Disconnect injector harness connector.
Resistance:
Approximately 1.5Ω

N.G. → Replace injector.

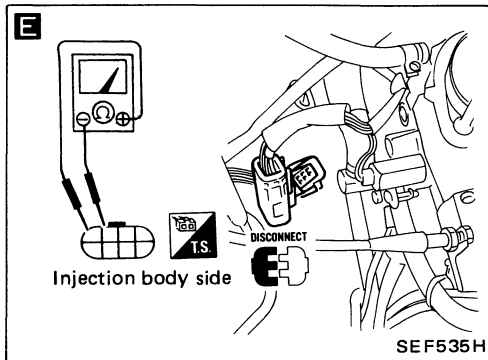

- 1) Perform E.C.U. input/output signal inspection test.
- 2) If N.G., recheck the E.C.U. pin terminals damage or the connection of E.C.U. harness connector.

INSPECTION END

MIXTURE HEATER (Not self-diagnostic item)

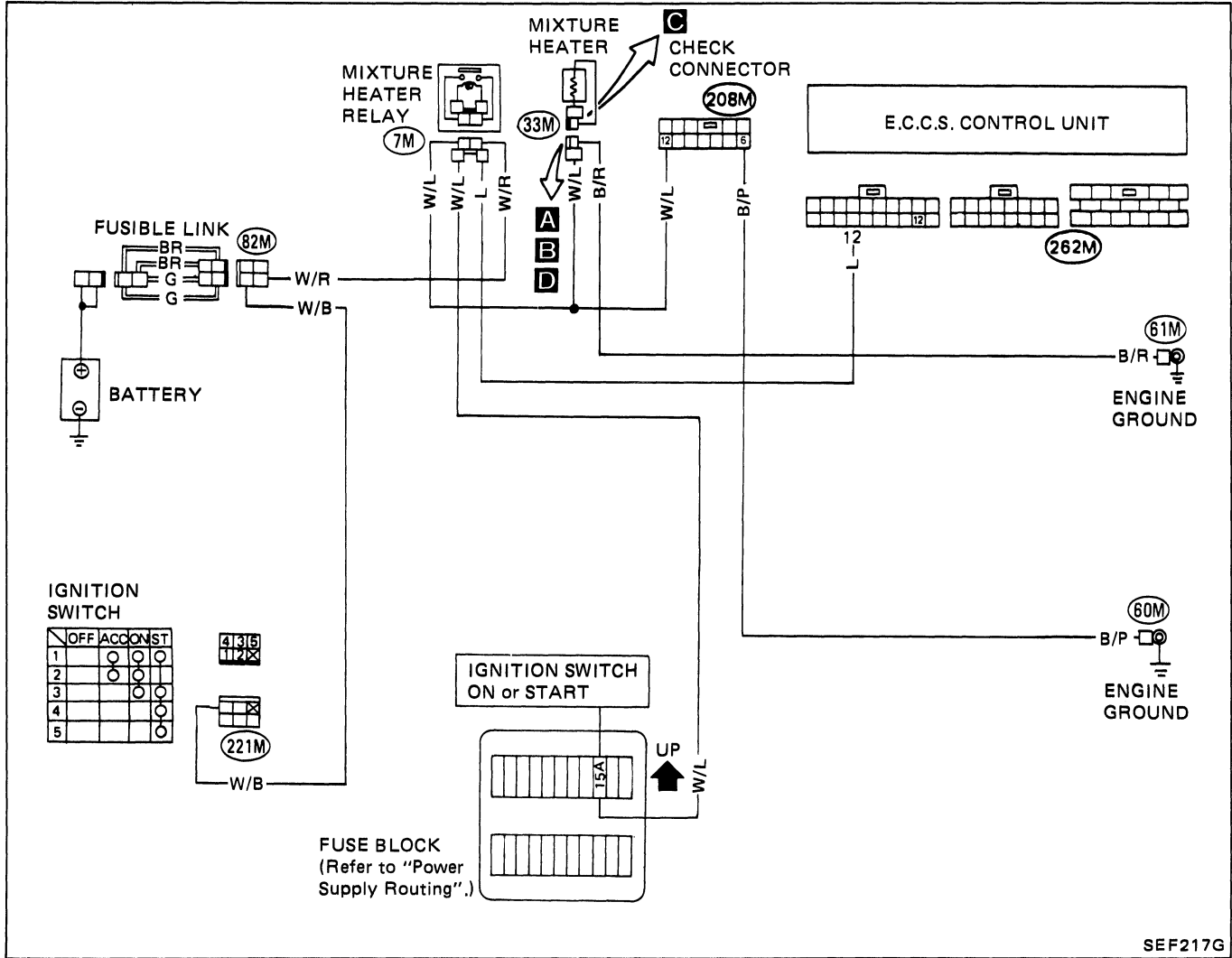

SEF217G

MIXTURE HEATER (Not self-diagnostic item)

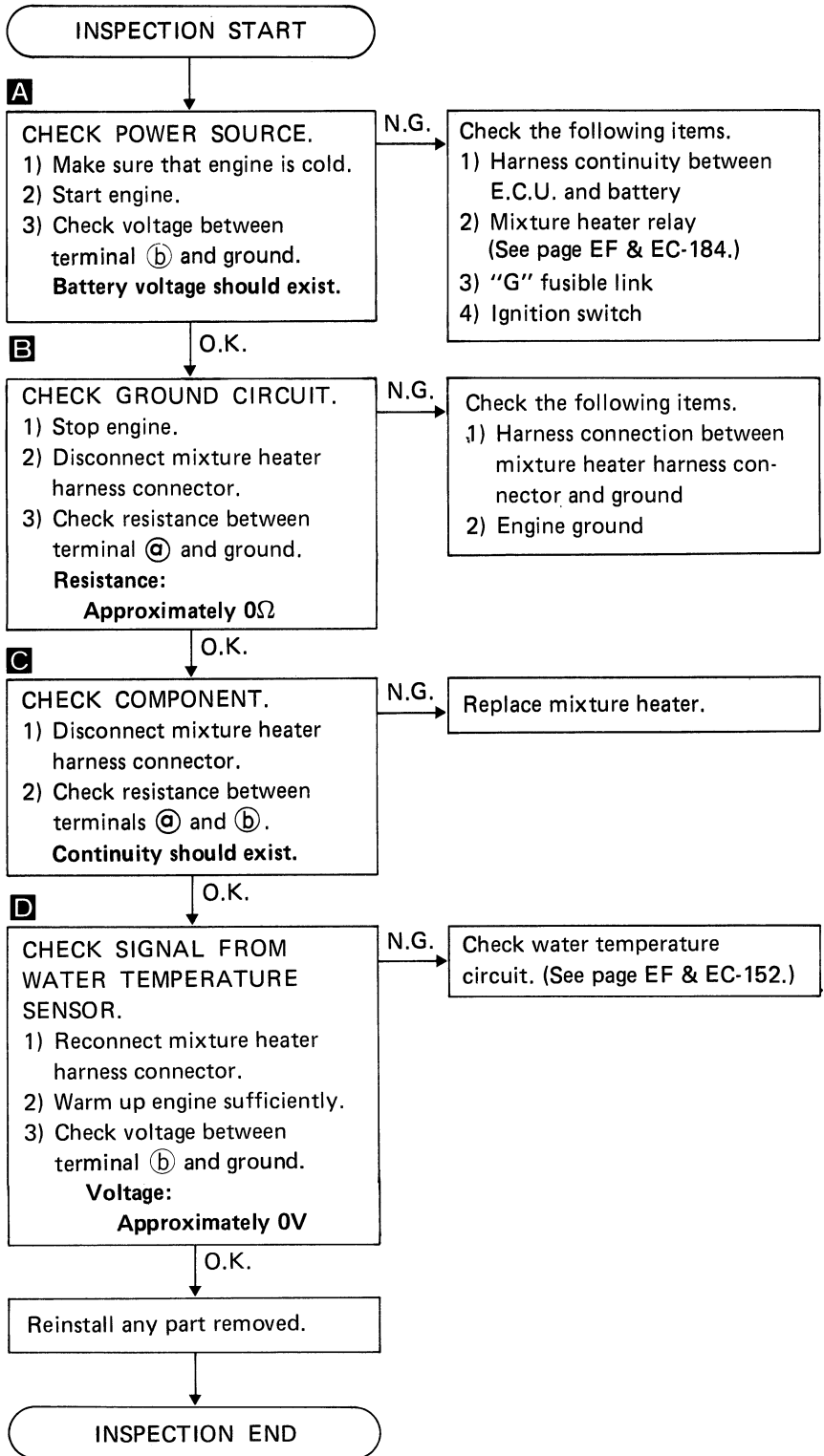
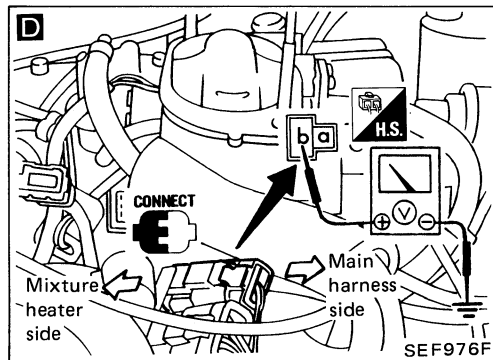
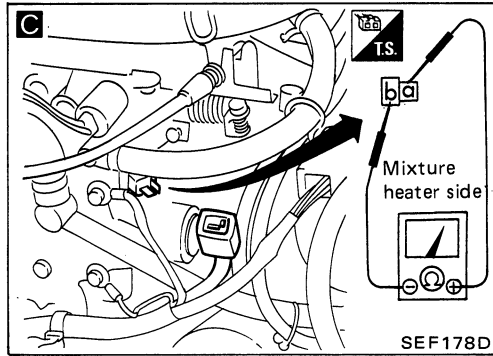
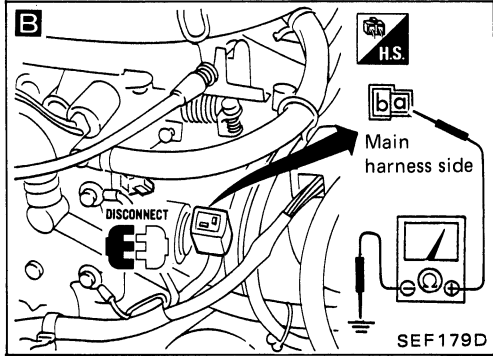
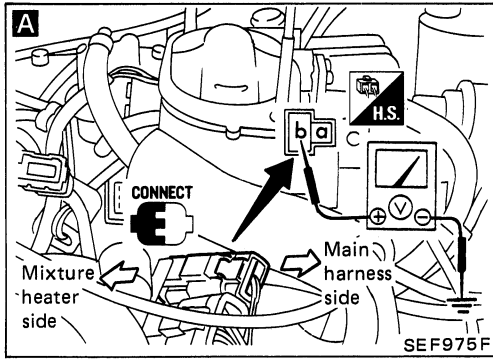

MIXTURE HEATER RELAY (Not self-diagnostic item)

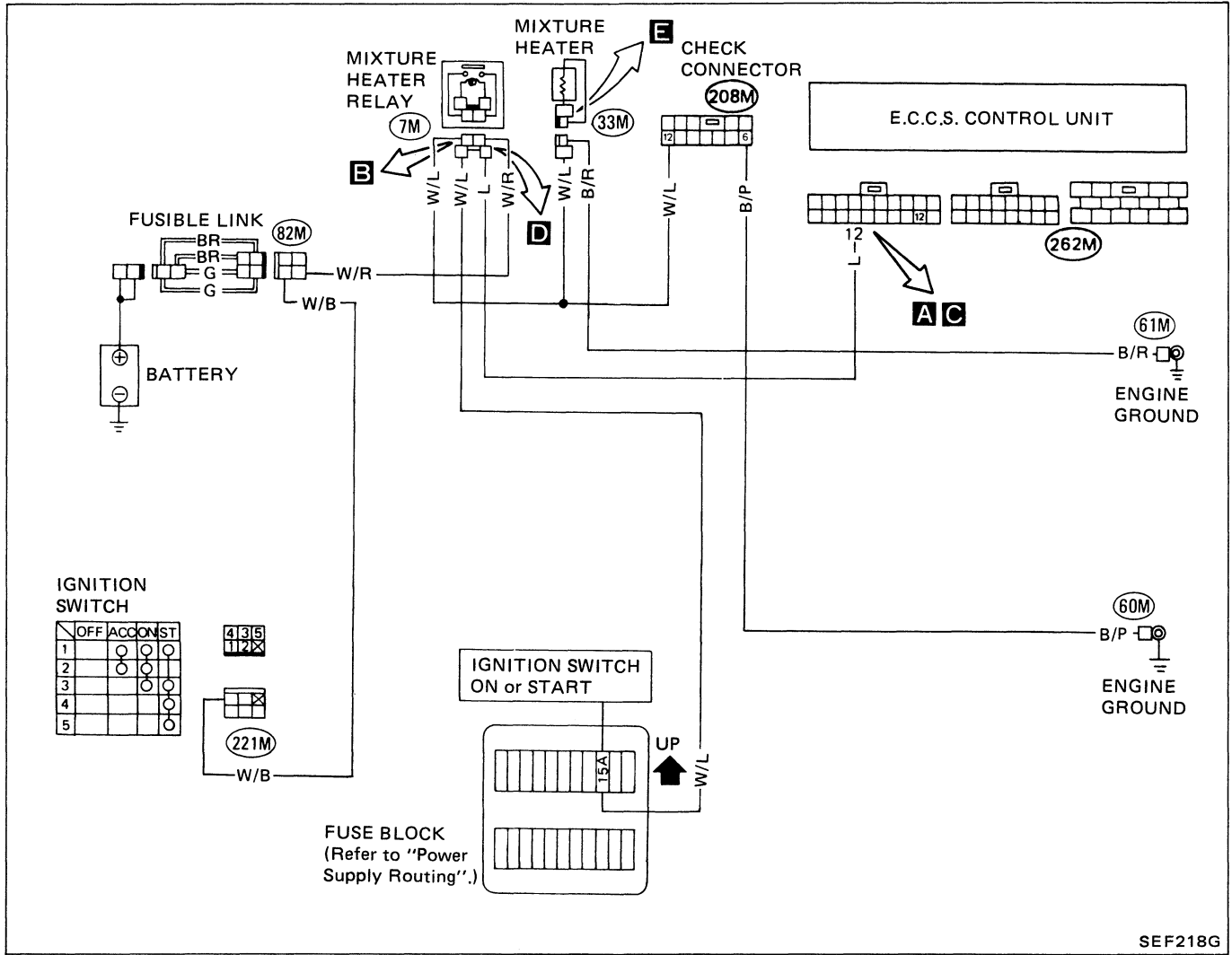

SEF218G

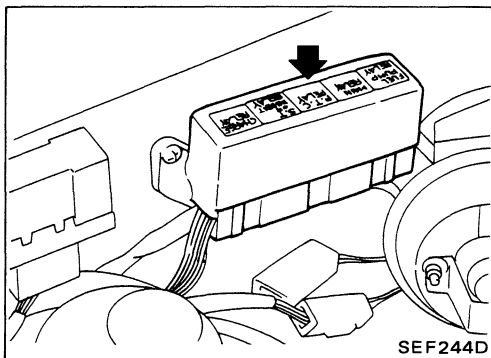

Mixture heater relay location

MIXTURE HEATER RELAY (Not self-diagnostic item)

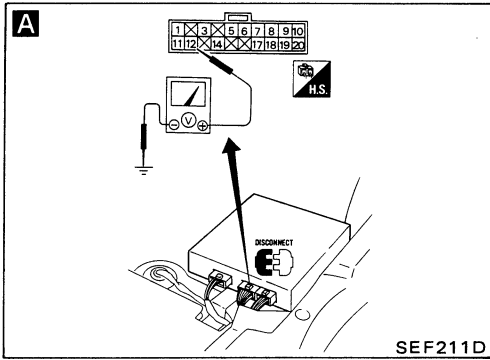

- 1) Turn ignition switch "OFF".
- 2) Disconnect 20-pin connector from E.C.U.
- 3) Turn ignition switch "ON".
- A** 4) Check voltage between terminal ⑫ and ground.
Battery voltage should exist.

- N.G. →
- 1) Turn ignition switch "OFF".
 - 2) Remove mixture heater relay.
 - B** 3) Connect terminals ① and ② with a suitable jumper wire.
 - 4) Turn ignition switch "ON".
 - A** 5) Recheck voltage between terminal ⑫ and ground.
Battery voltage should exist.

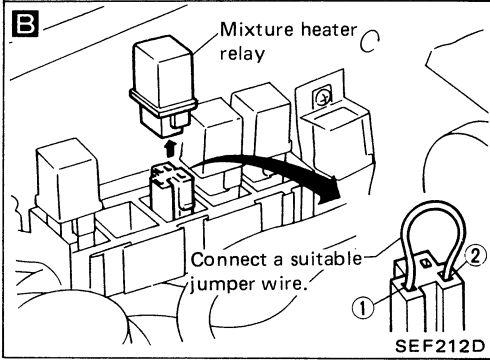

- O.K. ↓
- 1) Turn ignition switch "OFF".
 - C** 2) Connect terminal ⑫ to ground using a suitable jumper wire.
 - 3) Turn ignition switch "ON".
 - E** 4) Check voltage between terminal ③ at mixture heater harness connector and ground.
Battery voltage should exist.

- O.K. ↓ N.G. ↓
- O.K. ↓

Replace mixture heater relay.

N.G. ↓

Check harness continuity between mixture heater relay and battery.

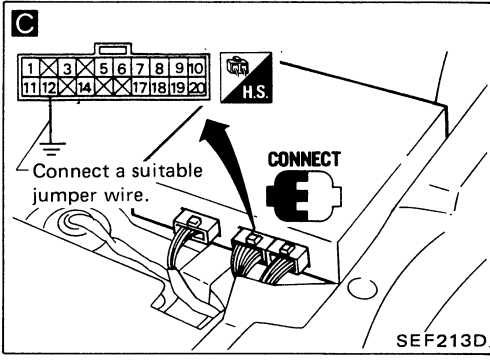

- N.G. →
- 1) Turn ignition switch "OFF".
 - 2) Remove mixture heater relay.
 - D** 3) Connect terminals ③ and ④ using a suitable jumper wire.
 - 4) Turn ignition switch "ON".
 - E** 5) Recheck voltage between terminal ③ at mixture heater harness connector and ground.
Battery voltage should exist.

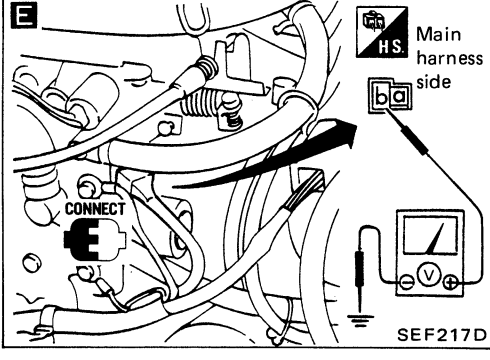
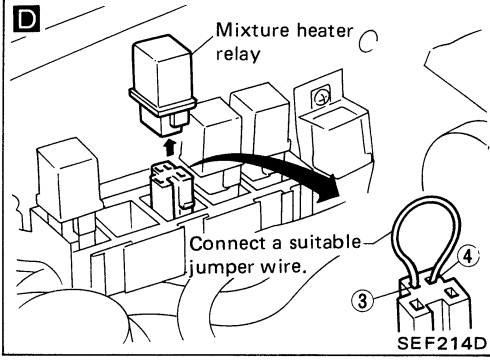

FUEL PUMP (Not self-diagnostic item)

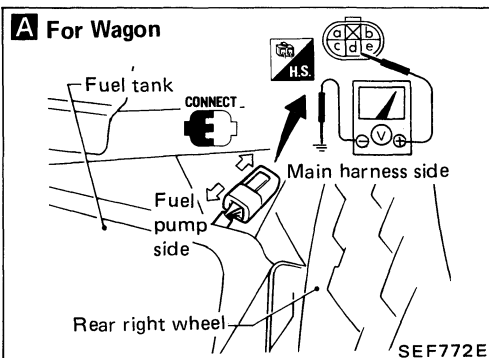
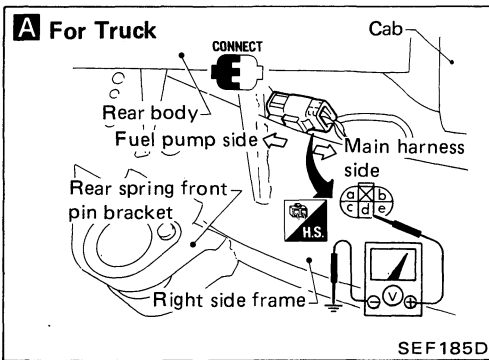
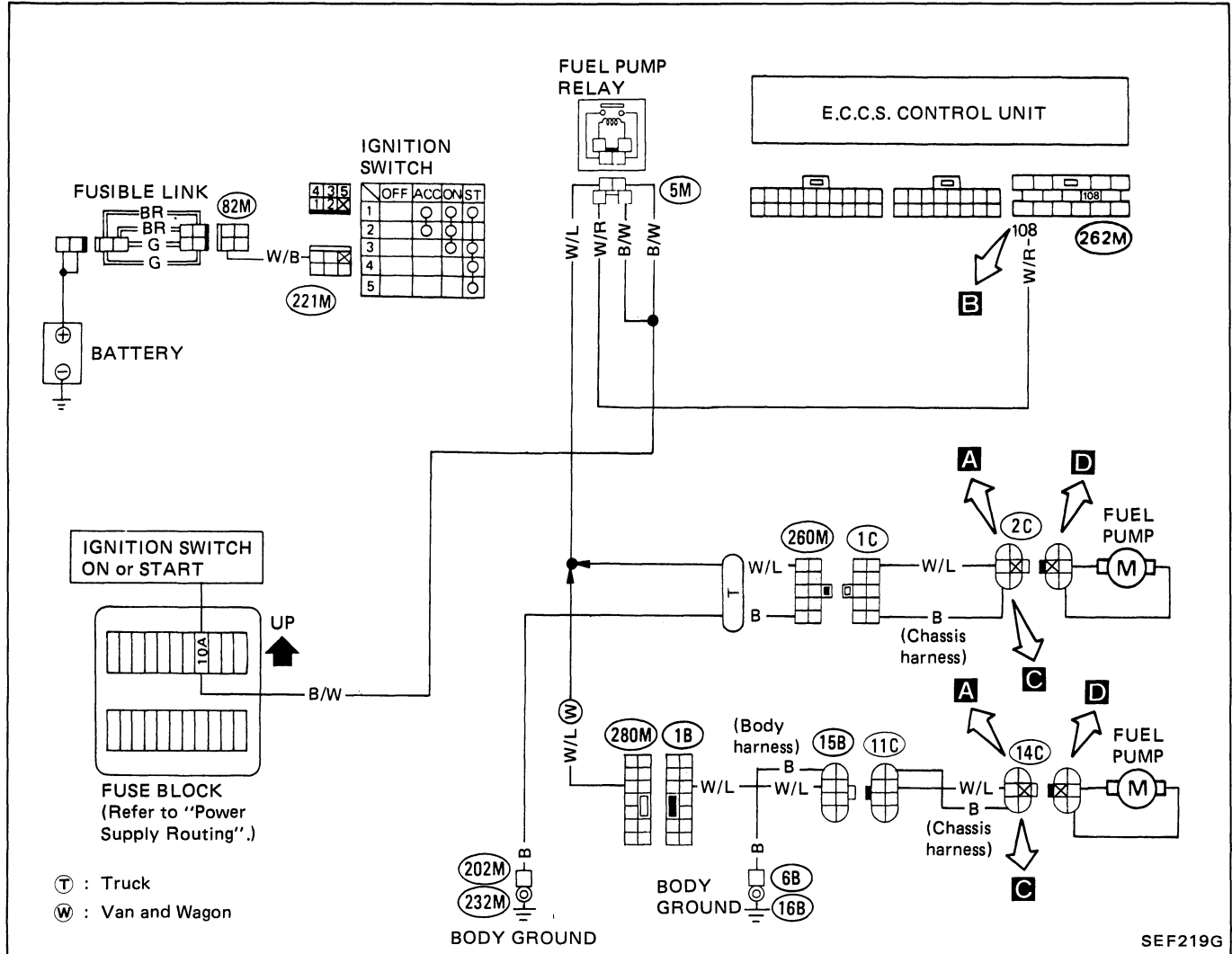

FUEL PUMP (Not self-diagnostic item)

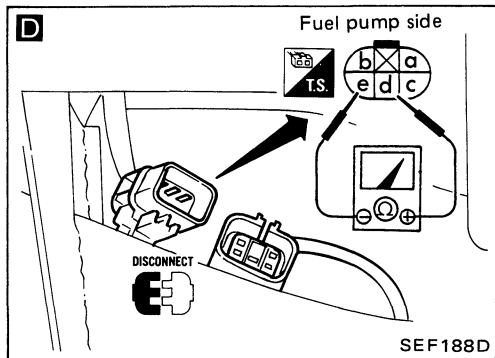
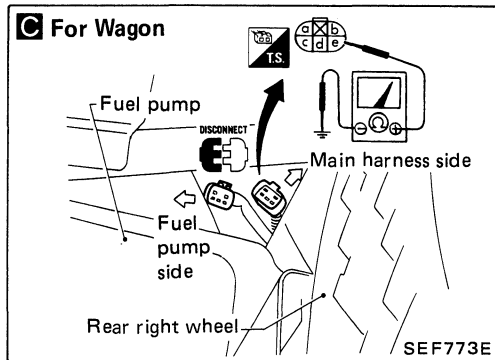
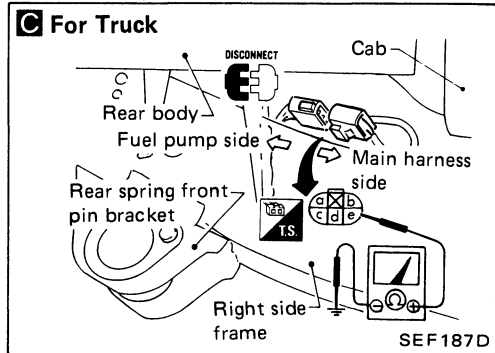
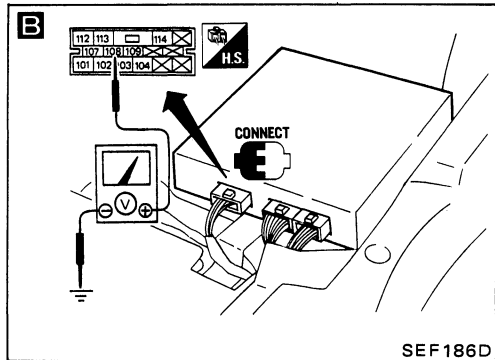

```

    graph TD
        Start([INSPECTION START]) --> A[CHECK POWER SOURCE.  
1) Turn ignition switch "ON".  
2) Check voltage between terminal ① and ground.  
Battery voltage should exist for 5 seconds after turning ignition switch "ON".]
        A -- N.G. --> A_NG[Check the following items.  
1) Harness continuity between fuel pump and ground  
2) Fuel pump relay (See page EF & EC-188.)  
3) "G" fusible link  
4) Power source to E.C.U.  
B • Turn ignition switch "OFF".  
• Remove assist side seat.  
• Turn ignition switch "ON".  
• Check voltage between terminal 108 and ground.  
Battery voltage should appear in 5 seconds after turning ignition switch "ON".]
        A -- O.K. --> C[CHECK GROUND CIRCUIT.  
1) Turn ignition switch "OFF".  
2) Disconnect fuel pump harness connector.  
3) Check resistance between terminal ② and ground.  
Resistance:  
Approximately 0Ω]
        C -- N.G. --> C_NG[Check harness connection between fuel pump harness connector and ground.]
        C -- O.K. --> D[CHECK COMPONENT.  
1) Disconnect fuel pump harness connector.  
2) Check resistance between terminal ③ and ④.  
Continuity should exist.]
        D -- N.G. --> D_NG[Replace fuel pump.]
        D -- O.K. --> E[Check crank angle sensor circuit.  
(See page EF & EC-148.)]
        E --> F[Reinstall any part removed.]
        F --> End([INSPECTION END])
    
```

FUEL PUMP RELAY (Not self-diagnostic item)

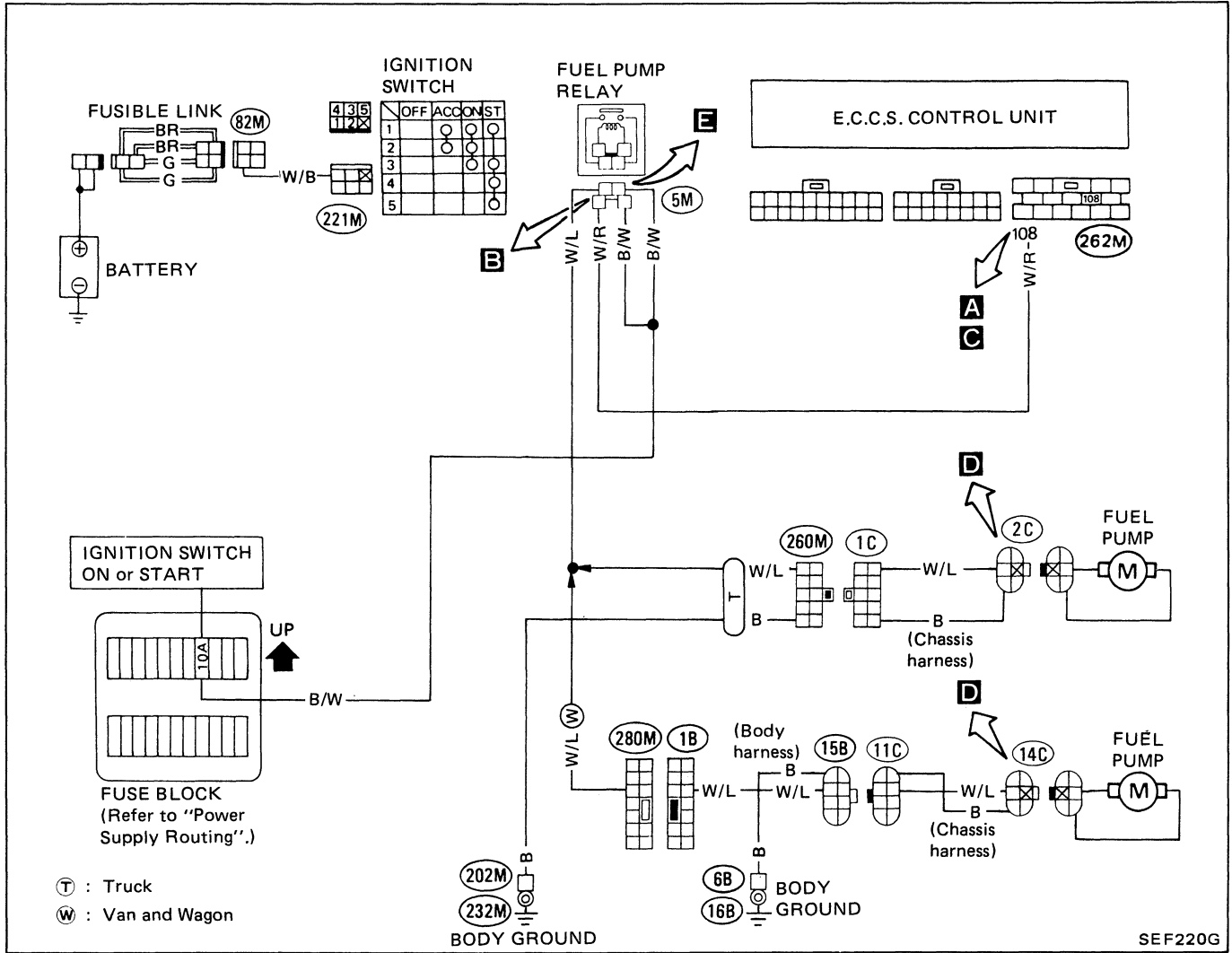

Fuel pump relay location

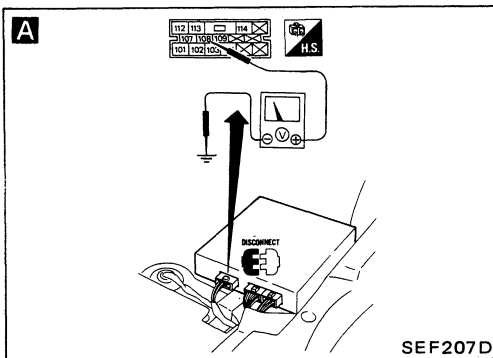
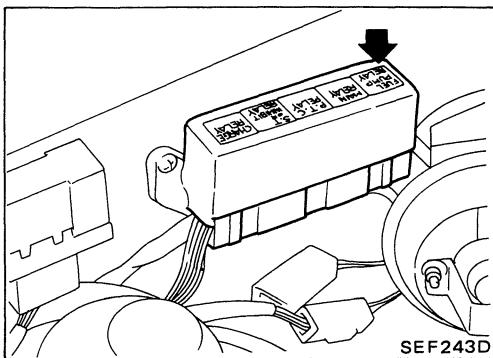

FUEL PUMP RELAY (Not self-diagnostic item)

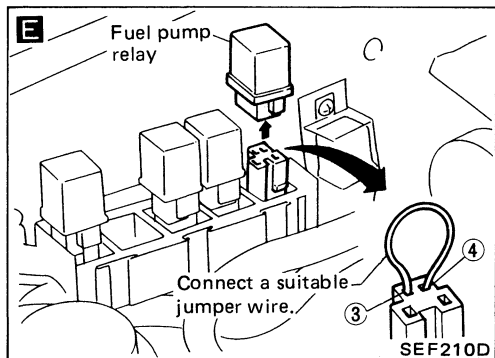
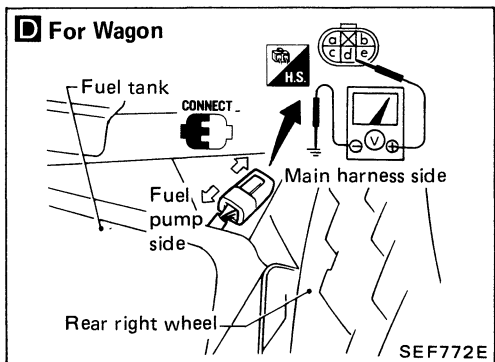
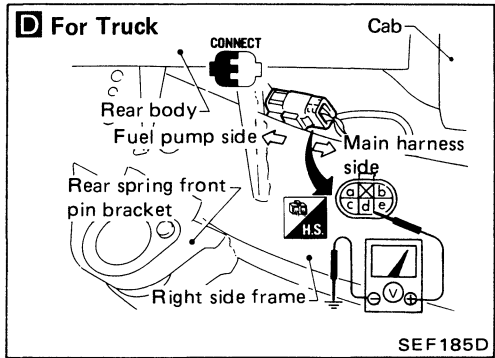
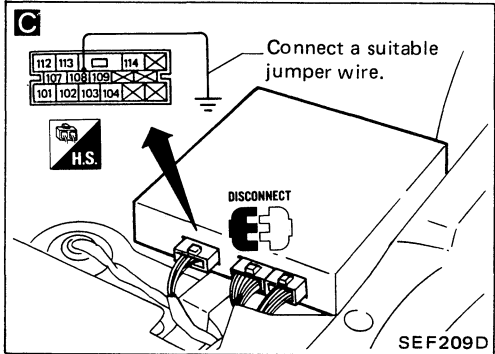
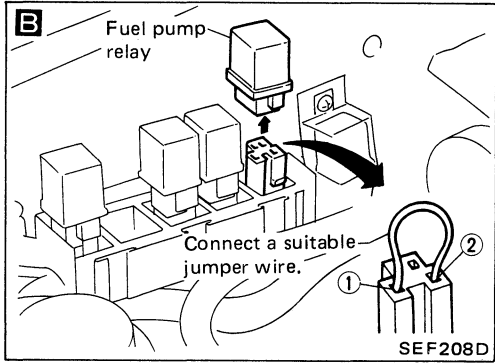

1) Turn ignition switch "OFF".
 2) Disconnect 15-pin connector from E.C.U.
 3) Turn ignition switch "ON".
A 4) Check voltage between terminal 108 and ground. **Battery voltage should exist.**

N.G.
 1) Turn ignition switch "OFF".
 2) Remove fuel pump relay.
B 3) Connect terminals 1 and 2 with a suitable jumper wire.
 4) Turn ignition switch "ON".
A 5) Recheck voltage between terminal 108 and ground. **Battery voltage should exist.**

O.K.
 1) Turn ignition switch "OFF".
C 2) Connect terminal 108 to ground using a suitable jumper wire.
 3) Turn ignition switch "ON".
D 4) Check voltage between terminal d at fuel pump harness connector and ground. **Battery voltage should exist for 5 seconds.**

O.K. → Replace fuel pump relay.
 N.G. → Check harness continuity between fuel pump relay and battery.

O.K.
 Reinstall any part removed.

N.G.
 1) Turn ignition switch "OFF".
 2) Remove fuel pump relay.
E 3) Connect terminals 3 and 4 using a suitable jumper wire.
 4) Turn ignition switch "ON".
D 5) Recheck voltage between terminal d at fuel pump harness connector and ground. **Battery voltage should exist.**

INSPECTION END

POWER SOURCE FOR E.C.U. & GROUND CIRCUIT FOR E.C.U. (Not self-diagnostic item)

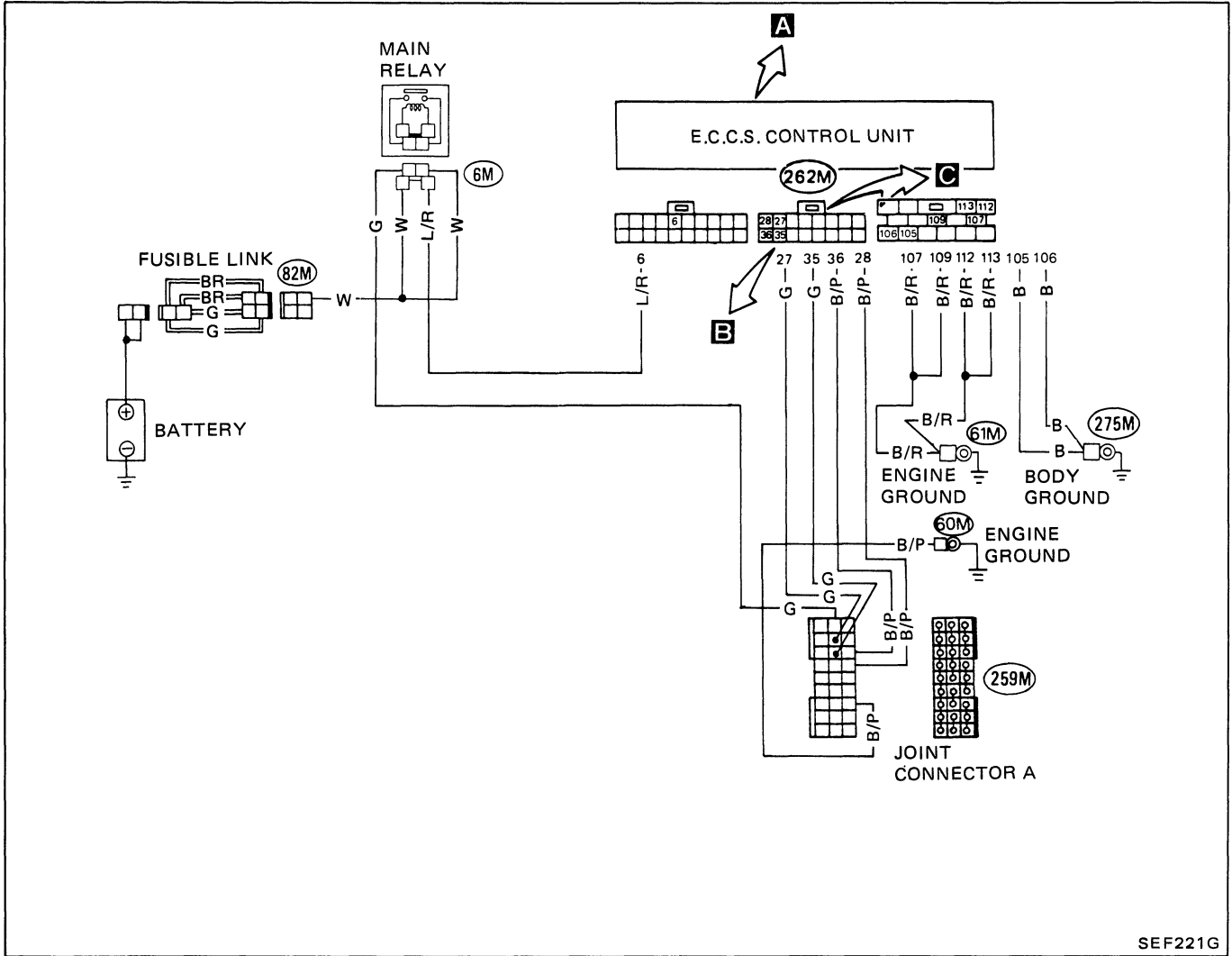

SEF221G

POWER SOURCE FOR E.C.U. & GROUND CIRCUIT FOR E.C.U. (Not self-diagnostic item)

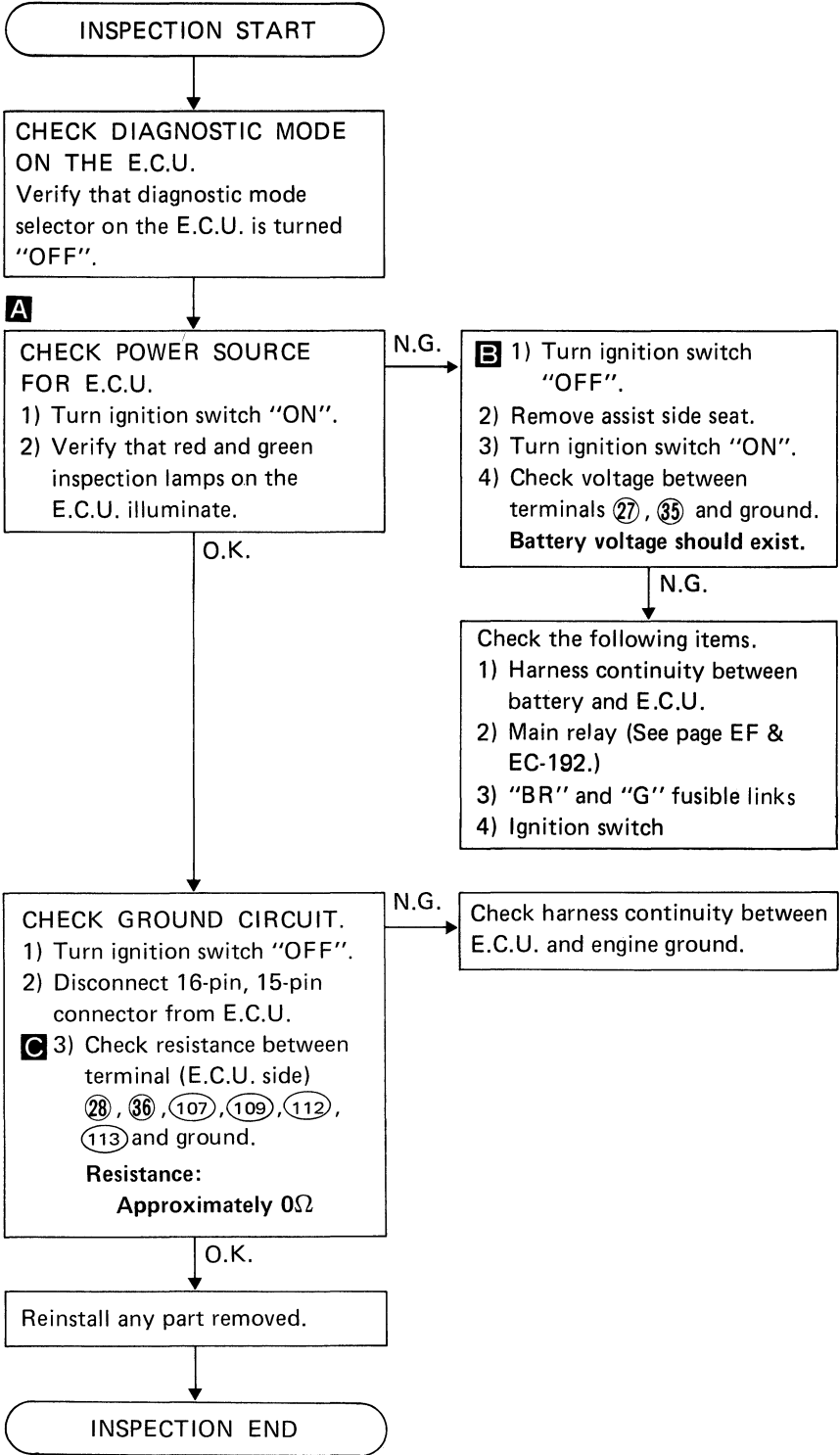
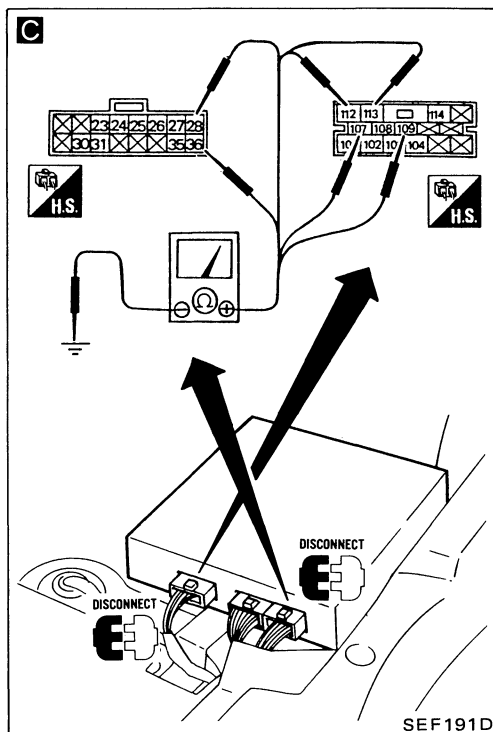
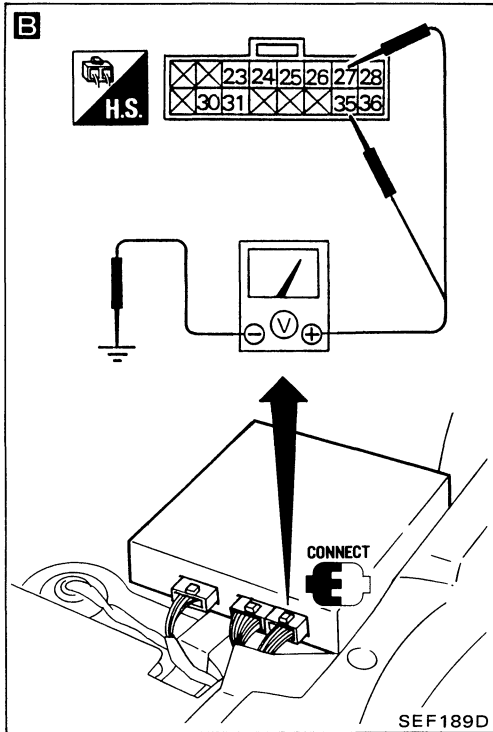
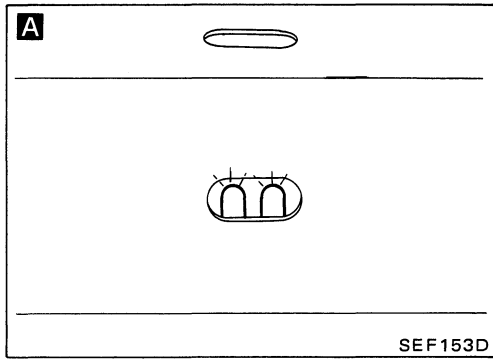

MAIN RELAY (Not self-diagnostic item)

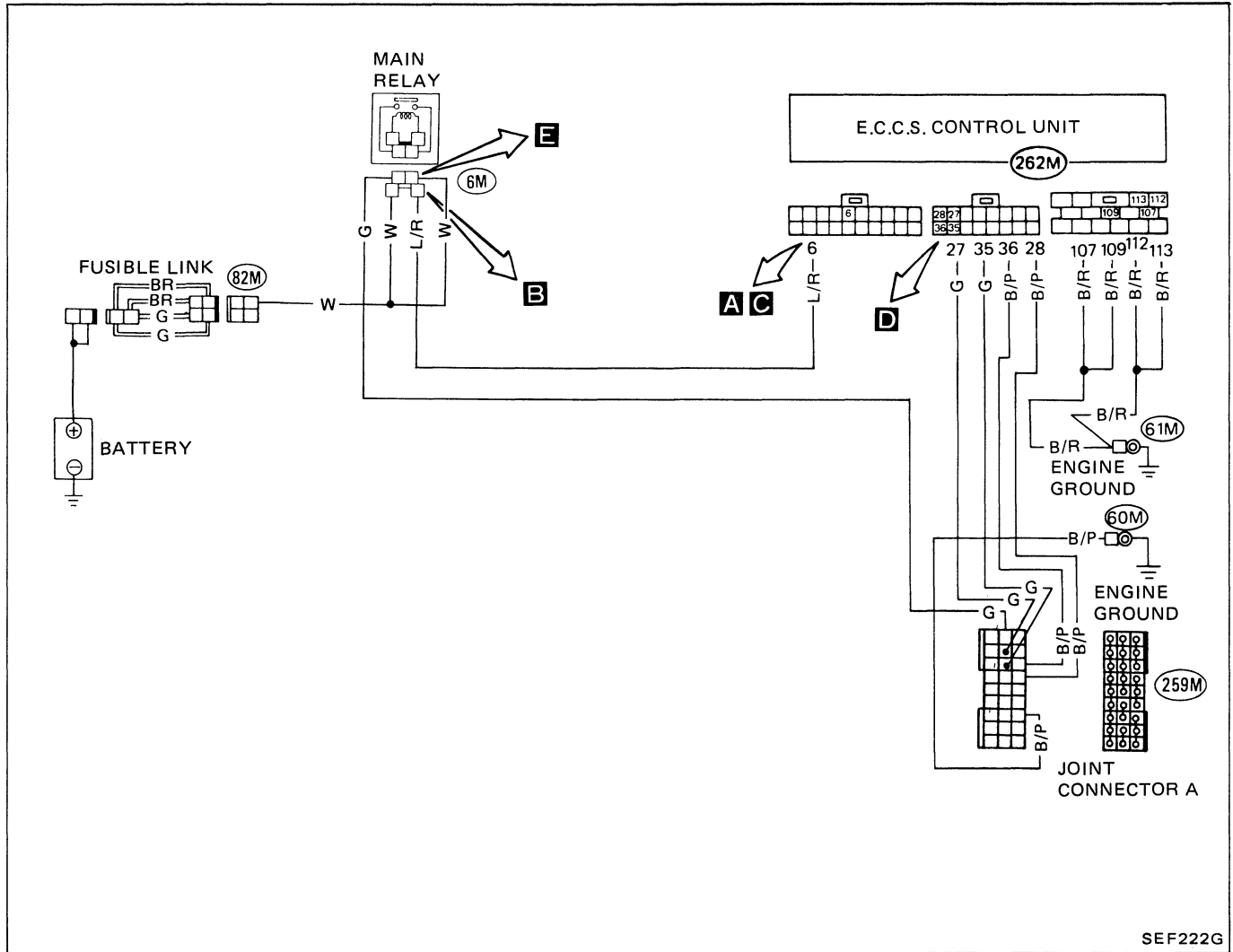

SEF222G

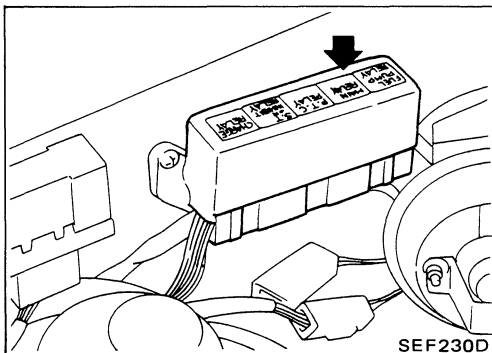

Main relay location

SEF230D

MAIN RELAY (Not self-diagnostic item)

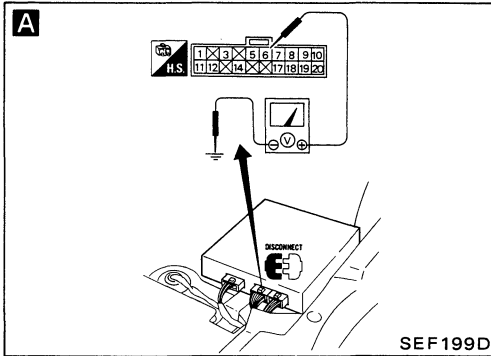

- 1) Turn ignition switch "OFF".
- 2) Disconnect 20-pin connector from E.C.U.
- 3) Turn ignition switch "ON" again.
- A** 4) Check voltage between terminal ⑥ and ground.
Battery voltage should exist.

- N.G.
- 1) Turn ignition switch "OFF".
 - 2) Remove main relay.
 - B** 3) Connect terminals ① and ② using a suitable jumper wire.
 - 4) Turn ignition switch "ON".
 - A** 5) Recheck voltage between terminal ⑥ and ground.
Battery voltage should exist.

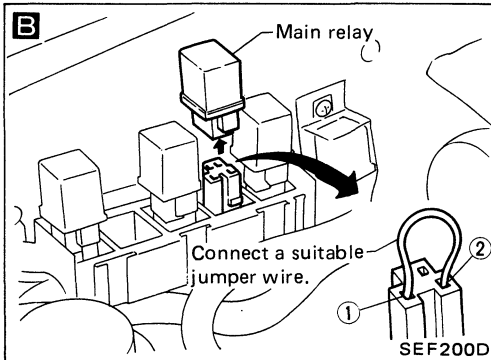

- O.K.
- 1) Turn ignition switch "OFF".
 - C** 2) Connect terminal ⑥ to ground using a suitable jumper wire.
 - 3) Turn ignition switch "ON".
 - D** 4) Check voltage between terminals ⑳, ⑳ and ground.
Battery voltage should exist.

- O.K.
- N.G.
- Replace main relay.

Check harness continuity between main relay and battery.

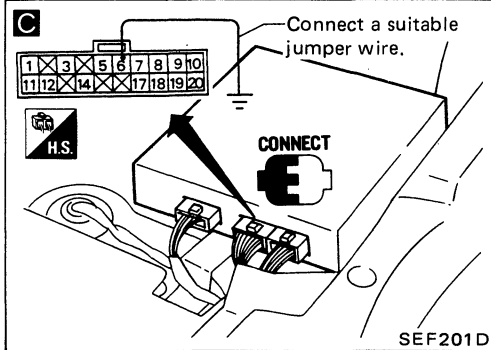

- N.G.
- 1) Turn ignition switch "OFF".
 - 2) Remove main relay.
 - E** 3) Connect terminals ③ and ④ using a suitable jumper wire.
 - 4) Turn ignition switch "ON".
 - D** 5) Recheck voltage between terminals ⑳, ⑳ and ground.
Battery voltage should exist.

- O.K.
- N.G.

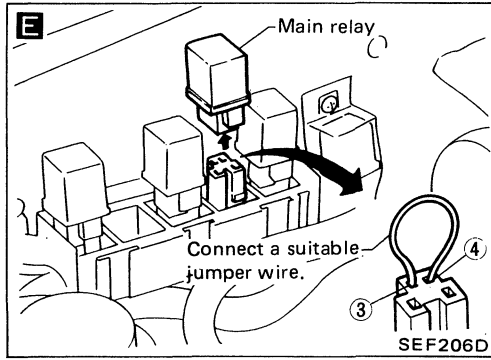
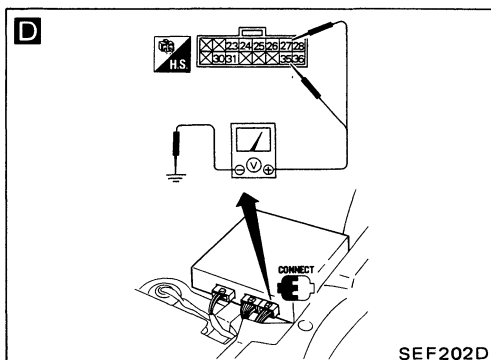

A.I.V. CONTROL (Not self-diagnostic item); 2WD MODEL ONLY

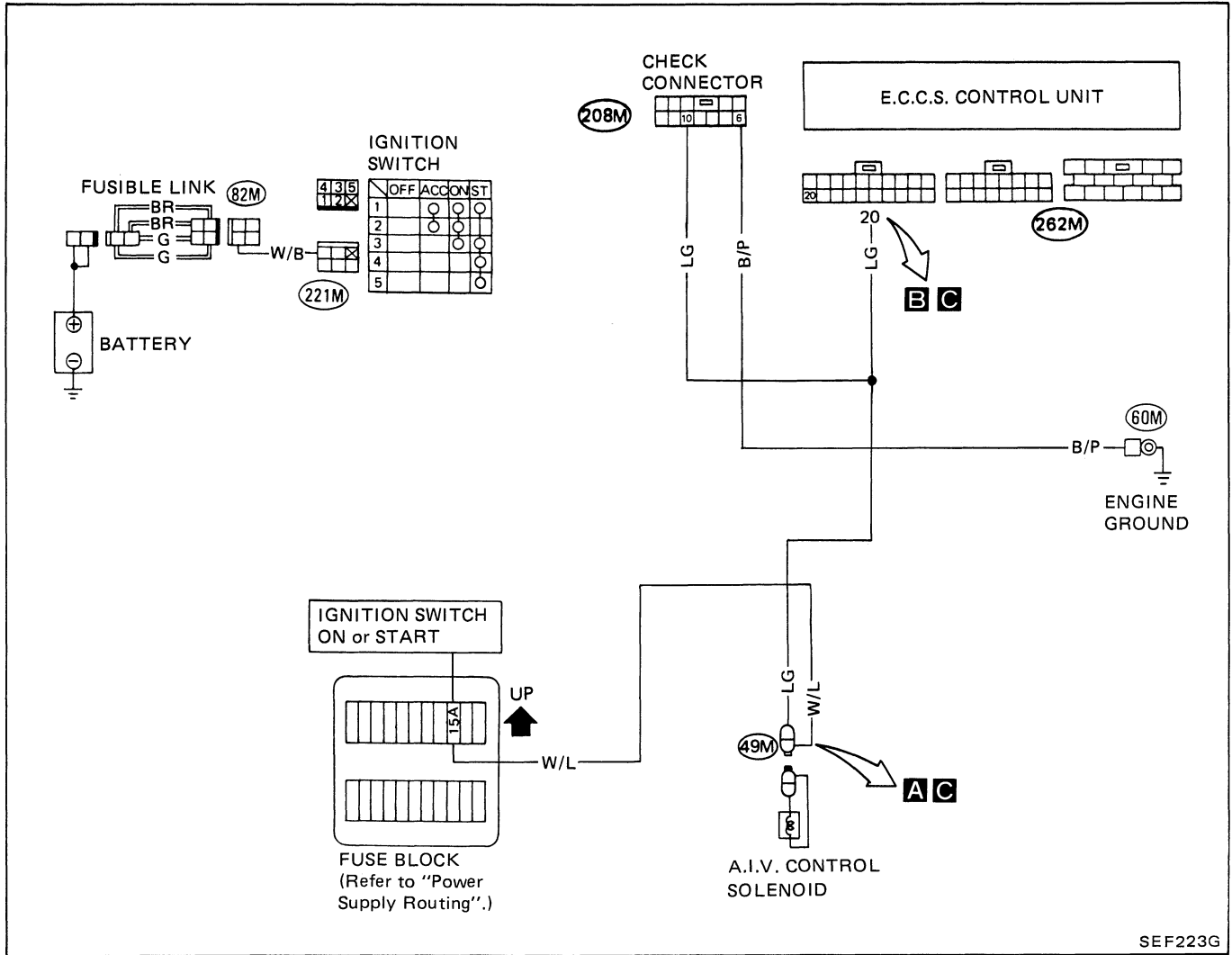

SEF223G

A.I.V. CONTROL (Not self-diagnostic item); 2WD MODEL ONLY

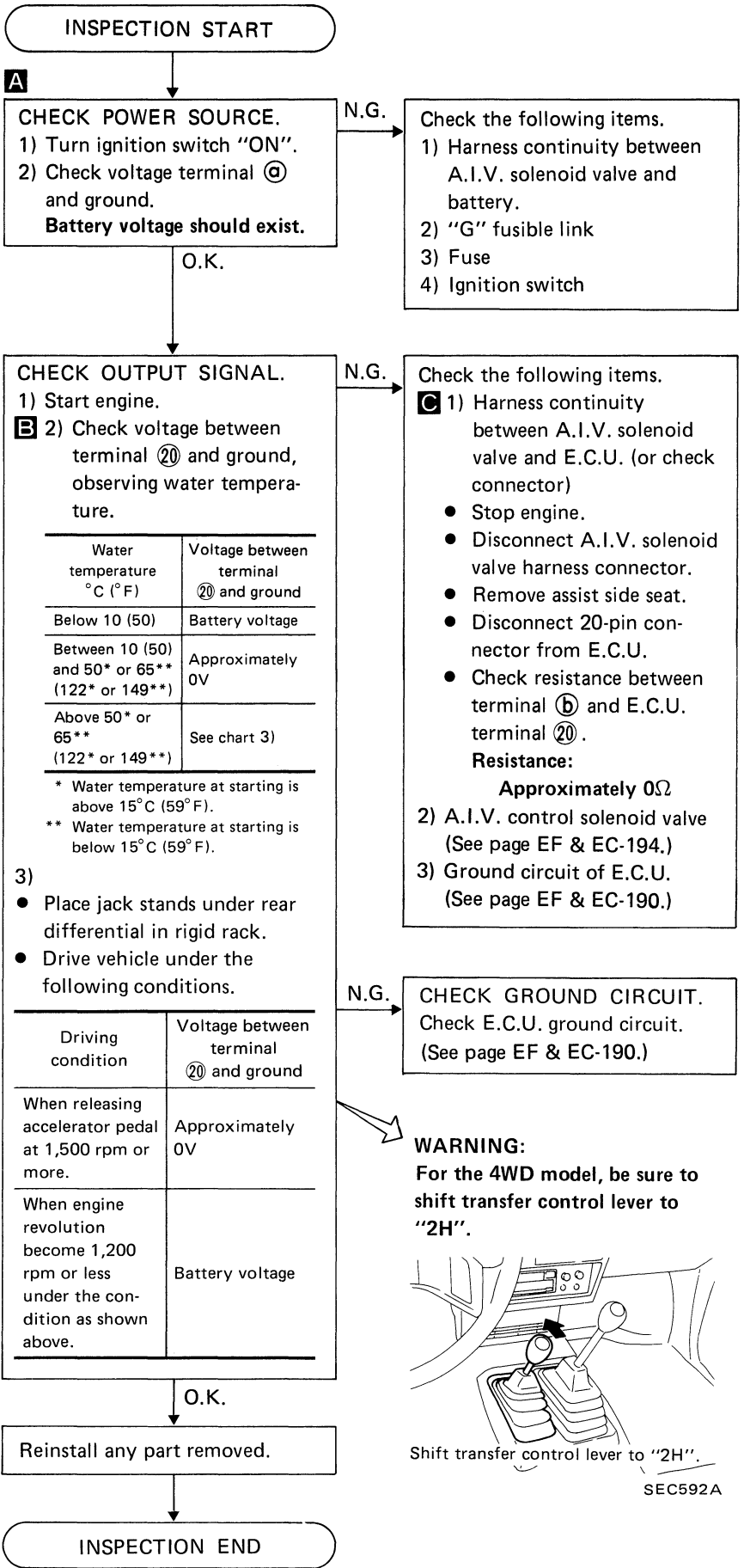
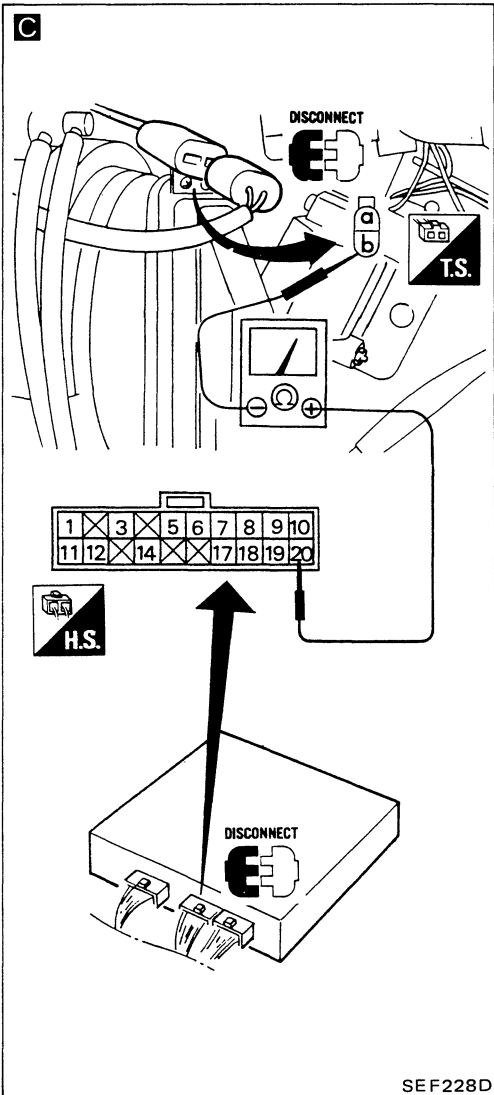
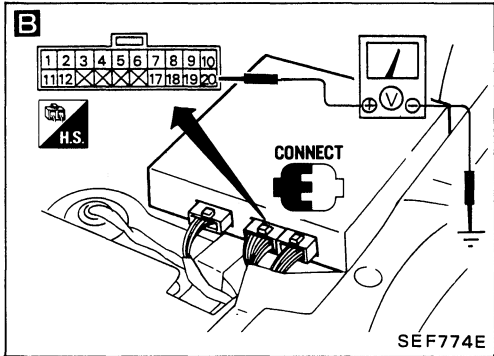
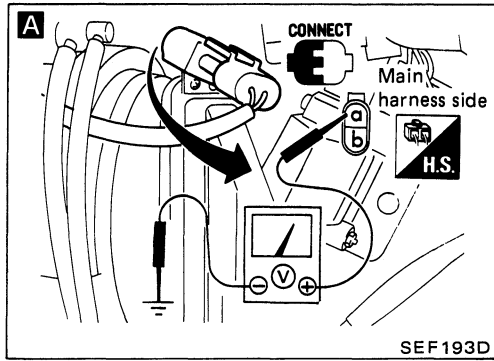

IDLE-UP CONTROL (Not self-diagnostic item)

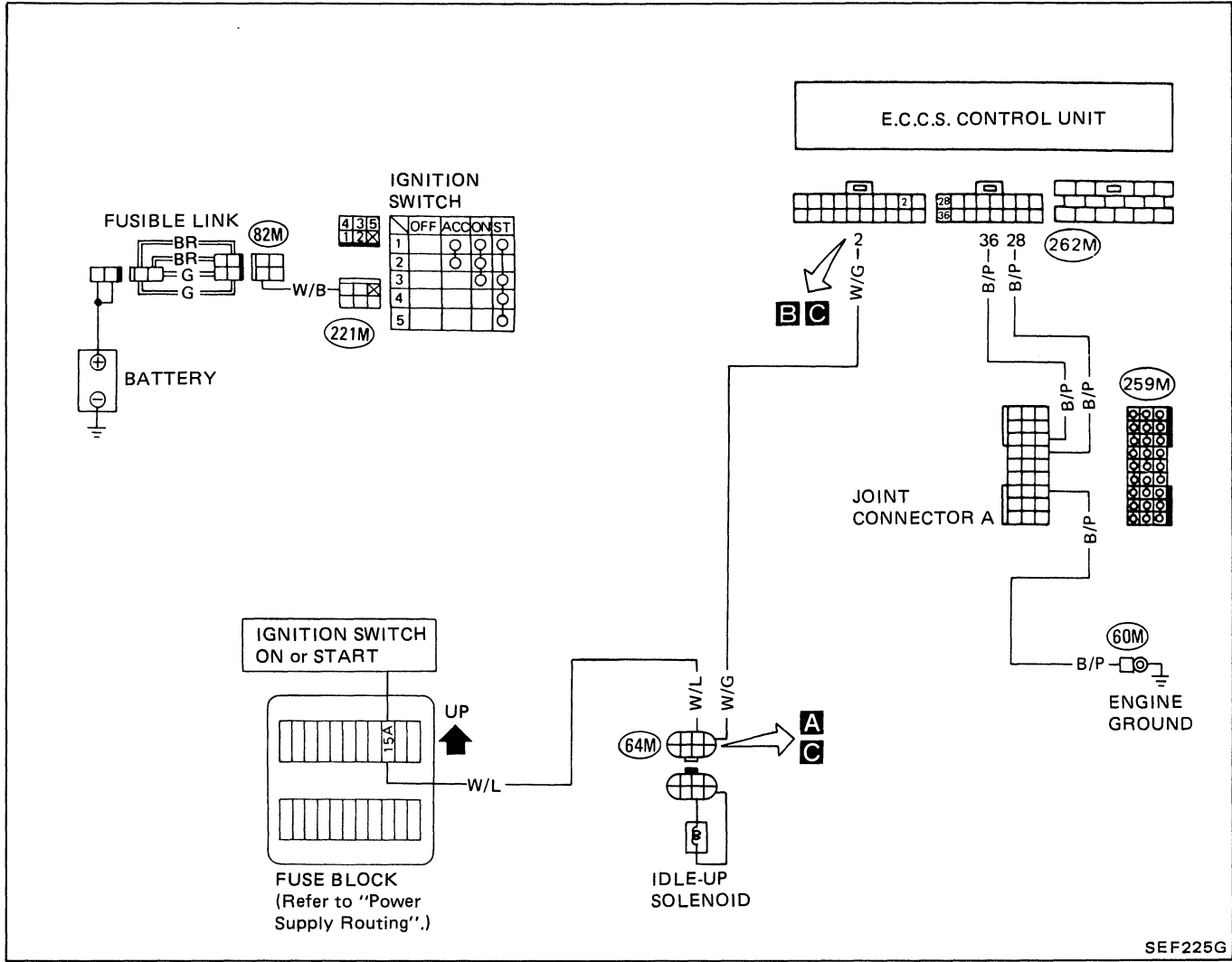

IDLE-UP CONTROL (Not self-diagnostic item)

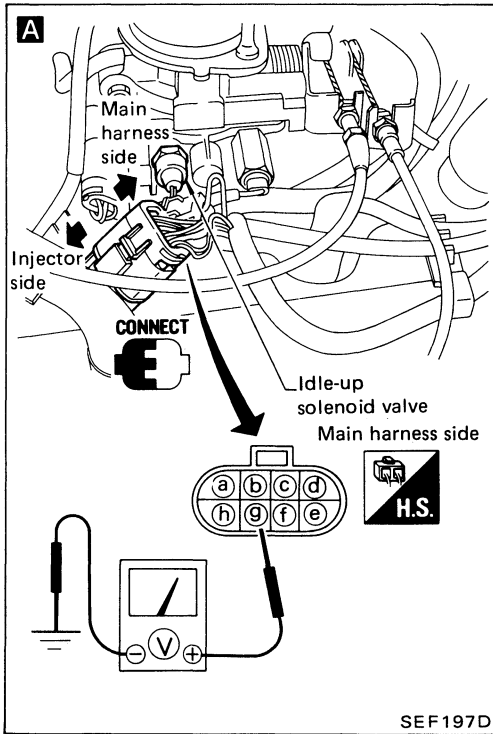

SEF197D

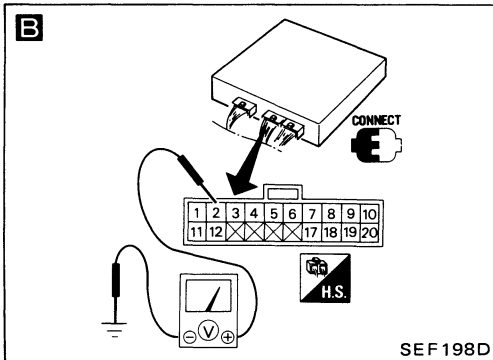

SEF198D

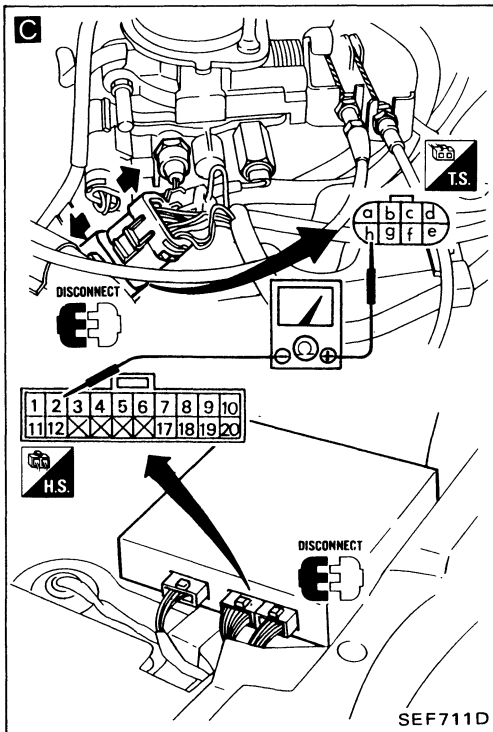

SEF711D

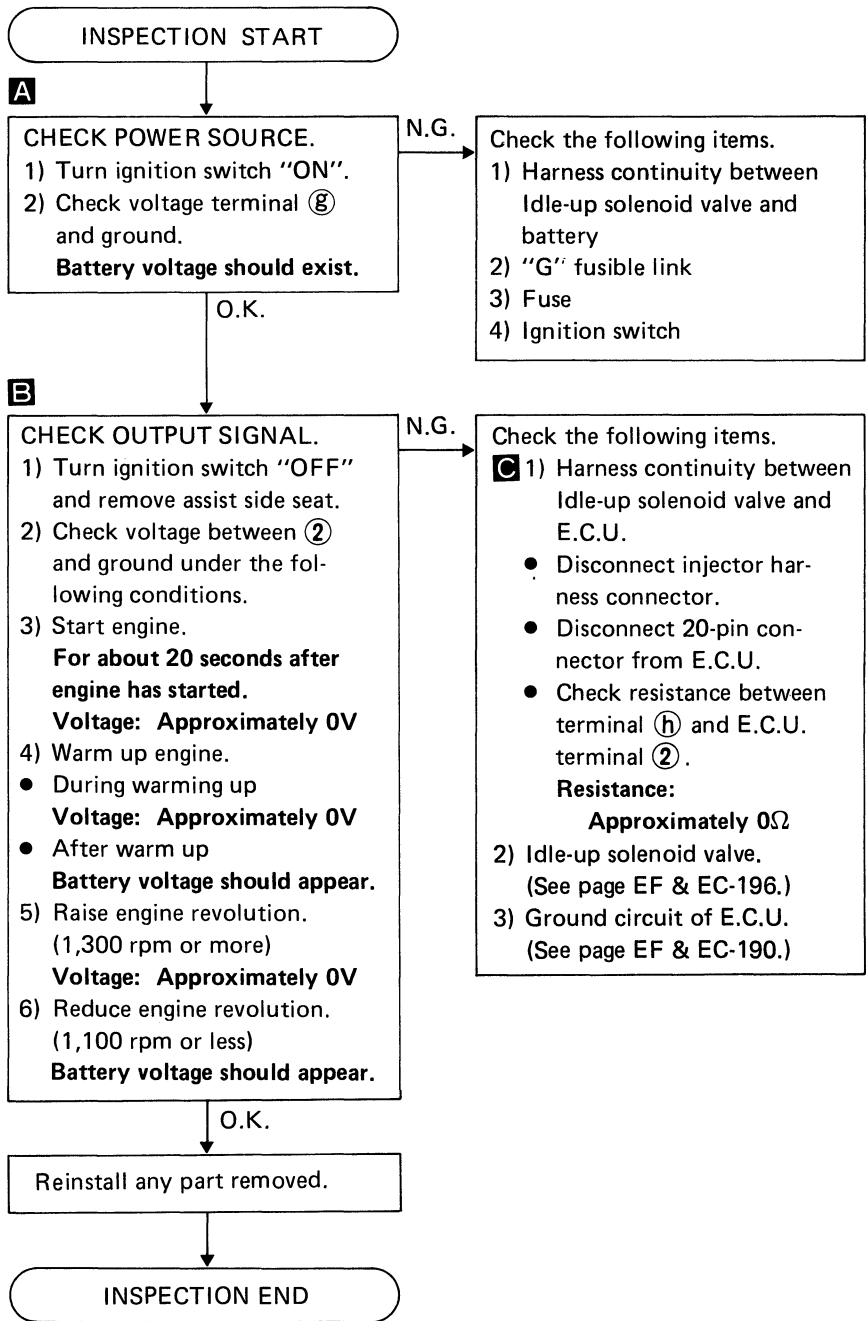

SPARK PLUG SWITCHING CONTROL (Not self-diagnostic item)

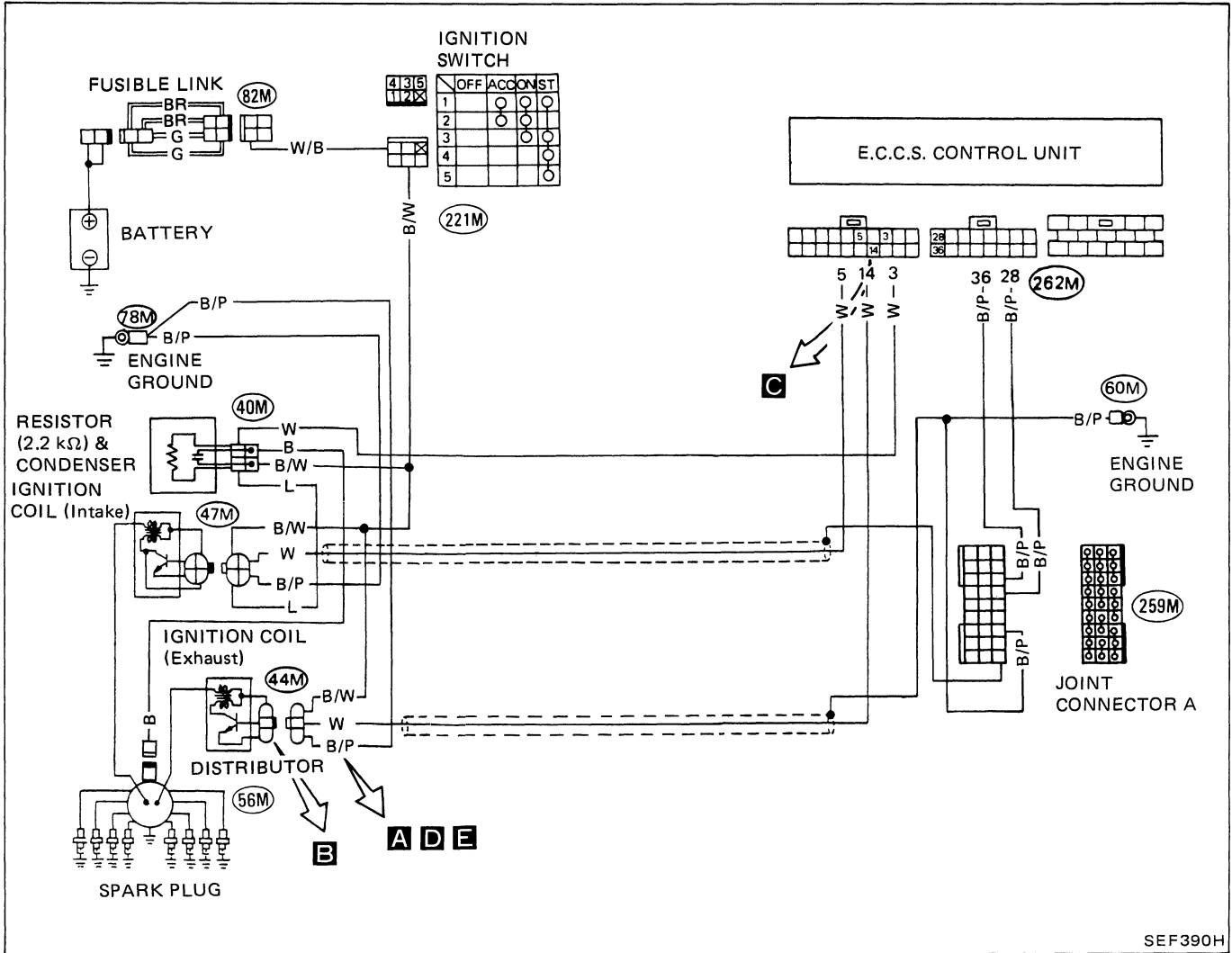

SEF390H

INSPECTION START

A
 CHECK POWER SOURCE.
 1) Turn ignition switch "ON".
 2) Check voltage between terminal ① and ground.
Battery voltage should exist.

N.G. → Check the following items.
 1) Harness continuity between battery and power transistor (exhaust side.)
 2) "G" fusible link
 3) Ignition switch

O.K. ↓

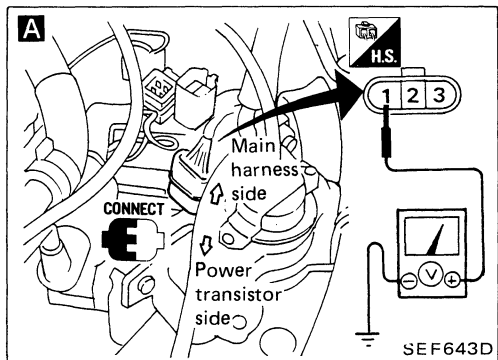

SPARK PLUG SWITCHING CONTROL (Not self-diagnostic item)

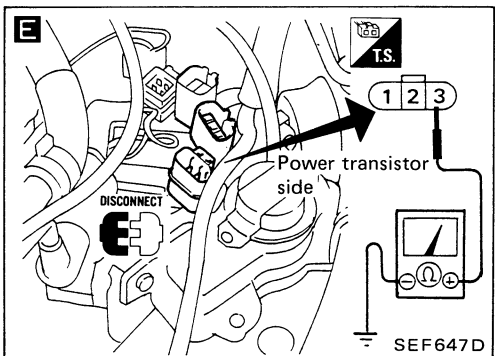
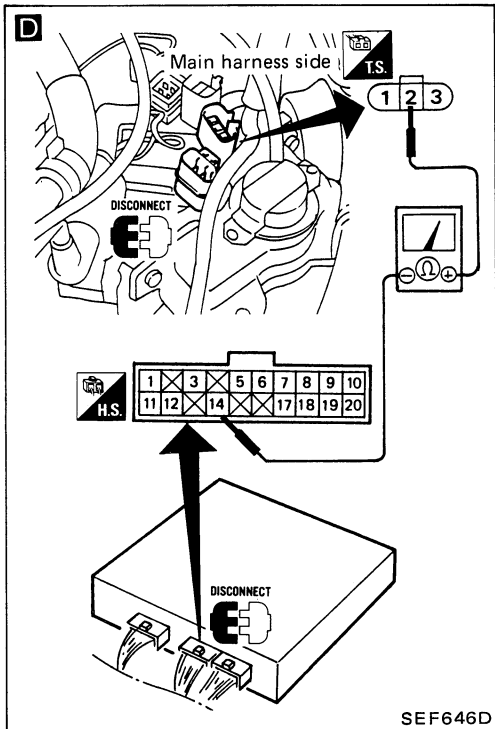
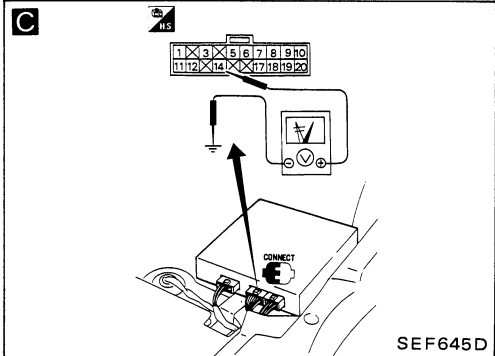
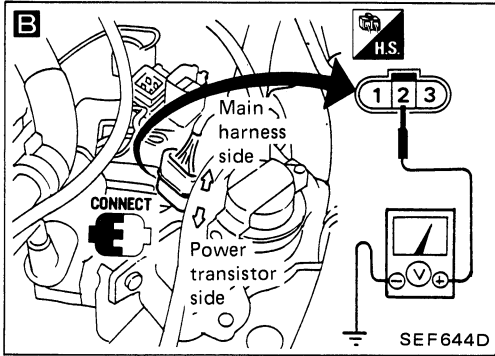

⊕

CHECK OUTPUT SIGNAL.

1) Start engine, and warm it up sufficiently.

B 2) Check voltage between terminal ② and ground when depressing accelerator pedal fully and suddenly.

Output voltage drops to approximately 0V.

O.K.

CHECK GROUND CIRCUIT.

1) Stop engine.

2) Disconnect power transistor harness connector.

E 3) Check resistance between terminal ③ and ground.

Resistance: Approximately 0Ω

O.K.

CHECK COMPONENT.

1) Check power transistor. (See page EF & EC-155.)

O.K.

INSPECTION END

Check the following items.

C 1) E.C.U.

- Stop engine, and remove assist side seat.
- Start engine and make sure that engine is sufficiently warmed up.
- Check voltage between terminal ⑭ and ground when depressing accelerator pedal fully and suddenly.

Output voltage drops to approximately 0V.

D 2) Harness continuity between E.C.U. and power transistor (exhaust side)

- Stop engine.
- Disconnect power transistor harness connector (exhaust side).
- Disconnect 20-pin connector from E.C.U.
- Check resistance between terminal ② and E.C.U. terminal ⑭.

Resistance: Approximately 0Ω

Check the following items.

1) Harness continuity between power transistor and ground

2) Engine ground

3) Power transistor ground

Replace power transistor.

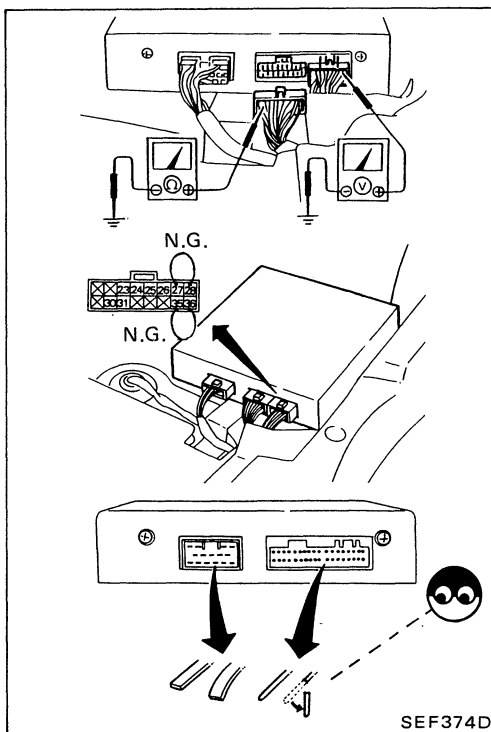
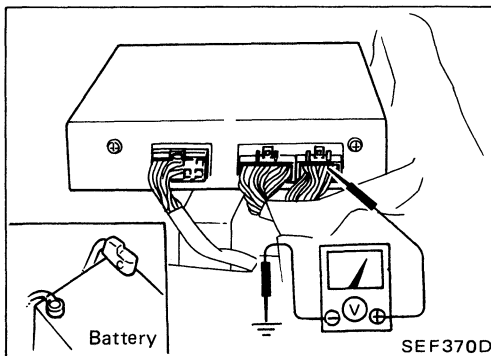
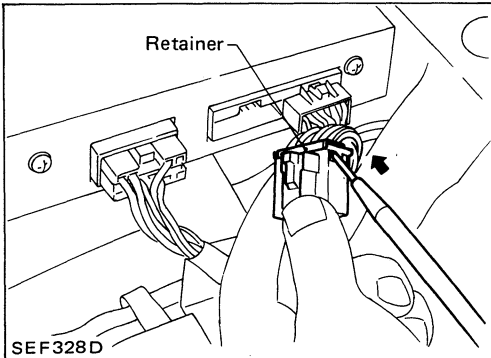
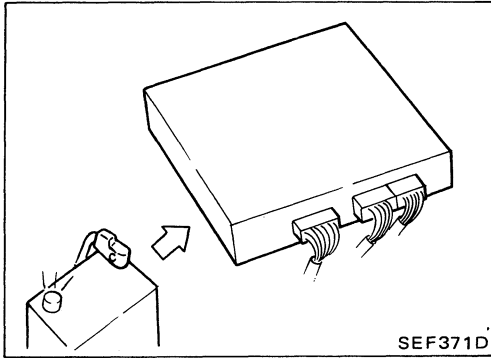

MEASUREMENT VOLTAGE OR RESISTANCE OF E.C.U.

1. Disconnect battery ground cable.
2. Remove assist side or bench seat from vehicle.
3. Disconnect 20- and 16-pin connector from E.C.U.
4. Remove pin terminal retainer from 20- and 16-pin connector to make it easier to insert tester probes.
5. Connect 20- and 16-pin connector to E.C.U. carefully.
6. Connect battery ground cable.
7. Measure the voltage at each terminal by following "E.C.U. inspection table".

CAUTION:

- a. Perform all voltage measurements with the connectors connected.
- b. Perform all resistance measurements with the connectors disconnected.
- c. Make sure that there is not any bends or breaks on E.C.U. pin terminal before measurements.
- d. Do not touch tester probes between terminals ②⑦ and ②⑧, ③⑤ and ③⑥.

E.C.U. inspection table

*Data are reference values.

TERMI- NAL NO.	ITEM	CONDITION	*DATA	ENGINE	
				VG30i	Z24i
2	Idle-up solenoid	<div style="border: 1px solid black; padding: 2px; display: inline-block;">Engine is running.</div> <ul style="list-style-type: none"> └ For about 20 seconds after starting engine. └ Steering wheel is turned. └ Blower switch is "ON". └ Headlamps are in high beam position. 	Approximately 1.0V	○	○
		<div style="border: 1px solid black; padding: 2px; display: inline-block;">Engine is running.</div> <ul style="list-style-type: none"> └ Except the conditions shown above 	BATTERY VOLTAGE (11 - 14V)		
3	Ignition check	<div style="border: 1px solid black; padding: 2px; display: inline-block;">Engine is running.</div> <ul style="list-style-type: none"> └ Idle speed 	9 - 12V (Decreases as engine revs up.)	○	○
4	E.G.R. cut solenoid	<div style="border: 1px solid black; padding: 2px; display: inline-block;">Engine is running.</div> <ul style="list-style-type: none"> └ High engine revolution └ Idle speed 	0.8 - 1.0V	○	○
		<div style="border: 1px solid black; padding: 2px; display: inline-block;">Engine is running.</div> <ul style="list-style-type: none"> └ Except the above 	BATTERY VOLTAGE (11 - 14V)		
5	Ignition signal	<div style="border: 1px solid black; padding: 2px; display: inline-block;">Engine is running.</div> <ul style="list-style-type: none"> └ Idle speed 	0.4 - 0.6V	○	
			0.2 - 0.4V		○ (Intake)
		<div style="border: 1px solid black; padding: 2px; display: inline-block;">Engine is running.</div> <ul style="list-style-type: none"> └ Engine speed is 2,000 rpm. 	Approximately 1.0V	○	
			Approximately 0.8V		○ (Intake)
6	Main relay	<div style="border: 1px solid black; padding: 2px; display: inline-block;">Engine is running.</div> <p style="text-align: center;">↓</p> <div style="border: 1px solid black; padding: 2px; display: inline-block;">Ignition switch "OFF"</div> <ul style="list-style-type: none"> └ For 15 seconds after turning off ignition switch. 	0.8 - 1.0V	○	○
		<div style="border: 1px solid black; padding: 2px; display: inline-block;">Ignition switch "OFF"</div> <ul style="list-style-type: none"> └ In 15 seconds after turning off ignition switch. 	BATTERY VOLTAGE (11 - 14V)		

E.C.U. INPUT/OUTPUT SIGNAL INSPECTION

VG30i Z24i

*Data are reference values.

TERMI- NAL NO.	ITEM	CONDITION	*DATA	ENGINE	
				VG30i	Z24i
8	Crank angle sensor (Position signal)	<div style="border: 1px solid black; padding: 2px; display: inline-block;">Engine is running.</div> Do not run engine at high speed under no load.	2.5 - 2.7V	○	○
9	Start signal	<div style="border: 1px solid black; padding: 2px; display: inline-block;">Cranking</div>	8 - 12V	○	○
10	Neutral/clutch switch or Inhibitor switch	<div style="border: 1px solid black; padding: 2px; display: inline-block;">Ignition switch "ON"</div> └ Neutral/Parking	0V	○	○
		<div style="border: 1px solid black; padding: 2px; display: inline-block;">Ignition switch "ON"</div> └ Except the above gear position	Approximately 5V (0V: with clutch disengaged)		
12	Mixture heater relay	<div style="border: 1px solid black; padding: 2px; display: inline-block;">Engine is running.</div> └ Engine is cold or during warm up. [Water temperature is below 70°C (158°F).]	0.7 - 0.9V	○	○
		<div style="border: 1px solid black; padding: 2px; display: inline-block;">Engine is running.</div> └ After warming up. [Water temperature is above 70°C (158°F).]	BATTERY VOLTAGE (11 - 14V)		
14	Ignition signal	<div style="border: 1px solid black; padding: 2px; display: inline-block;">Engine is running.</div> └ Idle speed	0.2 - 0.4V	○	○ (Exhaust)
		<div style="border: 1px solid black; padding: 2px; display: inline-block;">Engine is running.</div> └ Engine speed is 2,000 rpm	Approximately 0.8V		
17	Crank angle sensor (Reference signal)	<div style="border: 1px solid black; padding: 2px; display: inline-block;">Engine is running.</div> Do not run engine at high speed under no load.	0.2 - 0.4V	○	○
18	Idle switch (⊖ side)	<div style="border: 1px solid black; padding: 2px; display: inline-block;">Ignition switch "ON"</div> └ Throttle valve: idle position Inspection should be done after warming up engine sufficiently.	Approximately 8 - 10V	○	○
		<div style="border: 1px solid black; padding: 2px; display: inline-block;">Ignition switch "ON"</div> └ Throttle valve: except idle position	Approximately 0V		

*Data are reference values.

TERMI- NAL NO.	ITEM	CONDITION	*DATA	ENGINE	
				VG30i	Z24i
19	Throttle sensor	Ignition switch "ON" Inspection should be done after warming up engine sufficiently.	0.4 - 4.0V Output voltage varies with the throttle valve opening angle.	○	○
20	A.I.V. cut solenoid	Engine is running. └ Engine is cold. └ [Water temperature is below 15°C (59°F).]	0.8 - 0.9V	○	○ (Only 2WD)
		Engine is running. └ During warming up └ [Water temperature is between 15°C (59°F) and 40°C (104°F).]	BATTERY VOLTAGE (11 - 14V)		
		Engine is running. └ After warming up. └ [Water temperature is above 40°C (104°F).] Idle condition after 3,000 rpm no load driving for 10 seconds When depressing accelerator pedal at the above condition.	0.8 - 0.9V BATTERY VOLTAGE (11 - 14V)		
22	Load signal	Engine is running. └ Steering wheel is turned. └ Blower switch is "ON". └ Headlamps are in high beam.	BATTERY VOLTAGE (11 - 14V)	○	
		Engine is running. └ Except the conditions shown above	Approximately 0V		
23	Water or cylinder head temperature sensor	Engine is running.	1.0 - 5.0V Output voltage varies with engine water temperature.	○	○
24	Exhaust gas sensor	Engine is running. └ After warming up suf- ficiently.	0 - Approximately 1.0V	○	○

E.C.U. INPUT/OUTPUT SIGNAL INSPECTION

VG30i Z24i

*Data are reference values.

TERMI- NAL NO.	ITEM	CONDITION	*DATA	ENGINE	
				VG30i	Z24i
33	Idle switch (⊕ side)	<div style="border: 1px solid black; padding: 2px; display: inline-block;">Engine is running.</div> └ Idle speed	9 - 11V	○	○
		<div style="border: 1px solid black; padding: 2px; display: inline-block;">Engine is running.</div> └ Engine speed is 2,000 rpm.	BATTERY VOLTAGE (11 - 14V)		
27 35	Power source for E.C.U.	<div style="border: 1px solid black; padding: 2px; display: inline-block;">Ignition switch "ON"</div>	BATTERY VOLTAGE (11 - 14V)	○	○
31	Air flow meter	<div style="border: 1px solid black; padding: 2px; display: inline-block;">Engine is running.</div> Do not run engine at high speed under no load.	1.0 - 3.0V Output voltage varies with engine revolution and throttle valve movement.	○	○
101 102 103* 104* 114	Injector (*: VG30i model only)	<div style="border: 1px solid black; padding: 2px; display: inline-block;">Engine is running.</div>	BATTERY VOLTAGE (11 - 14V)	○	○
108	Fuel pump relay	<div style="border: 1px solid black; padding: 2px; display: inline-block;">Ignition switch "ON"</div> └ For 5 seconds after turning ignition switch "ON".	0.7 - 0.9V	○	○
		<div style="border: 1px solid black; padding: 2px; display: inline-block;">Engine is running.</div>	BATTERY VOLTAGE (11 - 14V)		
111	Exhaust gas temperature sensor	<div style="border: 1px solid black; padding: 2px; display: inline-block;">Engine is running.</div> └ Idle speed	1.0V or more	○ ○ (Only California model)	
		<div style="border: 1px solid black; padding: 2px; display: inline-block;">Engine is running.</div> └ E.G.R. system is operating.	0 - 1.0V		

PIN CONNECTOR TERMINAL LAYOUT

20-pin connector

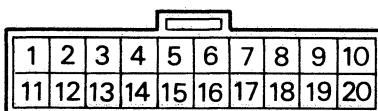

16-pin connector

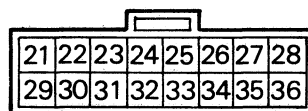

15-pin connector

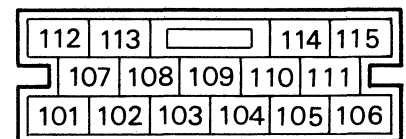

SEF005F

PREPARATION

1. Make sure that the following parts are in good order.

- Battery
- Ignition system
- Engine oil and coolant levels
- Fuses
- E.C.C.S. harness connectors
- Vacuum hoses
- Air intake system (oil filler cap, oil level gauge, etc.)
- Fuel pressure

- A.I.V. hose
 - Engine compression
 - E.G.R. valve operation
 - Throttle valve
2. On air conditioner equipped models, checks should be carried out while the air conditioner is "OFF".
3. When measuring "CO" percentage, insert probe more than 40 cm (15.7 in) into tail pipe.

Overall inspection sequence

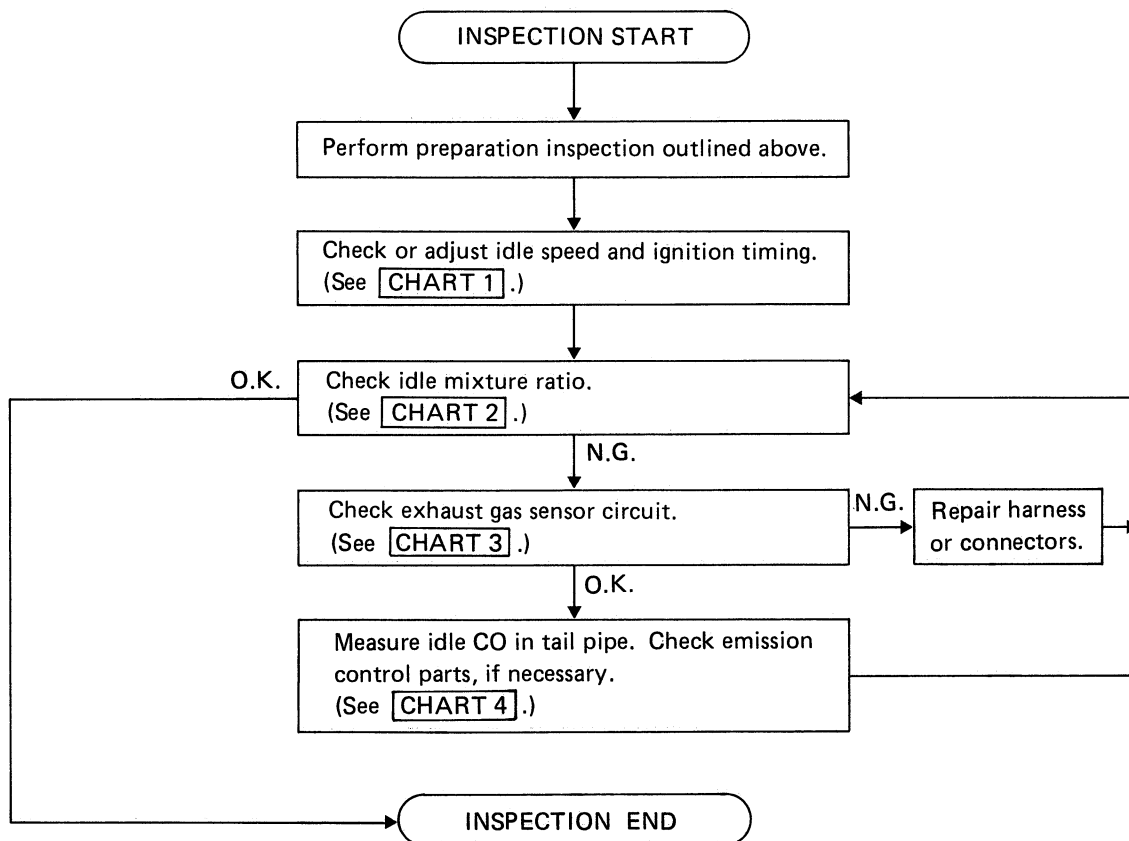
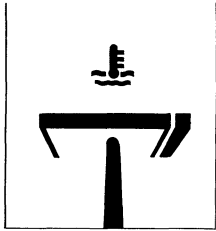
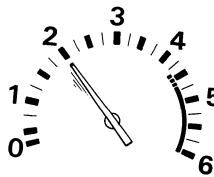

CHART 1

Checking Idle Speed and Ignition Timing



SEF355D



SEF357D

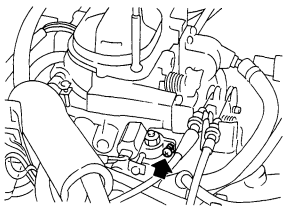

SEF365D

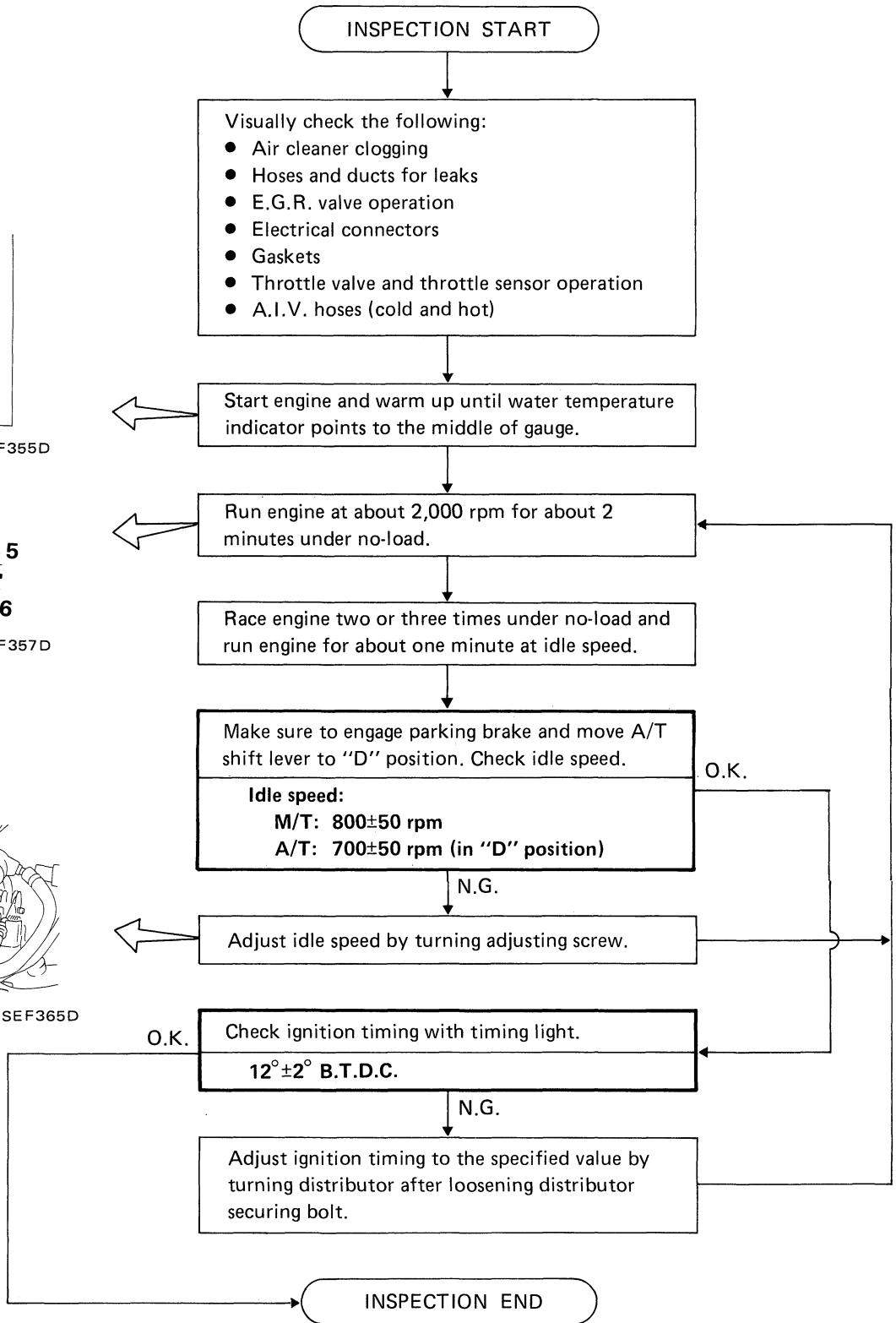
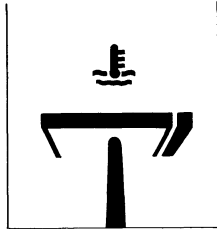
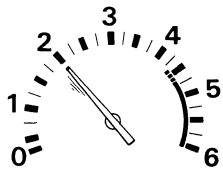

CHART 1

Checking Idle Speed and Ignition Timing



SEF355D



SEF357D

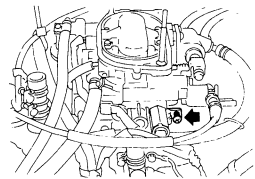

SEF869C

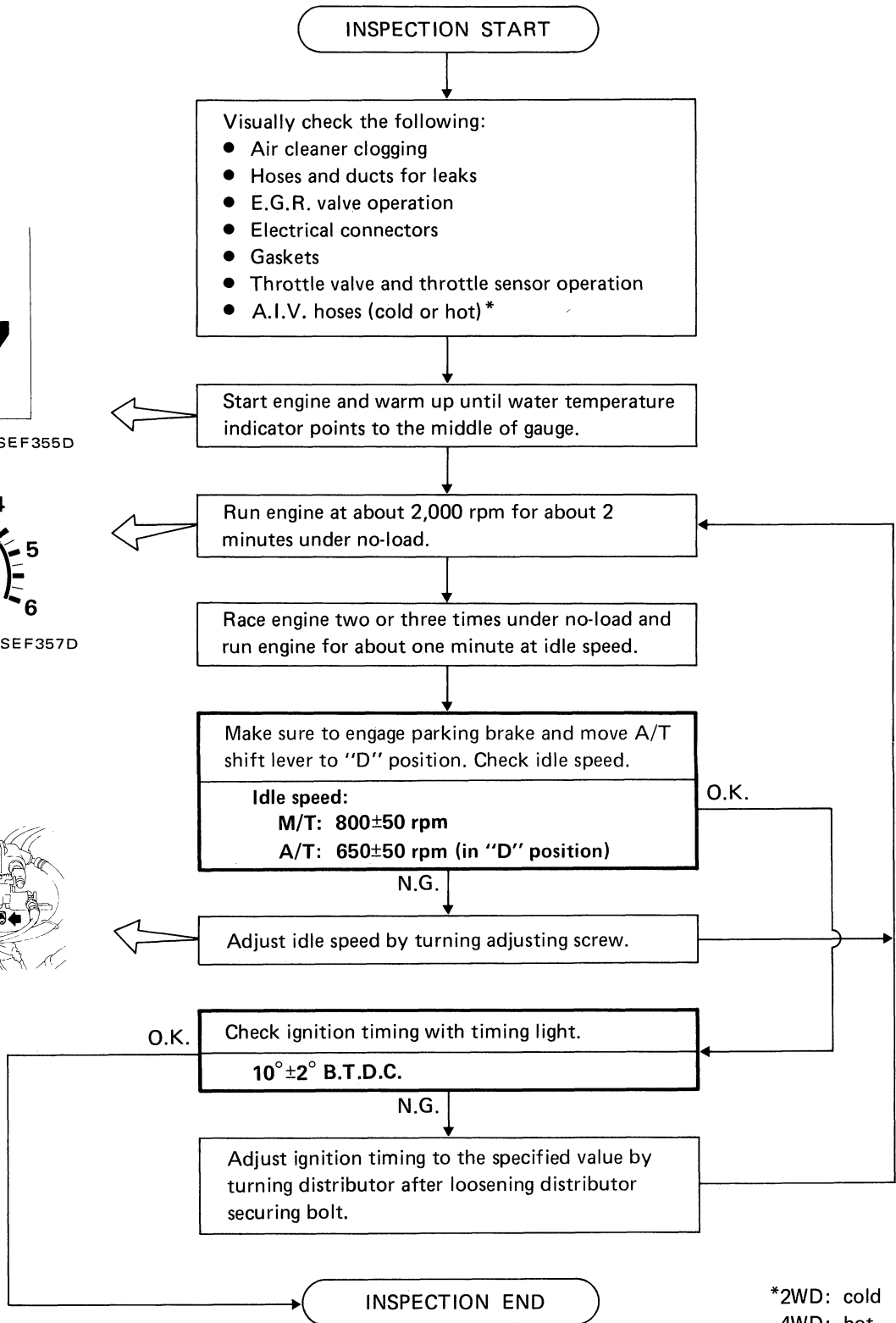

*2WD: cold
4WD: hot

CHART 2

Checking Idle Mixture Ratio

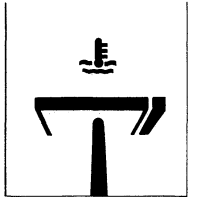

SEF355D

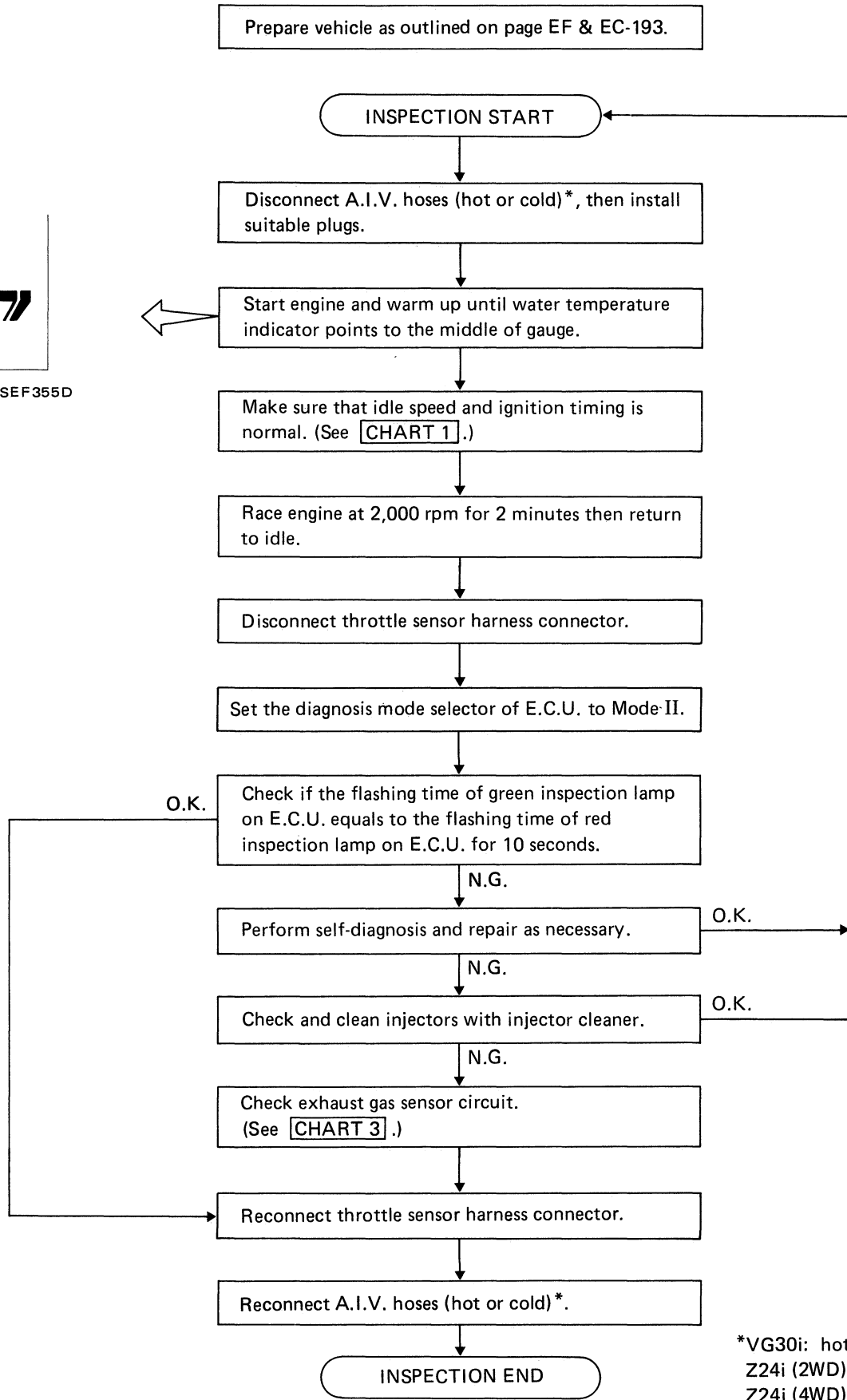

*VG30i: hot & cold
 Z24i (2WD): cold
 Z24i (4WD): hot

CHART 3

Checking Exhaust Gas Sensor Circuit

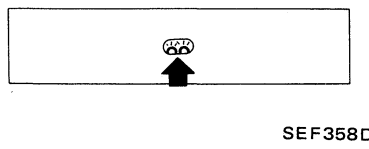
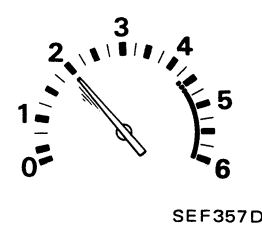
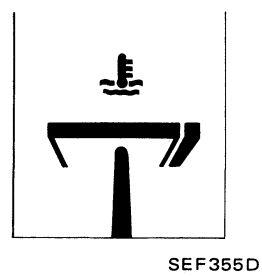
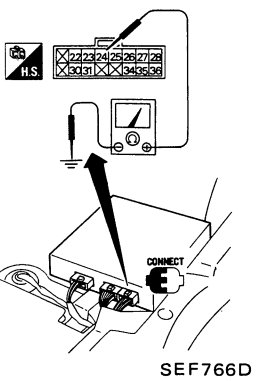
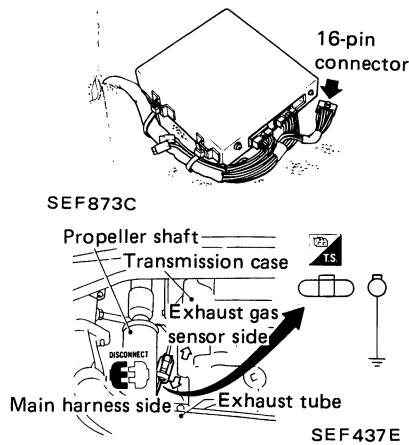

```

    graph TD
      Start([CHECKING START]) --> Step1[Check exhaust gas sensor harness:  
1) Turn off engine and disconnect battery ground cable.  
2) Remove assist side seat.  
3) Disconnect 16-pin connector from E.C.U.  
4) Disconnect exhaust gas sensor harness connector and connect terminal for exhaust gas sensor harness connector to ground with a jumper wire.  
5) Check for continuity between terminal No. 24 of 16-pin connector and body ground.]
      Step1 --> Decision1{Continuity exists ..... O.K.  
Continuity does not exist ..... N.G.}
      Decision1 -- O.K. --> Step2[Connect E.C.C.S. 16-pin connector to E.C.U.  
Connect battery ground cable and disconnect jumper wire from exhaust gas sensor harness, and connect exhaust gas sensor harness connector.]
      Decision1 -- N.G. --> Step1_5[Repair or replace E.C.C.S. harness between E.C.U. and exhaust gas sensor.]
      Step1_5 --> Step2
      Step2 --> Step3[Disconnect hot and cold A.I.V. hoses, then install suitable plugs.]
      Step3 --> Step4[Start engine and warm up until water temperature indicator points to the middle of gauge.]
      Step4 --> Step5[Run engine at about 2,000 rpm for about 2 minutes under no-load.]
      Step5 --> Step6[Race engine two or three times under no-load, then run engine at idle speed.]
      Step6 --> Step7[Check if green lamp goes on and off 5 times or more during 10 seconds at 2,000 rpm.]
      Step7 -- O.K. --> Step8[Measure idle CO in tail pipe. (See CHART 4.)]
      Step7 -- N.G. --> Step9[Repair harness or connectors.]
      Step9 --> Step10[Check idle mixture ratio. (See CHART 2.)]
  
```

CHART 3

Checking Exhaust Gas Sensor Circuit

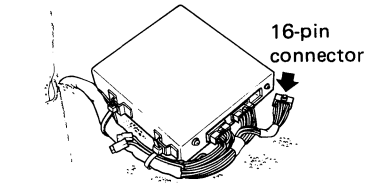

SEF873C

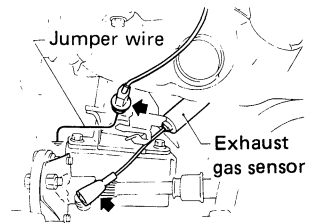

SEF874C

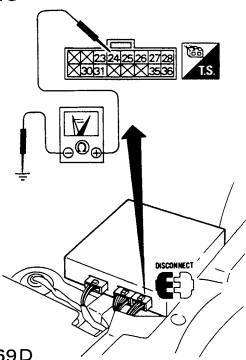

SEF769D

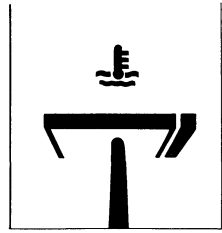

SEF355D

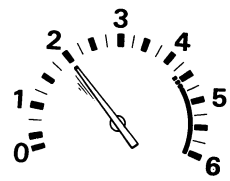

SEF357D

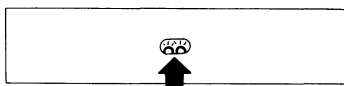

SEF358D

INSPECTION START

Check exhaust gas sensor harness:

- 1) Turn off engine and disconnect battery ground cable.
- 2) Remove assist side seat.
- 3) Disconnect 16-pin connector from E.C.U.
- 4) Disconnect exhaust gas sensor harness connector and connect terminal for exhaust gas sensor harness connector to ground with a jumper wire.
- 5) Check for continuity between terminal No. 24 of 16-pin connector and body ground.

Continuity exists O.K.
Continuity does not exist N.G.

O.K.

N.G.

Repair or replace E.C.C.S. harness between E.C.U. and exhaust gas sensor.

Connect E.C.C.S. 16-pin connector to E.C.U. Connect battery ground cable and disconnect jumper wire from exhaust gas sensor harness, and connect exhaust gas sensor harness connector.

Disconnect A.I.V. hoses (hot or cold)*, then install suitable plugs.

Start engine and warm up until water temperature indicator points to the middle of gauge.

Run engine at about 2,000 rpm for about 2 minutes under no-load.

Race engine two or three times under no-load, then run engine at idle speed.

Check if the green lamp goes on and off 7 times or more during 10 seconds at 2,000 rpm.

O.K.

N.G.

Measure idle CO in tail pipe. (See CHART 4.)

Repair harness or connectors.

Check idle mixture ratio. (See CHART 2.)

*2WD: cold
4WD: hot

CHART 4

Measuring Idle CO in Tail Pipe

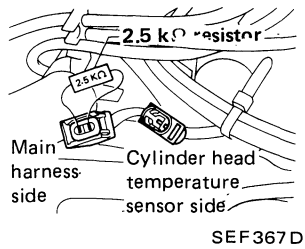

INSPECTION START

- 1) Disconnect cylinder head temperature sensor harness connector.
- 2) Connect a resistor (2.5 kΩ) between terminals of cylinder head temperature sensor harness connector.
- 3) Disconnect exhaust gas sensor harness connector.
- 4) Disconnect hot A.I.V. hose from A.I.V. pipe and install a suitable plug.
- 5) Disconnect cold A.I.V. hose and install a suitable plug.

Start engine and warm up engine until water temperature indicator points to the middle of gauge.

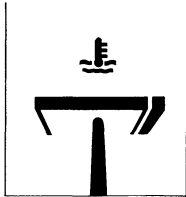

Run engine at about 2,000 rpm for about 2 minutes under no-load.

Race engine two or three times under no-load and then run engine at idle speed.

Check CO%.
Idle CO: 0.2 - 5.0% (in tail pipe)

Stop engine.

- 1) Disconnect the resistor from terminals of cylinder head temperature sensor harness connector.
- 2) Connect cylinder head temperature sensor harness connector to cylinder head temperature sensor.

Replace exhaust gas sensor.

Return to **CHART 2**.

Check fuel pressure.
(See page EF & EC-217.)

Check air flow meter.
(See pages EF & EC-96.)

Check injector.
(See pages EF & EC-118, 120.)
Clean or replace if necessary.

Check cylinder head temperature sensor.
(See page EF & EC-98.)

Reinstall any part removed or reconnect any part disconnected.

CHART 4

Measuring Idle CO in Tail Pipe

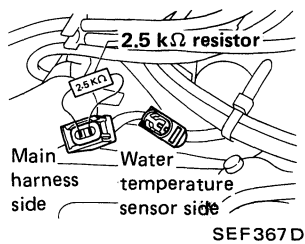

INSPECTION START

- 1) Disconnect water temperature sensor harness connector.
- 2) Connect a resistor (2.5 kΩ) between terminals of water temperature sensor harness connector.
- 3) Disconnect exhaust gas sensor harness connector.
- 4) Disconnect hot A.I.V. hose from A.I.V. pipe and install a suitable plug. (4WD)
Disconnect cold A.I.V. hose and install a suitable plug. (2WD)

Start engine and warm up engine until water temperature indicator points to the middle of gauge.

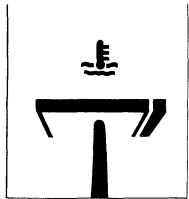

SEF355D

Run engine at about 2,000 rpm for about 2 minutes under no-load.

Race engine two or three times under no-load and then run engine at idle speed.

Check CO%.
Idle CO: 1.0 - 7.0% (in tail pipe)

O.K.

N.G.

Stop engine.

- 1) Disconnect the resistor from terminals of water temperature sensor harness connector.
- 2) Connect water temperature sensor harness connector to water temperature sensor.

Replace exhaust gas sensor.

Return to **CHART 2**.

Check fuel pressure.
(See page EF & EC-217.)

Check air flow meter.
(See page EF & EC-150.)

Check injector.
(See pages EF & EC-172, 180.)
Clean or replace if necessary.

Check water temperature sensor.
(See page EF & EC-152.)

Reinstall any part removed or reconnect any part disconnected.

Harness connector of

- Two injectors (VG30i)
- Injector (Z24i)
- F.I.C.D. solenoid valve
- Idle-up solenoid valve

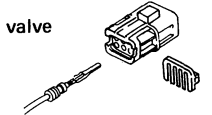

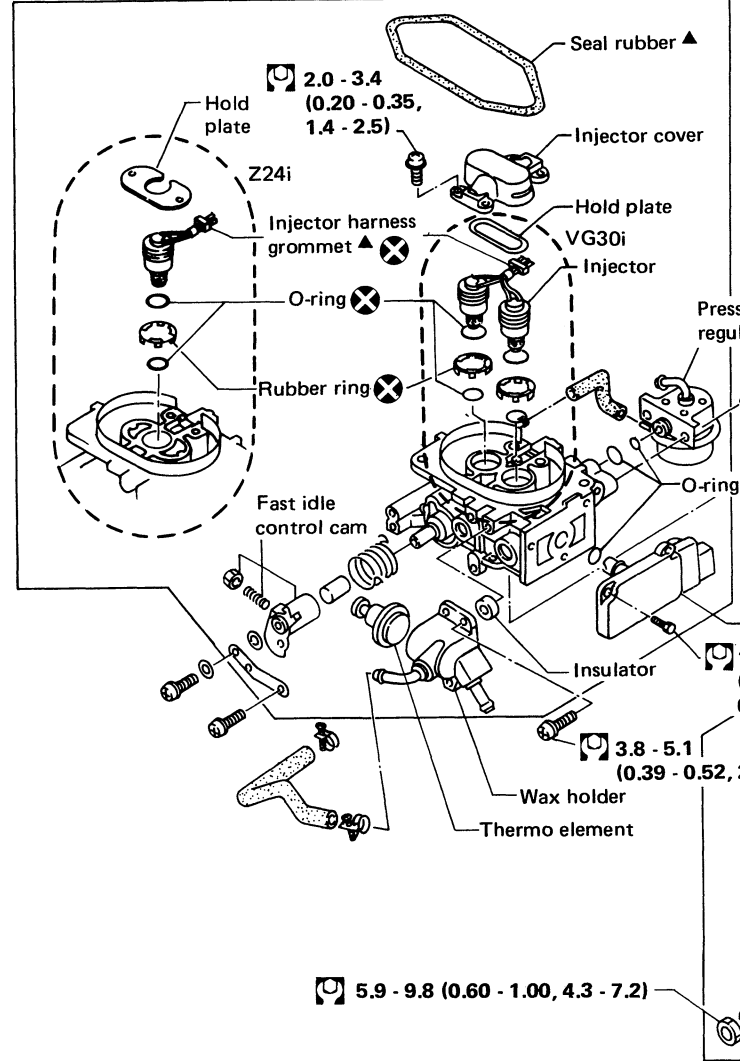

▲ : Always apply same silicone bond when reinstalled.
Some silicone oil should be applied to O-ring when reinstalled.

VENTURI CHAMBER

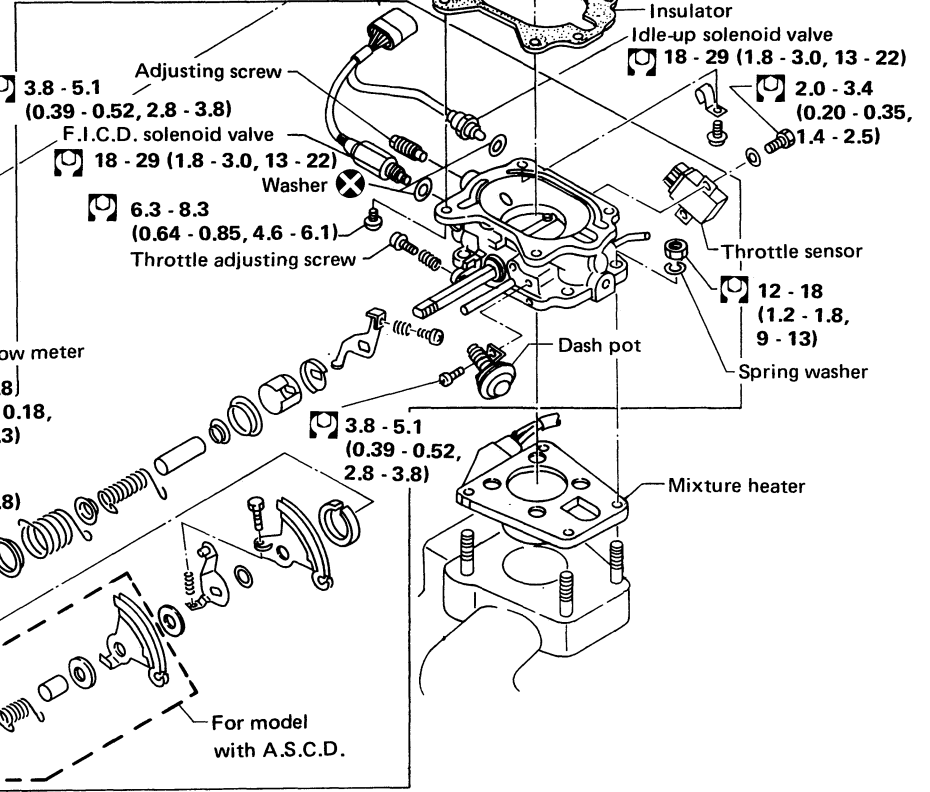

THROTTLE CHAMBER



 : N·m (kg·m, ft·lb)

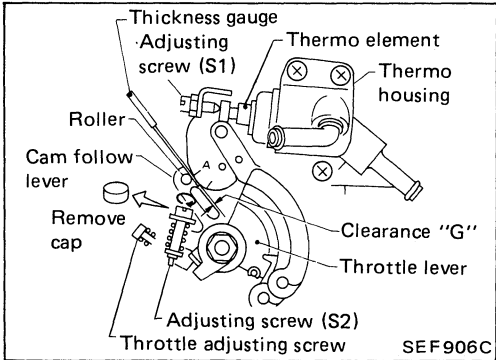
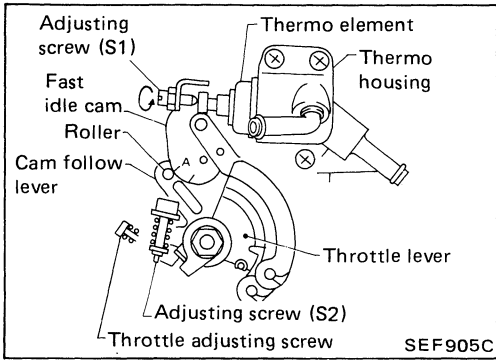

Fast Idle Inspection and Adjustment

1. Warm up the engine sufficiently.
2. Make sure that the aligning mark stamped on the fast idle cam meets the center of the roller installed on the cam follow lever.
If not, correct the location of the fast idle cam by turning the adjusting screw (S1).
If not adjustable, replace the thermo element.
3. Check the clearance "G" between the roller and the fast idle cam.

Clearance "G":

VG30i: 0.5 - 3.0 mm (0.020 - 0.118 in)

Z24i: 0.7 - 3.0 mm (0.028 - 0.118 in)

If not, correct the clearance "G" by turning the adjusting screw (S2).

Adjust clearance "G":

VG30i: 0.8 - 1.2 mm (0.031 - 0.047 in)

Z24i: 1.2 - 1.6 mm (0.047 - 0.063 in)

Make sure that the engine has sufficiently been warmed up when adjusting clearance "G".

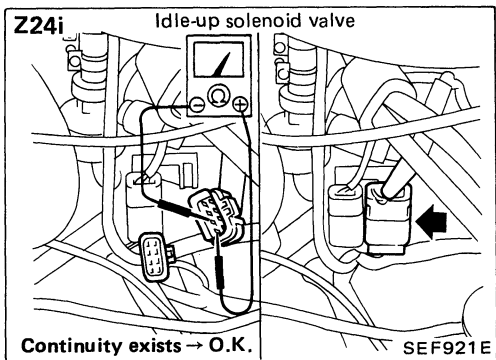
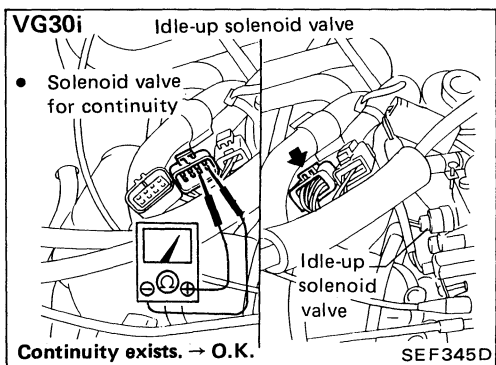

Idle-up Solenoid Valve Inspection

Subject the idle up solenoid valve to independent inspection.

1. Disconnect the 8-pin connector.
2. Check the solenoid valve for electric continuity.
Continuity should exist.

Idle-up Solenoid Valve Inspection (Cont'd)

If the electric continuity does not exist, replace it with new one.

-  : Idle-up solenoid valve
 18 - 29 N·m
 (1.8 - 3.0 kg-m, 13 - 22 ft-lb)

CAUTION:

Use a new washer when removing solenoid valve.

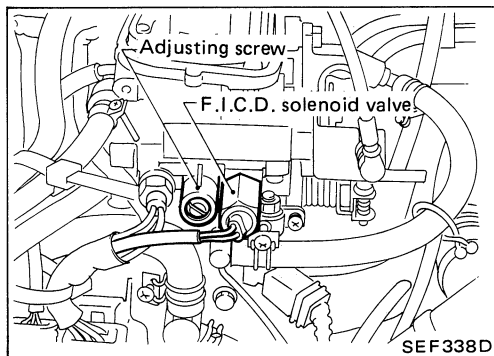
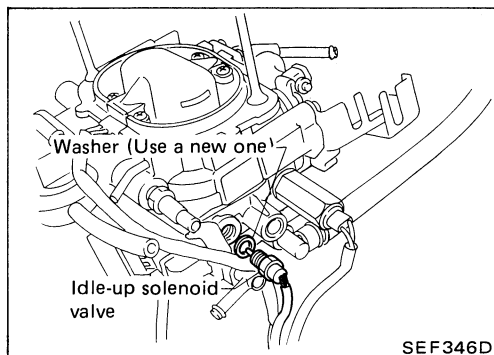

F.I.C.D. Inspection and Adjustment

1. Warm up the engine sufficiently.
2. Check idle speed.

Idle speed:

VG30i:

800±50 rpm (M/T)

700±50 rpm (A/T, in "D" position)

Z24i:

800±50 rpm (M/T)

650±50 rpm (A/T, in "D" position)

3. Turn the air conditioner switch "ON", and check idle speed.
 Idle speed (When A/C is "ON"):
 900±50 rpm (in "N" position)
4. If out of specification, adjust idle speed by turning the adjusting screw.

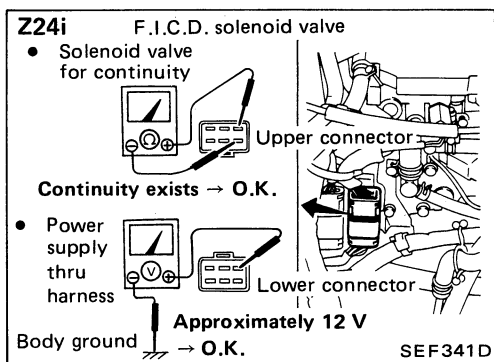
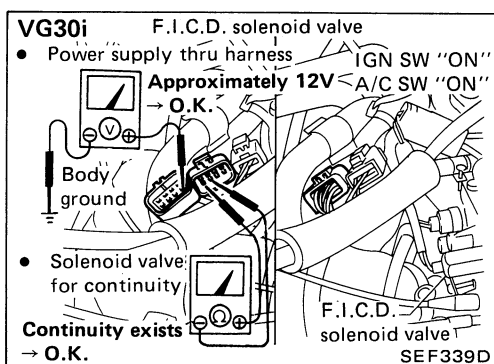

5. If the F.I.C.D. solenoid valve does not work, check the harness and the solenoid valve as follows.

- 1) Disconnect the 8-pin connector.
- 2) Check the following points.
 - The power supply through the harness with the ignition switch "ON", and the air conditioner switch "ON".
 - The electric continuity of the solenoid valve.

F.I.C.D. Inspection and Adjustment (Cont'd)

6. Replace the solenoid valve with a new one, if it has no electric continuity in spite of enough power supply.

: F.I.C.D. solenoid valve
 18 - 29 N·m
 (1.8 - 3.0 kg·m, 13 - 22 ft·lb)

CAUTION:

Use a new washer when removing solenoid valve.

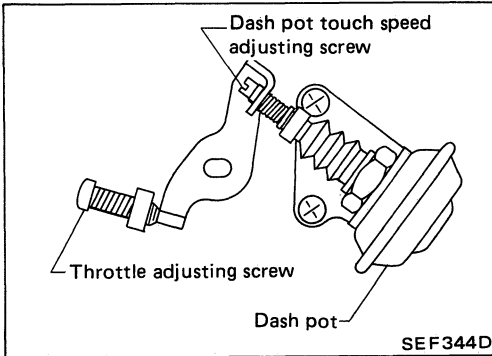
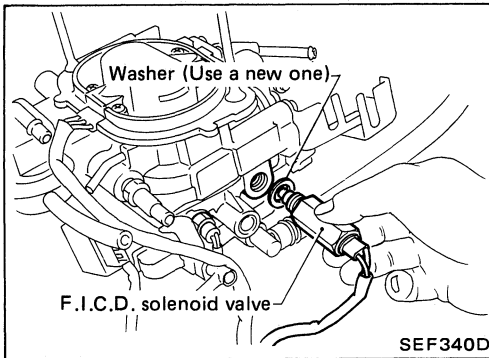

Dash Pot Inspection and Adjustment

1. The idle speed of the engine must be well tuned, and the engine warmed up to normal operation.
2. Turn the throttle valve by hand, and read the engine speed when the dash pot just touches the adjusting screw.

Dash pot touch speed:

VG30i: M/T 1,600 - 1,800 rpm

 A/T 2,000 - 2,200 rpm

Z24i: 2,700 - 3,300 rpm

- 3.

- If out of the specification, adjust it by turning the adjusting screw. (VG30i)

- Adjustment for dash pot of Z24i is as shown below. (Z24i)

- (1) Turn the adjusting screw until it touches the dash pot.

Throttle valve must be closed.

- (2) Then turn the adjusting screw 4 more turns.

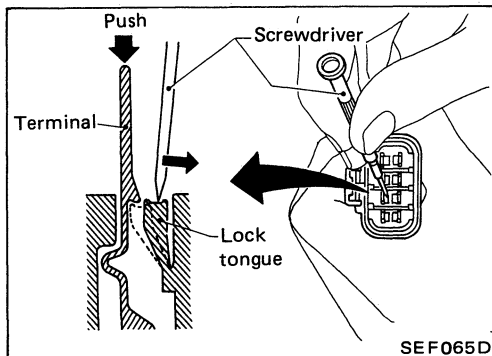
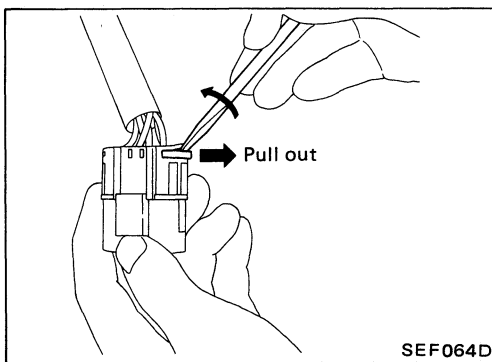

How To Disassemble Harness Connector (Type W)

1. Remove the terminal retainer.

2. With a small screwdriver, tilt the lock tongue and, at the same time, push out the terminal.

CAUTION:

- When extracting terminal, do not pull wire harness. Always push the tip of terminal.

- Take care not to damage seal boot at the bottom of terminal.

- Do not let oil or gasoline contaminate seal boot.

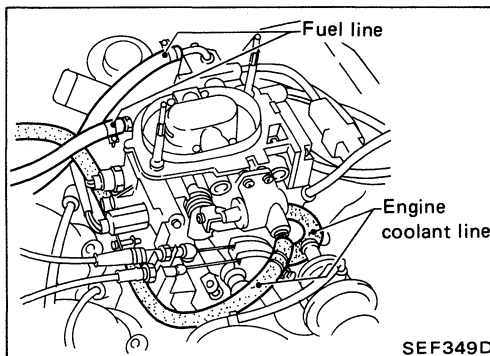
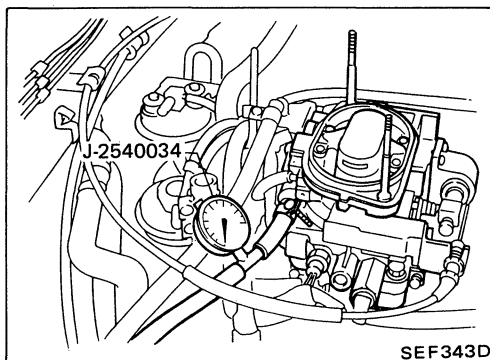
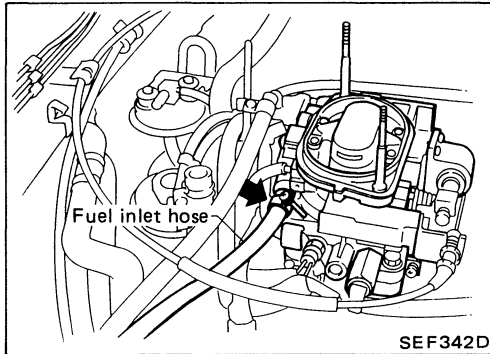
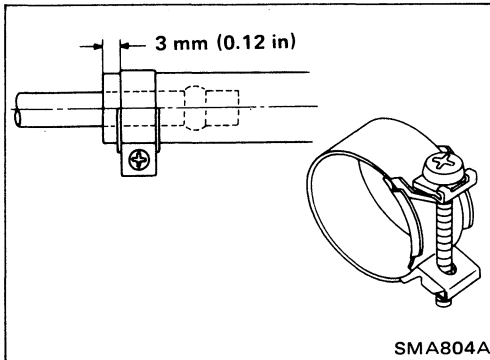
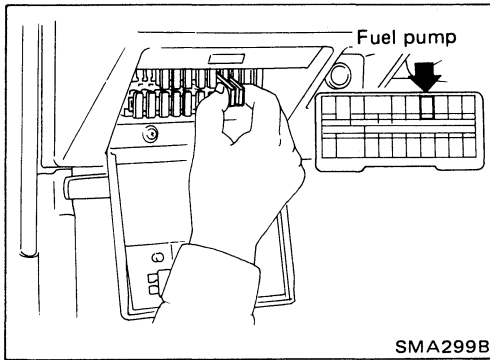

Releasing Fuel Pressure

Before disconnecting fuel line, release fuel pressure from fuel line to eliminate danger.

- (1) Disconnect the fuse for the fuel pump.
- (2) Start the engine.
- (3) After the engine stalls, crank the engine twice or three times.
- (4) Turn the ignition switch "OFF".

Fuel Pressure Check

- a. Tighten the clamp so its end is 3 mm (0.12 in) from the hose end.
- b. Make sure that the screw of the clamp does not contact with any adjacent parts.
- c. Use Pressure Gauge to check fuel pressure.

 : Fuel hose clamps
 1.0 - 1.5 N·m
 (0.10 - 0.15 kg·m, 0.7 - 1.1 ft·lb)

1. Release fuel pressure.
2. Disconnect the fuel inlet hose at the electro injection unit.

3. Install a pressure gauge.
4. Start the engine and check the fuel line for fuel leakage.
5. Read fuel pressure gauge.

At idling speed:
 Approximately 250.1 kPa
 (2.55 kg/cm², 36.3 psi)

6. Release fuel pressure again.
7. Remove the pressure gauge from the fuel line.
8. Reconnect the fuel inlet hose.

Injector Removal

1. Release fuel pressure.
2. Drain approximately one liter (1-1/8 US qt, 7/8 Imp qt) of the engine coolant.

Injector Removal (Cont'd)

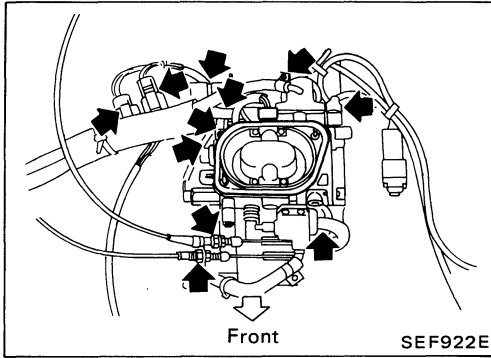

3. Remove or disconnect the following parts.
 - Air cleaner
 - Harness connectors for throttle sensor, idle switch, injectors and air flow meter.
 - Accelerator wire
 - A.S.C.D. wire (if equipped)
 - Fuel hose
 - Coolant hose

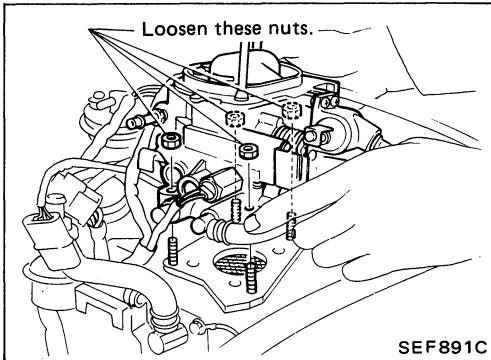

4. Remove the injection body from the intake manifold.

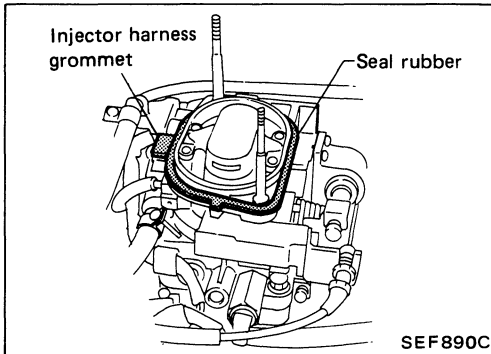

5. Remove the seal rubber and the injector harness grommet from the injection body.

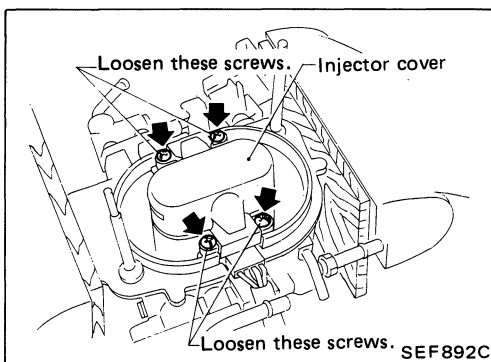

6. Remove the injector cover.

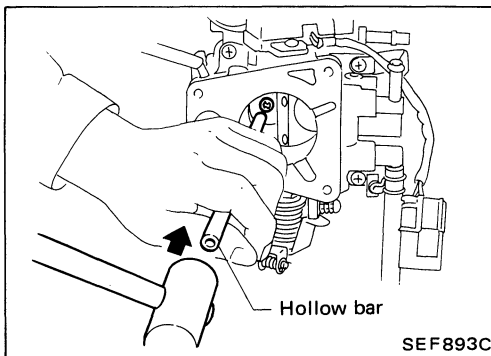

7. With the throttle valve kept fully open, tap the bottom of the fuel injector with a hollow bar described below.

Injector Removal (Cont'd)

Hollow bar:

A hollow bar as shown left is recommended for removing injectors.

Do not use a bar with an inside diameter of less than 5.5 mm (0.217 in).

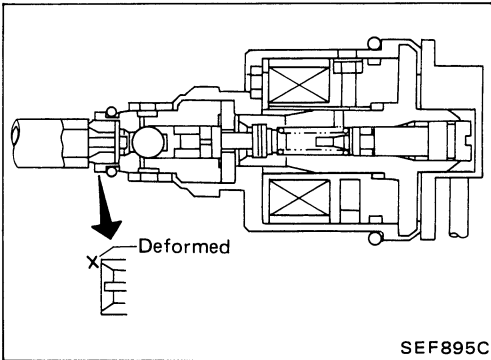
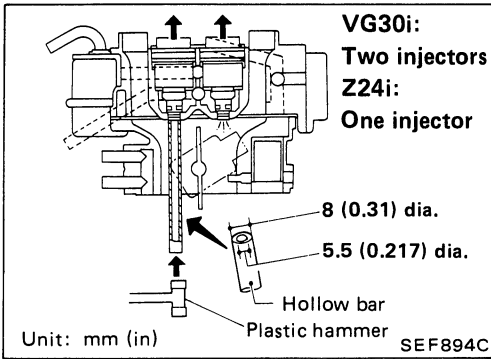

CAUTION:

If an injector nozzle tip is deformed by the bar, the injector should be replaced.

Injector Replacement and Reinstallation

1. Disconnect the harness of a malfunctioning injector from the harness connector.
See page EF & EC-216.

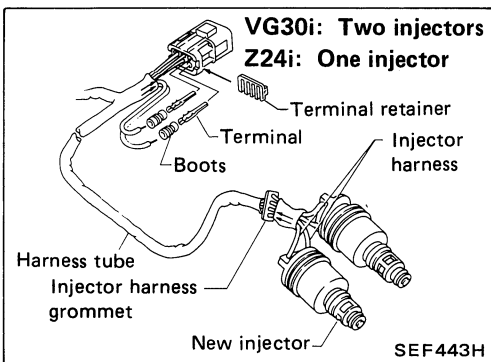
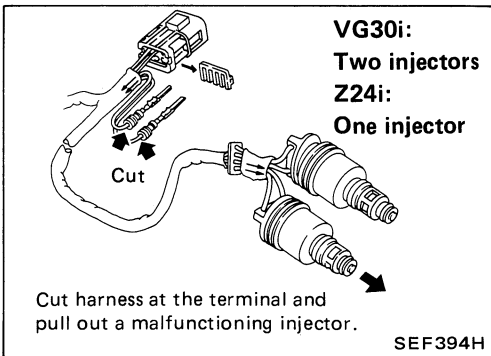

2. Put the harness of a new injector into the injector harness grommet* and the harness tube.
 - Fix the boots and terminal in the harness with terminal pliers and then put the harness in the connector.
 - Put the terminal retainer into the connector.

*CAUTION:

The harness grommet should be replaced with new one every time it is removed.

Injector Replacement and Reinstallation (Cont'd)

CAUTION:

Be careful when assembling connector. Pay attention to harness color and position. Otherwise injector damage will occur.

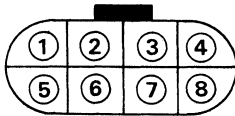

Actuator	Terminal No.	Harness color	
		VG30i	Z24i
Injector A ⊕	①	G	B
Injector A ⊖	②	W	R
Injector B ⊕	③	B	—
Injector B ⊖	④	R	—
F.I.C.D. solenoid valve ⊕	⑤	B	B
F.I.C.D. solenoid valve ⊖	⑥	B	B
Idle-up solenoid valve ⊕	⑦	B/W	B/W
Idle-up solenoid valve ⊖	⑧	B/W	B/W

A harness color of service part (injector)

Injector ⊕ : G/W

Injector A: Connect to terminal No. ①

Injector B: Connect to terminal No. ③

Injector ⊖ : Y/W

Injector A: Connect to terminal ②

Injector B: Connect to terminal ④

CAUTION:

Be sure to connect as shown above because fuel injection ratio is controlled by control unit.

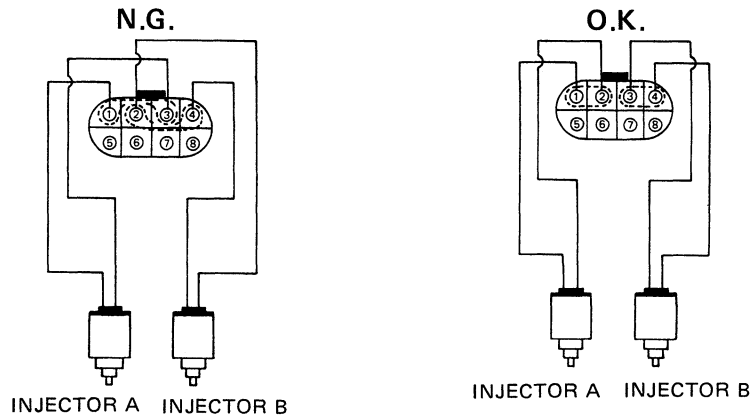

The location of injectors A and B. (VG30i only)
 Injector A is on the side of two solenoid valves.

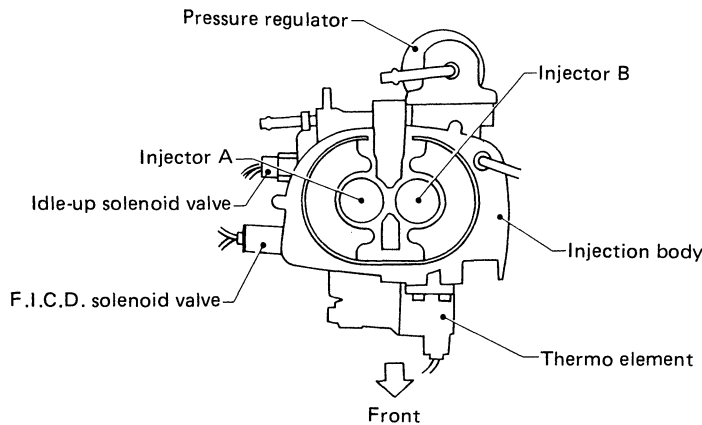

Injector Replacement and Reinstallation (Cont'd)

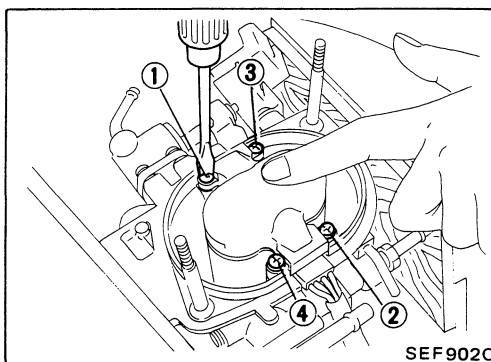
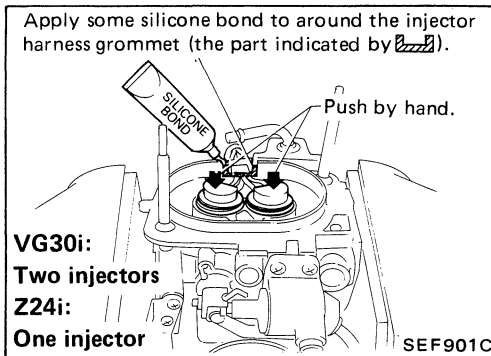
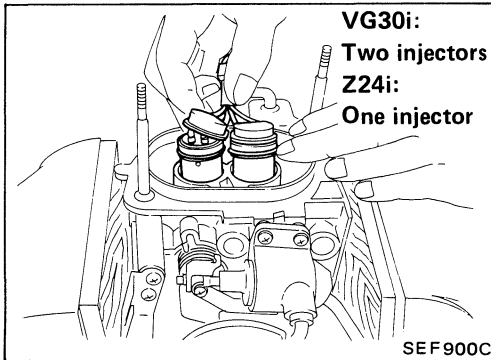
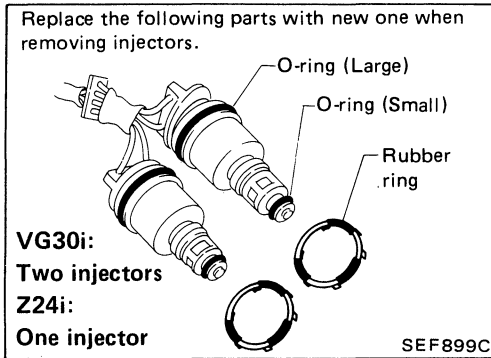

3. Replace the O-ring and rubber ring with new one.

CAUTION:

Apply some silicone oil to both O-rings when putting them into injector.

4. Put the injector assembly into the injection body.

5. Push the injectors into the injection body by hand, until the O-rings are fully seated. Invert the injection body and ensure that the injector tips are properly seated.

6. Apply some silicone bond to the injector harness grommet.

CAUTION:

Air-tight sealing is essential to ensure stable and proper idling condition.

7. Reinstall the injector cover. Be sure to use locking sealer on the screw threads.

Tighten the screws in a criss-cross* pattern to make sure of proper seating of the injector and the cover.

: Injector cover
2.0 - 3.4 N·m
(0.20 - 0.35 kg-m, 1.4 - 2.5 ft-lb)

*Tightening sequence

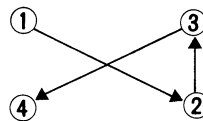

Injector Replacement and Reinstallation (Cont'd)

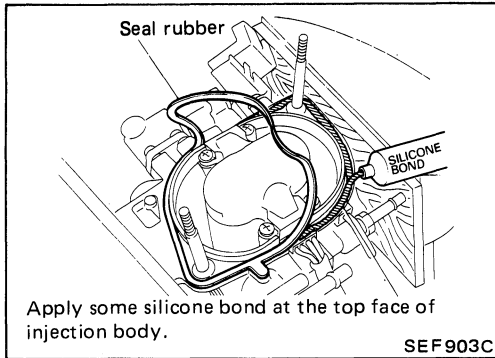

8. Attach the seal rubber to the top face of the injection body with silicone bond.

CAUTION:

- Be sure to apply some silicone bond to the bottom of the seal rubber, and adhere the seal rubber to the injection body. If not, it causes improper idling.
- Do not reinstall the air cleaner until the silicone bond has hardened.

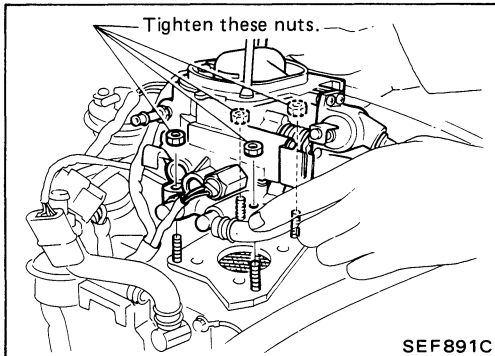

9. Reinstall the electro injection unit on the intake manifold.

 : Nut

12 - 18 N·m

(1.2 - 1.8 kg·m, 9 - 13 ft·lb)

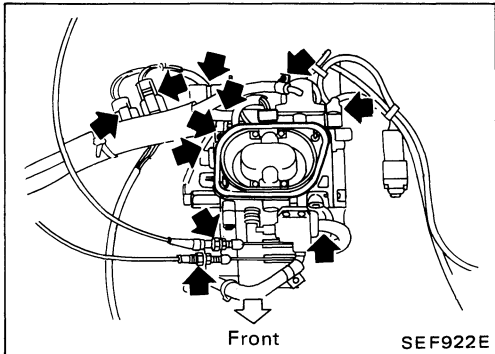

10. Reinstall or reconnect the following parts.

- Harness connectors
- Accelerator wire
- A.S.C.D. wire (if equipped)
- Coolant hose
- Fuel hose

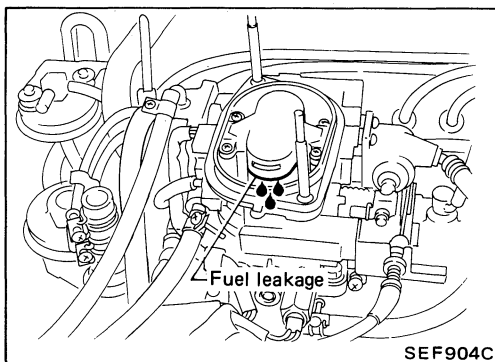

11. Start the engine, and make sure that there is no fuel leakage from the clearance between the injector cover and the injection body. Stop the engine and make sure that fuel on the throttle valve does not drip. Also be sure that engine idling condition is stable and proper.

CAUTION:

- After warming up, add approximately one liter (1-1/8 US qt, 7/8 Imp qt) of engine coolant to that in radiator.
- Take care when opening radiator cap to avoid being scalded.

12. Perform the mixture ratio feedback system inspection to make sure there is no fuel leakage at the injector top seal.

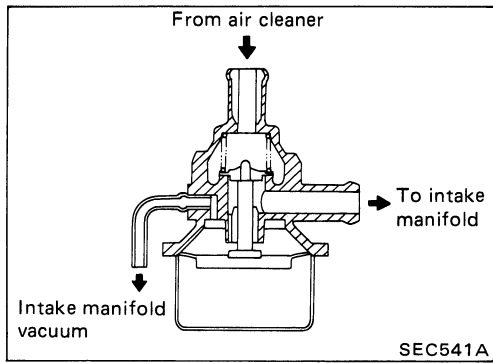

A.B. VALVE

Description

During deceleration the fuel mixture becomes excessively rich due to the high manifold vacuum which occurs when the throttle closes. This excess fuel is passed through to the exhaust where it combines with the air supplied by the air induction valve, causing afterburn or backfire. In addition to afterburn, the excessively rich mixture creates unnecessary hydrocarbon emissions.

To prevent this condition, the A.B. valve is designed to sense high manifold vacuum and open an air passage into the intake manifold. This extra air introduced into the intake manifold leans out the fuel mixture before it can pass into the exhaust manifold, preventing both backfire and excessive HC emissions.

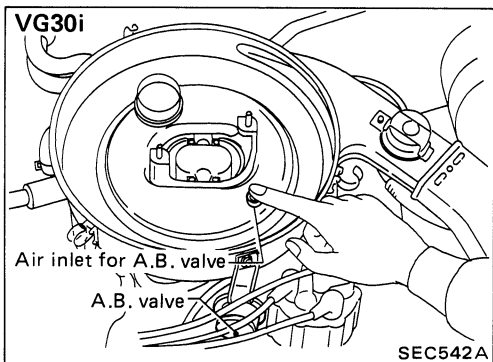

Inspection

1. Warm up the engine.
2. Remove the air cleaner cover and the air cleaner filter.
3. Run the engine at approximate 3,000 rpm under no load, then quickly return it to idling. If you feel pull or suction force on your finger, the A.B. valve is functioning normally. If no suction is felt, replace the A.B. valve with new one.

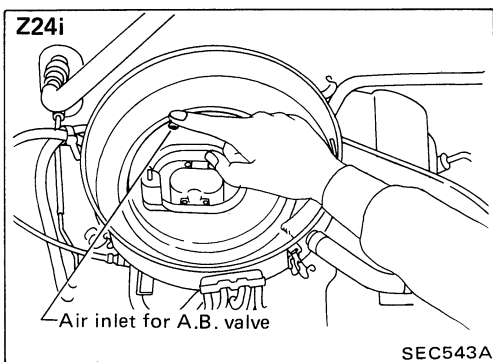

Description

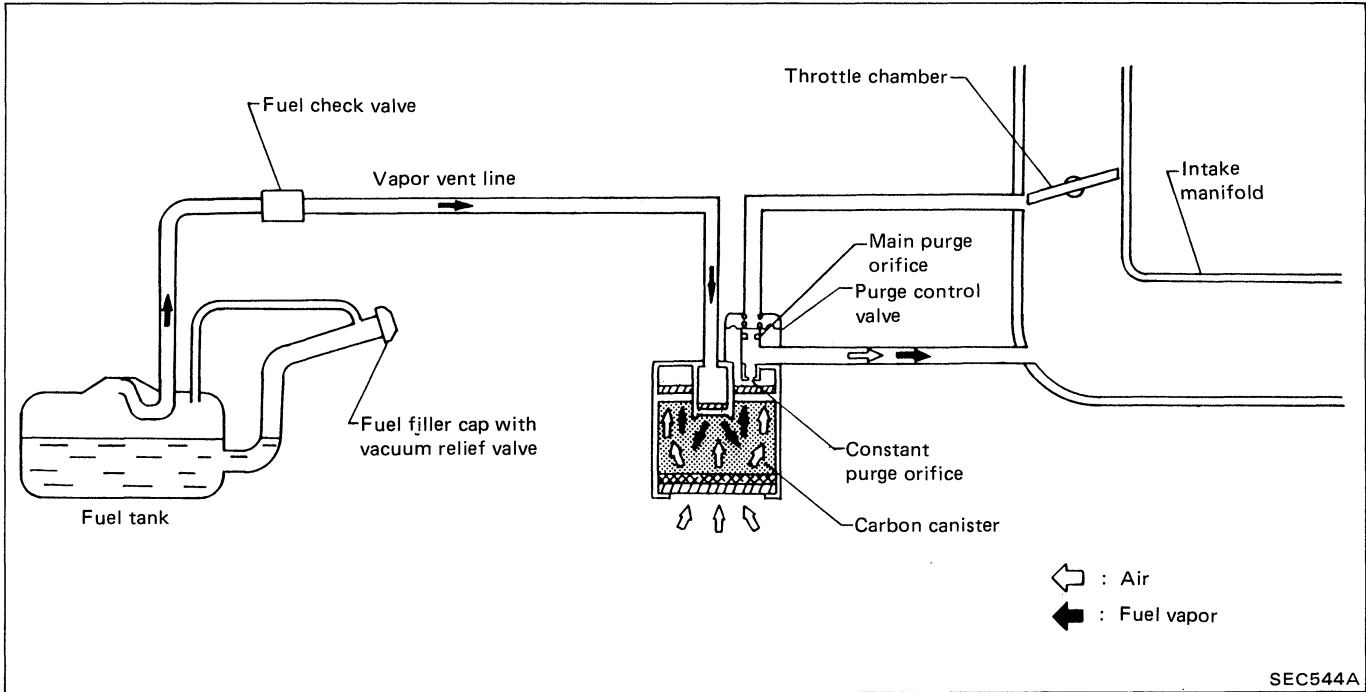

The evaporative emission control system is used to reduce hydrocarbons emitted to the atmosphere from the fuel system. This reduction of hydrocarbons is accomplished by activated charcoals in the carbon canister.

The fuel vapor from the sealed fuel tank is led into the canister which contains activated carbon and the vapor is stored there when the engine is not running.

The canister retains the fuel vapor until the canister is purged by the air drawn through the bottom of the canister to the intake manifold when the engine is running. When the engine runs at idle, the purge control valve is closed.

Only a small amount of stored vapor flows into the intake manifold through the constant purge orifice. As the engine speed increases, and the throttle vacuum rises higher, the purge control valve opens and the vapor is sucked into the intake manifold through both the main purge orifice and the constant purge orifice.

Inspection

CARBON CANISTER

Check carbon canister as follows.

- (A) : Blow air and ensure that there is no leakage.
- (B) : Blow air and ensure that there is leakage.

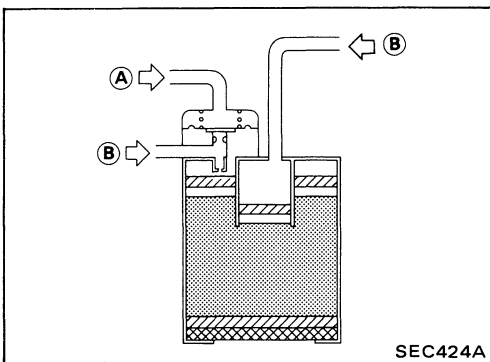

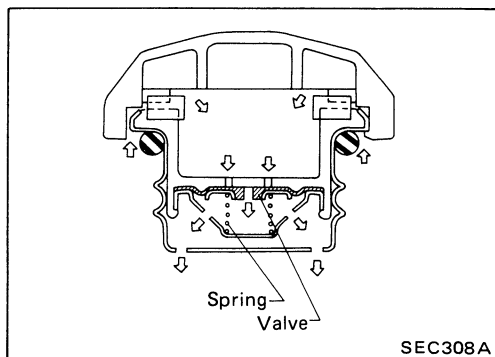

Inspection (Cont'd)

FUEL TANK VACUUM RELIEF VALVE

1. Wipe clean valve housing.
2. Inhale air through the cap. A slight resistance accompanied by valve clicks indicates that valve is in good mechanical condition. Note also that, by further inhaling air, the resistance should be disappeared with valve clicks.
3. If valve is clogged, or if no resistance is felt, replace cap as an assembly.

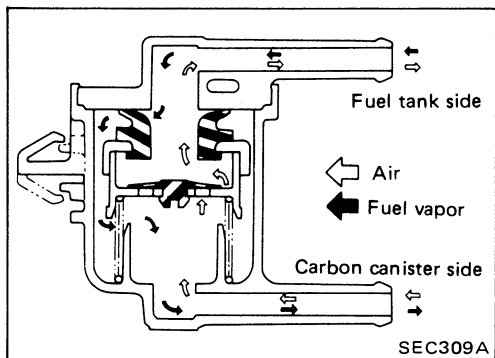

FUEL CHECK VALVE

1. Blow air through connector on fuel tank side. A considerable resistance should be felt and a portion of air flow be directed toward the canister.
2. Blow air through connector on the canister side. Air flow should be smoothly directed toward fuel tank.
3. If fuel check valve is suspected of not being properly functioning in steps 1 and 2 above, replace it.

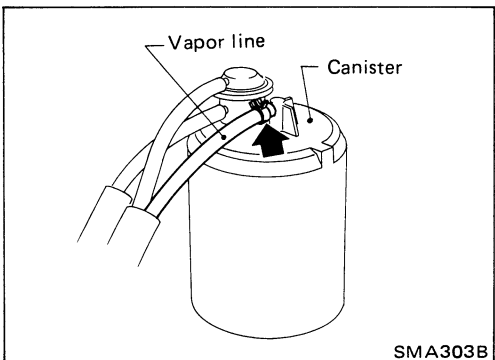

VAPOR VENT LINE

1. Check hoses and fuel tank filler cap.
2. Disconnect the vapor vent line connecting carbon canister to fuel tank.

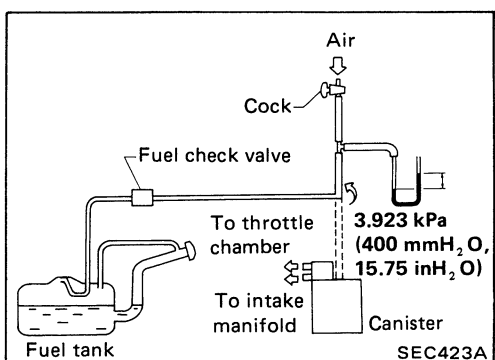

3. Connect a 3-way connector, a manometer and a cock (or an equivalent 3-way charge cock) to the end of the vent line.
4. Supply fresh air into the vapor vent line through the cock little by little until pressure becomes 3.923 kPa (400 mmH₂O, 15.75 inH₂O).
5. Shut the cock completely and leave it unattended.
6. After 2.5 minutes, measure the height of the liquid in the manometer.
7. Variation in height should remain at 0.245 kPa (25 mmH₂O, 0.98 inH₂O).
8. When filler cap does not close completely, the height should drop to zero in a short time.
9. If the height does not drop to zero in a short time when filler cap is removed, the cause is a blocked hose or a clogged fuel check valve.

In case the vent line is blocked, the fuel tank is not vented properly causing insufficient deliver of fuel to engine, or vapor lock. It must, therefore, be repaired.

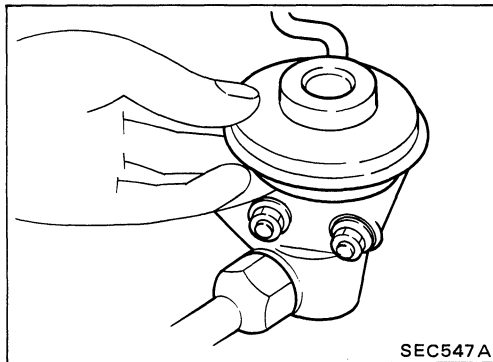
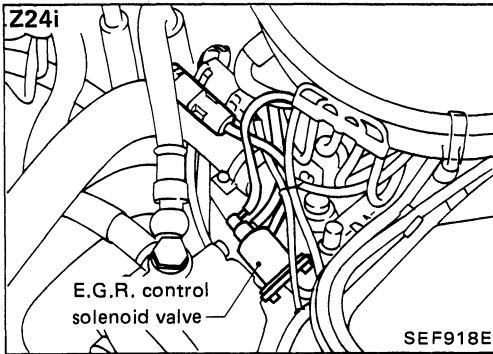
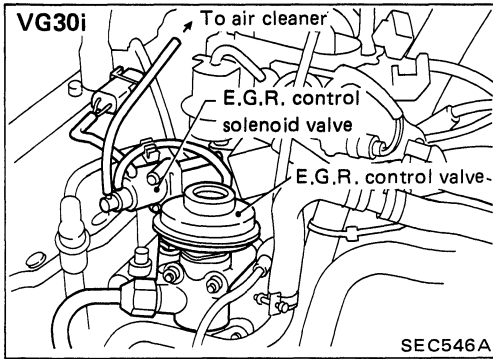

E.G.R. SYSTEM

1. Check the vacuum hoses for loosening, flattening damage or faulty connections.
 - Replace, if necessary.

2. Remove the air cleaner, and warm up the engine sufficiently.
3. With the engine running, inspect the E.G.R. control system operation, referring to the operation table shown below. When checking the valve operation, place a finger on the diaphragm of the valve.

Engine rev Approximately (rpm)	1,000		3,000	
E.G.R. control valve operation	OFF	ON	OFF	OFF

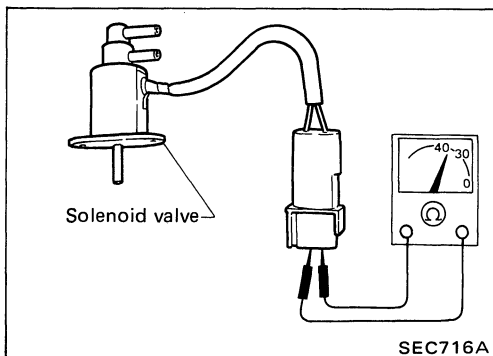

E.G.R. CONTROL SOLENOID VALVE

1. Check the solenoid valve for electric continuity, after disconnecting the harness connector.

Resistance: 30 - 40Ω

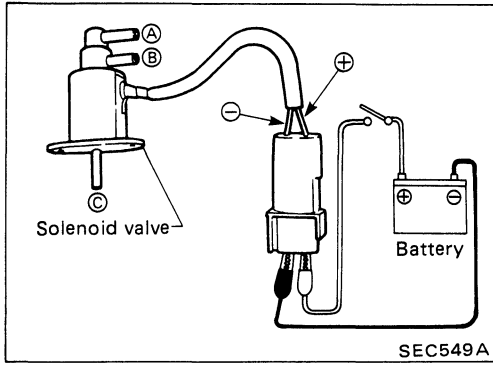

2. Check the solenoid valve for normal operation, after disconnecting the harness connector and all the vacuum hoses. Supply the solenoid valve with battery voltage, and check whether there is continuity between ports A, B and C.

	Solenoid valve	
Item	OFF	ON
Continuity	B-C	A-B

CAUTION:

- Be sure to connect ⊕ terminal of battery with white harness of solenoid valve.
- Perform E.G.R. circuit test. (See page EF & EC-104/158.)
- Perform E.C.U. input/output signal inspection. (See page EF & EC-200.)

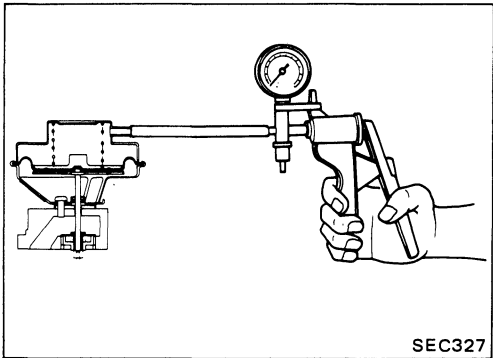

E.G.R. CONTROL VALVE

1. Supply the E.G.R. control valve with vacuum using a handy vacuum pump.
2. Place a finger on the diaphragm of the valve, and make sure that the diaphragm lifts up and down in response to the vacuum leading to the valve.

Full open of E.G.R. valve:

Over -16.0 kPa
 (-120 mmHg, -4.72 inHg)

AUTOMATIC TEMPERATURE CONTROL (A.T.C.) SYSTEM

VG30i Z24i

Description

The automatic temperature control system maintains the temperature of air entering the electro injection unit within a constant range, thereby enabling lean setting for the injection unit calibration. In addition to this, the automatic temperature control system is effective in improving the warm-up characteristics of the engine and in preventing the injection unit from icing.

Operation

Temperature sensor	Intake manifold vacuum kPa (mmHg, inHg)	*Control vacuum kPa (mmHg, inHg)	Vacuum motor	Inlet air
Ambient temperature around sensor approximately °C (°F)			Operation	
Below 38 (100)	Above 22.0 (165, 6.50)	Above 22.0 (165, 6.50)	Raised	Hot
	10.0 - 22.0 (75 - 165, 2.95 - 6.50)	Equal to intake manifold vacuum	Partially raised	Cool + Hot
	Below 10.0 (75, 2.95)		Down	Cool
Between 38 (100) and 48 (118)	Any value	Above 10.0 (75, 2.95)	Partially raised	Cool + Hot
Above 48 (118)		Below 10.0 (75, 2.95)	Down	Cool
		Below 10.0 (75, 2.95)	Down	Cool

*Control vacuum means vacuum which actuates vacuum motor.

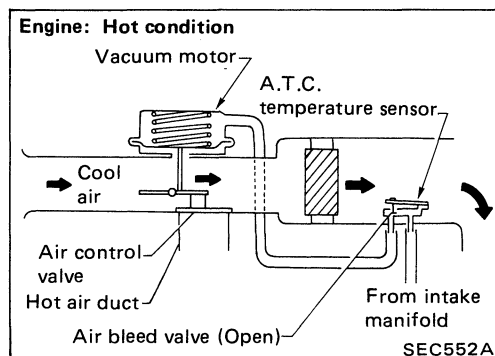
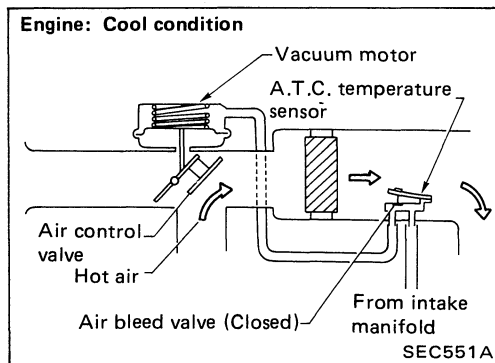

The automatic temperature control system is controlled by the inlet air temperature and the load condition of the engine. The inlet air temperature is detected by the sensor, installed in the air cleaner box, and the vacuum motor is actuated by the intake manifold vacuum.

When the engine itself is not warmed up enough, since the A.T.C. temperature sensor passes the intake manifold vacuum to the vacuum motor, the motor actuates and hot air is introduced into the air cleaner. In this step, the higher the intake manifold vacuum is, the wider the air control valve opens.

When the engine is warmed up, the A.T.C. temperature sensor releases to the atmosphere the intake manifold vacuum leading to the vacuum motor. Therefore the vacuum motor is inactivated, finally it does not actuate. In this step, the air control valve shuts off hot air, instead of that, normal temperature air goes to the air cleaner.

AUTOMATIC TEMPERATURE CONTROL (A.T.C.) SYSTEM

VG30i

Z24i

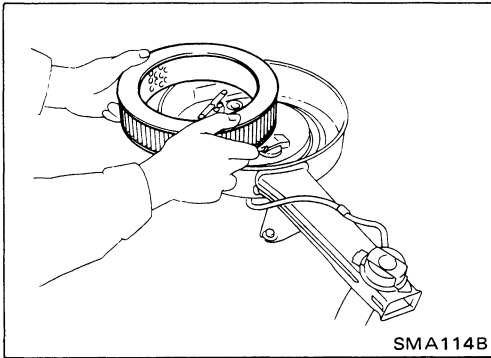

Inspection

AIR CLEANER FILTER (Viscous paper type)

Viscous paper type air cleaner filter does not require any cleaning operation until it is replaced periodically. Brushing or blasting operation should never be conducted, because it causes clogging and results in enrichment of the mixture ratio.

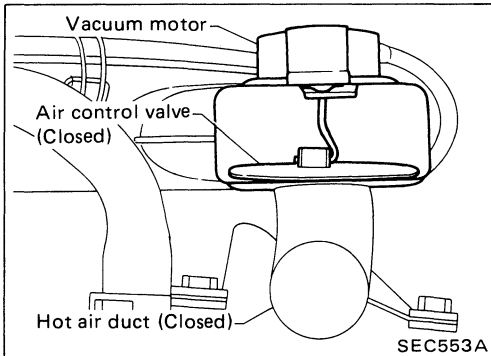

AUTOMATIC TEMPERATURE CONTROL SYSTEM

- Engine stall or hesitation
- Increase in fuel consumption
- Lack of power

If these phenomena should occur, check the A.T.C. system before carrying out the inspection of the electro injection unit.

1. Check the hoses for cracks, distortion and improper position.
2. Check A.T.C. system for proper function, while the engine is cool. Check the air control valve position.

The air control valve is correct if it is in lower position.

3. Start the engine and immediately check the air control valve position. If it rises, it is correct.
4. Make sure that the air control valve moves up and down when the engine speed is quickly increased and decreased.
5. Make sure that the air control valve partially rises when the engine warm-up advances.

If the above test reveals any problem in the operation of air control valve, carry out the following test:

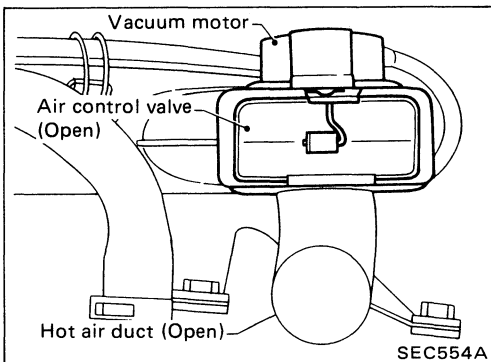

VACUUM MOTOR

Disconnect the inlet vacuum hose of the vacuum motor, and connect another hose to the inlet to apply vacuum to the vacuum motor. Then, confirm that the air control valve moves.

Air control valve operating vacuum:

kPa (mmHg, inHg)

Opening starts

-10.0 (-75, -2.95)

Full opening

Over -22.0 (-165, -6.50)

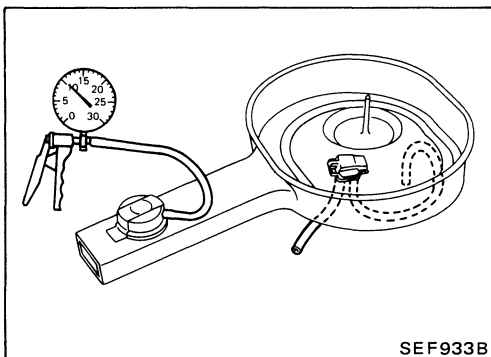

TEMPERATURE SENSOR

While the engine is cool and idling, disconnect the inlet vacuum hose of the vacuum motor and make sure that intake manifold vacuum is present at the end of the vacuum hose. If vacuum is weak or is not present at all, check the vacuum hose for leakage.

Replace the temperature sensor if the vacuum hoses are in good order. And after the engine warms up, make sure that no vacuum is present there. If any, replace the temperature sensor.

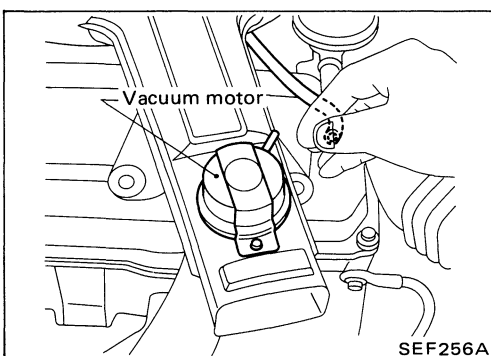

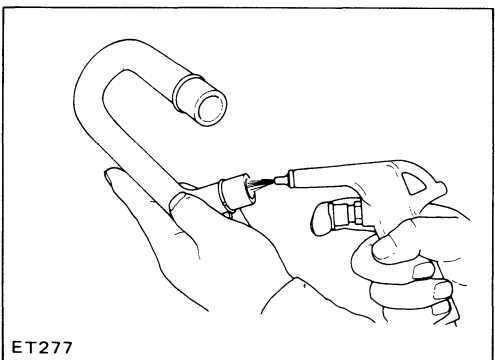
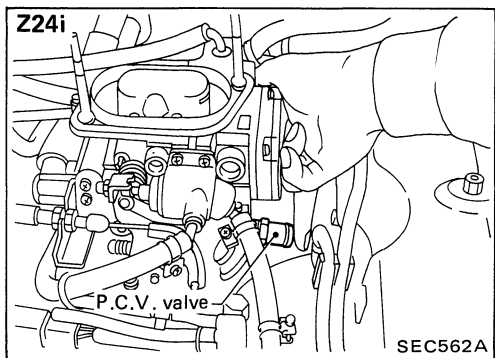
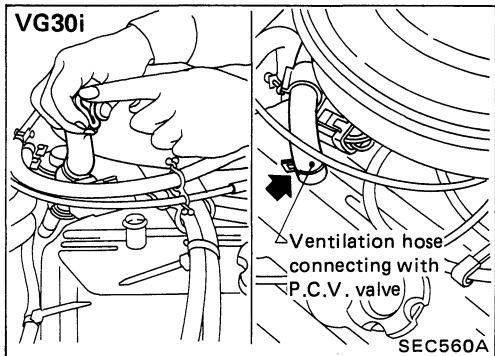
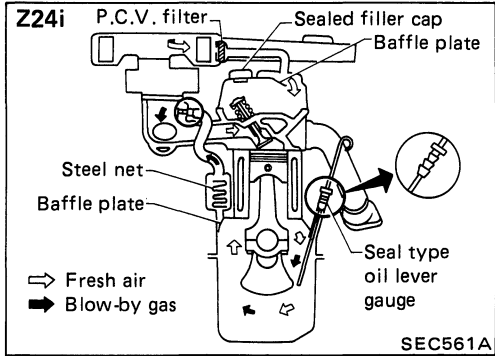
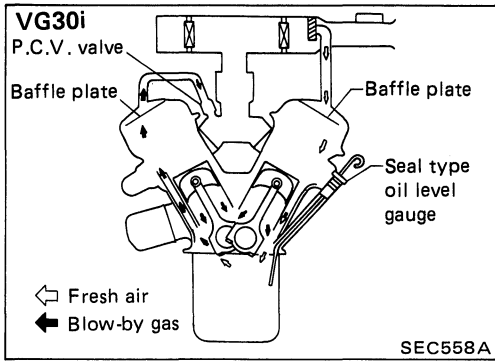

Description

This system returns blow-by gas to both the intake manifold and air cleaner.

The positive crankcase ventilation (P.C.V.) valve is provided to conduct crankcase blow-by gas to the intake manifold.

During partial throttle operation of the engine, the intake manifold sucks the blow-by gas through the P.C.V. valve.

Normally, the capacity of the valve is sufficient to handle any blow-by and a small amount of ventilating air.

The ventilating air is then drawn from the air cleaner, through the hose connecting air cleaner to rocker cover, into the crankcase.

Under full-throttle condition, the manifold vacuum is insufficient to draw the blow-by flow through the valve, and its flow goes through the hose connection in the reverse direction.

On vehicles with an excessively high blow-by some of the flow will go through the hose connection to the air cleaner under all conditions.

Inspection

P.C.V. VALVE

With engine running at idle, remove ventilation hose from P.C.V. valve; if valve is working properly a hissing noise will be heard as air passes through it and a strong vacuum should be felt immediately when a finger is placed over valve inlet.

VENTILATION HOSE

1. Check hoses and hose connections for leaks.
2. Disconnect all hoses and clean with compressed air. If any hose cannot be freed of obstructions, replace.

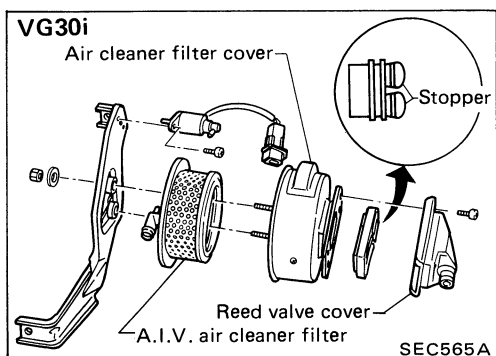
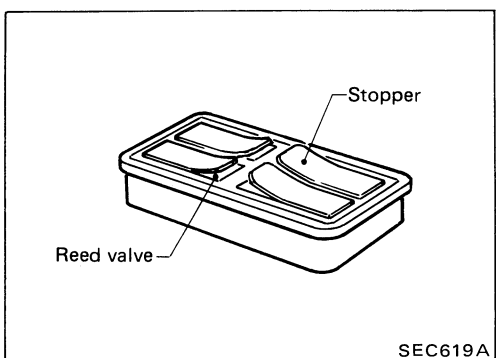
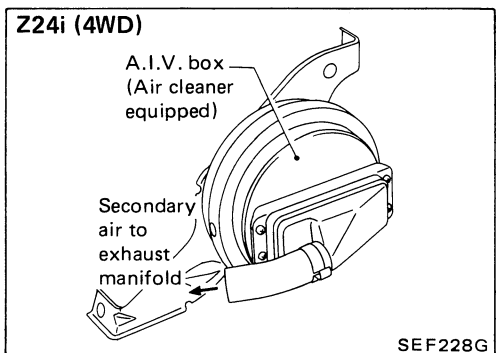
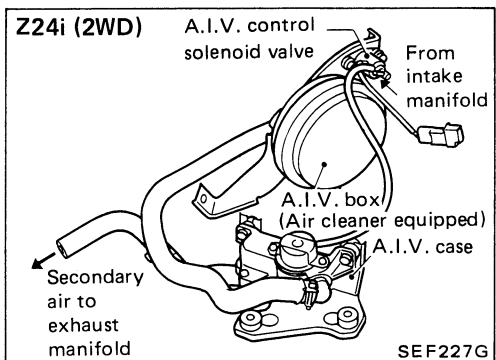
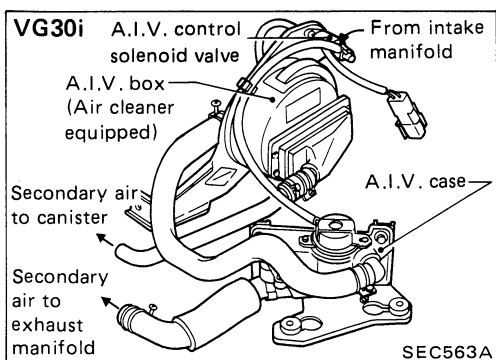

VISUAL CHECK

Check the hoses and tubes for loosening, flattening damage or faulty connections, and each part for proper installation.

- Replace, if necessary.

A.I.V. BOX (Air cleaner equipped)

1. Disconnect the air induction hose leading to the catalyst, and remove the reed valve cover.
2. Check the reed valve for breakage, cracks, or deformation, and the stopper for loosening.

3. Remove the air cleaner filter cover, and check whether the filter is too dirty.

Since the filter is a viscous paper type, it does not require any cleaning operation.

- Replace, if necessary.

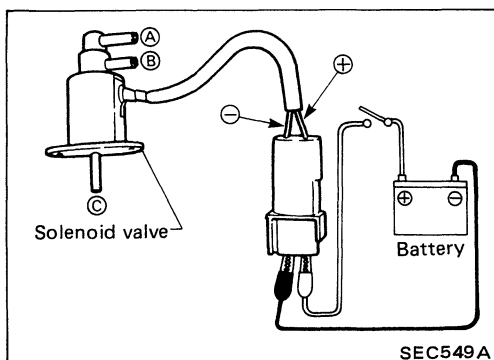
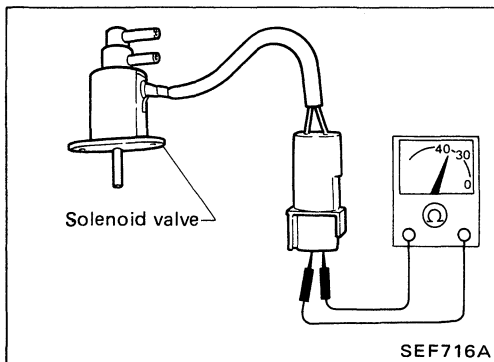
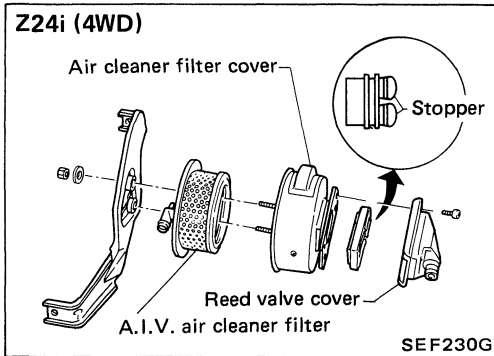
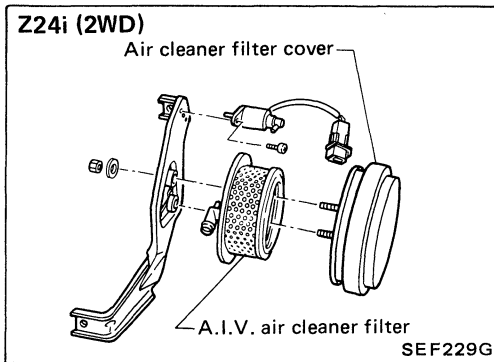

4. Subject the solenoid valve to independent inspection, after disconnecting the harness connector and all the vacuum hoses.

1) Check it for electric continuity.

Resistance: 30 - 40Ω

2) Check the solenoid valve for normal operation. Supply it with battery voltage, and check whether there is continuity between ports A, B and C.

Solenoid valve OFF: Continuity B-C

Solenoid valve ON: Continuity A-B

CAUTION:

- Be sure to connect ⊕ terminal of battery with white harness of solenoid valve.
- Perform A.I.V. circuit test. (See page EF & EC-144/194.)
- Perform E.C.U. input/output signal inspection. (See page EF & EC-200.)

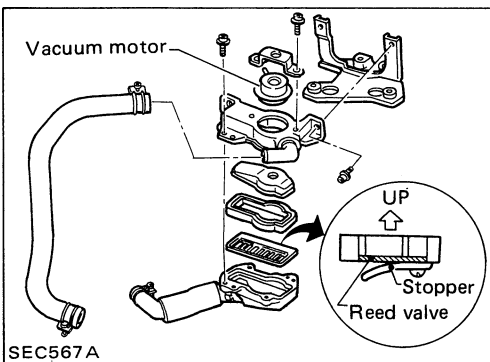
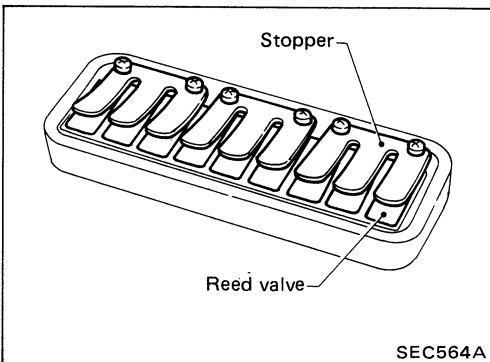
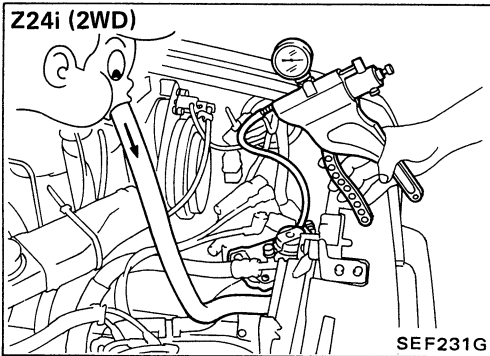
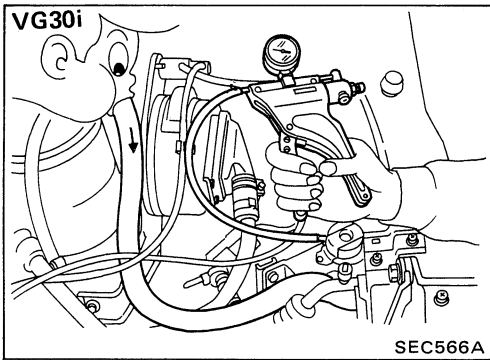

A.I.V. CASE (Vacuum motor equipped) [VG30i, Z24i (2WD)]

1. Disconnect the vacuum hose leading to the vacuum motor and set a handy vacuum pump there.
2. Disconnect the hose between the A.I.V. case and the A.I.V. box.
3. Subject the A.I.V. case to inspection in the following way.
Try to blow the A.I.V. case through the hose, when vacuum is lead to the vacuum motor and when no vacuum exists.

	Vacuum	No vacuum	Parts condition?
Can you blow?	Yes	No	O.K.
	No	Yes	N.G.

4. If the inspection shows N.G., disassemble the A.I.V. case and check such parts as the reed valve, the vacuum motor, and the connecting hose between the A.I.V. case and the A.I.V. box.

General Specifications

PRESSURE REGULATOR		
Regulated pressure		250.1 (2.55, 36.3)
	kPa (kg/cm ² , psi)	
<hr/>		
Throttle chamber		
Bore diameter	mm (in)	50 (1.97)

E.G.R. CONTROL VALVE		
	kPa (mmHg, inHg)	
Fully open vacuum		Over -16.0 (-120, -4.72)
<hr/>		
VACUUM MOTOR		
	kPa (mmHg, inHg)	
Opening starts		-10.0 (-75, -2.95)
Fully open		Over -22.0 (-165, -6.50)

Inspection and Adjustment

	VG30i	Z24i
AIR FLOW METER V		
Potentiometer voltage between terminal (B) and ground	Battery voltage	
Potentiometer voltage between terminal (D) and ground	Approximately 0.0 - 5.0	
CYLINDER HEAD/WATER TEMPERATURE SENSOR		
	kΩ	
Thermistor resistance at -10°C (14°F)	8.5 - 9.5	
at 20°C (68°F)	2.3 - 2.7	
at 50°C (122°F)	0.77 - 0.87	
at 80°C (176°F)	0.30 - 0.33	
IDLE SWITCH rpm		
Engine speed when idle switch is changed from "OFF" to "ON"	M/T: Idle speed + 250±150 A/T: Engine speed (Idle speed in "N" position) + 250±150	1,600 ⁺⁵⁵⁰ -250 (A/T: in "N" position)
FUEL PRESSURE		
	kPa (kg/cm ² , psi)	
(Measuring point: between fuel filter and injection body)		
At idling	Approximately 250.1 (2.55, 36.3)	

	VG30i	Z24i
FUEL INJECTOR Ω		
Coil resistance	Approximately 1.0	
THROTTLE SENSOR V		
Voltage between (e) and (f) when opening throttle valve	Approximately 0.5 - 4.0	
Voltage between (d) and (f)	Approximately 5.0	
FAST IDLE CAM mm (in)		
Clearance "G" between F.I.C. and roller		
for checking	0.5 - 3.0 (0.020 - 0.118)	0.7 - 3.0 (0.028 - 0.118)
for adjusting	0.8 - 1.2 (0.031 - 0.047)	1.2 - 1.6 (0.047 - 0.063)
IDLE SPEED rpm		
M/T model	800±50	800±50
A/T model in "D" position	700±50	650±50
Any model in "N" position when A/C is "ON"	900±50	900±50
IDLE CO %	0.2 - 5.0	1.0 - 7.0
DASH POT rpm		
Touch speed	M/T; 1,600 - 1,800 A/T; 2,000 - 2,200	2,700 - 3,300
VACUUM CUT SOLENOID VALVE Ω		
Coil resistance	30 - 40	

Tightening Torque

Unit	N·m	kg·m	ft·lb
E.G.R. control valve	18 - 23	1.8 - 2.3	13 - 17
E.G.R. tube securing nut	34 - 44	3.5 - 4.5	25 - 33
Catalytic converter bolt	31 - 42	3.2 - 4.3	23 - 31
Cylinder head temperature sensor	15 - 20	1.5 - 2.0	11 - 14
Air flow meter mounting bolt	1.2 - 1.8	0.12 - 0.18	0.9 - 1.3
Idle switch securing bolt	3.8 - 5.1	0.39 - 0.52	2.8 - 3.8
Idle-up solenoid valve	18 - 29	1.8 - 3.0	13 - 22
F.I.C.D. solenoid valve	18 - 29	1.8 - 3.0	13 - 22
Injector cover	2.0 - 3.4	0.20 - 0.35	1.4 - 2.5

Unit	N·m	kg·m	ft·lb
Injection body installing nut	12 - 18	1.2 - 1.8	9 - 13
Exhaust gas sensor (VG30i)	18 - 24	1.8 - 2.4	13 - 17
(Z24i)	40 - 50	4.1 - 5.1	30 - 37
Injection body installing screw	5.9 - 9.8	0.60 - 1.00	4.3 - 7.2
Fuel hose clamp	1.0 - 1.5	0.10 - 0.15	0.7 - 1.1

Fuel hose clamping position

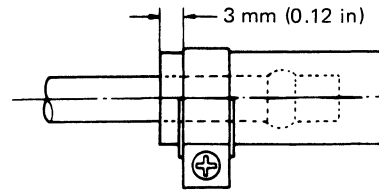

EF336A

ENGINE CONTROL, FUEL & EXHAUST SYSTEMS

SECTION **FE**

CONTENTS

ENGINE CONTROL SYSTEM	FE-2
FUEL SYSTEM	FE-3
EXHAUST SYSTEM	FE-6



ENGINE CONTROL SYSTEM

- a. Check to see if throttle valve fully opens when accelerator pedal is fully depressed and returns to idle when released.
- b. Adjust accelerator pedal free play by turning adjusting nut.
- c. On automatic transmission models, make sure kickdown switch rod is fully pushed in when accelerator pedal is depressed completely.
- d. ON A.S.C.D. equipped models, first adjust accelerator wire and then A.S.C.D. cable. For details, refer to "Automatic Speed Control Device" in EL section.
- e. Check accelerator control parts for improper contact with any adjacent parts.
- f. When connecting accelerator wire, be careful not to twist or scratch its inner wire.
- g. Apply a light coat of recommended multi-purpose grease to all sliding or friction surfaces. Do not apply grease to wire.

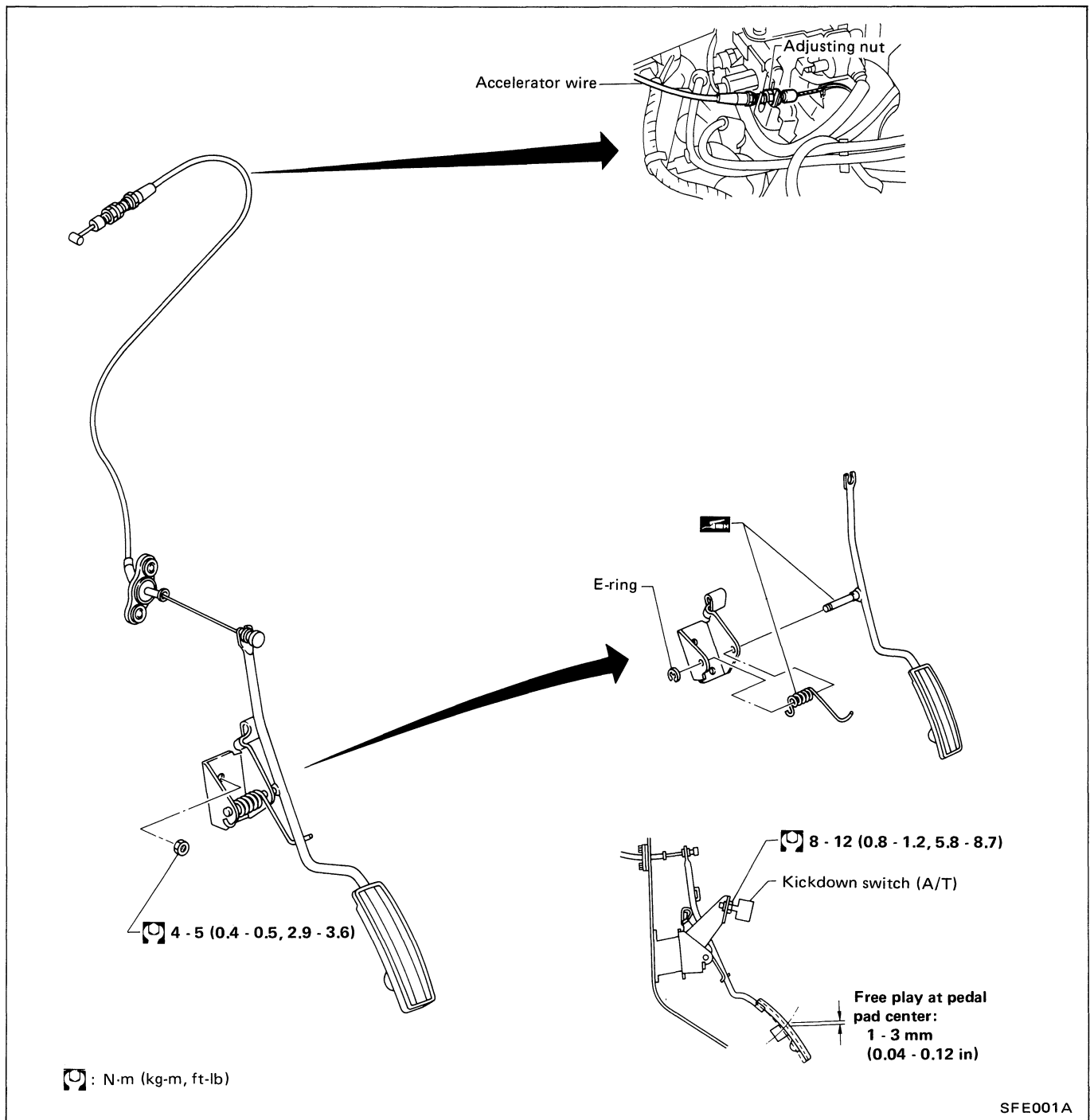

FUEL SYSTEM

WARNING:

When replacing fuel line parts, be sure to observe the following:

- a. Put a "CAUTION: INFLAMMABLE" sign in workshop.
- b. Be sure to furnish the workshop with a CO₂ fire extinguisher.
- c. Be sure to disconnect battery ground cable before conducting operations.
- d. Put drained fuel in an explosion-proof container and attach lid securely.

CAUTION:

Before disconnecting fuel hose on gasoline engine model, release fuel pressure from fuel line. Refer to the "Releasing Fuel Pressure" in EF & EC section.

- a. Do not disconnect any fuel line unless absolutely necessary.
- b. Plug hose and pipe openings to prevent entry of dust or dirt.
- c. Always replace O-ring with new ones.
- d. Do not kink or twist hose and tube when they are installed.
- e. Do not tighten hose clamps excessively to avoid damaging hoses.
- f. When installing fuel check valve, be careful of its designated direction (Refer to section EF & EC).
- g. Run the engine and check for fuel leaks at connections.

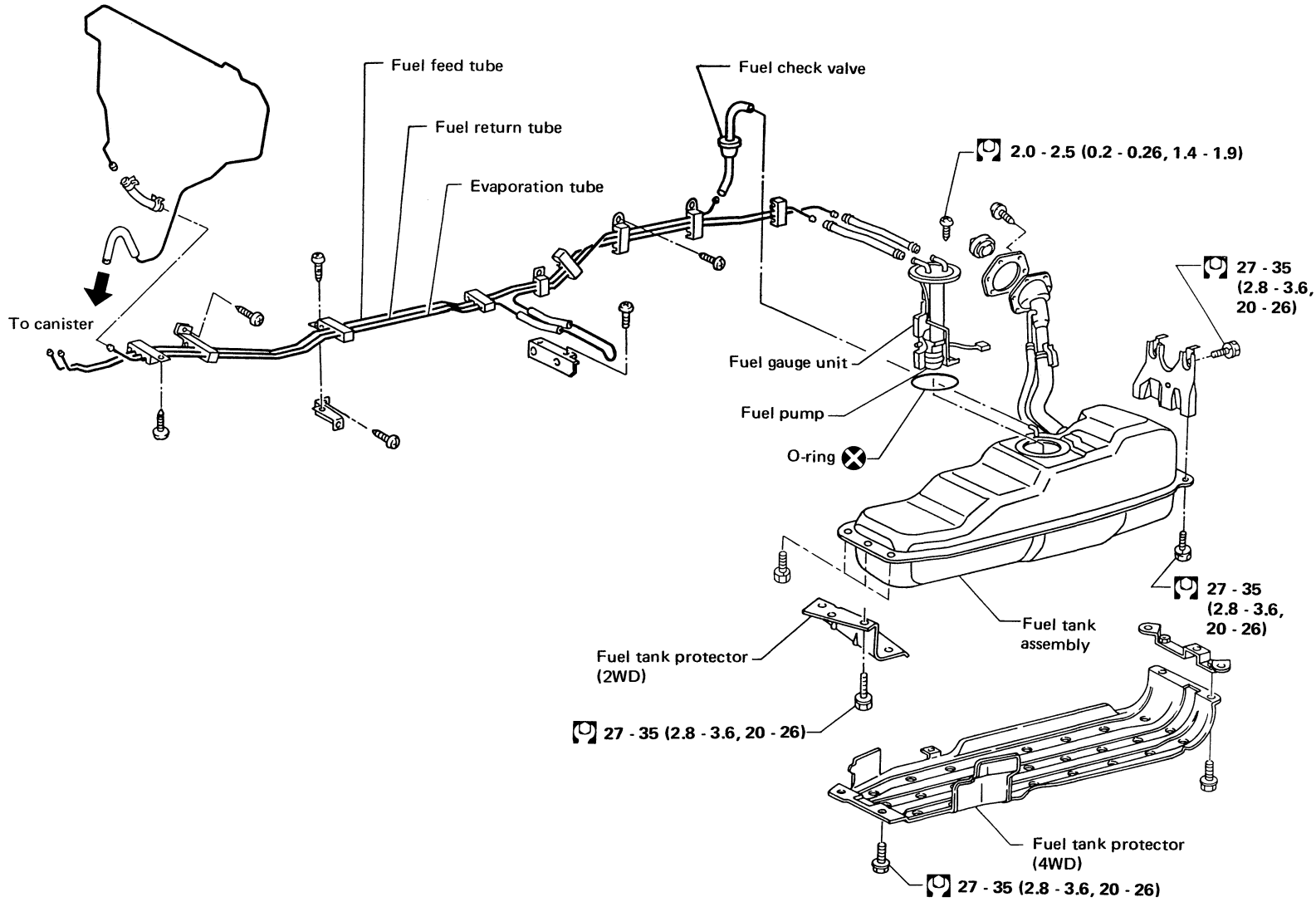

: N·m (kg·m, ft·lb)

FE-4

SFE002A

FUEL SYSTEM

Van and Wagon

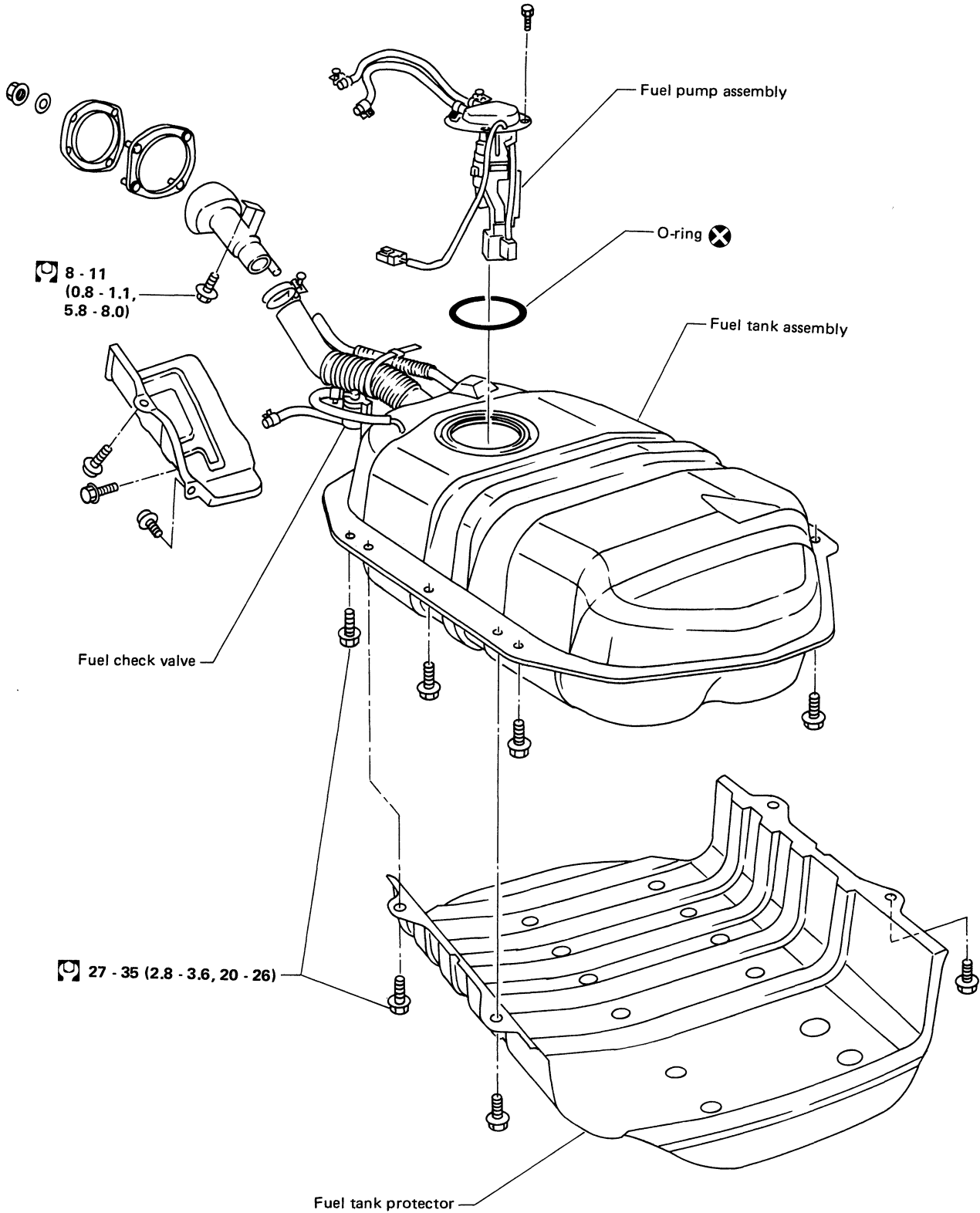

: N·m (kg·m, ft·lb)

SFE003A

FE-5

EXHAUST SYSTEM

CAUTION:

- a. Be careful not to drop or damage catalytic converter.
- b. Never wet catalytic converter with water, oil, etc.
- After installation, make sure that mounting brackets and mounting insulators are free from undue stress. If any of above parts is not installed properly, excessive noises or vibrations may be transmitted to vehicle body.
- Check all tube connections for exhaust gas leaks, and entire system for unusual noises, with engine running.

Z24i model (2WD) for Truck

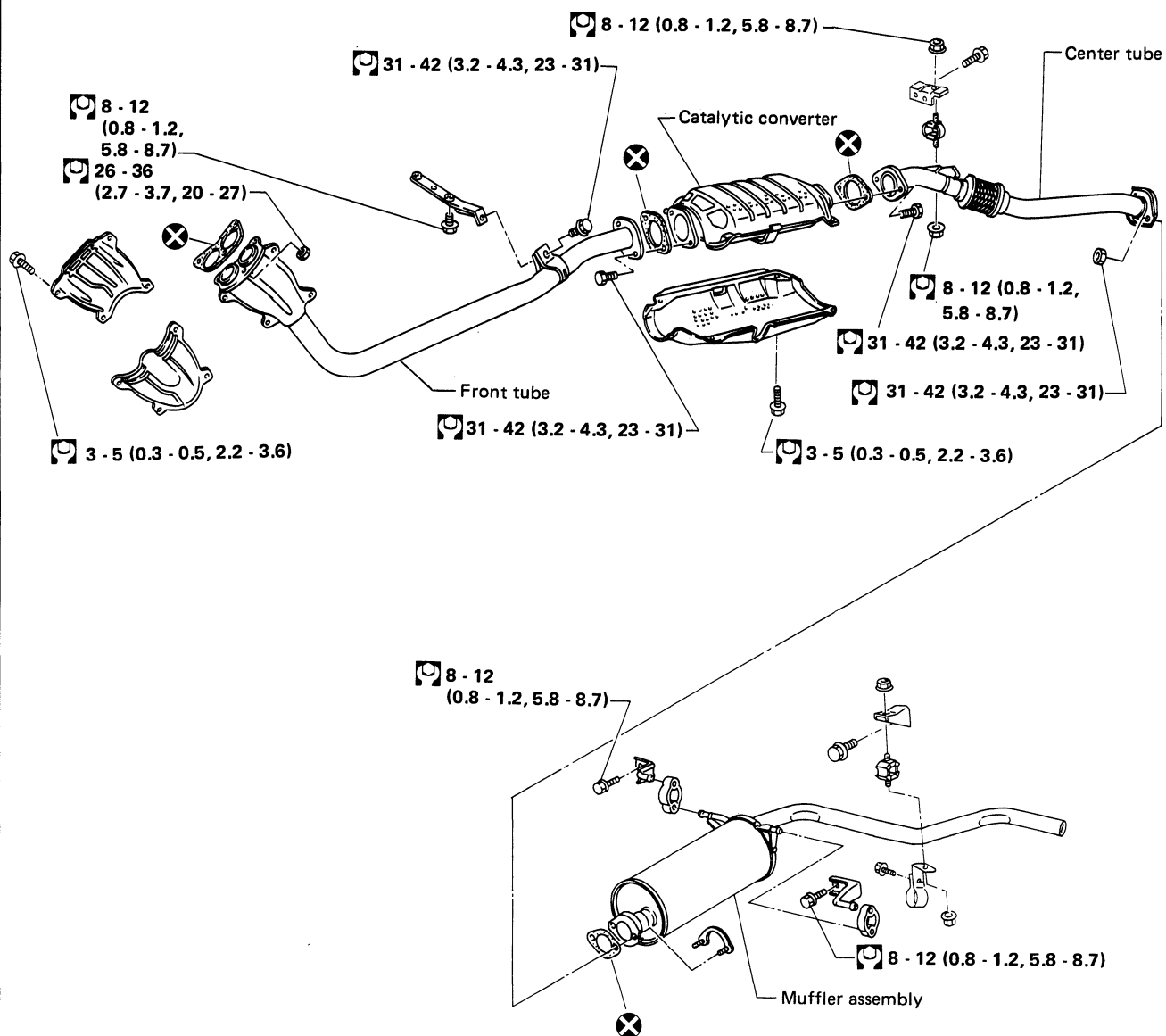

: N-m (kg-m, ft-lb)

SFE004A

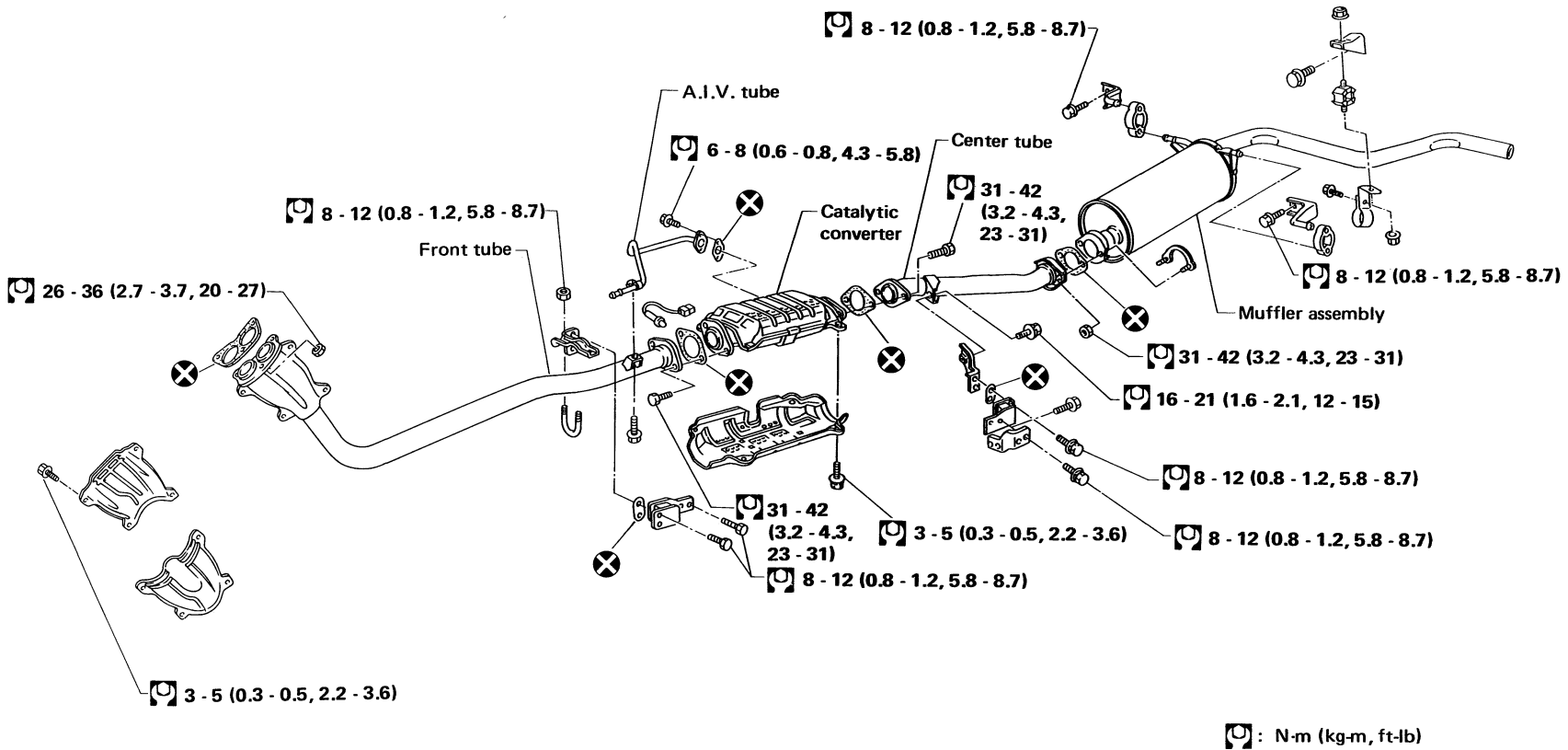

FE-7

VG30i model for Truck

4WD

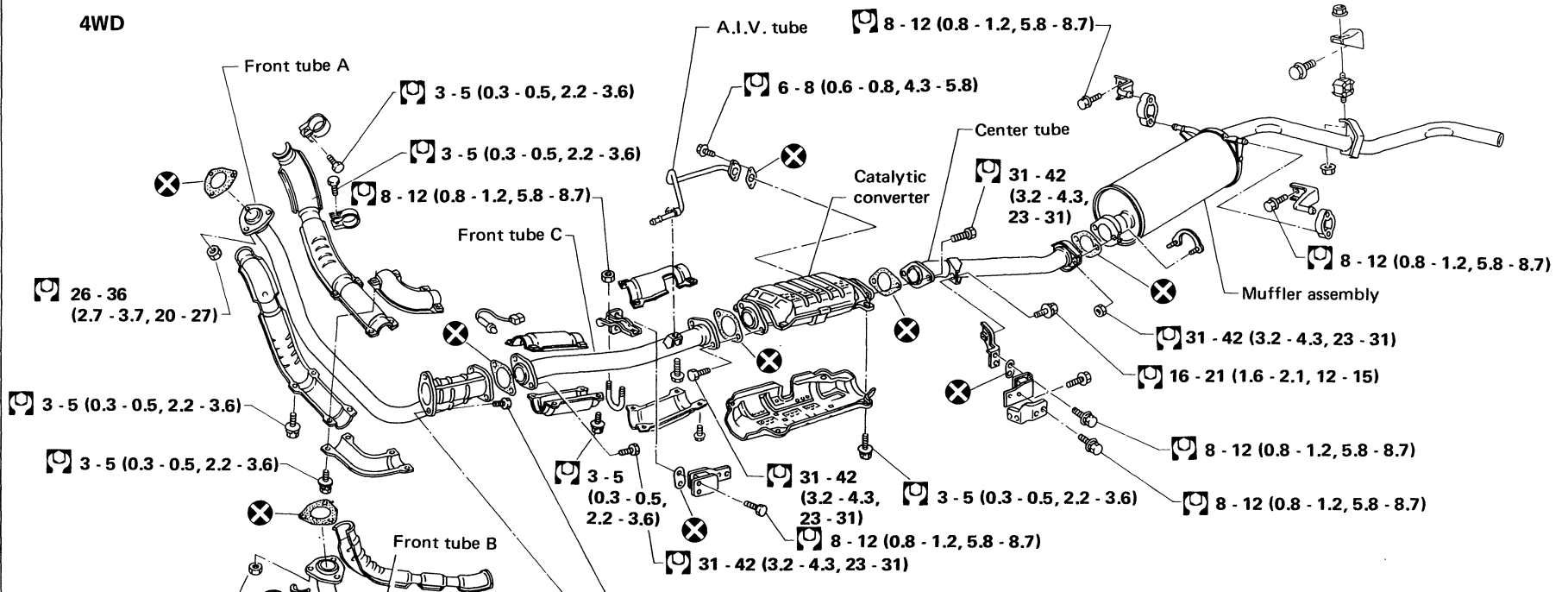

2WD

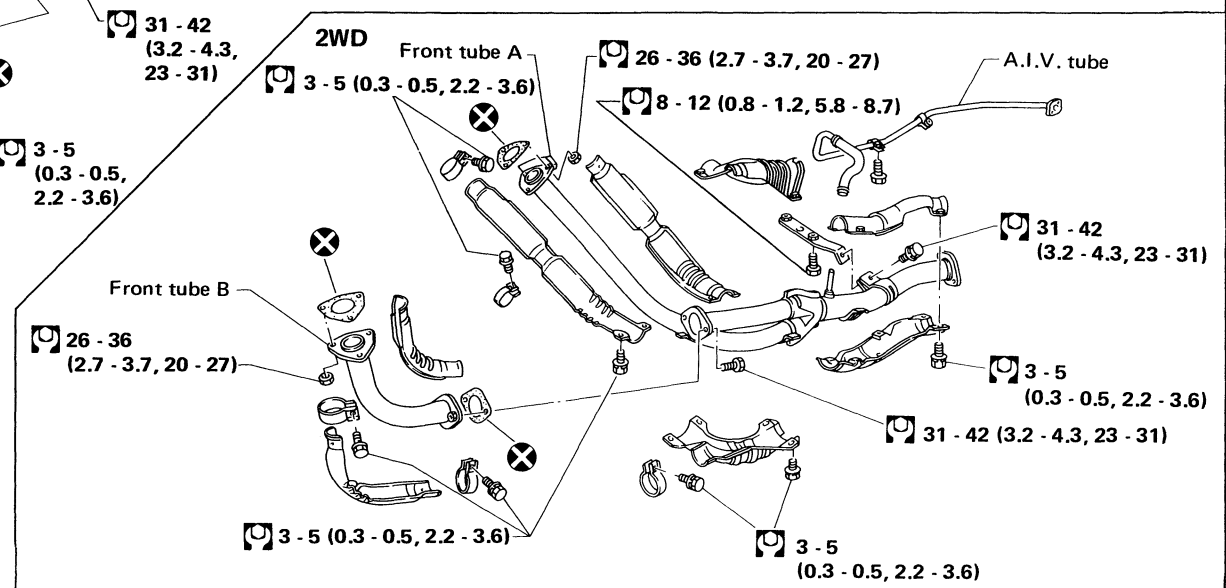

: N·m (kg·m, ft·lb)

FE-8

SFE006A

EXHAUST SYSTEM

EXHAUST SYSTEM

Z24i model for Van and Wagon

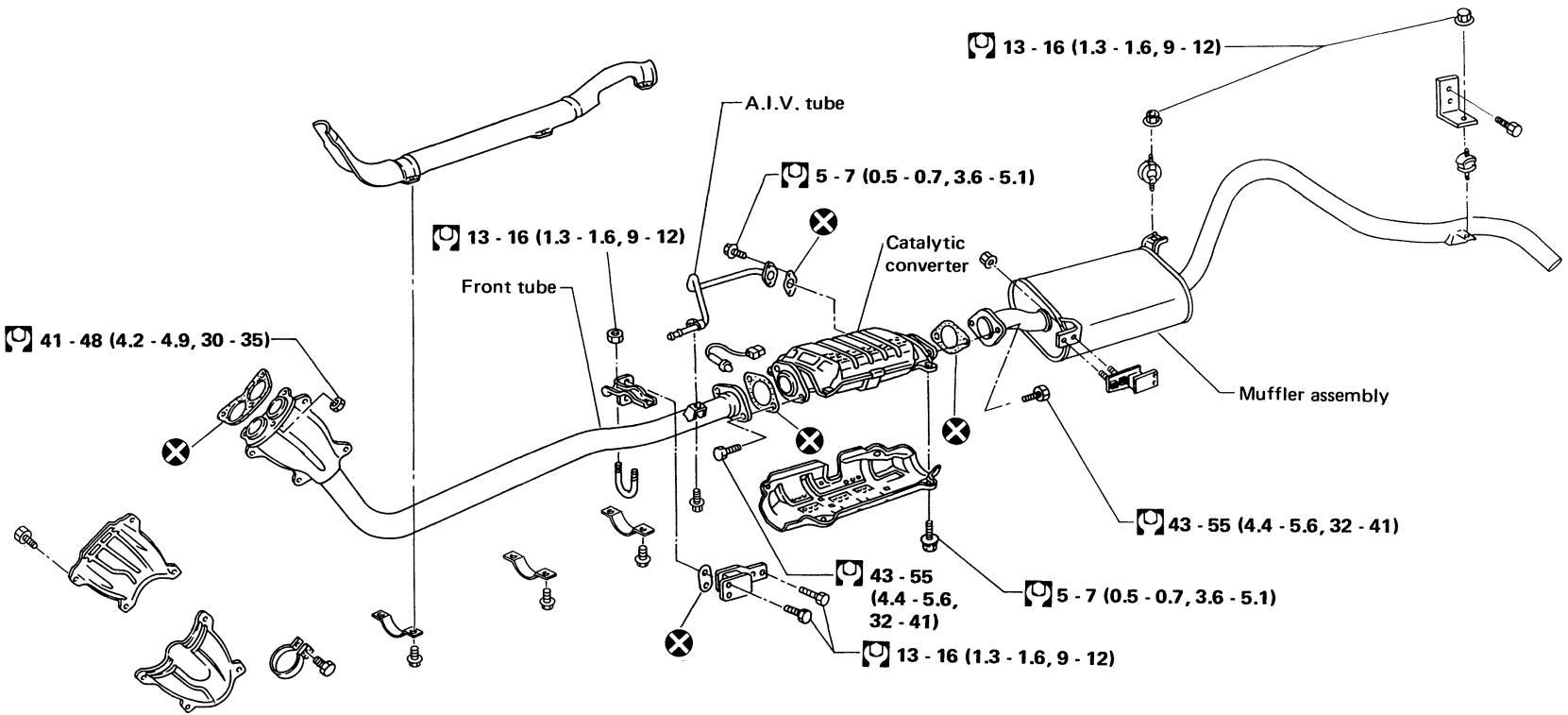

 : N-m (kg-m, ft-lb)

FE-9

SFE007A

EXHAUST SYSTEM

VG30i model for Van and Wagon

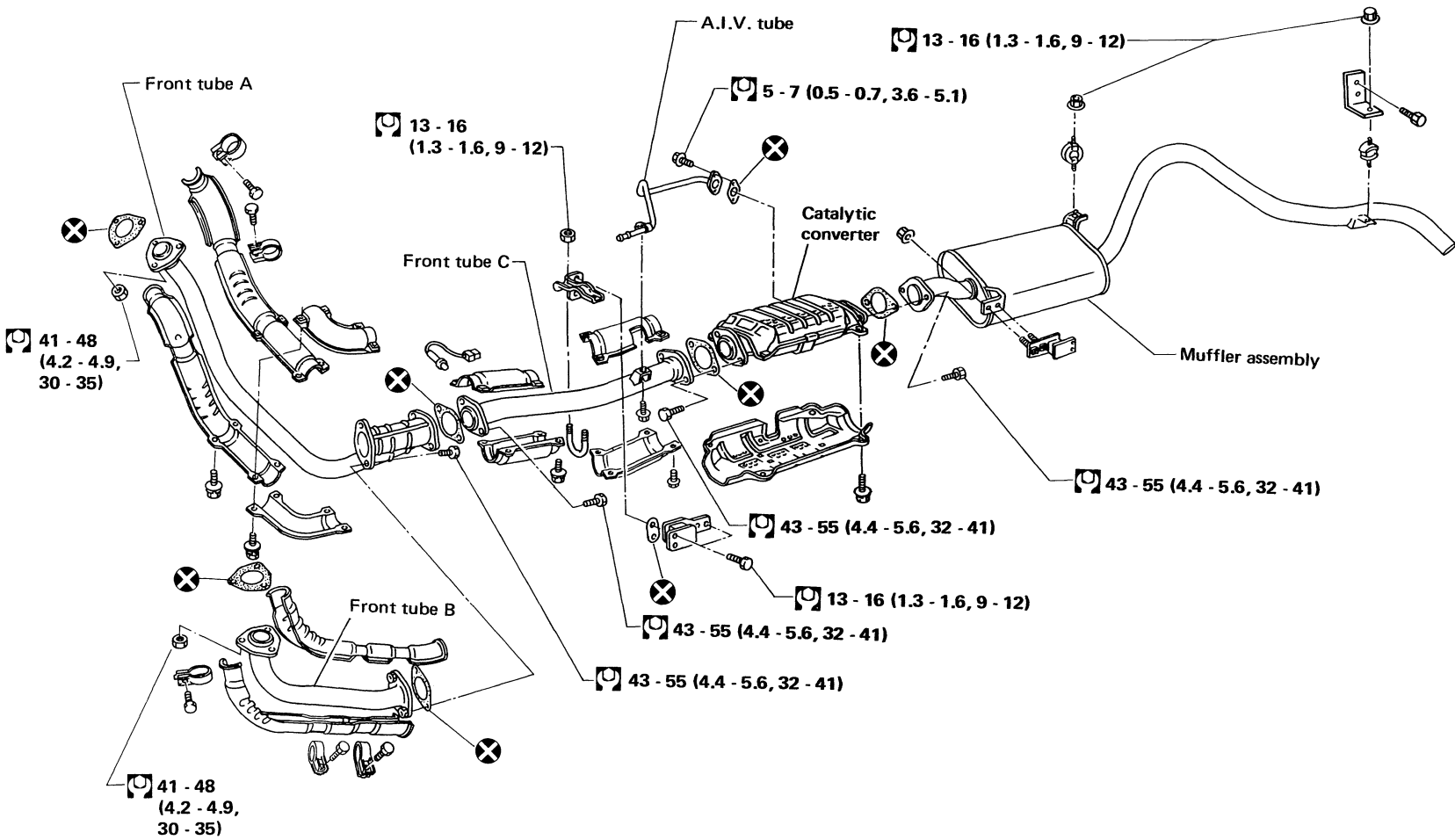

: N-m (kg-m, ft-lb)

FE-10

SFE008A

SECTION CL

CONTENTS

PRECAUTIONS CL- 2
PREPARATION CL- 3
CLUTCH SYSTEM CL- 4
INSPECTION AND ADJUSTMENT CL- 6
HYDRAULIC CLUTCH CONTROL CL- 8
CLUTCH RELEASE MECHANISM CL-11
CLUTCH DISC AND CLUTCH COVER CL-13
SERVICE DATA AND SPECIFICATIONS (S.D.S.) CL-15



PRECAUTIONS

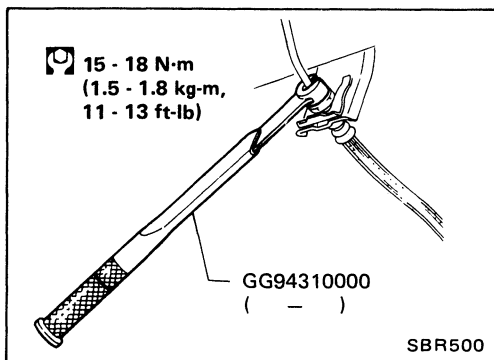





- Recommended fluid is brake fluid "DOT 3".
- Never reuse drained brake fluid.
- Be careful not to splash brake fluid on painted areas.
- When removing and installing clutch piping, use Tool.
- To clean or wash all parts of master cylinder, operating cylinder and clutch damper, use clean brake fluid.
- Never use mineral oils such as gasoline or kerosene.
It will ruin the rubber parts of the hydraulic system.

WARNING:

Remove all dust from clutch disc with a dust collector after cleaning with waste cloth.

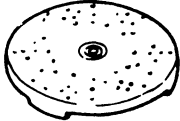
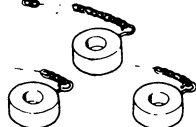
PREPARATION

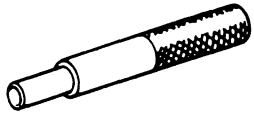
SPECIAL SERVICE TOOLS

Tool number (Kent-Moore No.) Tool name	Description	
ST20050010 (-) Base plate		Inspecting diaphragm spring of clutch cover
ST20050100 (-) Distance piece		
GG94310000 (-) Flare nut torque wrench		Removing and installing each clutch piping
ST20600000 (J26366) Clutch aligning bar		Installing clutch cover and clutch disc
ST20050240 (-) Diaphragm spring adjusting wrench		Adjusting unevenness of diaphragm spring of clutch cover

COMMERCIAL SERVICE TOOLS

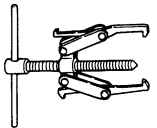
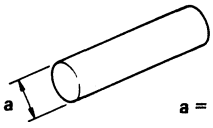
Tool name	Description	
Bearing puller		Removing release bearing
Bearing drift	 a = 50 mm (1.97 in) dia.	Installing release bearing

CLUTCH SYSTEM

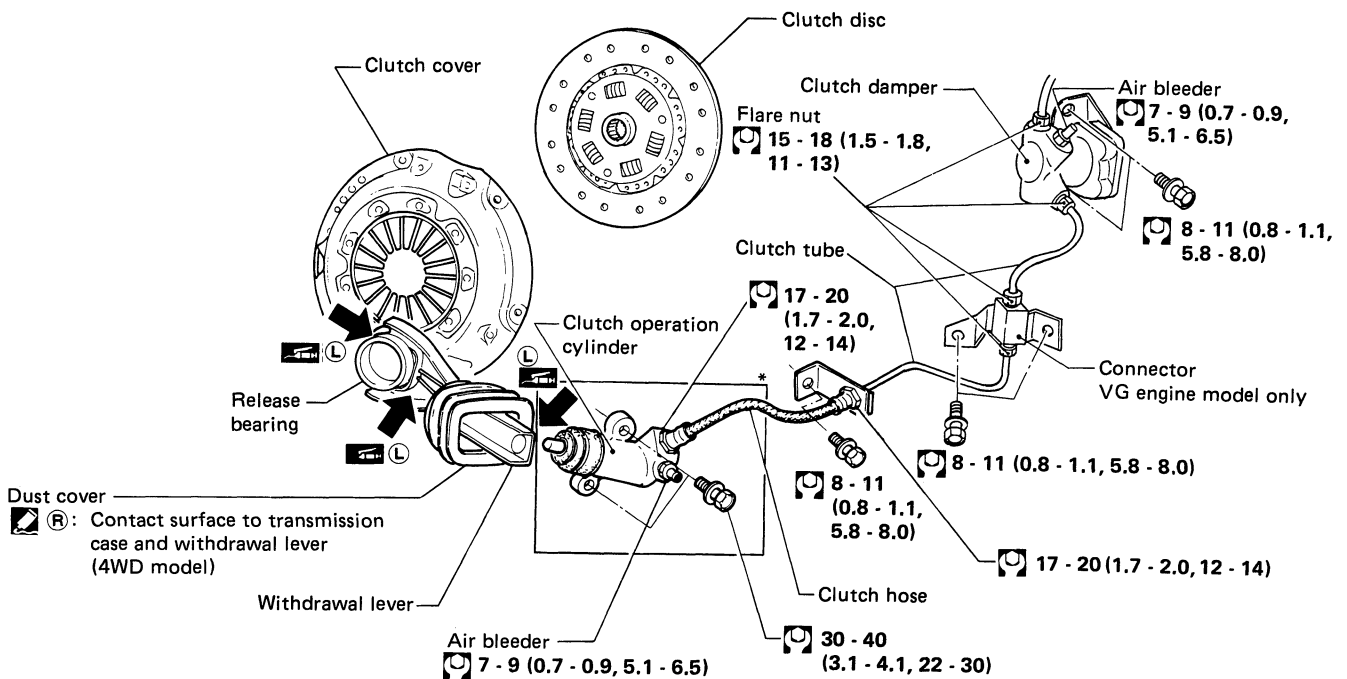
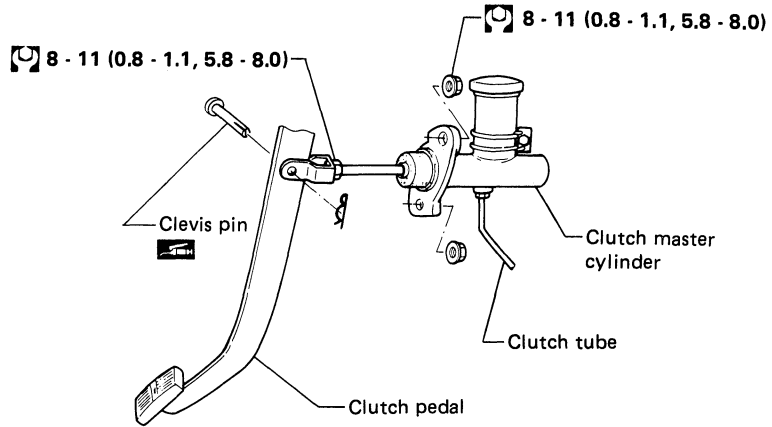

* VG engine 4WD model

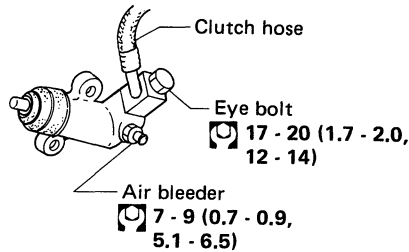

Z engine 4WD model

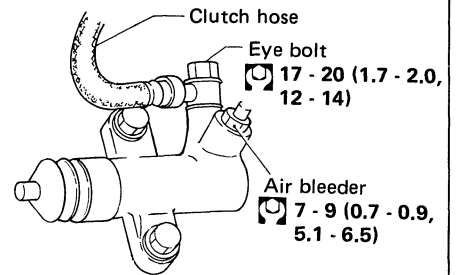

- ®** : Apply recommended sealant (Nissan genuine part: KP115-00100) or equivalent.
- L** : Apply lithium-based grease including molybdenum disulphide.
- : N-m (kg-m, ft-lb)

CLUTCH SYSTEM

Clutch Pedal

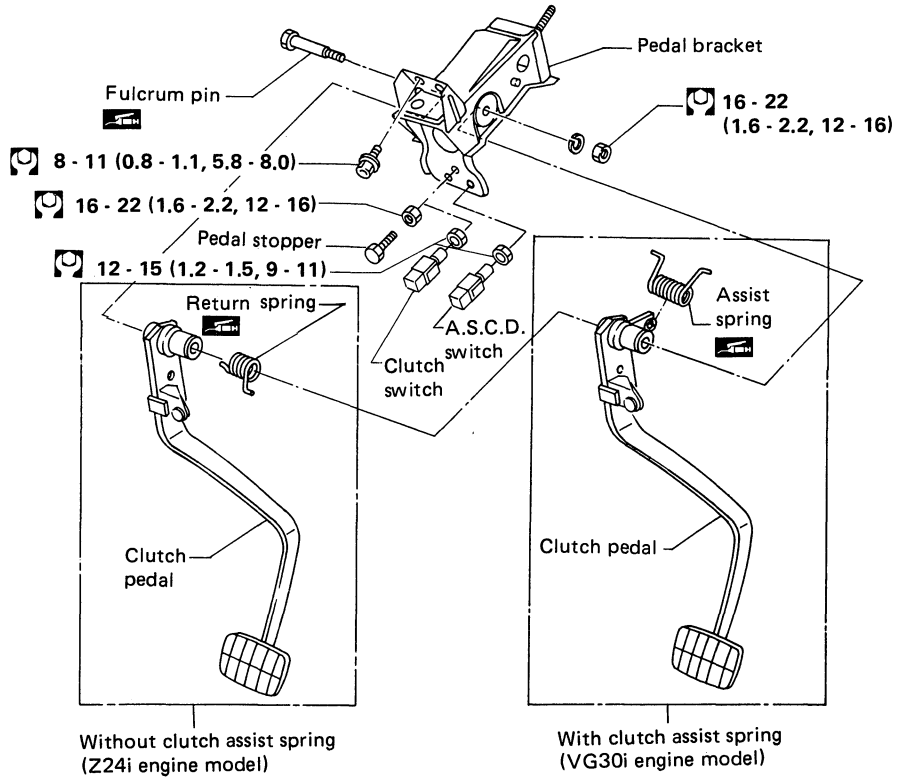

SCL282

Adjusting Clutch Pedal

1. Adjust pedal height with pedal stopper or clutch switch.
2. Adjust pedal free play with push rod.

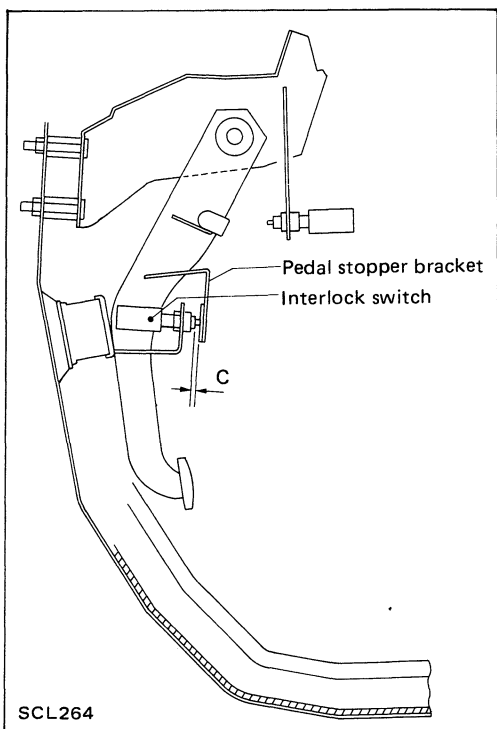
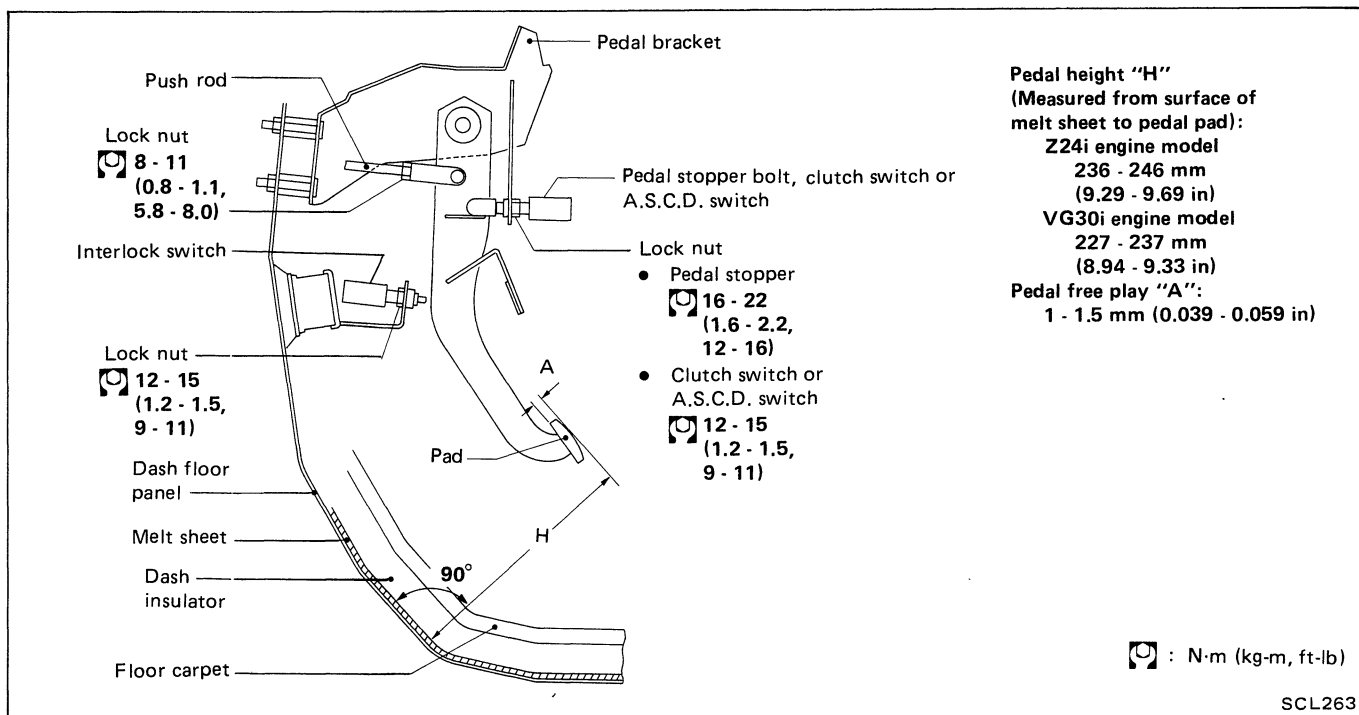

3. Adjust clearance "C" between pedal stopper bracket and threaded end of clutch interlock switch while depressing clutch pedal fully.

Clearance "C" between pedal stopper bracket and threaded end of clutch interlock switch (When depressing clutch pedal fully):
 0.3 - 1.0 mm (0.012 - 0.039 in)

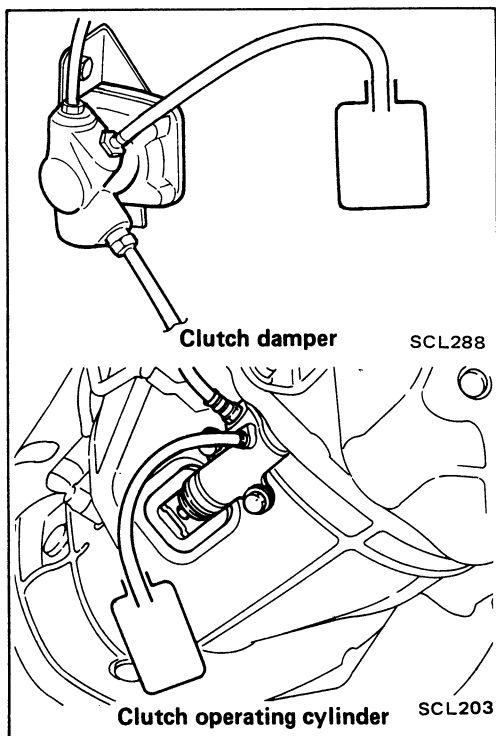

Bleeding Procedure

Bleed air according to the following procedure.

Clutch damper → Clutch operating cylinder

- Carefully monitor fluid level at master cylinder during bleeding operation.
1. Top up reservoir with recommended brake fluid.
 2. Connect a transparent vinyl tube to air bleeder valve.
 3. Fully depress clutch pedal several times.
 4. With clutch pedal depressed, open bleeder valve to release air.
 5. Close bleeder valve.
 6. Repeat steps 3 through 5 above until brake fluid comes out of air bleeder valve without air bubbles.

HYDRAULIC CLUTCH CONTROL

Clutch Master Cylinder

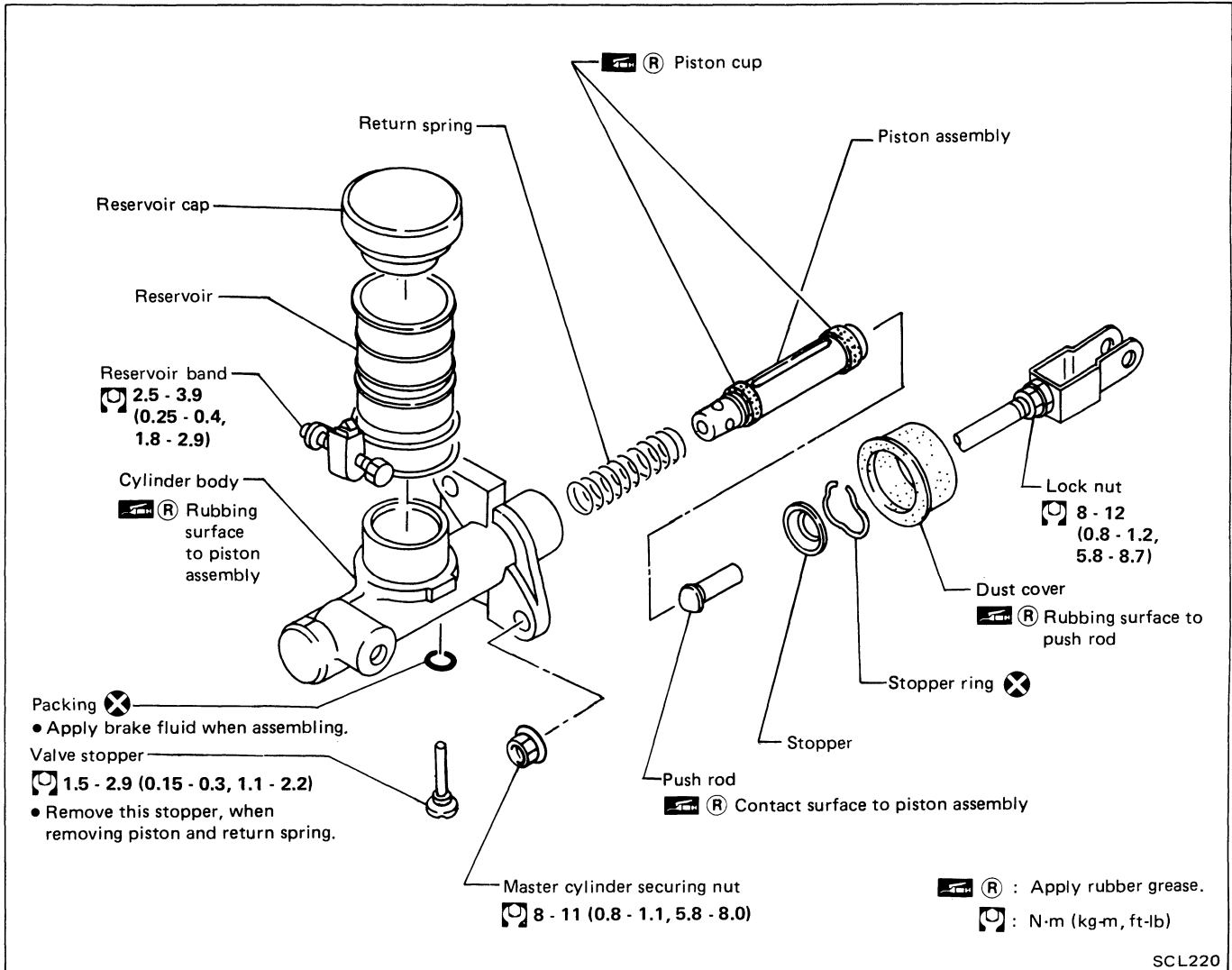

DISASSEMBLY AND ASSEMBLY

- Push piston in cylinder body with screwdriver when removing and installing valve stopper.

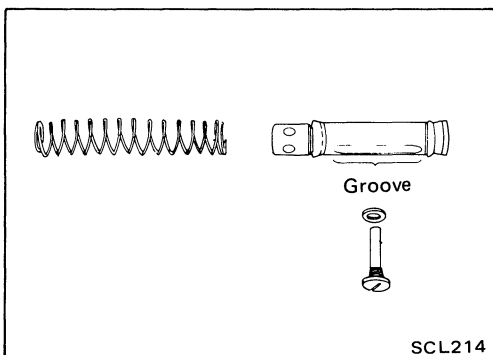

- Align groove of piston assembly and valve stopper portion when installing valve stopper.
- Check direction of piston caps.

HYDRAULIC CLUTCH CONTROL

Clutch Master Cylinder (Cont'd)

INSPECTION

- Check cylinder and piston rubbing surface for uneven wear, rust or damage. Replace if necessary.
- Check piston with piston cup for wear or damage. Replace if necessary.
- Check return spring for wear or damage. Replace if necessary.
- Check reservoir for deformation or damage. Replace if necessary.
- Check dust cover for cracks, deformation or damage. Replace if necessary.

Operating Cylinder

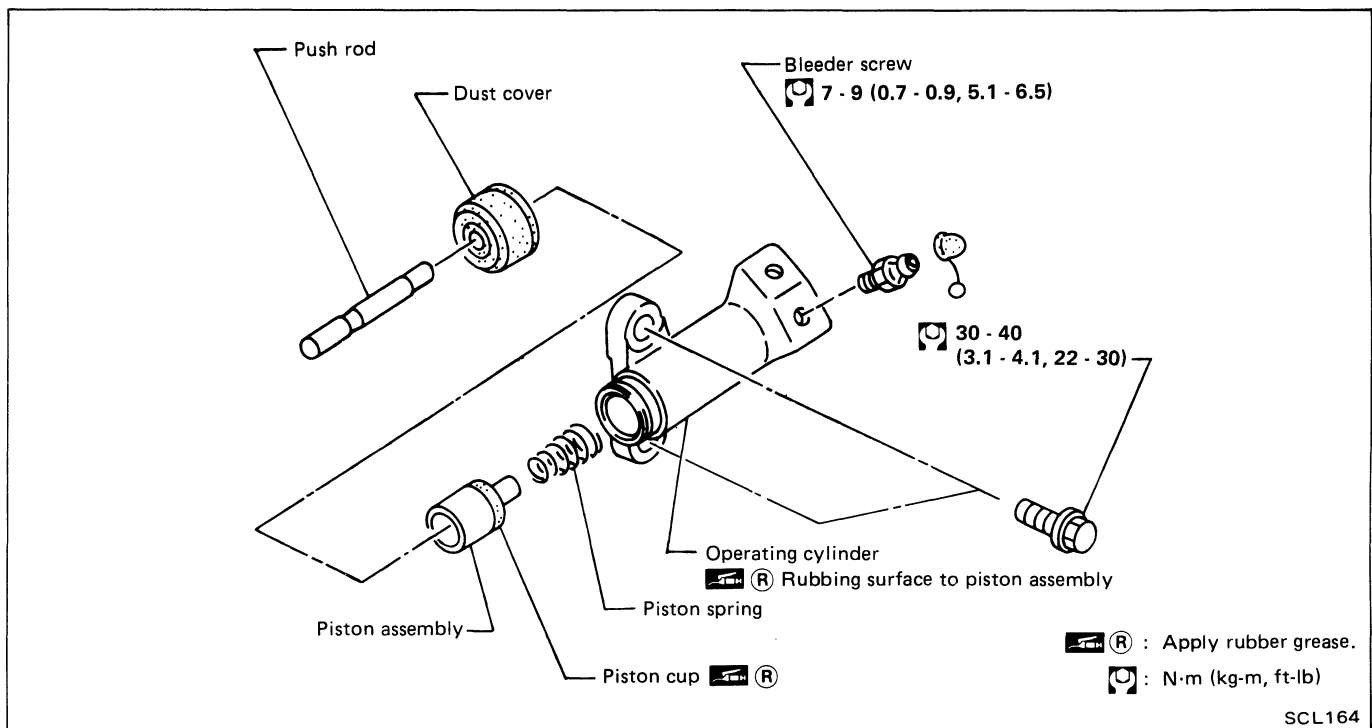

INSPECTION

- Check rubbing surface of cylinder for wear, rust or damage. Replace if necessary.
- Check piston with piston cup for wear or damage. Replace if necessary.
- Check piston spring for wear or damage. Replace if necessary.
- Check dust cover for cracks, deformation or damage. Replace if necessary.

Clutch Damper

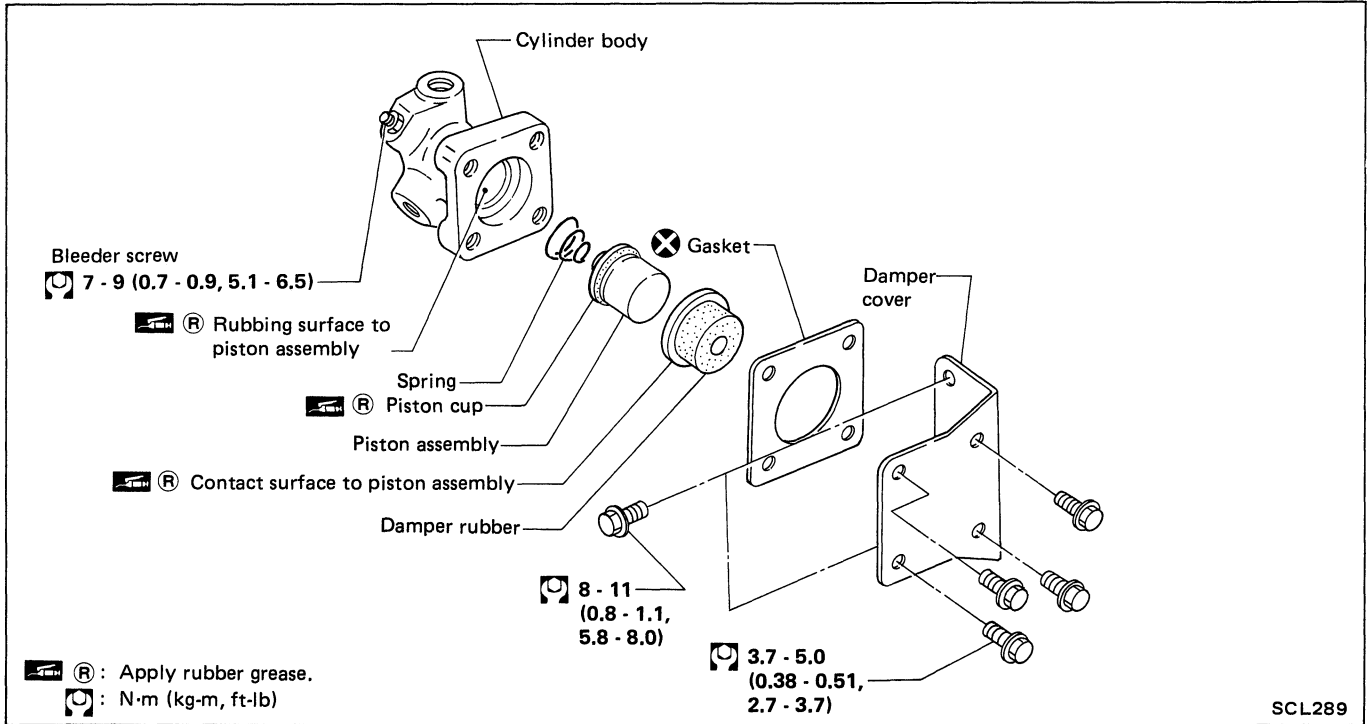

INSPECTION

- Check cylinder and piston rubbing surface for uneven wear, rust or damage. Replace if necessary.
- Check damper rubber and piston cup for cracks, deformation or damage. Replace if necessary.

CLUTCH RELEASE MECHANISM

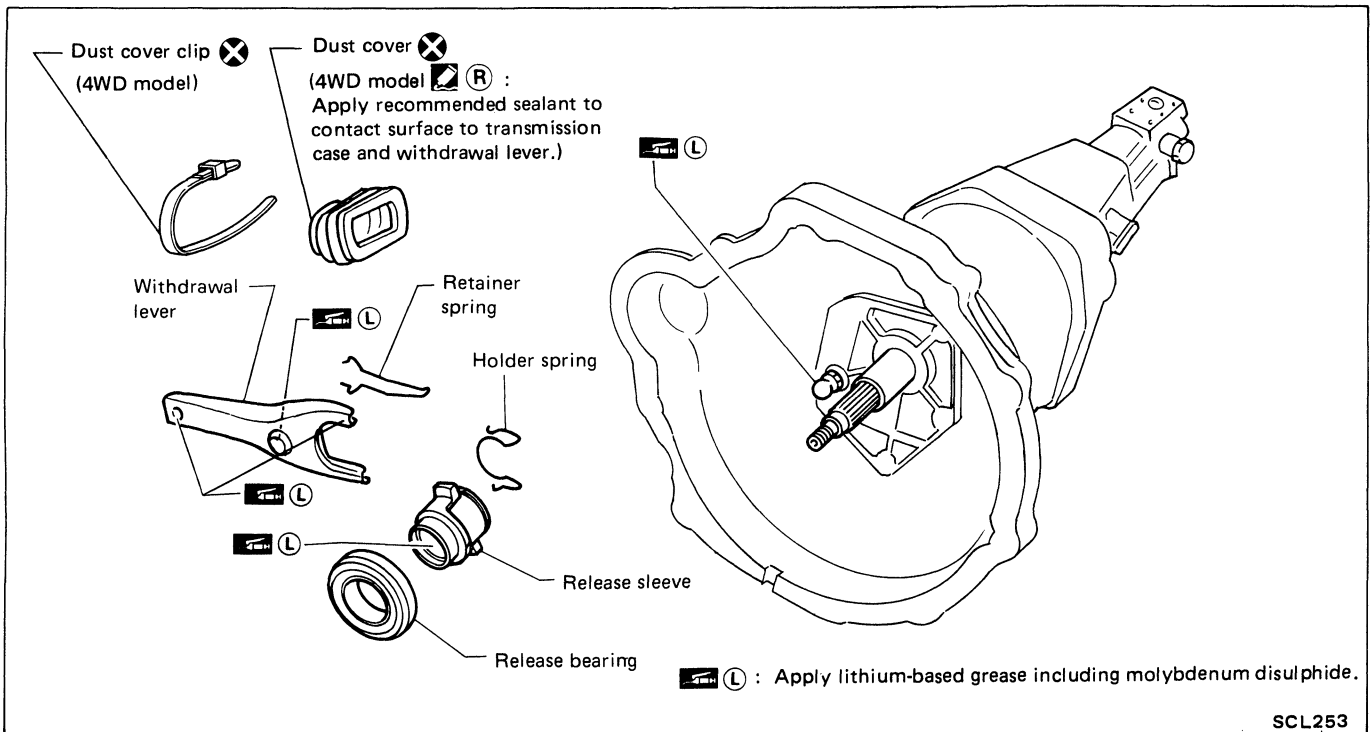

REMOVAL AND INSTALLATION

- Install retainer spring and holder spring.

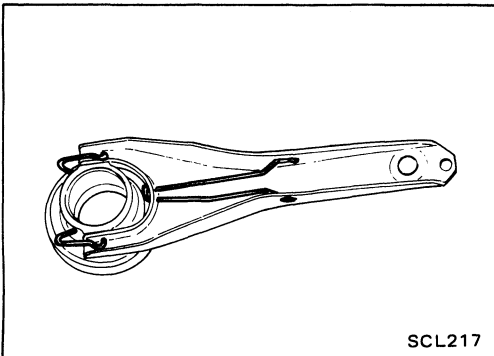

- Remove release bearing.

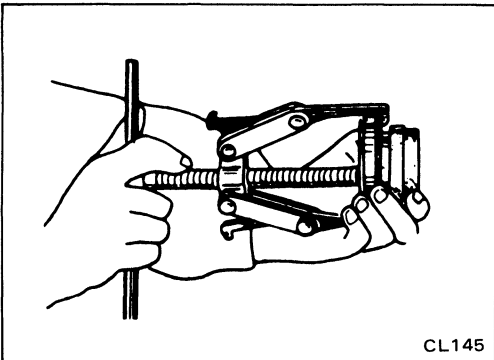

- Install release bearing with suitable drift.

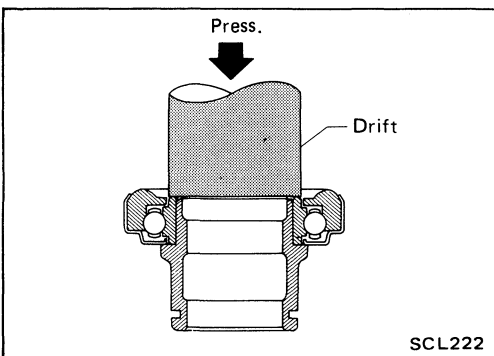

CLUTCH RELEASE MECHANISM

INSPECTION

- Check release bearing to see that it rolls freely and is free from noise, crack, pitting or wear. Replace if necessary.
- Check release sleeve and withdrawal lever rubbing surface for wear, rust or damage. Replace if necessary.

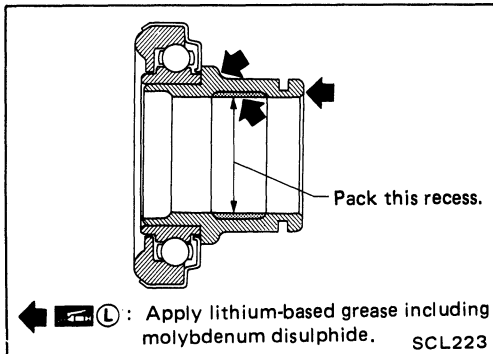

LUBRICATION

- Apply recommended grease to contact surface and rubbing surface.

Too much lubricant might cause clutch disc facing damage.

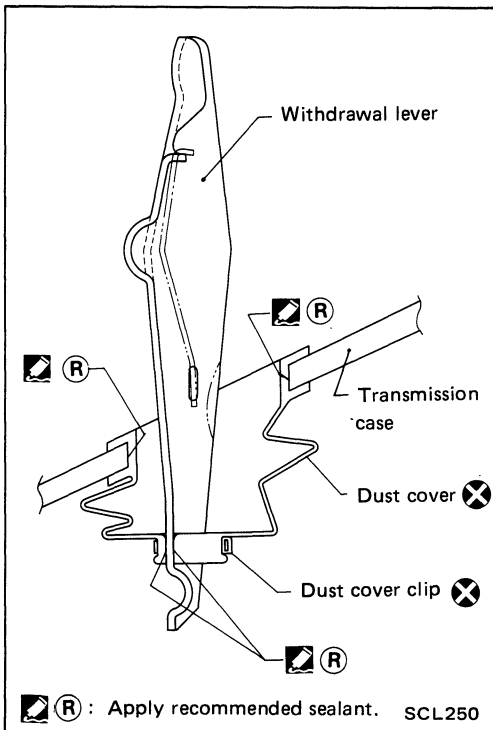

WATERPROOF – for 4WD model

- Apply recommended sealant to contact surface of dust cover to transmission case and withdrawal lever and then install dust cover clip.

Recommended sealant: Nissan genuine part (KP115-00100) or equivalent.

CLUTCH DISC AND CLUTCH COVER

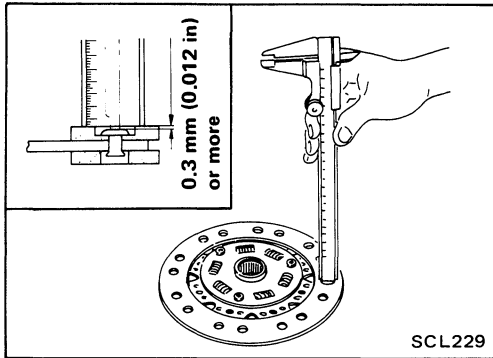
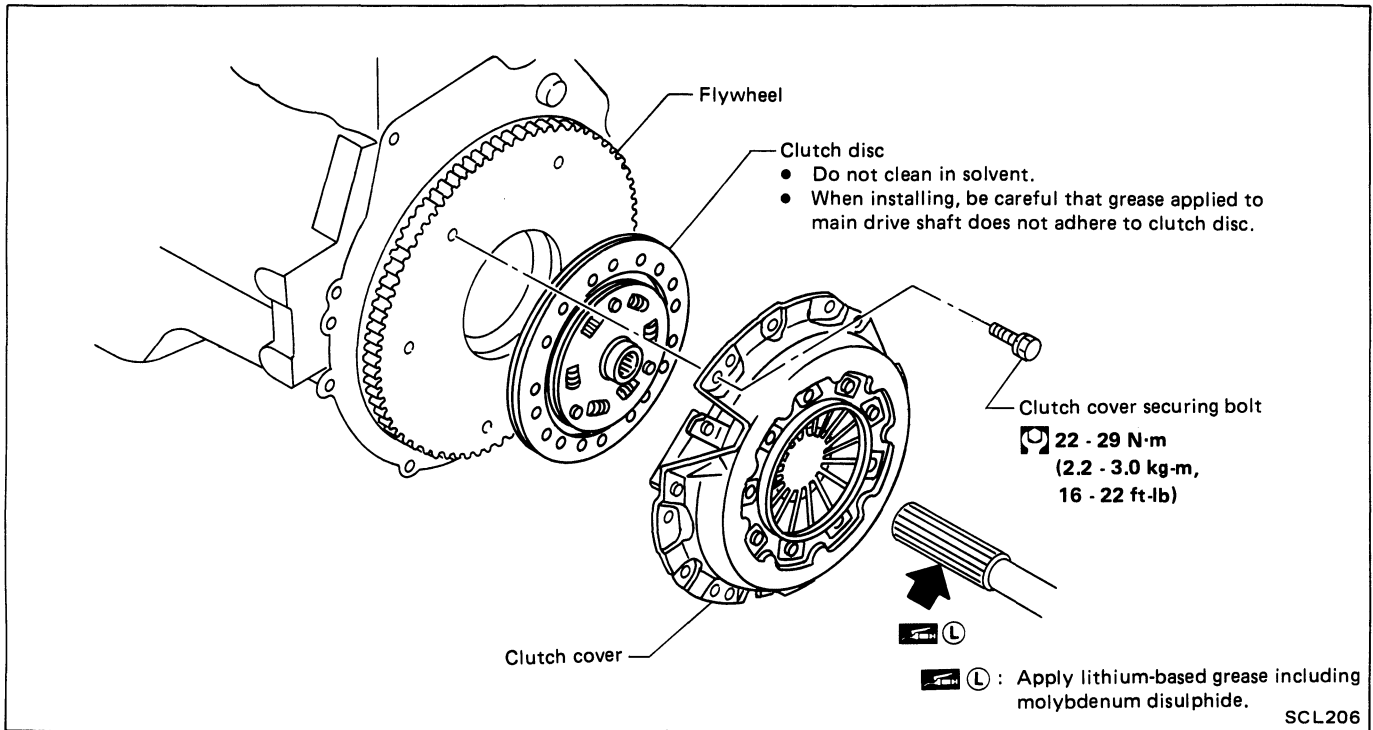

Clutch Disc

INSPECTION

Check clutch disc for wear of facing.

**Wear limit of facing surface to rivet head:
0.3 mm (0.012 in)**

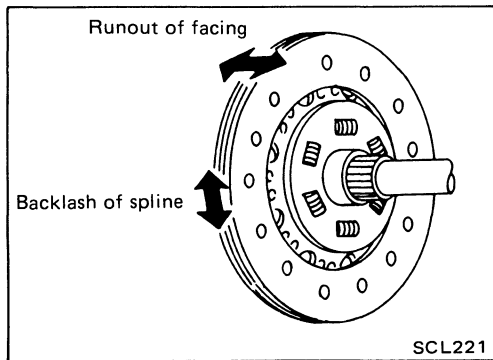

- Check clutch disc for backlash of spline and runout of facing.

Maximum backlash of spline (at outer edge of disc):

240TBL 1.0 mm (0.039 in)

250TBL 1.0 mm (0.039 in)

Runout limit:

1.0 mm (0.039 in)

Distance of runout check point (from hub center)

240TBL 115 mm (4.53 in)

250TBL 115 mm (4.53 in)

- Check clutch disc for burns, discoloration or oil or grease leakage. Replace if necessary.

INSTALLATION

- Apply recommended grease to contact surface of spline portion.

Too much lubricant might cause clutch disc facing damage.

CLUTCH DISC AND CLUTCH COVER

Clutch Cover and Flywheel

INSPECTION AND ADJUSTMENT

- Set Tool and check height and unevenness of diaphragm spring. Set 0.2 mm (0.008 in) feeler gauges on distance pieces (ST20050100) when checking C240S or C250S.

Diaphragm spring height "A":

C240S 37.5 - 39.5 mm (1.476 - 1.555 in)

C250S 36.5 - 38.5 mm (1.437 - 1.516 in)

- Check thrust rings for wear or damage by shaking cover assembly and listening for a chattering noise, or by lightly hammering on rivets and listening for a cracking noise. Replace clutch cover assembly if necessary.
- Check pressure plate and clutch disc contact surface for slight burns or discoloration. Repair pressure plate with emery paper.
- Check pressure plate and clutch disc contact surface for deformation or damage. Replace if necessary.

- Adjust unevenness of diaphragm spring height with Tool.

Uneven limit:

0.5 mm (0.020 in)

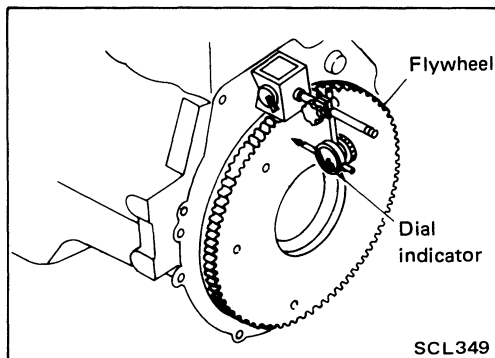
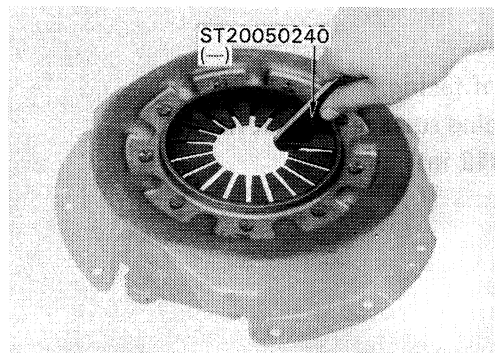
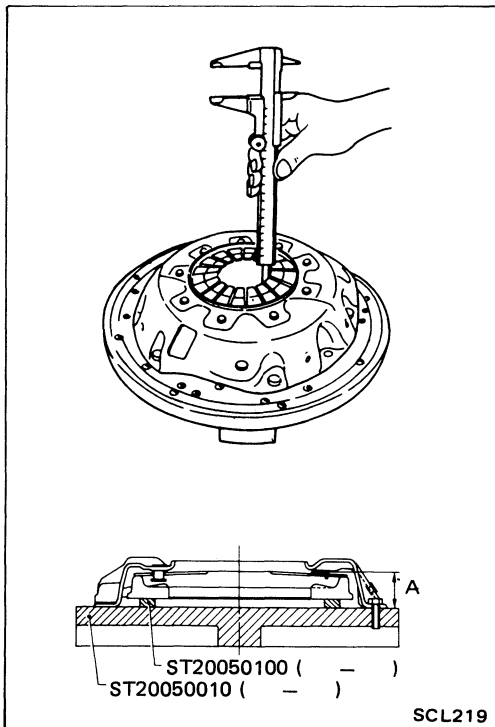

FLYWHEEL INSPECTION

- Check contact surface of flywheel for slight burns or discoloration. Repair flywheel with emery paper.
- Check flywheel runout.

Runout (Total indicator reading):

Less than 0.15 mm (0.0059 in)

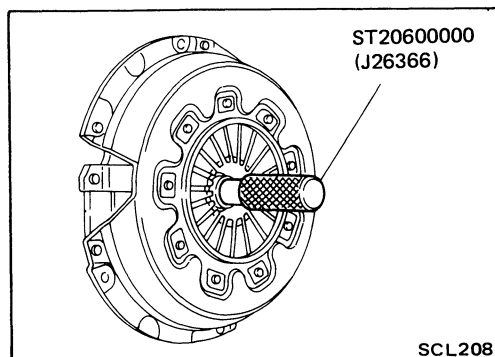

INSTALLATION

- Insert Tool into clutch disc hub when installing clutch cover and disc.

SERVICE DATA AND SPECIFICATIONS (S.D.S.)

General Specifications

CLUTCH MASTER CYLINDER

Inner diameter	mm (in)	15.87 (5/8)
----------------	---------	-------------

CLUTCH OPERATING CYLINDER

Inner diameter	mm (in)	17.46 (11/16)
----------------	---------	---------------

CLUTCH DAMPER

Inner diameter	mm (in)	19.05 (3/4)
----------------	---------	-------------

CLUTCH DISC

Model	240TBL	250TBL
Engine	Z24i	VG30i
Facing size (Outer dia. x inner dia. x thickness)	240 x 150 x 3.5 (9.45 x 5.91 x 0.138)	250 x 160 x 3.5 (9.84 x 6.30 x 0.138)
Thickness of disc assembly With load	7.8 - 8.2 (0.307 - 0.323) with 4,904 N (500 kg, 1,103 lb)	7.9 - 8.3 (0.311 - 0.327) with 5,884 N (600 kg, 1,323 lb)

CLUTCH COVER

Model	C240S	C250S
Engine	Z24i	VG30i
Full load	N (kg, lb) 3,923 (400, 882)	4,904 (500, 1,103)

Inspection and Adjustment

CLUTCH PEDAL

Unit: mm (in)

Pedal height "H*" Z24i engine model	236 - 246 (9.29 - 9.69)
VG30i engine model	227 - 237 (8.94 - 9.33)
Pedal free play	1 - 1.5 (0.039 - 0.059)
Clearance between pedal stopper bracket and threaded end of clutch interlock switch (when depressing clutch pedal fully.)	0.3 - 1.0 (0.012 - 0.039)

*: Measured from surface of melt sheet to pedal pad

CLUTCH DISC

Unit: mm (in)

Model	240TBL	250TBL
Wear limit of facing surface to rivet head	0.3 (0.012)	
Runout limit of facing	1.0 (0.039)	
Distance of runout check point (from the hub center)	115 (4.53)	
Maximum backlash of spline (at outer edge of disc)	1.0 (0.039)	

CLUTCH COVER

Unit: mm (in)

Model	C240S	C250S
Diaphragm spring height	37.5 - 39.5 (1.476 - 1.555)	36.5 - 38.5 (1.437 - 1.516)
Uneven limit of diaphragm spring toe height	0.5 (0.020)	

SERVICE DATA AND SPECIFICATIONS (S.D.S.)

Tightening Torque

Unit	N-m	kg-m	ft-lb
Pedal stopper lock nut	16 - 22	1.6 - 2.2	12 - 16
Clutch switch lock nut	12 - 15	1.2 - 1.5	9 - 11
A.S.C.D. switch lock nut	12 - 15	1.2 - 1.5	9 - 11
Interlock switch lock nut	12 - 15	1.2 - 1.5	9 - 11
Fulcrum pin securing nut	16 - 22	1.6 - 2.2	12 - 16
Clutch pedal bracket securing nut and bolt	8 - 11	0.8 - 1.1	5.8 - 8.0
Master cylinder push rod lock nut	8 - 11	0.8 - 1.1	5.8 - 8.0
Master cylinder securing nut	8 - 11	0.8 - 1.1	5.8 - 8.0
Valve stopper	1.5 - 2.9	0.15 - 0.3	1.1 - 2.2
Reservoir band	2.5 - 3.9	0.25 - 0.4	1.8 - 2.9
Operating cylinder securing bolt	30 - 40	3.1 - 4.1	22 - 30
Damper cover to cylinder body	3.7 - 5.0	0.38 - 0.51	2.7 - 3.7
Clutch tube flare nut	15 - 18	1.5 - 1.8	11 - 13
Bleeder screw	7 - 9	0.7 - 0.9	5.1 - 6.5
Clutch hose to operating cylinder or clutch tube	17 - 20	1.7 - 2.0	12 - 14
Clutch hose eye bolt	17 - 20	1.7 - 2.0	12 - 14
Clutch hose cramp to body	8 - 11	0.8 - 1.1	5.8 - 8.0
Clutch cover securing bolt	22 - 29	2.2 - 3.0	16 - 22

MANUAL TRANSMISSION

SECTION **MT**

CONTENTS

Models FS5W71C, F4W71C & FS5R30A	
PREPARATION	MT- 2
ON-VEHICLE SERVICE	MT- 6
REMOVAL AND INSTALLATION	MT- 7
Models FS5W71C & F4W71C	
MAJOR OVERHAUL	MT-10
DISASSEMBLY	MT-15
INSPECTION	MT-20
ASSEMBLY	MT-22
Model FS5R30A	
MAJOR OVERHAUL	MT-33
DISASSEMBLY	MT-37
INSPECTION	MT-44
ASSEMBLY	MT-46
Models FS5W71C, F4W71C & FS5R30A	
SERVICE DATA AND SPECIFICATIONS (S.D.S.)	MT-58

MT

PREPARATION

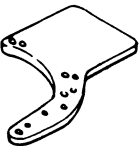
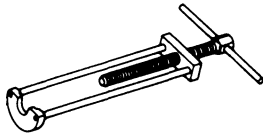
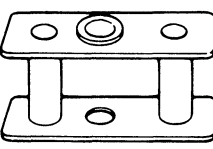
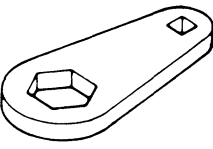
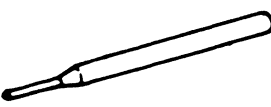
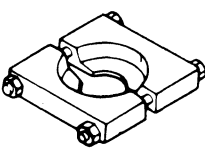
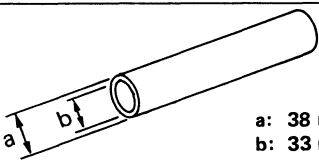
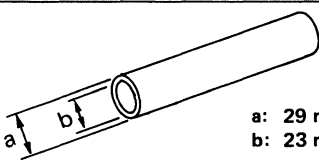
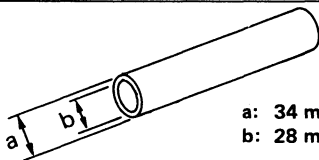
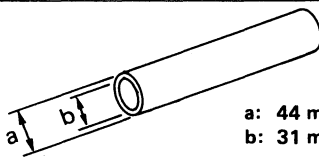

71C type

SPECIAL SERVICE TOOLS – for FS5W71C & F4W71C

Tool number (Kent-Moore No.) Tool name	Description	
ST23810001 (-) Adapter setting plate		Fixing adapter plate with gear assembly
KV32101330 (See J26349-A) Puller		Removing overdrive mainshaft bearing
KV31100401 (-) Transmission press stand		Pressing counter gear and mainshaft
ST22520000 (J26348) Wrench		Tightening mainshaft lock nut
ST23540000 (J25689-A) Pin punch		Removing and installing fork rod retaining pin
ST30031000 (J22912-01) Puller		Removing and installing 1st gear bushing Removing main drive gear bearing
ST23860000 (-) Drift	 a: 38 mm (1.50 in) dia. b: 33 mm (1.30 in) dia.	Installing counter drive gear
ST22360002 (J25679-01) Drift	 a: 29 mm (1.14 in) dia. b: 23 mm (0.91 in) dia.	Installing counter gear front and rear end bearings
ST22350000 (J25678-01) Drift	 a: 34 mm (1.34 in) dia. b: 28 mm (1.10 in) dia.	Installing O.D. gear bushing (FS5W71C)
ST23800000 (J25691-01) Drift	 a: 44 mm (1.73 in) dia. b: 31 mm (1.22 in) dia.	Installing front cover oil seal

PREPARATION

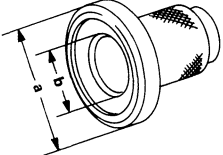

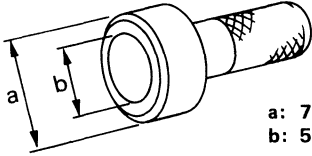
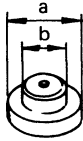
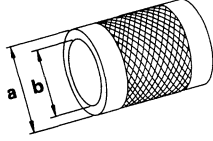
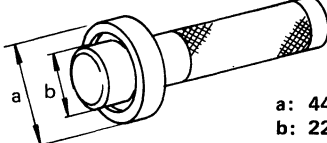
71C type

Tool number (Kent-Moore No.) Tool name	Description	
ST33400001 (J26082) Drift		Installing rear oil seal a: 60 mm (2.36 in) dia. b: 47 mm (1.85 in) dia.
ST33290001 (J25810-A) Puller		Removing rear oil seal
ST30720000 (-) Drift		Installing mainshaft ball bearing a: 77 mm (3.03 in) dia. b: 55.5 mm (2.185 in) dia.
ST30613000 (J25742-3) Drift		Installing main drive gear bearing a: 71.5 mm (2.815 in) dia. b: 47.5 mm (1.870 in) dia.
ST33200000 (J26082) Drift		Installing counter rear bearing a: 60 mm (2.36 in) dia. b: 44.5 mm (1.752 in) dia.
ST33220000 (-) Drift		Installing counter shaft rear end bearing (F4W71C) a: 44 mm (1.73 in) dia. b: 22 mm (0.87 in) dia.

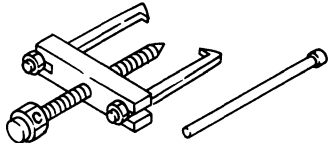
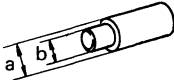
COMMERCIAL SERVICE TOOLS – for FS5W71C & F4W71C

Tool name	Description	
Puller		Removing counter bearings, counter drive and O.D. gears
Drift		Installing countershaft rear end bearing (FS5W71C-4WD model) a: 40 mm (1.57 in) dia. b: 30 mm (1.18 in) dia.

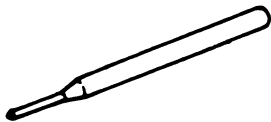
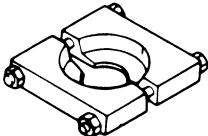
SPECIAL SERVICE TOOLS – for FS5R30A

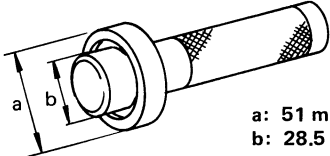
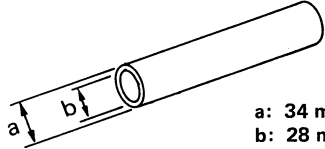
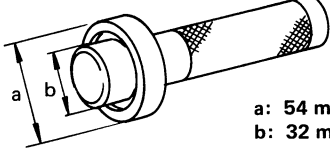
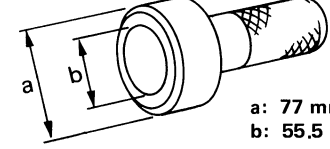
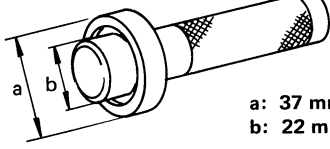
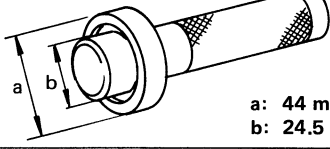
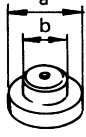
Tool number (Kent-Moore No.) Tool name	Description
ST23540000 (J25689-A) Pin punch	 <p>Removing and installing retaining pin</p>
ST30031000 (J22912-01) Puller	 <p>Removing 1st & 2nd synchronizer assembly Removing counter gear rear thrust bearing Removing main drive bearing</p>
ST33290001 (J25810-A) Puller	 <p>Removing rear oil seal</p>
ST33230000 (-) Drift	 <p>a: 51 mm (2.01 in) dia. b: 28.5 mm (1.122 in) dia.</p> <p>Removing mainshaft and counter gear</p>
ST22350000 (J25678-01) Drift	 <p>a: 34 mm (1.34 in) dia. b: 28 mm (1.10 in) dia.</p> <p>Removing counter gear front bearing (Use with KV38100300)</p>
KV38100300 (J25523) Drift	 <p>a: 54 mm (2.13 in) dia. b: 32 mm (1.26 in) dia.</p> <p>Removing counter gear front bearing (Use with ST22350000) Installing counter gear rear bearing</p>
ST30720000 ① (J34286) ② (J34331) Drift	 <p>a: 77 mm (3.03 in) dia. b: 55.5 mm (2.185 in) dia.</p> <p>① Removing mainshaft front bearing ② Installing mainshaft front bearing</p>
ST33220000 (J25804-01) Drift	 <p>a: 37 mm (1.46 in) dia. b: 22 mm (0.87 in) dia.</p> <p>Removing and installing counter gear rear end bearing (4WD model)</p>
ST33210000 ① (J25523) ② (J25803-01) Drift	 <p>a: 44 mm (1.73 in) dia. b: 24.5 mm (0.965 in) dia.</p> <p>① Installing counter gear front bearing ② Installing front cover oil seal</p>
ST30613000 (J25742-3) Drift	 <p>a: 72 mm (2.83 in) dia. b: 48 mm (1.89 in) dia.</p> <p>Installing main drive gear bearing</p>

PREPARATION

FS5R30A

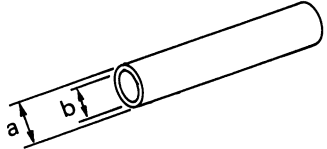
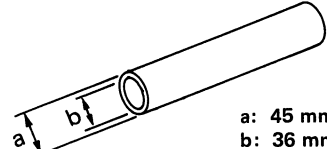
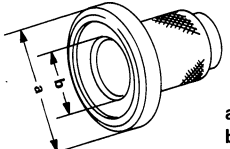
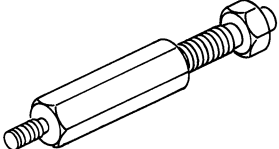
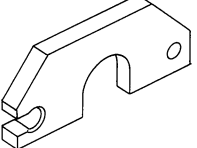
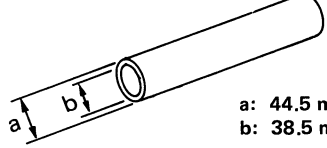
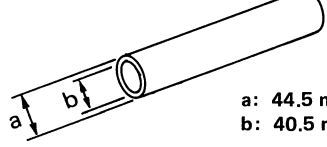
Tool number (Kent-Moore No.) Tool name	Description	
ST37750000 ① (J34286) ② (J34332) ③ (J34334) ④ (J25679-01) Drift	 <p style="text-align: center;">a: 40 mm (1.57 in) dia. b: 31 mm (1.22 in) dia.</p>	① Removing counter gear rear bearing ② Installing O.D. gear bushing ② Installing reverse cone ③ Installing reverse counter gear ④ Installing counter gear rear end bearing
ST22452000 (J34337) Drift	 <p style="text-align: center;">a: 45 mm (1.77 in) dia. b: 36 mm (1.42 in) dia.</p>	Installing reverse hub Installing mainshaft rear bearing (2WD model)
ST33400001 (J26082) Drift	 <p style="text-align: center;">a: 60 mm (2.36 in) dia. b: 47 mm (1.85 in) dia.</p>	Installing rear oil seal
(J26349-3) Puller leg		Installing mainshaft and counter gear (Use with J34328)
(J34328) Puller		Installing mainshaft and counter gear (Use with J26349-3)
(J26092) Drift	 <p style="text-align: center;">a: 44.5 mm (1.752 in) dia. b: 38.5 mm (1.516 in) dia.</p>	Installing sub-gear snap ring
(J34342) Drift	 <p style="text-align: center;">a: 44.5 mm (1.752 in) dia. b: 40.5 mm (1.594 in) dia.</p>	Installing O.D. main gear Installing reverse gear bushing

COMMERCIAL SERVICE TOOL – FS5R30A

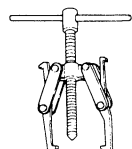
Tool name	Description	
Puller		Removing counter gear rear end bearing Removing mainshaft rear bearing (2WD model) Removing reverse synchronizer hub Removing reverse counter gear

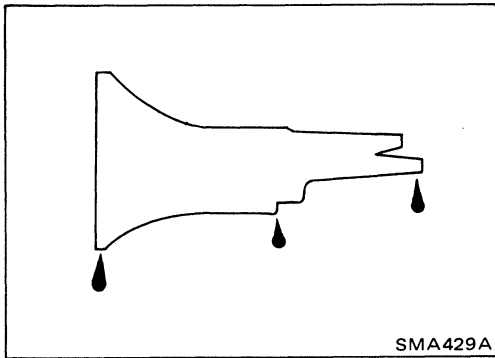

Checking M/T Oil

- Check manual transmission for oil leakage.

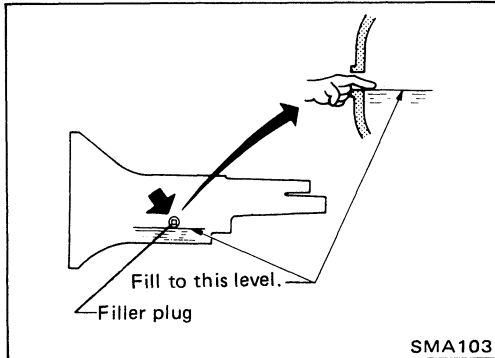

- Check oil level.

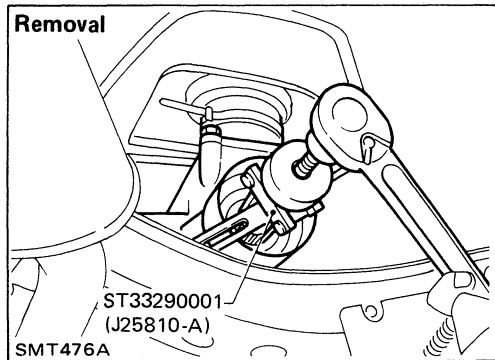

Replacing Rear Oil Seal — 2WD Model

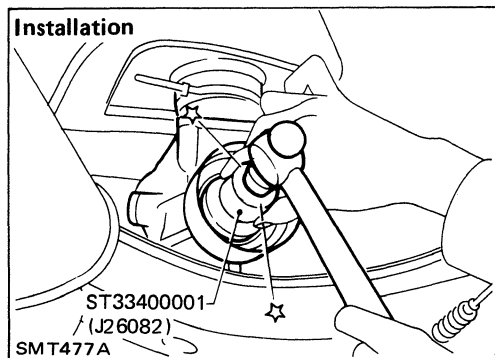

Removal — 2WD Model

- Remove propeller shaft. — Refer to section PD.
- Insert plug into rear oil seal after removing propeller shaft.

CAUTION:

Be careful not to damage spline, sleeve yoke and rear oil seal, when removing propeller shaft.

- Remove exhaust front tube A. (VG30i engine model) — Refer to section FE.

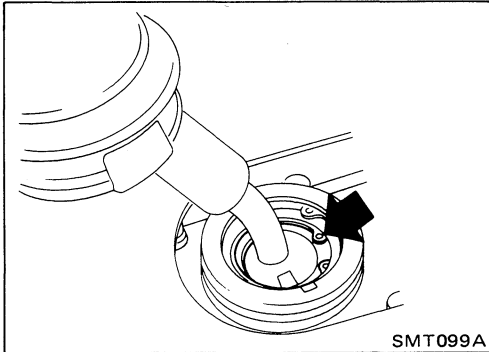

- Remove shift lever.
- Support engine by placing a jack under oil pan.

CAUTION:

Do not place jack under the oil pan drain plug.

- Remove transmission from engine.

WARNING:

Support Manual Transmission, while removing it.

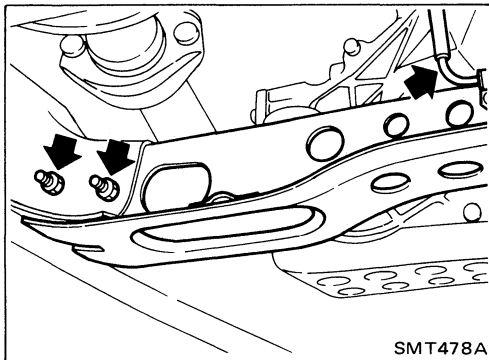

Removal — 4WD Model

- Remove front and rear propeller shafts. — Refer to section PD.
- Insert plug into rear oil seal of transfer after removing propeller shaft.

CAUTION:

Be careful not to damage spline, sleeve yoke and rear oil seal of transfer, when removing propeller shaft.

- Remove exhaust front tube A. (VG30i engine model) — Refer to section FE.

- Remove torsion bar springs. — Refer to REMOVAL of Torsion Bar Spring in section FA. Then remove second crossmember.

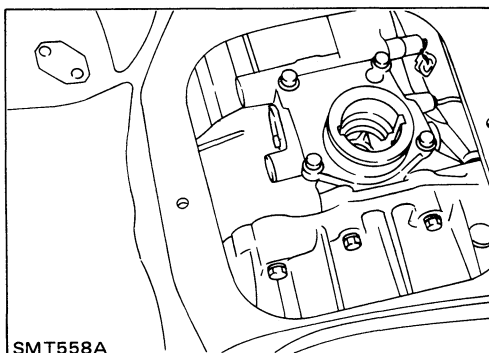

- Remove shift lever of transmission and transfer.
- Support engine by placing a jack under oil pan.

CAUTION:

Do not place jack under the oil pan drain plug.

- Remove transmission with transfer from engine.

WARNING:

Support Manual Transmission with transfer, while removing it.

Installation

- Apply sealant as below: – 4WD model

Z24i engine model

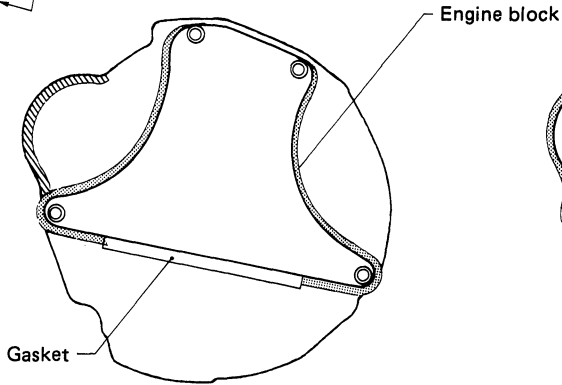
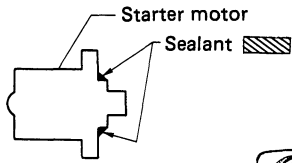

Mating surface of engine block and engine rear plate

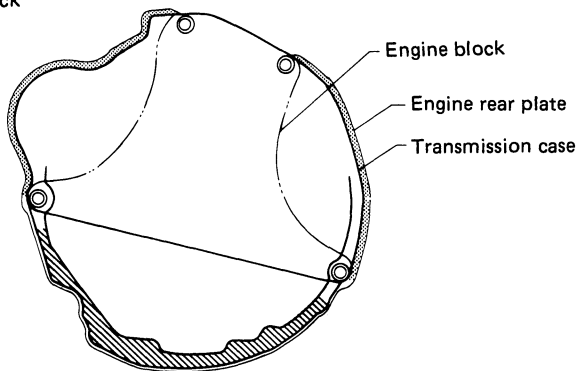

Mating surface of engine rear plate and transmission case

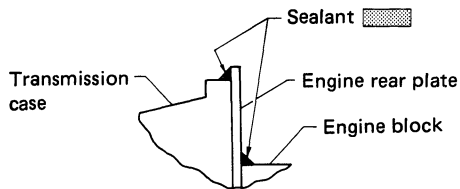

▨ : Apply recommended sealant (Nissan genuine part: KP510-00150) or equivalent.

▧ : Apply recommended sealant (Nissan genuine part: KP610-00250) or equivalent.

SMT481A

VG30i engine model

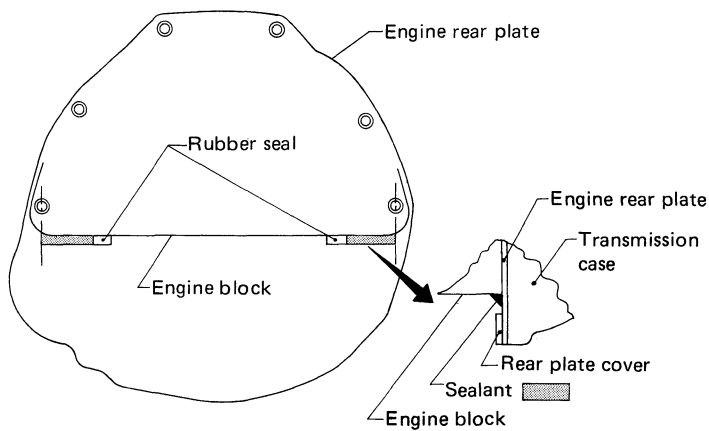

Mating surface of engine block and engine rear plate

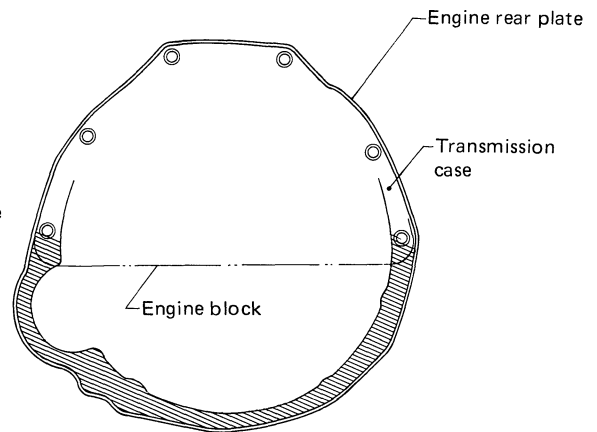

Mating surface of engine rear plate and transmission case

▨ : Apply recommended sealant (Nissan genuine part: KP510-00150) or equivalent.

▧ : Apply recommended sealant (Nissan genuine part: KP610-00250) or equivalent.

SMT572A

Installation (Cont'd)

- Tighten bolt securing transmission.
- **Z24i engine model**

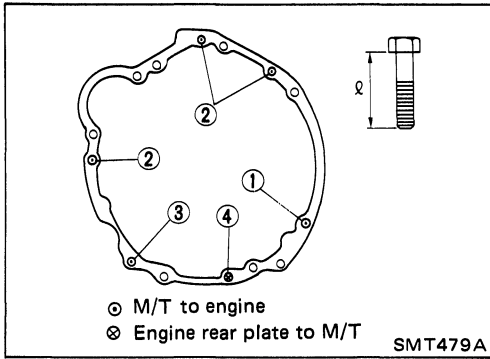

Bolt No.	Tightening torque N·m (kg·m, ft·lb)	ℓ mm (in)
1	39 - 49 (4.0 - 5.0, 29 - 36)	65 (2.56)
2	39 - 49 (4.0 - 5.0, 29 - 36)	60 (2.36)
3*	19 - 25 (1.9 - 2.5, 14 - 18)	25 (0.98)
4	19 - 25 (1.9 - 2.5, 14 - 18)	16 (0.63)

*: With nut

- **VG30i engine model**

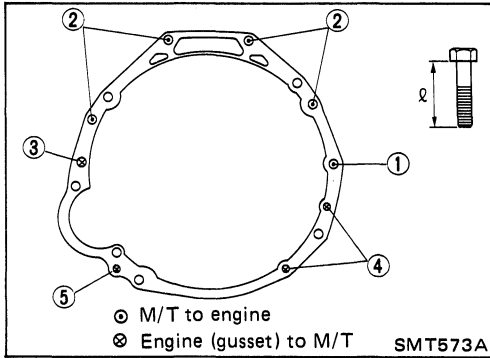

Bolt No.	Tightening torque N·m (kg·m, ft·lb)	ℓ mm (in)
1	39 - 49 (4.0 - 5.0, 29 - 36)	65 (2.56)
2	39 - 49 (4.0 - 5.0, 29 - 36)	60 (2.36)
3	29 - 39 (3.0 - 4.0, 22 - 29)	55 (2.17)
4	29 - 39 (3.0 - 4.0, 22 - 29)	30 (1.18)
5	29 - 39 (3.0 - 4.0, 22 - 29)	25 (0.98)

Case Components — FS5W71C and F4W71C
(2WD & 4WD)

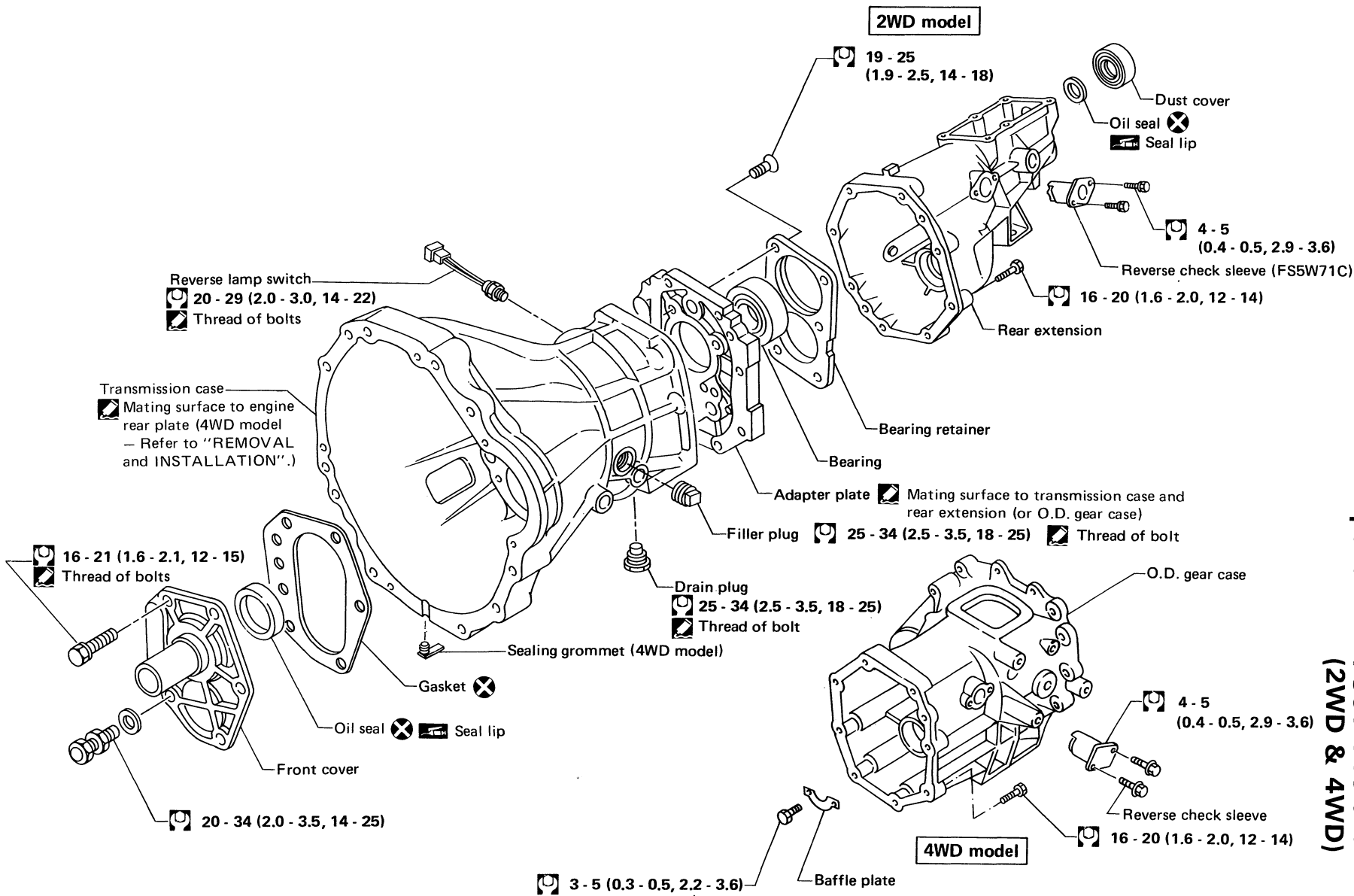

- : N-m (kg-m, ft-lb)
- : Apply recommended sealant (Nissan genuine part: KP610-00250) or equivalent.

Gear Components — FS5W71C

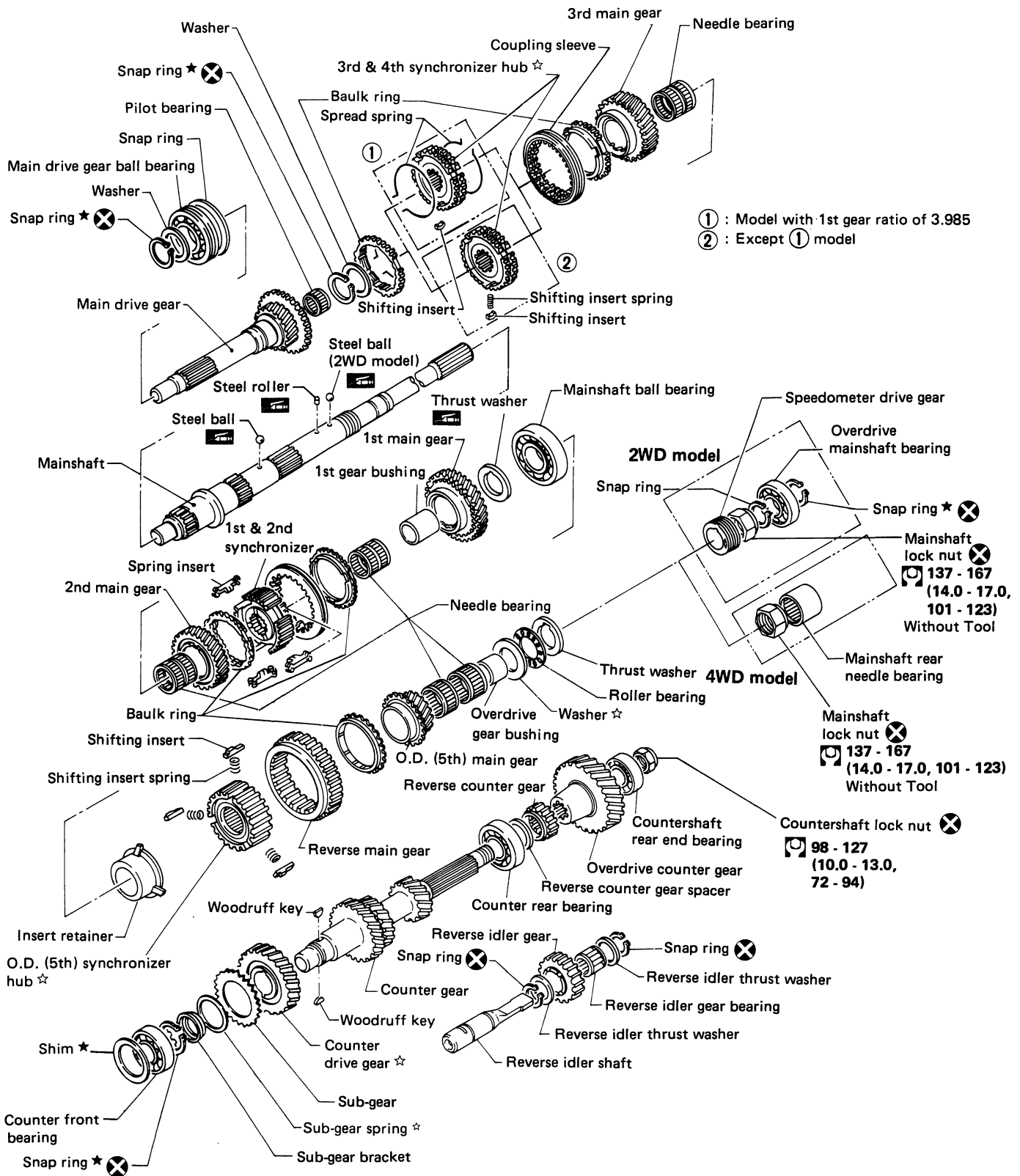

Apply gear oil to gears, shafts, synchronizers, and bearings when assembling.

- ★ Select with proper thickness.
- ☆ Pay attention to its direction.
- ☞ : N·m (kg·m, ft·lb)

Gear Components — F4W71C

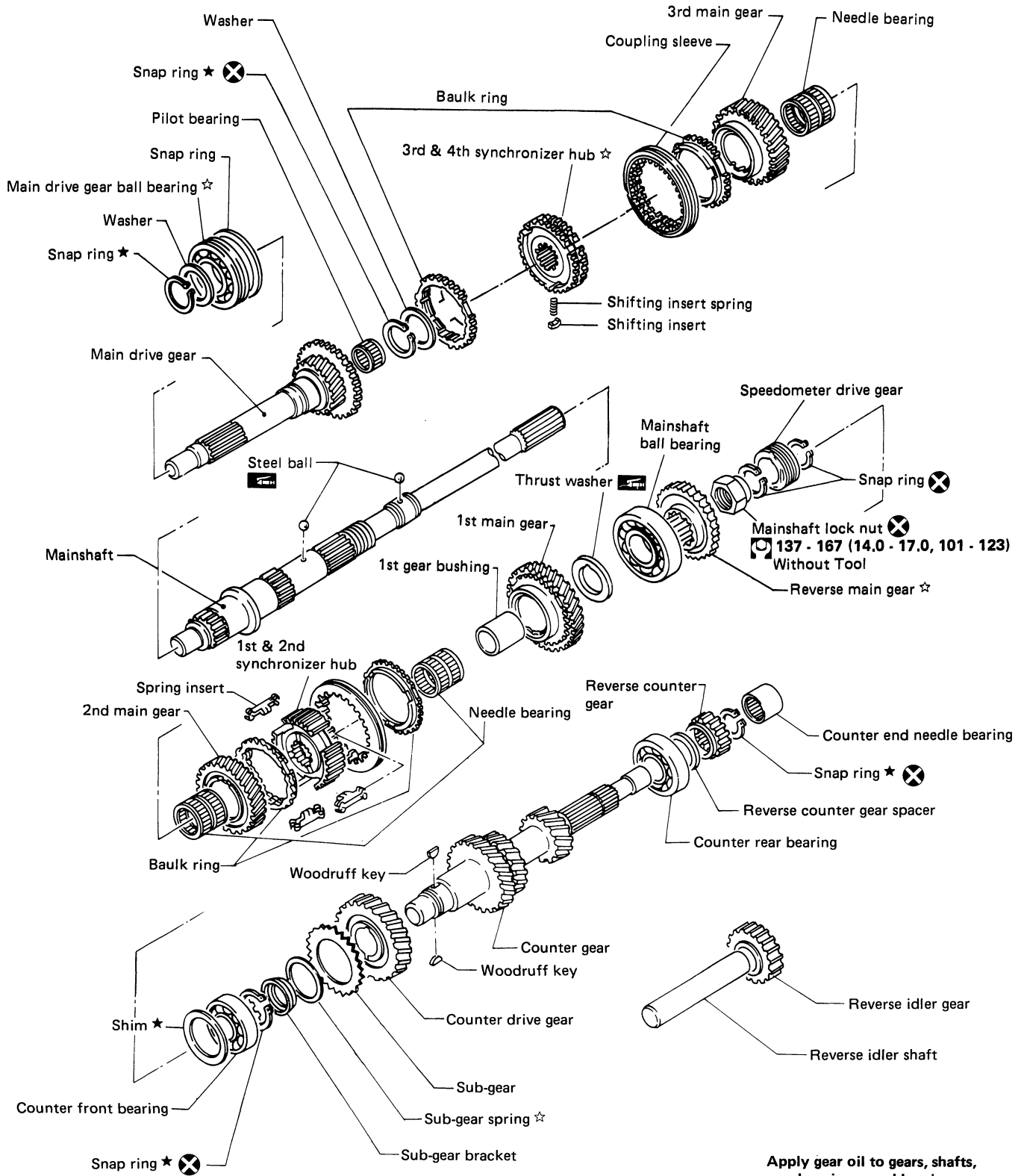

Apply gear oil to gears, shafts, synchronizers, and bearings when assembling.

- ★ Select with proper thickness.
- ☆ Pay attention to its direction.

◻ : N·m (kg·m, ft·lb) SMT058B

Shift Control Components —
FS5W71C (2WD model) and F4W71C

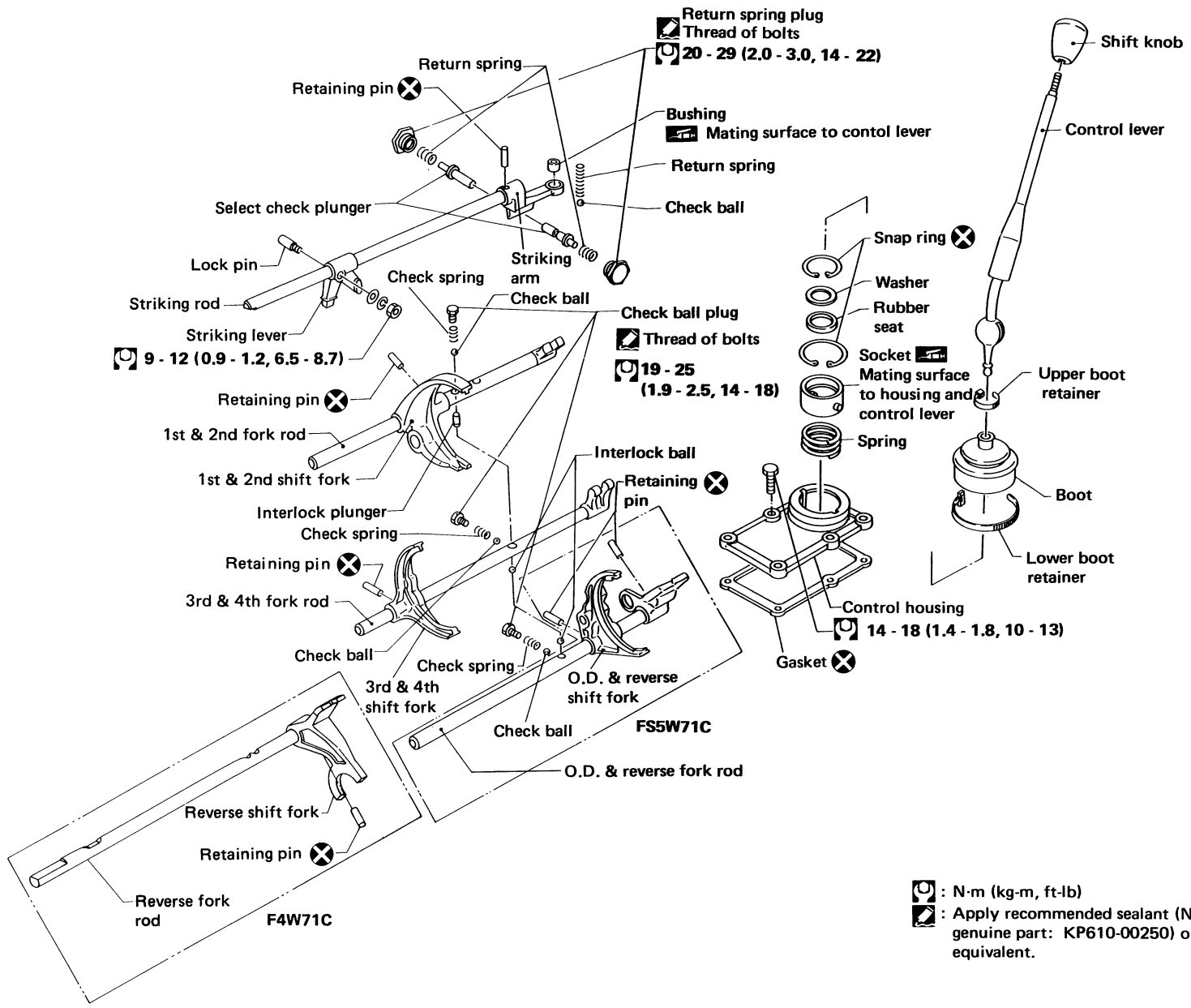

- : N·m (kg·m, ft·lb)
- : Apply recommended sealant (Nissan genuine part: KP610-00250) or equivalent.

MT-13

SMT543A

Shift Control Components — FS5W71C
(4WD model)

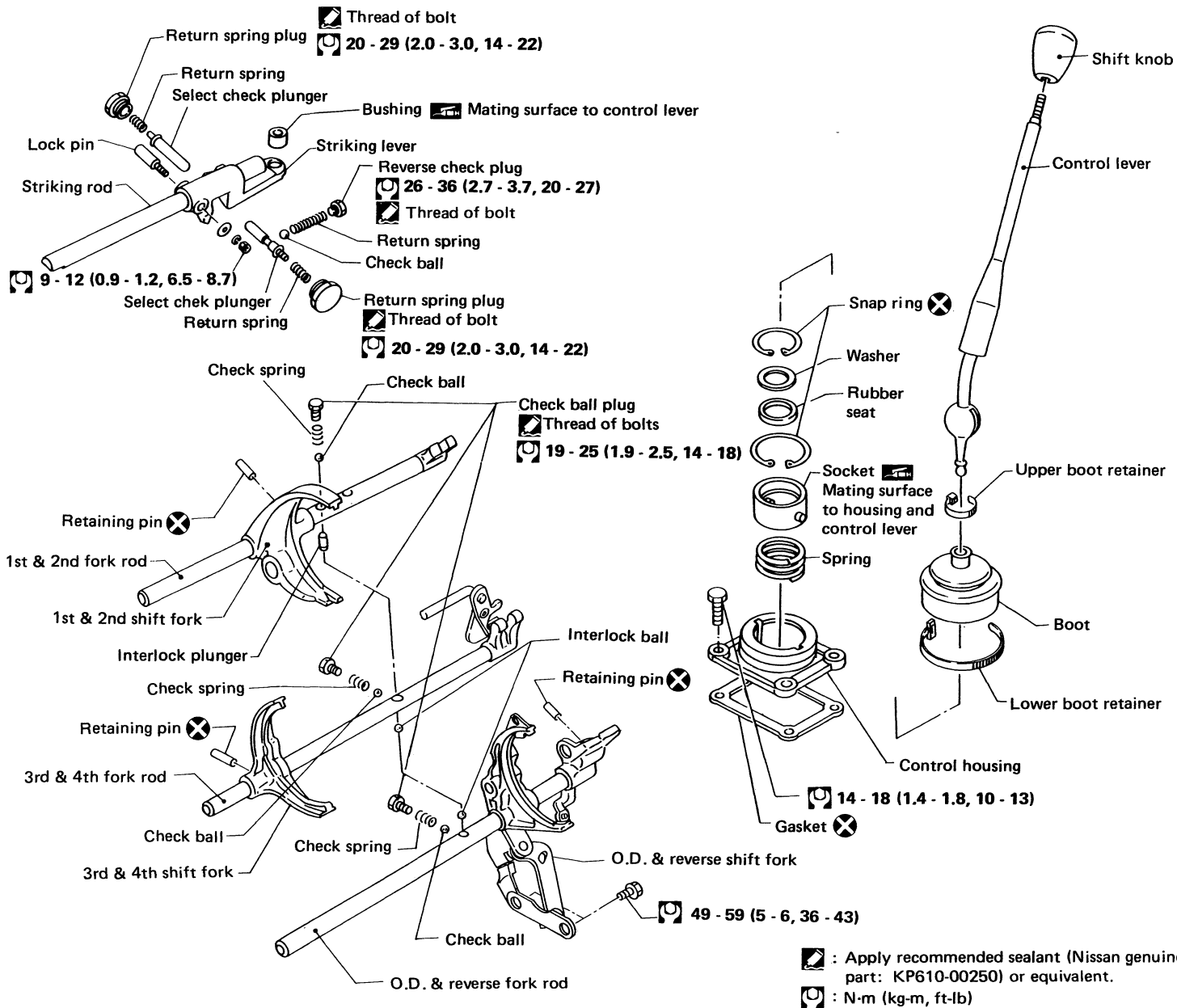

MT-14

SMT057B

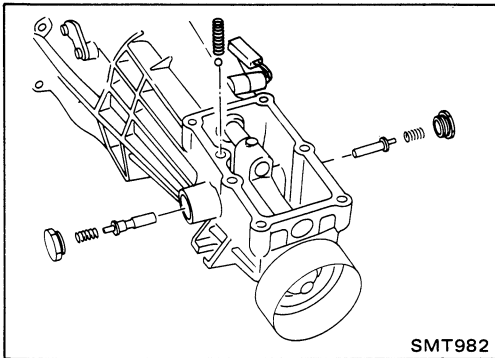

Case Components

1. Remove rear extension.
 - a. Remove control housing, check ball, return spring plug, select check plunger and return springs.

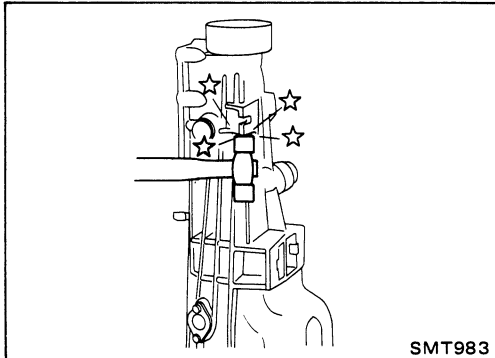

- b. Remove rear extension by lightly tapping it.

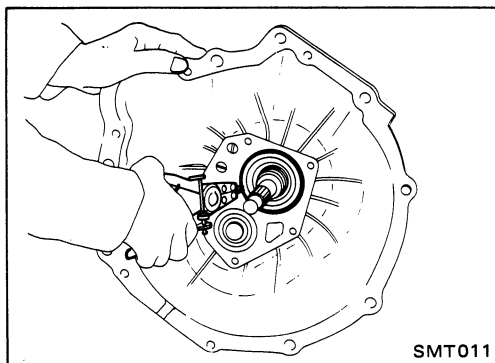

2. Remove front cover, gasket, shim of countershaft front bearing, and snap ring of main drive gear ball bearing.

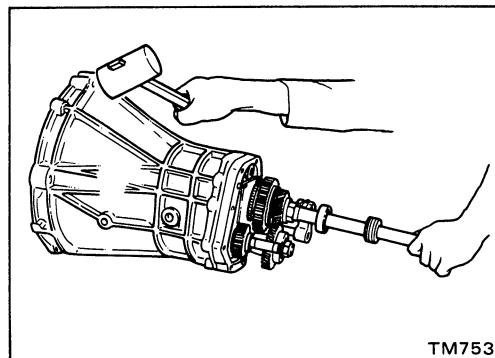

3. Separate transmission case from adapter plate.

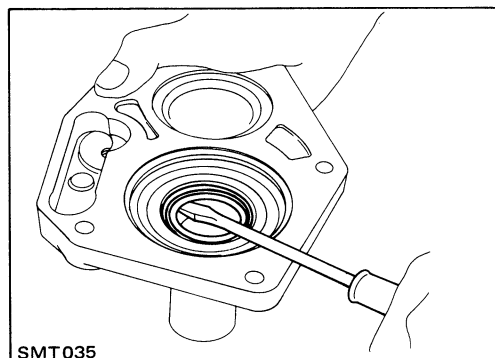

4. Remove oil seal of front cover.
Be careful not to damage mating surface of front cover.

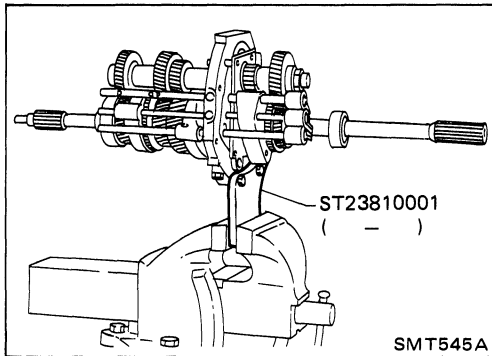

Shift Control Components

1. Set up Tool on adapter plate.
2. Remove check ball plugs, check springs, and check balls.

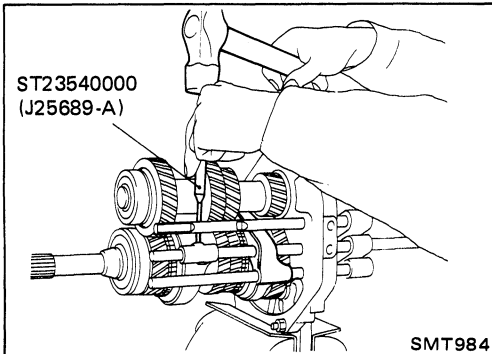

3. Drive out retaining pins. Then drive out fork rods and remove interlock balls.

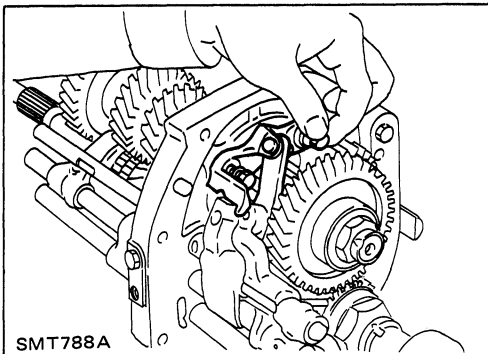

4. Remove lever bracket securing bolt (4WD model with main-shaft braking mechanism only).

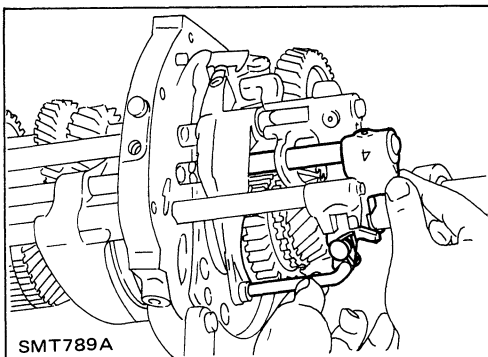

5. Draw out 3rd-4th fork rod (4WD model only).

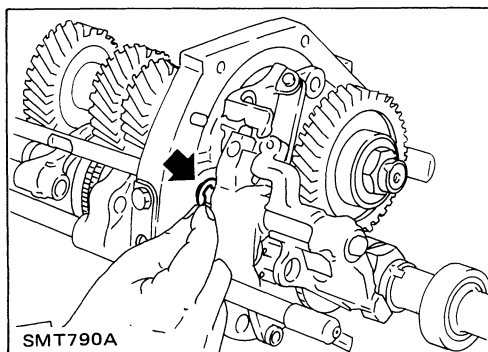

6. Remove E-ring from O.D.-rev. fork rod (4WD model only).

Shift Control Components (Cont'd)

7. Draw out O.D.-rev. fork shaft by rotating O.D.-rev. bracket counterclockwise (4WD model only).

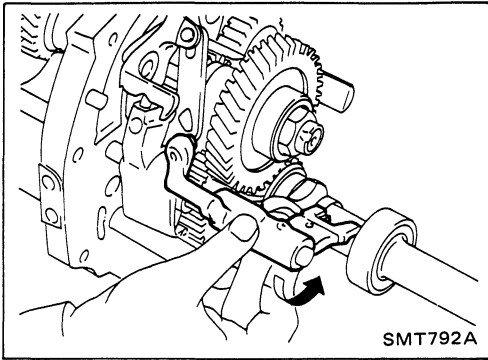

Gear Components

1. Before disassembly, measure each gear end play.
 - If end play is not within the specified limit, disassemble and check the parts.
 - Replace any part which is worn or damaged.

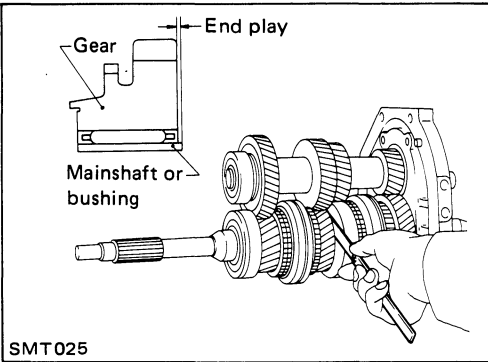

Gear	End play mm (in)
1st	0.31 - 0.41 (0.0122 - 0.0161)
2nd	0.11 - 0.21 (0.0043 - 0.0083)
3rd	0.11 - 0.21 (0.0043 - 0.0083)
O.D. (FS5W71C)	0.24 - 0.41 (0.0094 - 0.0161)

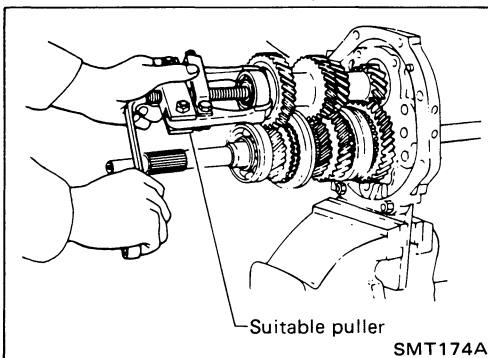

2. Mesh 2nd and reverse gear, then draw out counter front bearing with suitable puller.
3. Remove snap ring and then remove sub-gear bracket, sub-gear spring and sub-gear.

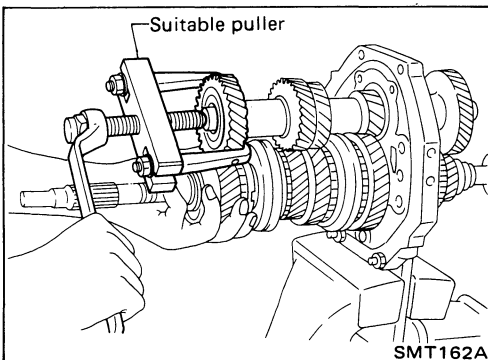

4. Draw out counter drive gear with main drive gear assembly with suitable puller.
 - When drawing out main drive gear assembly, be careful not to drop pilot bearing and baulk ring.
5. Remove snap ring and draw out 3rd & 4th synchronizer and 3rd gear.

Gear Components (Cont'd)

6. Disassemble parts at rear of adapter plate as follows:

– **FS5W71C** –

- a. Release staking on countershaft nut and mainshaft nut and loosen these nuts.

Mainshaft nut: Left-hand thread

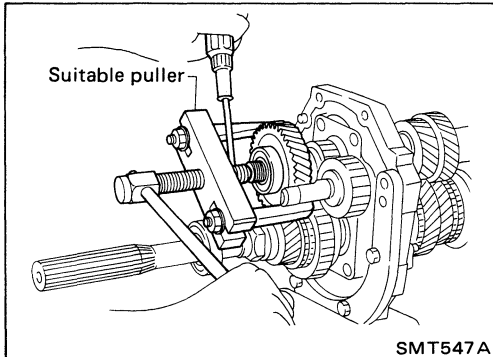
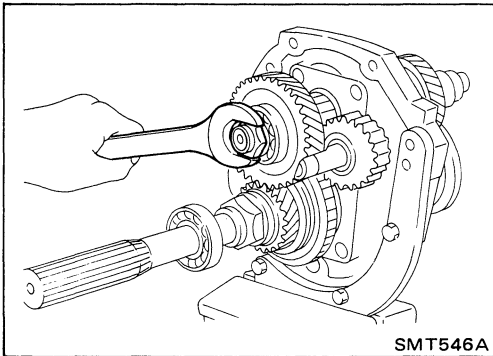

- b. Pull out O.D. counter gear with bearing with suitable puller.
c. Draw out reverse counter gear and spacer.
d. Remove snap rings from reverse idler shaft, and draw out reverse idler gear, thrust washers and reverse idler gear bearing.

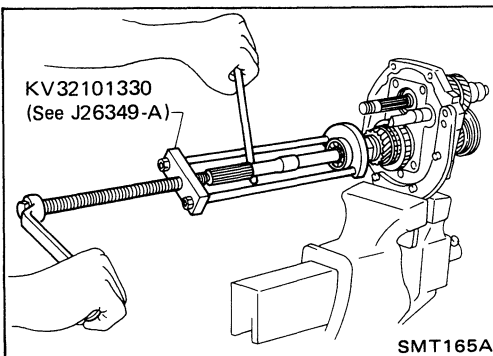

- e. Remove snap ring and pull out overdrive mainshaft bearing, then remove snap ring. (2WD model)

- f. Remove mainshaft nut.

- g. Remove speedometer drive gear and steel ball. (2WD model)

- h. Remove thrust washer, steel roller, roller bearing and washer.

- i. Remove O.D. main gear, needle bearing and baulk ring (O.D.).

- j. Remove O.D. coupling sleeve, shifting inserts and shifting insert springs.

- k. Remove counter gear by tapping rear end of counter gear.

- l. Press out O.D. gear bushing, insert retainer and O.D. synchronizer hub.

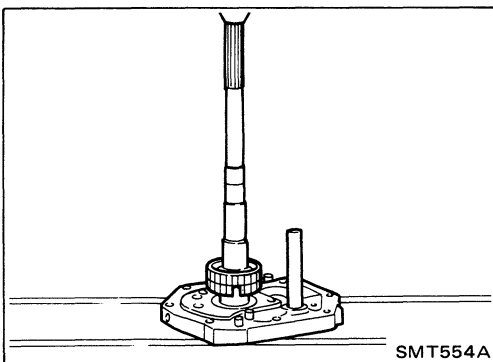

– **F4W71C** –

- a. Remove snap rings, speedometer drive gear and steel ball.

- b. Release staking on mainshaft nut and loosen it.

- c. Remove mainshaft nut and reverse main gear.

- d. Remove snap ring of countershaft rear end, and remove reverse counter gear.

- e. Remove reverse idler gear.

- f. Remove counter gear by tapping rear end of counter gear.

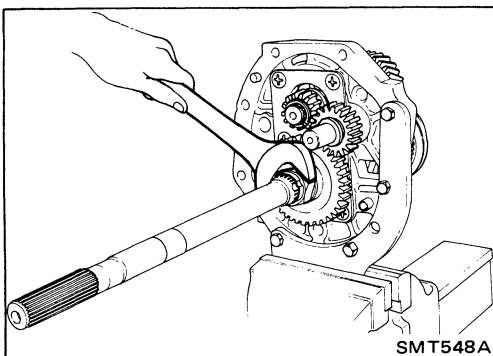

Gear Components (Cont'd)

- g. Draw out mainshaft assembly by tapping rear end of mainshaft.

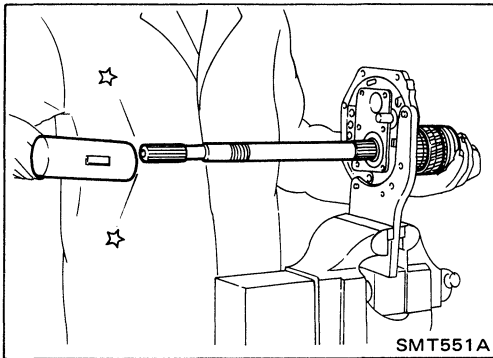

7. Remove thrust washer, steel ball, 1st main gear and needle bearing.

Be careful not to lose steel ball.

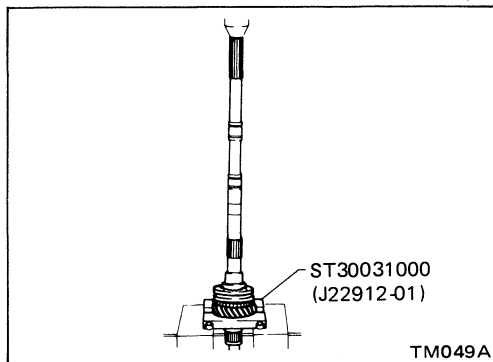

8. Press out 1st gear mainshaft bushing together with 2nd main gear with Tool.
Then remove 2nd gear needle bearing.

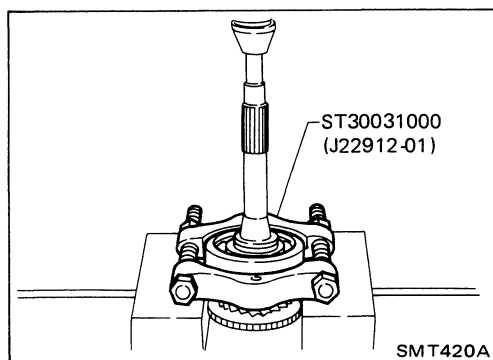

9. Remove main drive gear bearing.
a. Remove snap ring and washer.
b. Remove main drive gear bearing.

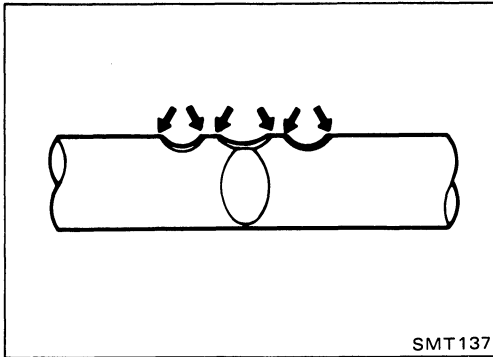

SMT137

Shift Control Components

- Check contact surface and sliding surface of fork rods for wear, scratches, projections or other damage.

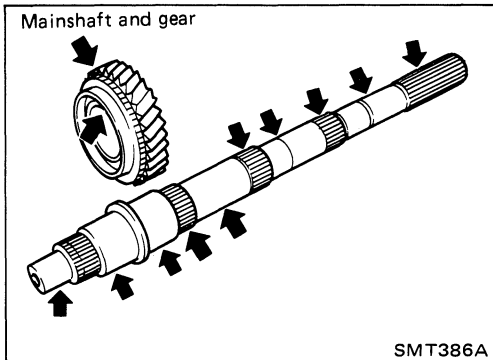

SMT386A

Gear Components

GEARS AND SHAFTS

- Check shafts for cracks, wear or bending.
- Check gears for excessive wear, chips or cracks.

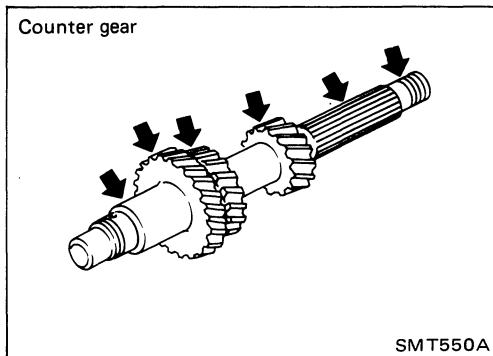

SMT550A

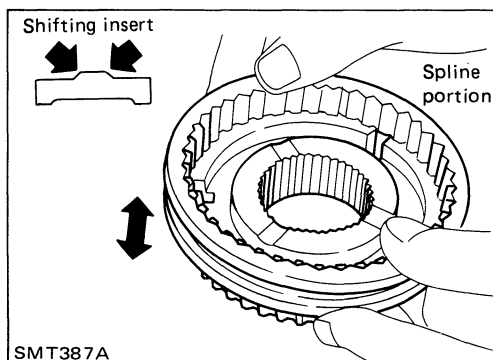

SMT387A

SYNCHRONIZERS

- Check spline portion of coupling sleeves, hubs and gears for wear or cracks.
- Check baulk rings for cracks or deformation.
- Check shifting inserts for wear or deformation.
- Check insert springs for deformation.

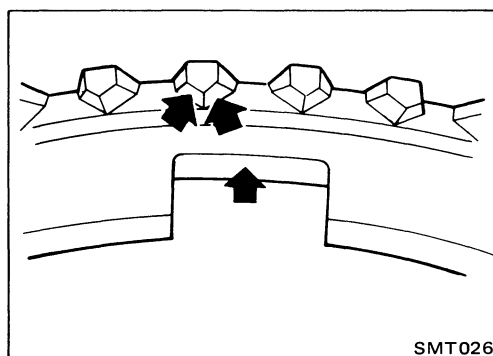

SMT026

Gear Components (Cont'd)

- Measure clearance between baulk ring and gear.

Clearance between baulk ring and gear

Unit: mm (in)

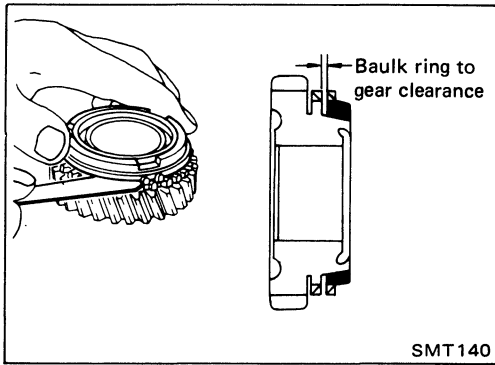

	Standard	Wear limit
1st & 2nd	1.20 - 1.60 (0.0472 - 0.0630)	0.80 (0.0315)
3rd & main drive	1.20 - 1.60 (0.0472 - 0.0630)	0.80 (0.0315)
O.D. (FS5W71C)	1.20 - 1.60 (0.0472 - 0.0630)	0.80 (0.0315)

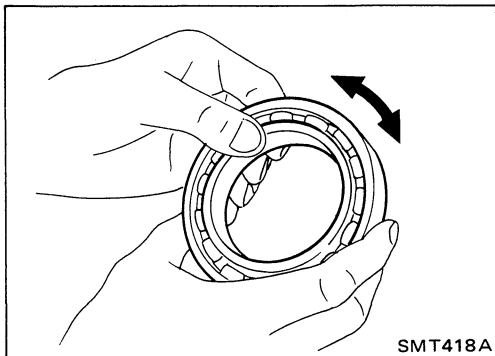

BEARINGS

- Make sure bearings roll freely and are free from noise, crack, pitting or wear.

Gear Components

1. Install bearings into case components.

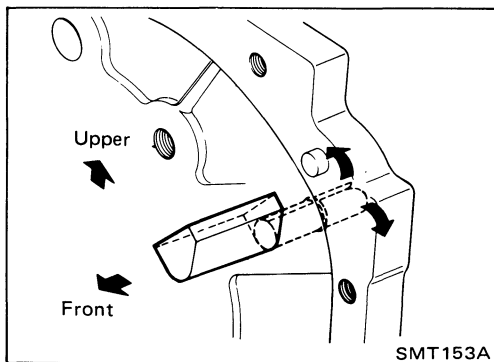
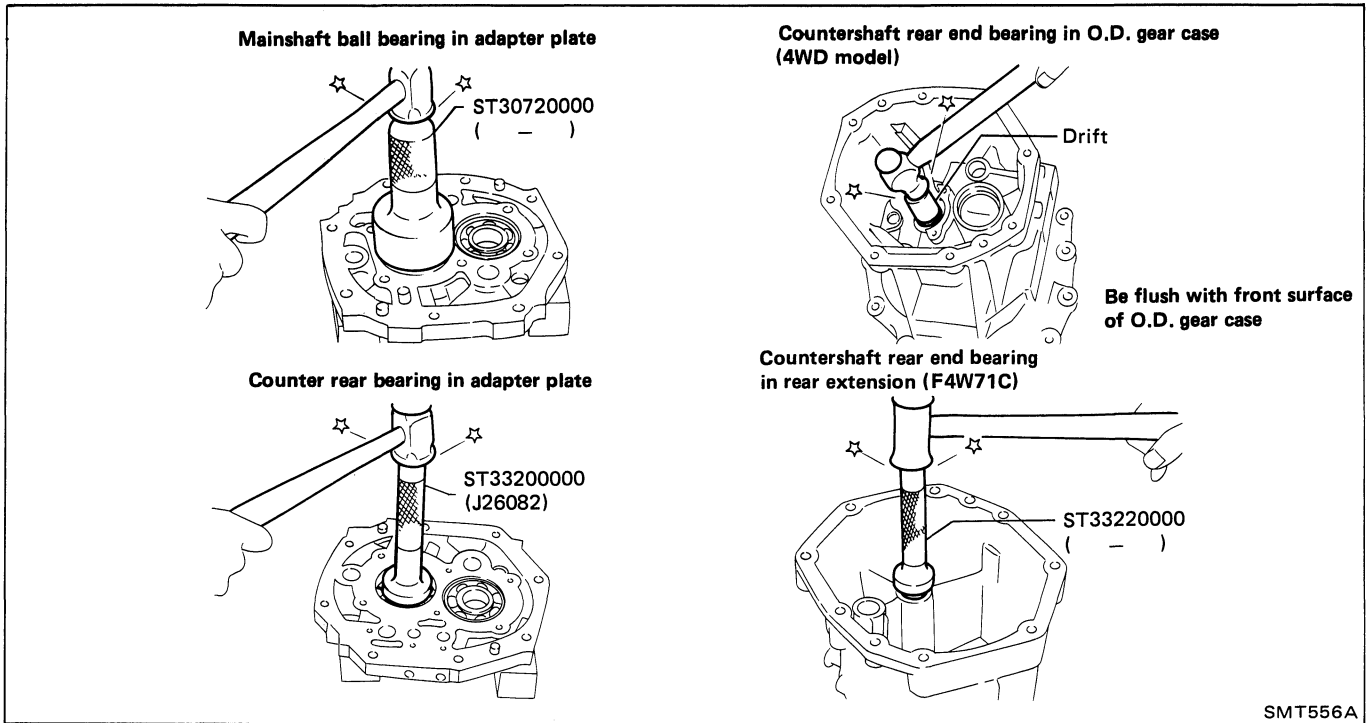

2. Assemble adapter plate parts.

- Install oil gutter on adapter plate and expand on rear side.

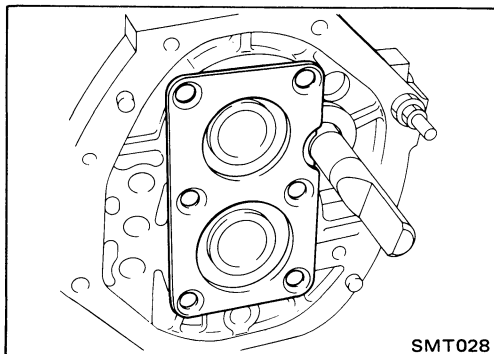

- Install bearing retainer.
- a. Insert reverse shaft, then install bearing retainer.

Gear Components (Cont'd)

- b. Tighten each screw, then stake it at two points.

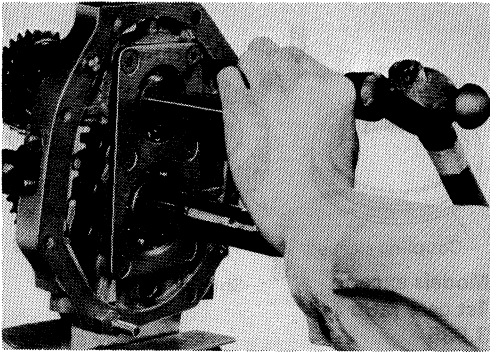

- 3. Install main drive gear bearing.
 - a. Press in main drive gear bearing.
 - b. Install main drive gear spacer.

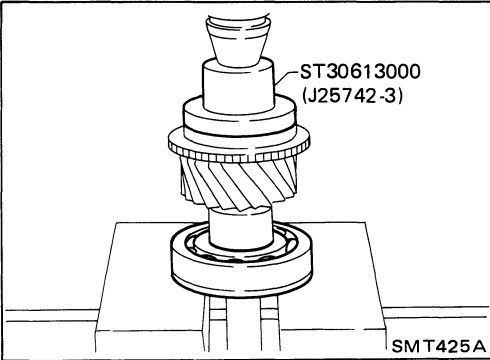

- c. Select proper main drive gear snap ring to minimize clearance of groove.

Allowable clearance of groove:

0 - 0.13 mm (0 - 0.0051 in)

Main drive gear snap ring

Thickness mm (in)	Part number
1.73 (0.0681)	32204-78005
1.80 (0.0709)	32204-78000
1.87 (0.0736)	32204-78001
1.94 (0.0764)	32204-78002
2.01 (0.0791)	32204-78003
2.08 (0.0819)	32204-78004

- d. Install selected snap ring on main drive gear.

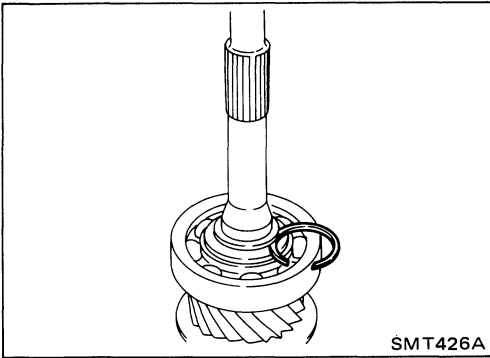

- 4. Assemble synchronizers.

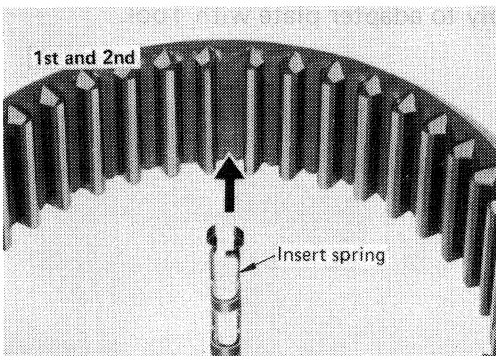

Gear Components (Cont'd)

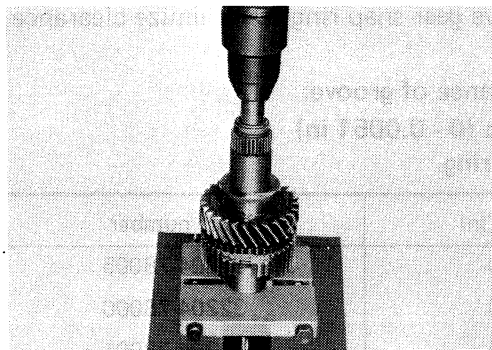
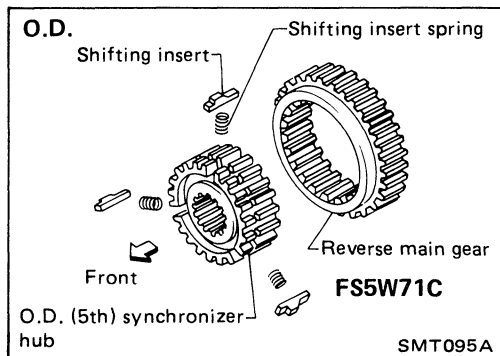
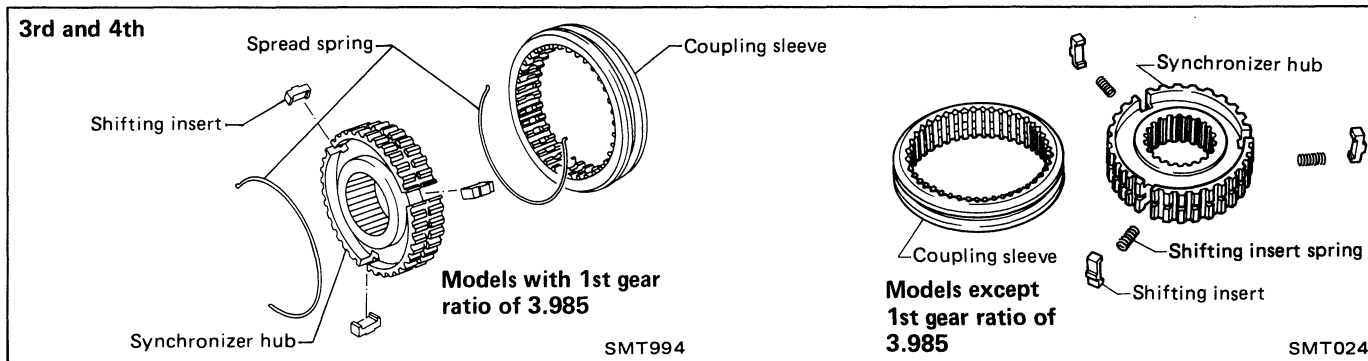

5. Assemble 2nd main gear, needle bearing and 1st & 2nd synchronizer assembly, then press 1st gear bushing on mainshaft.

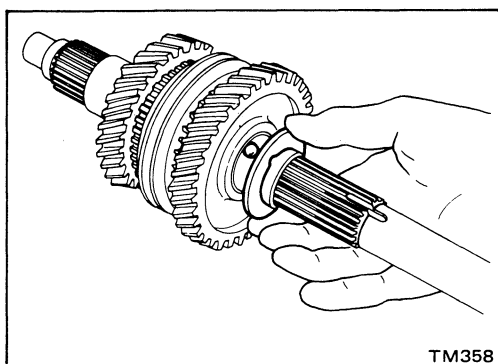

6. Assemble 1st main gear, steel ball, and thrust washer on mainshaft.
Before installing steel ball and thrust washer, apply grease to them.
7. Install counter rear bearing to adapter plate.

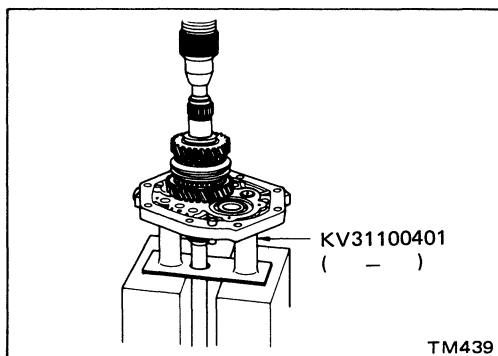

8. Press mainshaft assembly to adapter plate with Tool.

Gear Components (Cont'd)

9. Press counter gear into adapter plate with Tool.

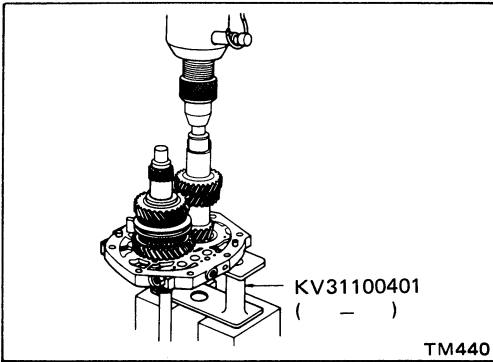

10. Install 3rd main gear and 3rd & 4th synchronizer assembly. Pay attention to direction of synchronizer.

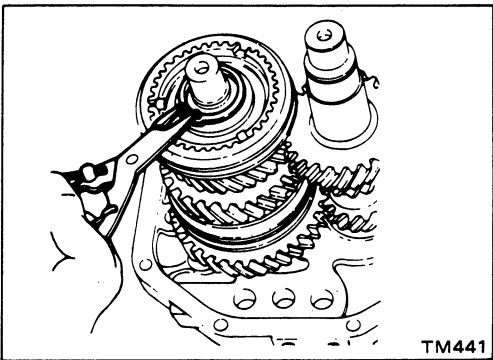
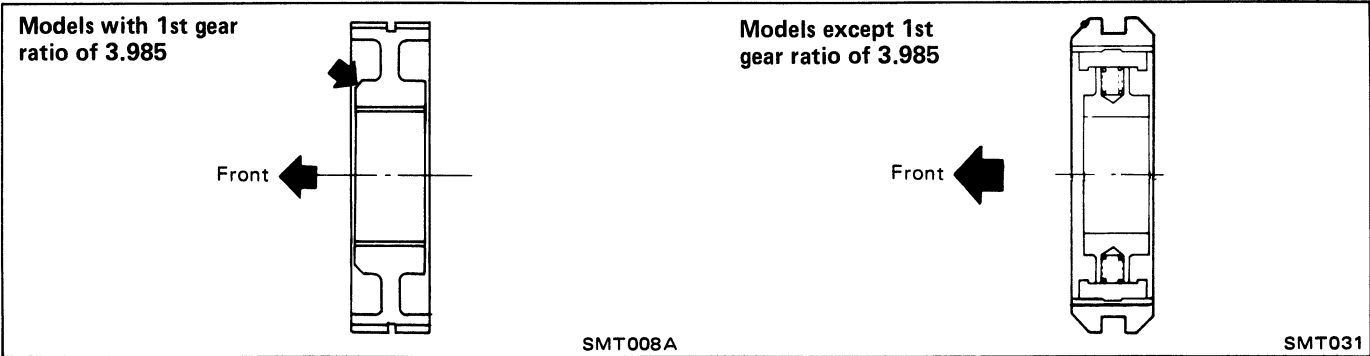

11. Install thrust washer on mainshaft and secure it with mainshaft front snap ring.

Select proper snap ring that will minimize clearance of groove in mainshaft.

Mainshaft front snap ring:

Refer to S.D.S.

12. Apply gear oil to mainshaft pilot bearing and install it on mainshaft.

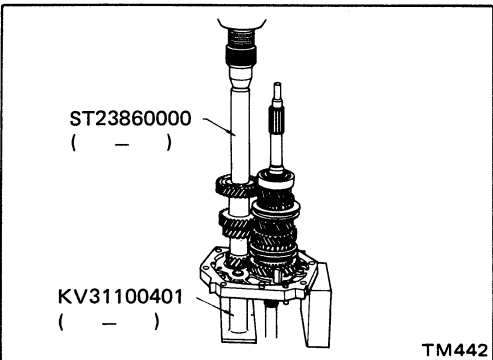

13. Press counter drive gear with main drive gear with Tool.

Pay attention to direction of counter drive gear.

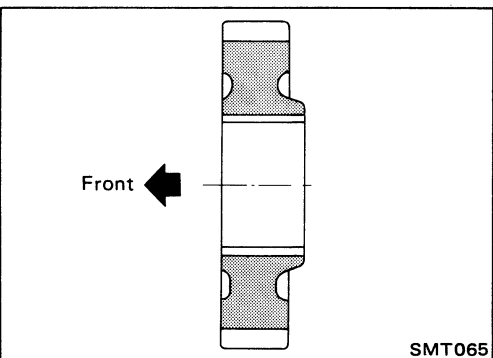

Gear Components (Cont'd)

14. Install sub-gear components.

- a. Install sub-gear and sub-gear bracket on counter drive gear and then select proper snap ring that will minimize clearance of groove in counter gear.

Allowable clearance of groove:

0 - 0.18 mm (0 - 0.0071 in)

Counter drive gear snap ring:

Parts number	Thickness mm (in)
32215-E9000	1.4 (0.055)
32215-E9001	1.5 (0.059)
32215-E9002	1.6 (0.063)

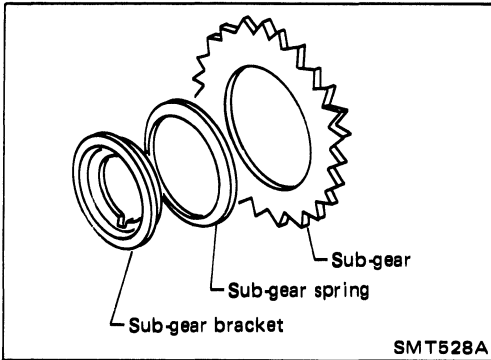

- b. Remove snap ring, sub-gear bracket and sub-gear from counter gear.
- c. Reinstall sub-gear and sub-gear bracket with sub-gear spring between them.

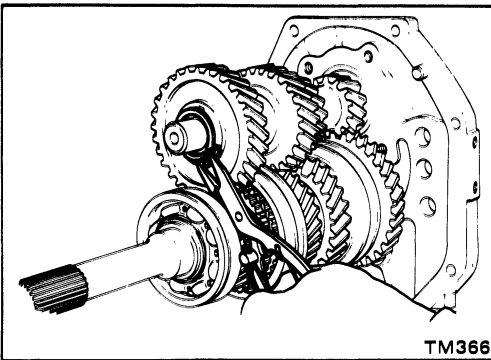

15. Install selected counter drive gear snap ring.

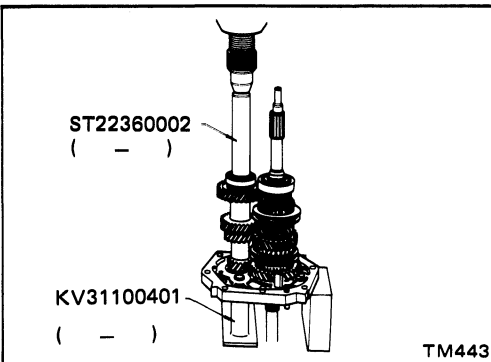

16. Press counter gear front bearing onto counter gear.

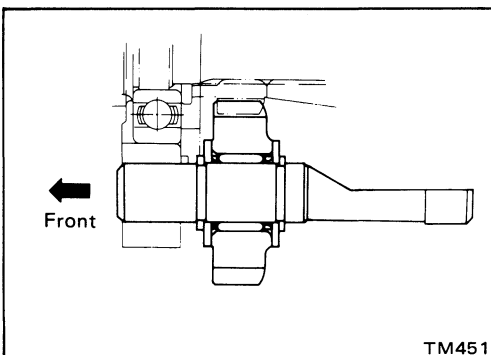

17. Assemble parts at rear of adapter plate as follows:

— FS5W71C —

- a. Install reverse idler gear to reverse idler shaft with spacers, snap rings and needle bearing.

Gear Components (Cont'd)

b. Install insert retainer and O.D. synchronizer to mainshaft.
Pay attention to direction of hub.

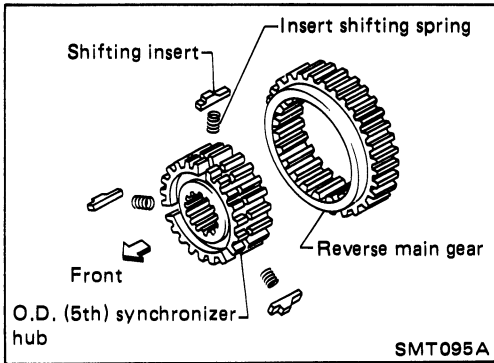

- c. Install O.D. gear bushing with Tool.
- d. Install O.D. main gear and needle bearing.
- e. Install spacer, reverse counter gear and O.D. counter gear.
O.D. main gear and O.D. counter gear should be handled as a matched set.
- f. Install washer, roller bearing, steel roller, thrust washer, steel ball and speedometer drive gear.
- g. Tighten mainshaft rock nut temporarily.
Always use new lock nut.

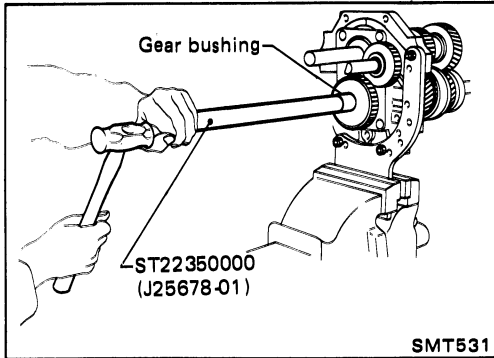

h. Install countershaft rear end bearing with Tool.

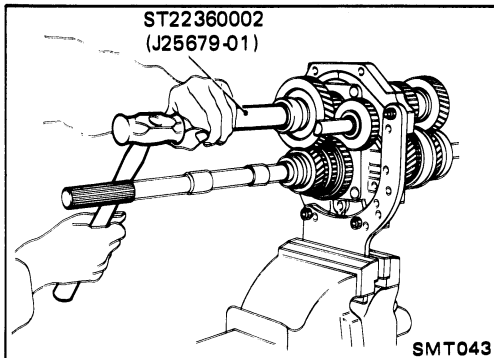

– F4W71C –

- a. Install reverse main gear, plain washer and mainshaft nut.
 Then tighten mainshaft nut temporarily.
Always use new lock nut.

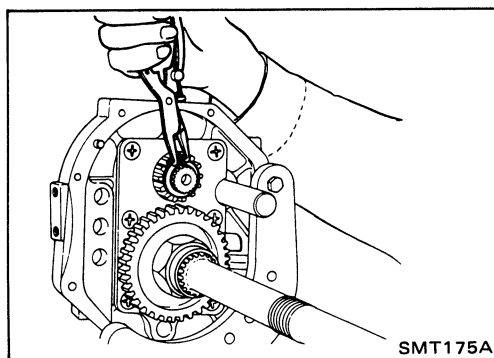

- b. Install counter reverse gear and secure with snap ring that will minimize clearance of groove in countershaft.

Counter reverse gear snap ring:

Part number	Thickness mm (in)
32228-E9200	1.4 (0.055)
32228-E9201	1.5 (0.059)
32228-E9202	1.6 (0.063)

- c. Install reverse idler gear.

Gear Components (Cont'd)

18. Mesh 2nd and reverse gears and tighten mainshaft lock nut with Tool.

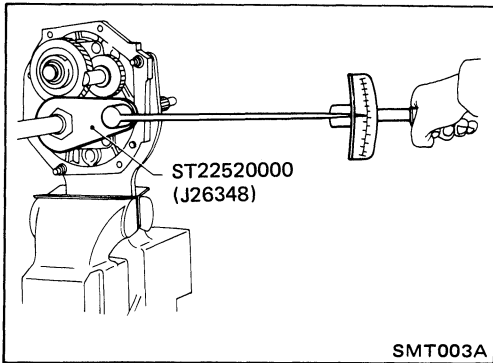

Use the left chart when deciding the reading torque (Length of torque wrench vs. setting or reading torque)

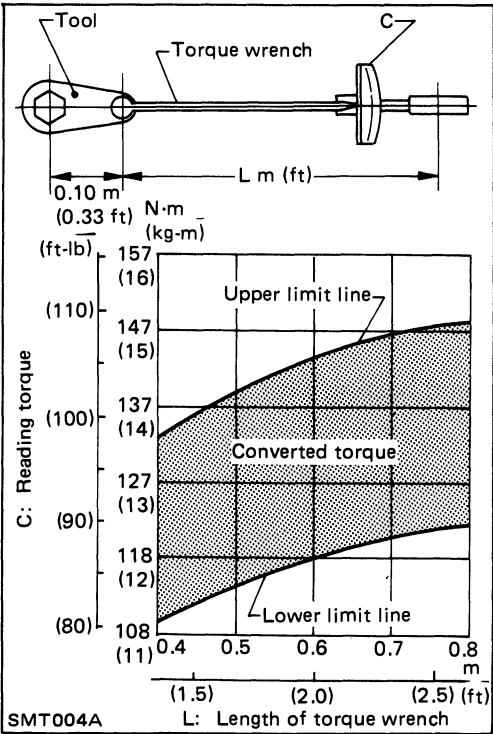

19. Tighten countershaft lock nut. (FS5W71C)

Always use new lock nut.

20. Stake mainshaft lock nut and countershaft lock nut with a punch.

21. Measure gear end play. For the description, refer to "DIS-ASSEMBLY".

Mainshaft

Countershaft

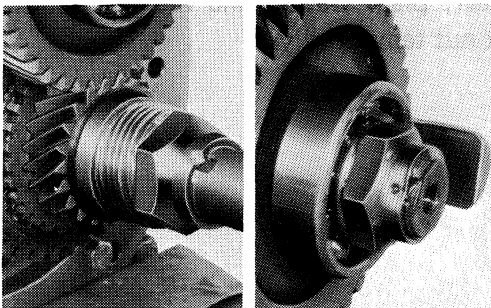

Shift Control Components

1. Install shift rods, interlock plunger, interlock balls and check balls.

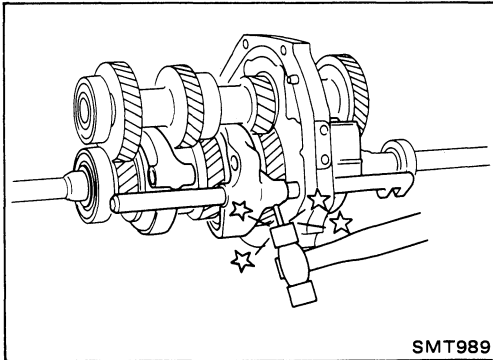
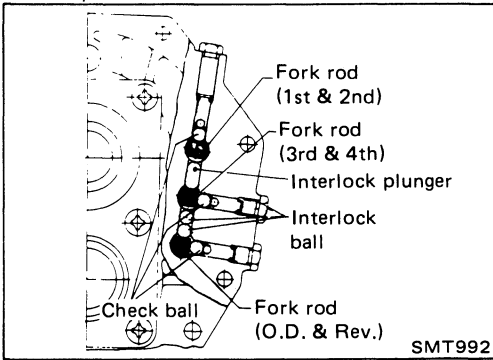

a. 1st-2nd shift fork

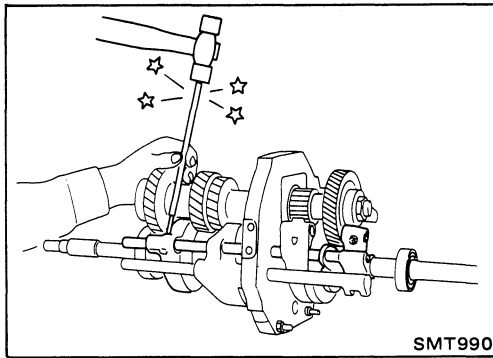

b. 3rd-4th shift fork

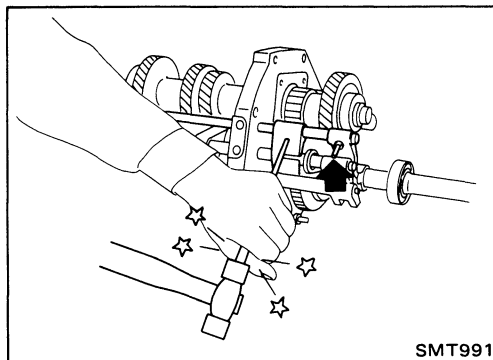

c. O.D.-reverse shift fork or reverse shift fork
– FS5W71C –

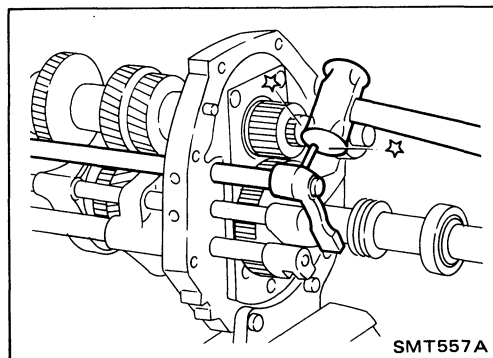

– F4W71C –

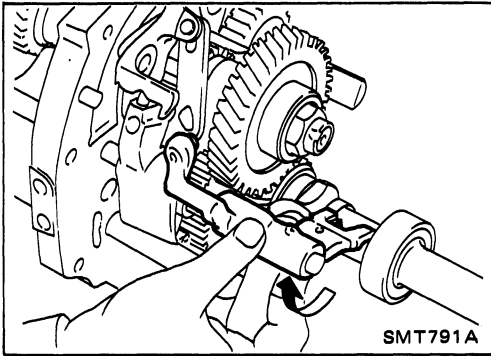
Shift Control Components (Cont'd)

2. Install O.D.-rev. fork shaft by rotating O.D.-rev. bracket clockwise (4WD model with mainshaft braking mechanism only).

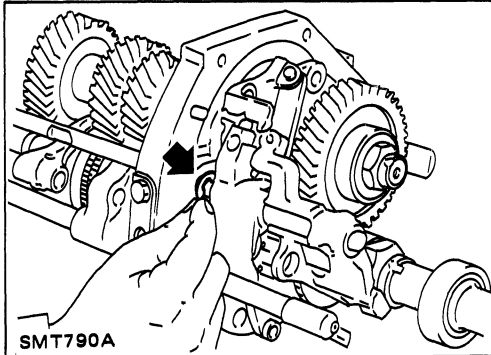

3. Install E-ring on O.D.-rev. fork rod (4WD model only).

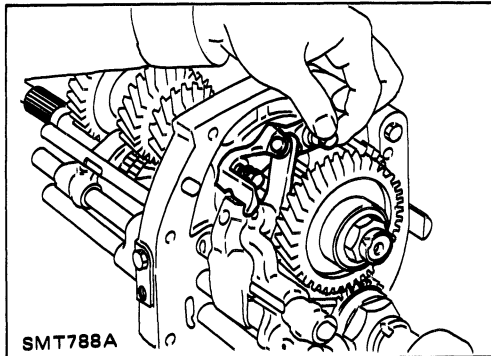

4. Install lever bracket securing bolt (4WD model only).

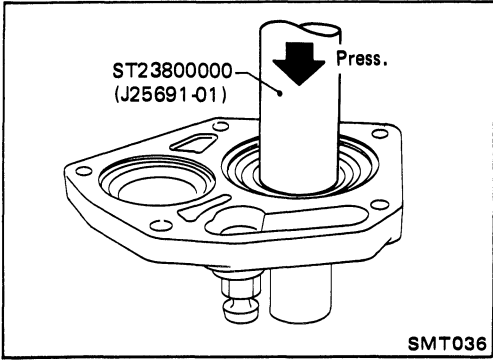

Case Components

1. Install front cover oil seal.
Apply multi-purpose grease to seal lip.

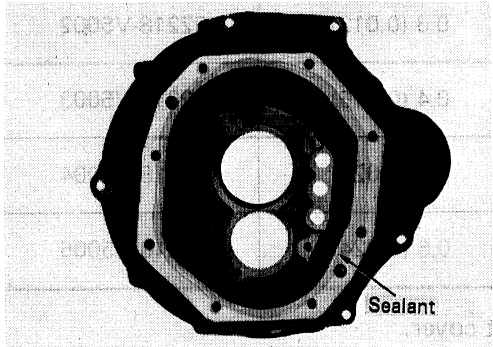

2. Apply sealant to mating surface of transmission case.

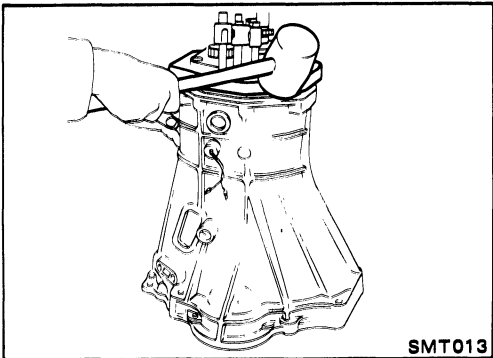

3. Slide gear assembly onto adapter plate by lightly tapping with a soft hammer.

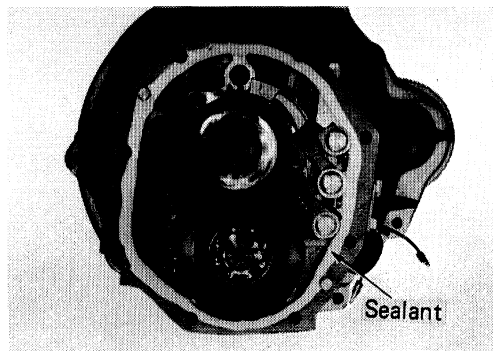

4. Apply sealant to mating surface of adapter plate.

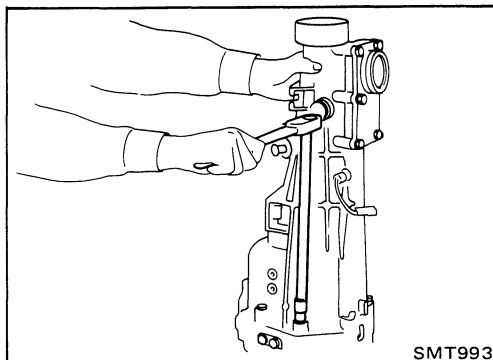

5. Install rear extension.
6. Fit main drive bearing snap ring.

Case Components (Cont'd)

7. Select counter front bearing shim.

Unit: mm (in)

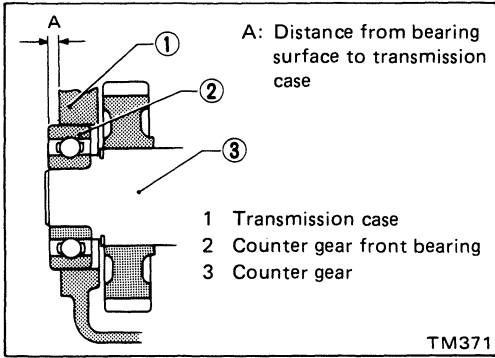

"A"	Thickness of shim	Part number
4.52 - 4.71 (0.1780 - 0.1854)	Not necessary	
4.42 - 4.51 (0.1740 - 0.1776)	0.1 (0.004)	32218-V5000
4.32 - 4.41 (0.1701 - 0.1736)	0.2 (0.008)	32218-V5001
4.22 - 4.31 (0.1661 - 0.1697)	0.3 (0.012)	32218-V5002
4.12 - 4.21 (0.1622 - 0.1657)	0.4 (0.016)	32218-V5003
4.02 - 4.11 (0.1583 - 0.1618)	0.5 (0.020)	32218-V5004
3.92 - 4.01 (0.1543 - 0.1579)	0.6 (0.024)	32218-V5005

8. Install gasket and front cover.

9. Install return spring plugs, check ball, return springs and select check plunger.

10. Install control housing and gasket.

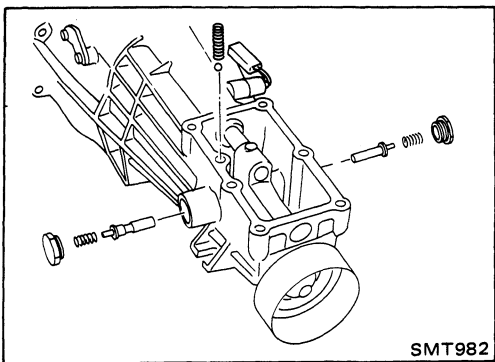

Case Components — FS5R30A

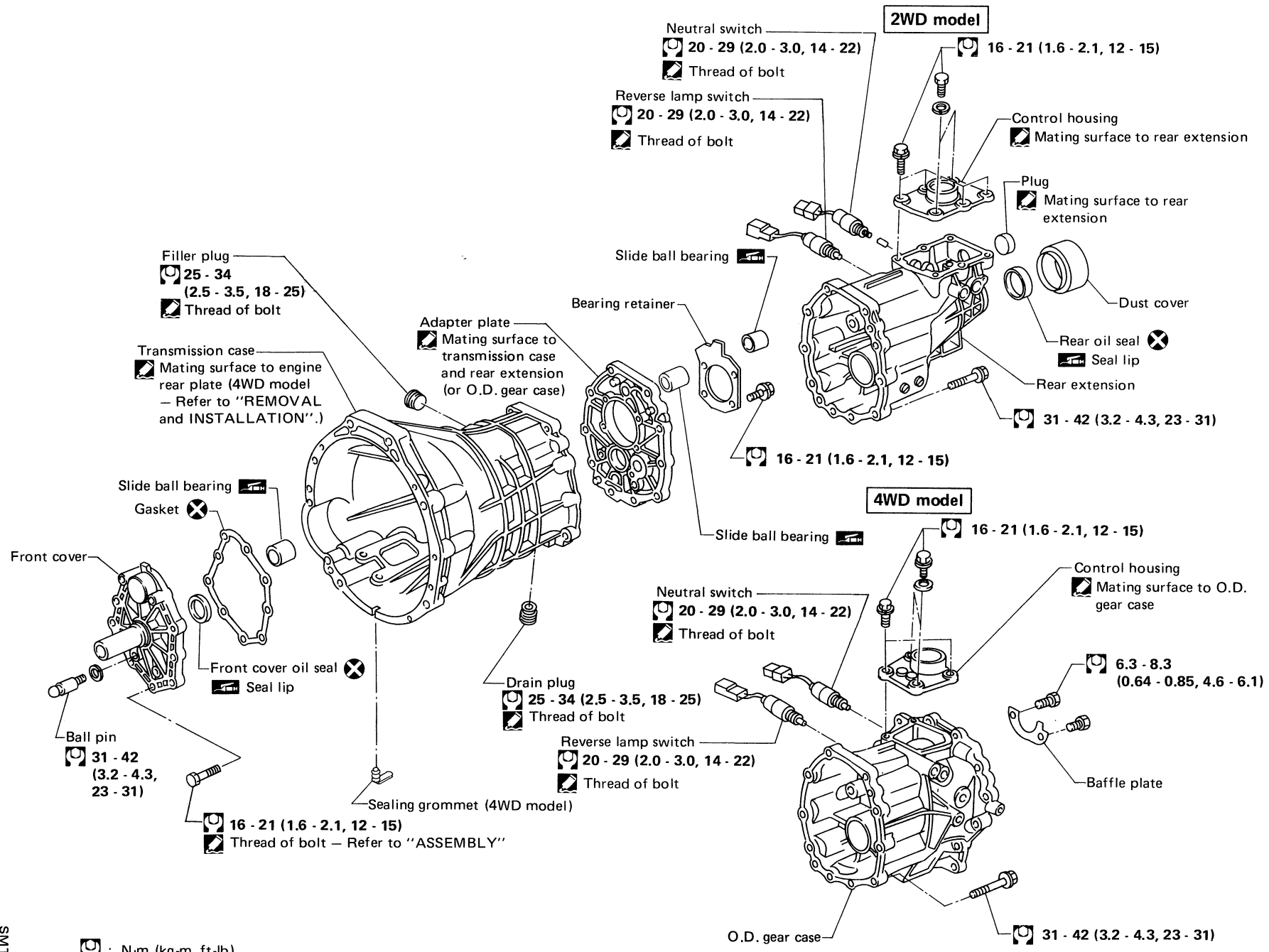

[Torque icon] : N-m (kg-m, ft-lb)
 [Sealant icon] : Apply recommended sealant (Nissan genuine part: KP610-00250) or equivalent.

MT-33

SMT434A

Gear Components — FS5R30A

MT-34

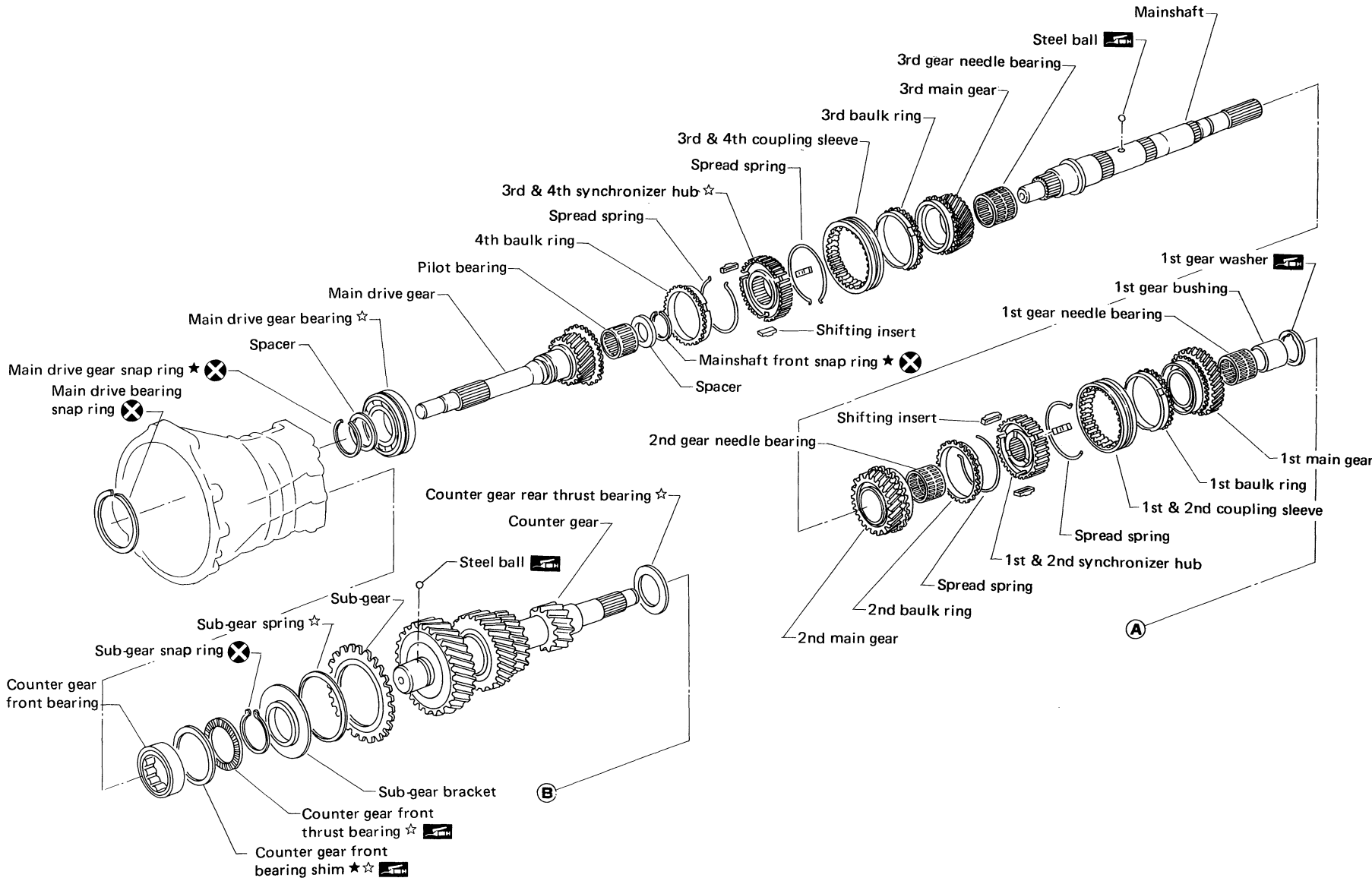

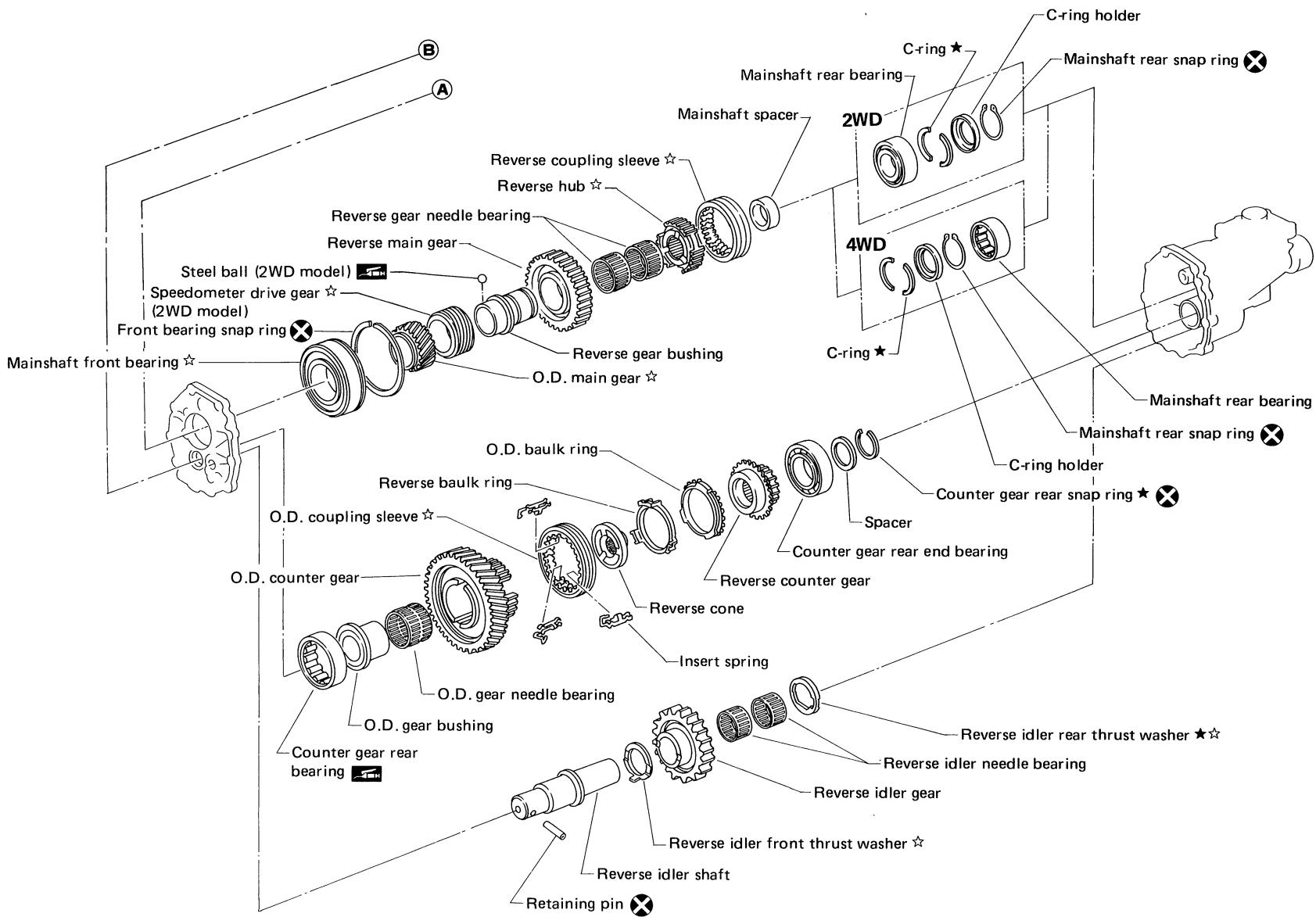

Apply gear oil to gears, shafts, synchronizers and bearings when assembling.

★ : Select with proper thickness

☆ : Pay attention to its direction

Shift Control Components — FS5R30A

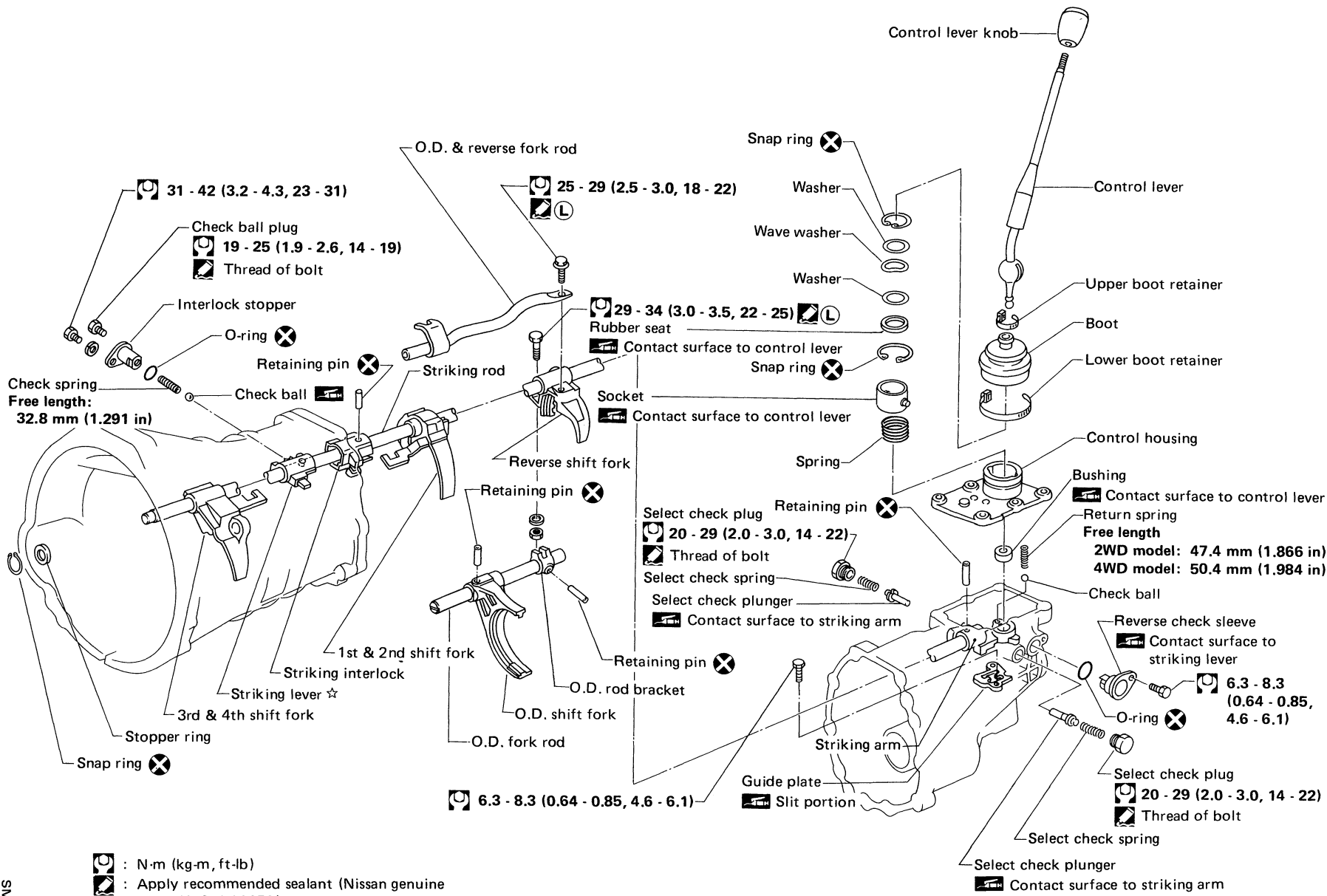

MT-36

SMT436A

- : N-m (kg-m, ft-lb)
- : Apply recommended sealant (Nissan genuine part: KP610-00250) or equivalent.
- : Apply locking sealant.
- ☆ : Pay attention to its direction.

Case Components

1. Remove check ball plug, check spring and check ball. Then remove interlock stopper.
If interlock assembly is removed as a unit, the check ball can fall into transmission case.

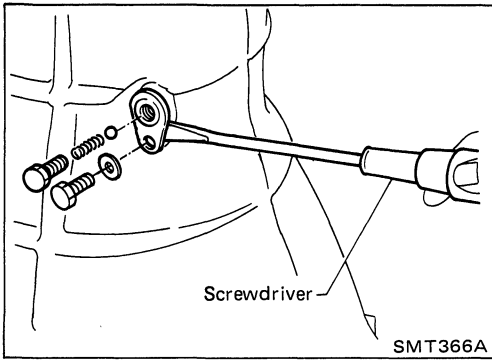

2. Remove control housing, return spring and check ball.

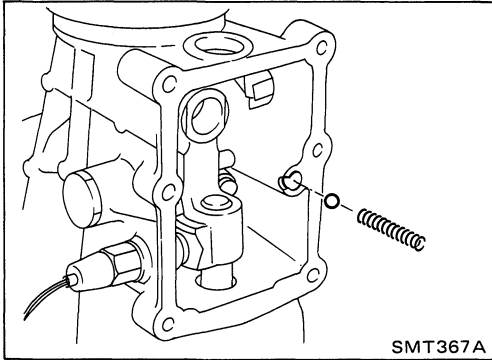

3. Drive out retaining pin from striking arm.

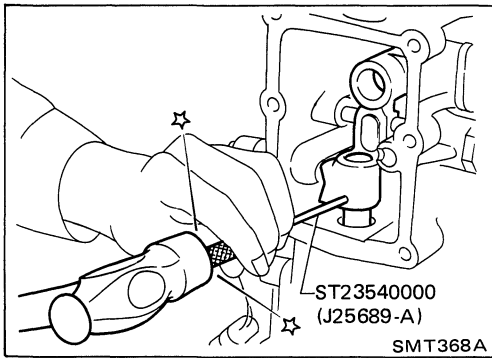

4. Remove rear extension (or O.D. gear case) together with striking arm by tapping lightly.

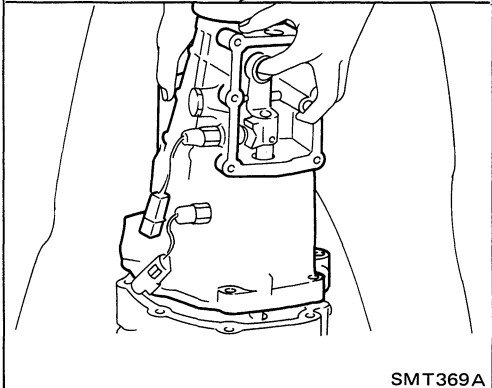
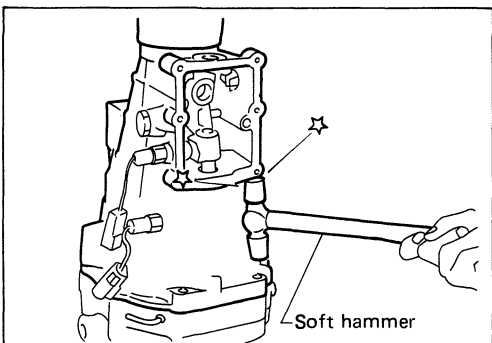

Case Components (Cont'd)

5. Remove front cover and gasket.

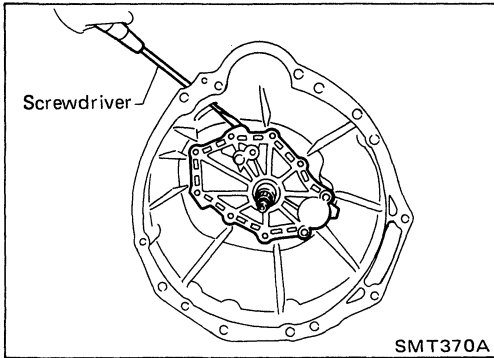

6. Remove stopper ring and main drive bearing snap ring.

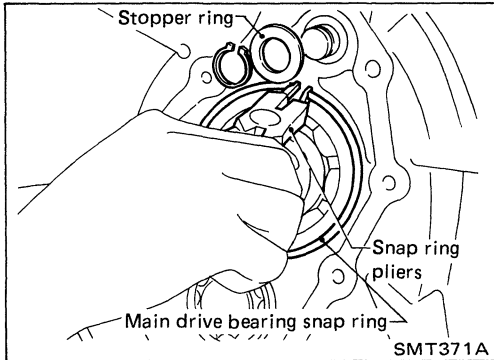

7. Remove transmission case by tapping lightly.

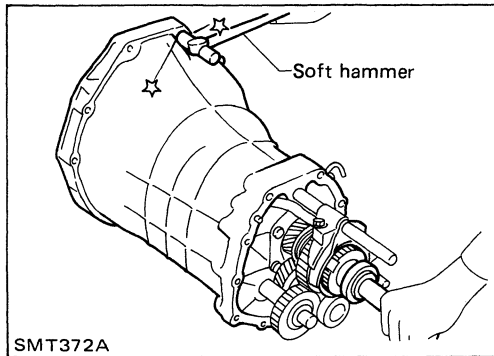

8. Remove front cover oil seal.

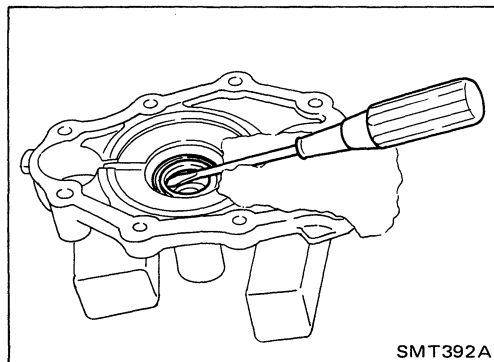

Shift Control Components

1. Mount adapter plate on vise.
2. Remove O.D. & reverse fork rod.

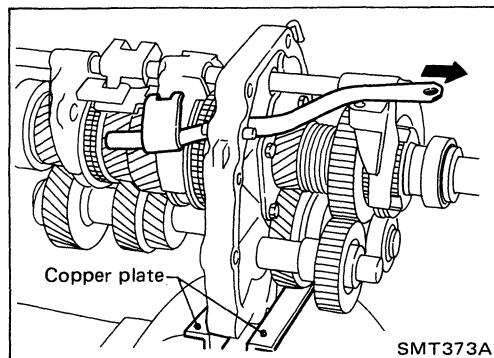

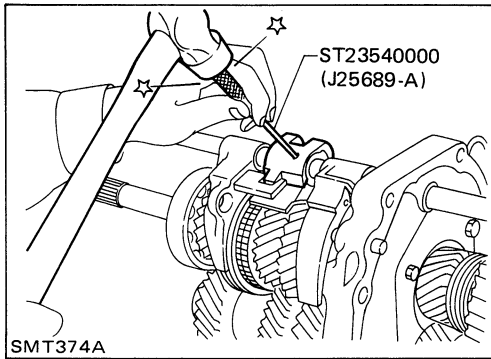
Shift Control Components (Cont'd)

3. Drive out retaining pin from striking lever.
4. While pulling out striking rod, remove striking lever and striking interlock. Then remove 1st & 2nd, 3rd & 4th and reverse shift fork.

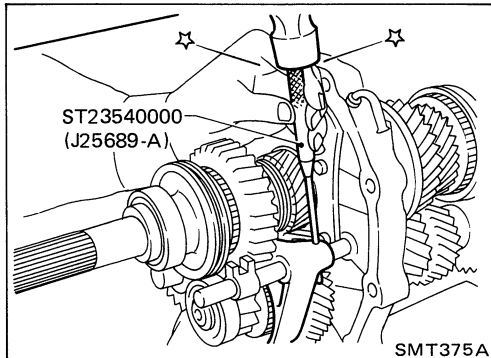

5. Drive out retaining pin from O.D. shift fork.
6. Pull out O.D. fork rod and then remove O.D. shift fork.

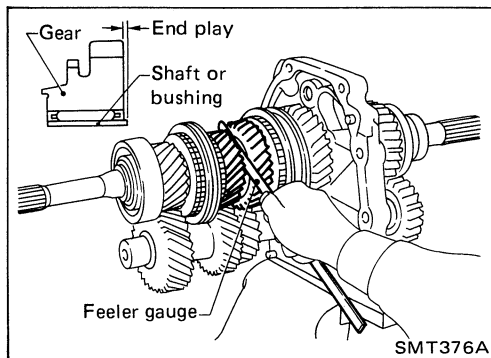
**Gear Components**

1. Before removing gears and shafts, measure each gear end play.

Gear	End play mm (in)
1st main gear	0.23 - 0.33 (0.0091 - 0.0130)
2nd main gear	0.23 - 0.33 (0.0091 - 0.0130)
3rd main gear	0.23 - 0.33 (0.0091 - 0.0130)
O.D. counter gear	0.23 - 0.33 (0.0091 - 0.0130)
Reverse main gear	0.33 - 0.43 (0.0130 - 0.0169)

- If not within specification, disassemble and check contact surface of gear to hub, washer, bushing, needle bearing and shaft.

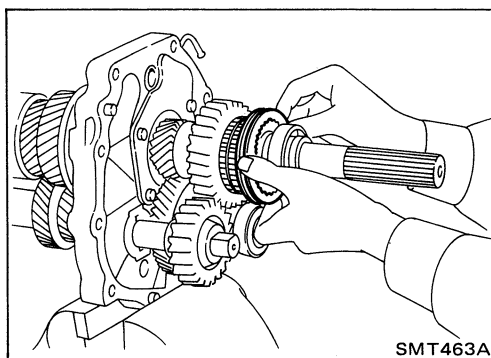

2. Remove rear side components on mainshaft and counter gear.
 - a. Remove reverse coupling sleeve.

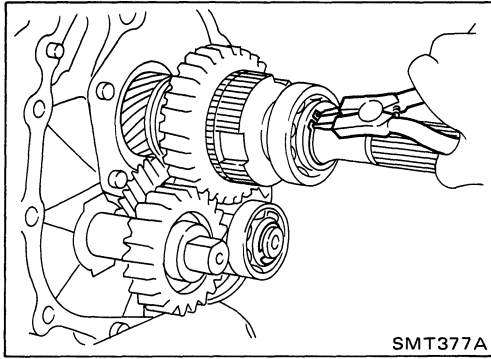
Gear Components (Cont'd)

- b. Remove mainshaft rear snap ring and counter gear rear snap ring.
- c. Remove C-ring holder and mainshaft C-rings from mainshaft. Use punch and hammer to remove C-rings.

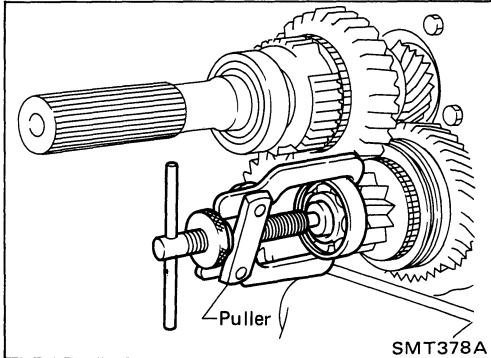

- d. Pull out counter gear rear end bearing.
- e. Remove reverse idler gear and reverse idler thrust washers.

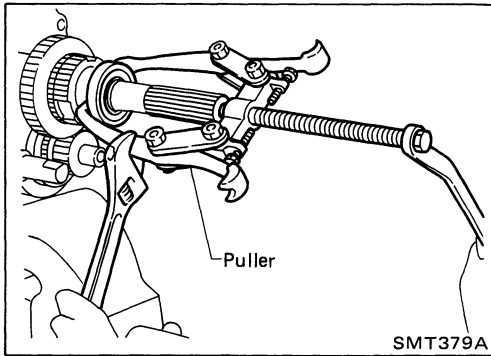

- f. Pull out mainshaft rear bearing (2WD model).

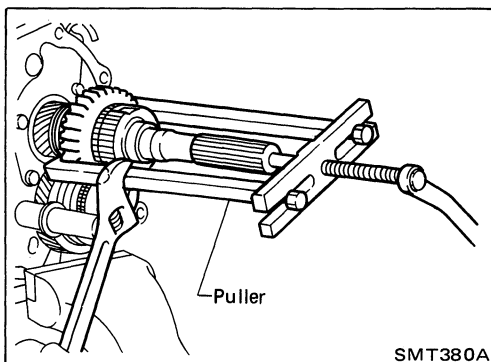

- g. Pull out reverse main gear together with mainshaft spacer and reverse synchronizer hub. Then remove reverse gear needle bearings.

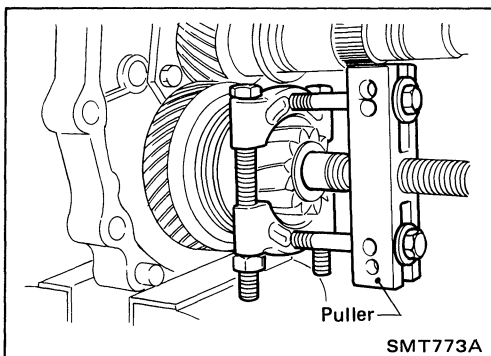

- h. Pull out reverse counter gear.
- i. Remove O.D. coupling sleeve together with O.D. baulk ring, reverse baulk ring and spring inserts.

Gear Components (Cont'd)

j. Pull out reverse gear bushing.

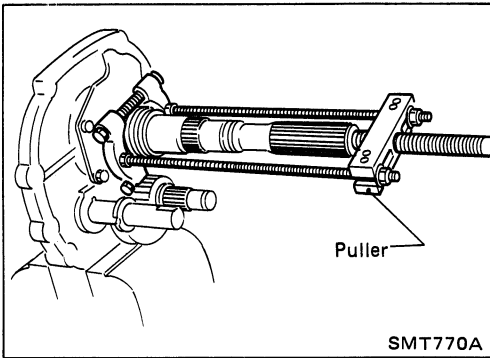

k. Pull out O.D. counter gear together with reverse cone.

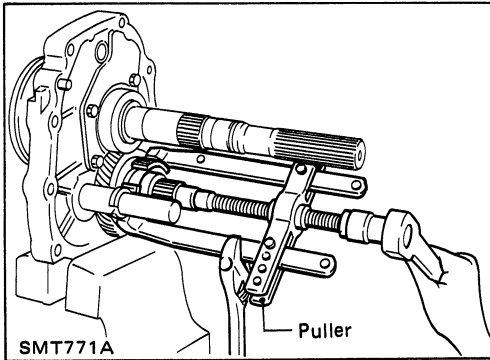

3. Press out mainshaft and counter gear alternately.

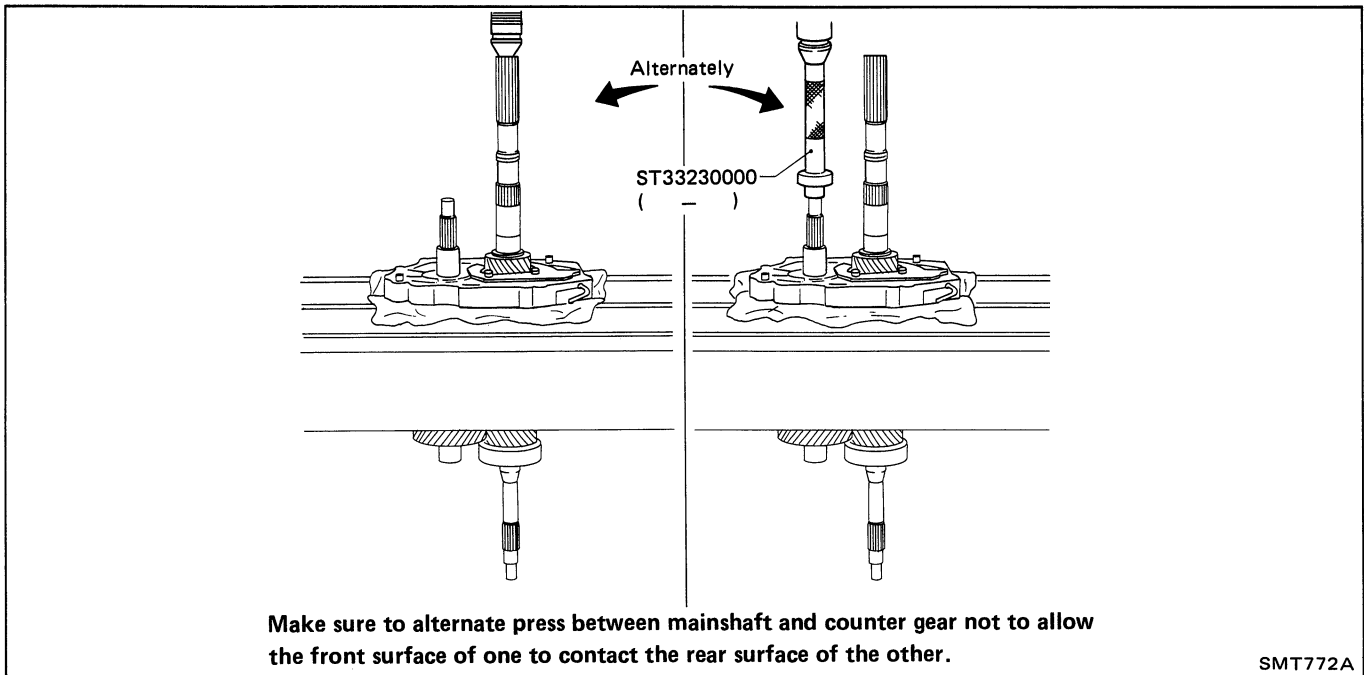

4. Remove front side components on mainshaft.

- a. Remove 1st gear washer and steel ball.
- b. Remove 1st main gear and 1st gear needle bearing.

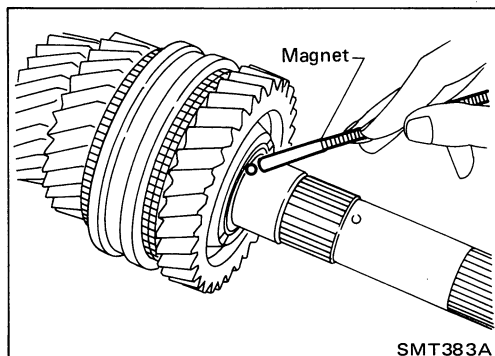

Gear Components (Cont'd)

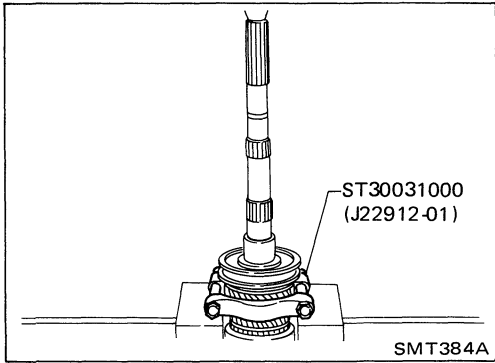

- c. Press out 2nd main gear together with 1st gear bushing and 1st & 2nd synchronizer assembly.
- d. Remove mainshaft front snap ring.

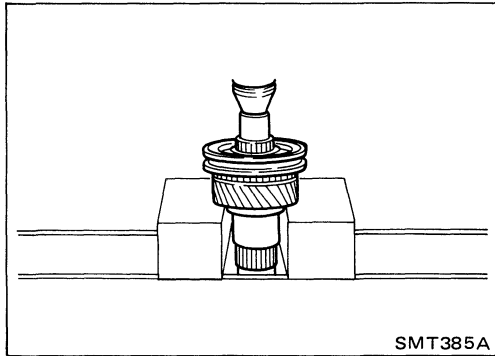

- e. Press out 3rd main gear together with 3rd & 4th synchronizer assembly and 3rd gear needle bearing.

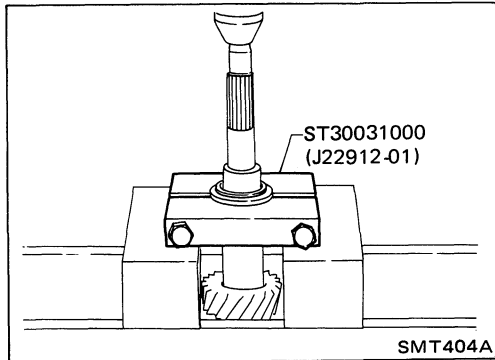

- 5. Remove front side components on counter gear.
 - a. Remove counter gear rear thrust bearing.

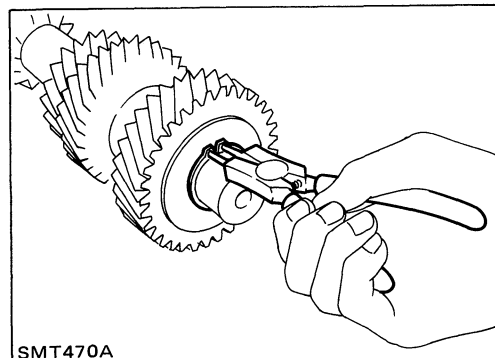

- b. Remove sub gear components.

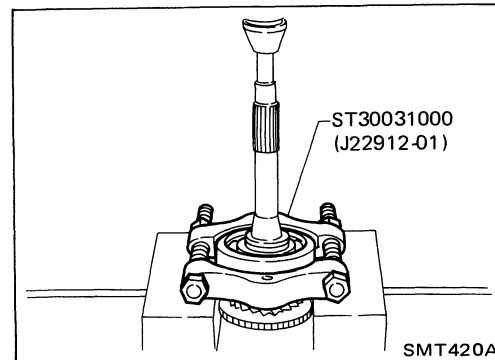

- 6. Remove main drive gear bearing.
 - a. Remove main drive gear snap ring and spacer.
 - b. Press out main drive gear bearing.

Gear Components (Cont'd)

7. Remove bearings from case components.

Counter gear front bearing in transmission case

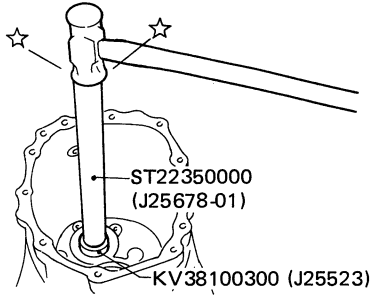

SMT388A

Mainshaft front bearing in adapter plate

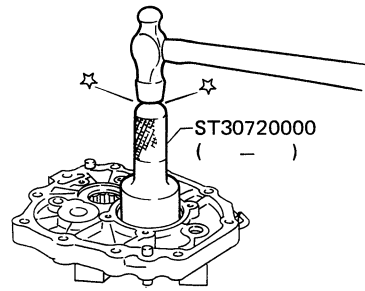

SMT396A

Counter gear rear end bearing in O.D. gear case (4WD model)

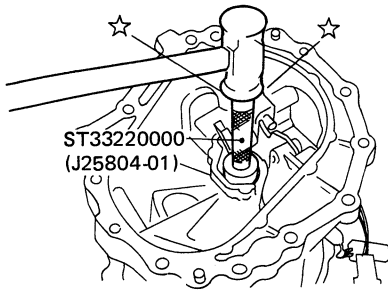

SMT390A

Counter gear rear bearing in adapter plate

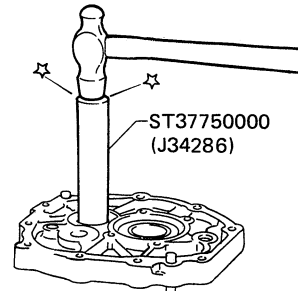

SMT394A

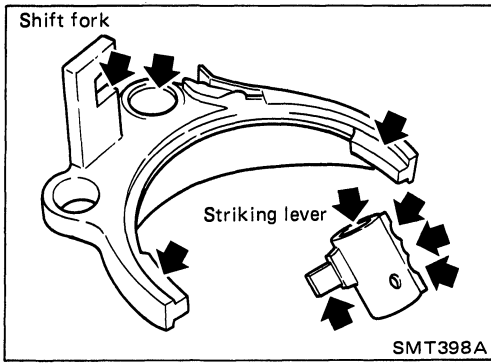

Shift Control Components

- Check contact surface and sliding surface for wear, scratches, projections or other damage.

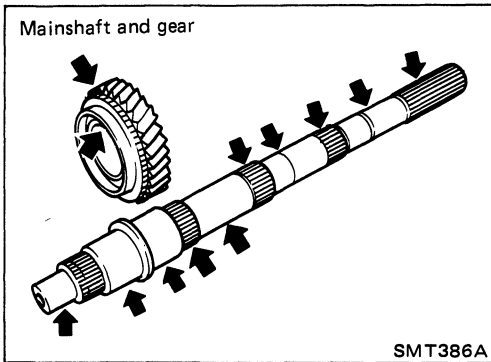

Gear Components

GEARS AND SHAFTS

- Check shafts for cracks, wear or bending.
- Check gears for excessive wear, chips or cracks.

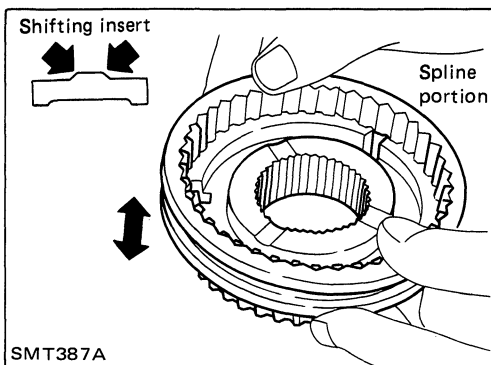
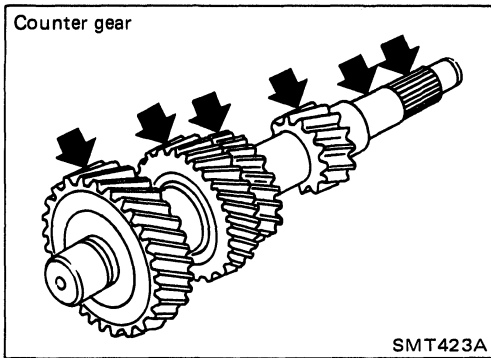

SYNCHRONIZERS

- Check spline portion of coupling sleeves, hubs, and gears for wear or cracks.
- Check baulk rings for cracks or deformation.
- Check shifting inserts for wear or deformation.
- Check insert springs for deformation.

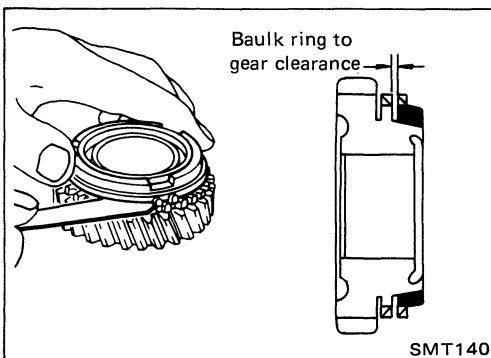

Clearance between baulk ring and gear

Unit: mm (in)

	Standard	Wear limit
1st & 2nd	1.05 - 1.3 (0.0413 - 0.0512)	0.7 (0.028)
3rd & main drive	1.05 - 1.3 (0.0413 - 0.0512)	0.7 (0.028)
O.D.	1.05 - 1.3 (0.0413 - 0.0512)	0.7 (0.028)

If the clearance is smaller than the wear limit, replace baulk ring.

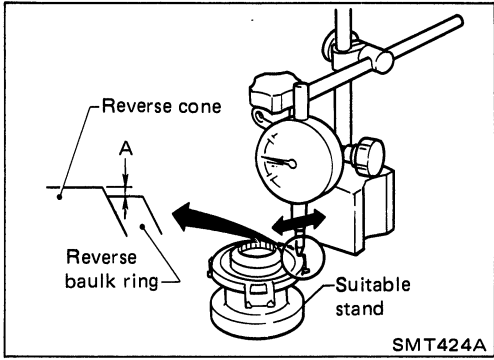

Gear Components (Cont'd)

- Measure wear of reverse baulk ring.
- a. Place baulk ring in position on reverse cone.
- b. While holding baulk ring against reverse cone as far as it will go, measure dimension "A" with dial indicator.

Unit: mm (in)

	Standard	Wear limit
Dimension "A"	-0.1 to 0.35 (-0.0039 to 0.0138)	0.7 (0.028)

- c. If dimension "A" is larger than the wear limit, replace baulk ring.

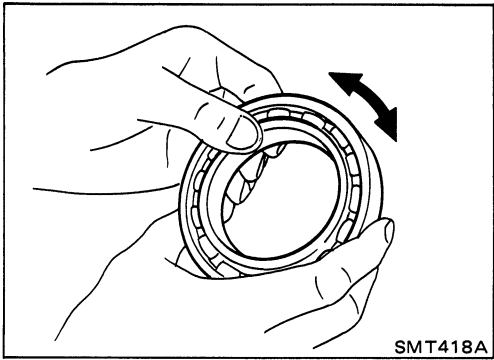

BEARINGS

- Make sure bearings roll freely and are free from noise, crack, pitting or wear.

Gear Components

1. Install bearings into case components.

Counter gear front bearing in transmission case

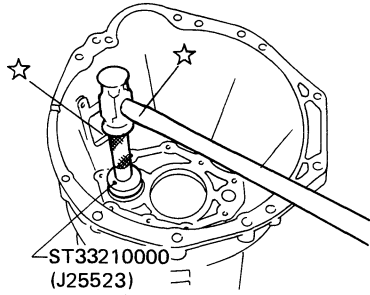

SMT389A

Mainshaft front bearing in adapter plate

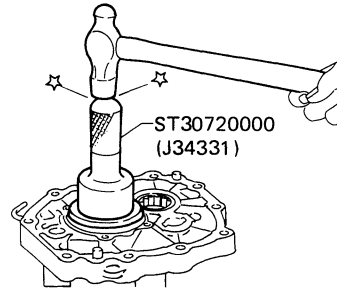

SMT397A

Counter gear rear end bearing in O.D. gear case (4WD model)

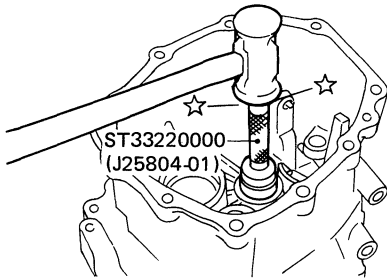

SMT391A

Counter gear rear bearing in adapter plate

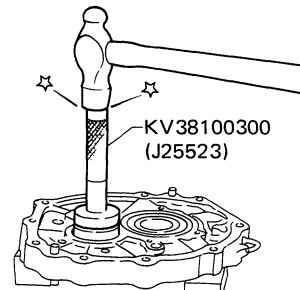

SMT395A

Be flush with front surface of O.D. gear case.

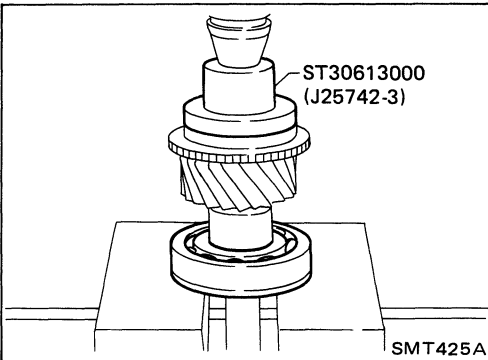

SMT425A

2. Install main drive gear bearing.

- a. Press main drive gear bearing.
- b. Install main drive gear spacer.

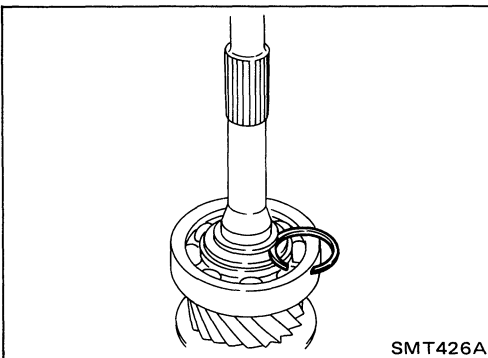

SMT426A

- c. Select proper main drive gear snap ring to minimize clearance of groove.

Allowable clearance of groove:

0 - 0.1 mm (0 - 0.004 in)

Main drive gear snap ring

Thickness mm (in)	Part number
1.89 (0.0744)	32204-01G00
1.98 (0.0780)	32204-01G01
2.05 (0.0807)	32204-01G02
2.12 (0.0835)	32204-01G03
2.19 (0.0862)	32204-01G04

- d. Install selected snap ring on main drive gear.

Gear Components (Cont'd)

3. Install components on counter gear.

a. Install sub-gear components.

When installing sub-gear snap ring, tap sub-gear snap ring into position on counter gear.

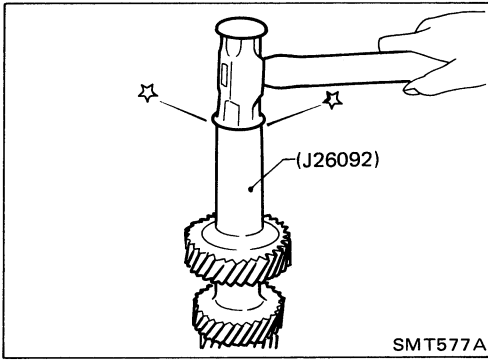

b. Install counter gear rear thrust bearing.

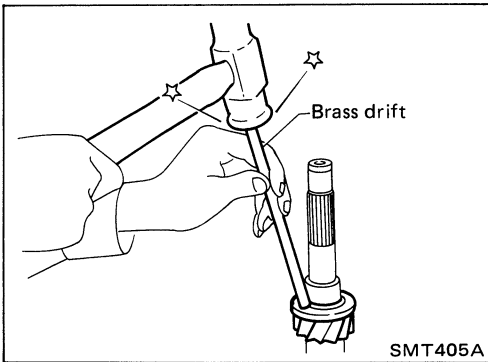

4. Install front side components on mainshaft.

a. Assemble 1st & 2nd synchronizer.

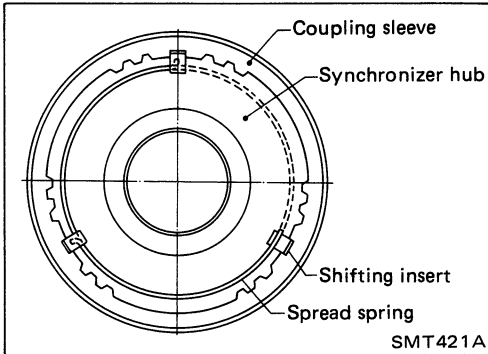

b. Assemble 3rd & 4th synchronizer.

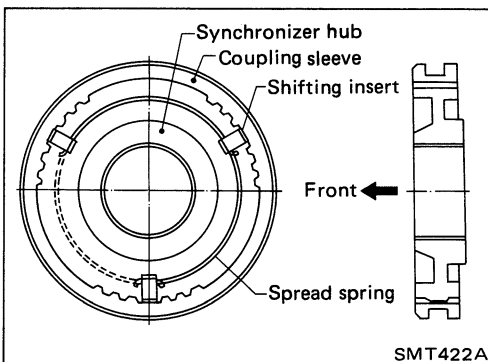

c. Press on 3rd & 4th synchronizer assembly together with 3rd main gear and 3rd gear needle bearing.

Pay attention to direction of synchronizer assembly.

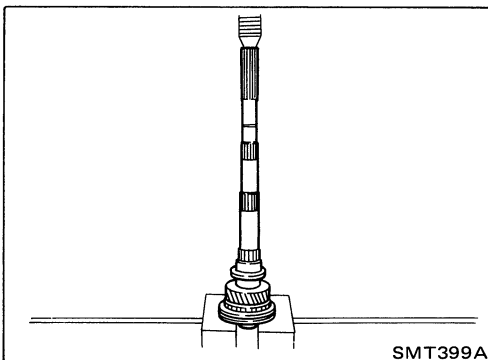

Gear Components (Cont'd)

d. Select proper snap ring to minimize clearance of groove.

Allowable clearance of groove:

0 - 0.1 mm (0 - 0.004 in)

Mainshaft front snap ring

Thickness mm (in)	Part number
1.89 (0.0744)	32204-01G00
1.98 (0.0780)	32204-01G01
2.05 (0.0807)	32204-01G02
2.12 (0.0835)	32204-01G03
2.19 (0.0862)	32204-01G04

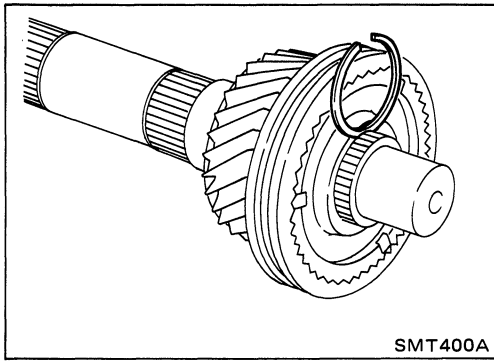

e. Install selected snap ring on mainshaft.

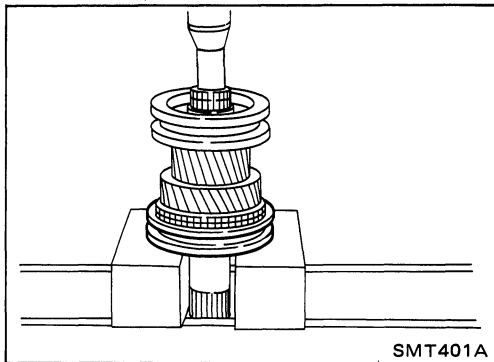

f. Press on 1st & 2nd synchronizer assembly together with 2nd main gear and 2nd gear needle bearing.

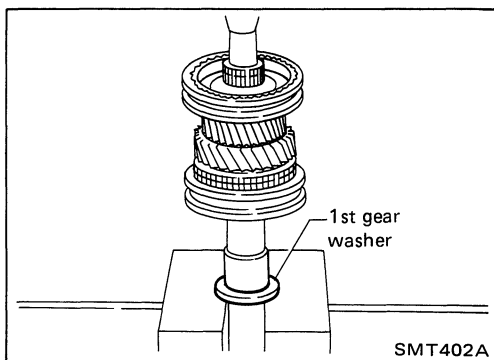

g. Press on 1st gear bushing using 1st gear washer.

h. Install 1st main gear and needle bearing.

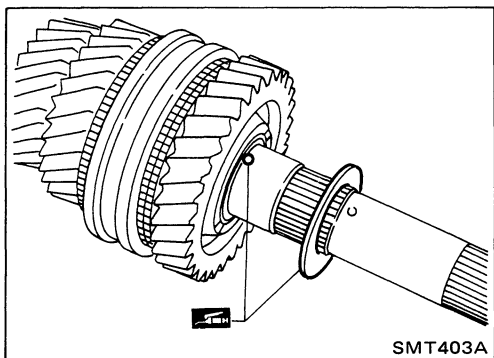

i. Install steel ball and 1st gear washer.

Apply multi-purpose grease to steel ball and 1st gear washer before installing.

Gear Components (Cont'd)

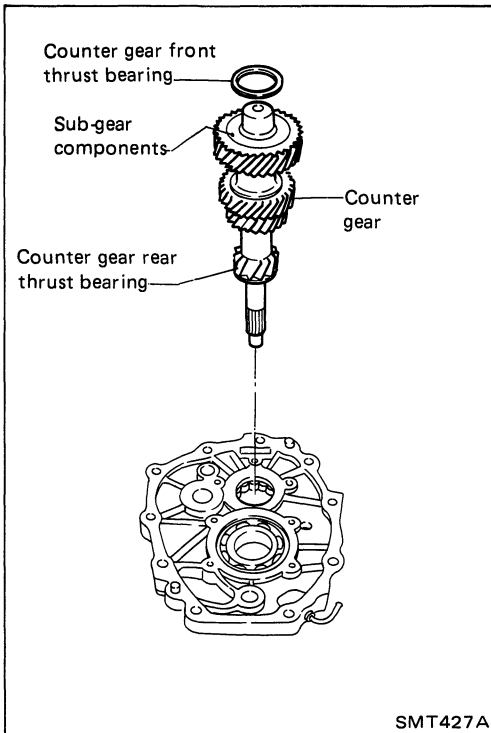

SMT427A

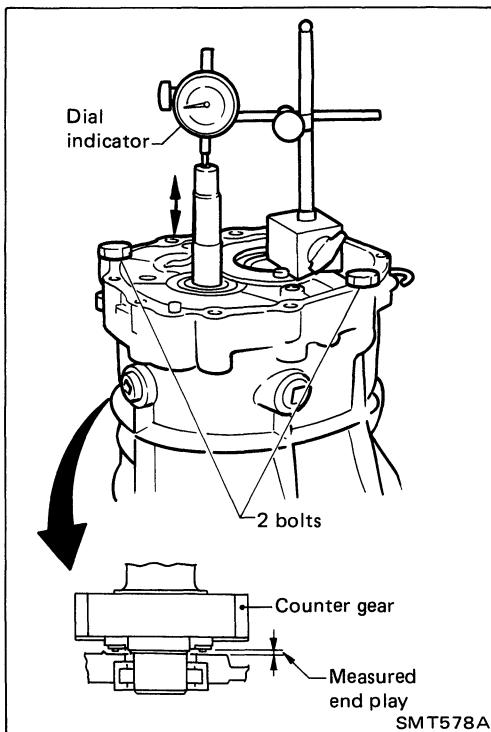

SMT578A

5. Select proper counter gear front bearing shim when replacing transmission case, counter gear, counter gear thrust bearing or sub-gear components.
 - a. Install counter gear with sub-gear components, counter gear front and rear thrust bearing on adapter plate.
 - b. Remove counter gear front bearing shim from transmission case.
 - c. Place adapter plate and counter gear assembly in transmission case (case inverted).
 - d. Tighten adapter plate to transmission case using 2 bolts.
 - e. Place dial indicator on rear end of counter gear.
 - f. Move counter gear up and down and measure dial indicator deflection.
 - g. Select proper shim using table below as a guide.

Counter gear end play:

0.10 - 0.25 mm (0.0039 - 0.0098 in)

Table for selecting proper counter gear front bearing shim

Dial indicator deflection mm (in)	Thickness of proper washer mm (in)	Part number
0.93 - 1.02 (0.0366 - 0.0402)	0.88 (0.0346)	32218-01G11
1.03 - 1.12 (0.0406 - 0.0441)	0.96 (0.0378)	32218-01G12
1.13 - 1.22 (0.0445 - 0.0480)	1.04 (0.0409)	32218-01G13
1.23 - 1.32 (0.0484 - 0.0520)	1.12 (0.0441)	32218-01G14
1.33 - 1.42 (0.0524 - 0.0559)	1.28 (0.0504)	32218-01G15
1.43 - 1.52 (0.0563 - 0.0598)	1.36 (0.0535)	32218-01G16
1.53 - 1.62 (0.0602 - 0.0638)	1.44 (0.0567)	32218-01G17

Gear Components (Cont'd)

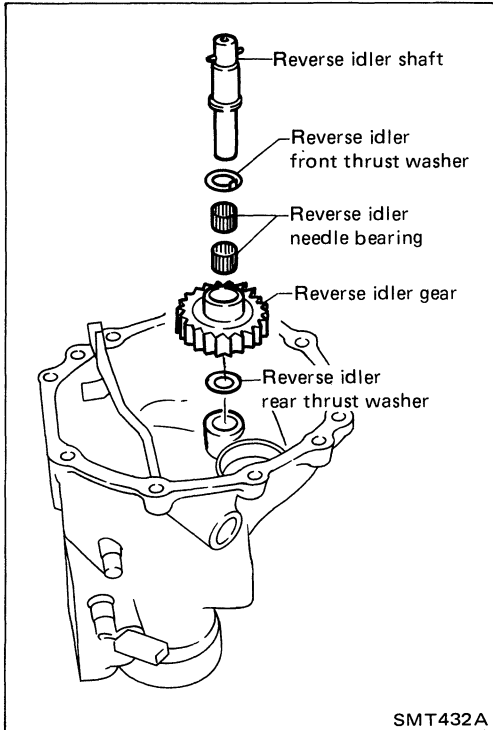

SMT432A

6. Select proper reverse idler rear thrust washer when replacing rear extension (or O.D. gear case), reverse idler gear, reverse idler shaft or reverse idler thrust washer.
 - a. Install reverse idler gear, reverse idler needle bearings, reverse idler thrust washers and reverse idler shaft into rear extension (or O.D. gear case).

When replacing reverse idler rear washer, install either A or B.

Reverse idler rear thrust washer

	Thickness mm (in)	Part number
A	1.97 (0.0776)	32284-01G10
B	2.07 (0.0815)	32284-01G11

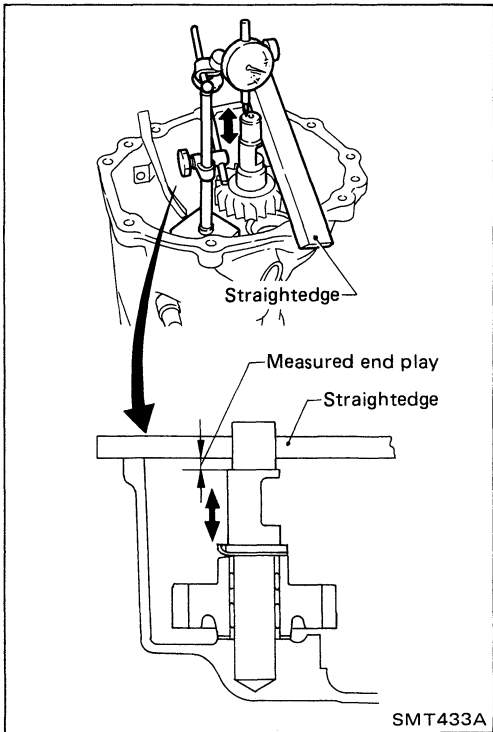

SMT433A

- b. Place dial indicator on front end of reverse idler shaft.
- c. Put straightedge on front surface of rear extension (or O.D. gear case) as a stopper of reverse idler shaft.
- d. Move reverse idler shaft up and down and measure reverse idler gear end play.

Reverse idler gear end play:

0.30 - 0.53 mm (0.0118 - 0.0209 in)

- e. If not within specification, replace reverse idler rear thrust washer with the other (A or B) and check again.

Gear Components (Cont'd)

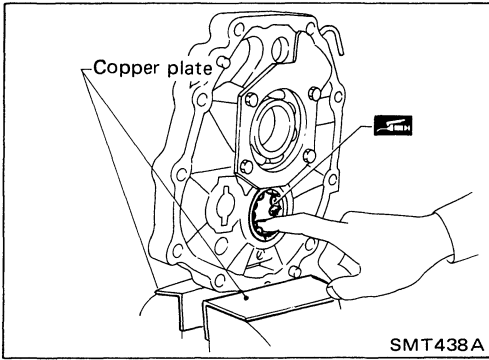

7. Install mainshaft and counter gear on adapter plate and main drive gear on mainshaft.
 - a. Mount adapter plate on vise and apply multi-purpose grease to counter gear rear bearing.

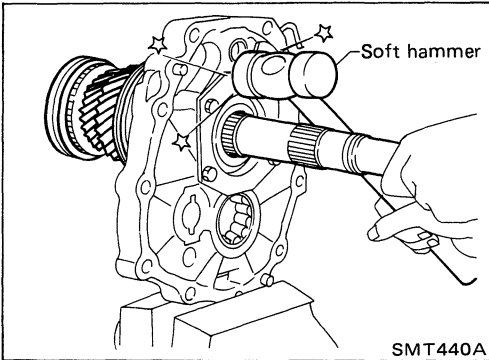

- b. Install mainshaft a little on mainshaft front bearing. **To allow for installation of counter gear, do not install mainshaft completely.**

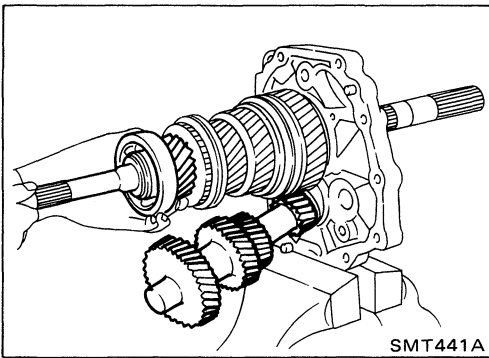

- c. Install counter gear on counter gear rear bearing and install main drive gear, pilot bearing and spacer on mainshaft.

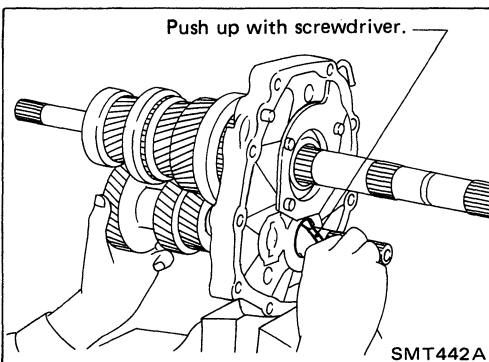

When installing counter gear into counter gear rear bearing, push up on upper roller of counter gear rear bearing with screwdriver.

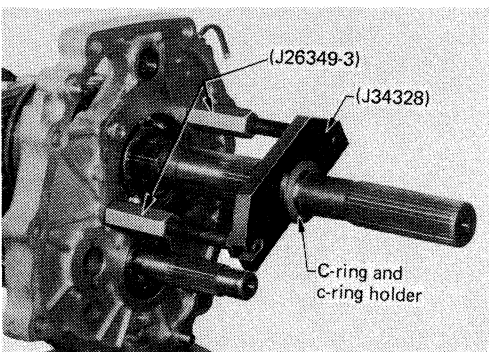

- d. Install Tools (J26349-3) onto adapter plate and C-ring and C-ring holder on mainshaft.
 - e. Install Tool (J34328) on mainshaft.

Gear Components (Cont'd)

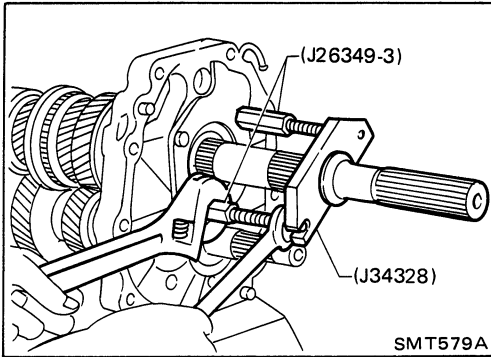

f. Install mainshaft and counter gear completely by extending length of J26349-3.

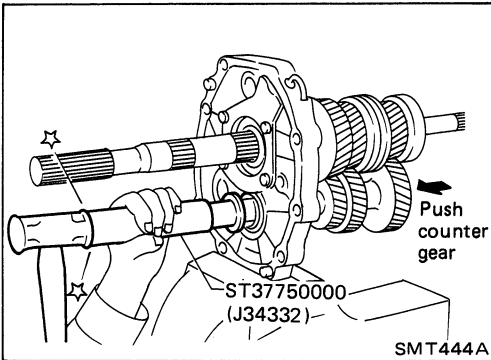

8. Install rear side components on mainshaft and counter gear.
a. Install O.D. gear bushing while pushing on the front of counter gear.

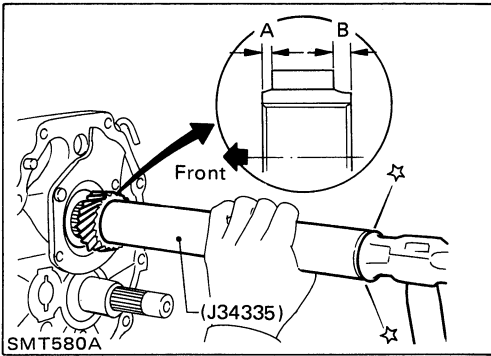

b. Install O.D. main gear.
Pay attention to direction of O.D. main gear. (B is wider than A as shown at left.)
c. Install adapter plate with gear assembly onto transmission case.
d. Install O.D. gear needle bearing and then install O.D. counter gear and reverse idler shaft.

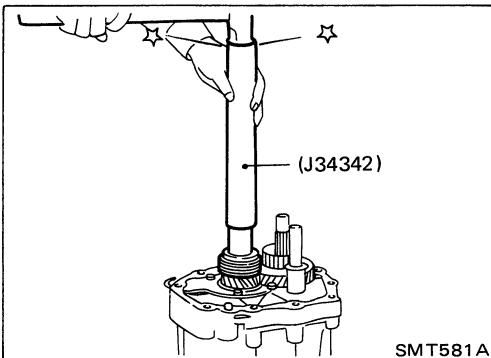

e. Install reverse gear bushing with speedometer drive gear (2WD model).

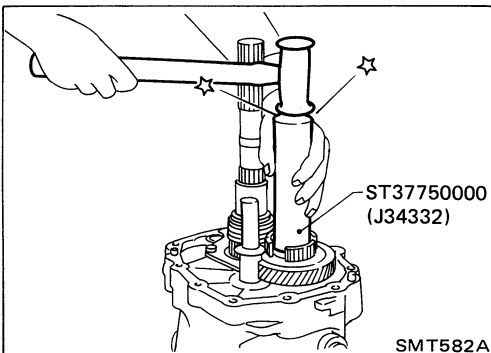

f. Install reverse cone.

Gear Components (Cont'd)

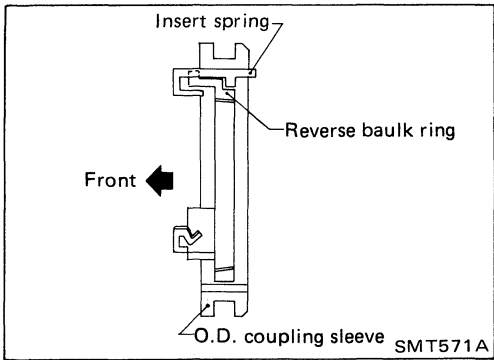

- g. Install insert springs and reverse baulk ring on O.D. coupling sleeve. Then install them and O.D. baulk ring on O.D. counter gear.
Pay attention to direction of O.D. coupling sleeve.

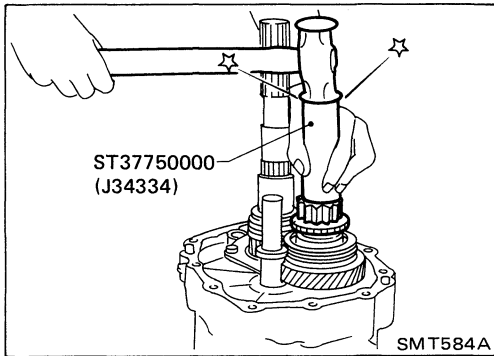
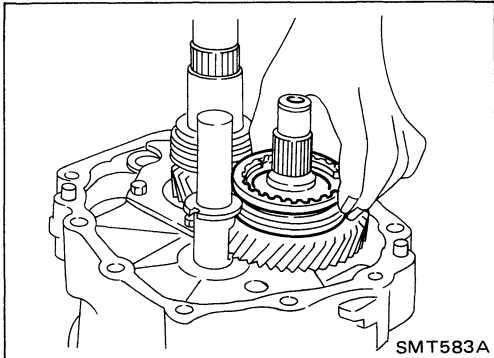

- h. Install reverse counter gear.
- i. Install reverse gear needle bearing and then install reverse main gear, reverse idler gear and reverse idler thrust washers.

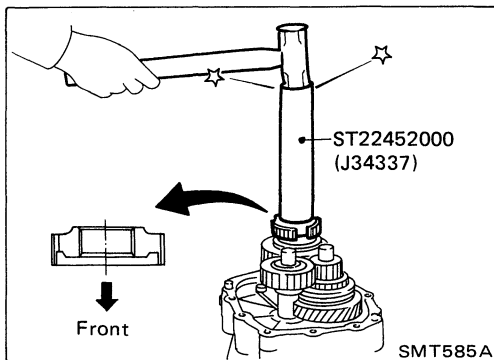

- j. Install reverse hub.
Pay attention to its direction.

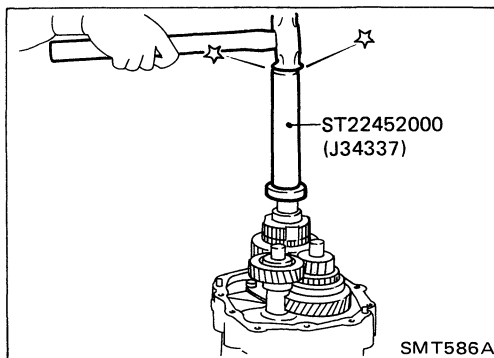

- k. Install mainshaft spacer and mainshaft rear bearing (2WD model).

Gear Components (Cont'd)

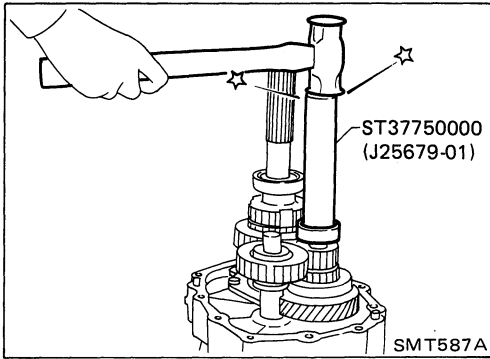

- l. Install counter gear rear end bearing.
- m. Separate adapter plate from transmission case and Mount adapter plate on vice again.

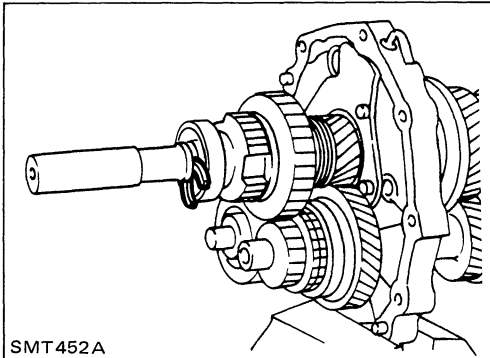

- n. Select proper mainshaft C-ring to minimize clearance of groove.

**Allowable clearance of groove:
0 - 0.1 mm (0 - 0.004 in)**

Mainshaft C-ring

Thickness mm (in)	Part number	Thickness mm (in)	Part number
2.63 (0.1035)	32348-01G15	3.19 (0.1256)	32348-01G07
2.70 (0.1063)	32348-01G00	3.26 (0.1283)	32348-01G08
2.77 (0.1091)	32348-01G01	3.33 (0.1311)	32348-01G09
2.84 (0.1118)	32348-01G02	3.40 (0.1339)	32348-01G10
2.91 (0.1146)	32348-01G03	3.47 (0.1366)	32348-01G11
2.98 (0.1173)	32348-01G04	3.54 (0.1394)	32348-01G12
3.05 (0.1201)	32348-01G05	3.61 (0.1421)	32348-01G13
3.12 (0.1228)	32348-01G06	3.68 (0.1449)	32348-01G14

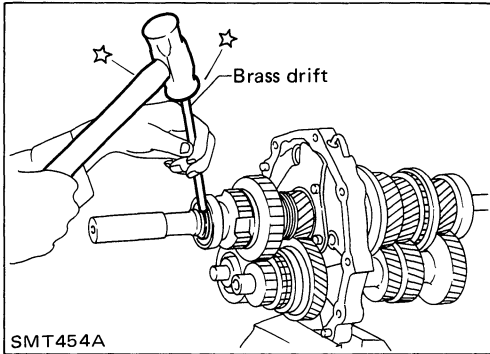

- o. Install selected C-ring, C-ring holder and mainshaft rear snap ring.

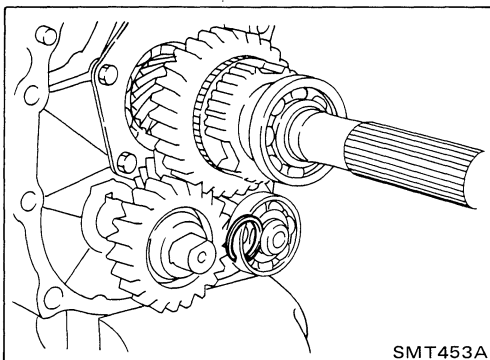

- p. Install spacer and then select proper counter gear rear snap ring to minimize clearance of groove.

**Allowable clearance of groove:
0 - 0.1 mm (0 - 0.004 in)**

Counter gear rear snap ring

Thickness mm (in)	Part number
1.26 (0.0496)	32236-01G08
1.32 (0.0520)	32236-01G00
1.38 (0.0543)	32236-01G01
1.44 (0.0567)	32236-01G02
1.50 (0.0591)	32236-01G03
1.56 (0.0614)	32236-01G04
1.62 (0.0638)	32236-01G05
1.68 (0.0661)	32236-01G06
1.74 (0.0685)	32236-01G07

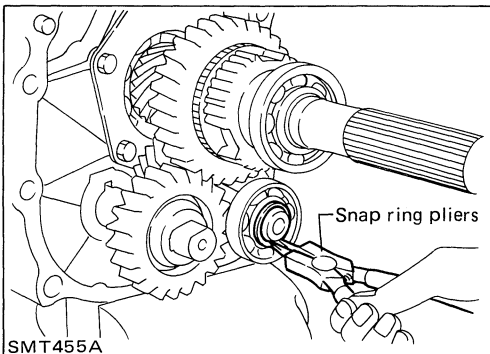

- q. Install selected counter gear rear snap ring.

Gear Components (Cont'd)

- r. Install reverse coupling sleeve.
Pay attention to its direction.
- s. Measure each gear end play as a final check – Refer to "DISASSEMBLY".

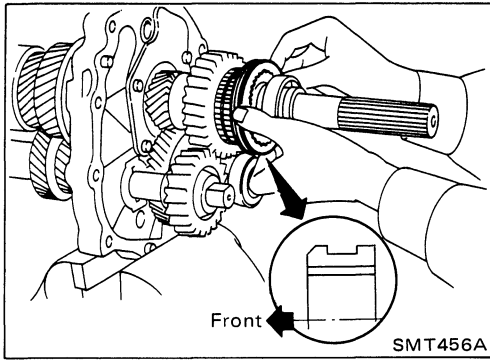

Shift Control Components

1. Install O.D. fork rod and O.D. shift fork. Then install retaining pin into O.D. shift fork.
2. Install 1st & 2nd, 3rd & 4th and reverse shift fork onto coupling sleeve.
3. Install striking rod into hole of shift forks, striking lever and interlock and then install retaining pin into striking lever.
Make sure that striking rod moves smoothly.

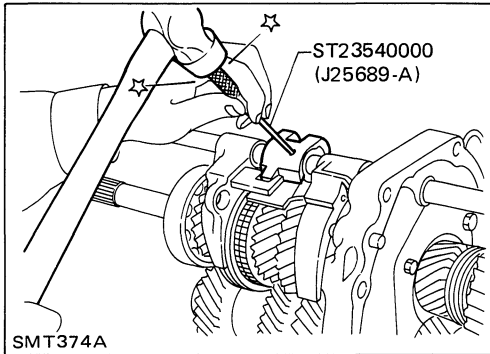
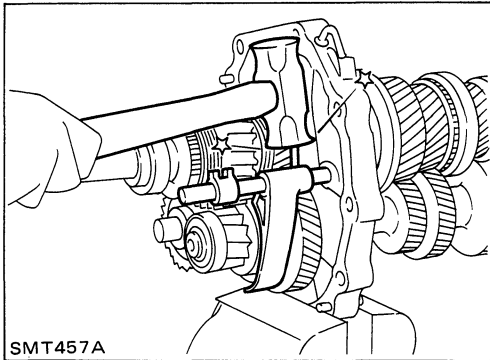

Case Components

1. Install front cover oil seal.
Apply multi-purpose grease to seal lip.
2. Install selected counter gear front bearing shim onto transmission case.
Apply multi-purpose grease.
3. Apply sealant to mating surface of transmission case.
4. Install gear assembly onto transmission case.
5. Install check spring and check ball into interlock stopper.
Apply multi-purpose grease to check ball.

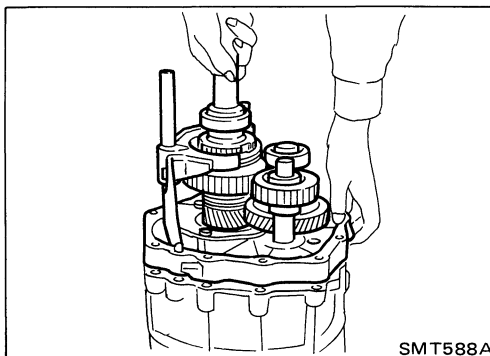
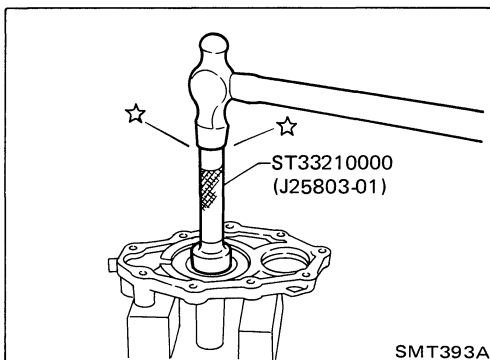

Case Components (Cont'd)

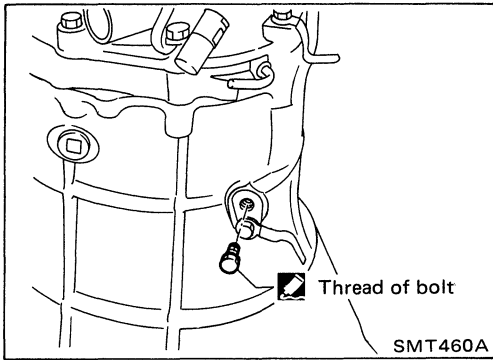

6. Install interlock stopper assembly and then tighten check ball plug.

Apply sealant to thread of check ball plug.

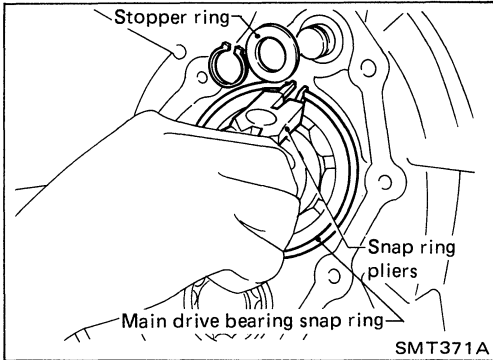

7. Install stopper ring and main drive bearing snap ring.

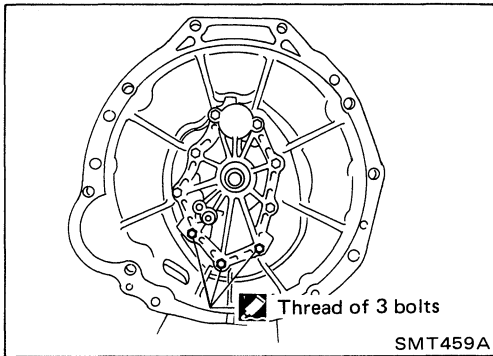

8. Install front cover and gasket.

Apply sealant to thread of 3 bolts shown left.

9. Apply sealant to mating surface of adapter plate.

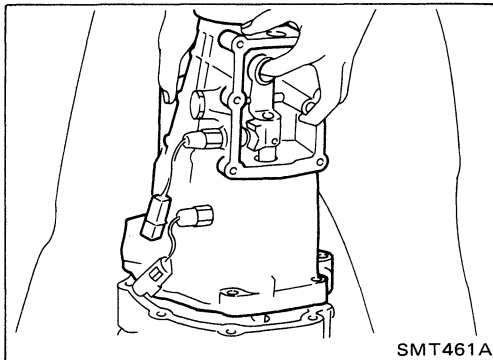

10. Install rear extension (or O.D. gear case) together with striking arm.

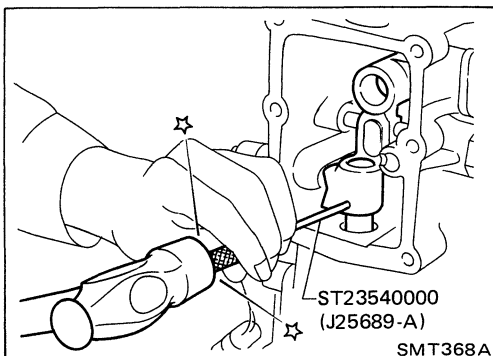

11. Install retaining pin into striking arm.

Case Components (Cont'd)

12. Install return spring and check ball and then install control housing.

Apply sealant to mating surface of rear extension (or O.D. gear case).

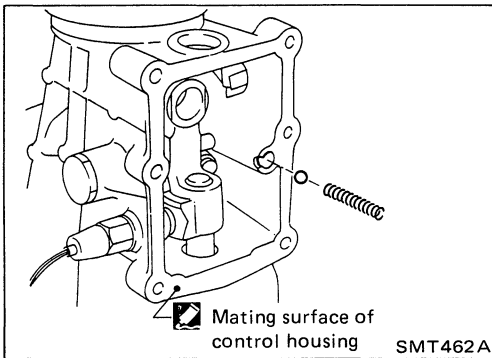

13. Tighten control housing bolts.

Bolt head size:

A bolts 12 mm

B bolts 13 mm

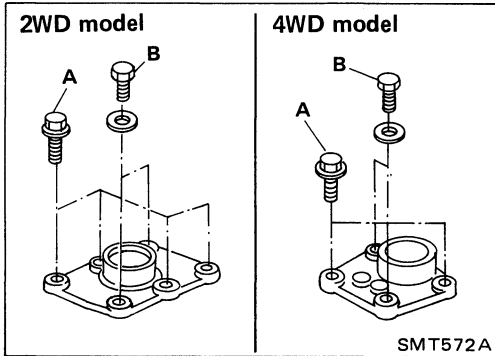

SERVICE DATA AND SPECIFICATIONS (S.D.S.)

General Specifications

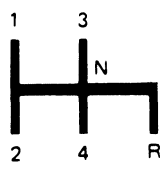
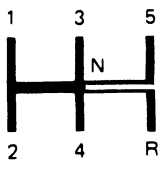
Vehicle model	2WD		4WD		2WD	4WD
Transmission model	F4W71C	FS5W71C			FS5R30A	
Engine	Z24i				VG30i	
No. of speeds	4		5			
Shift pattern						
Synchromesh type	Warner					
Gear ratio						
1st	3.321	3.321	3.592	3.985	3.580	4.061
2nd	1.902	1.902	2.246	2.246	2.077	2.357
3rd	1.308	1.308	1.415	1.415	1.360	1.490
4th	1.000	1.000	1.000	1.000	1.000	1.000
O.D.	—	0.838	0.821	0.821	0.811	0.862
Reverse	3.382	3.382	3.657	3.657	3.636	4.125
No. of teeth						
Mainshaft						
Drive	22	22	21	21	22	20
1st	33	33	33	34	32	32
2nd	27	27	28	28	30	30
3rd	26	26	26	26	29	28
O.D.	—	22	21	21	24	23
Reverse	36	36	36	36	30	30
Countershaft						
Drive	31	31	32	32	32	33
1st	14	14	14	13	13	13
2nd	20	20	19	19	21	21
3rd	28	28	28	28	31	31
O.D.	—	37	39	39	43	44
Reverse	15	15	15	15	12	12
Reverse idler gear	21	21	21	21	22	22
Oil capacity ℓ (US pt, Imp pt)	1.7 (3-5/8, 3)	2.0 (4-1/4, 3-1/2)	4.0 (8-1/2, 7)		2.4 (5-1/8, 4-1/4)	3.6 (7-5/8, 6-3/8)

**Inspection and Adjustment –
FS5W71C and F4W71C**

GEAR END PLAY

Unit: mm (in)

	FS5W71C	F4W71C
1st gear	0.31 - 0.41 (0.0122 - 0.0161)	0.31 - 0.41 (0.0122 - 0.0161)
2nd gear	0.11 - 0.21 (0.0043 - 0.0083)	0.11 - 0.21 (0.0043 - 0.0083)
3rd gear	0.11 - 0.21 (0.0043 - 0.0083)	0.11 - 0.21 (0.0043 - 0.0083)
O.D. gear	0.24 - 0.41 (0.0094 - 0.0161)	—

**CLEARANCE BETWEEN BAULK RING
AND GEAR**

Unit: mm (in)

	FS5W71C	F4W71C
Standard		
1st & 2nd	1.20 - 1.60 (0.0472 - 0.0630)	1.20 - 1.60 (0.0472 - 0.0630)
3rd & main drive	1.20 - 1.60 (0.0472 - 0.0630)	1.20 - 1.60 (0.0472 - 0.0630)
O.D.	1.20 - 1.60 (0.0472 - 0.0630)	—
Wear limit		
1st & 2nd	0.80 (0.0315)	0.80 (0.0315)
3rd & main drive	0.80 (0.0315)	0.80 (0.0315)
O.D.	0.80 (0.0315)	—

AVAILABLE SNAP RINGS

Main drive gear bearing

Allowable clearance	0 - 0.13 mm (0 - 0.0051 in)	
Thickness mm (in)	Part number	
1.73 (0.0681)	32204-78005	
1.80 (0.0709)	32204-78000	
1.87 (0.0736)	32204-78001	
1.94 (0.0764)	32204-78002	
2.01 (0.0791)	32204-78003	
2.08 (0.0819)	32204-78004	

Mainshaft front

Allowable clearance	0 - 0.18 mm (0 - 0.0071 in)	
Thickness mm (in)	Part number	
2.4 (0.094)	32263-V5200	
2.5 (0.098)	32263-V5201	
2.6 (0.102)	32263-V5202	

**Mainshaft rear end bearing
(FS5W71C 2WD model)**

Allowable clearance	0 - 0.14 mm (0 - 0.0055 in)	
Thickness mm (in)	Part number	
1.1 (0.043)	32228-20100	
1.2 (0.047)	32228-20101	
1.3 (0.051)	32228-20102	
1.4 (0.055)	32228-20103	

Counter drive gear

Allowable clearance	0 - 0.18 mm (0 - 0.0071 in)	
Thickness mm (in)	Part number	
1.4 (0.055)	32215-E9000	
1.5 (0.059)	32215-E9001	
1.6 (0.063)	32215-E9002	

Counter reverse gear (F4W71C)

Allowable clearance	0 - 0.18 mm (0 - 0.0071 in)	
Thickness mm (in)	Part number	
1.4 (0.055)	32228-E9200	
1.5 (0.059)	32228-E9201	
1.6 (0.063)	32228-E9202	

AVAILABLE SHIMS

Counter front bearing

Unit: mm (in)

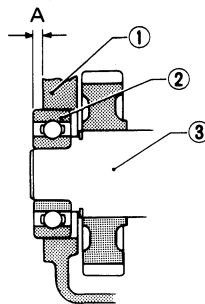

A: Distance from bearing surface to transmission case

- 1 Transmission case
- 2 Counter gear front bearing
- 3 Counter gear

TM371

"A"	Thickness of shim	Part number
4.52 - 4.71 (0.1780 - 0.1854)	Not necessary	
4.42 - 4.51 (0.1740 - 0.1776)	0.1 (0.004)	32218-V5000
4.32 - 4.41 (0.1701 - 0.1736)	0.2 (0.008)	32218-V5001
4.22 - 4.31 (0.1661 - 0.1697)	0.3 (0.012)	32218-V5002
4.12 - 4.21 (0.1622 - 0.1657)	0.4 (0.016)	32218-V5003
4.02 - 4.11 (0.1583 - 0.1618)	0.5 (0.020)	32218-V5004
3.92 - 4.01 (0.1543 - 0.1579)	0.6 (0.024)	32218-V5005

Tightening Torque – FS5W71C and F4W71C

TRANSMISSION INSTALLATION

Unit	N·m	kg·m	ft·lb
Clutch operating cylinder	30 - 40	3.1 - 4.1	22 - 30
Transmission securing bolt	Refer to removal and Installation.		
Crossmember to frame	Refer to EM section.		
Rear mounting insulator to rear extension	Refer to EM section.		
Starter motor fixing bolt	Refer to EM section.		

GEAR ASSEMBLY

Unit	N·m	kg·m	ft·lb
Rear extension to transmission case	16 - 20	1.6 - 2.0	12 - 14
Front cover to transmission case	16 - 21	1.6 - 2.1	12 - 15
Control housing to rear extension	14 - 18	1.4 - 1.8	10 - 13
Ball pin	20 - 34	2.0 - 3.5	14 - 25
Filler plug	25 - 34	2.5 - 3.5	18 - 25
Drain plug	25 - 34	2.5 - 3.5	18 - 25
Speedometer sleeve installation	4 - 5	0.4 - 0.5	2.9 - 3.6
Return spring plug	20 - 29	2.0 - 3.0	14 - 22
Reverse check sleeve to transmission case	4 - 5	0.4 - 0.5	2.9 - 3.6
Reverse lamp switch	20 - 29	2.0 - 3.0	14 - 22
Check ball plug	19 - 25	1.9 - 2.5	14 - 18
Mainshaft lock nut (without Tool)	137 - 167	14.0 - 17.0	101 - 123
Countershaft lock nut (FS5W71C)	98 - 127	10.0 - 13.0	72 - 94
Striking lever lock nut	9 - 12	0.9 - 1.2	6.5 - 8.7
Bearing retainer to adapter plate	19 - 25	1.9 - 2.5	14 - 18
Baffle plate fixing bolt (4WD model)	3 - 5	0.3 - 0.5	2.2 - 3.6

Inspection and Adjustment — FS5R30A

GEAR END PLAY

Gear	End play mm (in)
1st main gear	0.23 - 0.33 (0.0091 - 0.0130)
2nd main gear	0.23 - 0.33 (0.0091 - 0.0130)
3rd main gear	0.23 - 0.33 (0.0091 - 0.0130)
O.D. counter gear	0.23 - 0.33 (0.0091 - 0.0130)
Reverse main gear	0.33 - 0.43 (0.0130 - 0.0169)
Counter gear	0.10 - 0.25 (0.0039 - 0.0098)
Reverse idler gear	0.30 - 0.53 (0.0118 - 0.0209)

CLEARANCE BETWEEN BAULK RING AND GEAR

Unit: mm (in)

	Standard	Wear limit
1st & 2nd	1.05 - 1.3 (0.0413 - 0.0512)	0.7 (0.028)
3rd & main drive	1.05 - 1.3 (0.0413 - 0.0512)	0.7 (0.028)
O.D.	1.05 - 1.3 (0.0413 - 0.0512)	0.7 (0.028)

DISTANCE BETWEEN REAR SURFACE OF REVERSE CONE AND REVERSE BAULK RING

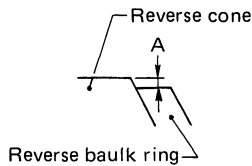

Unit: mm (in)

	Standard	Wear limit
Dimension "A"	-0.1 to 0.35 (-0.0039 to 0.0138)	0.7 (0.028)

**AVAILABLE SNAP RING
Main drive gear snap ring**

Allowable clearance 0 - 0.1 mm (0 - 0.004 in)

Thickness mm (in)	Part number
1.89 (0.0744)	32204-01G00
1.98 (0.0780)	32204-01G01
2.05 (0.0807)	32204-01G02
2.12 (0.0835)	32204-01G03
2.19 (0.0862)	32204-01G04

Mainshaft front snap ring

Allowable clearance 0 - 0.1 mm (0 - 0.004 in)

Thickness mm (in)	Part number
1.89 (0.0744)	32204-01G00
1.98 (0.0780)	32204-01G01
2.05 (0.0807)	32204-01G02
2.12 (0.0835)	32204-01G03
2.19 (0.0862)	32204-01G04

Counter gear rear snap ring

Allowable clearance 0 - 0.1 mm (0 - 0.004 in)

Thickness mm (in)	Part number
1.26 (0.0496)	32236-01G08
1.32 (0.0520)	32236-01G00
1.38 (0.0543)	32236-01G01
1.44 (0.0567)	32236-01G02
1.50 (0.0591)	32236-01G03
1.56 (0.0614)	32236-01G04
1.62 (0.0638)	32236-01G05
1.68 (0.0661)	32236-01G06
1.74 (0.0685)	32236-01G07

**AVAILABLE C-RING
Mainshaft C-ring**

Allowable clearance 0 - 0.1 mm (0 - 0.004 in)

Thickness mm (in)	Part number	Thickness mm (in)	Part number
2.63 (0.1035)	32348-01G15	3.19 (0.1256)	32348-01G07
2.70 (0.1063)	32348-01G00	3.26 (0.1283)	32348-01G08
2.77 (0.1091)	32348-01G01	3.33 (0.1311)	32348-01G09
2.84 (0.1118)	32348-01G02	3.40 (0.1339)	32348-01G10
2.91 (0.1146)	32348-01G03	3.47 (0.1366)	32348-01G11
2.98 (0.1173)	32348-01G04	3.54 (0.1394)	32348-01G12
3.05 (0.1201)	32348-01G05	3.61 (0.1421)	32348-01G13
3.12 (0.1228)	32348-01G06	3.68 (0.1449)	32348-01G14

**Inspection and Adjustment — FS5R30A
(Cont'd)**

**AVAILABLE SHIM AND WASHER
Table for selecting proper counter gear
front bearing shim**

Dial indicator deflection mm (in)	Thickness of proper washer mm (in)	Part number
0.93 - 1.02 (0.0366 - 0.0402)	0.88 (0.0346)	32218-01G11
1.03 - 1.12 (0.0406 - 0.0441)	0.96 (0.0378)	32218-01G12
1.13 - 1.22 (0.0445 - 0.0480)	1.04 (0.0409)	32218-01G13
1.23 - 1.32 (0.0484 - 0.0520)	1.12 (0.0441)	32218-01G14
1.33 - 1.42 (0.0524 - 0.0559)	1.28 (0.0504)	32218-01G15
1.43 - 1.52 (0.0563 - 0.0598)	1.36 (0.0535)	32218-01G16
1.53 - 1.62 (0.0602 - 0.0638)	1.44 (0.0567)	32218-01G17

Reverse idler rear thrust washer

Thickness mm (in)	Part number
1.97 (0.0776)	32284-01G10
2.07 (0.0815)	32284-01G11

**Tightening Torque — FS5R30A
GEAR ASSEMBLY**

TRANSMISSION INSTALLATION

Unit	N·m	kg·m	ft·lb
Clutch operating cylinder	30 - 40	3.1 - 4.1	22 - 30
Transmission securing bolt	Refer to Removal and Installation.		
Engine gusset to engine	39 - 49	4.0 - 5.0	29 - 36
Second crossmember fixing bolt	Refer to section TF.		
Rear mounting insulator to rear extension	Refer to section EM.		
Starter motor fixing bolt	Refer to section EM.		

Unit	N·m	kg·m	ft·lb
Rear extension (or O.D. gear case) to transmission case	31 - 42	3.2 - 4.3	23 - 31
Front cover to transmission case	16 - 21	1.6 - 2.1	12 - 15
Control housing to rear extension (or O.D. gear case)	16 - 21	1.6 - 2.1	12 - 15
Ball pin	31 - 42	3.2 - 4.3	23 - 31
Filler plug	25 - 34	2.5 - 3.5	18 - 25
Drain plug	25 - 34	2.5 - 3.5	18 - 25
Speedometer pinion installation	4 - 5	0.4 - 0.5	2.9 - 3.6
Interlock stopper fixing bolt	31 - 42	3.2 - 4.3	23 - 31
Check ball plug	19 - 25	1.9 - 2.6	14 - 19
Select check plug	20 - 29	2.0 - 3.0	14 - 22
Reverse check sleeve fixing bolt	6.3 - 8.3	0.64 - 0.85	4.6 - 6.1
O.D. & reverse fork rod to reverse shift fork	25 - 29	2.5 - 3.0	18 - 22
O.D. and reverse shift fork connecting bolt	29 - 34	3.0 - 3.5	22 - 25
Guide plate to rear extension (or O.D. gear case)	6.3 - 8.3	0.64 - 0.85	4.6 - 6.1
Bearing retainer to adopter plate	16 - 21	1.6 - 2.1	12 - 15
Baffle plate to O.D. gear case (4WD model)	6.3 - 8.3	0.64 - 0.85	4.6 - 6.1
Reverse lamp switch	20 - 29	2.0 - 3.0	14 - 22
Neutral switch	20 - 29	2.0 - 3.0	14 - 22

AUTOMATIC TRANSMISSION

SECTION **AT**

CONTENTS

<hr/>	
71B type & RE4R01A	
PREPARATION	AT- 2

<hr/>	
71B type	
PRECAUTIONS	AT- 6
ON-VEHICLE SERVICE	AT- 7
TROUBLE-SHOOTING AND DIAGNOSES	AT- 11
REMOVAL AND INSTALLATION	AT- 70
MAJOR OVERHAUL	AT- 73
DISASSEMBLY	AT- 79
REPAIR FOR COMPONENT PARTS	AT- 86
ASSEMBLY	AT-109

<hr/>	
RE4R01A	
PRECAUTIONS	AT-125
A/T CONTROL DIAGRAM	AT-126
ON-VEHICLE SERVICE	AT-129
TROUBLE-SHOOTING AND DIAGNOSES	AT-132
REMOVAL AND INSTALLATION	AT-193
MAJOR OVERHAUL	AT-194
DISASSEMBLY	AT-198
REPAIR FOR COMPONENT PARTS	AT-209
ASSEMBLY	AT-254



<hr/>	
71B type & RE4R01A	
SERVICE DATA AND SPECIFICATIONS (S.D.S.)	AT-272

When you read wiring diagrams:

- Read GI section, "HOW TO READ WIRING DIAGRAMS".
- See EL section, "POWER SUPPLY ROUTING" for power distribution circuit.

AT

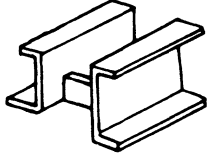
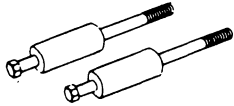
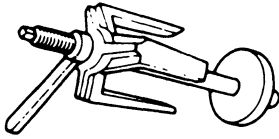
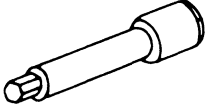
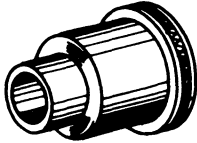
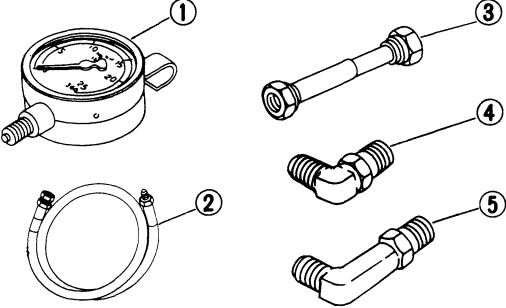
SPECIAL SERVICE TOOLS

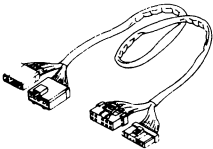
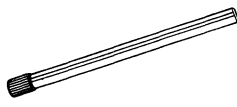
Tool number (Kent-Moore No.) Tool name	Description	
ST07870000 (J34308) (J3289-20) Transmission case stand		Disassemble and assemble
ST25850000 (J25721-A) Sliding hammer		Removing oil pump assembly
ST25420001 (J26063) Clutch spring compressor		Removing and installing clutch springs
ST25570001 (J23659-A) Hex head extension		Removing and installing one-way clutch inner race
ST25580001 (-) Oil pump assembling gauge		Installing oil pump
ST2505S001 (-) Oil pressure gauge set		Measuring oil pressure ① Oil pressure gauge ② Hose ③ Joint pipe ④ Adapter ⑤ Adapter
11025-61501 (-) Adapter		Adapter for oil pressure gauge
KV319K0010 (J34270) Diagnostic sub-harness		Checking lock-up control unit
(J33909) Transmission alignment arbor		Installing drum support on O.D. case

PREPARATION

71B type

SPECIAL SERVICE TOOLS (Cont'd)

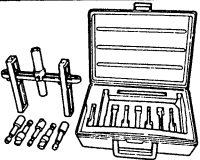
Tool number (Kent-Moore No.) Tool name	Description	
(J34291) Shim setting gauge set		Selecting front clutch thrust washer, oil pump cover bearing race, O.D. thrust washer and O.D. bearing race

COMMERCIAL SERVICE TOOL

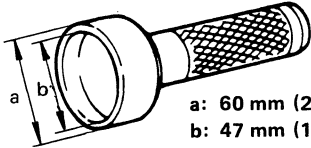
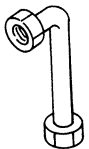
Tool name	Description	
Extension oil seal puller		Removing extension oil seal
Extension oil seal drift	 <p style="margin-left: 100px;">a: 60 mm (2.36 in) dia. b: 47 mm (1.85 in) dia.</p>	Installing extension oil seal
Joint pipe	 <p style="margin-left: 100px;">(Make this pipe by bending ST25053000)</p>	Measuring oil pressure

SPECIAL SERVICE TOOLS

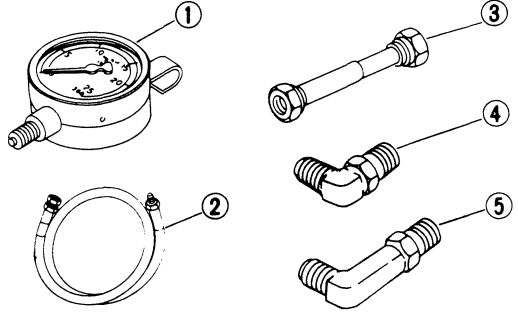
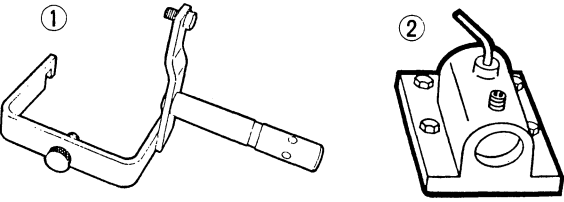
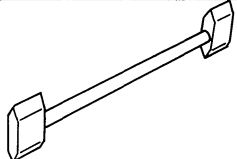
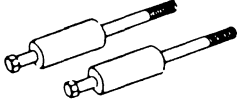
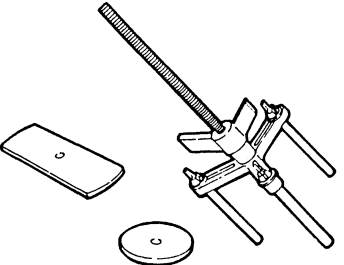
Tool number (Kent-Moore No.) Tool Name	Description
<p>ST2505S001 (J25695-A) Oil pressure gauge set</p> <p>① ST25051001 (J25695-1) Oil pressure gauge</p> <p>② ST25052000 (J25695-2) Hose</p> <p>③ ST25053000 (J25695-3) Joint pipe</p> <p>④ ST25054000 (J25695-4) Adapter</p> <p>⑤ ST25055000 (J25695-5) Adapter</p>	<p>Measuring line pressure</p> 
<p>ST07870000 Transmission case stand</p> <p>① (J37068) Transmission holding fixture</p> <p>② (J3289-20) Bench mount fixture</p>	<p>Disassembling and assembling A/T</p> 
<p>KV31102100 (J37065) Torque converter one-way clutch check tool</p>	<p>Checking one-way clutch in torque converter</p> 
<p>ST25850000 (J25721-A) Sliding hammer</p>	<p>Removing oil pump assembly</p> 
<p>KV31102400 (J34285) Clutch spring compressor (J34285-87) Adapter kit</p>	<p>Removing and installing clutch return springs</p> 

PREPARATION

RE4R01A

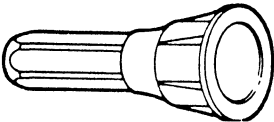
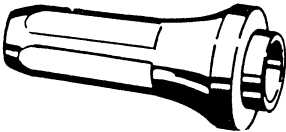
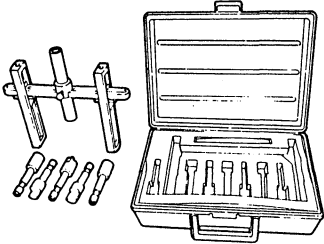
Tool number (Kent-Moore No.) Tool Name	Description
ST33200000 (J37066) Drift	 <p data-bbox="1140 310 1432 373">Installing oil pump housing oil seal</p>
ST33200000 (J37067) Drift	 <p data-bbox="1140 478 1367 510">Installing rear oil seal</p>
(J34291) Shim selecting tool (J34291-23) Plunger	 <p data-bbox="1140 646 1416 737">Selecting oil pump cover bearing race and oil pump thrust washer</p>

Service Notice

- Before proceeding with disassembly, thoroughly clean the outside of the transmission. It is important to prevent the internal parts of the transmission from becoming contaminated by dirt or other foreign matter.
- Disassembly should be done in a clean work area.
- Use a nylon cloth or paper towel for wiping parts clean. Common shop rags can leave lint that might interfere with the transmission operation.
- When disassembling parts, be sure to place them in order in parts rack so they can be put back in the unit in their proper positions.
- All parts should be carefully cleaned with a general purpose, non-flammable solvent before inspection or reassembly.
- Gaskets, seals, and O-rings should be replaced. It is also very important to perform functional tests whenever it is designated.
- The valve body contains many precision parts and requires extreme care when parts are

removed and serviced. Place removed parts on a parts rack so they can be put back in the valve body in the same positions and sequences. Care will also prevent springs and small parts from becoming scattered or lost.

- Before assembly, apply a coat of recommended A.T.F. to all parts. Vaseline may be applied to O-rings and seals. Do not use any grease.
- Care should be taken to avoid damaging O-rings, seals and gaskets when assembling.
- After overhaul, refill the transmission with new A.T.F.

Abbreviations used throughout this section stand for the following:

- A.T.F. Automatic Transmission Fluid
- D₁ Drive range 1st gear
- D₂ Drive range 2nd gear
- D₃ Drive range 3rd gear
- D₄ Drive range 4th gear
- O.D. Overdrive
- 1₂ 1 range 2nd gear
- 1₁ 1 range 1st gear

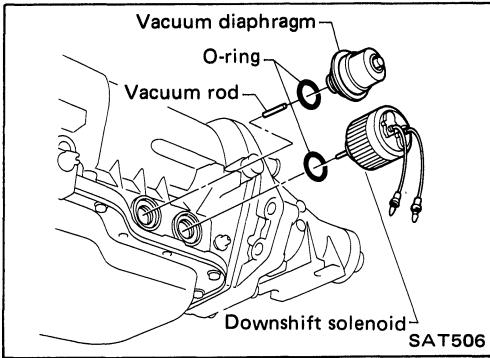

Control valve

1. Drain fluid by removing oil pan.
2. Remove kickdown solenoid and vacuum diaphragm & rod.
Be careful not to lose vacuum rod.

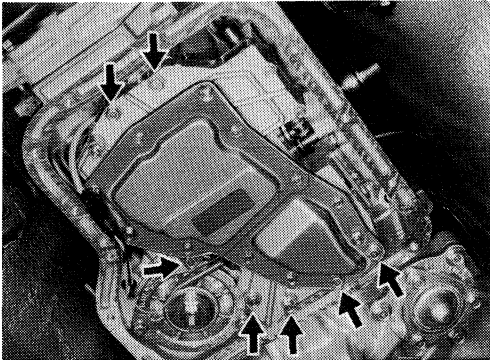

3. Remove control valve assembly.
Be careful not to drop manual valve out of valve body.
4. Disassemble, inspect and assemble control valve assembly.
Refer to Control Valve Body.

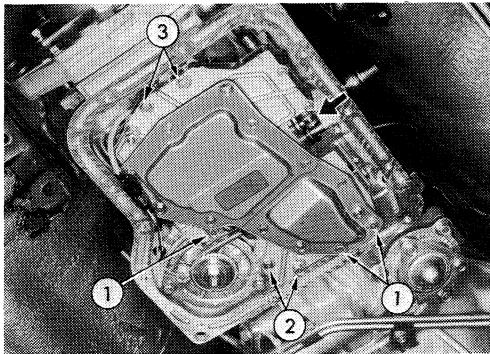

5. Install control valve assembly.
 - Set manual shaft at Neutral, then align manual plate with groove in manual valve of control valve assembly.
 - Securing bolts come in 3 different lengths.
 - After installing control valve to transmission case, make sure that control lever can be moved to all positions.
6. Install kickdown solenoid and vacuum diaphragm & rod.
Make sure that vacuum diaphragm rod does not interfere with side plate of control valve.

Bolt length:
 1 40 mm (1.57 in)
 2 35 mm (1.38 in)
 3 25 mm (0.98 in)

Extension Oil Seal Replacement

1. Remove oil seal.

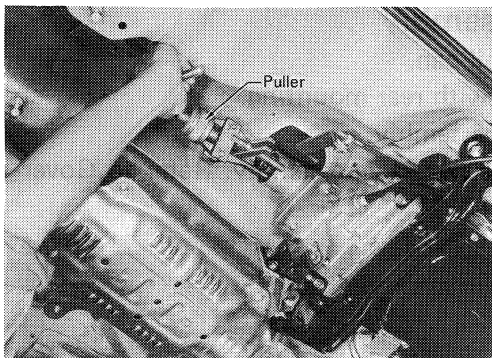

Extension Oil Seal Replacement (Cont'd)

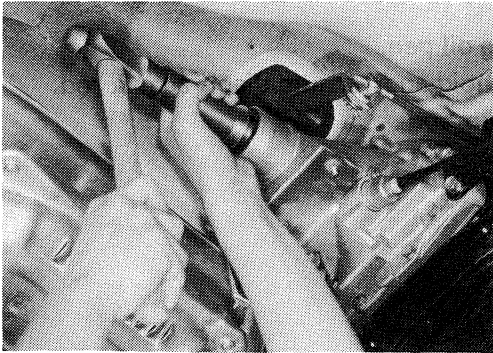

2. Apply coat of A.T.F. to oil seal surface, then drive new seal into place.
3. Coat sealing lips with vaseline, then install propeller shaft.

Parking Component

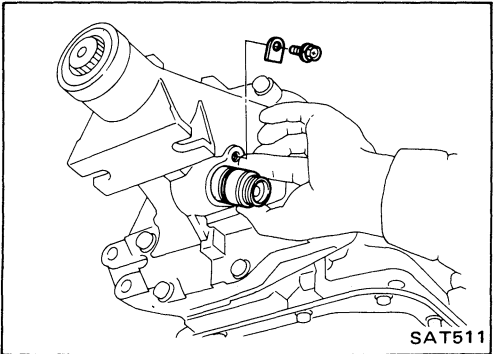

1. Remove oil pan.
2. Remove propeller shaft.
3. Remove speedometer pinion.

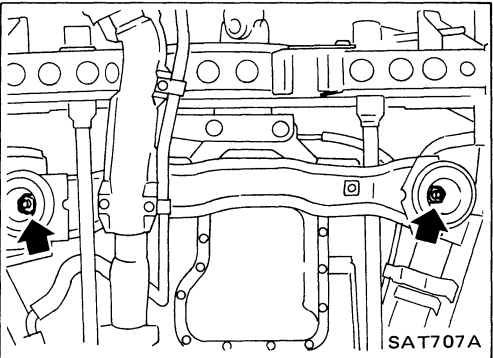

4. Support transmission with a jack, then remove rear mounting bolts.

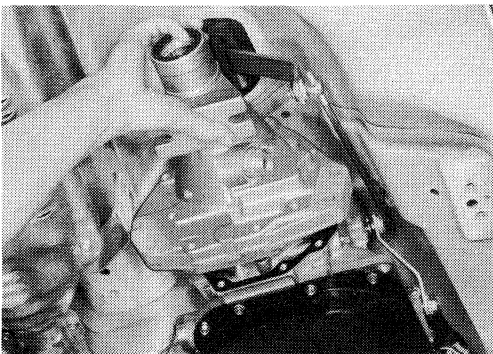

5. Remove rear extension bolts, then draw out rear extension with rear mounting.
6. Remove control valve assembly.
7. Inspect and repair parking components. Check component parts for wear or damage.

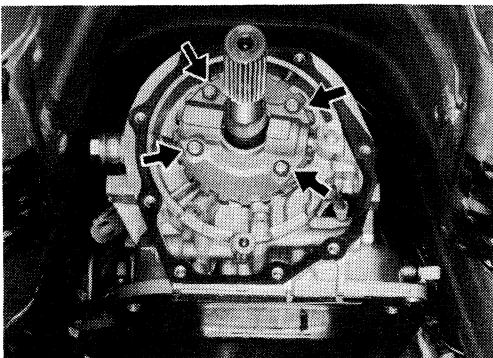

Governor Valve Assembly

1. Drain oil by removing oil pan.
2. Remove rear extension with rear mounting.
3. Remove governor valve assembly.
4. Inspect and repair governor valve assembly. Refer to Governor for inspection.

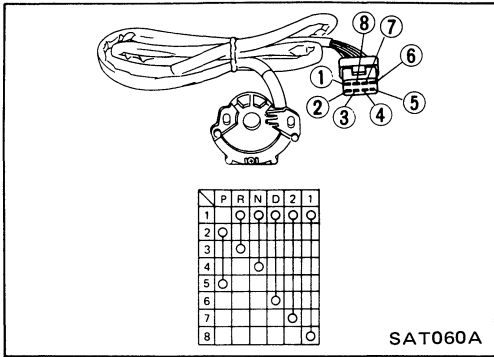

Inhibitor Switch Adjustment

Disconnect harness at connector, then remove inhibitor switch.

- Check continuity at each range.
- With selector lever held in "Neutral", turn manual lever an equal amount in both directions to see if current flow ranges are nearly the same. (Current normally begins to flow before manual lever reaches a angle of 1.5° in either direction.)
If current flows outside normal range, or if normal flow range is out of specifications, properly adjust inhibitor switch.

Adjust inhibitor switch as follows:

1. Place the manual valve in Neutral (vertical position).
2. Remove the screw.

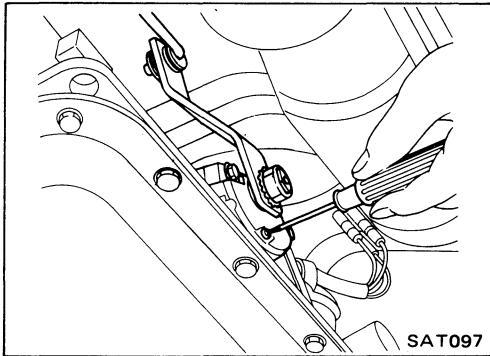

3. Loosen the attaching bolts.
4. With an aligning pin [2.0 mm (0.079 in) dia.], move the switch until the pin falls into the hole in the rotor.
5. Tighten the attaching bolts equally.
6. Recheck for continuity. If necessary, replace the switch.

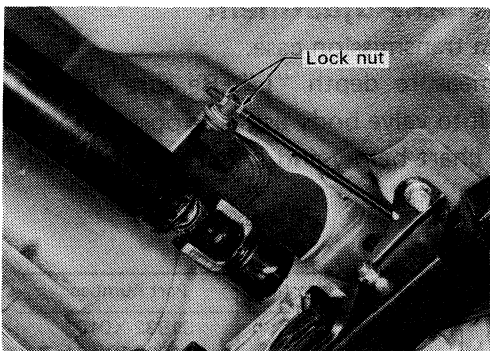
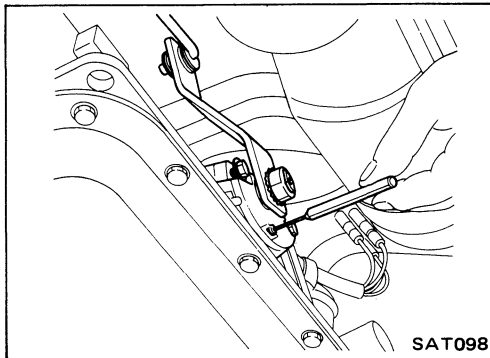

Manual Linkage Adjustment (Floor shift models)

Move the selector lever from the "P" range to "1" range. You should be able to feel the detents in each range.

If the detents cannot be felt or the pointer indicating the range is improperly aligned, the linkage needs adjustment.

1. Place selector lever in "P" range.
2. Loosen lock nuts.
3. Tighten lock nut (X) until it touches trunnion, pulling selector lever toward "R" range side without pushing button.
4. Back off lock nut (X) 1 turn and tighten lock nut (Y) to the specified torque.

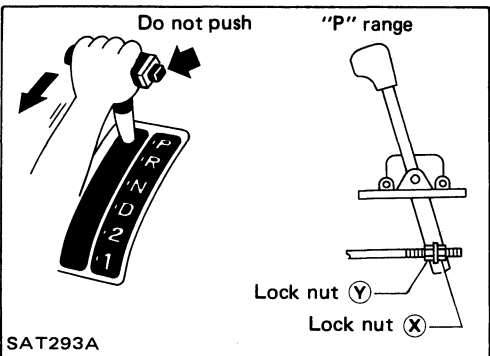

☒ : Lock nut

11 - 15 N·m (1.1 - 1.5 kg·m, 8 - 11 ft·lb)

5. Move selector lever from "P" range to "1" range. Make sure that selector lever can move smoothly.

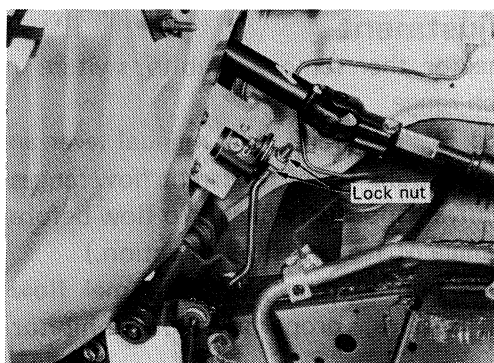

Manual Linkage Adjustment (Column shift models)

Move the selector lever from the "P" range to "1" range. You should be able to feel the detents in each range.

If the detents cannot be felt or the pointer indicating the range is improperly aligned, the linkage needs adjustment.

1. Place selector lever in "P" range.
2. Loosen locknuts.
3. Tighten lock nut (A) until it touches trunnion, pulling selector lever toward "R" range side without pushing button.
4. Back off lock nut (A) two turns and tighten lock nut (B) to the specified torque.

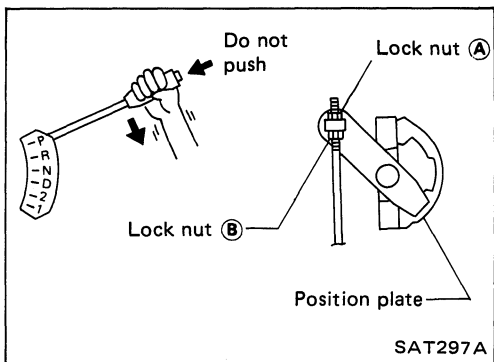

Lock nut
11 - 15 N·m
(1.1 - 1.5 kg·m, 8 - 11 ft·lb)

5. Move selector lever from "P" range to "1" range. Make sure that selector lever can move smoothly.

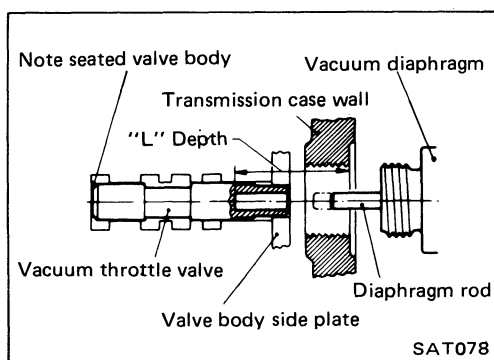

Vacuum Diaphragm Rod Adjustment

1. Remove diaphragm from transmission case.
2. With a depth gauge, measure depth "L". Be sure vacuum throttle valve is pushed into valve body as far as possible.
3. Check "L" depth with chart below and select proper length rod.

Vacuum diaphragm rod selection

Measured depth "L" mm (in)	Rod length mm (in)	Part number
Under 25.55 (1.0059)	29.0 (1.142)	31932-X0103
25.65 - 26.05 (1.0098 - 1.0256)	29.5 (1.161)	31932-X0104
26.15 - 26.55 (1.0295 - 1.0453)	30.0 (1.181)	31932-X0100
26.65 - 27.05 (1.0492 - 1.0650)	30.5 (1.201)	31932-X0102
Over 27.15 (1.0689)	31.0 (1.220)	31932-X0101

Downshift Solenoid, O.D. Cancel Solenoid and Lock-up Solenoid

Refer to TROUBLE-SHOOTING AND DIAGNOSES.

Kickdown Switch Adjustment

Refer to TROUBLE-SHOOTING AND DIAGNOSES.

Preliminary Checks

FLUID LEAKAGE

To detect a fluid leak:

- 1) Raise vehicle.
- 2) Clean area suspected of leaking.
- 3) Start engine, apply foot brake, place shift control lever in drive, and wait a few minutes.
- 4) Stop engine.
- 5) Check for fresh leakage.

FLUID CONDITION

- 1) Dark or Black Fluid:
 - With a burned odor
 - Worn friction material.

- 2) Milky Pink Fluid: Water Contamination
 - Road water entering through filler tube or breather.

- 3) Varnished Fluid, light to dark brown and tacky: Oxidation
 - Over or Underfilling.
 - Overheating.

If these conditions exist, check operation of A/T as specified in Road Testing. Especially if the condition as described in 2) exists, it will be necessary to wash all parts in A/T or replace A/T assembly with new one.

Road Testing

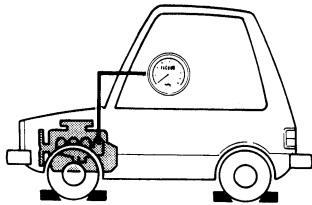

SAT596

- Before starting road tests, install vacuum gauge.
- Perform road tests, using "Symptom" chart. Refer to page AT-18.

"P" RANGE

1. Place shift control lever in "P" range and start the engine. Stop the engine and repeat the procedure in all other ranges, including neutral.
2. Stop vehicle on a slight upgrade and place selector lever in "P" range. Release parking brake to make sure vehicle remains locked.

"R" RANGE

1. Manually move selector lever from "P" to "R", and note shift quality.
2. Drive the vehicle in reverse long enough to detect slippage or other abnormalities.

"N" RANGE

1. Manually move selector lever from "R" and "D" to "N" and note quality.
2. Release parking brake with selector lever in "N" range. Lightly depress accelerator pedal to make sure vehicle does not move. (When vehicle is new or soon after clutches have been replaced, vehicle may move slightly. This is not a problem.)

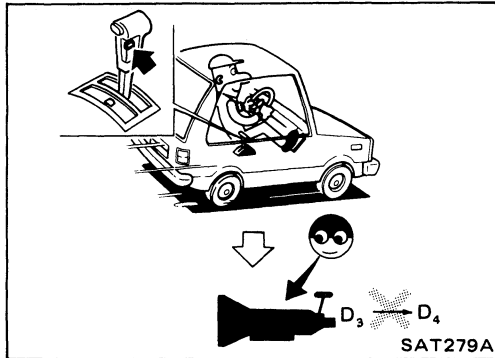
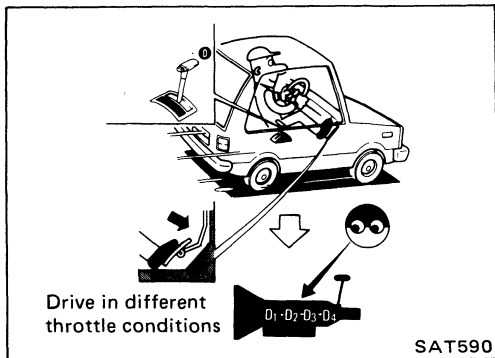

Road Testing (Cont'd)

"D" RANGE

1. Manually shift the gear selector from "N" to "D" range, and note shift quality.
2. Using the shift schedule as a reference, drive vehicle in "D" range. Record, on symptom chart, respective vehicle speeds at which upshifting and downshifting occur. Check that there is not a considerable jolt when shifting gears. Also determine the timing at which shocks are encountered during shifting and which clutches are engaged.
3. Check to determine if shifting to overdrive gear cannot be made while O.D. control switch is "OFF" or power shift switch is "POWER".

4. When vehicle is being driven in the 65 to 85 km/h (40 to 53 MPH) in "D₃" range at half to light throttle position, fully depress accelerator pedal to make sure it downshifts from 3rd to 2nd gear.
5. When vehicle is being driven in the 25 to 35 km/h (16 to 22 MPH) ("D₂" range) at half to light throttle position, fully depress accelerator pedal to make sure it downshifts from 2nd to 1st gear.

"2" RANGE

1. While vehicle is being driven in "2" range, make sure that it does not shift into 1st or 3rd gear, despite speed changes.
2. Move selector lever to "D" range and allow vehicle to operate at 40 to 50 km/h (25 to 31 MPH). Then, shift to "2" range to make sure it downshifts to 2nd gear.

"1" RANGE

1. Move selector lever in to "1" range and allow vehicle to run. Ensure that it does not upshift from 1st to 2nd gear although vehicle speed increases.
2. While vehicle is being driven in "1" range, release accelerator pedal to make sure that engine compression acts as a brake.
3. Place selector lever in to "D" or "2" range and allow vehicle to run at 20 to 30 km/h (12 to 19 MPH). Then, move selector lever to "1" range to make sure the downshift to 1st gear is made.

Road Testing (Cont'd)

**VEHICLE SPEED AND LINE PRESSURE
WHEN SHIFTING GEARS**

1. Disconnect harness from lockup control unit.
Carry out road test to determine if all items listed in the following chart are within their specified values.
2. Reconnect harness to lockup control unit.
Carry out road test to see if shifting corresponds to the specified shift schedule pattern.

Z24i engine models

Throttle position	Gearshift	Vehicle speed km/h (MPH)
Full throttle	D ₁ → D ₂	53 - 56 (33 - 35)
	D ₂ → D ₃	97 - 105 (60 - 65)
	D ₃ → D ₄	—
	D ₄ → D ₃	—
	D ₃ → D ₂	77 - 85 (48 - 53)
	D ₂ → D ₁	40 - 47 (25 - 29)

**VG30i engine models
(Final gear ratio: 3.900)**

Throttle position	Gearshift	Vehicle speed km/h (MPH)
Full throttle	D ₁ → D ₂	56 - 64 (35 - 40)
	D ₂ → D ₃	103 - 111 (64 - 69)
	D ₃ → D ₄	—
	D ₄ → D ₃	—
	D ₃ → D ₂	94 - 102 (58 - 63)
	D ₂ → D ₁	44 - 51 (27 - 32)

**VG30i engine models
(Final gear ratio: 4.375)**

Throttle position	Gearshift	Vehicle speed km/h (MPH)
Full throttle	D ₁ → D ₂	50 - 57 (31 - 35)
	D ₂ → D ₃	93 - 100 (58 - 62)
	D ₃ → D ₄	—
	D ₄ → D ₃	—
	D ₃ → D ₂	84 - 91 (52 - 57)
	D ₂ → D ₁	39 - 46 (24 - 29)

SHIFT SCHEDULE

Z24i engine models

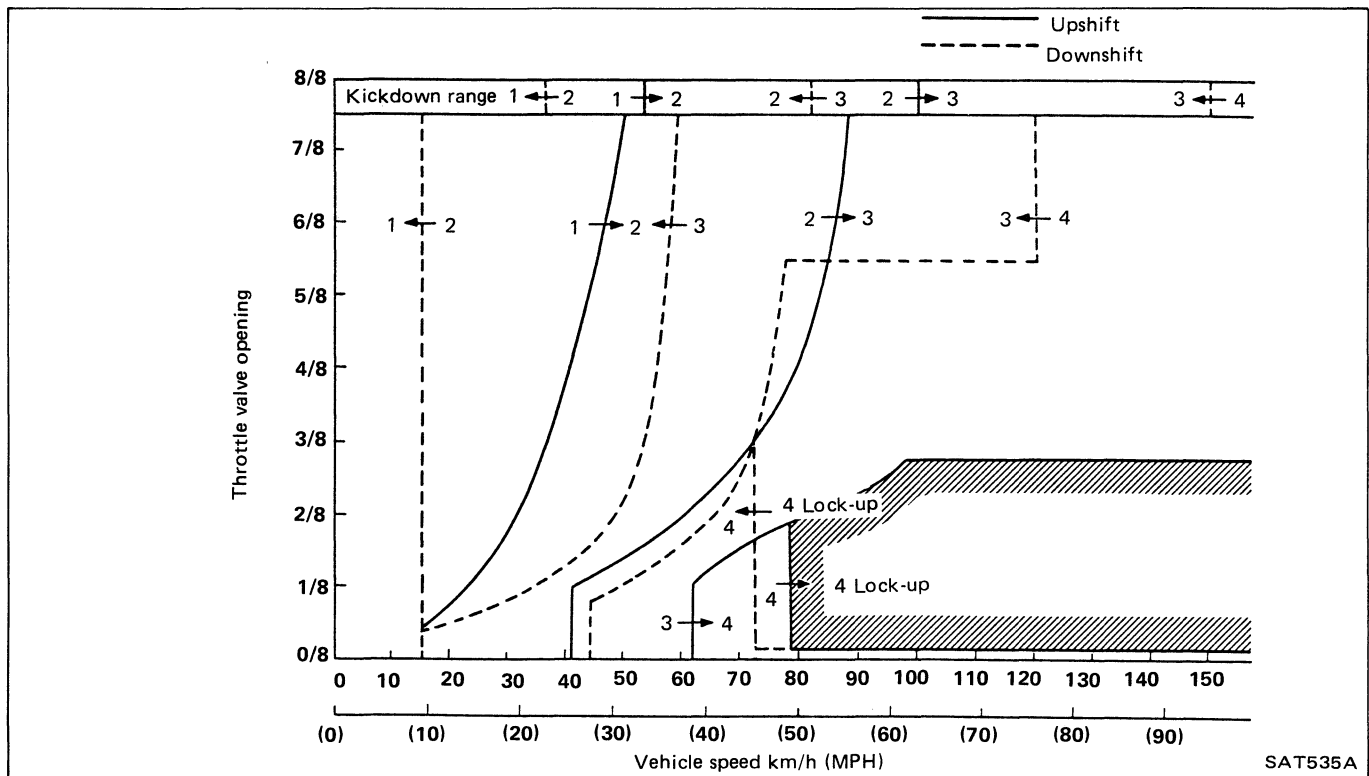

Road Testing (Cont'd)

VG30i engine models (Final gear ratio: 3.900)

[Standard pattern]

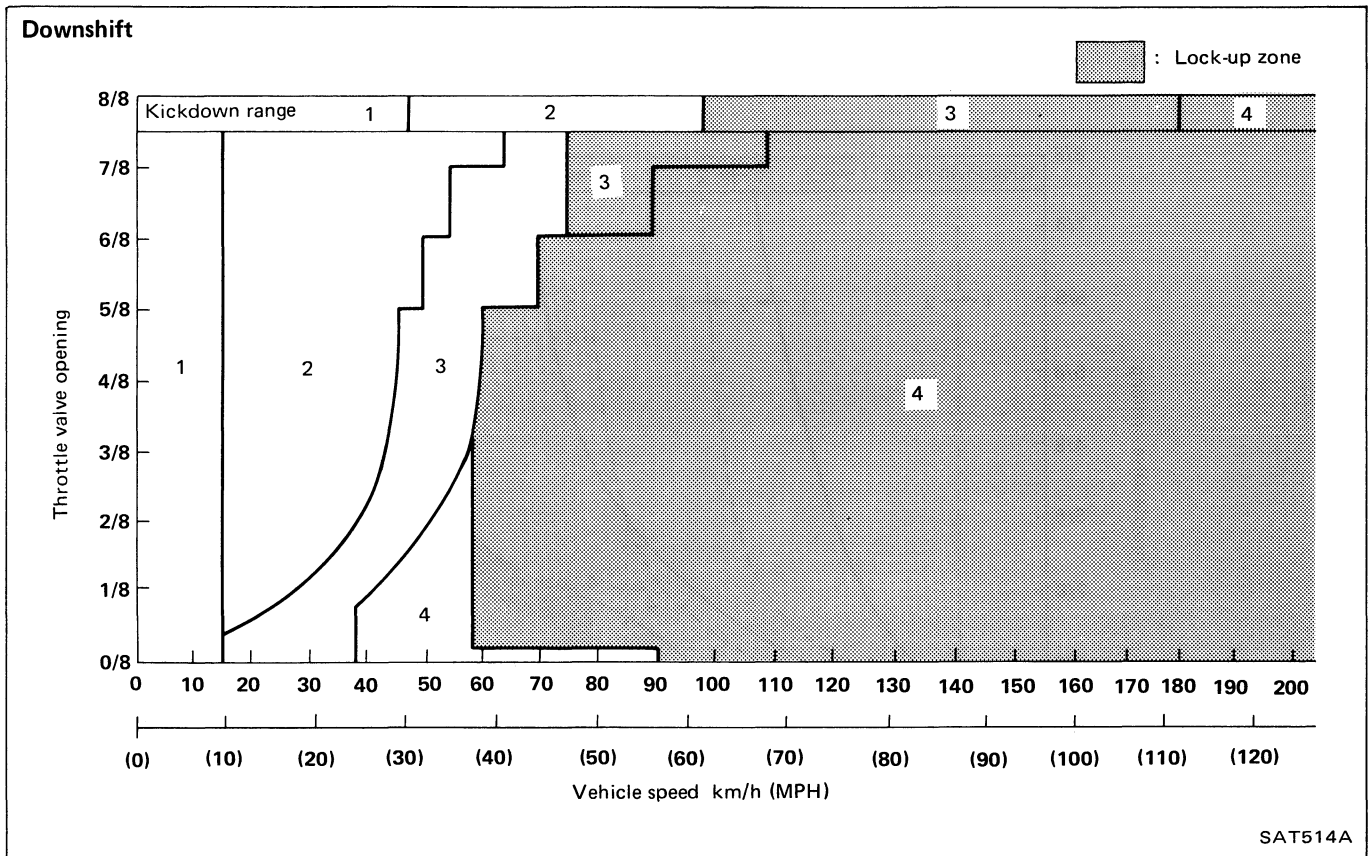
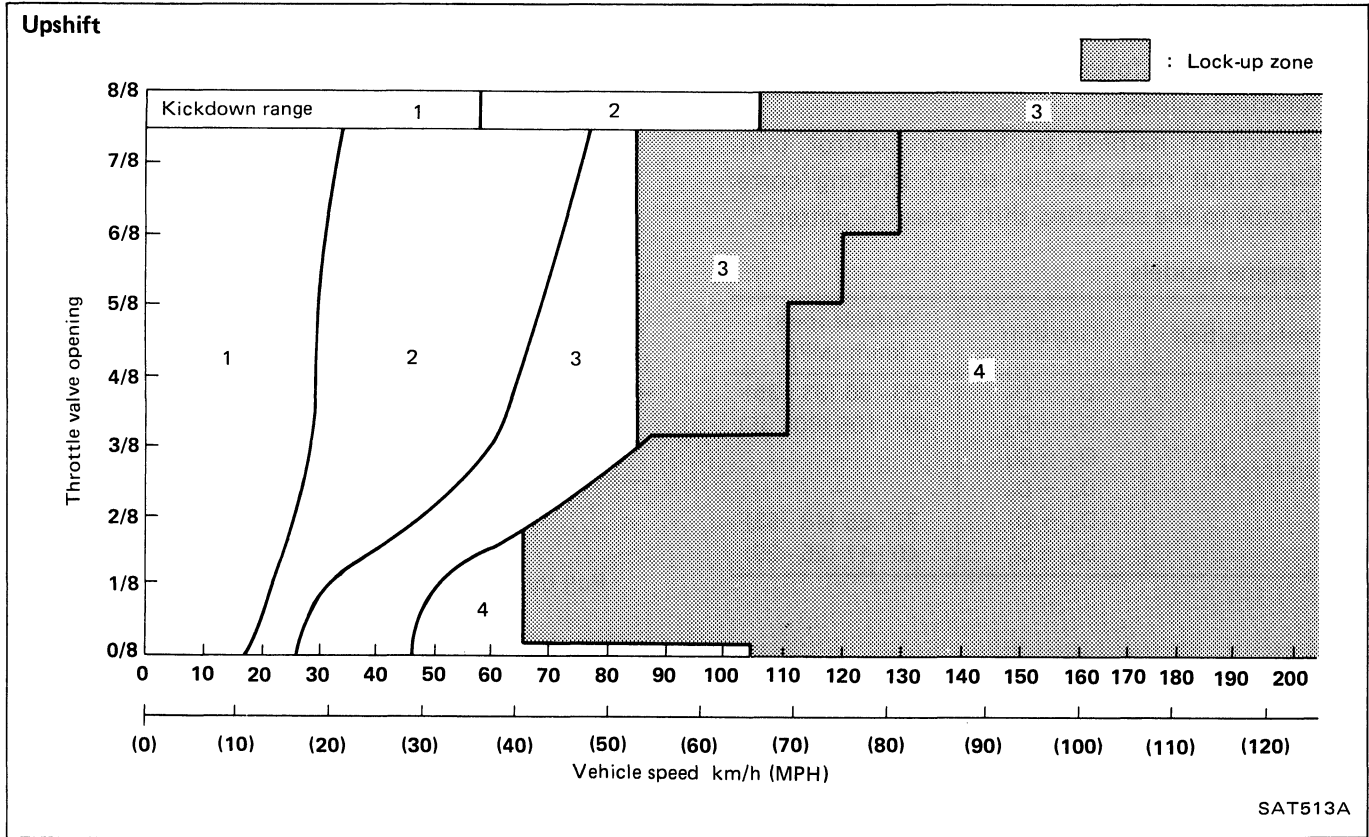

Road Testing (Cont'd)

VG30i engine models (Final gear ratio: 3.900)

[Power pattern]

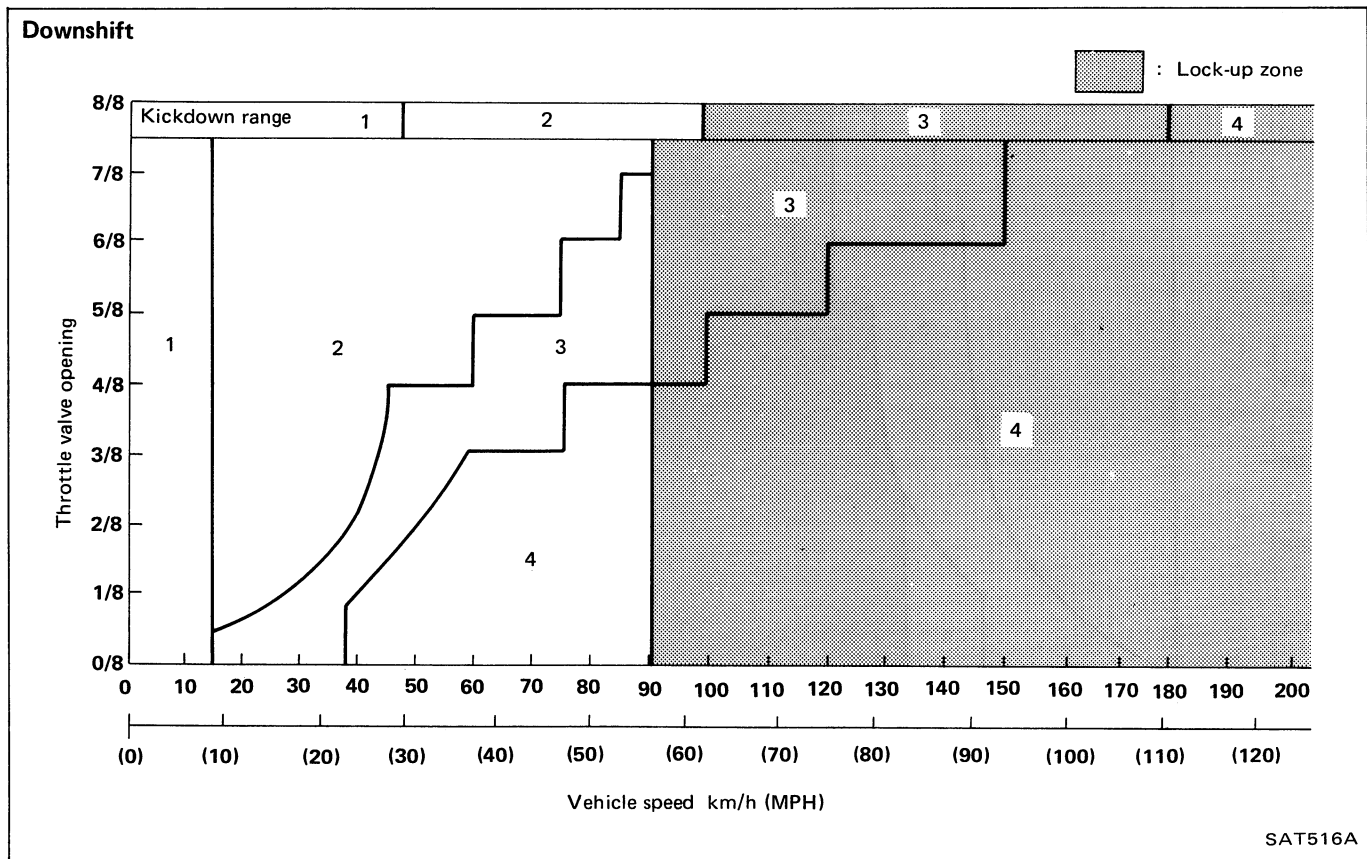
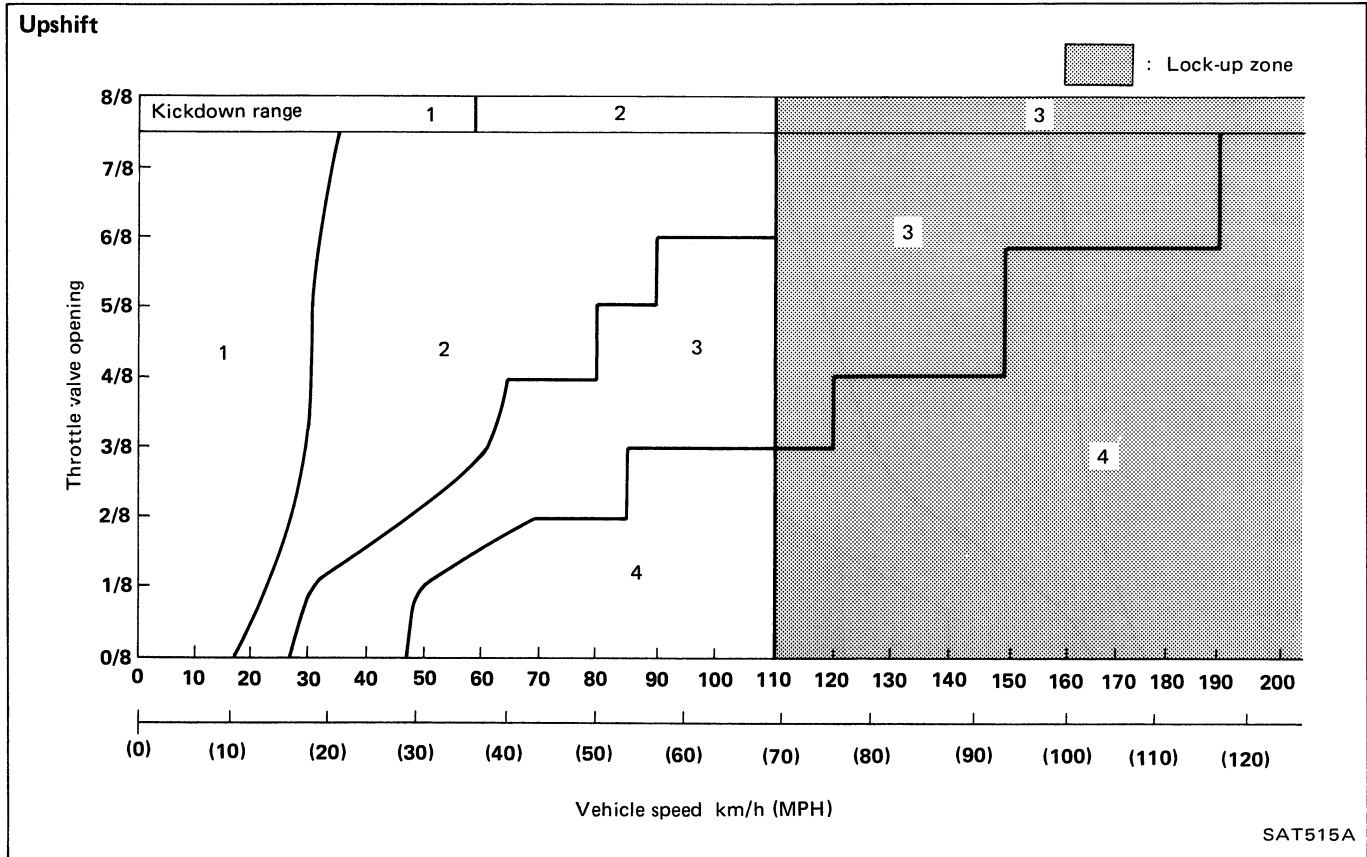

Road Testing (Cont'd)

VG30i engine models (Final gear ratio: 4.375)

[Standard pattern]

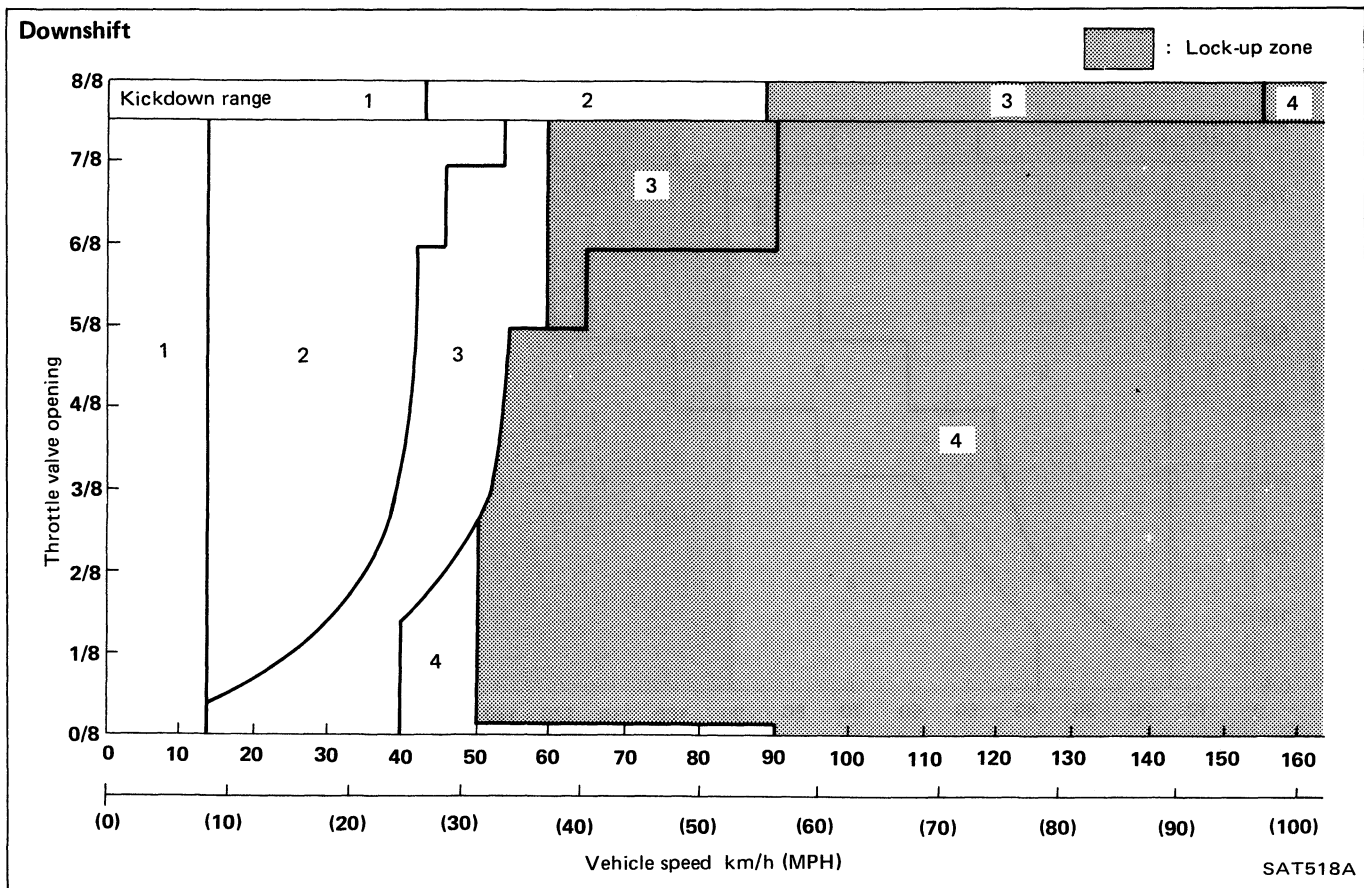
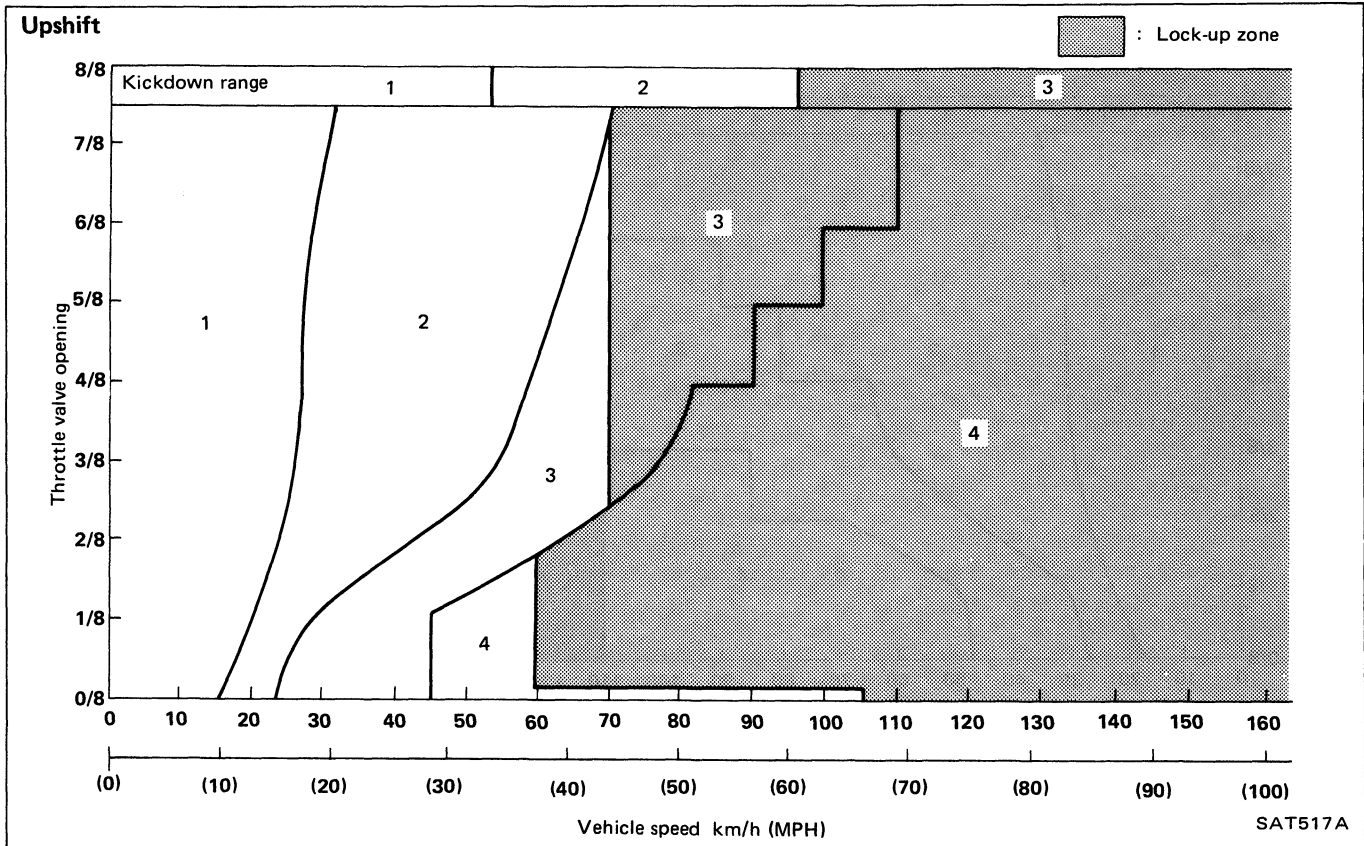

Road Testing (Cont'd)

VG30i engine models (Final gear ratio: 4.375)

[Power pattern]

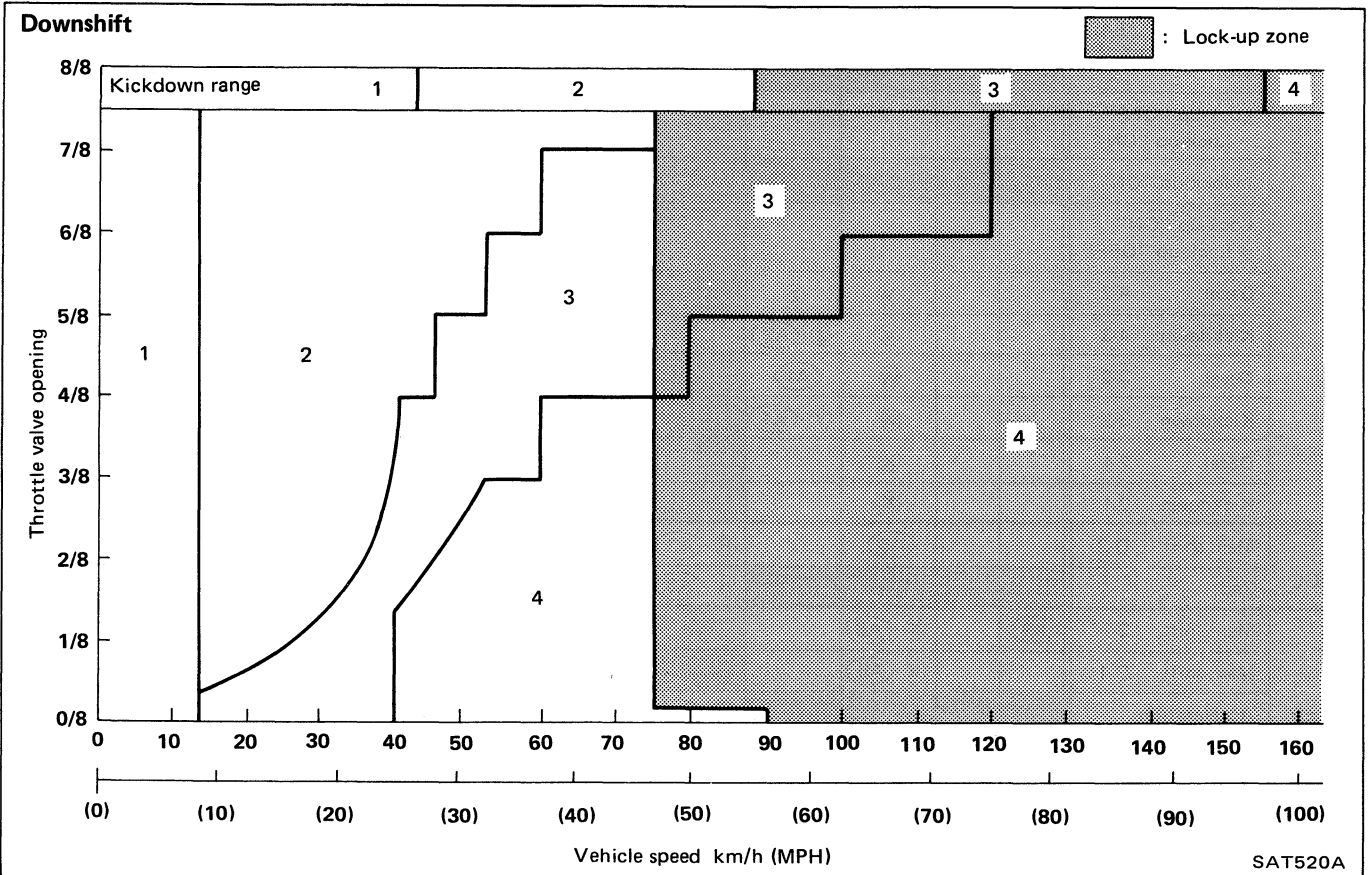
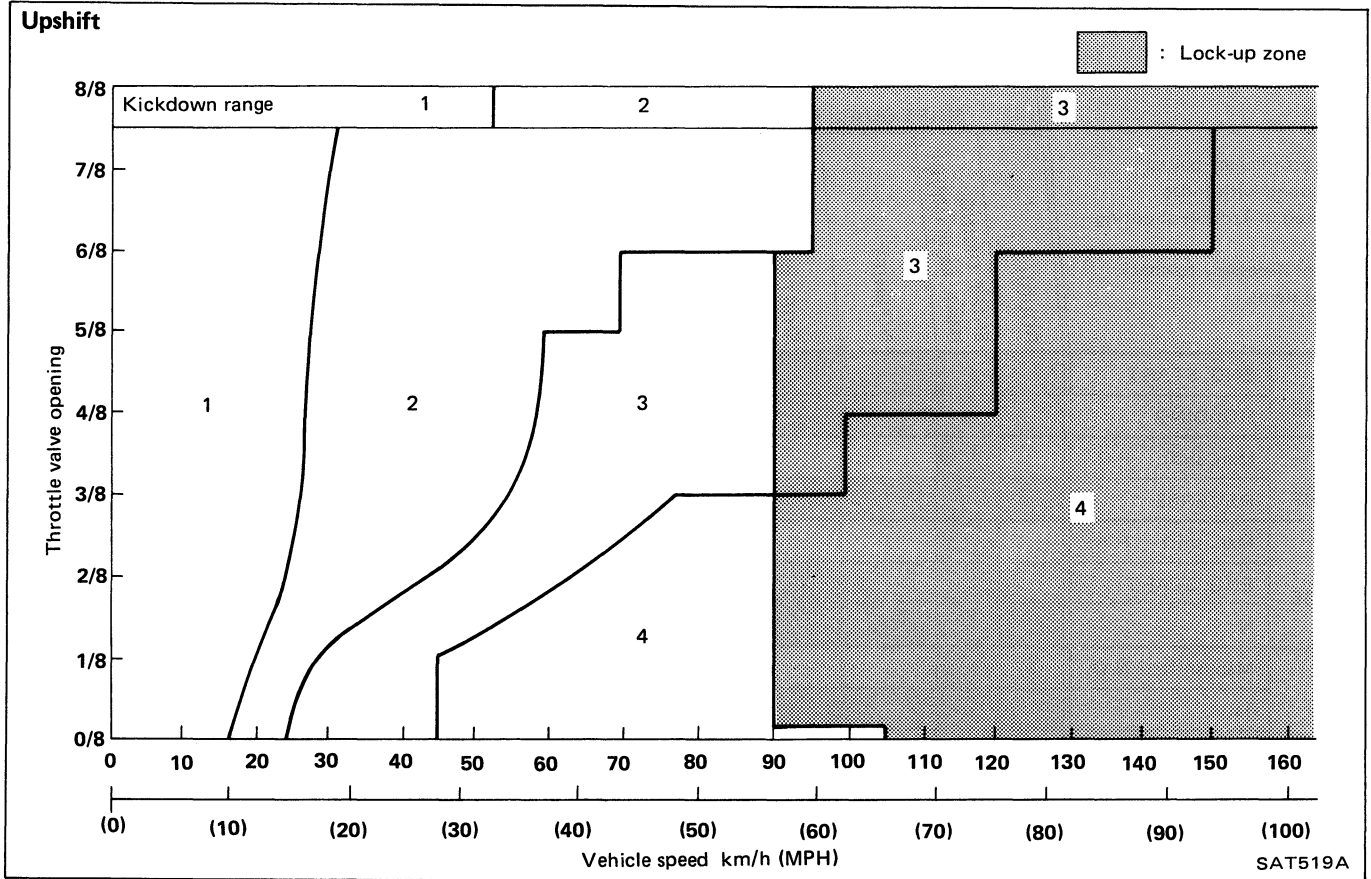

Road Test Symptom Chart

Numbers in chart below correspond with those indicated in Trouble-shooting chart.
It is not necessary to check shaded items.

		SHIFT QUALITY				VEHICLE WON'T MOVE	CRUISE SLIPPAGE	POOR POWER/ACCELERATION	NOISY	ENGINE WON'T START	VEHICLE WON'T STAND STILL	NO ENGINE BRAKING	NO LOCK-UP	COMMENTS	
		ROUGH	SHIFT TIMING [Mark km/h (MPH)]	NO SHIFT	SHIFT SLIPPAGE										
PARK RANGE	ENG. START									(A)					
	HOLDING								(B)		(C)				
"R" RANGE	Man. shift P-R					(A3)			(A4)						
	REVERSE					(E)·(A3)	(E)	(E)	(A4)						
"N" RANGE	Man. shift R-N								(A4)						
	ENG. START									(A)					
	N								(B)		(D)				
"D" RANGE	Man. shift N-D	(F)				(G)·(A3)			(A4)						
	1st					(G)·(A3)		(I)	(A4)						
	Auto shift 1-2	(O)		(J)	(R)				(A4)						
	2nd							(U)	(A4)						
	Auto shift 2-3	(P)		(K)	(S)				(A4)						
	3rd							(U)	(A4)						
	Auto shift 3-4	(Q)		(L)	(T)				(A4)						
	4th							(U)	(A4)						
	Lock-up "OFF" → Lock-up "ON"	(N)							(A4)				(M)		
	In lock-up "ON"								(A4)				(M)		
	Lock-up "ON" → Lock-up "OFF"								(A4)						
	Decel. 4-3			(V)	(Z)				(A4)						
	Kickdown 4-3			(V)	(Z)·(A2)				(A4)						
	Decel. 3-2			(W)	(A1)				(A4)						
	Kickdown 3-2			(W)	(Y)·(A1)				(A4)						
	Decel. 2-1			(X)					(A4)						
	Kickdown 2-1			(X)					(A4)						
	"2" RANGE	Man. shift D-2			(A5)		(H)·(A3)			(A4)					
		2nd					(H)·(A3)		(I)	(A4)					
	"1" RANGE	Man. shift 2-1	(A9)		(X)·(A8)					(A4)					
Man. shift D-1				(X)·(A6)					(A4)						
Acceleration						(H)·(A3)		(I)	(A4)						
"1" Engine Braking									(A4)			(A7)			

Trouble-shooting Chart

Numbers are arranged in order of probability. Perform inspections starting with number one and working up. Circled numbers indicate that the transmission must be removed from the vehicle.

Reference		ON vehicle													OFF vehicle																					
		Oil level	Range select linkage	Inhibitor switch and wiring	Vacuum diaphragm and piping	Kickdown solenoid, switch and wiring	Engine idling rpm	Line pressure	Control valve	Governor	2nd band servo	Transmission air check	Oil quality	Ignition switch and starter motor	Engine adjustment, brake inspection	O.D. band servo	O.D. control SW.	O.D. cancel solenoid	Lock-up solenoid	Lock-up control unit and sensors	Direct clutch	Forward clutch (Rear)	High-reverse clutch (Front)	O.D. band brake	2nd band brake	Low and reverse brake	Oil pump	Oil passage leak	Torque converter	Transmission one-way clutch	Park linkage	Planetary gear	O.D. cancel valve	Lock-up control valve	Accumulator	
A	Engine does not start in "N", "P" ranges.	. 2 3	1	5
	Engine starts in range other than "N" and "P".	. 1 2
B	Transmission noise in "P" and "N" ranges.	1	3
C	Vehicle moves when changing into "P" range or parking gear does not disengage when shifted out of "P" range.	. 1	2	
D	Vehicle runs in "N" range.	. 1
E	Vehicle will not run in "R" range (but runs in "D", "2" and "1" ranges). Clutch slips. Very poor acceleration.	1 2
	Vehicle braked when shifting into "R" range.
F	Sharp shock in shifting from "N" to "D" range.	2 . 1	3 4
G	Vehicle will not run in "D" range (but runs in "2", "1" and "R" ranges).	. 1
H	Vehicle will not run in "D", "1", "2" ranges (but runs in "R" range). Clutch slips. Very poor acceleration.	1 2
	Clutches or brakes slip somewhat in starting.	1 2
I	Excessive creep.
	No creep at all.	1 2
	Failure to change gear from "1st" to "2nd".	. 1 .	2 3
K	Failure to change gear from "2nd" to "3rd".	. 1 .	2 3
L	Failure to change gear from "3rd" to "4th".	. 1 .	2 3
	Too high a gear change point from "1st" to "2nd", from "2nd" to "3rd", from "3rd" to "4th".	1 2 .	3 5 6
	Gear change directly from "1st" to "3rd" occurs.
	Gear change directly from "2nd" to "4th" occurs.
M	Lock-up does not occur in any range.
N	Large jolt changing from lock-up "OFF" to "ON".

Trouble-shooting Chart (Cont'd)

Numbers are arranged in order of probability. Perform inspections starting with number one and working up. Circled numbers indicate that the transmission must be removed from the vehicle.

Reference		ON vehicle										OFF vehicle																											
		Oil level	Range select linkage	Inhibitor switch and wiring	Vacuum diaphragm and piping	Kickdown solenoid, switch and wiring	Engine idling rpm	Line pressure	Control valve	Governor	2nd band servo	Transmission air check	Oil quality	Ignition switch and starter motor	Engine adjustment, brake inspection	O.D. band servo	O.D. control SW.	O.D. cancel solenoid	Lock-up solenoid	Lock-up control unit and sensors	Direct clutch	Forward clutch (Rear)	High-reverse clutch (Front)	O.D. band brake	2nd band brake	Low and reverse brake	Oil pump	Oil passage leak	Torque converter	Transmission one-way clutch	Park linkage	Planetary gear	O.D. cancel valve	Lock-up control valve	Accumulator				
ⓐ	Too sharp a shock in change from "1st" to "2nd".	. . .	1	2	. . .	4	5	3	6	7	8	. . .	9	. . .	10	. . .	11	. . .	12	. . .	13	. . .	14	. . .	15	. . .	16	. . .	17	. . .	18	. . .	19	. . .	20
ⓑ	Too sharp a shock in change from "2nd" to "3rd".	. . .	1	. . .	2	3	. . .	5	4	6	7	. . .	8	. . .	9	. . .	10	. . .	11	. . .	12	. . .	13	. . .	14	. . .	15	. . .	16	. . .	17	. . .	18	. . .	19	. . .	20
ⓒ	Too sharp a shock in change from "3rd" to "4th".	. . .	1	. . .	2	3	. . .	7	. . .	4	. . .	5	6	. . .	8	. . .	9	. . .	10	. . .	11	. . .	12	. . .	13	. . .	14	. . .	15	. . .	16	. . .	17	. . .	18	. . .	19	. . .	20
ⓓ	Almost no shock or clutches slipping in change from "1st" to "2nd".	1	2	. . .	3	. . .	4	6	. . .	8	7	5	9	. . .	10	. . .	11	. . .	12	. . .	13	. . .	14	. . .	15	. . .	16	. . .	17
ⓔ	Almost no shock or slipping in change from "2nd" to "3rd". Engine races extremely fast.	1	2	. . .	3	. . .	4	6	. . .	8	7	5	9	. . .	10	. . .	11	. . .	12	. . .	13	. . .	14	. . .	15	. . .	16	. . .	17	
ⓕ	Almost no shock or slipping in change from "3rd" to "4th".	1	2	. . .	3	. . .	4	6	. . .	8	7	5	9	. . .	10	. . .	11	. . .	12	. . .	13	. . .	14	. . .	15	. . .	16	. . .	17	
	Vehicle braked by gear change from "1st" to "2nd".	2	. . .	1	4	. . .	3	5	
	Vehicle braked by gear change from "2nd" to "3rd".	3	. . .	2	. . .	1	4
	Vehicle braked by gear change from "3rd" to "4th".	2	. . .	1	3	4
ⓖ	Maximum speed not attained. Acceleration poor.	1	2	. . .	5	. . .	4	7	. . .	6	3	. . .	8	11	12	. . .	9	10	13	14
ⓗ	Failure to change gear from "4th" to "3rd".	. . .	1	3	4	. . .	5	2	6	7	8	9	10	11	. . .	12	. . .	13	. . .	14	. . .	15	. . .	16	. . .	17	. . .	18	. . .
ⓘ	Failure to change gear from "3rd" to "2nd" and from "4th" to "2nd".	. . .	1	3	4	. . .	6	5	2	7	10	8	. . .	9
ⓙ	Failure to change gear from "2nd" to "1st" or from "3rd" to "1st".	. . .	1	3	4	. . .	6	5	2	7	10	8	. . .	9	8
	Gear change shock felt during deceleration by releasing accelerator pedal.	. . .	1	. . .	2	3	. . .	4	5	6	7	8	. . .
	Too high a change point from "4th" to "3rd", from "3rd" to "2nd", from "2nd" to "1st".	. . .	1	. . .	2	3	. . .	4	5	6	7	8
ⓚ	Kickdown does not operate when depressing pedal in "3rd" within kickdown vehicle speed.	2	1	4	5	3	6	. . .	7
	Kickdown operates or engine overruns when depressing pedal in "3rd" beyond kickdown vehicle speed limit.	. . .	1	. . .	2	. . .	3	5	6	. . .	7	4	8	9
ⓛ	Races extremely fast or slips in changing from "4th" to "3rd" when depressing pedal.	1	2	4	. . .	6	5	3	7	8	9	. . .	10
Ⓜ	Races extremely fast or slips in changing from "3rd" to "2nd" when depressing pedal.	1	2	4	. . .	6	5	3	7	8	9	. . .	10
Ⓨ	Kickdown does not operate when depressing pedal in "4th" within kickdown vehicle speed.	2	1	4	5	3	7	6	8	. . .	9
	Kickdown operates or engine overruns when depressing pedal in "4th" beyond kickdown vehicle speed limit.	. . .	1	. . .	2	. . .	3	5	6	. . .	7	4	8	. . .	9
	Shift pattern does not change.	1	3	7	5	. . .	2	4	. . .	6	8	. . .	

Trouble-shooting Chart (Cont'd)

Numbers are arranged in order of probability. Perform inspections starting with number one and working up. Circled numbers indicate that the transmission must be removed from the vehicle.

Reference	ON vehicle														OFF vehicle																					
	Oil level	Range select linkage	Inhibitor switch and wiring	Vacuum diaphragm and piping	Kickdown solenoid, switch and wiring	Engine idling rpm	Line pressure	Control valve Governor	2nd band servo	Transmission air check	Oil quality	Ignition switch and starter motor	Engine adjustment, brake inspection	O.D. band servo	O.D. control SW.	O.D. cancel solenoid	Lock-up solenoid	Lock-up control unit and sensors	Direct clutch	Forward clutch (Rear)	High-reverse clutch (Front)	O.D. band brake	2nd band brake	Low and reverse brake	Oil pump	Oil passage leak	Torque converter	Transmission one-way clutch	Park linkage	Planetary gear	O.D. cancel valve	Lock-up control valve	Accumulator	Rear lubrication		
A3	1	2	3	5	.	.	6	4	8	7	9	10	.	.	11	.	.	12	.	.	.	
A4	1	2	3	.	6	4	.	5	
A5	.	1	2	4	.	5	.	3	6	.	7	
	.	1	2	3	
	1	2	.	3	.	4	.	7	.	8	6	.	5	9	.	10	
A6	.	1	2	4	5	7	6	3	8	.	9	.	10	
A7	.	1	2	4	.	5	3	6	.	7	
	.	1	2	3	
A8	1	2	4	5	6	7	3	8	.	9	
A9	.	.	.	1	.	.	4	.	.	3	.	2	5	
	1	2	5	.	7	6	4	.	3	8	10	9	11	13	12	14	15	16	17	.	18	.	.	.	19		
	1	.	.	2	.	.	4	6	.	7	3	.	5	9	8	10	12	11	13	14	15	16	.	17	18		
	1	2	3	4	5	6	7	8	9	10	11	.	12	
	1	2	.	3	4
	1	.	.	2
	1	.	.	2

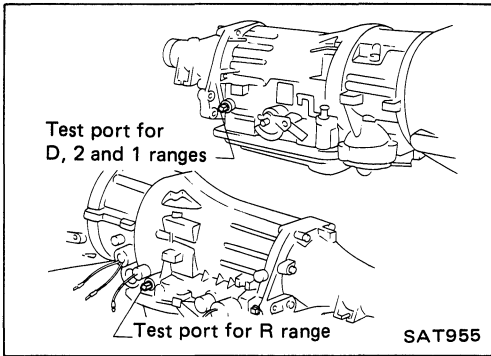

Pressure Testing

- Location of line pressure test port.

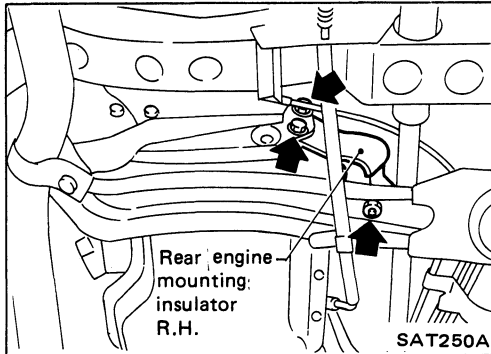

1. Install pressure gauge to line pressure port.
 - (1) Support transmission with a jack.
 - (2) Remove rear engine mounting insulator R.H.

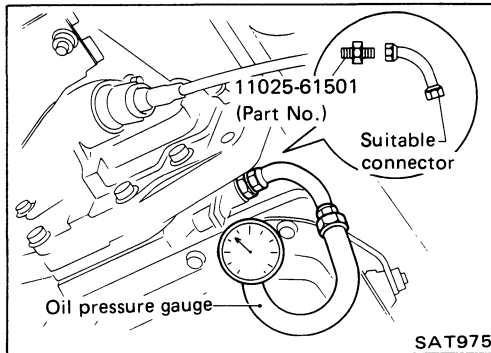

- (3) Remove line pressure plug and install oil pressure gauge and adapters.

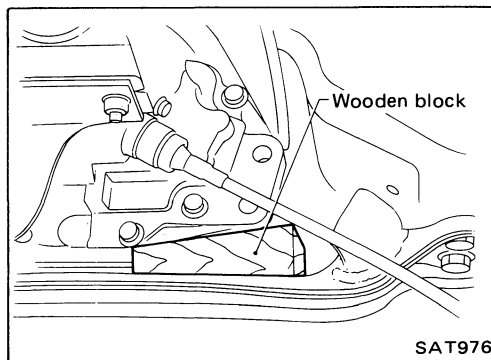

- (4) Place a suitably sized wooden block between the transmission and rear engine mounting bracket.

2. Warm up engine until engine oil and A.T.F. reach operating temperature after vehicle has been driven approx. 10 minutes.

A.T.F. temperature:

50 - 80°C (122 - 176° F)

3. Set parking brake and block wheels.
 4. Measure line pressure at idle and stall point while depressing brake pedal fully.
- **When measuring line pressure at stall point, follow the stall test procedure.**

Pressure Testing (Cont'd)

Line pressure at idling

kPa (kg/cm², psi)

Engine		Z24i	VG30i
Range			
R		412 - 549 (4.2 - 5.6, 60 - 80)	314 - 755 (3.2 - 7.7, 46 - 109)
D		314 - 373 (3.2 - 3.8, 46 - 54)	294 - 392 (3.0 - 4.0, 43 - 57)
2		412 - 971 (4.2 - 9.9, 60 - 141)	510 - 1,147 (5.2 - 11.7, 74 - 166)
1		314 - 373 (3.2 - 3.8, 46 - 54)	294 - 392 (3.0 - 4.0, 43 - 57)

Line pressure at stall testing

kPa (kg/cm², psi)

Engine		Z24i	VG30i
Range			
R		1,402 - 1,589 (14.3 - 16.2, 203 - 230)	2,059 - 2,354 (21.0 - 24.0, 299 - 341)
D		971 - 1,089 (9.9 - 11.1, 141 - 158)	1,079 - 1,275 (11.0 - 13.0, 156 - 185)
2		902 - 1,089 (9.2 - 11.1, 131 - 158)	1,108 - 1,304 (11.3 - 13.3, 161 - 189)
1		971 - 1,089 (9.9 - 11.1, 141 - 158)	1,079 - 1,275 (11.0 - 13.0, 156 - 185)

Pressure Testing (Cont'd)

JUDGMENT BY MEASURING LINE PRESSURE

If line pressure does not rise, first check to make sure that vacuum hose is connected properly.

- 1) When line pressure is low at all positions, the problem may be due to:
 - Wear on interior of oil pump
 - Oil leakage at or around oil pump, control valve body, transmission case or governor
 - Sticking pressure regulator valve
 - Sticking pressure modifier valve
- 2) When line pressure is low at a particular position, the problem may be due to the following:
 - If oil leaks at or around rear clutch or governor, line pressure is low in "D", "2" or "1" range but is normal in "R" range.
 - If oil leaks at or around low and reverse brake circuit, line pressure becomes low in "R" or "P" range but is normal in "D", "2" or "1" range.
- 3) When line pressure is high, pressure regulator valve may have stuck.

Stall Testing

The stall test is an effective method of testing clutch and band holding ability, torque converter one-way clutch operation, and engine performance. A stall test should only be performed as a last resort because of the high fluid temperature it generates and the excessive load it places on the engine and transmission.

CAUTION:

- a. Transmission and engine fluid levels should always be checked and fluid added as needed.
- b. Run engine to attain proper warm-up.
- c. During test, never hold throttle wide-open for more than 5 seconds.
- d. Do not test more than two gear ranges without driving vehicle to cool off engine and transmission.

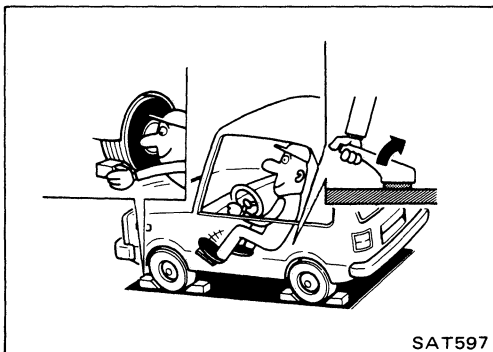

STALL TEST PROCEDURE

1. Set parking brake and block wheels.
2. Install a tachometer where it can be seen by driver during test.
3. Start engine and place selector lever in "D" range.

Stall Testing (Cont'd)

4. Apply foot brake and accelerate to wide-open throttle.
5. Quickly note the engine stall speed and immediately release throttle.

Stall revolution:

Z24i: 1,800 - 2,100 rpm

VG30i: 2,000 - 2,300 rpm

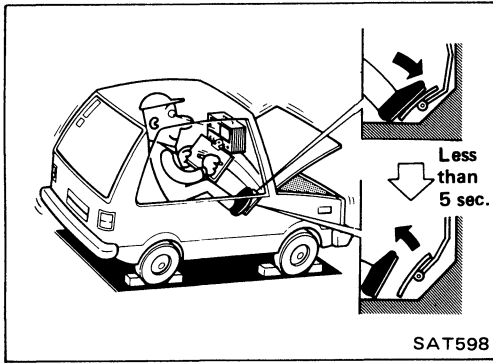

6. Shift selector lever to "N".
7. Cool off A.T.F.
8. Perform stall tests in the same manner as in steps 3 through 7 with selector lever in "1" and "R", respectively.
9. If stall revolution is out of specified value, perform troubleshooting following Stall Test Analysis on the next page.

Stall Testing (Cont'd)

STALL TEST ANALYSIS

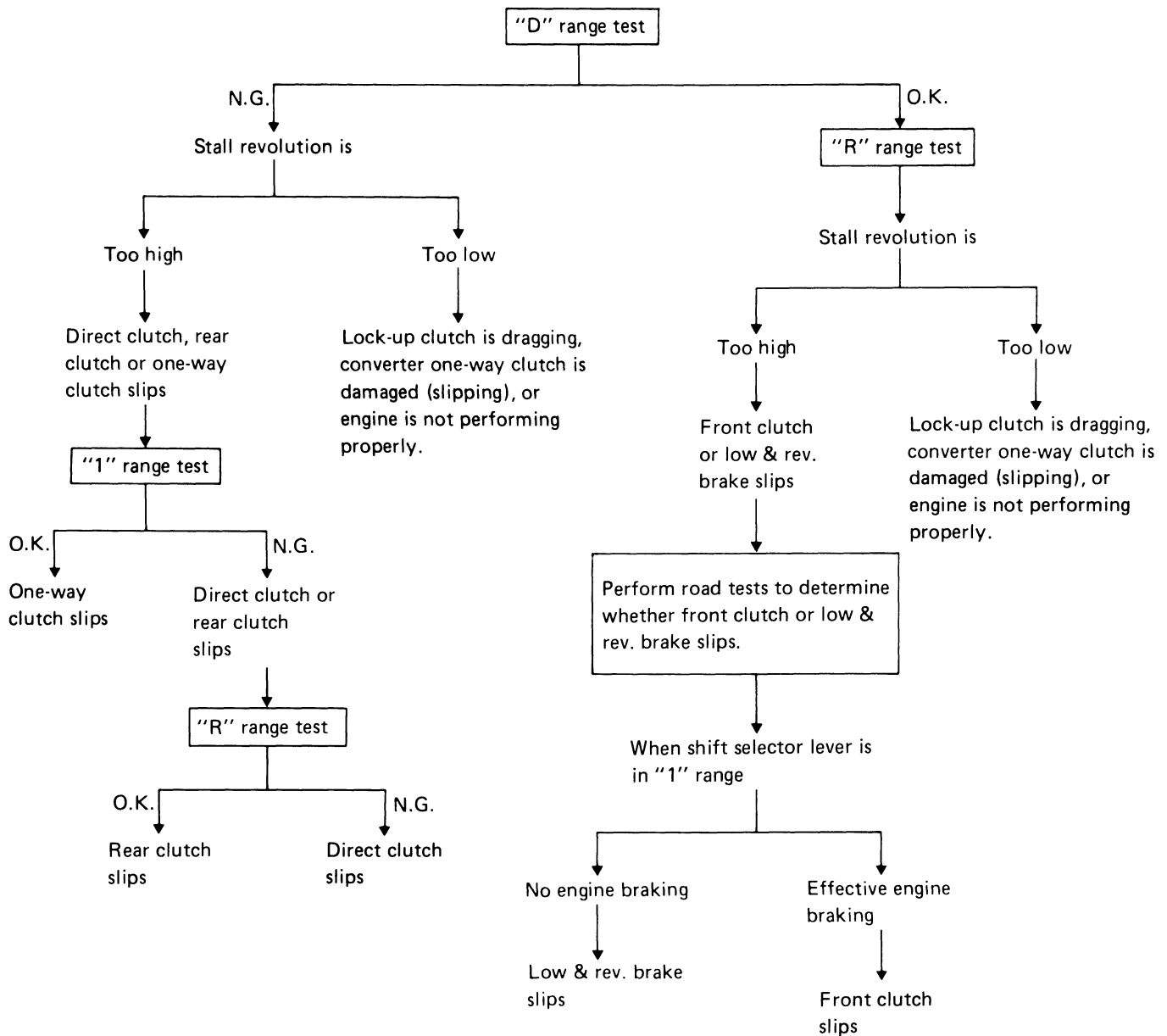

If converter one-way clutch is frozen, vehicle will have poor high speed performance and low engine rpm when it is raced in "N" range. If converter one-way clutch is slipping, vehicle will be sluggish up to 50 or 60 km/h (30 or 40 MPH).

Electrical System/Schematic

Z24i engine

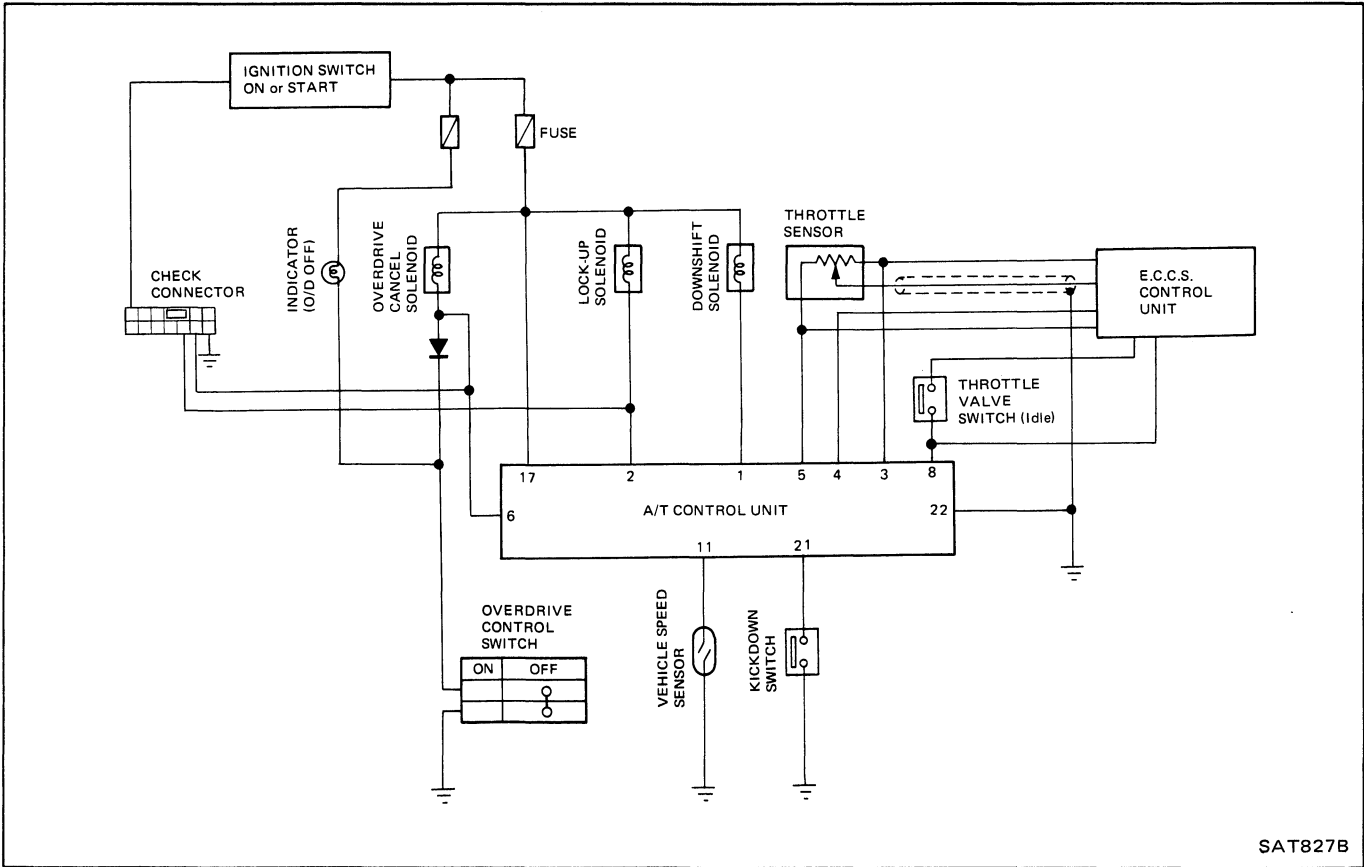

SAT827B

VG30i engine

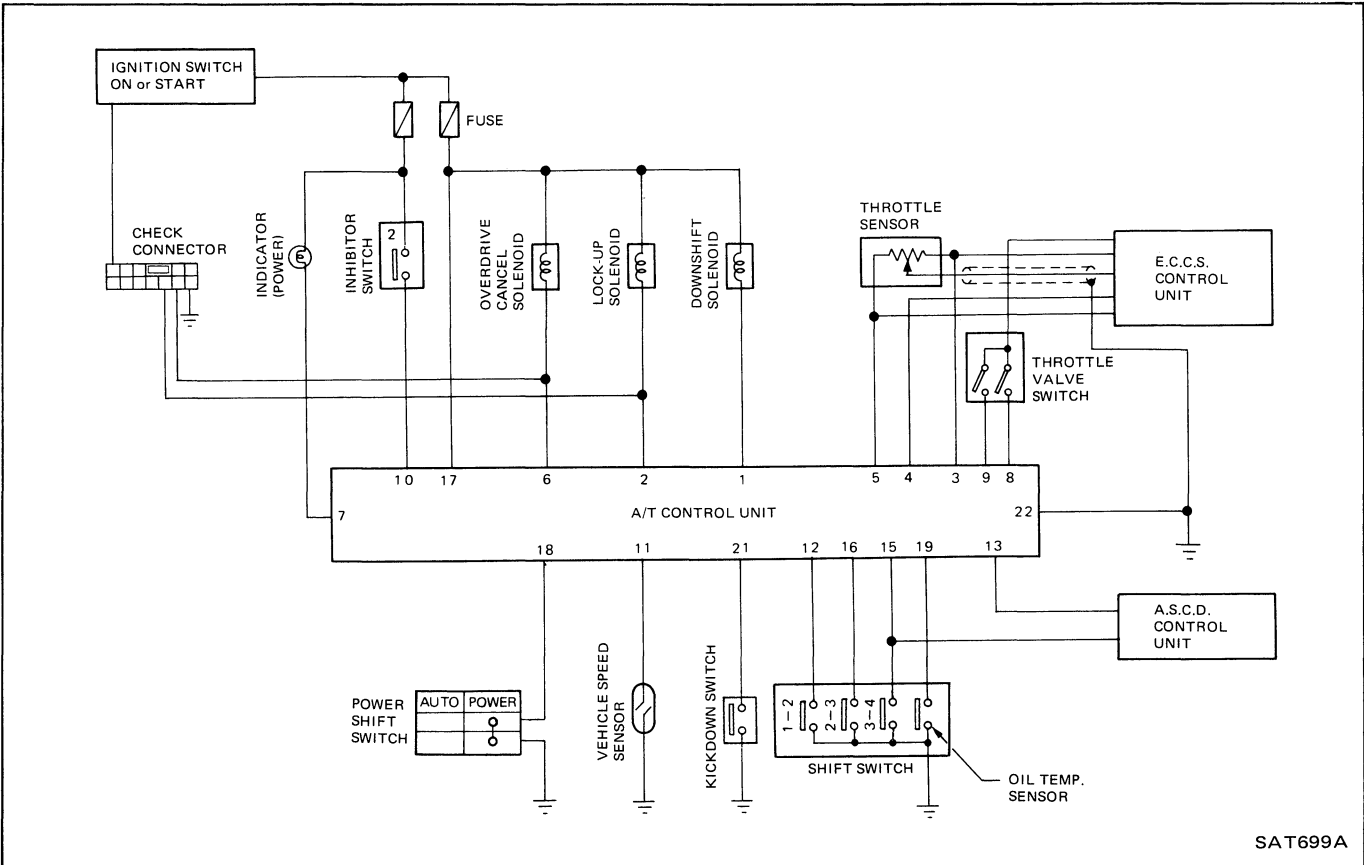

SAT699A

Z24i engine

Electrical System/Wiring Diagram

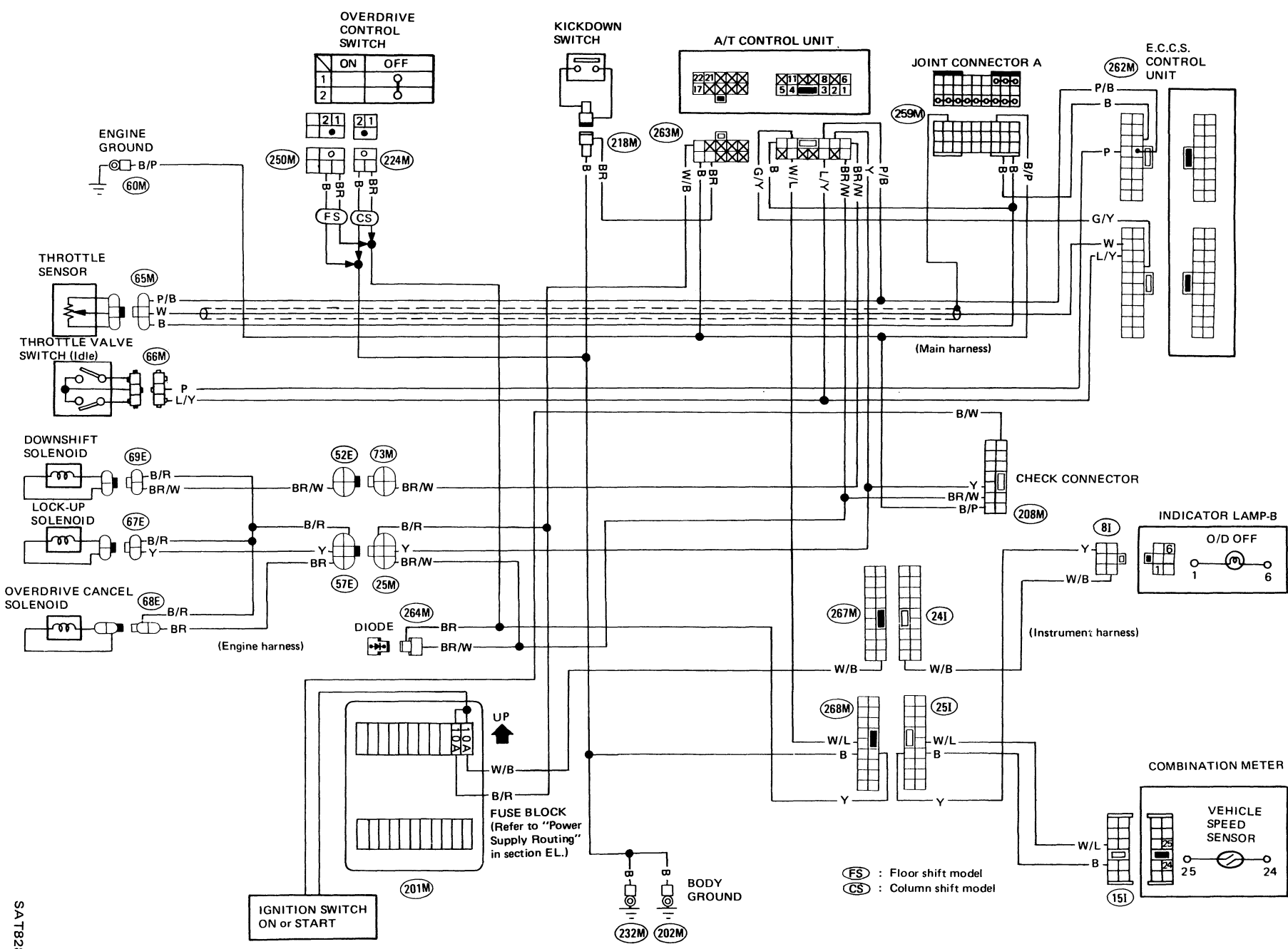

AT-28

SAT828B

Electrical System/Wiring Diagram (Cont'd)

V/G30i engine

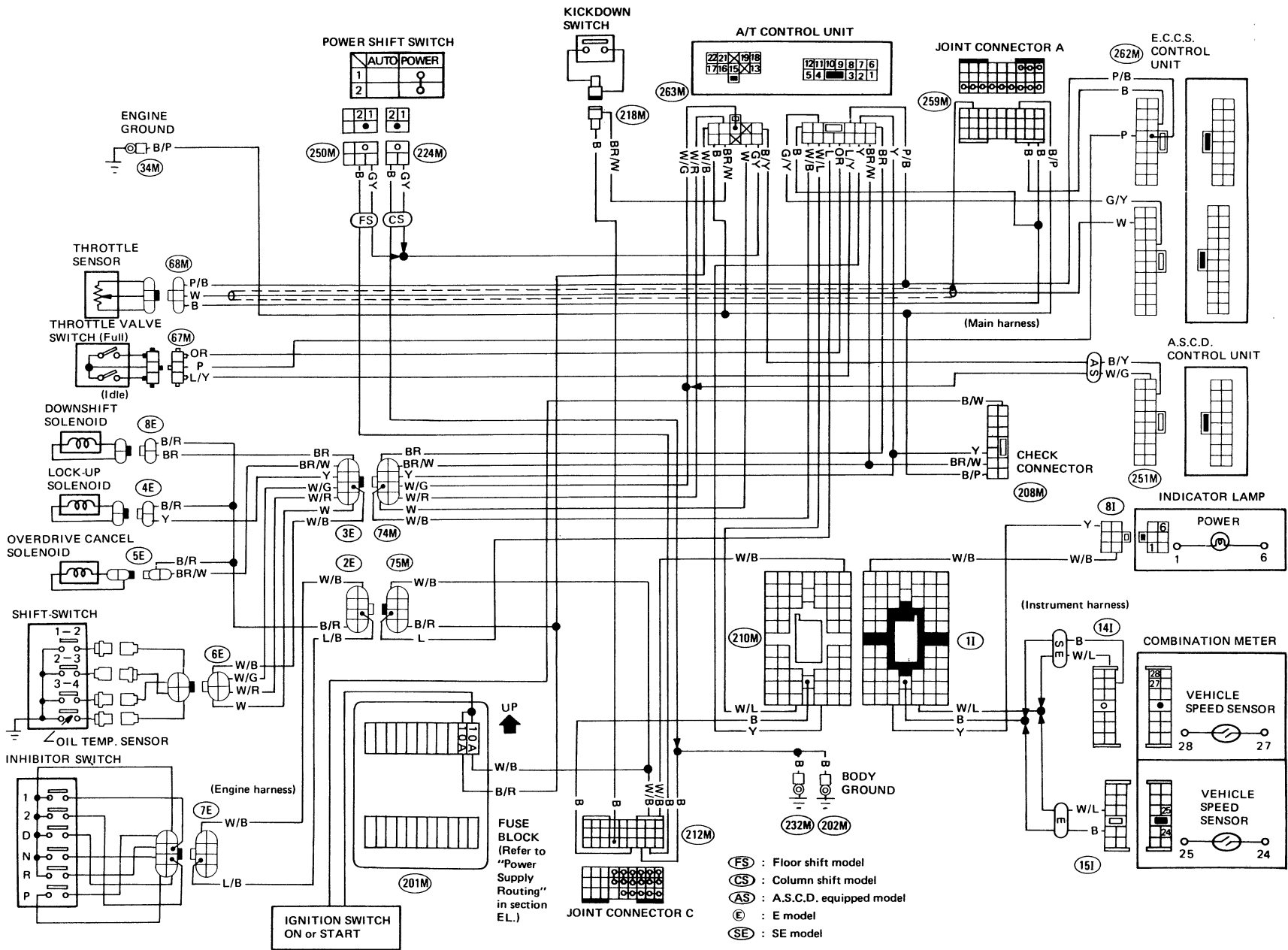

AT-29

SAT829B

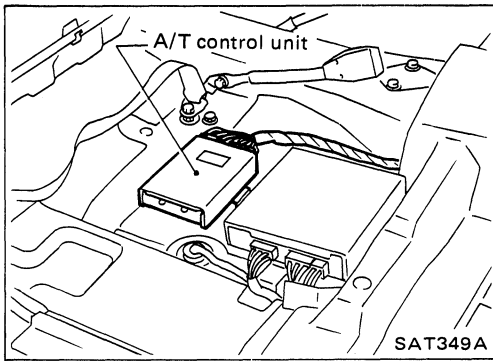

LOCATION OF LOCK-UP CONTROL UNIT

- Truck model: Under R.H. front seat.

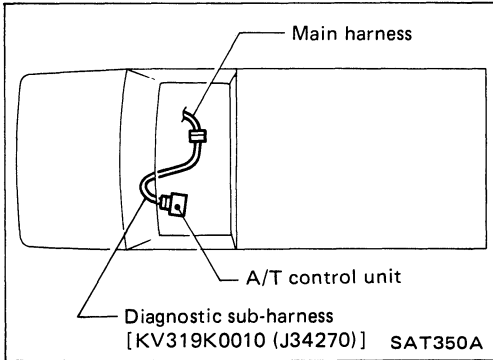

HOW TO USE DIAGNOSTIC SUB-HARNESS

To ease checking of voltage and continuity on A/T control unit, connect diagnostic sub-harness [KV319K0010 (J34270)] between A/T control unit and main harness.

Customer Complaint (Z24i engine): No lock-up

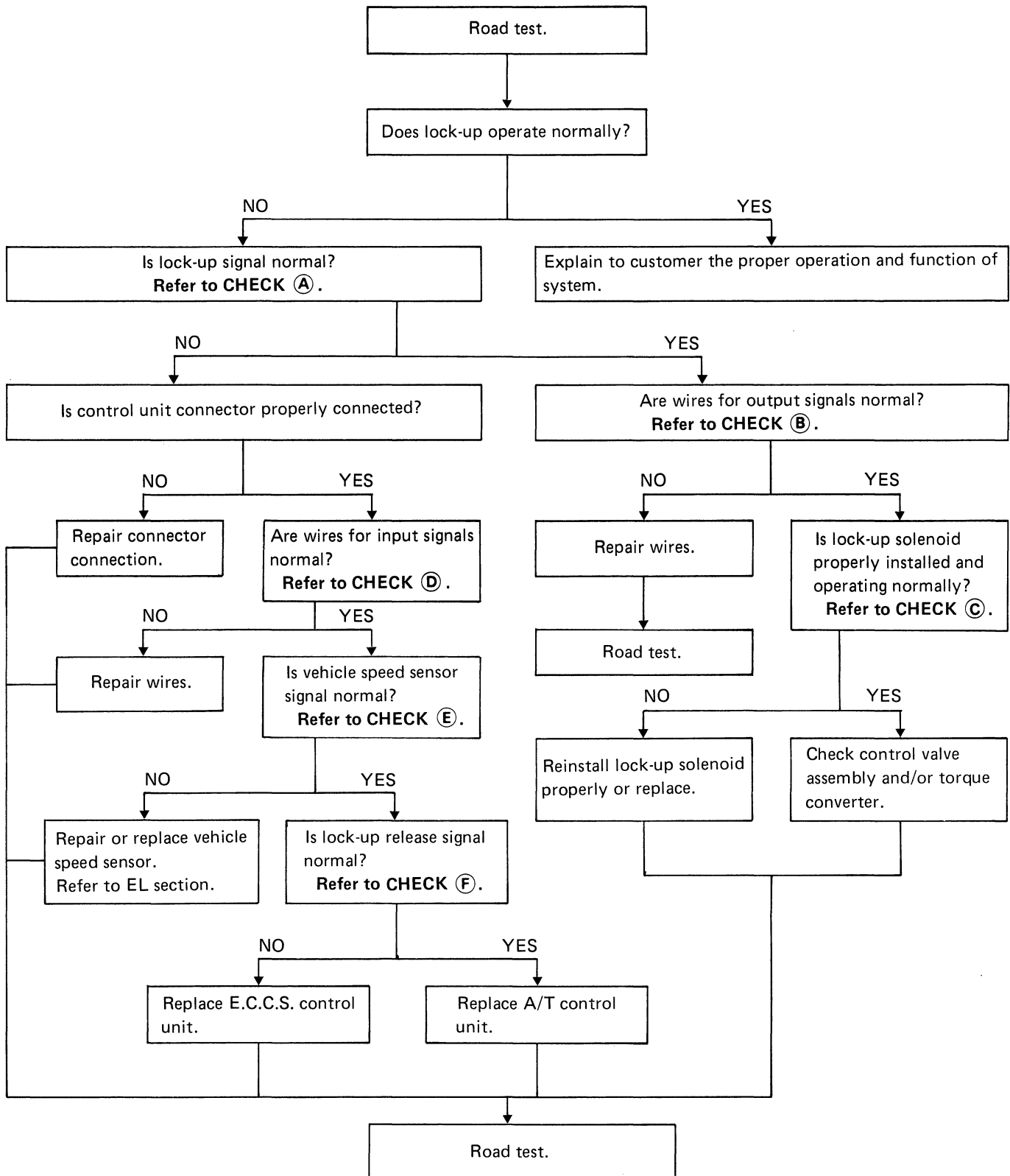

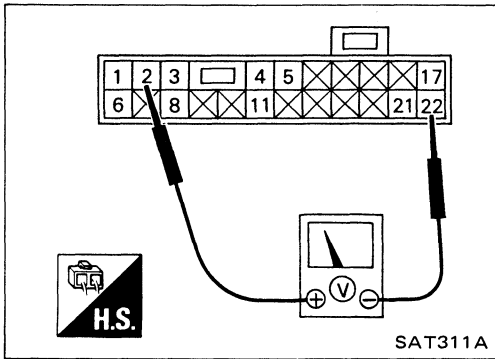

CHECK ①

- Measure voltage while driving vehicle in "D" range.
 Lock-up solenoid is turned ON → 1V or less
 Lock-up solenoid is turned OFF → Battery voltage

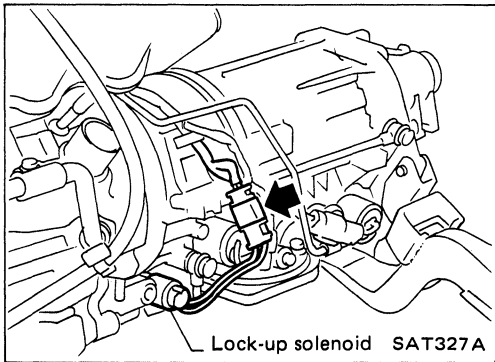

CHECK ②

Check if connector between control unit and lock-up solenoid is properly connected. Also, check connector for continuity.

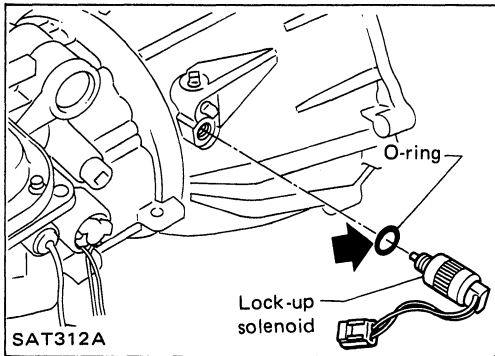

CHECK ③

- Check if O-ring is installed to tip of solenoid.

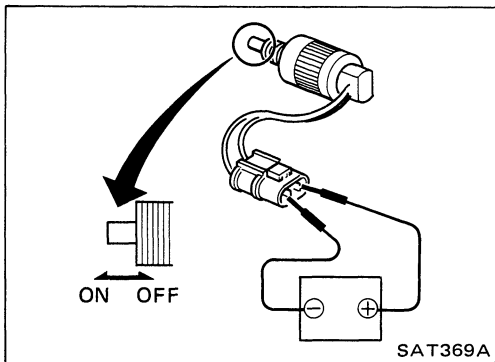

- Check operation of lock-up solenoid by applying battery voltage.

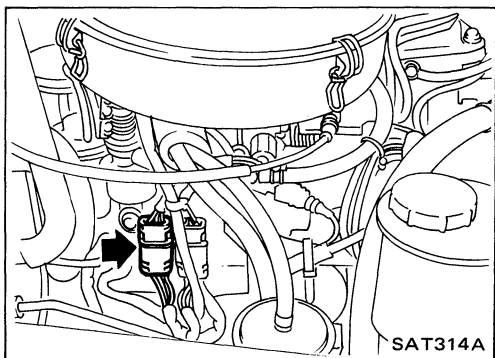

CHECK ④

[Throttle sensor]

- Check connection of connector.
- Check continuity of harness.

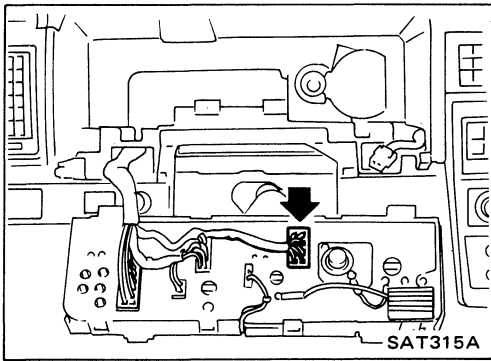

[Vehicle speed sensor]

- Check connection of connector.
- Check continuity of harness.

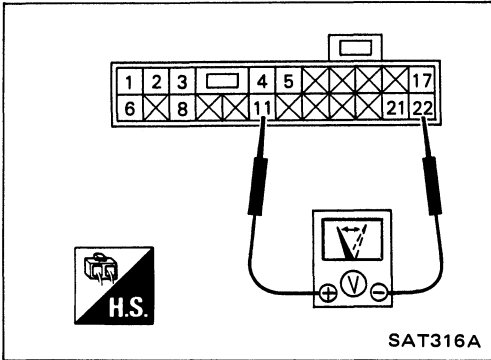

CHECK ⑤

- Turn ignition switch ON and move vehicle over 1 m (3 ft) at very low speed.
Voltage must vary from 0V to approx. 5V.

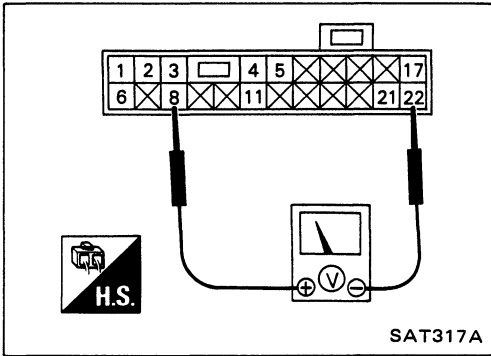

CHECK ⑥

- Turn ignition switch ON.
Full-close throttle → Approx. 4.8V or more
Except full-close throttle → Approx. 0V

Customer Complaint (Z24i engine): No shifting into O.D. gear

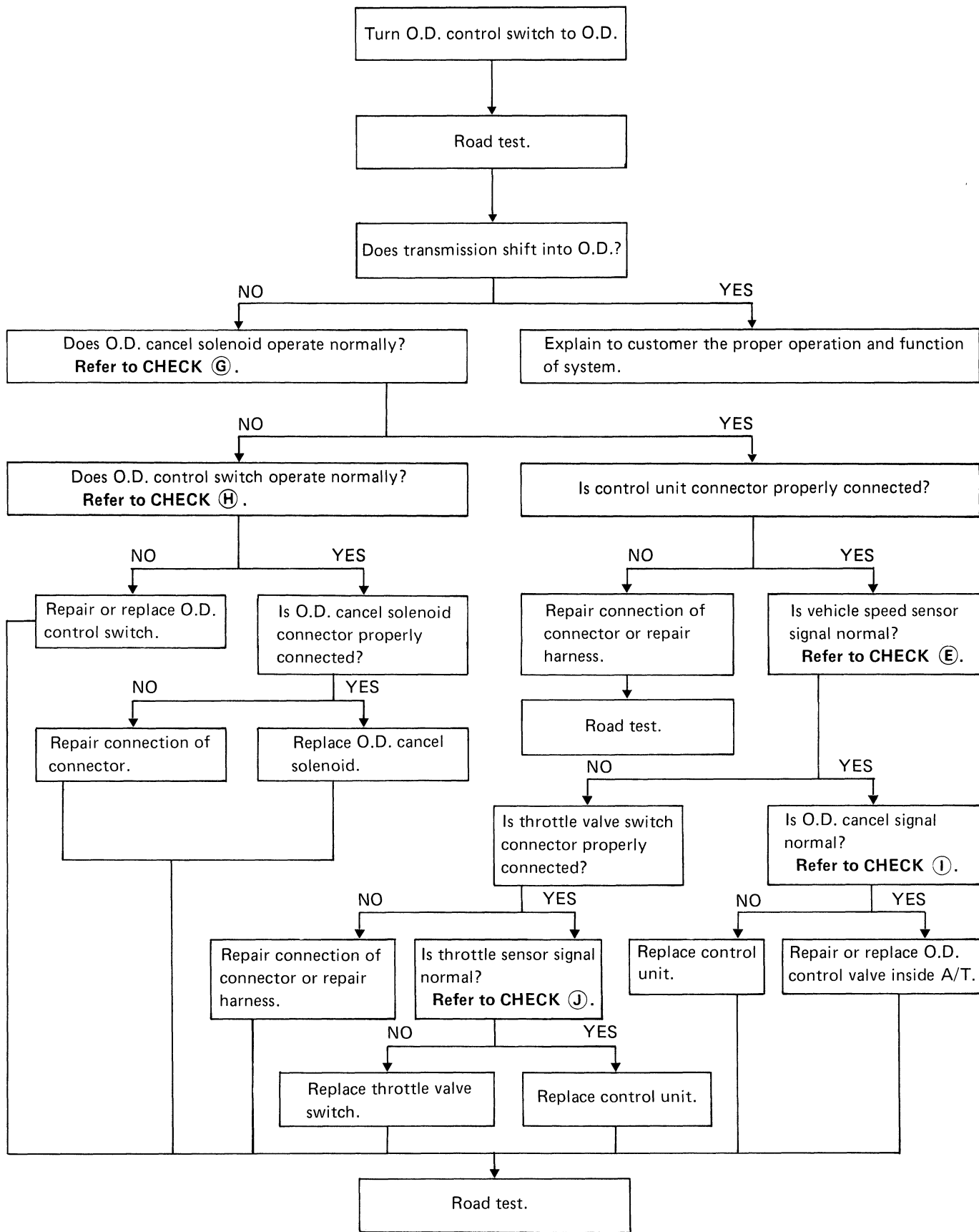

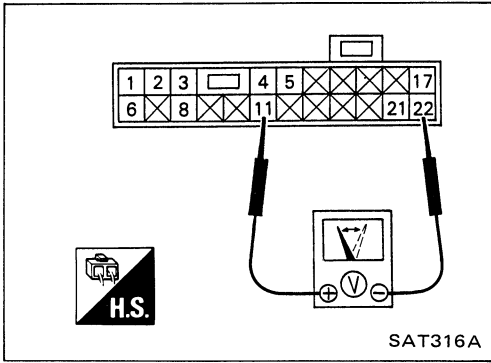

CHECK ⑤

- Turn ignition switch ON and move vehicle over 1 m (3 ft) at very low speed.
Voltage must vary from 0V to approx. 5V.

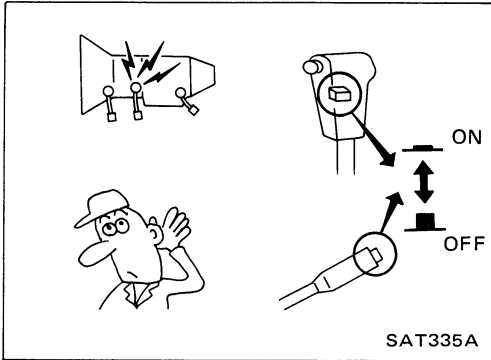

CHECK ⑥

- Turn ignition switch ON.
- Turn O.D. control switch to "OFF" and "ON" and check to see if O.D. cancel solenoid clicks.

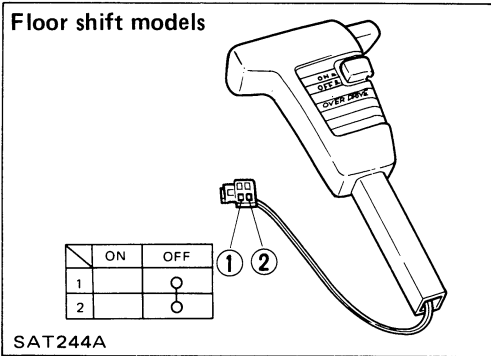

CHECK ⑧

- Check continuity between terminals.

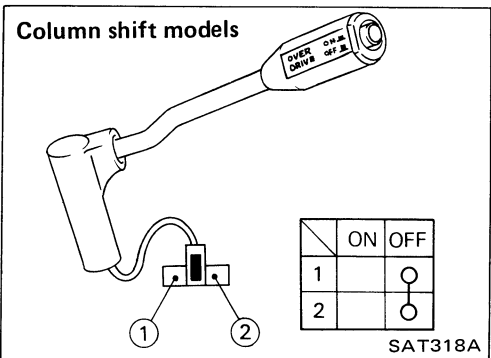

CHECK ⑩

- Measure voltage while driving vehicle in O.D. gear.
Accelerator pedal is depressed 3/4 or more → 0V
Accelerator pedal is released to 1/2 or less after depressing it → Battery voltage

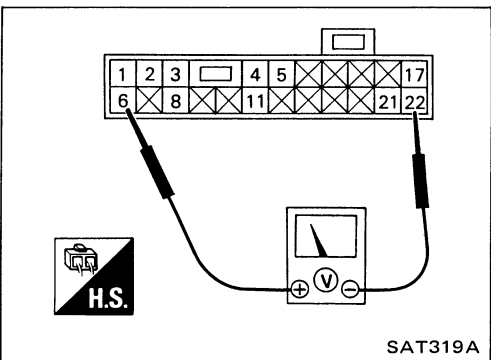

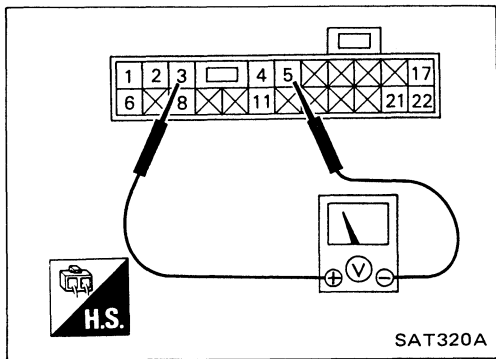

CHECK ①

[Throttle sensor power source]

- Turn ignition switch ON.
Approx. 5V at all times

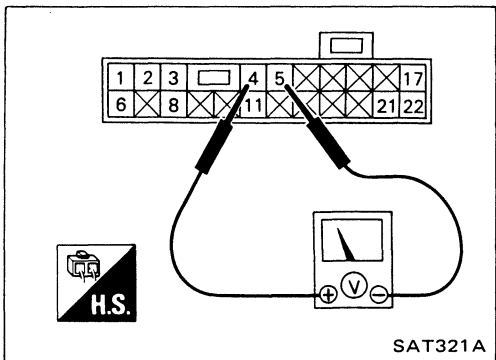

[Throttle sensor signal]

- Turn ignition switch ON.
Full-close throttle → Approx. 0.3V
Full-open throttle → Approx. 3V

Customer Complaint (Z24i engine): Shifting point is too high or too low

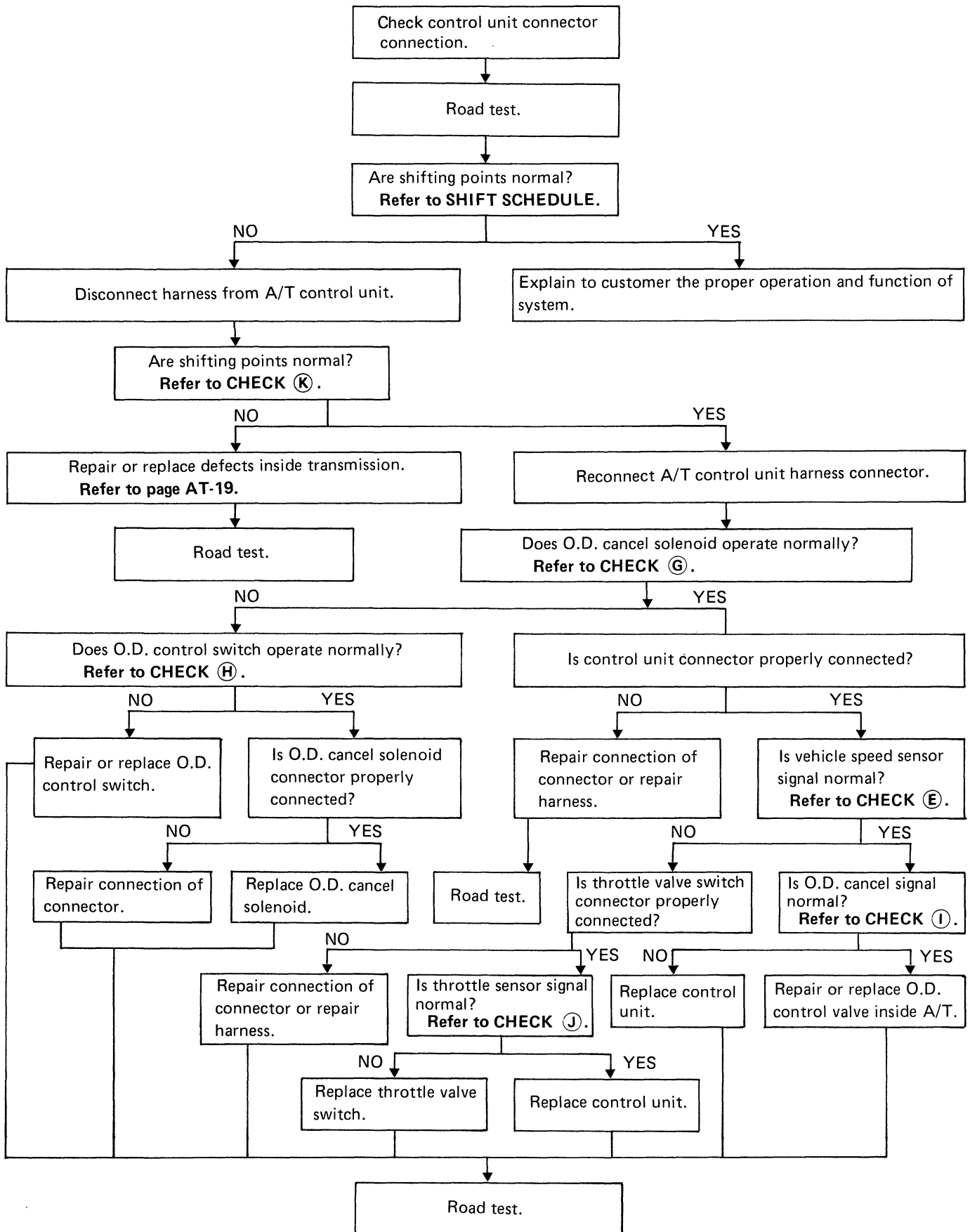

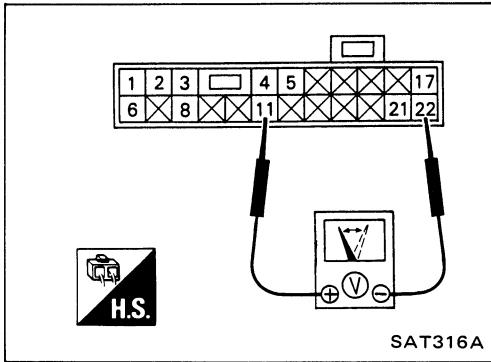

CHECK ⑤

- Turn ignition switch ON and move vehicle over 1 m (3 ft) at very low speed.
Voltage must vary from 0V to approx. 5V.

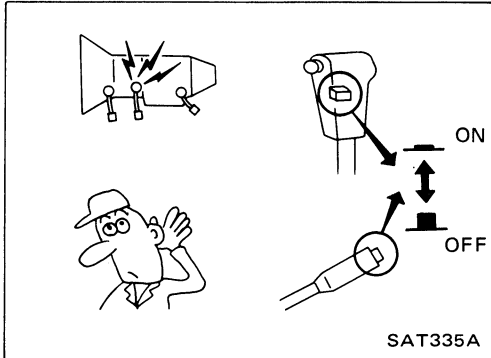

CHECK ⑥

- Turn ignition switch ON.
- Turn O.D. control switch to "OFF" and "ON" and check to see if O.D. cancel solenoid clicks.

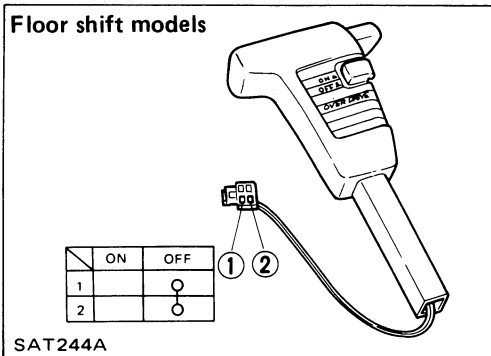

CHECK ⑦

- Check continuity between terminals.

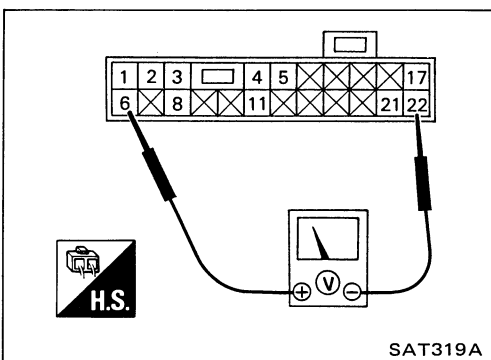
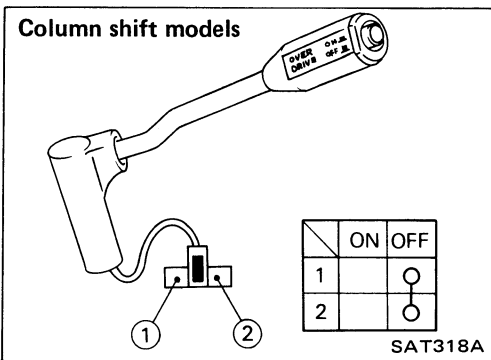

CHECK ⑧

- Measure voltage while driving vehicle in O.D. gear.
Accelerator pedal is depressed 3/4 or more → 0V
Accelerator pedal is released to 1/2 or less after depressing it → Battery voltage

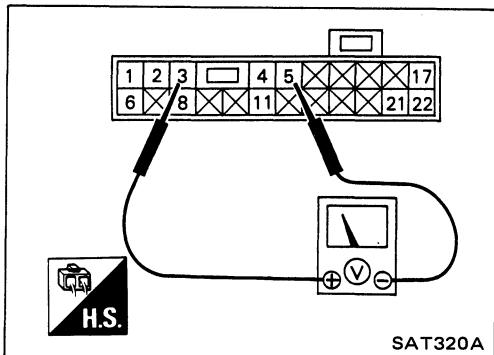

CHECK ①

[Throttle sensor power source]

- Turn ignition switch ON.
Approx. 5V at all times

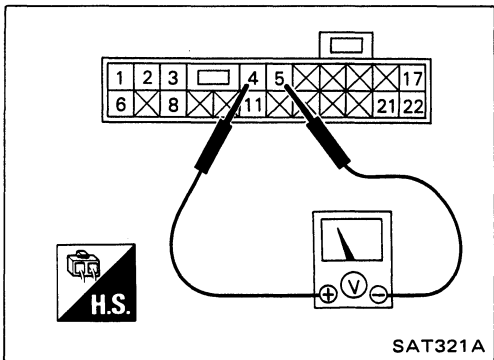

[Throttle sensor signal]

- Turn ignition switch ON.
Full-close throttle → Approx. 0.3V
Full-open throttle → Approx. 3V

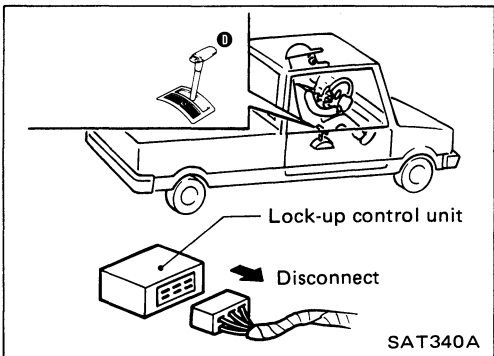

CHECK ②

Throttle position	Gearshift	Vehicle speed km/h (MPH)
Full throttle	D ₁ → D ₂	53 - 56 (33 - 35)
	D ₂ → D ₃	97 - 105 (60 - 65)
	D ₃ → D ₄	—
	D ₄ → D ₃	—
	D ₃ → D ₂	77 - 85 (48 - 53)
	D ₂ → D ₁	40 - 47 (25 - 29)

Customer Complaint (Z24i engine): Transmission does not kickdown

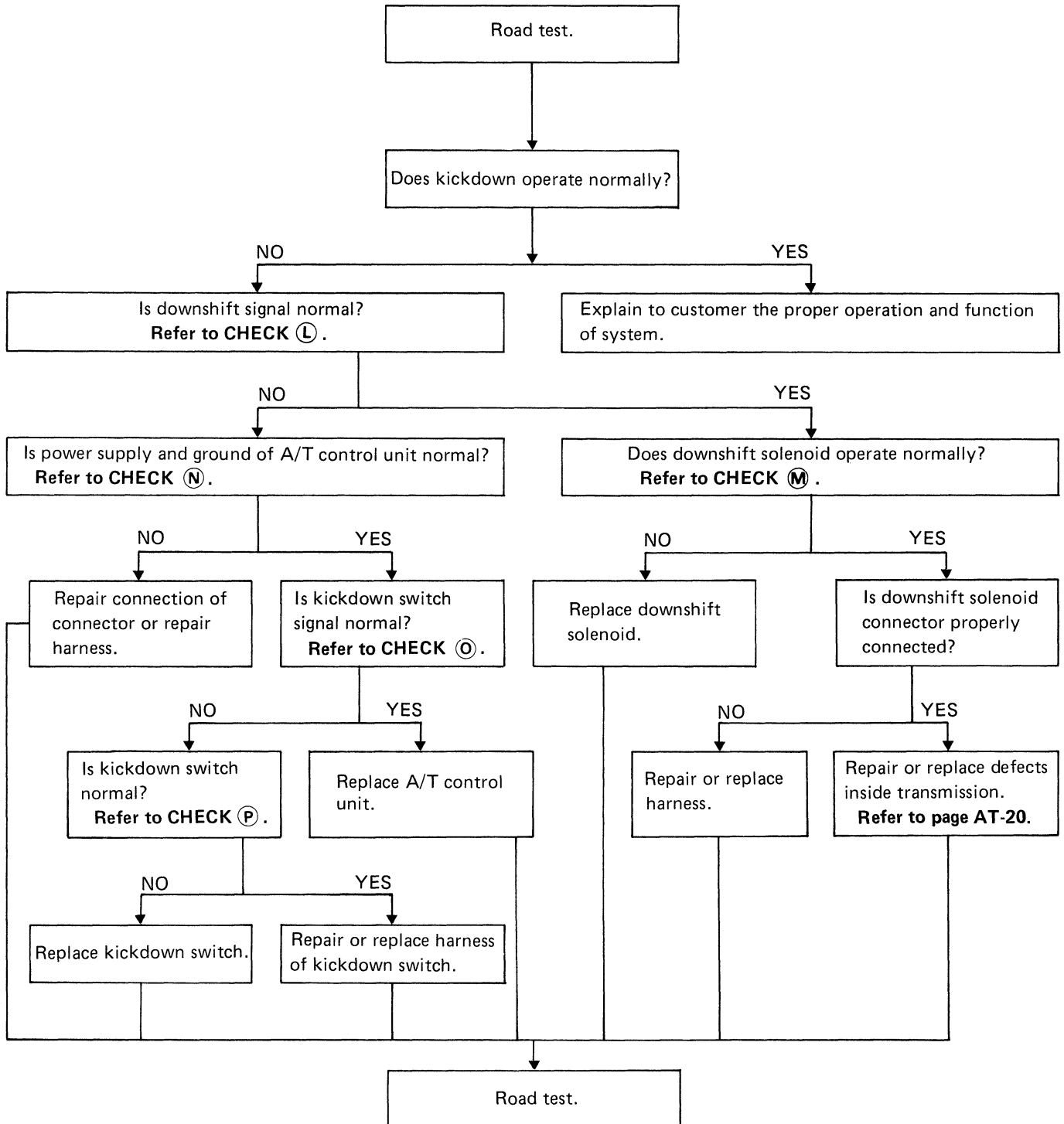

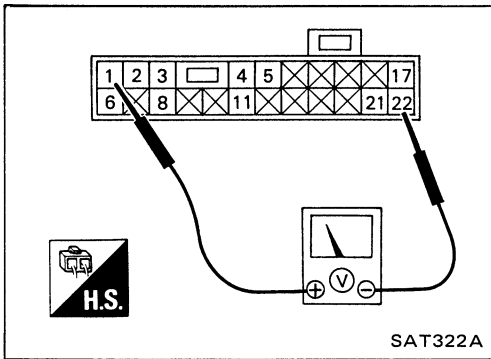

CHECK ㊀

- Measure voltage while driving vehicle at full-throttle.
 0 ~ Approx. 55 km/h (34 MPH) → Approx. 0V
 Approx. 1 second after 55 km/h (34 MPH) → Battery voltage

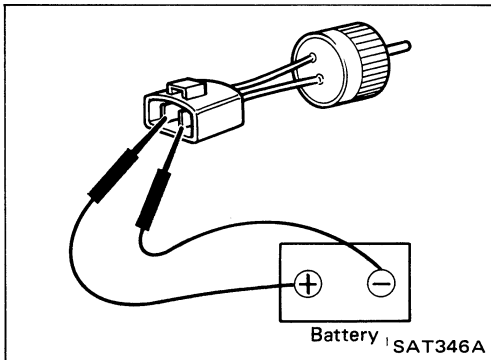

CHECK ㊁

- Check operation of downshift solenoid by applying battery voltage.

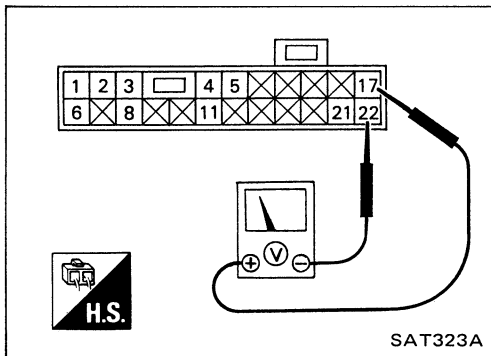

CHECK ㊂

- Turn ignition switch ON.
 Battery voltage at all times

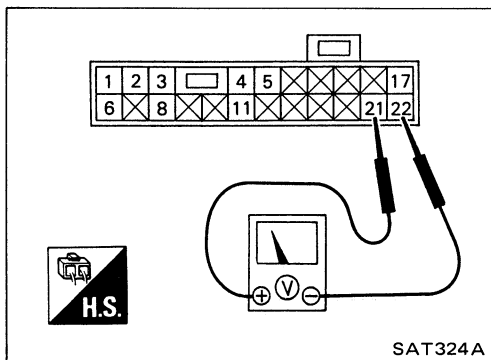

CHECK ㊃

- Turn ignition switch ON.
 Accelerator pedal is fully depressed → Approx. 0V
 Accelerator pedal is released → Approx. 5V

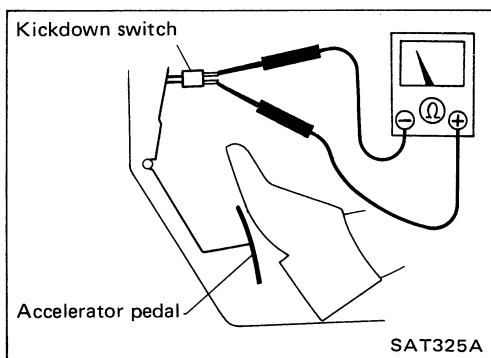

CHECK ㊄

- Turn ignition switch ON.
 Accelerator pedal is fully depressed → 0Ω
 Accelerator pedal is released → ∞

Customer Complaint (Z24i engine): Kickdown occurs when high speed driving, as a result engine is overrevved

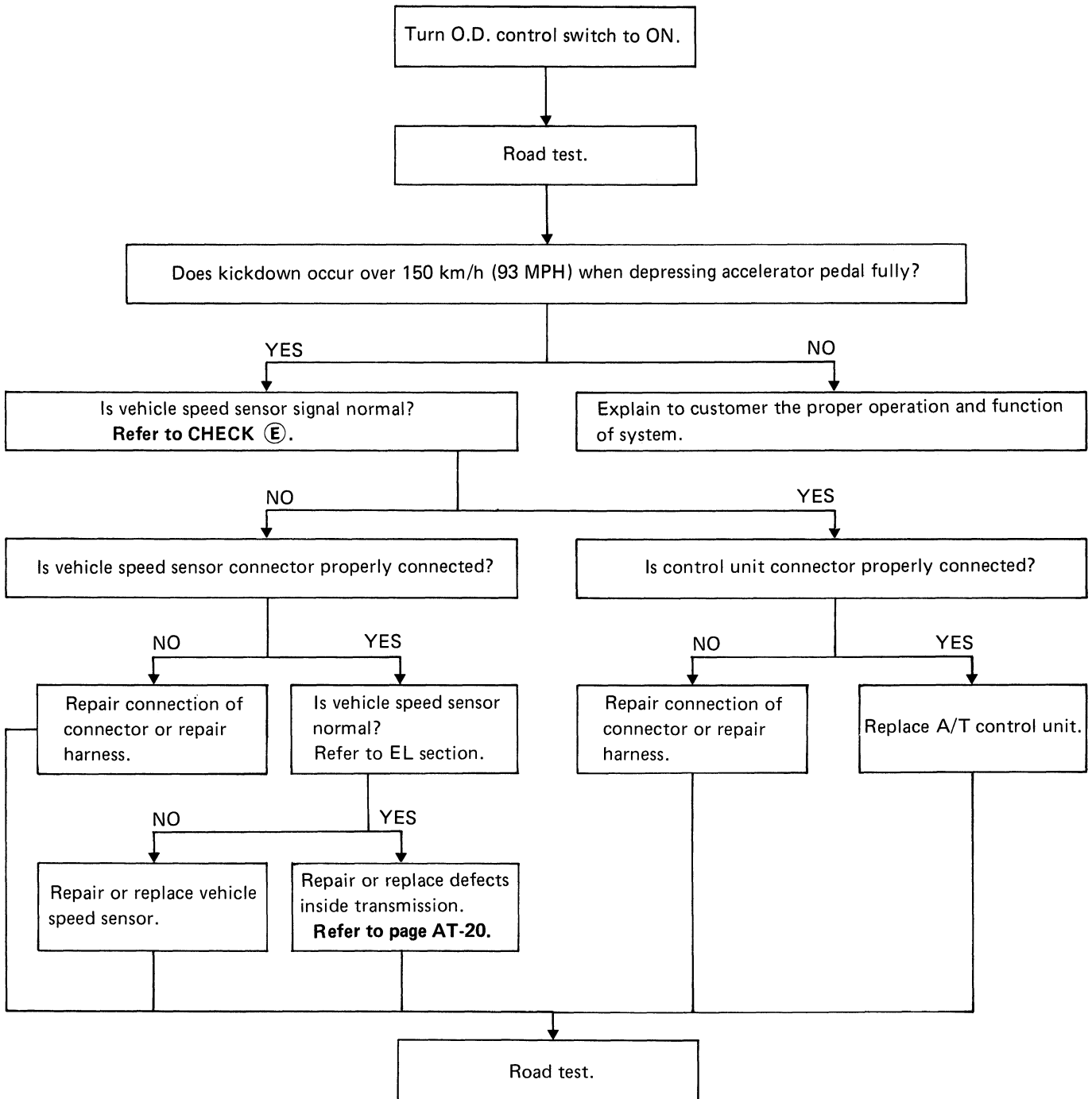

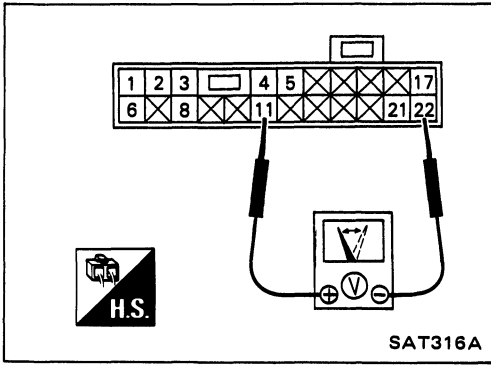

CHECK ③

- Turn ignition switch ON and move vehicle over 1 m (3 ft) at very low speed.

Voltage must vary from 0V to approx. 5V.

Customer Complaint (VG30i) : No lock-up

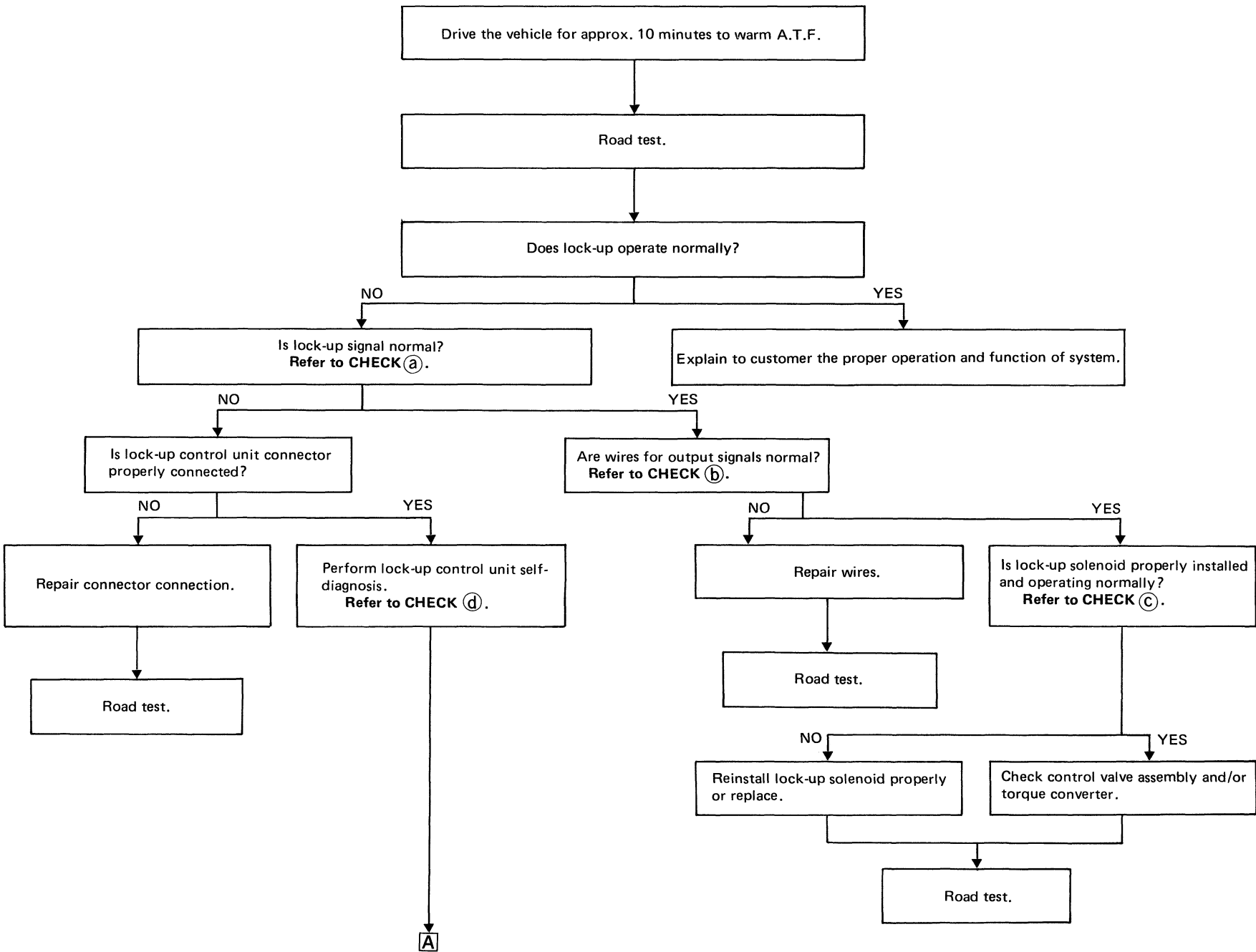

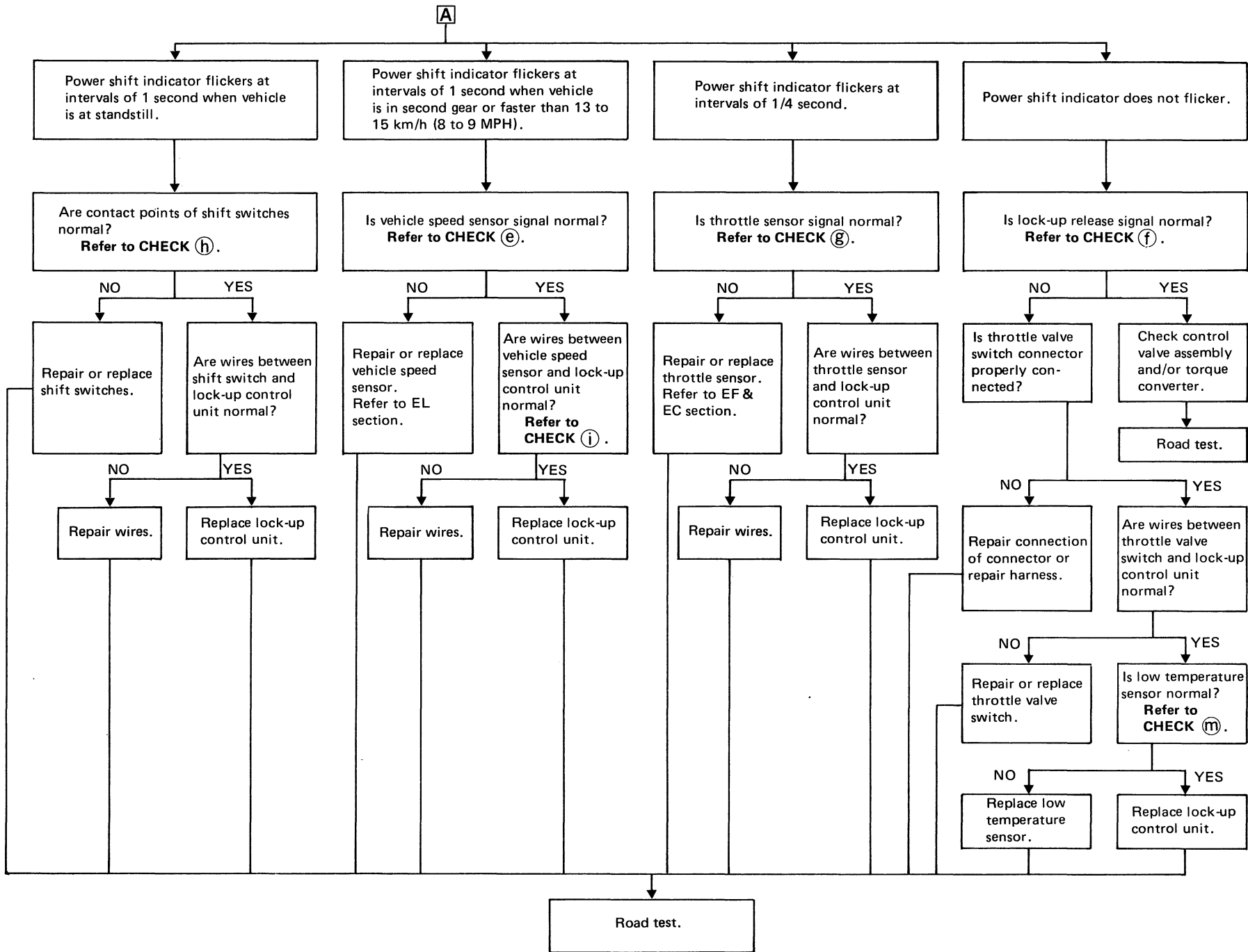

AT-45

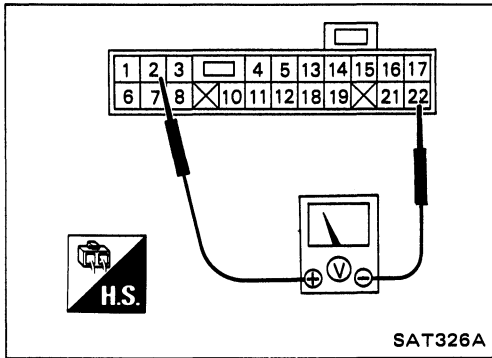

CHECK ①

- Measure voltage while driving vehicle in "D" range.
 Lock-up solenoid is turned ON → 1V or less
 Lock-up solenoid is turned OFF → Battery voltage

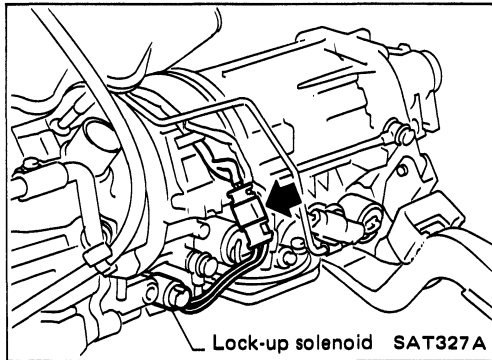

CHECK ②

Check if connector between control unit and lock-up solenoid is properly connected. Also, check connector for continuity.

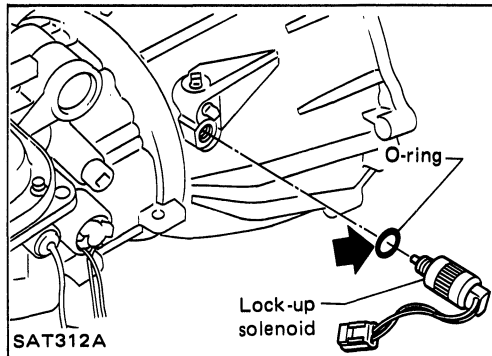

CHECK ③

- Check if O-ring is installed to tip of lock-up solenoid.

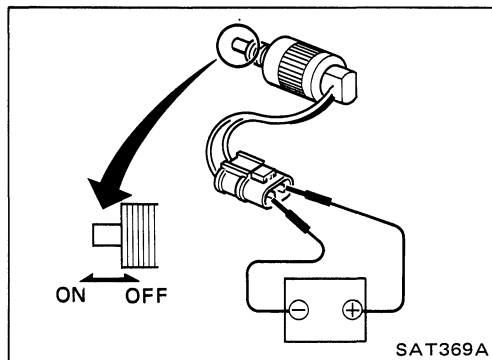

- Check operation of lock-up solenoid by applying battery voltage.

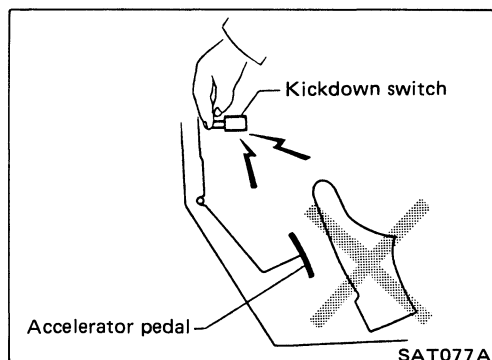

CHECK ④

Operate the self-diagnosis function as follows:

1. Turn power shift switch to "AUTO".
2. Turn the ignition switch to "ON".
Do not start the engine.
3. Operate kickdown switch by hand for at least one second.
Do not use accelerator pedal.

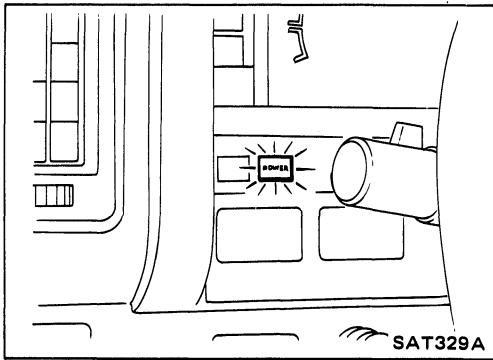

4. Start the engine and run the vehicle about 20 km/h (12 MPH), and check to see whether or not an abnormal condition exists.

When an abnormal condition exists, the power shift indicator lamp will flicker at intervals of 1 or 1/4 second.

Turning the ignition switch to "OFF" or "ACC" cancels the self-diagnosis function. If cancelled, repeat steps over again.

CHECK ⑥

- Turn ignition switch ON and move vehicle over 1 m (3 ft) at very low speed.

Voltage must vary from 0V to approx. 5V.

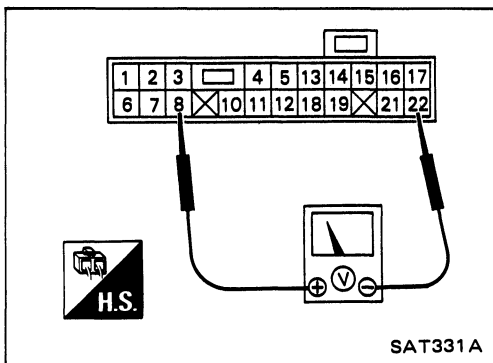
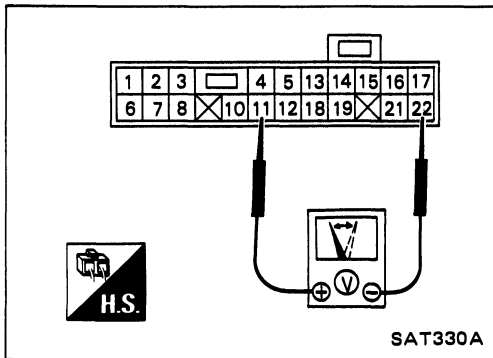

CHECK ⑦

- Turn ignition switch ON.
 Full-close throttle → 4.8V or more
 Part-open throttle → 0V

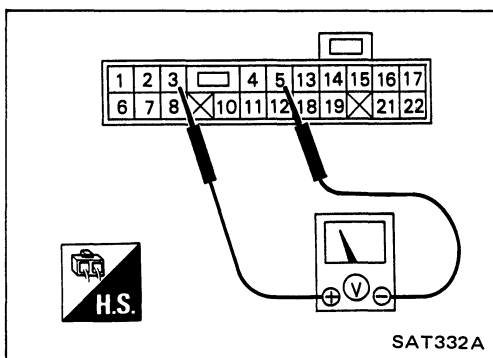

CHECK ⑧

[Throttle sensor power source]

- Turn ignition switch ON.
 Approx. 5V at all times

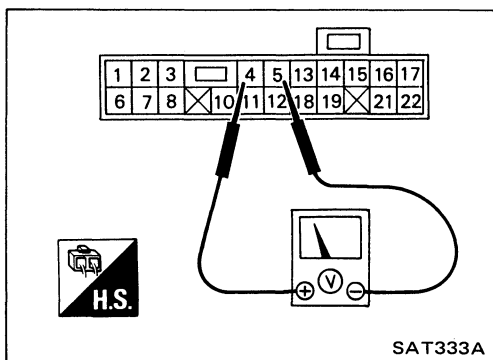

[Throttle sensor signal]

- Turn ignition switch ON.
 Full-close throttle → Approx. 0.3V
 Full-open throttle → Approx. 3V

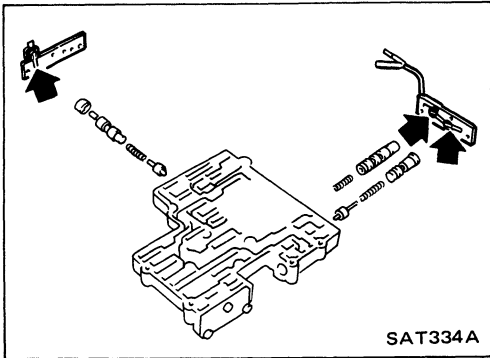

CHECK ⑧

- Check contact points of shift switches for damage.

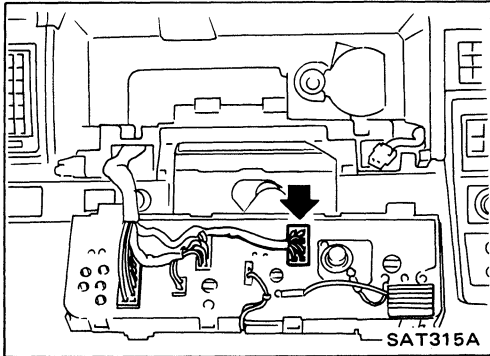

CHECK ⑨

- Check connection of vehicle speed sensor connector.
- Check wires between vehicle speed sensor and lock-up control unit.

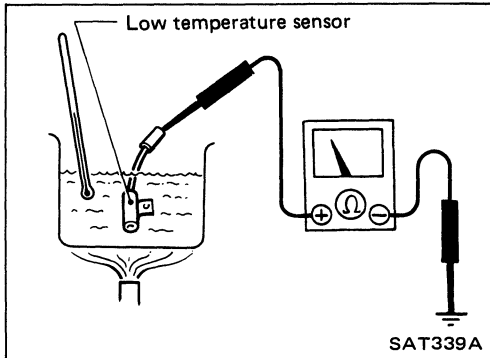

CHECK ⑩

- Check continuity on low temperature sensor.
 45°C (113°F) or more → ∞
 35°C (95°F) or less → 0Ω

Note:

Customer Complaint (VG30i) : No shifting

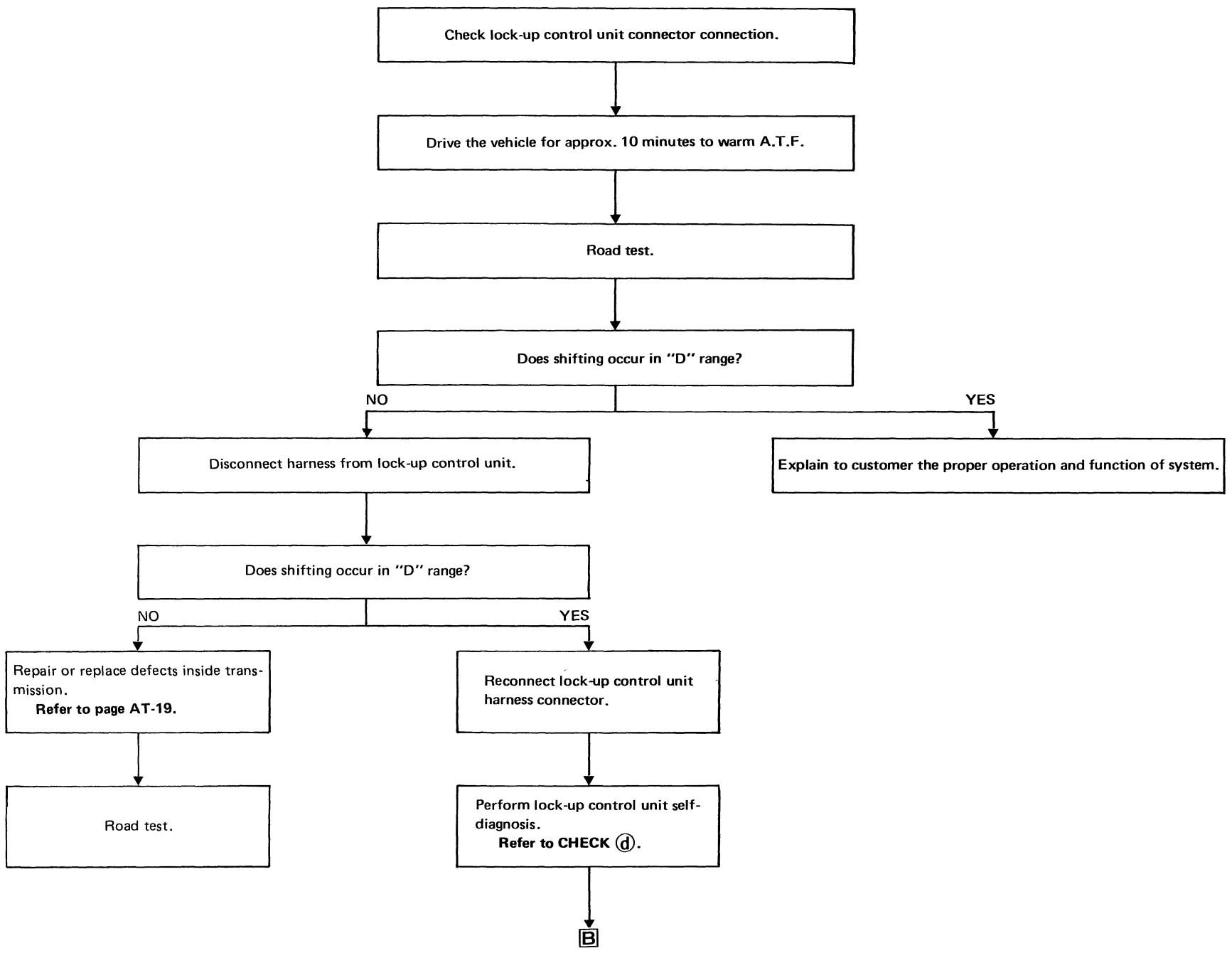

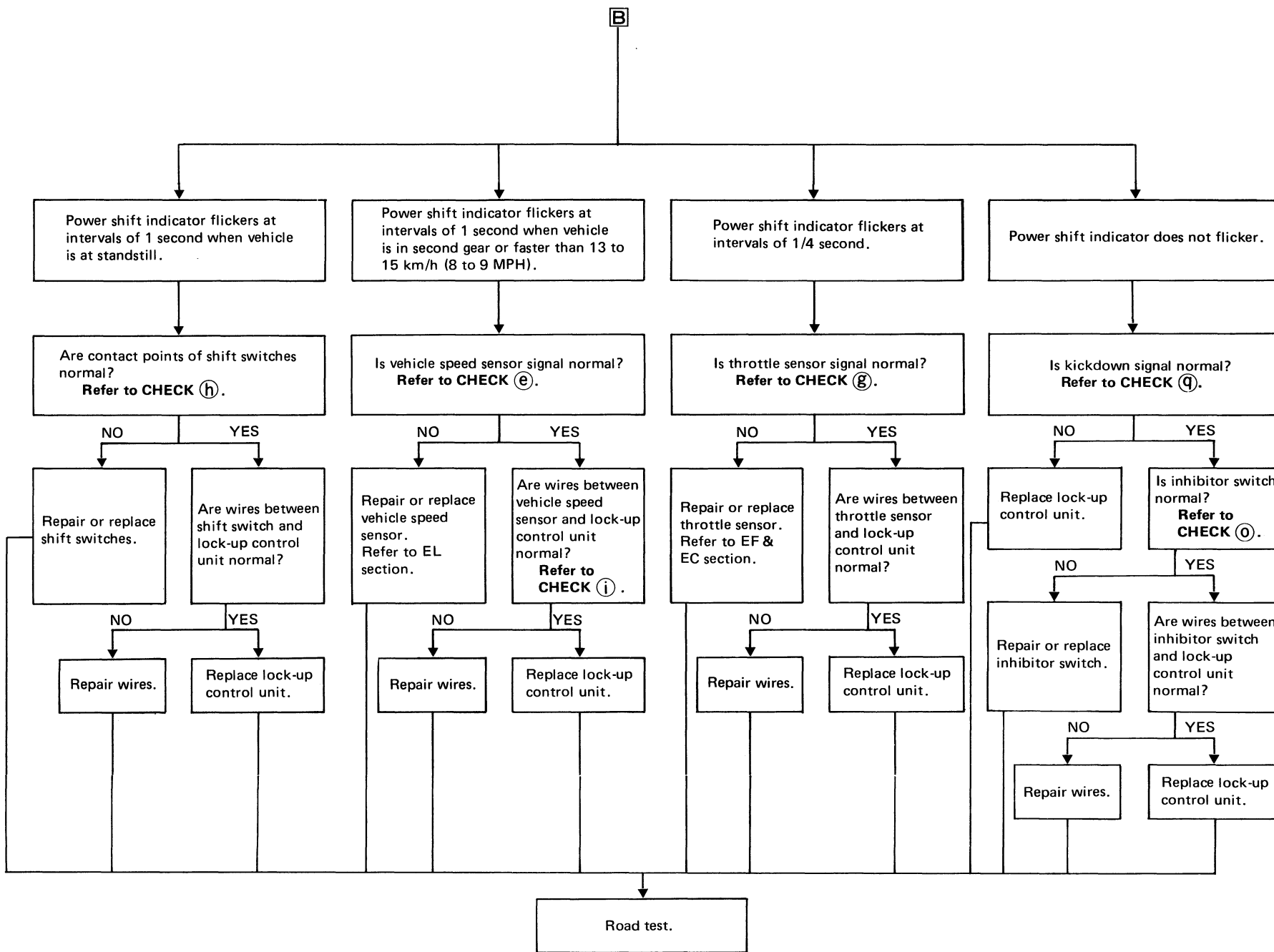

AT-51

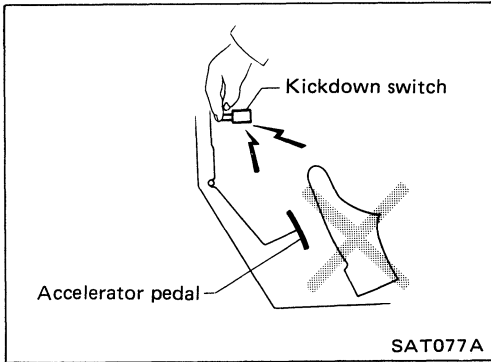

CHECK ㉔

Operate the self-diagnosis function as follows:

1. Turn power shift switch to "AUTO".
2. Turn the ignition switch to "ON".
Do not start the engine.
3. Operate kickdown switch by hand for at least one second.
Do not use accelerator pedal.

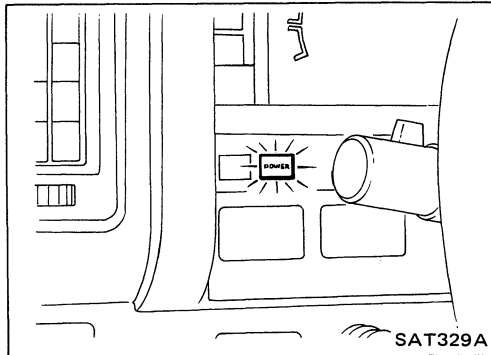

4. Start the engine and run the vehicle about 20 km/h (12 MPH), and check to see whether or not an abnormal condition exists.

When an abnormal condition exists, the power shift indicator lamp will flicker at intervals of 1 or 1/4 second.

Turning the ignition switch to "OFF" or "ACC" cancels the self-diagnosis function. If cancelled, repeat steps over again.

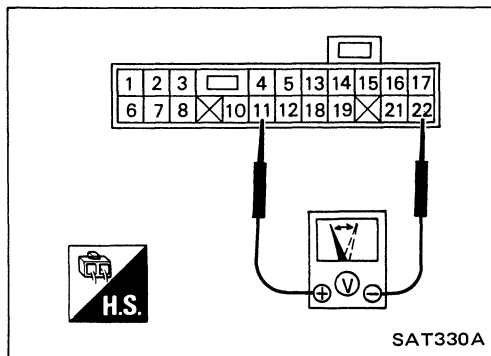

CHECK ㉕

- Turn ignition switch ON and move vehicle over 1 m (3 ft) at very low speed.

Voltage must vary from 0V to approx. 5V.

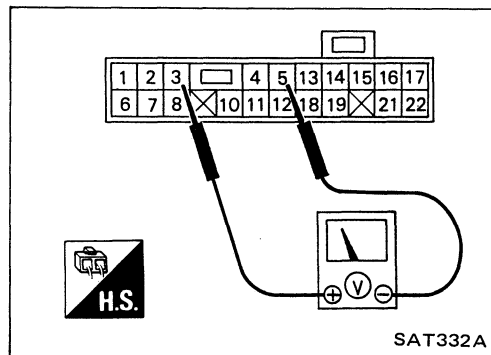

CHECK ㉖

[Throttle sensor power source]

- Turn ignition switch ON.
Approx. 5V at all times

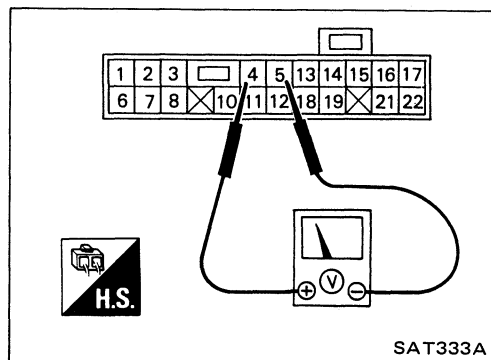

[Throttle sensor signal]

- Turn ignition switch ON.
Full-close throttle → Approx. 0.3V
Full-open throttle → Approx. 3V

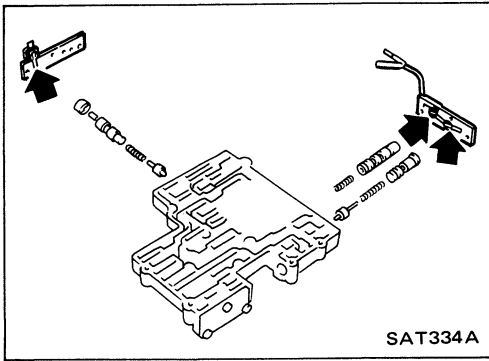

CHECK ⑧

- Check contact points of shift switches for damage.

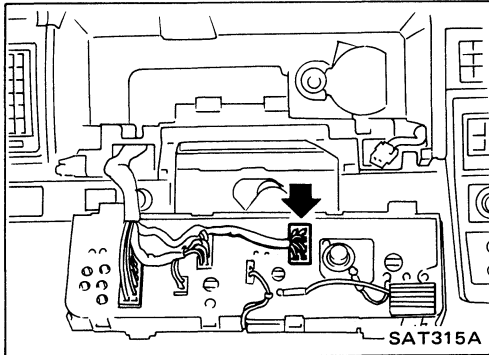

CHECK ⑨

- Check connection of vehicle speed sensor connector.
- Check wires between vehicle speed sensor and lock-up control unit.

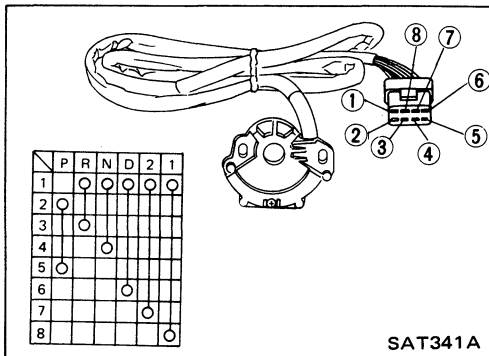

CHECK ⑩

- Check continuity between terminals.

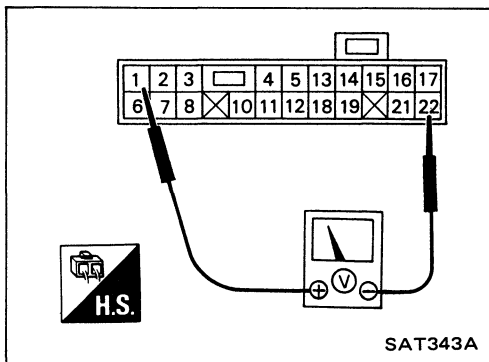

CHECK ⑪

- Measure voltage while driving vehicle.
 Accelerator pedal is fully depressed → 0V
 Accelerator pedal is released → Battery voltage

Customer Complaint (VG30i) : Shifting point is too high or too low

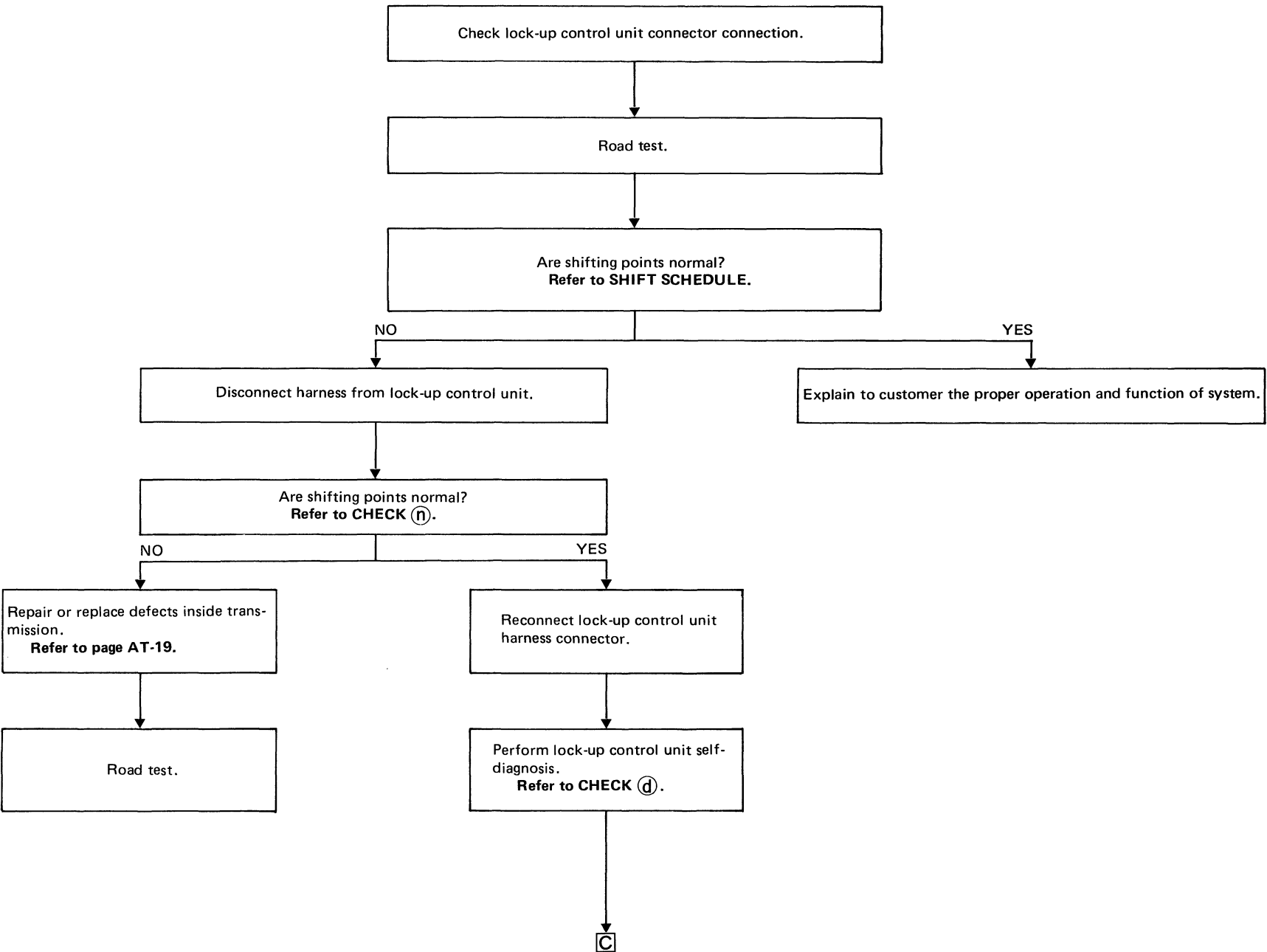

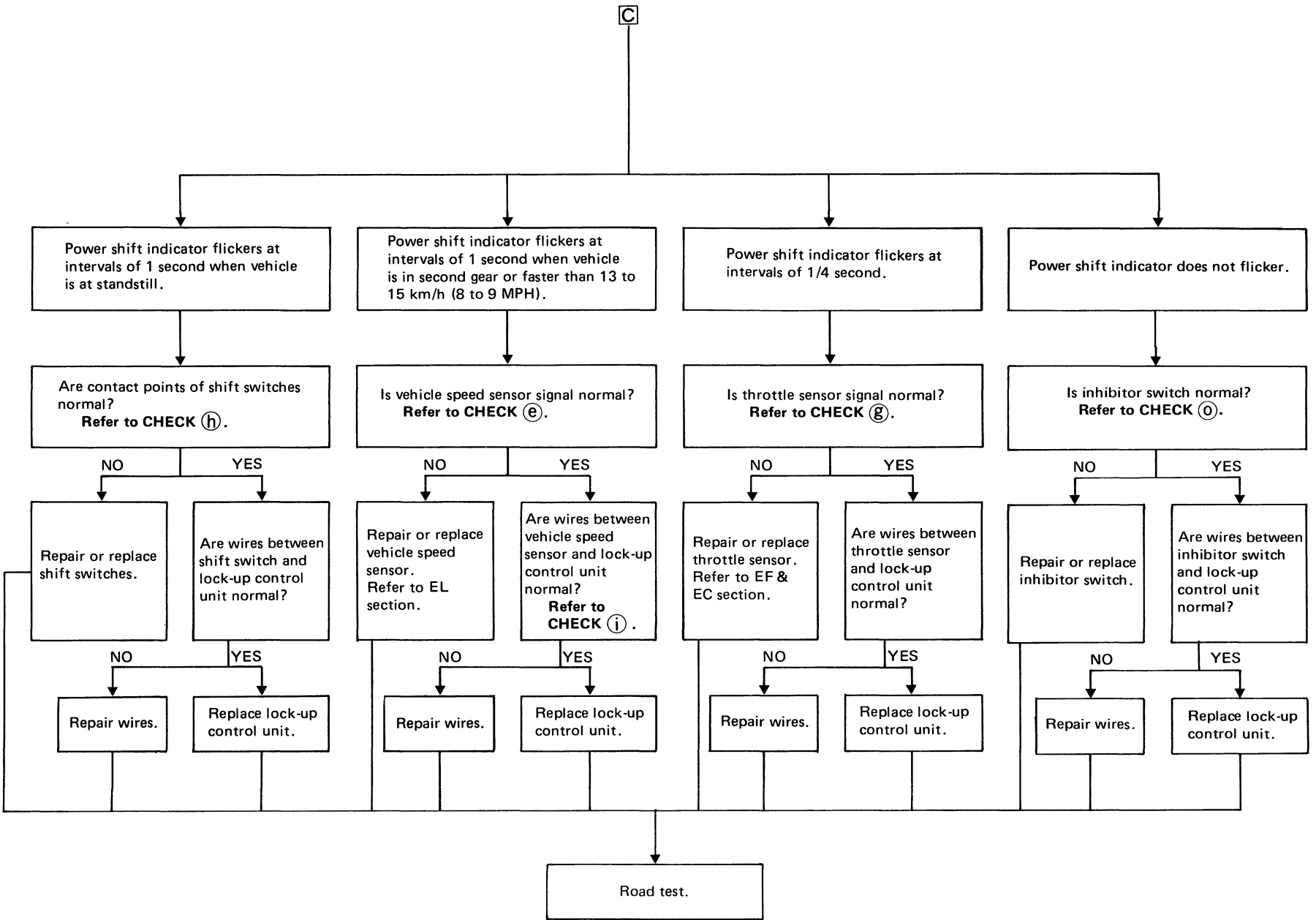

AT-55

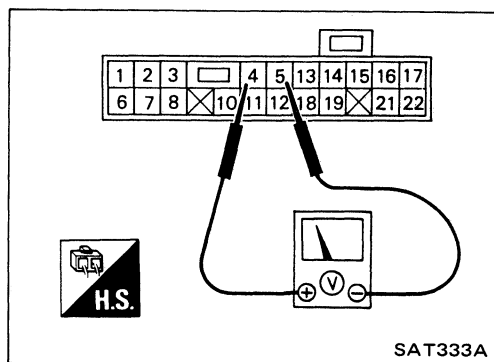
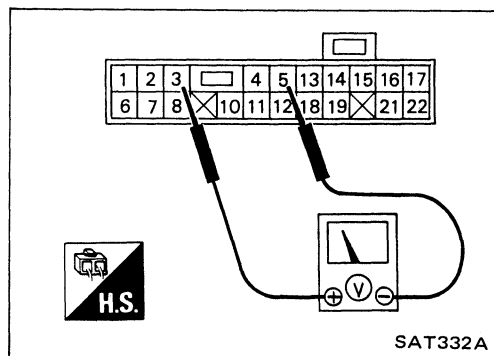
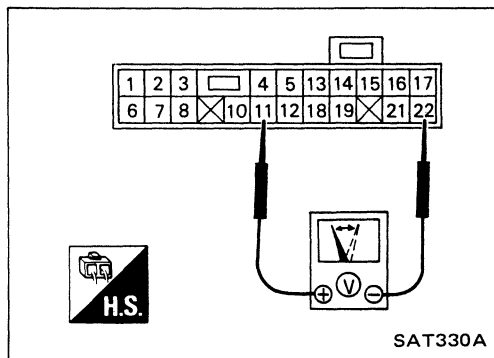
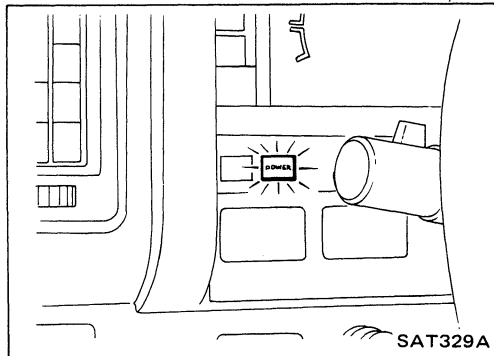
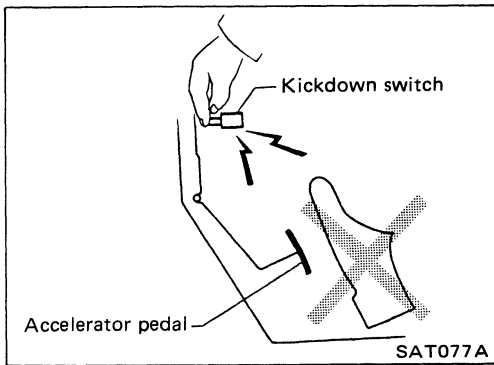

CHECK ㉔

Operate the self-diagnosis function as follows:

1. Turn power shift switch to "AUTO".
2. Turn the ignition switch to "ON".
Do not start the engine.
3. Operate kickdown switch by hand for at least one second.
Do not use accelerator pedal.

4. Start the engine and run the vehicle about 20 km/h (12 MPH), and check to see whether or not an abnormal condition exists.

When an abnormal condition exists, the power shift indicator lamp will flicker at intervals of 1 or 1/4 second.

Turning the ignition switch to "OFF" or "ACC" cancels the self-diagnosis function. If cancelled, repeat steps over again.

CHECK ㉕

- Turn ignition switch ON and move vehicle over 1 m (3 ft) at very low speed.

Voltage must vary from 0V to approx. 5V.

CHECK ㉖

[Throttle sensor power source]

- Turn ignition switch ON.
Approx. 5V at all times

[Throttle sensor signal]

- Turn ignition switch ON.
Full-close throttle → **Approx. 0.3V**
Full-open throttle → **Approx. 3V**

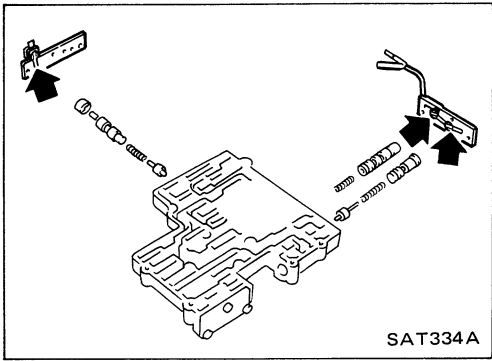

CHECK ㉞

- Check contact points of shift switches for damage.

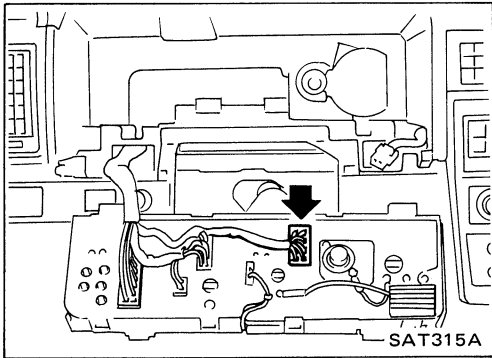

CHECK ㉟

- Check connection of vehicle speed sensor connector.
- Check wires between vehicle speed sensor and lock-up control unit.

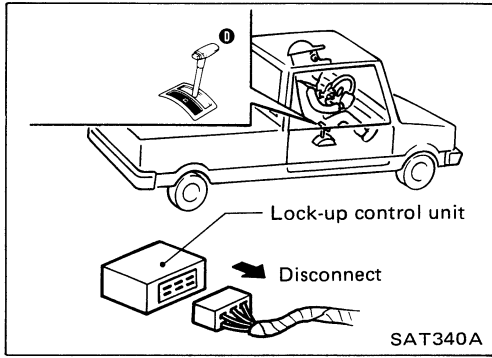

CHECK ㊱

Final gear ratio: 3.900

Throttle position	Gearshift	Vehicle speed km/h (MPH)
Full throttle	D ₁ → D ₂	56 - 64 (35 - 40)
	D ₂ → D ₃	103 - 111 (64 - 69)
	D ₃ → D ₄	—
	D ₄ → D ₃	—
	D ₃ → D ₂	94 - 102 (58 - 63)
	D ₂ → D ₁	44 - 51 (27 - 32)

Final gear ratio: 4.375

Throttle position	Gearshift	Vehicle speed km/h (MPH)
Full throttle	D ₁ → D ₂	50 - 57 (31 - 35)
	D ₂ → D ₃	93 - 100 (58 - 62)
	D ₃ → D ₄	—
	D ₄ → D ₃	—
	D ₃ → D ₂	84 - 91 (52 - 57)
	D ₂ → D ₁	39 - 46 (24 - 29)

CHECK ㊲

- Check continuity between terminals.

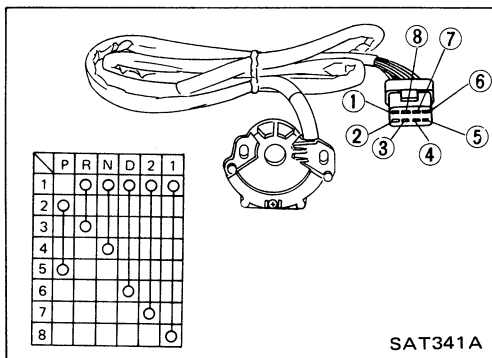

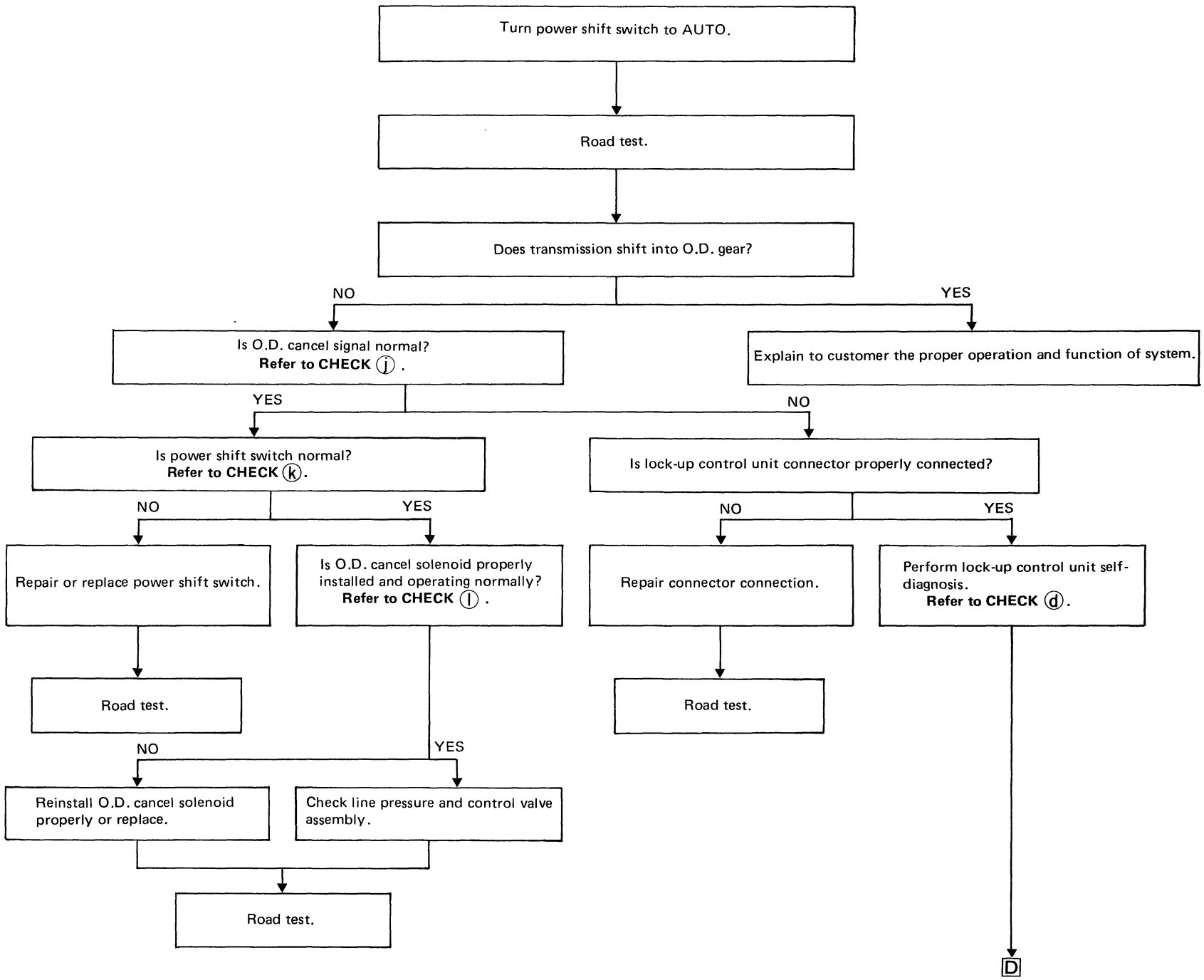

Customer Complaint (VG30i) :
Transmission does not shift into O.D. gear even if the power shift switch is turned to AUTO

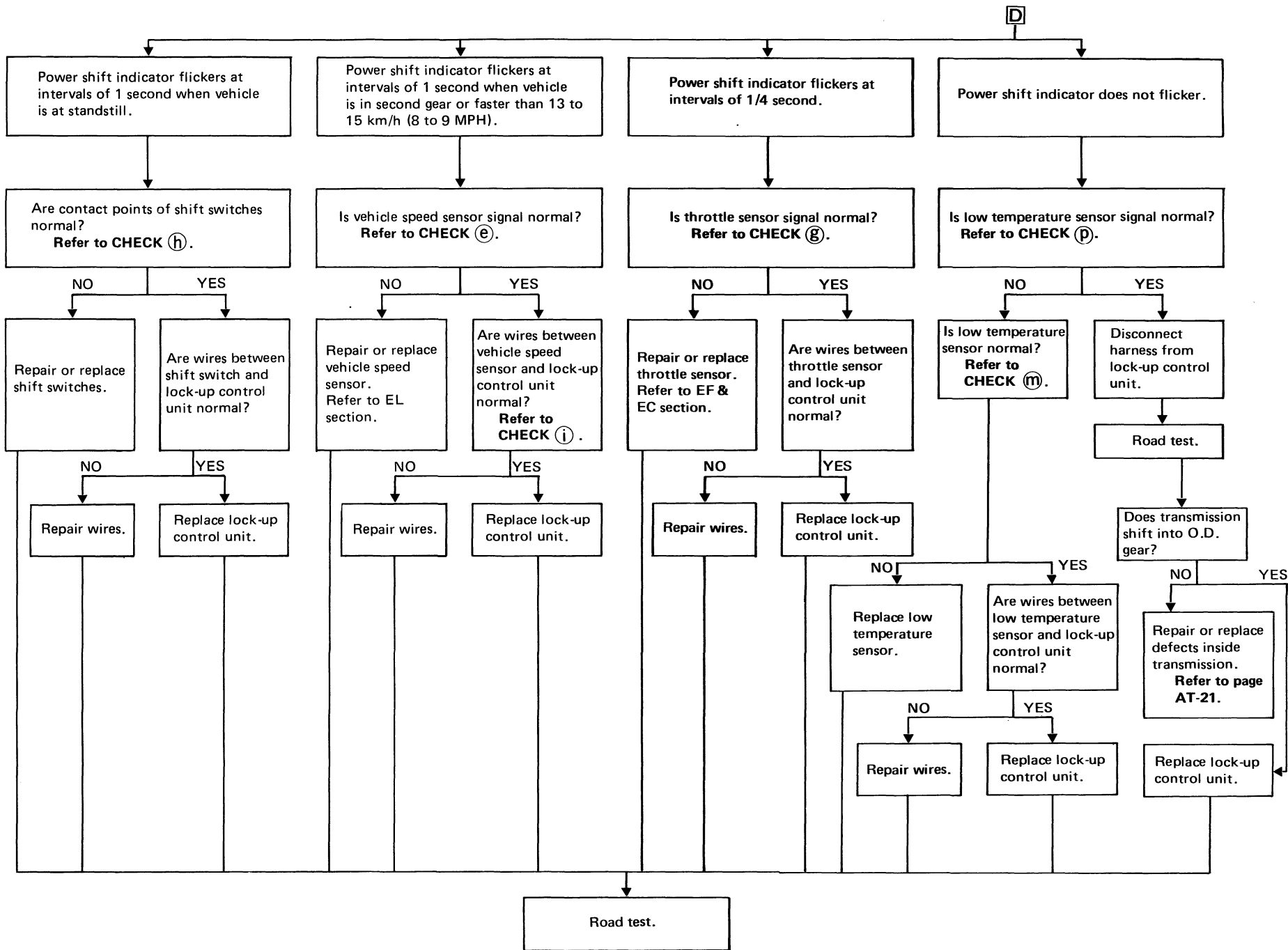

AT-59

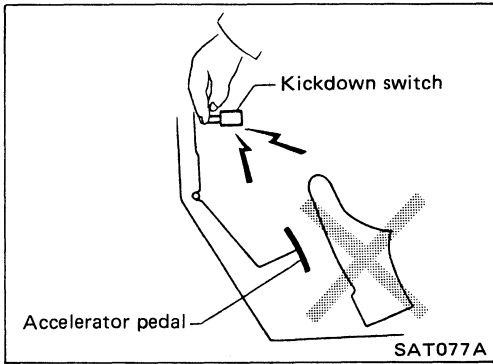

CHECK ㉔

Operate the self-diagnosis function as follows:

1. Turn power shift switch to "AUTO".
2. Turn the ignition switch to "ON".
Do not start the engine.
3. Operate kickdown switch by hand for at least one second.

Do not use accelerator pedal.

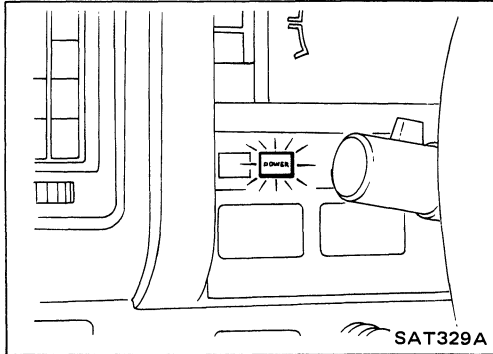

4. Start the engine and run the vehicle about 20 km/h (12 MPH), and check to see whether or not an abnormal condition exists.

When an abnormal condition exists, the power shift indicator lamp will flicker at intervals of 1 or 1/4 second.

Turning the ignition switch to "OFF" or "ACC" cancels the self-diagnosis function. If cancelled, repeat steps over again.

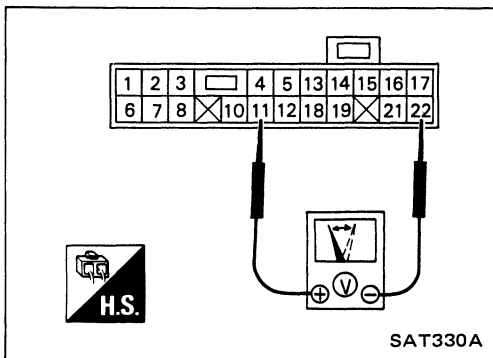

CHECK ㉕

- Turn ignition switch ON and move vehicle over 1 m (3 ft) at very low speed.

Voltage must vary from 0V to approx. 5V.

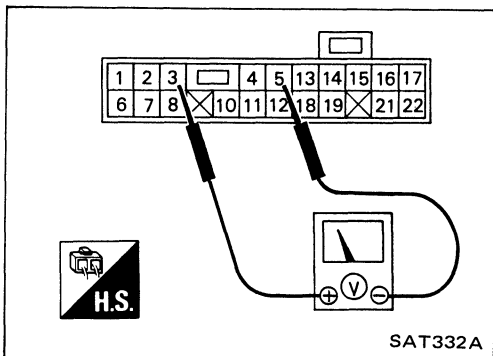

CHECK ㉖

[Throttle sensor power source]

- Turn ignition switch ON.
Approx. 5V at all times

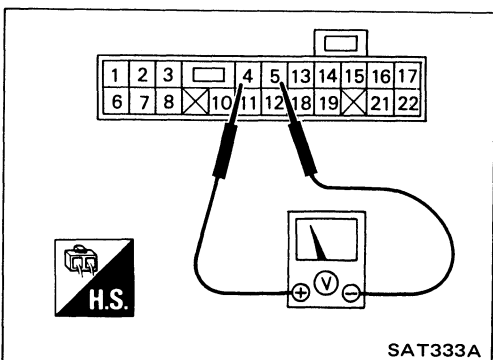

[Throttle sensor signal]

- Turn ignition switch ON.
Full-close throttle → **Approx. 0.3V**
Full-open throttle → **Approx. 3V**

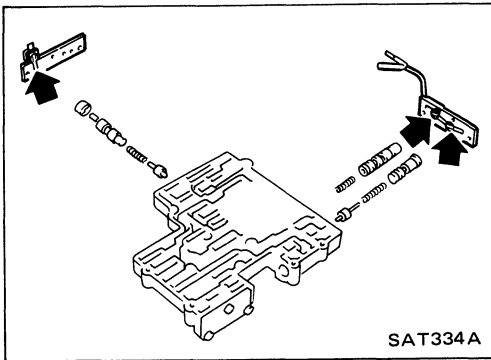

CHECK ⑧

- Check contact points of shift switches for damage.

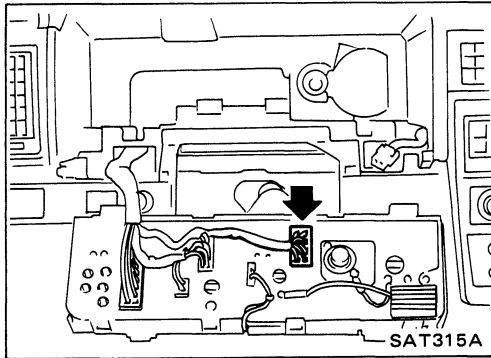

CHECK ⑨

- Check connection of vehicle speed sensor connector.
- Check wires between vehicle speed sensor and lock-up control unit.

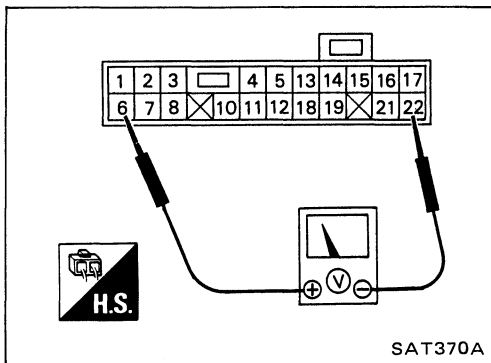

CHECK ⑩

- Turn power shift switch to "AUTO" and measure voltage while driving vehicle in "D" range.
60 km/h (37 MPH) or more with light load → Approx. 0V
Vehicle is at standstill → Battery voltage

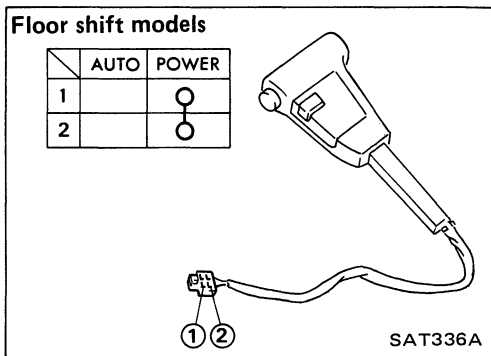

CHECK ⑪

- Check continuity between terminals.

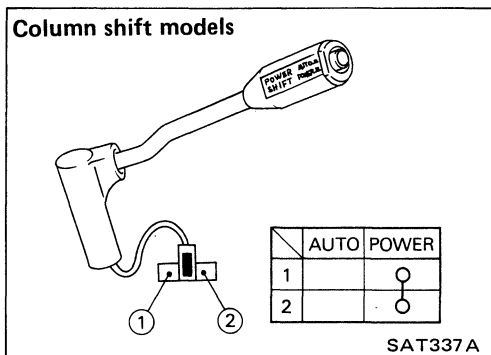

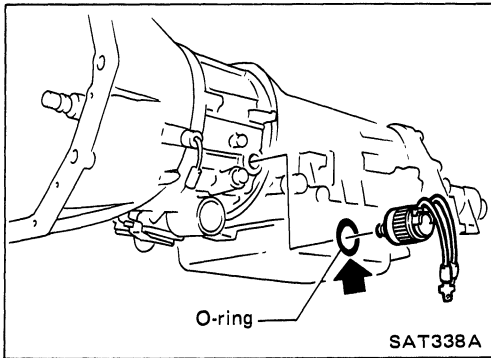

CHECK ①

- Check if O-ring is installed to tip of O.D. cancel solenoid.

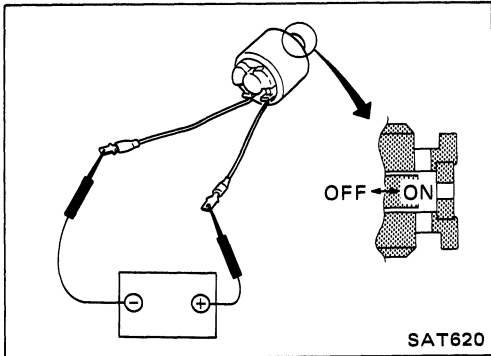

- Check operation of O.D. cancel solenoid by applying battery voltage.

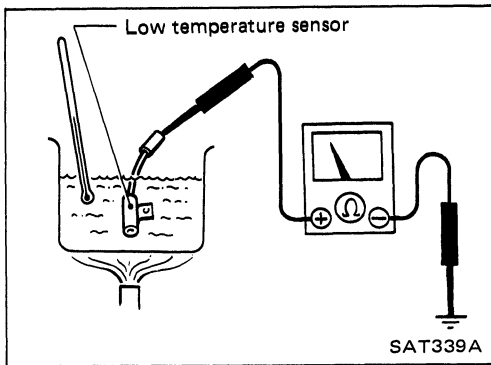

CHECK ③

- Check continuity on low temperature sensor.
 45°C (113°F) or higher $\rightarrow \infty$
 35°C (95°F) or lower $\rightarrow 0\Omega$

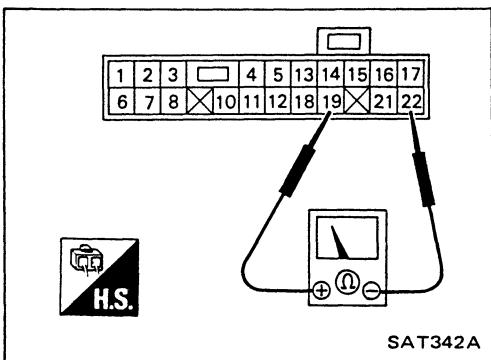

CHECK ④

- Turn ignition switch ON.
 A.T.F. temperature is 45°C (113°F) or higher $\rightarrow \infty$
 A.T.F. temperature is 35°C (95°F) or lower $\rightarrow 0\Omega$

Note:

Customer Complaint (VG30i) : Shift schedule will not turn to "power pattern" even if accelerator pedal is quickly depressed with power shift switch turned to AUTO during "D" range driving

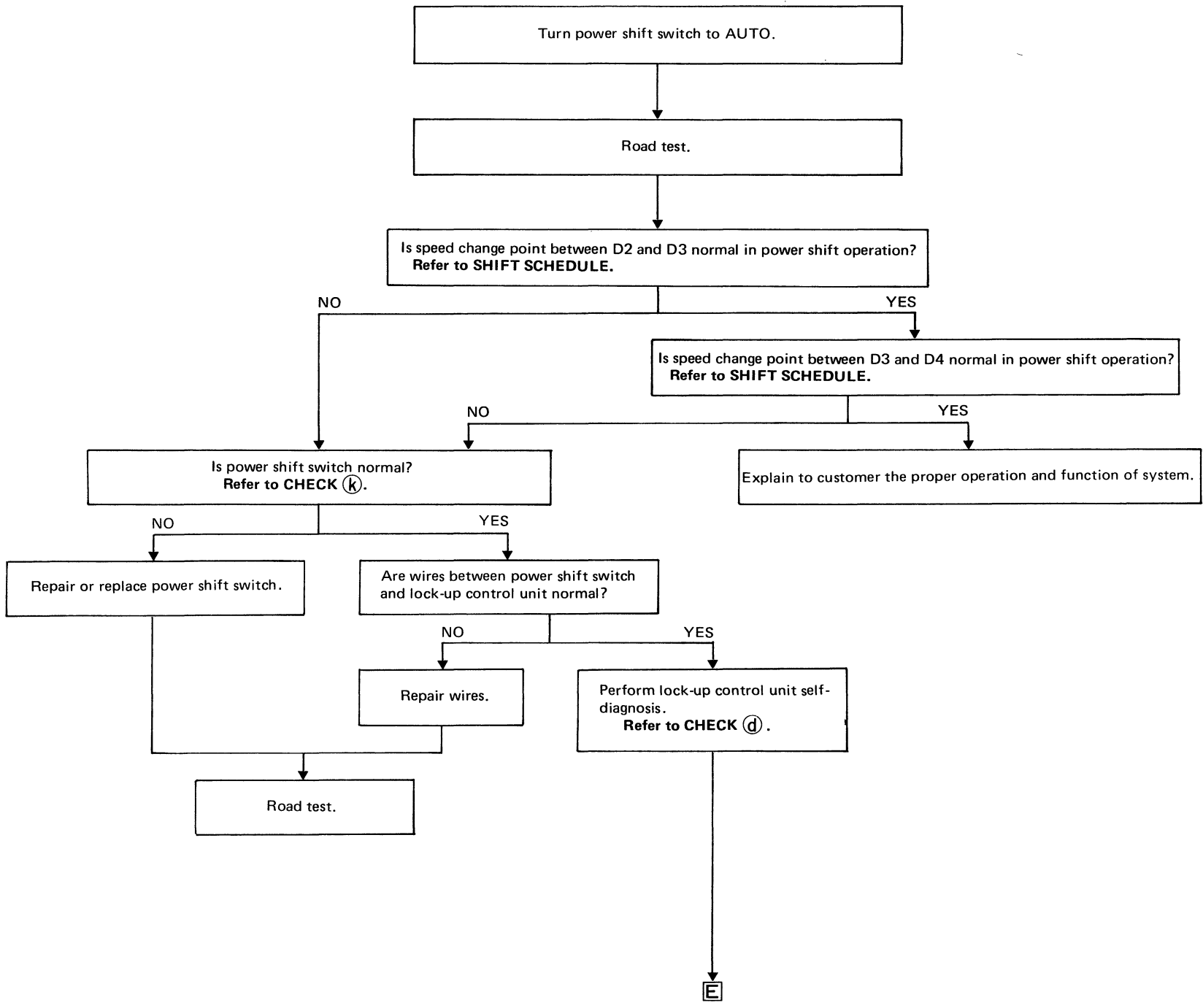

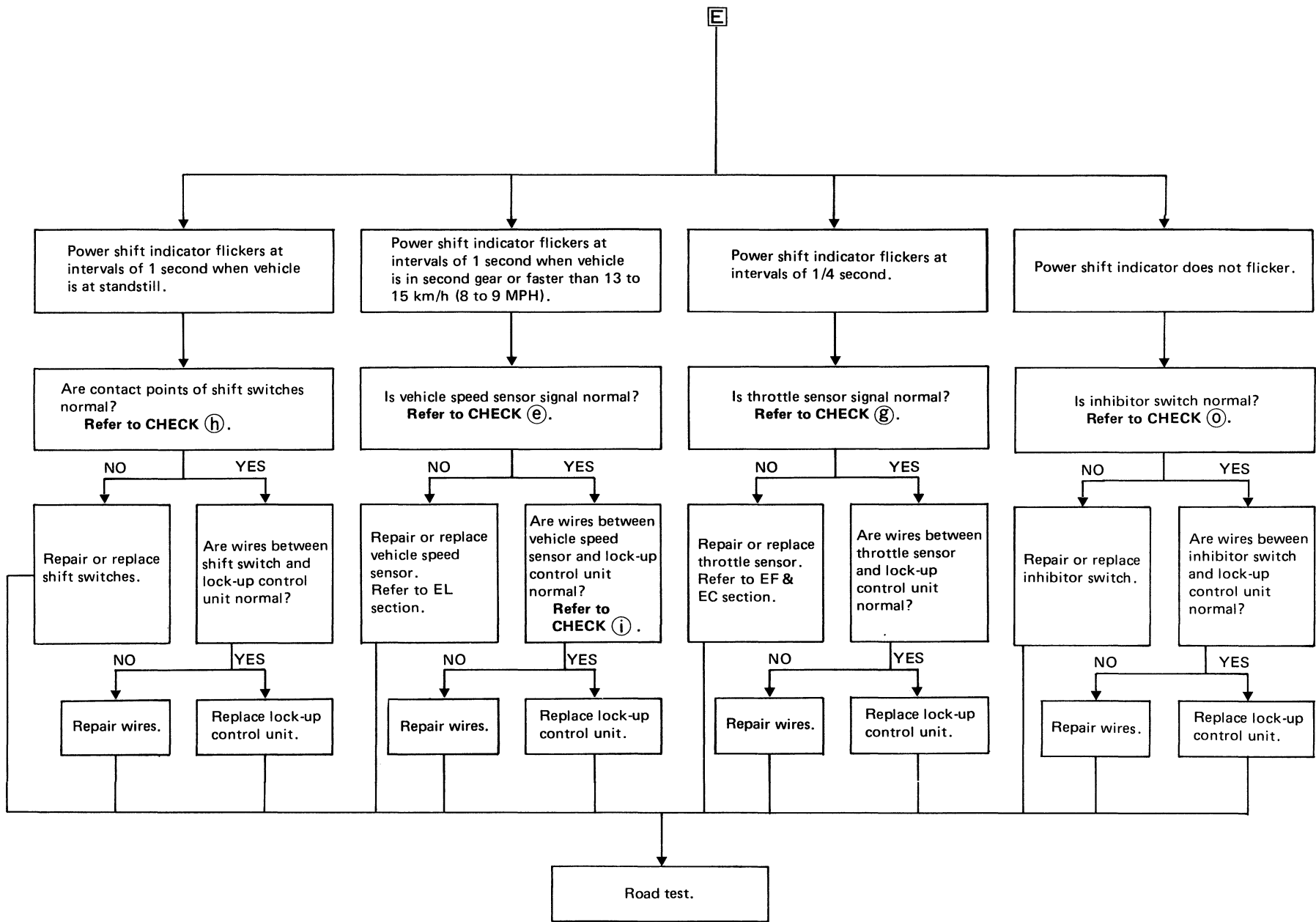

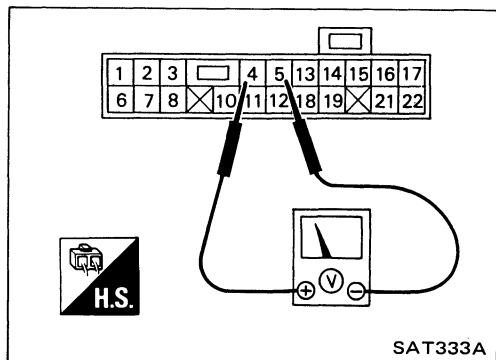
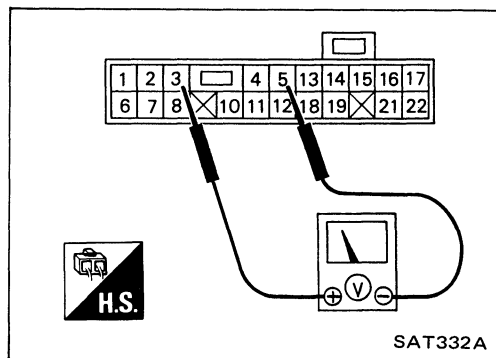
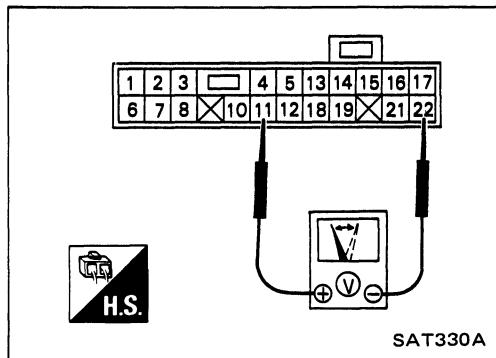
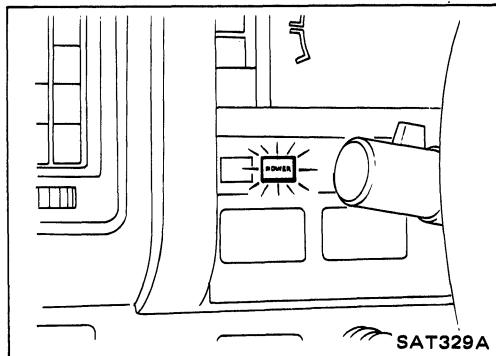
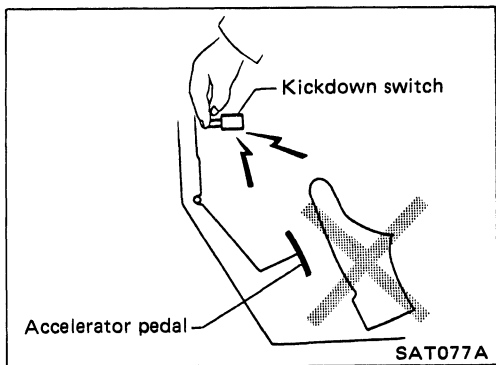

CHECK ㉔

Operate the self-diagnosis function as follows:

1. Turn power shift switch to "AUTO".
2. Turn the ignition switch to "ON".
Do not start the engine.
3. Operate kickdown switch by hand for at least one second.
Do not use accelerator pedal.

4. Start the engine and run the vehicle about 20 km/h (12 MPH), and check to see whether or not an abnormal condition exists.
When an abnormal condition exists, the power shift indicator lamp will flicker at intervals of 1 or 1/4 second.
Turning the ignition switch to "OFF" or "ACC" cancels the self-diagnosis function. If cancelled, repeat steps over again.

CHECK ㉕

- Turn ignition switch ON and move vehicle over 1 m (3 ft) at very low speed.
Voltage must vary from 0V to approx. 5V.

CHECK ㉖

[Throttle sensor power source]

- Turn ignition switch ON.
Approx. 5V at all times

[Throttle sensor signal]

- Turn ignition switch ON.
Full-close throttle → **Approx. 0.3V**
Full-open throttle → **Approx. 3V**

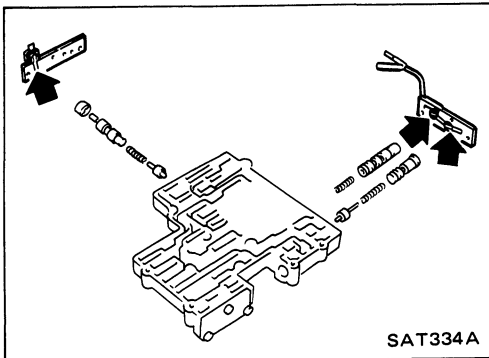

CHECK ⑧

- Check contact points of shift switches for damage.

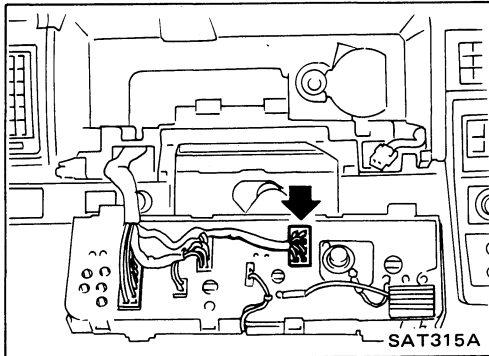

CHECK ⑨

- Check connection of vehicle speed sensor connector.
- Check wires between vehicle speed sensor and lock-up control unit.

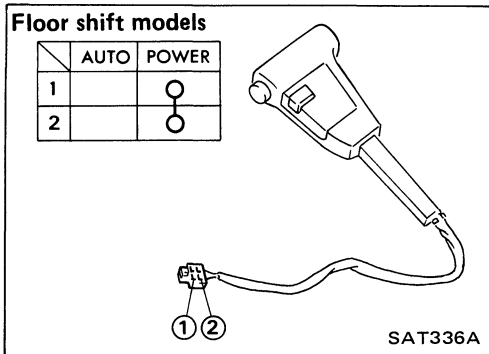

CHECK ⑩

- Check continuity between terminals.

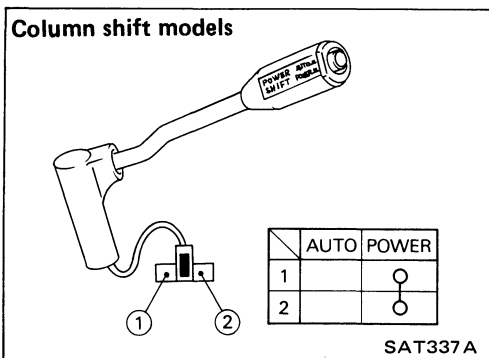

CHECK ⑪

- Check continuity between terminals.

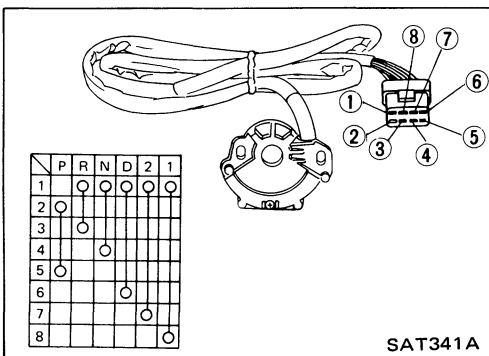

**Customer Complaint (VG30i) :
Transmission does not kickdown**

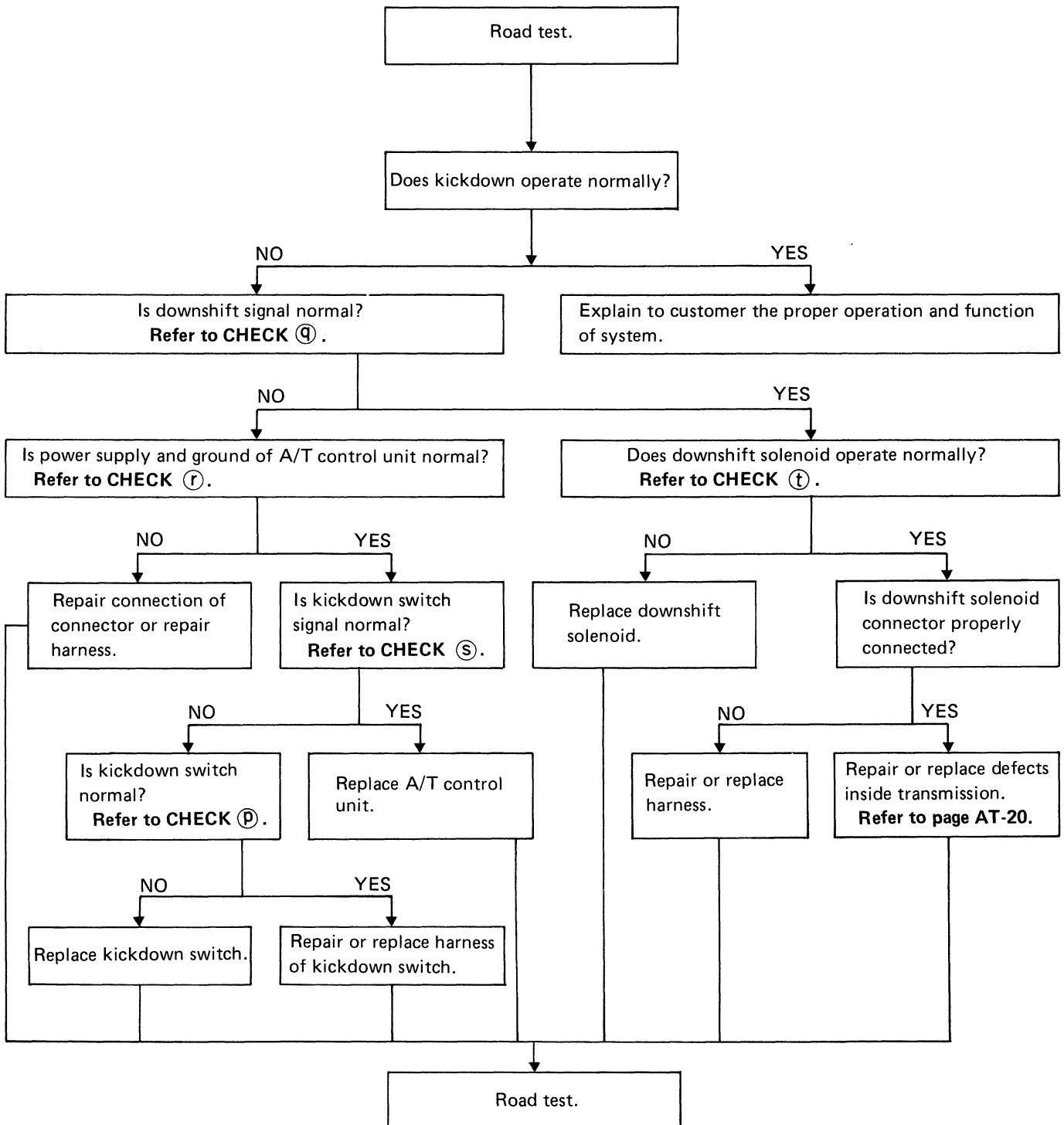

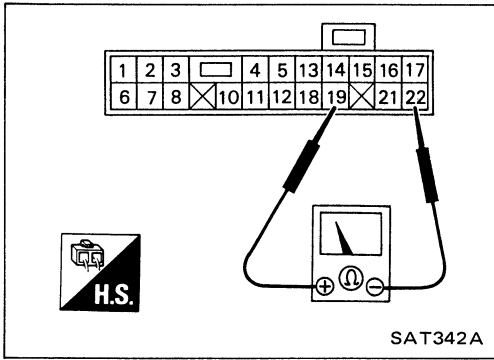

CHECK ⑨

- Turn ignition switch ON.
 A.T.F. temperature is 45°C (113°F) or higher → ∞
 A.T.F. temperature is 35°C (95°F) or lower → 0Ω

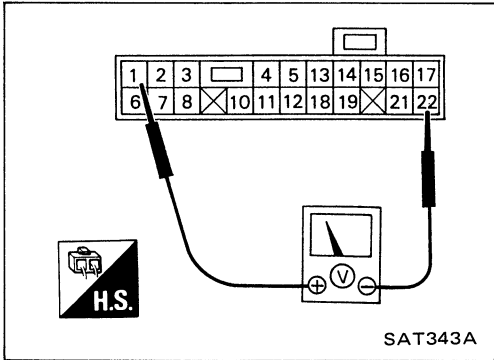

CHECK ⑩

- Measure voltage while driving vehicle.
 Accelerator pedal is fully depressed → 0V
 Accelerator pedal is released → Battery voltage

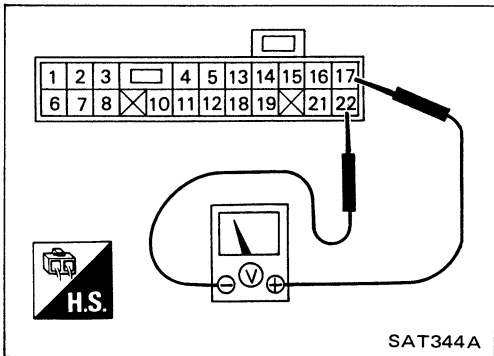

CHECK ⑪

- Turn ignition switch ON.
 Battery voltage at all times

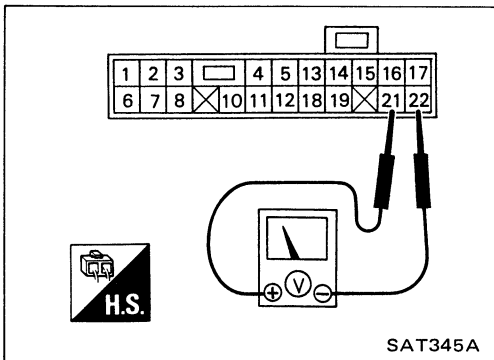

CHECK ⑫

- Turn ignition switch ON.
 Accelerator pedal is fully depressed → Approx. 0V
 Accelerator pedal is released → Approx. 5V

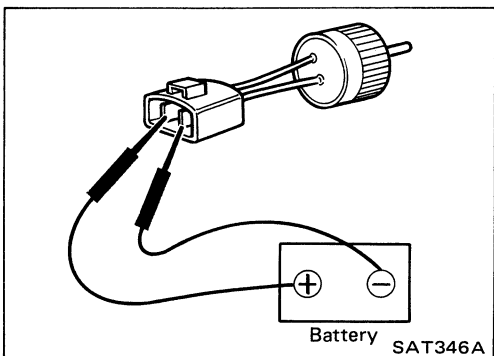

CHECK ⑬

- Check operation of downshift solenoid by applying battery voltage.

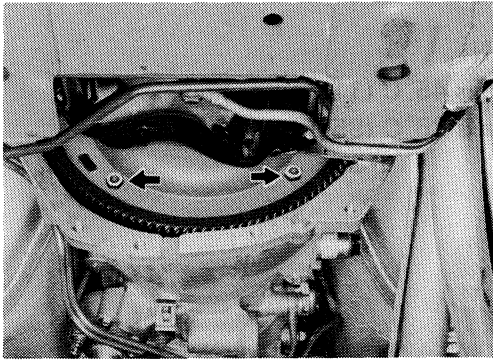

Removal

- Remove exhaust front tube (VG30i engine model).
- Plug up openings such as oil charging pipe, etc.
- Remove bolts securing torque converter to drive plate.
 - a. Remove those bolts by turning crankshaft.
 - b. Right after the transmission was disconnected, inscribe matching marks on torque converter and drive plate so that they can be assembled in their original positions.

CAUTION:

Take care not to strike any adjacent parts during dismantling.

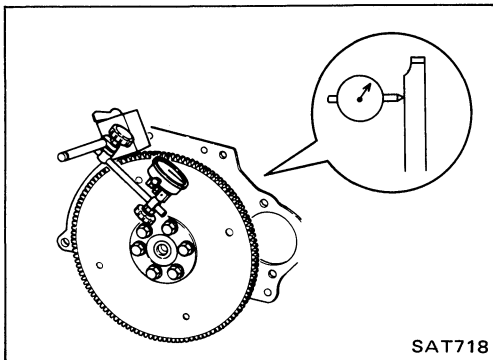

SAT718

Installation

- Drive plate runout
 - Maximum allowable runout:
0.5 mm (0.020 in)

If this runout is out of allowance, replace drive plate with ring gear.
- When connecting torque converter to transmission, measure distance "A" to be certain that they are correctly assembled.
 - Distance "A":
35 mm (1.38 in) or more

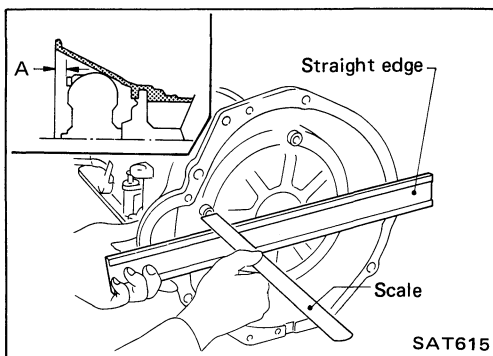

SAT615

- Install converter to drive plate.

Align matching marks inscribed on both parts during disassembly.
- After converter is installed, rotate crankshaft several turns and check to be sure that transmission rotates freely without binding.

Installation (Cont'd)

- Check inhibitor switch for operation.
- Check fluid level in transmission.
- Move selector lever through all positions to be sure that transmission operates correctly.

With parking brake applied, rotate engine at idling. Move selector lever through "N" to "D", to "2", to "1" and to "R". A slight shock should be felt by hand gripping selector each time transmission is shifted.

- Check to be sure that line pressure is correct. To do this, refer to Line Pressure Test.
- Perform stall test.

Note:

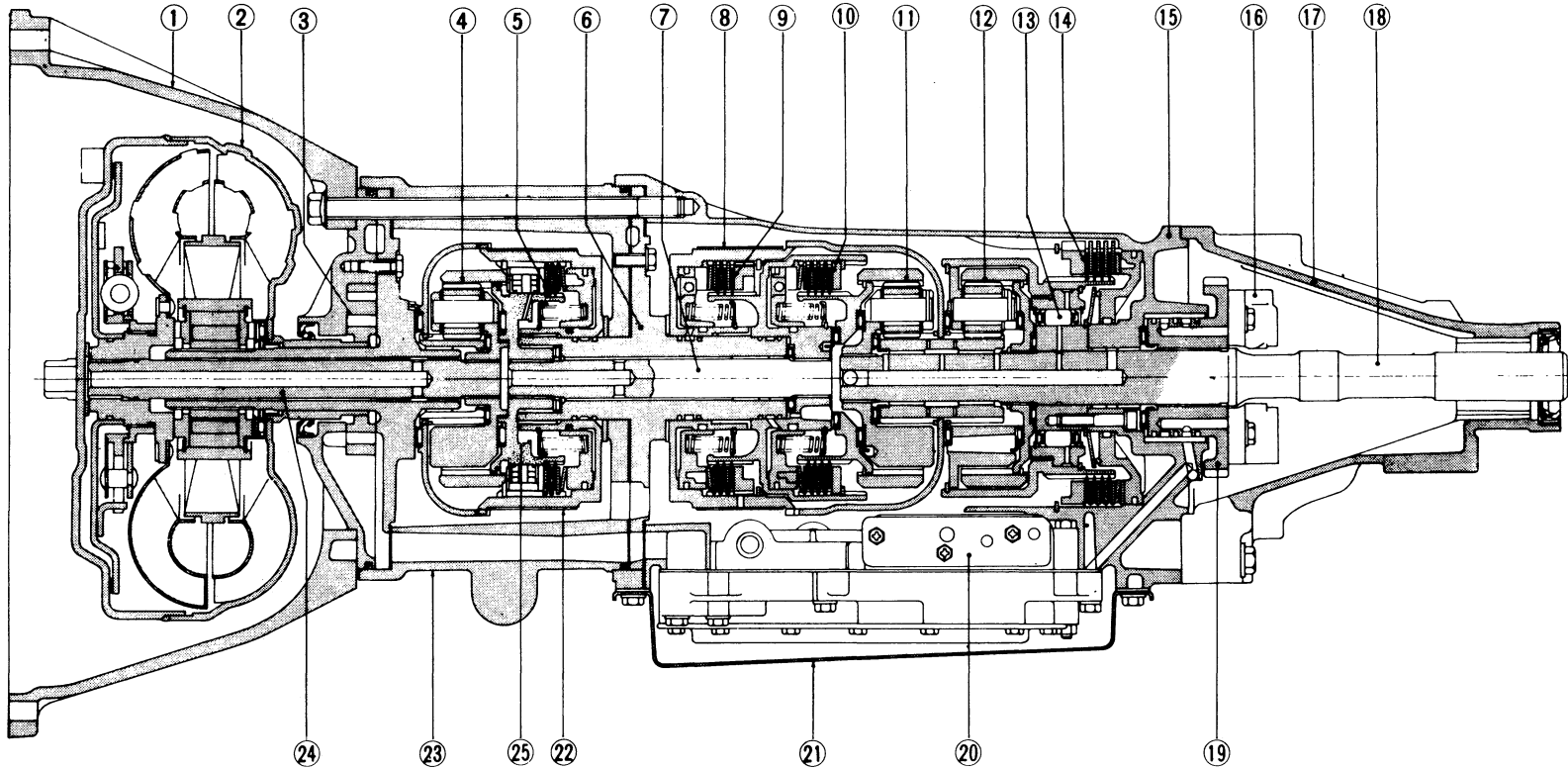

- 1 Converter housing
- 2 Torque converter
- 3 Oil pump assembly
- 4 O.D. planetary gear
- 5 Direct clutch
- 6 Drum support

- 7 Intermediate shaft
- 8 2nd band brake
- 9 Front clutch
- 10 Rear clutch
- 11 Front planetary gear
- 12 Rear planetary gear

- 13 One-way clutch
- 14 Low & reverse clutch
- 15 Transmission case
- 16 Governor valve assembly
- 17 Rear extension
- 18 Output shaft

- 19 Oil distributor
- 20 Control valve assembly
- 21 Oil pan
- 22 O.D. band brake
- 23 O.D. case
- 24 Input shaft
- 25 O.D. one-way clutch

L4N71B and E4N71B

Ⓢ : N·m (kg·m, ft·lb)

- Ⓐ 39 - 49 (4.0 - 5.0, 29 - 36)
- Ⓑ 10 - 15 (1.0 - 1.5, 7 - 11)
- Ⓒ 44 - 54 (4.5 - 5.5, 33 - 40)
- Ⓓ 13 - 18 (1.3 - 1.8, 9 - 13)
- Ⓔ 5 - 7 (0.5 - 0.7, 3.6 - 5.1)
- Ⓕ 8 - 11 (0.8 - 1.1, 5.8 - 8.0)
- Ⓖ 7 - 9 (0.7 - 0.9, 5.1 - 6.5)
- Ⓗ 5.4 - 7.4 (0.55 - 0.75, 4.0 - 5.4)
- Ⓙ 5 - 7 (0.5 - 0.7, 3.6 - 5.1)
- Ⓚ 29 - 39 (3.0 - 4.0, 22 - 29)

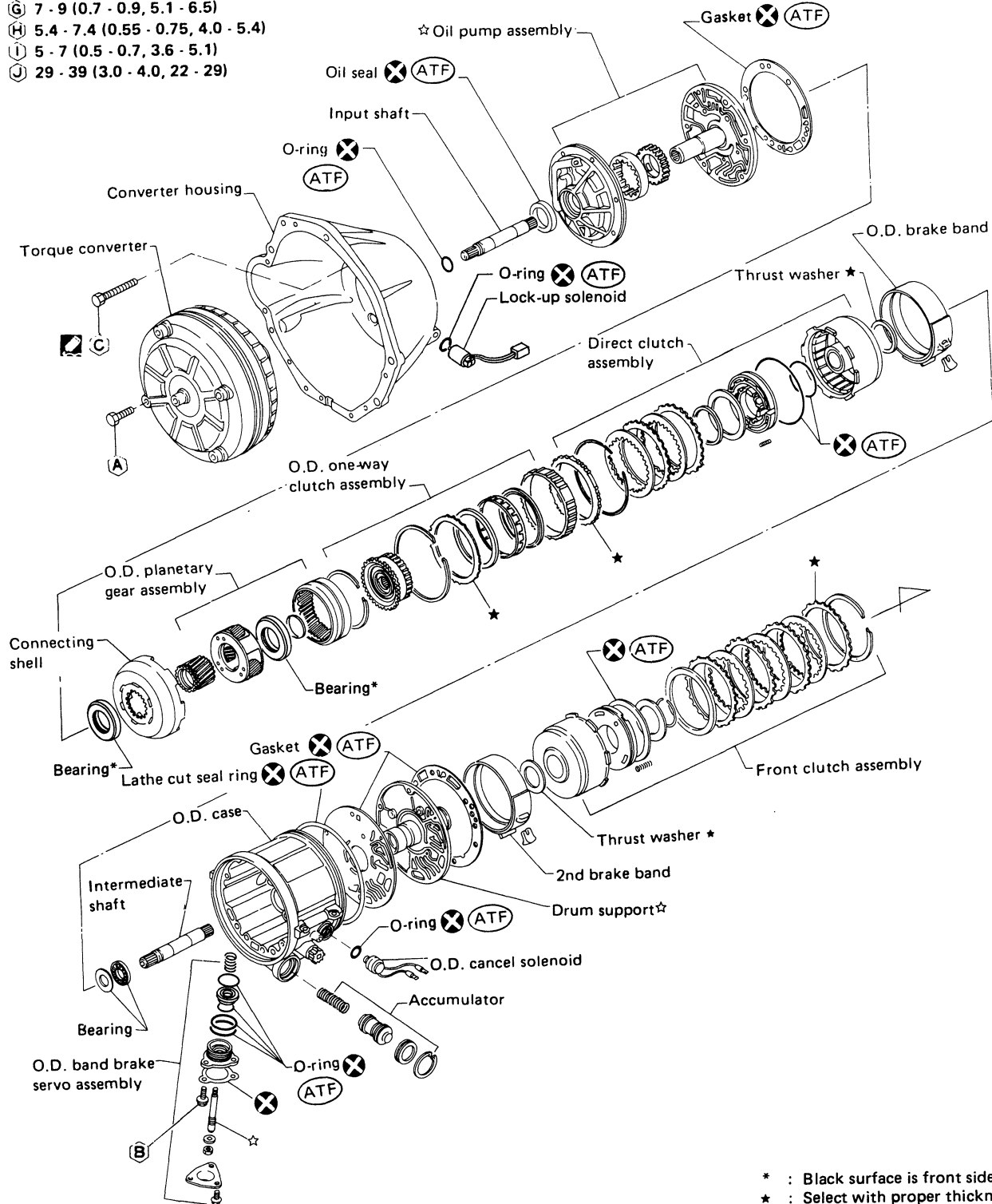

* : Black surface is front side.
 ★ : Select with proper thickness.
 ☆ : Adjustment is required.

Ⓢ : Apply A.T.F.

L4N71B and E4N71B (Cont'd)

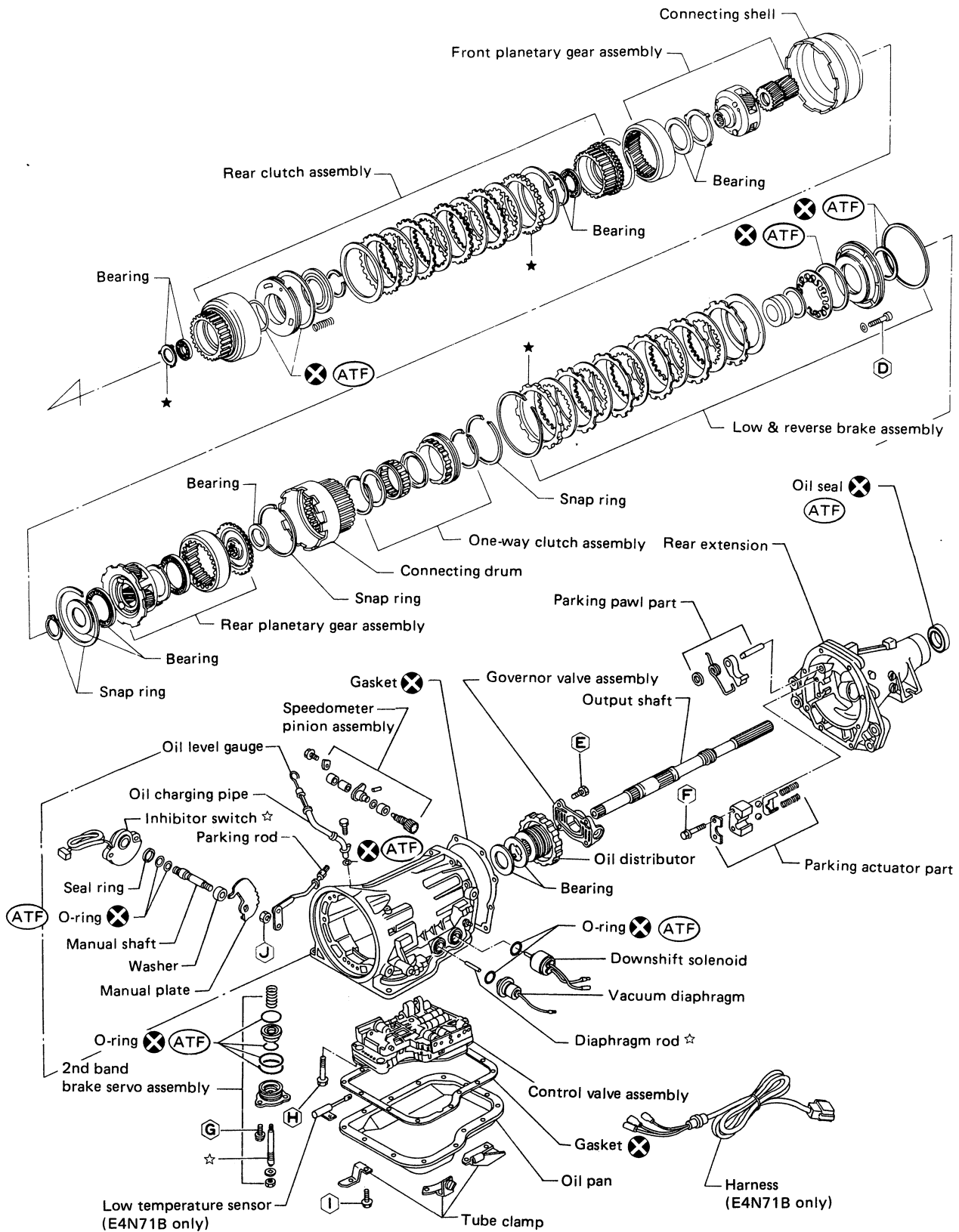

Hydraulic Control Circuits (L4N71B and E4N71B)

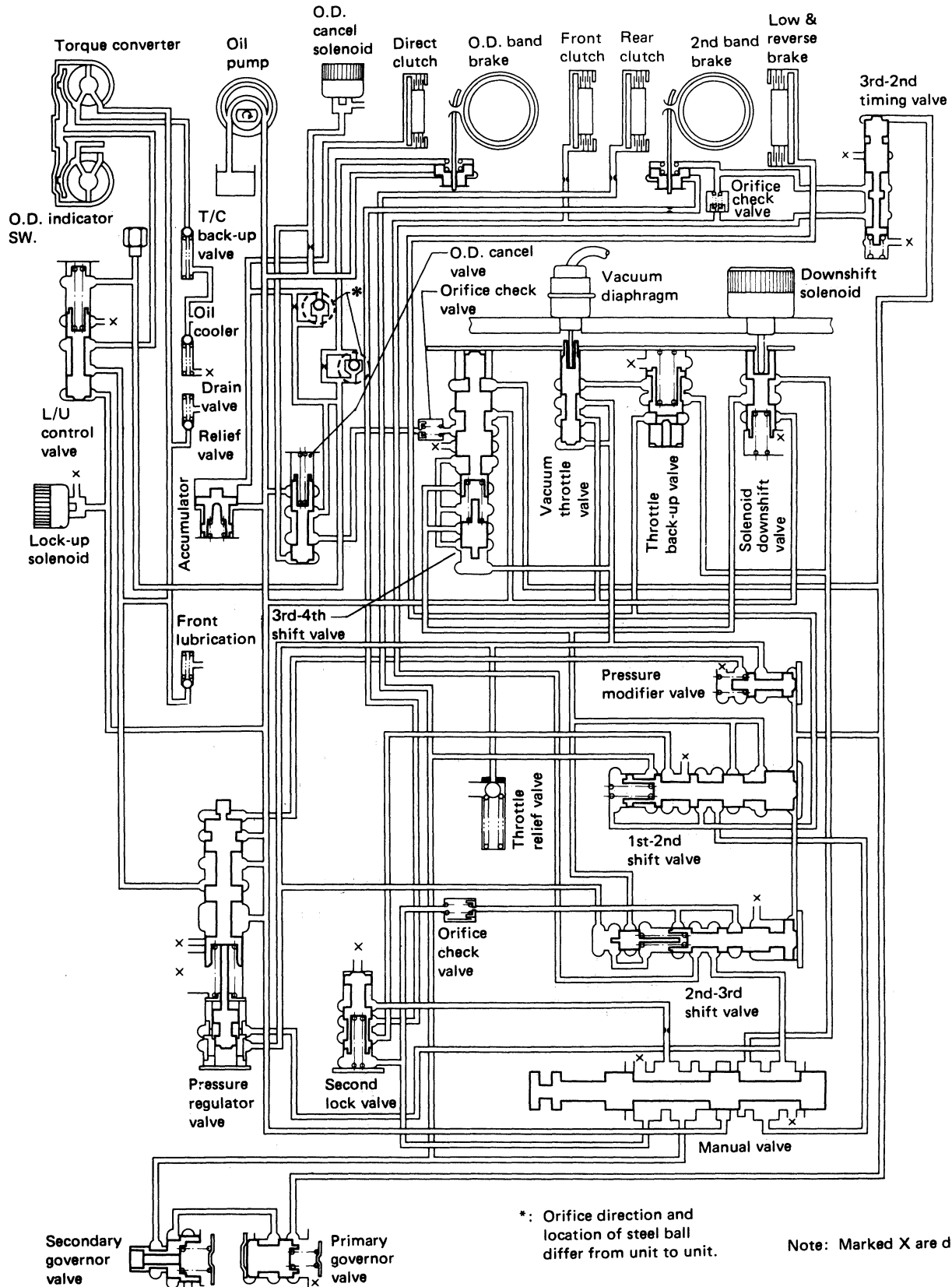

Mechanical Operation

Range	Direct clutch	O.D. band servo		Front clutch	Rear clutch	Low & reverse brake	2nd band servo		One-way clutch	Parking pawl
		Apply	Release				Apply	Release		
Park	ON	(ON)	ON			ON				ON
Reverse	ON	(ON)	ON	ON		ON		ON		
Neutral	ON	(ON)	ON							
D	D ₁ (Low)	ON	(ON)	ON					ON	
	D ₂ (Second)	ON	(ON)	ON			ON			
	D ₃ (Top)	ON	(ON)	ON	ON	ON		(ON)	ON	
	D ₄ (O.D.)		ON		ON	ON		(ON)	ON	
2	Second	ON	(ON)	ON			ON			
1	1 ₂ (Second)	ON	(ON)	ON			ON			
	1 ₁ (Low)	ON	(ON)	ON		ON			ON	

The low & reverse brake is applied in "1₁" range to prevent free wheeling when coasting and allows engine braking.

Oil Channel

Oil pump

Cover side

Housing side

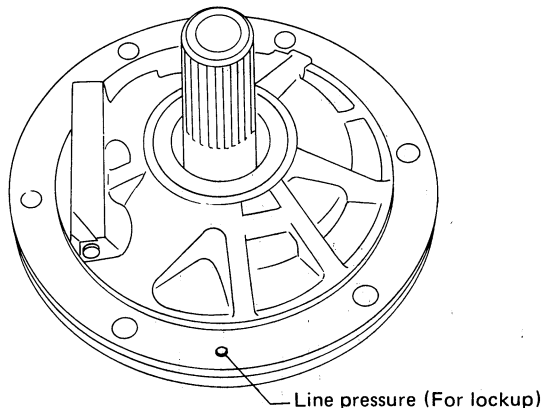
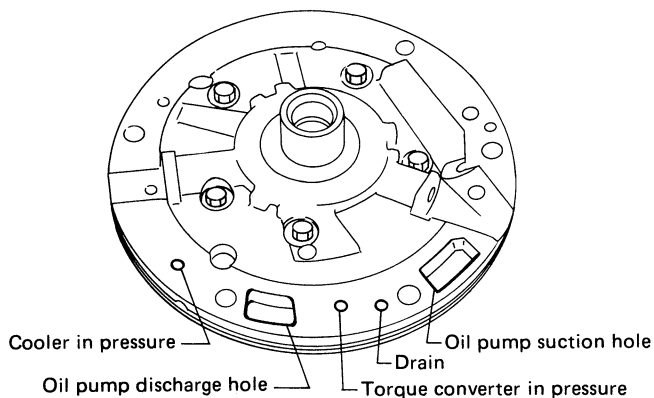

Oil Channel (Cont'd)

Transmission case

Front face side

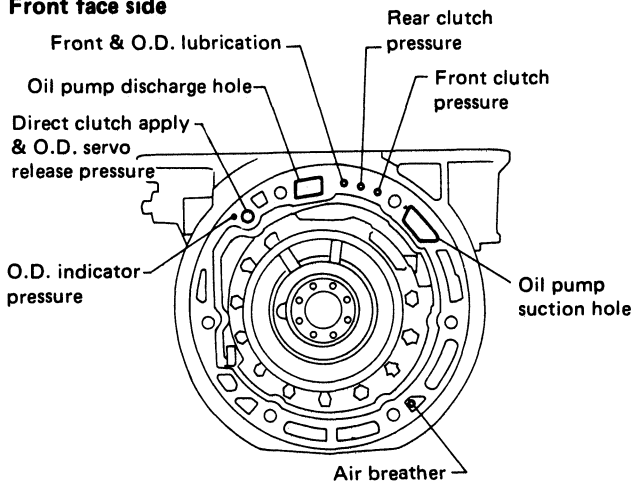

Lower face side

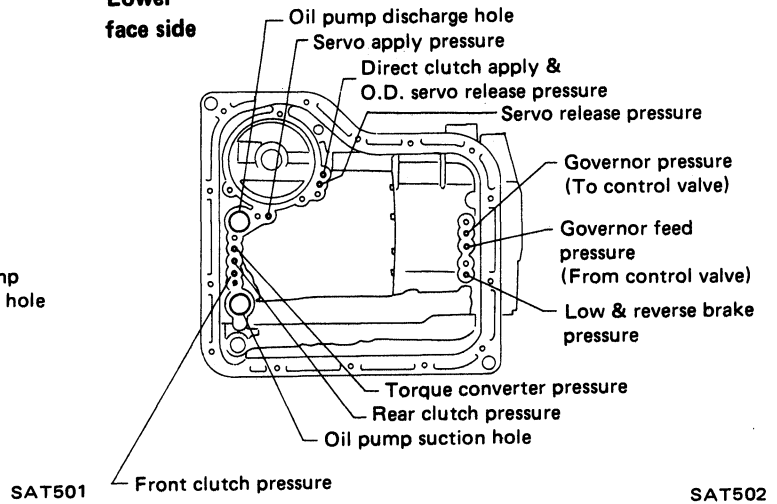

SAT502

O.D. case

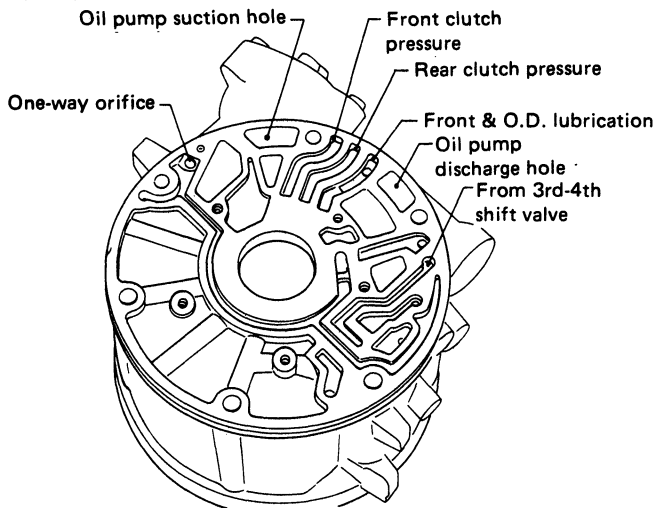

In regards to one-way orifice, refer to page AT-90.

SAT645

Drum support

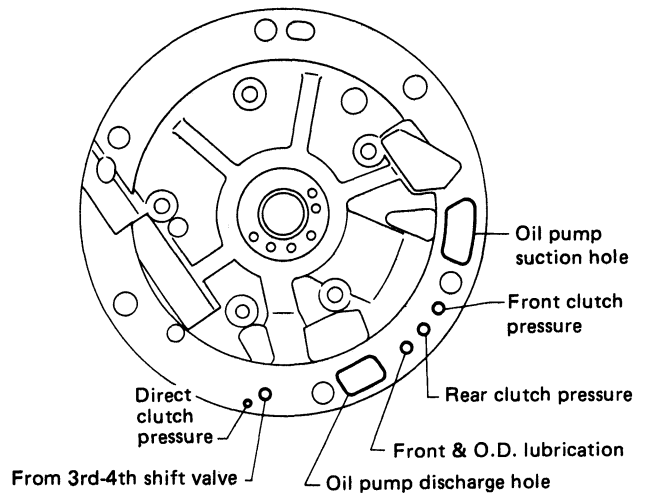

SAT503

Converter housing

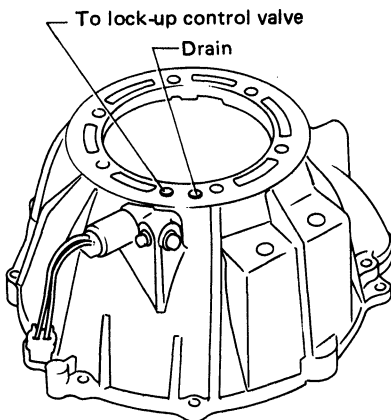

SAT706

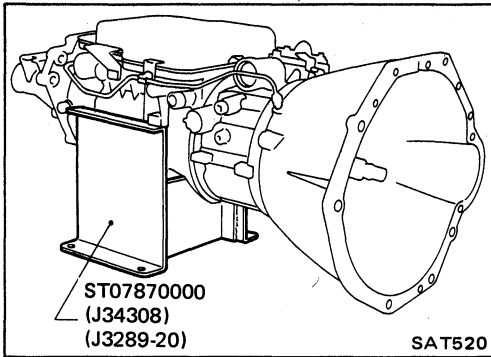

1. Remove torque converter, drain A.T.F. through end of rear extension, and place transmission on Tool.

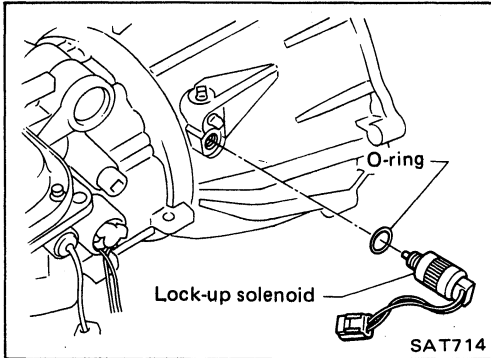

2. Remove lock-up solenoid.

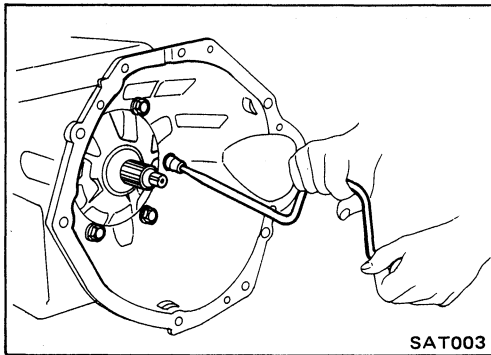

3. Remove converter housing.

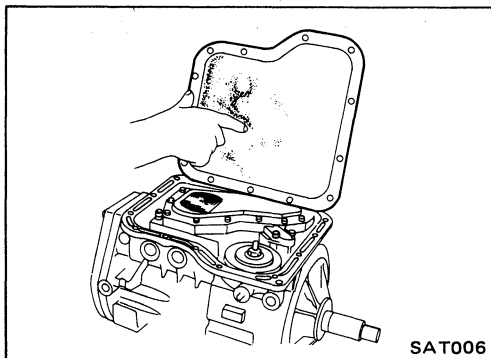

4. Remove oil pan and inspect its contents. An analysis of any foreign matter can indicate the types of problems to look for. If the fluid is very dark, smells burned, or contains foreign particles, the frictional material (clutches, band,) may need replacement. A tacky film that will not wipe clean indicates varnish build up which can cause valves, servo, and clutches to stick and may inhibit pump pressure.

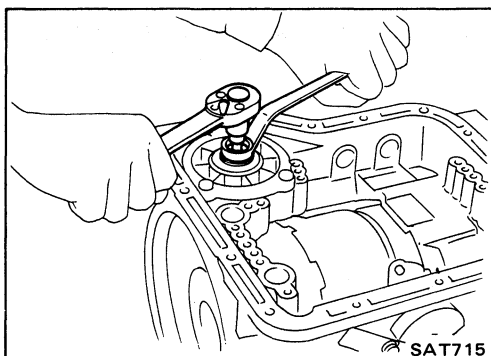

5. Loosen 2nd band servo piston stem lock nut and tighten piston stem.

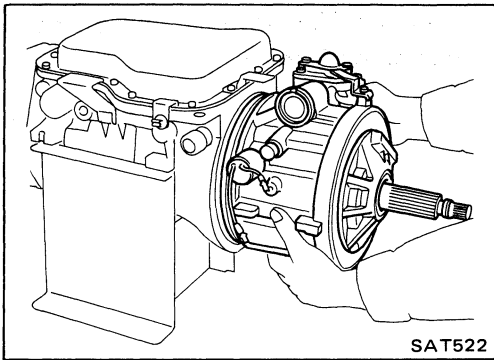

- Remove O.D. component assembly, then remove front clutch thrust washer and needle bearing & race.

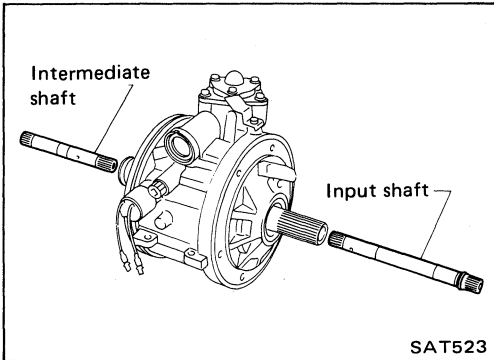

- Draw out input shaft and intermediate shaft.

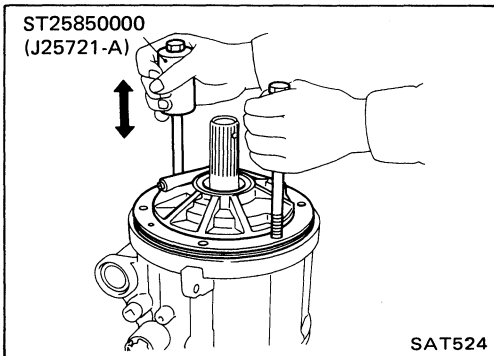

- Attach Tool to pump and remove pump.

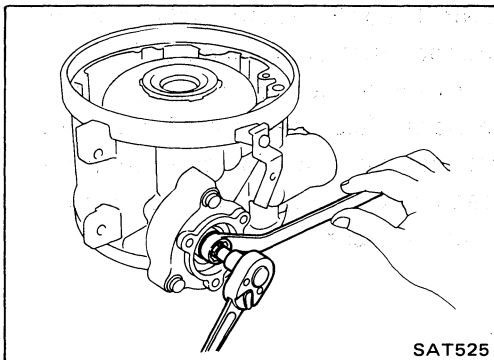

- Remove O.D. servo cover, then loosen O.D. band servo piston stem.

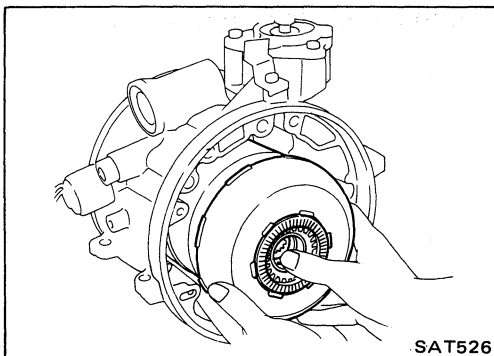

- Remove O.D. pack (O.D. planetary gear & direct clutch assembly).

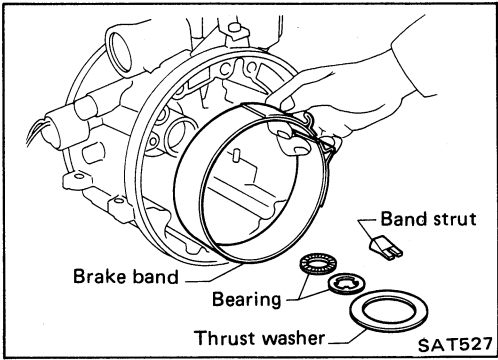

11. Remove needle bearing & race and direct clutch thrust washer, then remove O.D. brake band & strut.

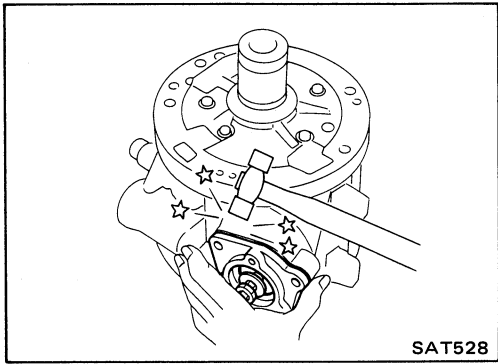

12. Remove O.D. servo assembly by lightly tapping retainer.

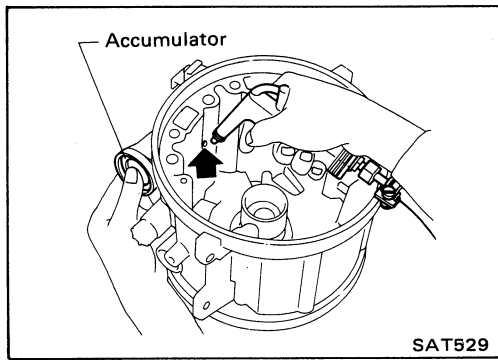

13. Remove accumulator snap ring, then apply pressure to remove accumulator plug, piston and spring.

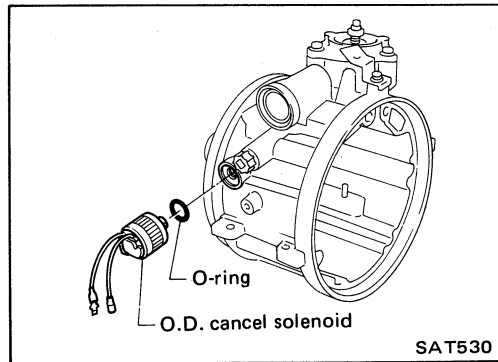

14. Remove O.D. cancel solenoid and O-ring.

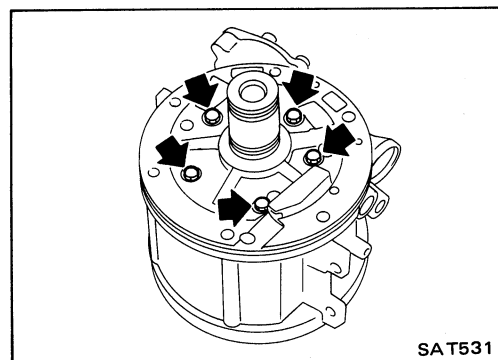

15. Remove drum support.

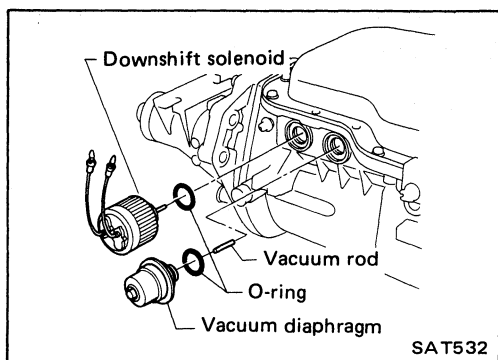

16. Remove downshift solenoid, vacuum diaphragm & rod and O-rings.

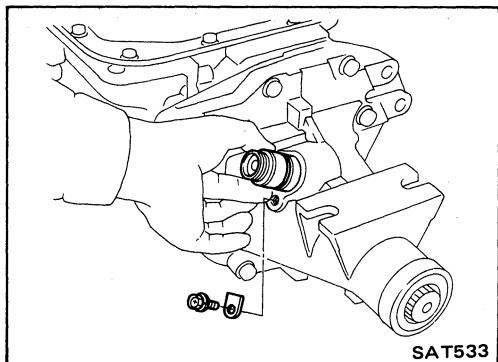

17. Remove speedometer pinion.

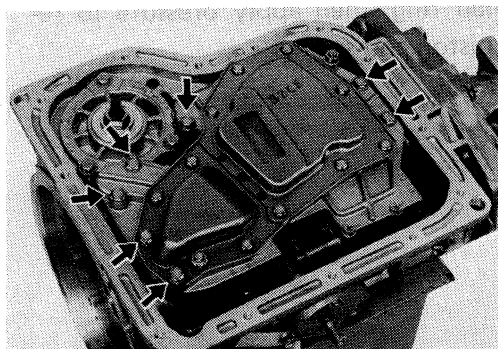

18. Remove control valve body.

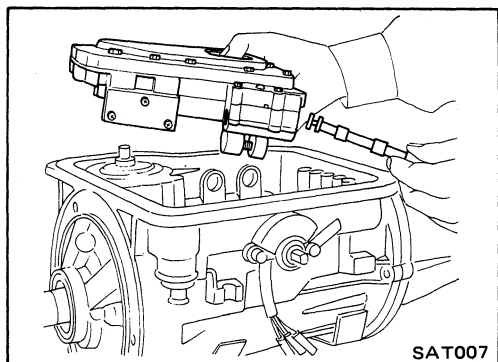

- Remove manual valve from valve body as a precaution, to prevent valve from dropping out accidentally.

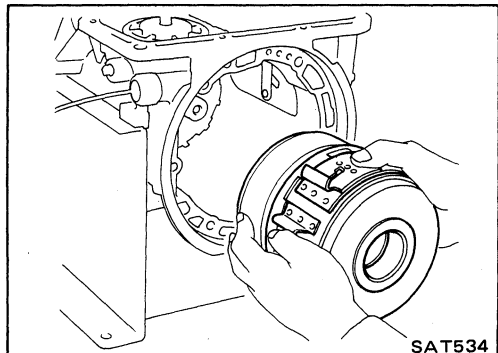

19. Remove 2nd brake band strut. Brake band and clutch & planetary gear pack [including front clutch, rear clutch and front planetary gear] may be removed together.

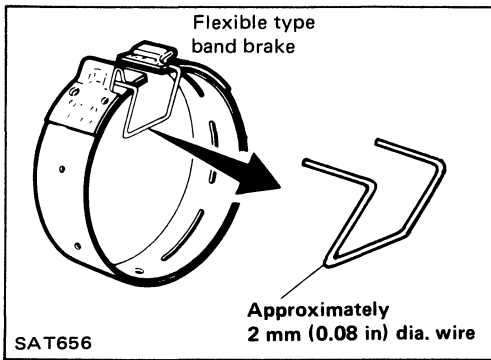

- To prevent brake linings from cracking or peeling, do not stretch the flexible band unnecessarily. Before removing the brake band, always secure it with a clip as shown in the figure to the left.

Leave the clip in position after removing the brake band.

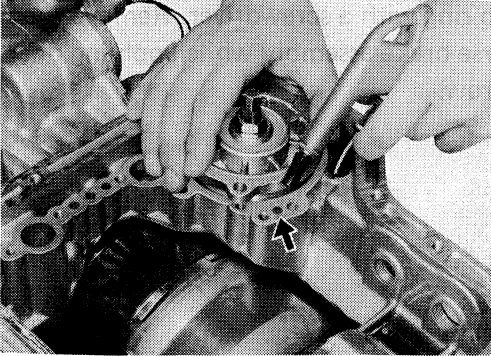

20. Remove 2nd band servo retaining bolts. Apply pressure to remove 2nd band servo.

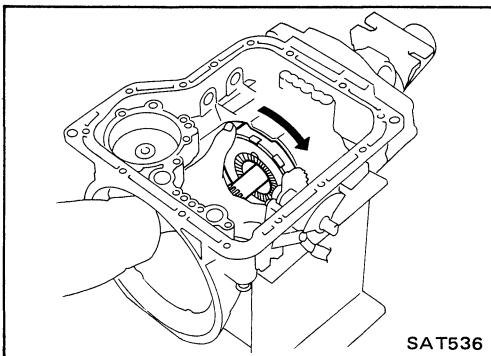

21. Check one-way clutch to see if it operates properly.

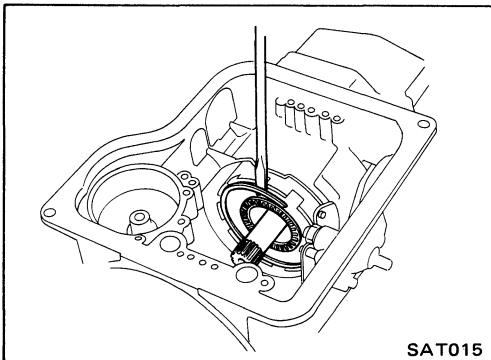

22. Remove rear planetary carrier snap ring and rear planetary carrier.

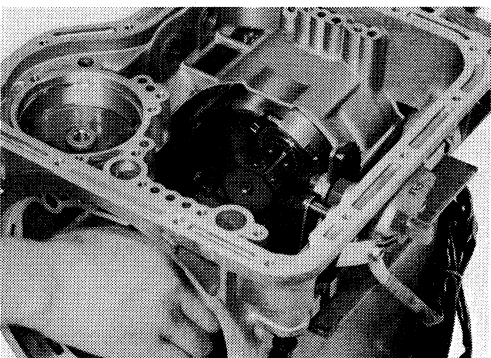

23. Remove output shaft snap ring.

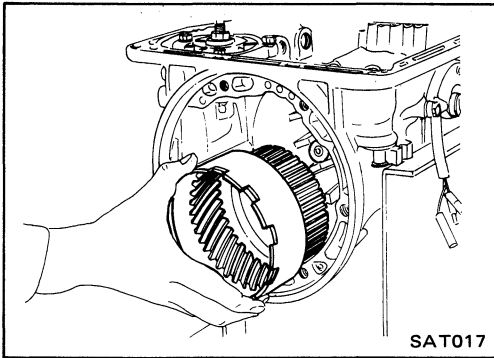

24. Remove connecting drum with internal gear.

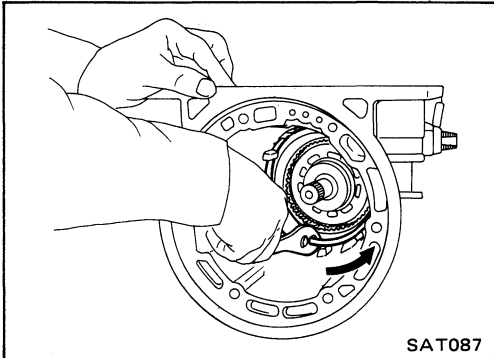

25. Pry off one end of snap ring with a screwdriver. Remove snap ring from low and reverse brake assembly while applying plier force in direction of arrow.

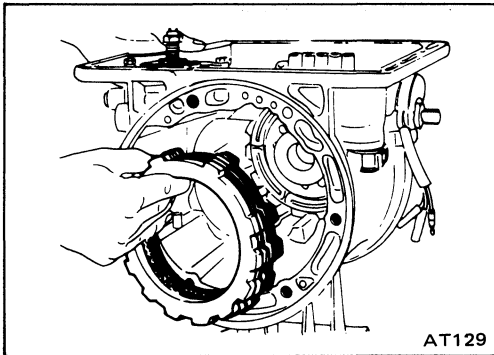

26. Remove low and reverse brake clutch assembly.

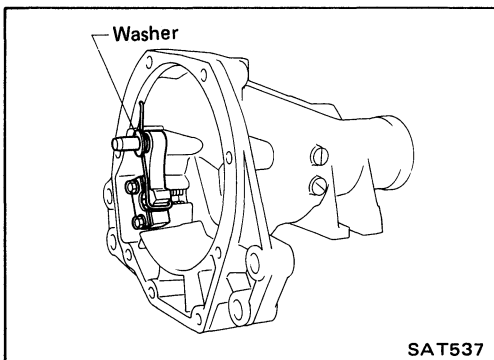

27. Remove rear extension.
Be careful not to lose retainer washer.

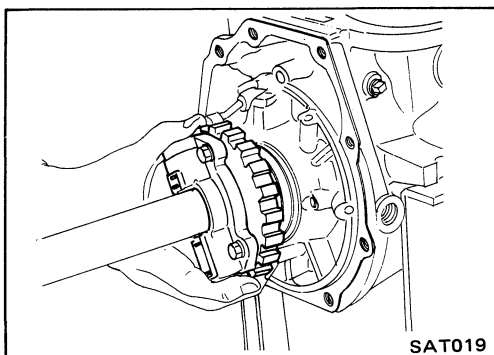

28. Remove output shaft with governor.

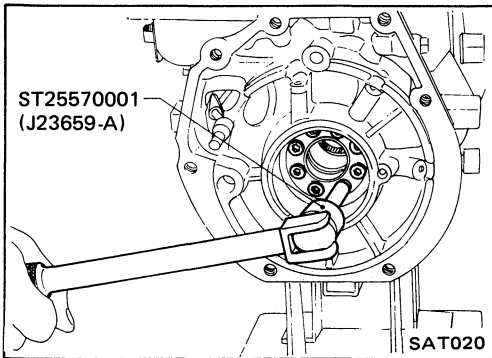

29. Remove governor thrust washer and needle bearing.
Remove one-way clutch inner race attaching hex-head slotted bolts using Tool.

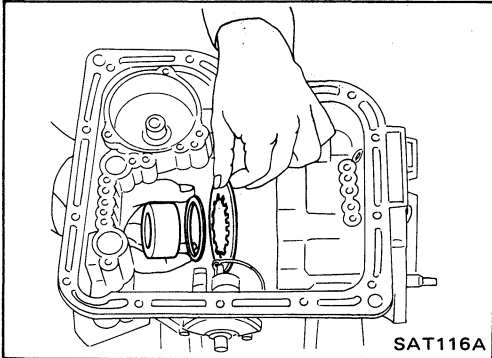

30. Remove one-way clutch inner race, return thrust washer, low and reverse return spring.

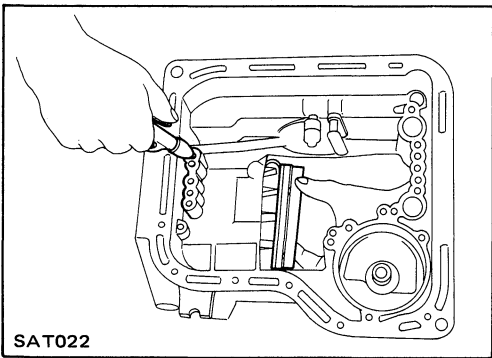

31. Apply air pressure to remove low and reverse brake piston.

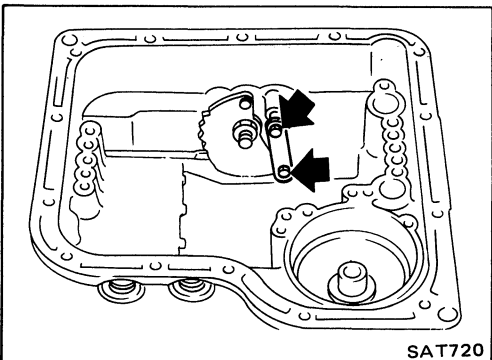

32. Remove snap ring, then remove lock nut, manual plate and parking rod.

33. Remove inhibitor switch and manual shaft.
34. Remove O.D. indicator switch and O-ring.

Oil Pump

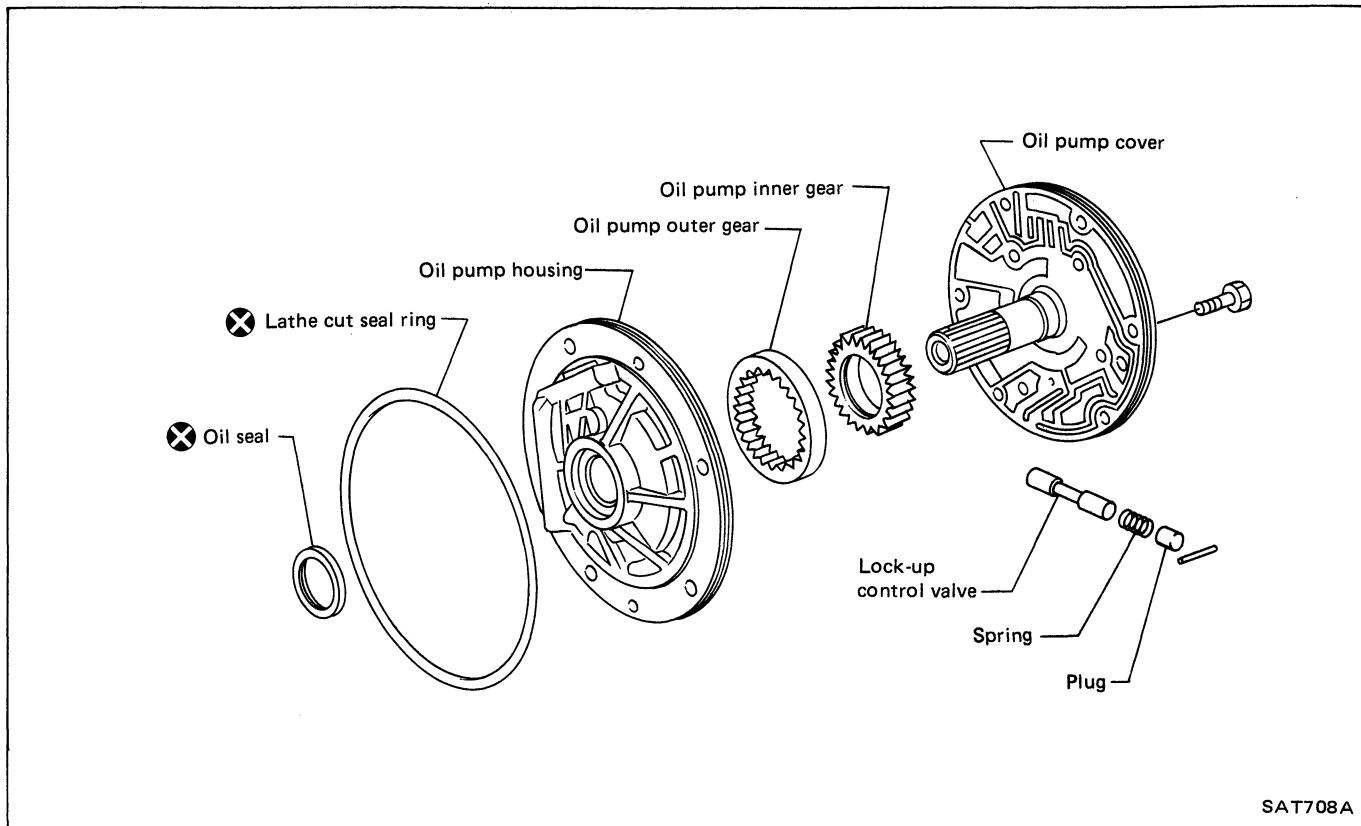

SAT708A

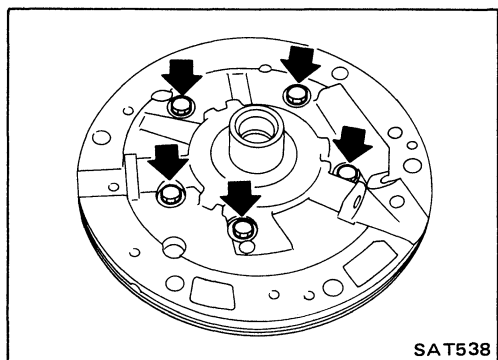

SAT538

DISASSEMBLY

1. Remove pump cover from pump housing.

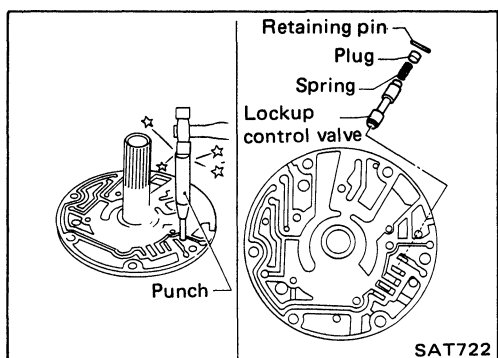

SAT722

2. Stake off retaining pin using a punch [outer dia. 1.5 to 1.8 mm (0.059 to 0.071 in)], then remove lockup control valve and spring.

Oil Pump (Cont'd)

INSPECTION

1. Inspect pump body, bushing and pump shaft, for wear.
2. Inspect gears, lockup control valve, spring and all internal surfaces for damage and visible wear.

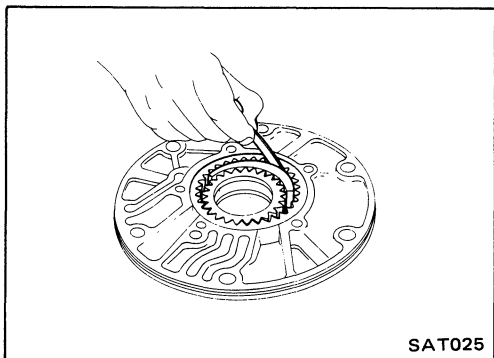

3. Measure clearance between outer gear and crescent.

Standard clearance:

0.14 - 0.21 mm (0.0055 - 0.0083 in)

Wear limit:

0.25 mm (0.0098 in)

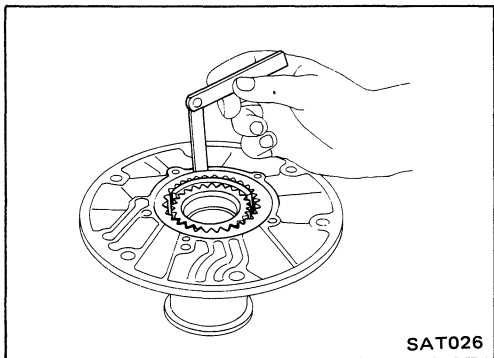

4. Measure clearance between outer gear and pump housing.

Standard clearance:

0.05 - 0.20 mm (0.0020 - 0.0079 in)

Wear limit:

0.25 mm (0.0098 in)

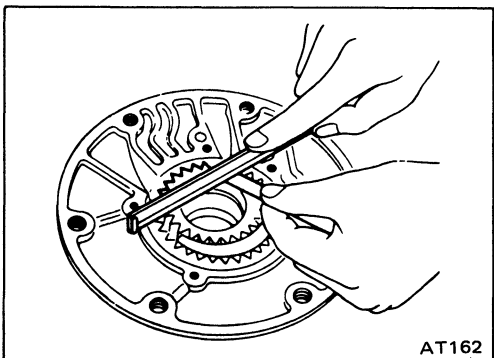

5. Using a feeler gauge and straight edge, measure clearance between gears and pump cover.

Standard clearance:

0.02 - 0.04 mm (0.0008 - 0.0016 in)

Wear limit:

0.08 mm (0.0031 in)

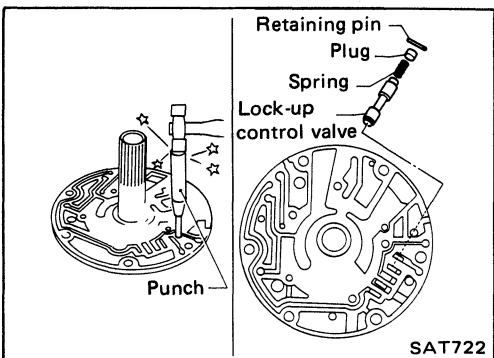

ASSEMBLY

1. Install lockup control valve and spring into oil pump cover, then tap new retaining pin.

Oil Pump (Cont'd)

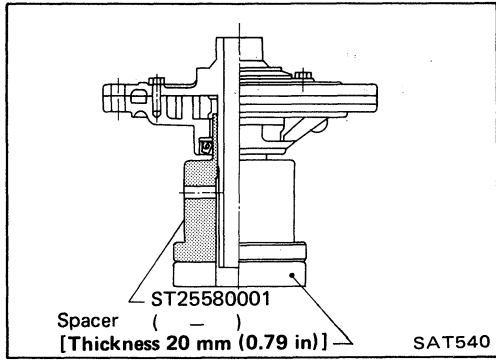

2. Mount pump housing in Tool and suitable spacer. Set up pump housing with inner and outer pump gears on it and install pump cover to pump housing. Temporarily assemble oil pump.

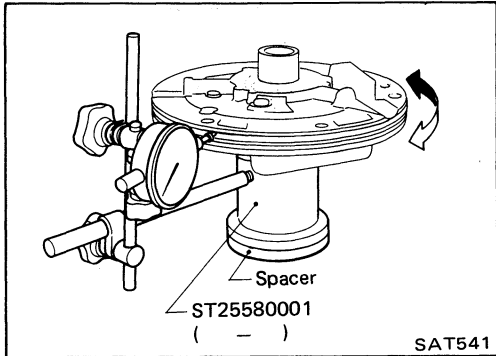

3. Set the cover to within the runout of the specified total indicator reading.

**Total indicator reading:
Less than 0.07 mm (0.0028 in)**

4. Tighten pump securing bolts to the specified torque. Recheck runout.

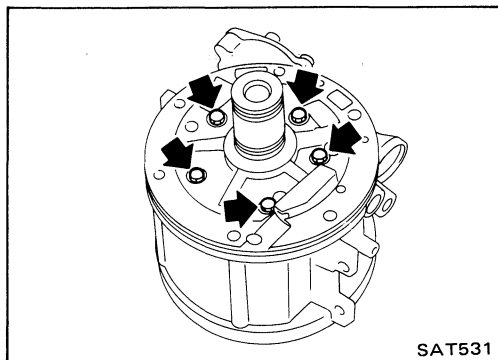

Drum Support

DISASSEMBLY

1. Remove drum support and gasket from O.D. case.

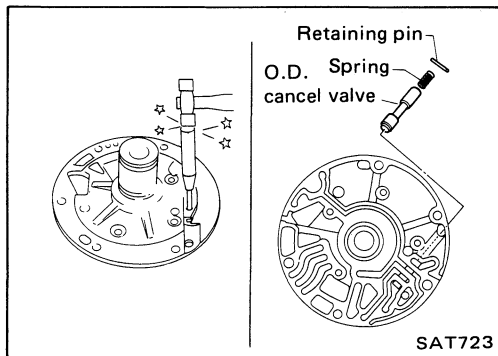

2. Stake off retaining pin using a punch [outer dia. 1.5 to 1.8 mm (0.059 to 0.071 in)], then remove O.D. cancel valve and spring.

Don't stake it off from contacting face side.

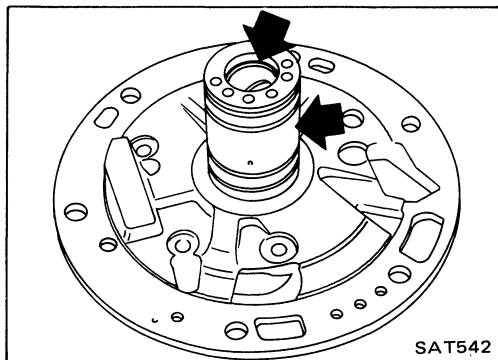

INSPECTION

- Inspect drum support bushing and ring groove areas for wear.

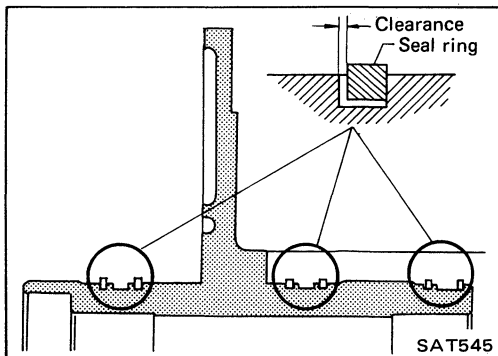

- Measure clearance between seal ring and ring groove.

Standard clearance:

0.05 - 0.20 mm (0.0020 - 0.0079 in)

Wear limit:

0.20 mm (0.0079 in)

- Inspect O.D. cancel valve & spring and all internal surfaces for damage visible wear.

Drum Support (Cont'd)

ASSEMBLY

1. Install O.D. Spring and spring into drum support, then tap new retaining pins.

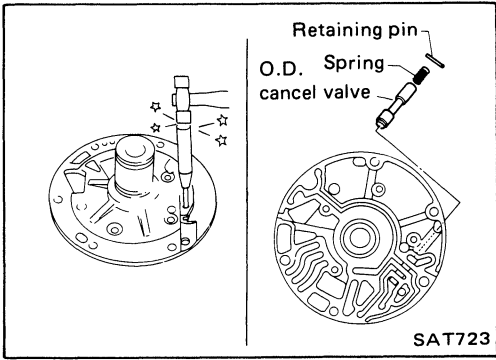

2. Install lubrication plug in drum support.

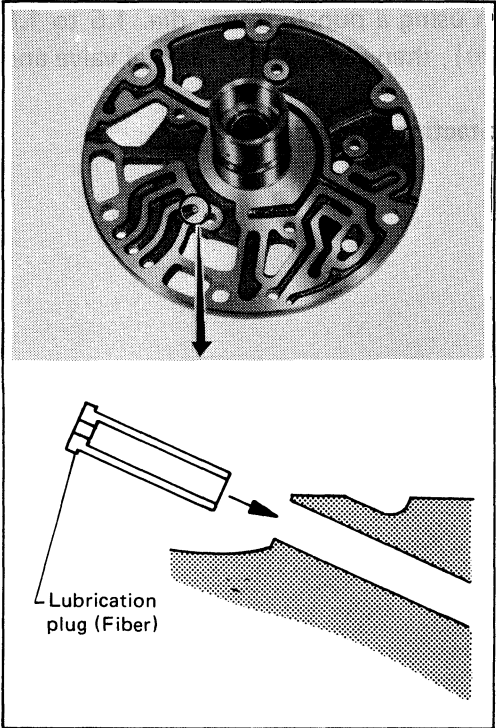

3. Install one-way orifice in O.D. case.

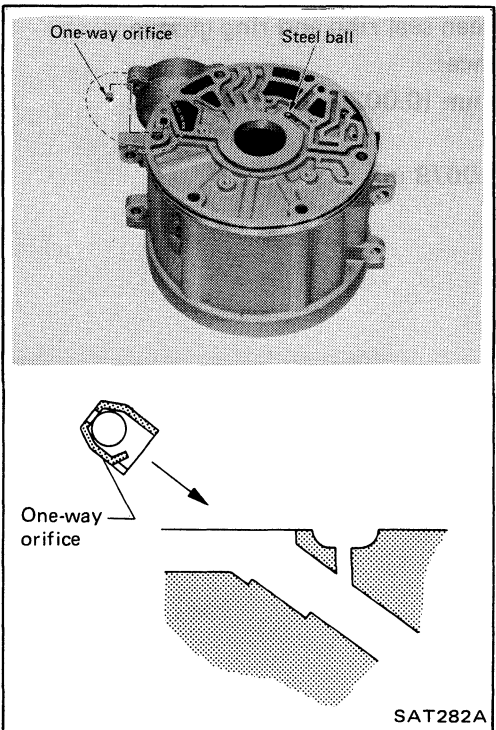

Drum Support (Cont'd)

4. Mount oil pump assembly in Tool and suitable spacer.

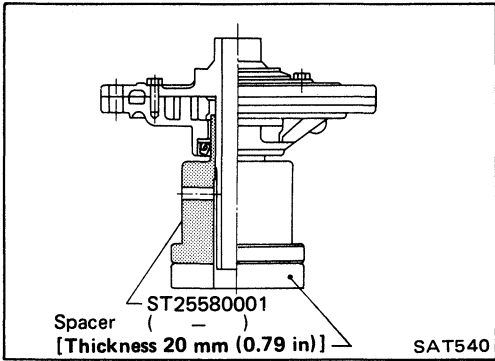

5. Mount O.D. case, drum support and gasket in oil pump assembly.

Ensure O.D. case is inserted properly into oil pump assembly.

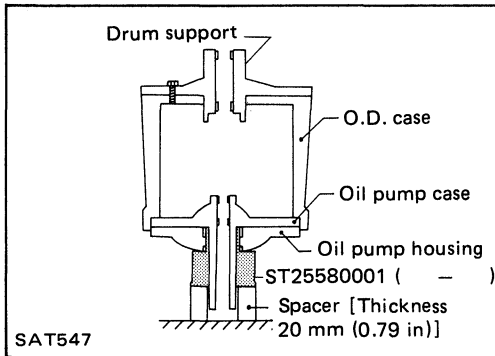

Drum Support (Cont'd)

6. Loosen drum support bolts before inserting Tool (J33909).

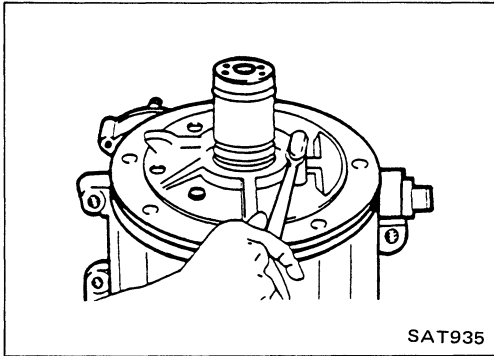

7. Insert the tapered edge of Tool and install Tool until it completely passes through O.D. case.

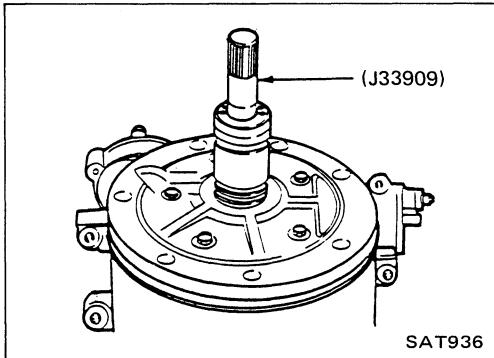

8. Rotate Tool to ensure proper alignment.

9. Tighten drum support bolts while Tool is inside O.D. case.

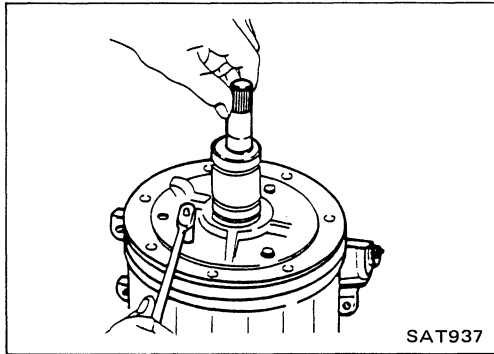

10. Remove Tool (J33909).

11. Check that the drum support is within the run-out of the specified total indicator reading.

Total indicator reading:

Less than 0.05 mm (0.0020 in)

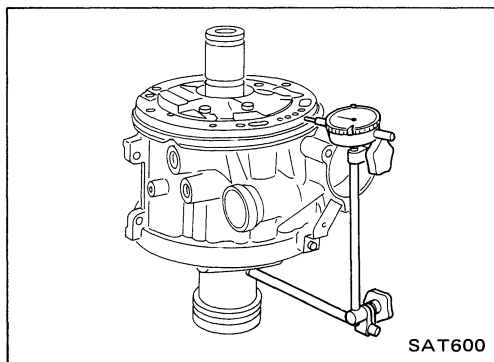

Control Valve Body

Upper body side

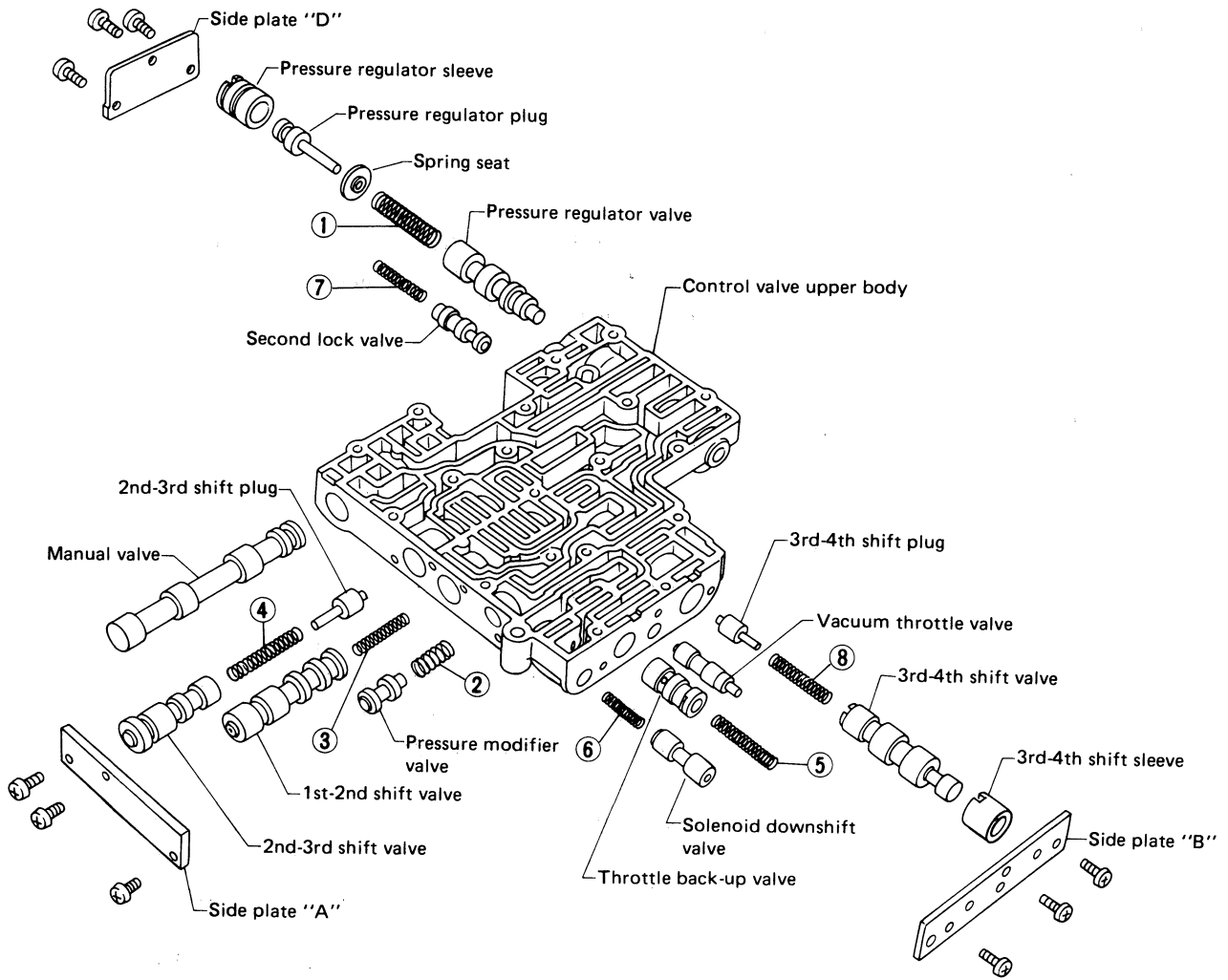

Lower body side

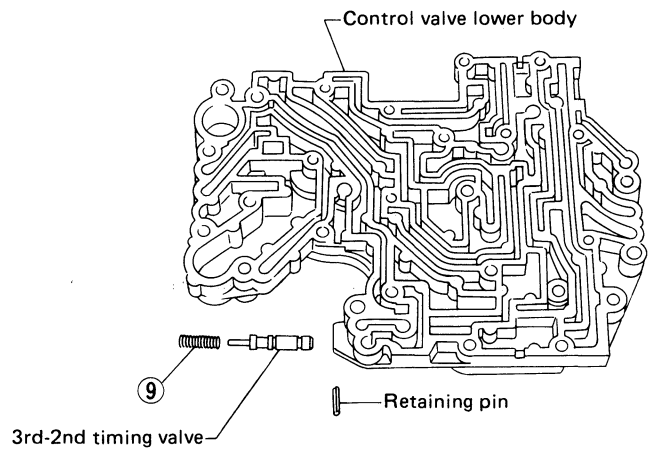

Control Valve Body (Cont'd)**DISASSEMBLY**

1. Remove oil strainer.

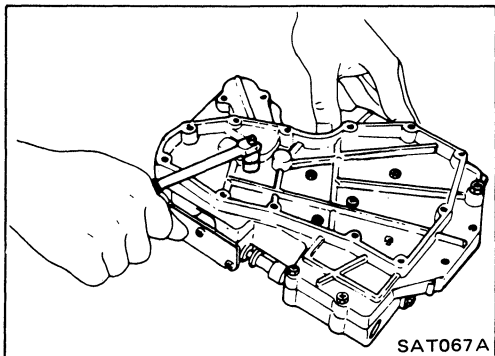
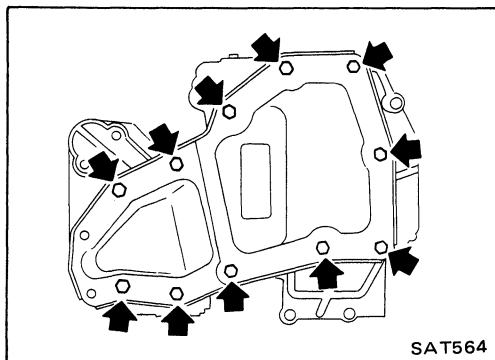

2. Separate lower body, separator plate and upper body.

Be careful not to scatter or lose orifice check valve, servo orifice check valve, or throttle relief check valve (ball) and related springs.

INSPECTION

- If inspection reveals excessive clearances, 0.03 mm (0.0012 in) or more, between the valves and the valve body bores, replace the entire valve body.
 - Always use crocus cloth, which is a very fine type of cutting material.
 - During cleaning, do not remove the sharp edges of the valve.
 - The valves may be cleaned using alcohol or lacquer thinner. The valve bodies can be dip cleaned with a good carburetor cleaner or lacquer thinner. Do not leave valve bodies submerged in carburetor cleaner longer than five minutes.
 - Lubricate all parts in clean A.T.F. before reassembly.
1. Check valves for signs of burning. Replace if beyond clean-up.

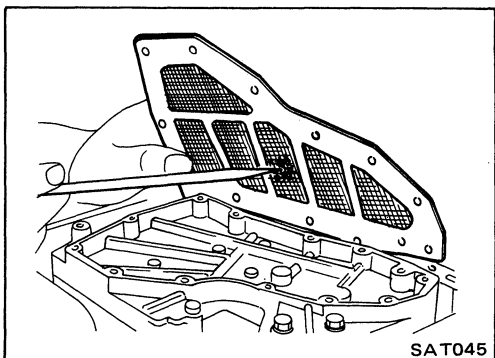

2. Check oil strainer for general condition. Replace if necessary.

Control Valve Body (Cont'd)

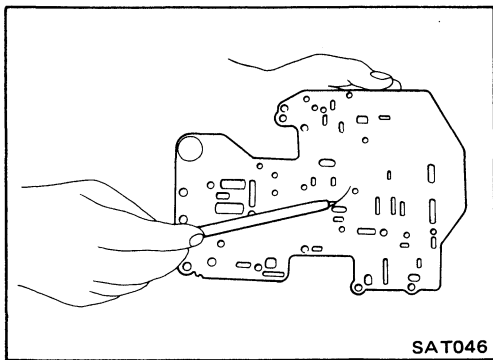

3. Check separator plate for scratches or damage. Replace if necessary. Scratches or score marks can cause oil to by-pass correct oil passages and result in system malfunction.

4. Check oil passages in upper and lower valve bodies for varnish deposits, scratches or other damage that would impair valve movement. Check threaded holes and related bolts and screws for stripped threads; replace as needed.

5. Check valve springs for damage. Measure free length of valve springs. If the free length is out of specification, replace it. Numbers of each valve spring listed in table below are the same as those in the figure on page AT-93.

Valve spring	Free length mm (in)	
① Pressure regulator valve	43.0 (1.693)	
② Pressure modifier valve	18.5 (0.728)	
③ 1st-2nd shift valve	Z24i	32.0 (1.260)
	VG30i	29.4 (1.157)
④ 2nd-3rd shift valve	41.0 (1.614)	
⑤ Throttle back-up valve	Z24i	36.0 (1.417)
	VG30i	31.8 (1.252)
⑥ Solenoid downshift valve	22.0 (0.866)	
⑦ Second lock valve	33.5 (1.319)	
Throttle relief check valve	26.8 (1.055)	
Orifice check valve	15.5 (0.610)	
⑧ 3rd-4th shift valve	30.3 (1.193)	
⑨ 3rd-2nd timing valve	Z24i	22.7 (0.894)
	VG30i	23.2 (0.913)

Control Valve Body (Cont'd)

ASSEMBLY

1. Install orifice check valves, valve springs, throttle relief valve spring and steel ball in valve body.

Orifice check valve

Unit: mm (in)

Orifice check valve	Diameter "A"	Identification
2nd servo release	Z24i	Green
	VG30i	Gold
Front clutch applies	2.2 (0.087)	Black

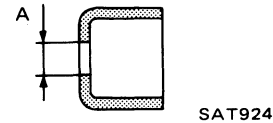
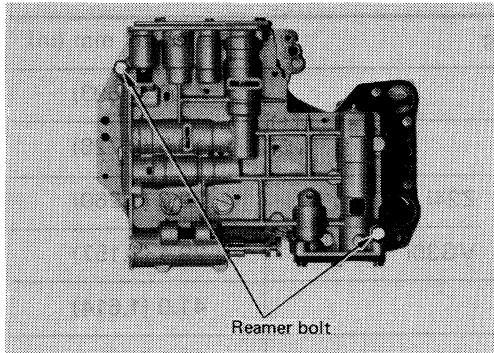
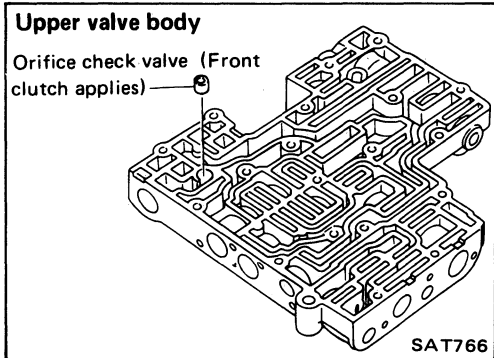
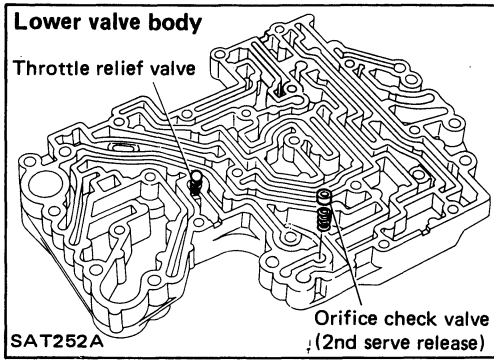

2. Assemble separator plate and upper valve body on lower valve body, then tighten bolts.

When installing these bolts, first be sure to install the two reamer bolts to their original positions.

3. Install oil strainer.

Oil Distributor

INSPECTION

- Inspect contacting surface of oil distributor and ring groove areas for wear.

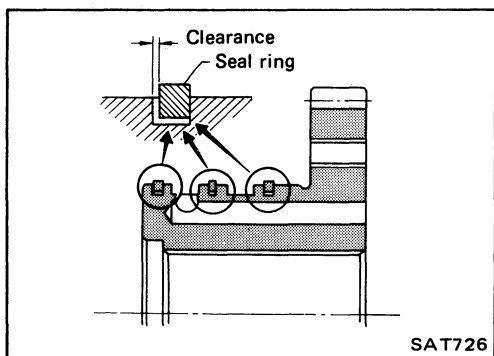
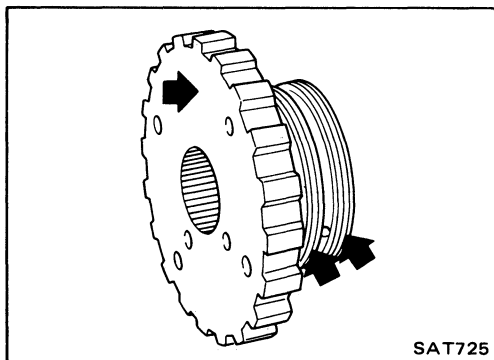

- Measure clearance between seal ring and ring groove.

Standard clearance:

0.04 - 0.16 mm (0.0016 - 0.0063 in)

Wear limit:

0.16 mm (0.0063 in)

Direct Clutch

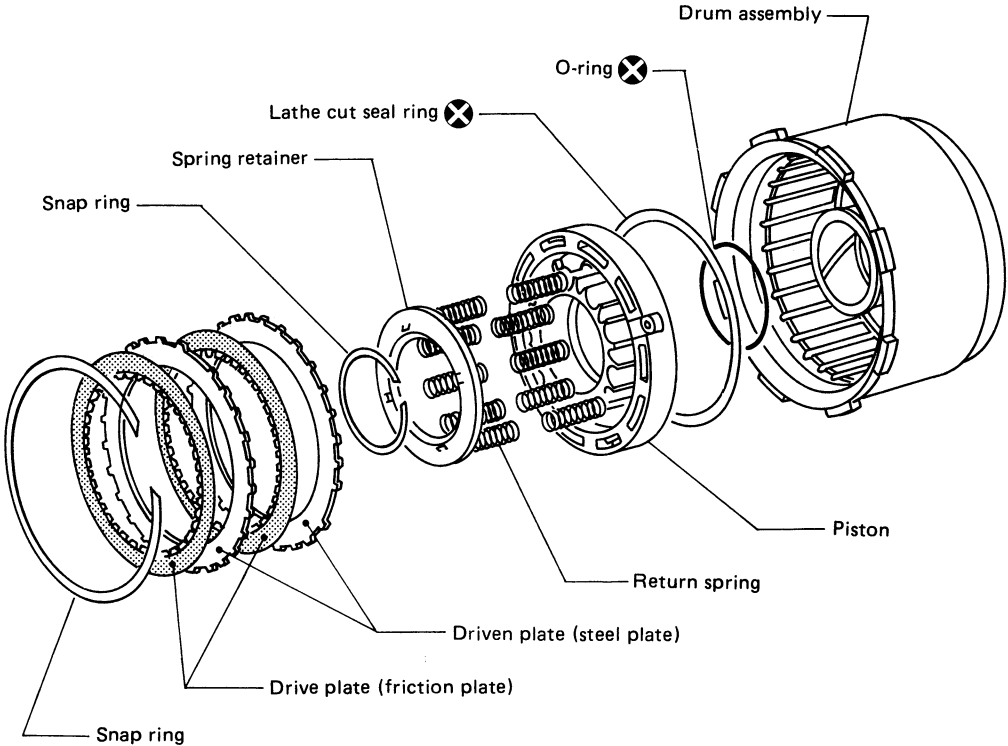

SST228A

Direct Clutch (Cont'd)

DISASSEMBLY

- Compress clutch springs and remove snap ring from spring retainer with Tool.

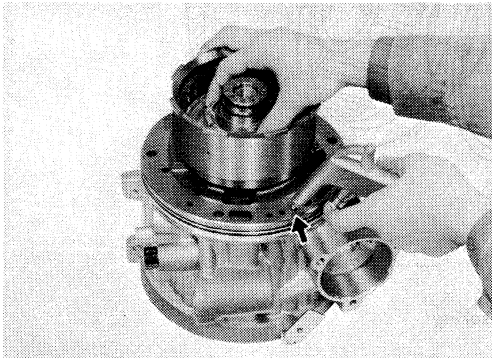
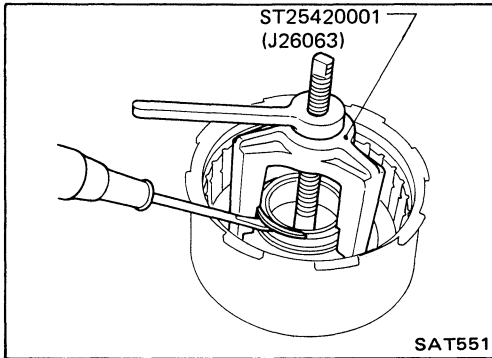

- For easy removal of piston from drum, mount clutch on drum support. Use an air gun with a tapered rubber cup to carefully apply air pressure to loosen piston from drum.

INSPECTION AND ASSEMBLY

1. Check clutch drive plate facing for wear or damage.

Standard thickness:

1.50 - 1.65 mm (0.0591 - 0.0650 in)

Wear limit:

1.4 mm (0.055 in)

2. Check for wear on snapping, weak or broken coil springs, and warped spring retainer.

3. Check the operation of check ball in piston using compressed air.

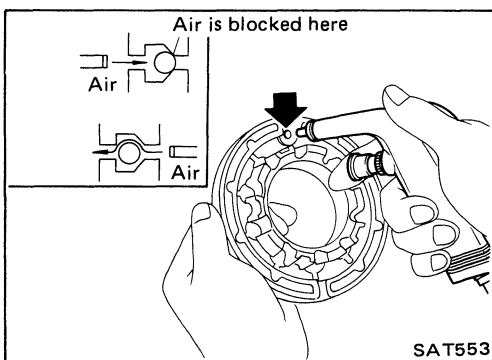

4. Lubricate clutch drum hub and seals, and install inner seal and piston seal as illustrated. Be careful not to stretch seals during installation.

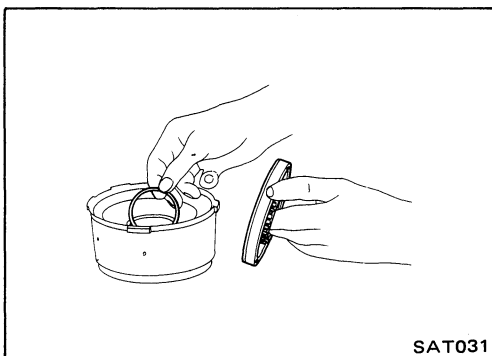

Direct Clutch (Cont'd)

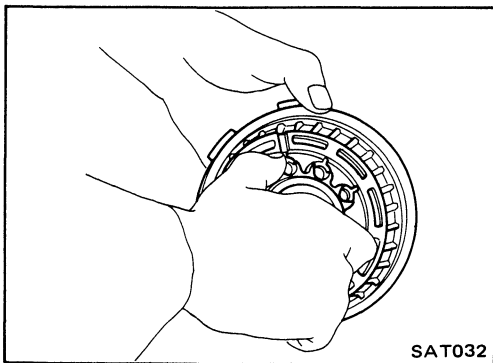

5. Assemble piston, being careful not to allow seal to kink or become damaged during installation. After installing, turn piston by hand to ensure that there is no binding.

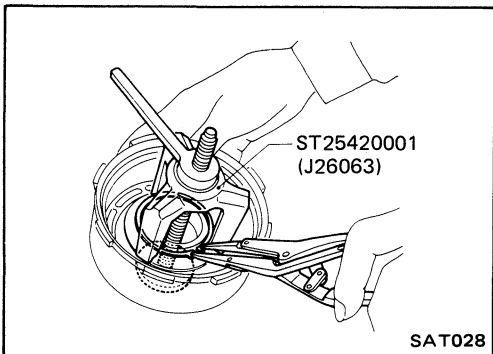

6. Reassemble spring and retainer. Reinstall snap ring. Be sure snap ring is properly seated.

- 7. Install driven plates, drive plates, and secure with snap ring.
- 8. Install retainer plate, O.D. one-way clutch assembly race side, and secure with snap ring.

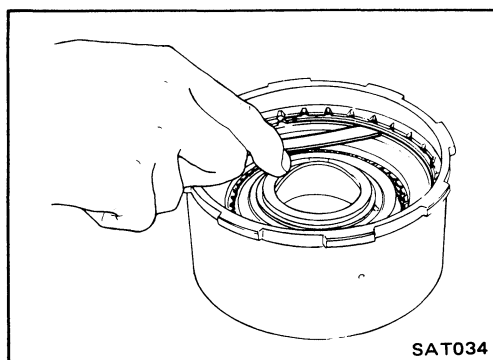

9. Measure clearance between race side and snap ring.

Specified clearance:

0 - 0.2 mm (0 - 0.008 in)

If necessary, try other race side having different thicknesses until correct clearance is obtained.

Thickness mm (in)	Part number
0.4 (0.016)	31606-X8501
0.6 (0.024)	31606-X8502
0.8 (0.031)	31606-X8500
1.0 (0.039)	31606-X8503
1.2 (0.047)	31606-X8504

Direct Clutch (Cont'd)

10. Testing direct clutch

With direct clutch assembled on drum support, direct a jet of air into hole in clutch drum for definite clutch operation.

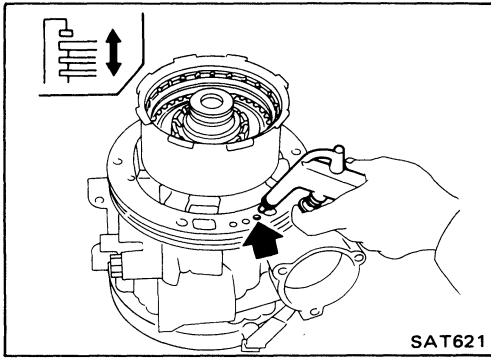

Front Clutch

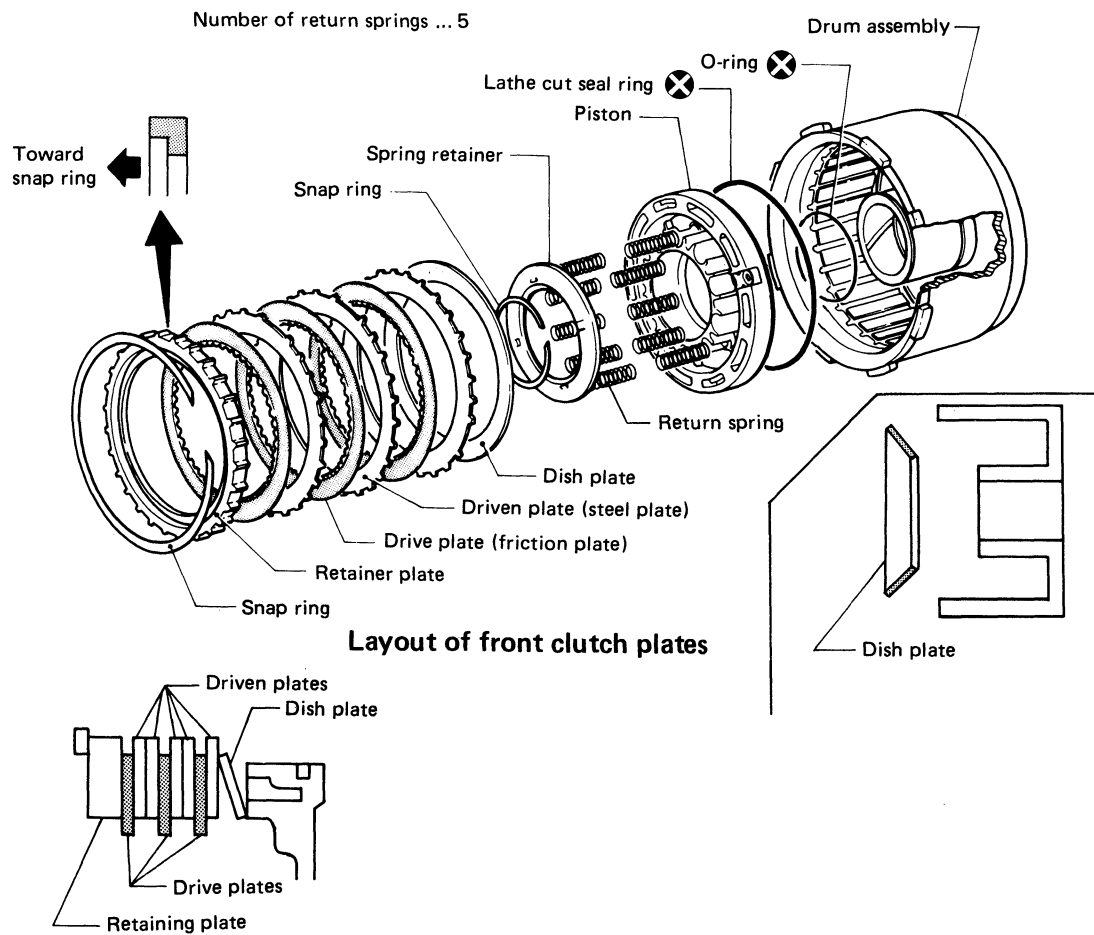

SAT348A

Front Clutch (Cont'd)

DISASSEMBLY

- Compress clutch springs and remove snap ring from spring retainer with Tool.

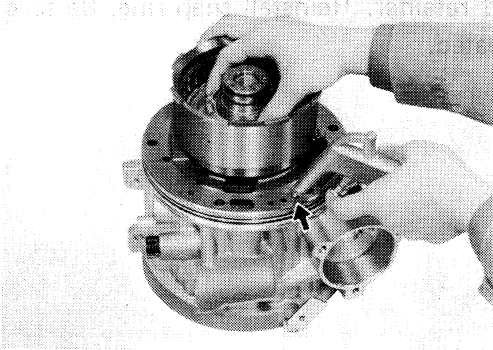
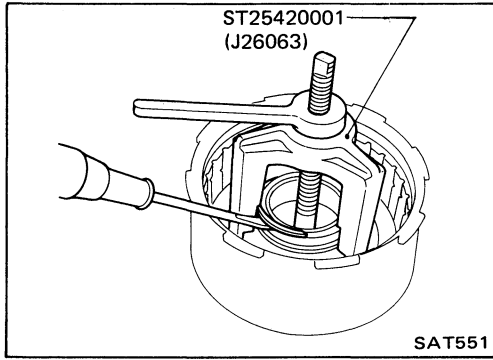

- For easy removal of piston from drum, mount clutch on drum support. Use an air gun with a tapered rubber up to carefully apply air pressure to loosen piston from drum.

INSPECTION AND ASSEMBLY

1. Check clutch drive plate facing for wear or damage.

Standard thickness:

1.50 - 1.65 mm (0.0591 - 0.0650 in)

Wear limit:

1.4 mm (0.055 in)

2. Check for wear on snapping, weak or broken coil springs, and warped spring retainer.

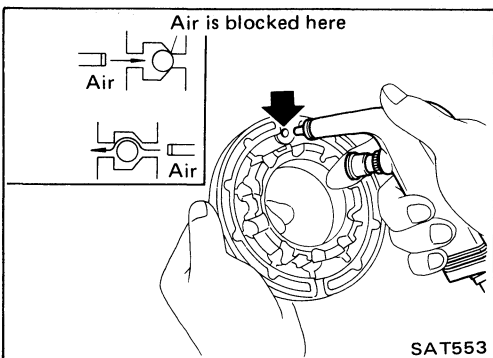

3. Check the operation of check ball in piston using compressed air.

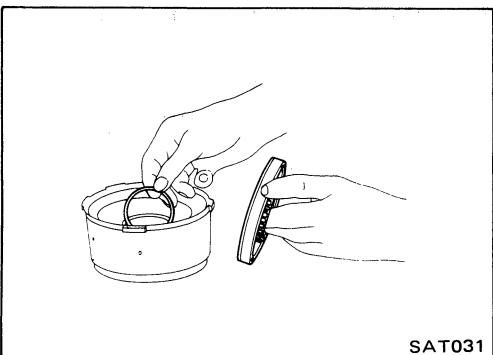

4. Lubricate clutch drum hub and seals, and install inner seal and piston seal as illustrated. Be careful not to stretch seals during installation.

Front Clutch (Cont'd)

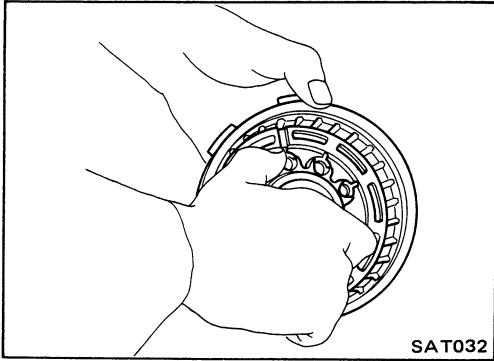

5. Assemble piston, being careful not to allow seal to kink or become damaged during installation. After installing, turn piston by hand to ensure that there is no binding.

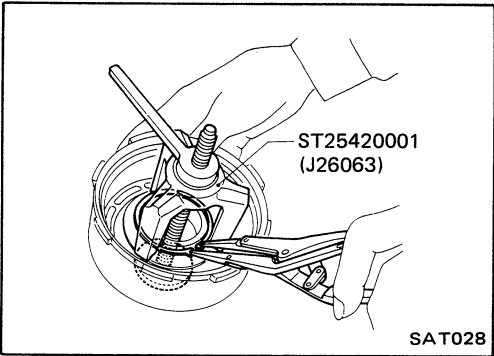

6. Reassemble spring and retainer. Reinstall snap ring. Be sure snap ring is properly seated.

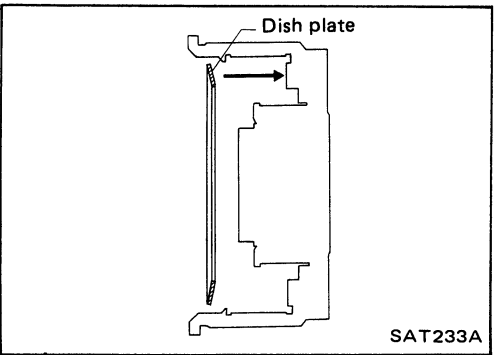

7. Install dish plate.

8. Install driven plates, drive plates, and secure with snap ring.

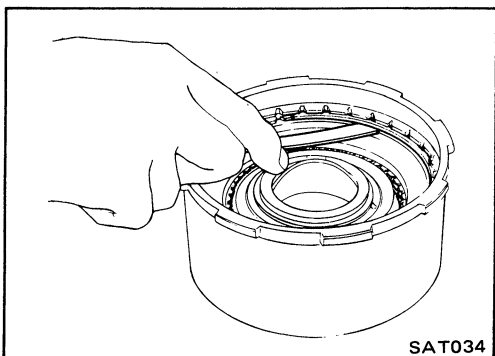

9. Measure clearance between retainer plate and snap ring.

Specified clearance:

1.6 - 1.8 mm (0.063 - 0.071 in)

If necessary, try other retaining plates having different thicknesses until correct clearance is obtained.

Front Clutch (Cont'd)

Available retaining plate

Thickness mm (in)	Part number
5.0 (0.197)	31567-X2900
5.2 (0.205)	31567-X2901
5.4 (0.213)	31567-X2902
5.6 (0.220)	31567-X2903
5.8 (0.228)	31567-X2904
6.0 (0.236)	31567-X2905
6.2 (0.244)	31567-X2906

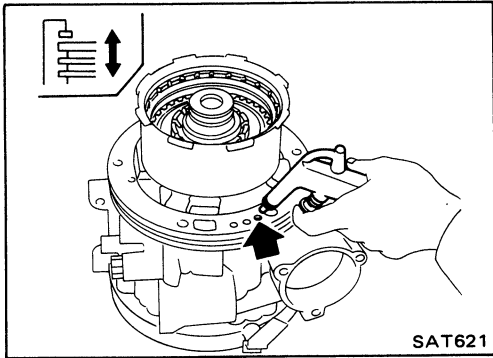

10. Testing front clutch. (Refer to Oil Channel in MAJOR OVERHAUL.)

Rear Clutch

In regard to the number of clutch sheets (drive plate and driven plate), refer to S.D.S.

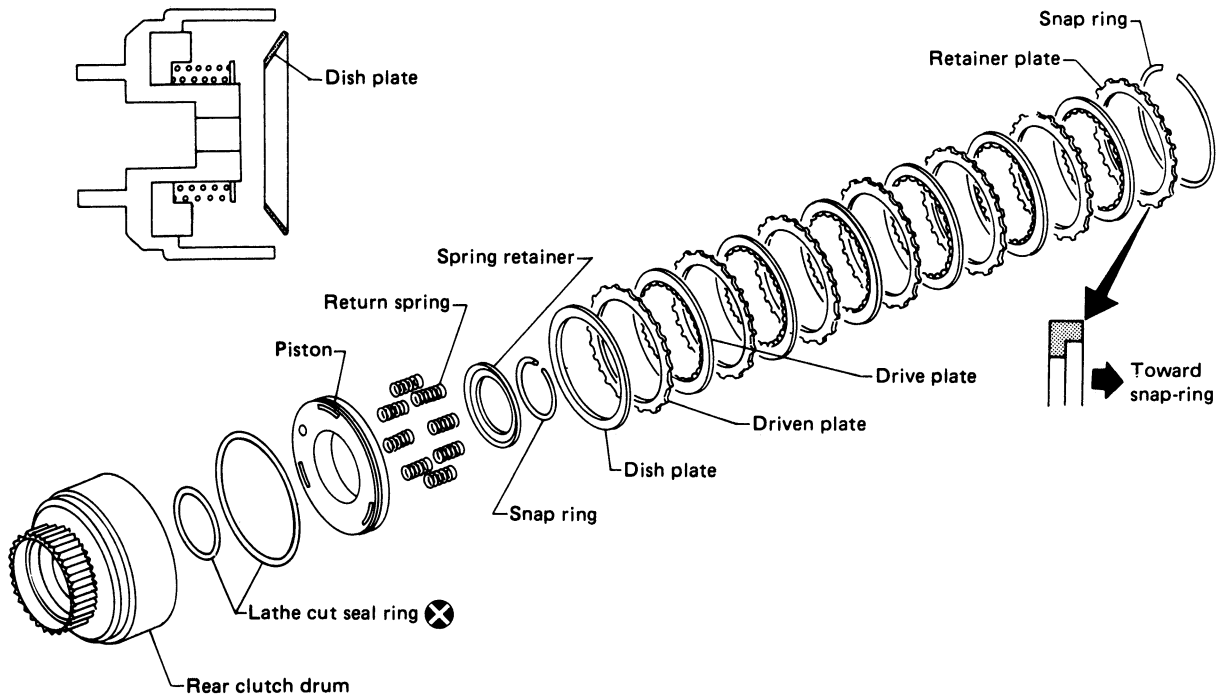

SAT728

Rear Clutch (Cont'd)

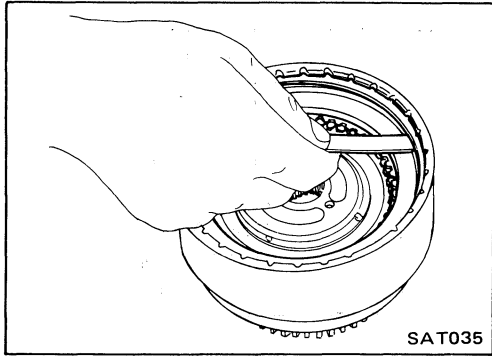

- Service procedures for rear clutch are essentially the same as those for front clutch, with the following exception:
- I. Specified clearance between retainer plate and snap ring:
0.8 - 1.0 mm (0.031 - 0.039 in)

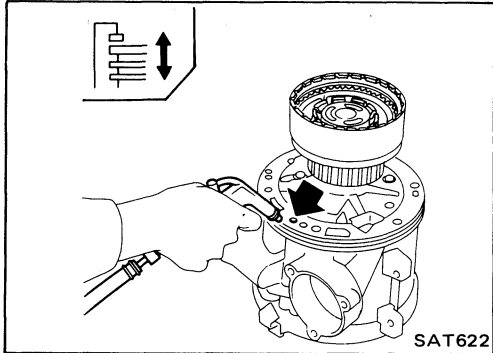

- II. Testing rear clutch (Refer to Oil Channel in MAJOR OVERHAUL.)

Low & Reverse Brake

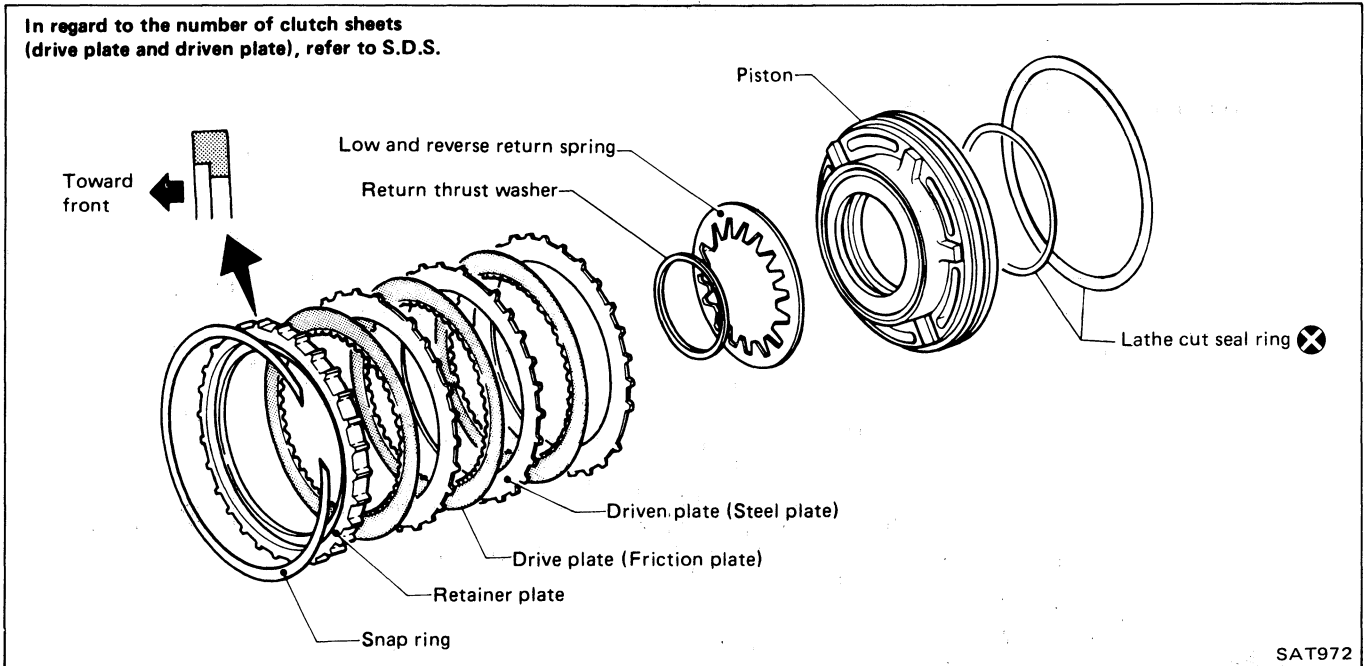

INSPECTION

- Examine for damaged drive plate facing and worn snap ring.
- Check drive plate facing for wear; if necessary, replace.

Drive plate thickness:

Standard

1.90 - 2.05 mm (0.0748 - 0.0807 in)

Allowable limit

1.8 mm (0.071 in)

Brake Band and Band Servo

2nd brake band and band servo

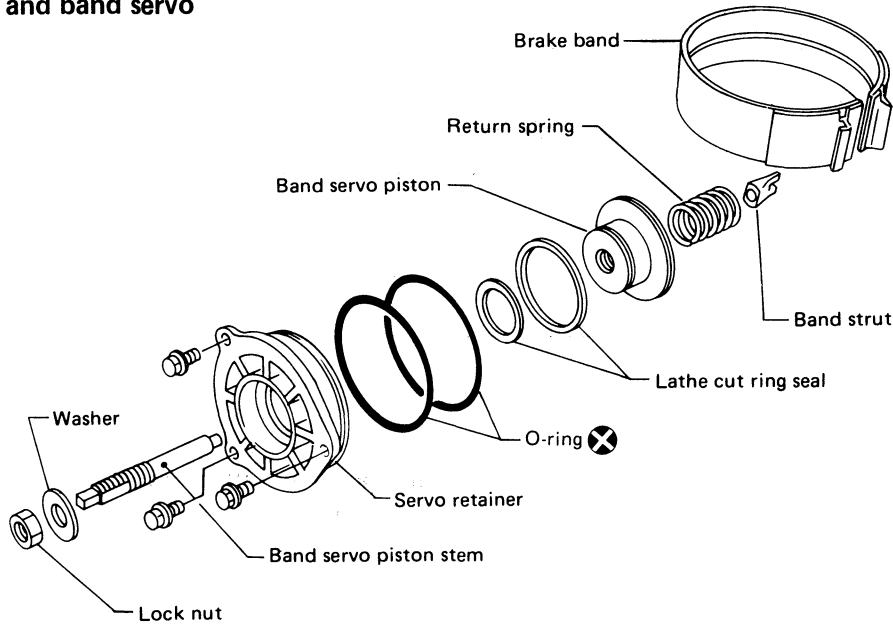

SAT559

O.D. brake band and band servo

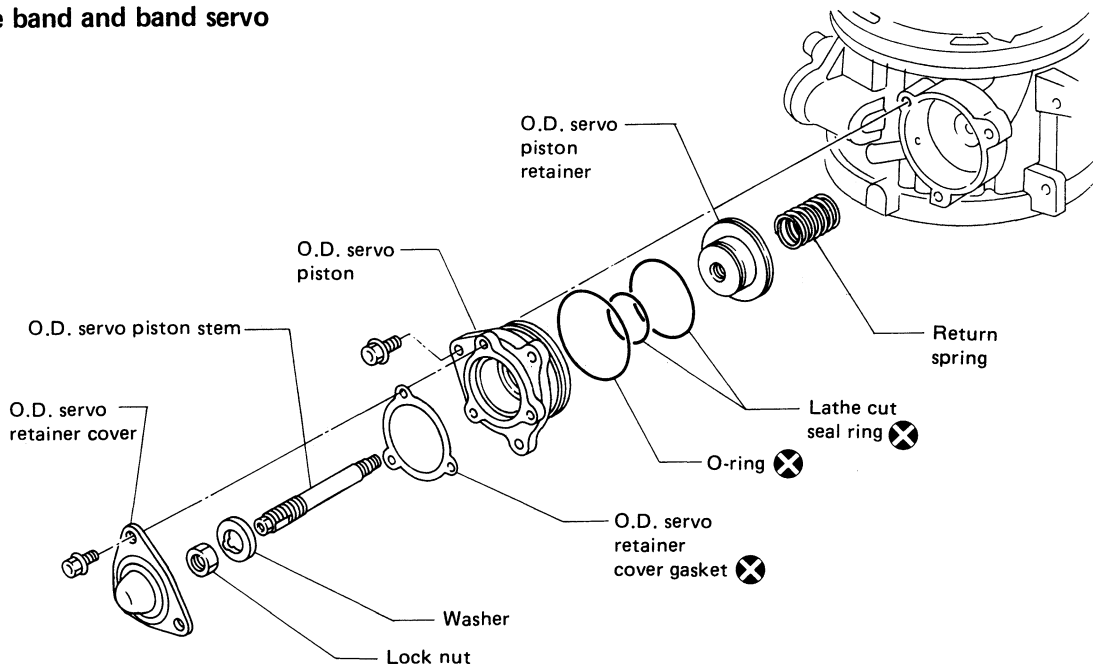

SST231A

INSPECTION

- Inspect band friction material for wear. If cracked, chipped or burnt spots are apparent, replace the band.
- Check band servo components for wear and scoring.

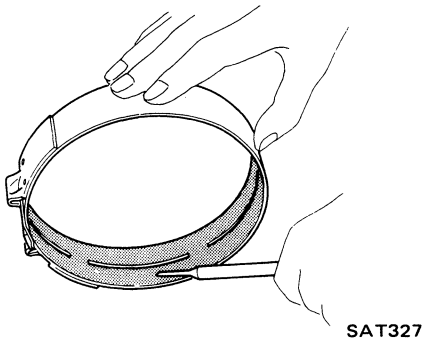

SAT327

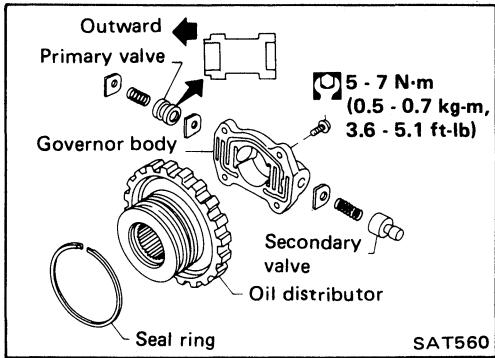

Governor
INSPECTION

- Check governor valves and valve body for indication of burning or scratches.
- Check valve springs for damage.
Measure free length of valve springs.

Valve spring		Free length mm (in)
Primary governor	Z24i	21.8 (0.858)
	VG30i	10.5 (0.413)
Secondary governor	Z24i	25.1 (0.988)
	VG30i	21.7 (0.854)

If any abnormalities are found, replace governor body, valves and springs as an assembly.

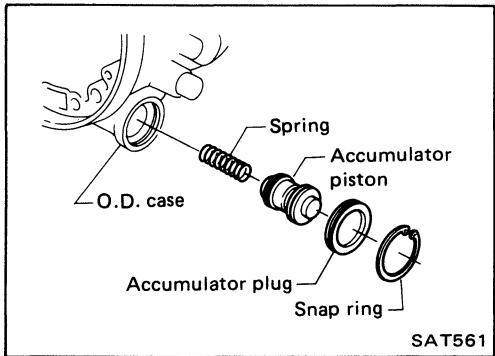

Accumulator

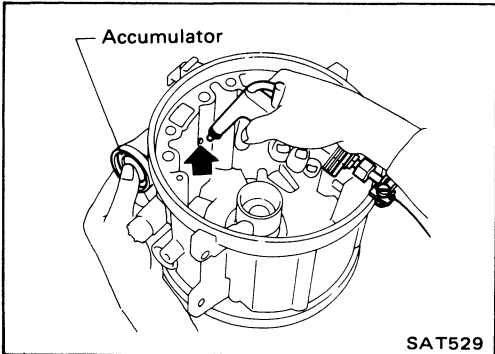

DISASSEMBLY & INSPECTION

- Remove snap ring, then apply pressure to remove accumulator plug, piston and spring.
- Check accumulator components for wear and scoring.

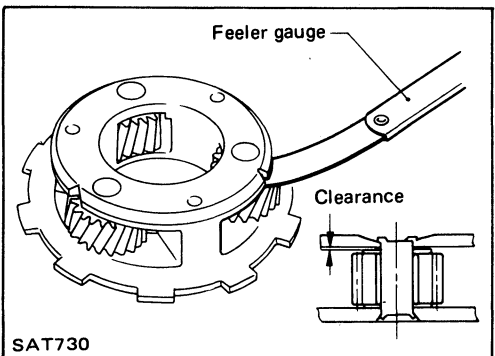

Planetary Carrier
INSPECTION

- Check clearance between pinion washer and planetary carrier with a feeler.

Standard clearance:

0.20 - 0.70 mm (0.0079 - 0.0276 in)

Wear limit:

0.80 mm (0.0315 in)

- Check planetary gear sets and bearings for damaged or worn gears.

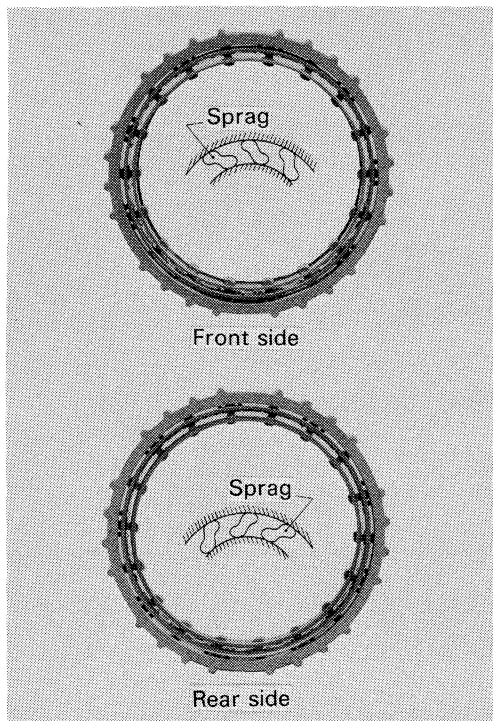
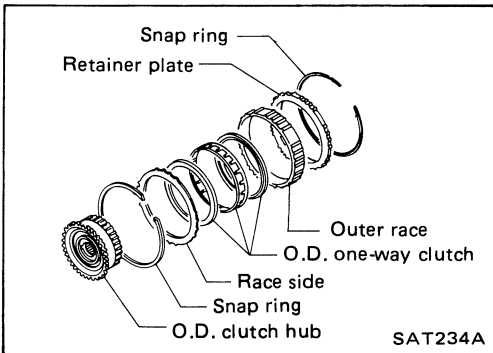
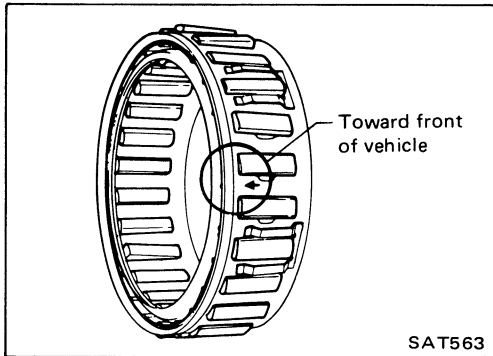
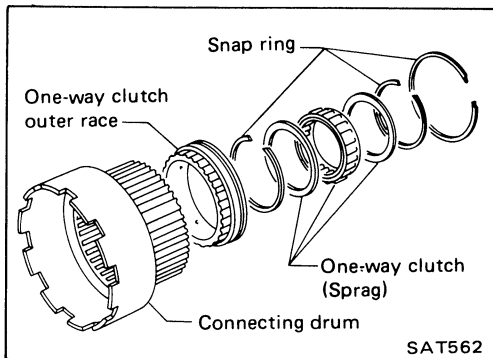

Connecting Drum Assembly

If one-way clutch is out of order as determined during disassembly, repair it as follows:

1. Remove each snap ring, then draw out one-way clutch inner & outer race.
2. Inspect one-way sprag and contacting surface for wear or burns.
Replace parts as necessary.
3. Assemble those parts.

O.D. One-Way Clutch

If one-way clutch is out of order as determined during disassembly, repair it as follows:

1. Remove each snap ring, then draw out one-way clutch assembly.
2. Inspect one-way sprag and contacting surface for wear or burns.
Replace parts as necessary.
3. Assemble those parts.
Pay attention to direction of O.D. one-way clutch.

O.D. One-Way Clutch (Cont'd)

4. After assembly, check O.D. one-way clutch to see if it operates properly.

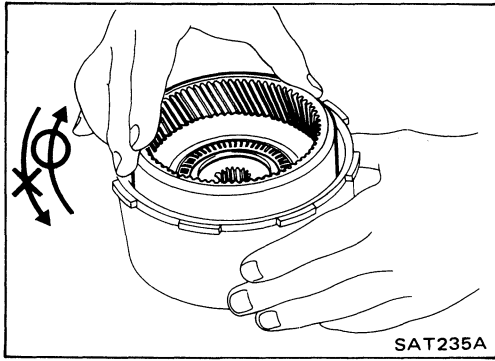

When installing/assembling needle bearing, bearing race, snap ring and thrust washer, use the following illustration as a guide to installation procedures and locations.

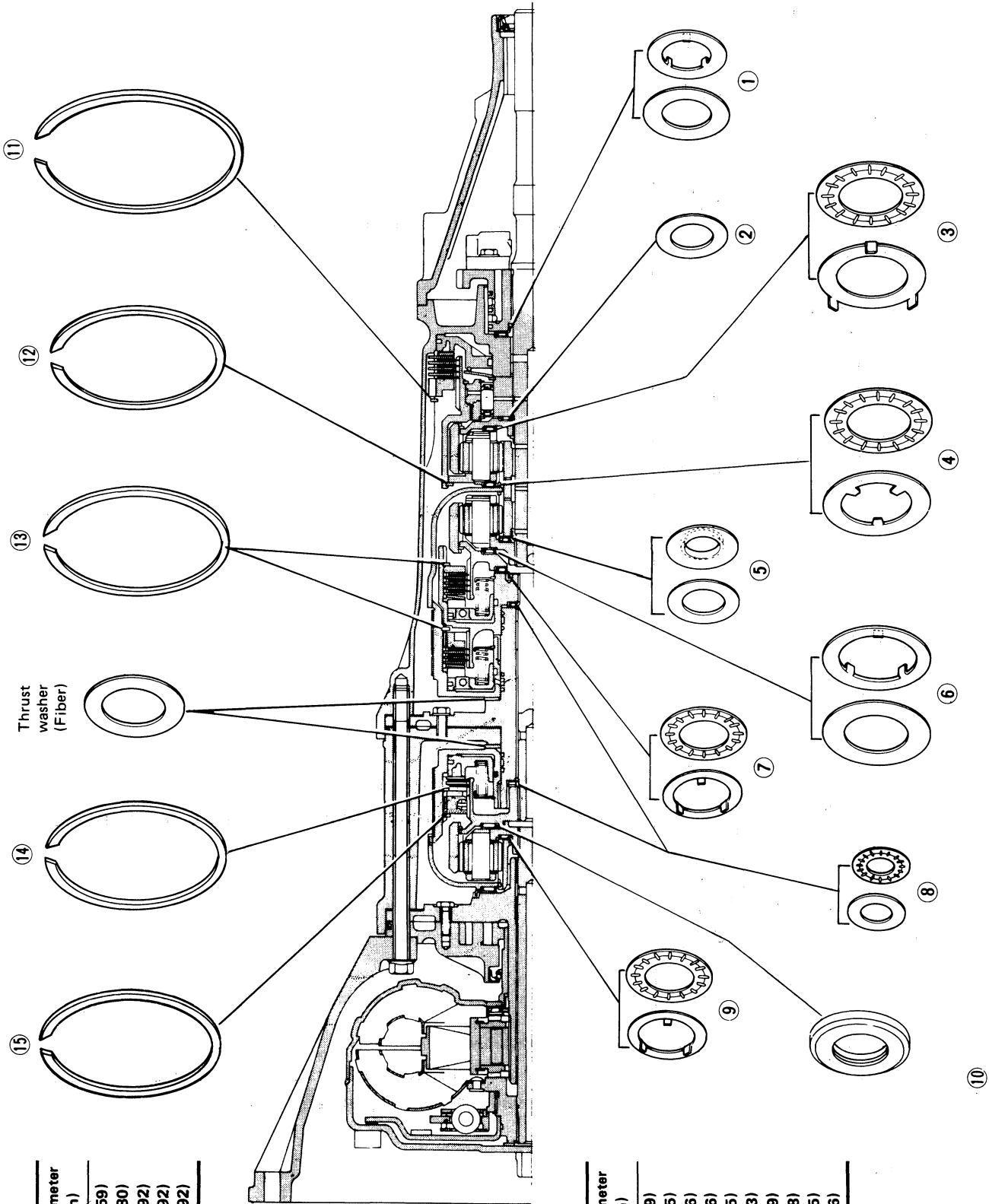

Snap ring	
No.	Outer diameter mm (in)
11	142 (5.59)
12	122 (4.80)
13	125 (4.92)
14	125 (4.92)
15	125 (4.92)

Needle bearing	
No.	Outer diameter mm (in)
1	53 (2.09)
2	47 (1.85)
3	70 (2.76)
4	70 (2.76)
5	47 (1.85)
6	72 (2.83)
7	53 (2.09)
8	35 (1.38)
9	47 (1.85)
10	70 (2.76)

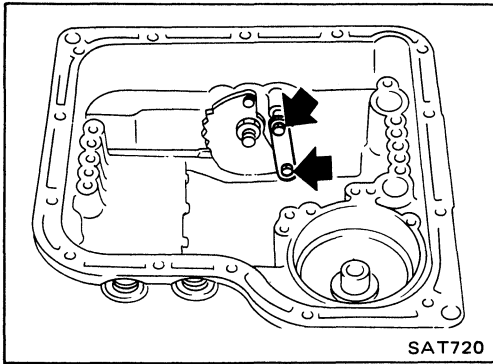

1. Install parking rod, manual plate, manual plate lock nut, parking brake lever and snap rings.

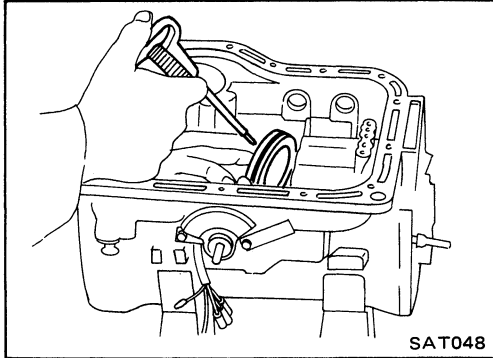

2. Lubricate and install low and reverse piston into the case.

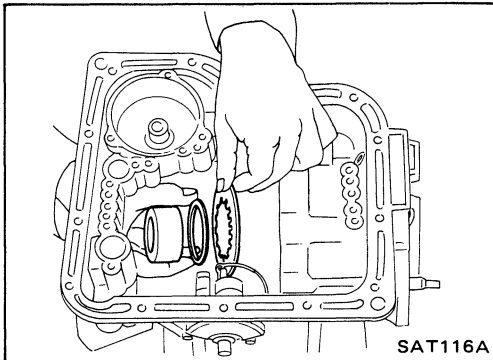

3. Install piston return spring, thrust washer and one-way clutch inner race.

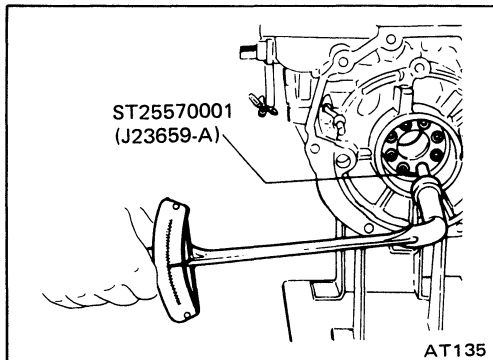

4. Install hex-head slotted bolts.
Check that return spring is centered on race before tightening.

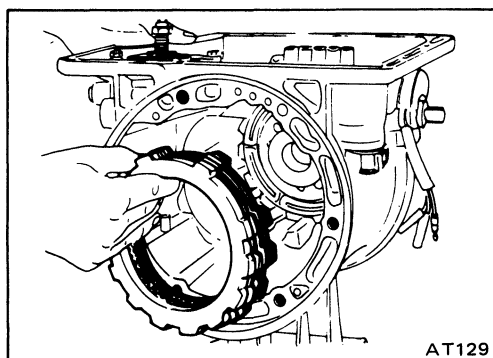

5. Install steel dished plate first, then steel and friction plates, and, finally, retaining plate and snap-ring.

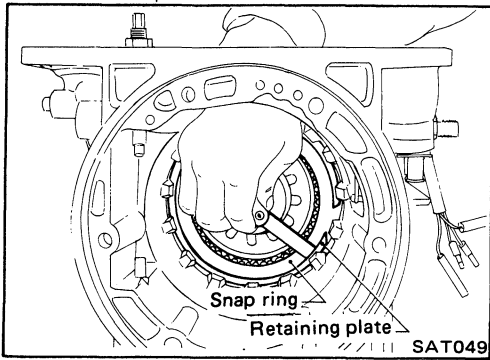

- After low and reverse brake has been completely assembled, measure clearance between snap ring and retainer plate. If measurement exceeds specifications adjust by replacing retainer plate with one of a different thickness.

Low and reverse brake clearance:

0.80 - 1.05 mm (0.0315 - 0.0413 in)

Available retainer plates: Refer to S.D.S.

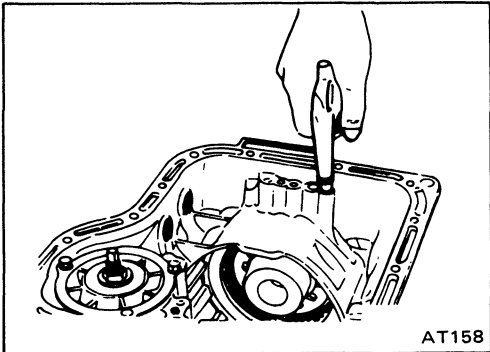

- Check low and reverse brake operation using compressed air.

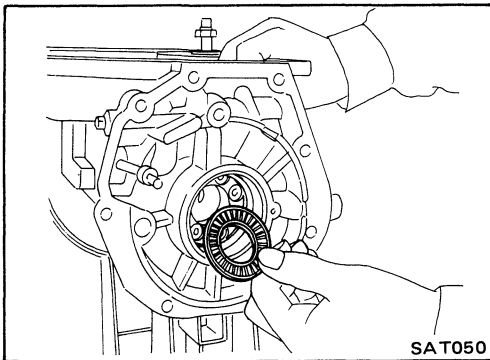

- Install governor needle bearing.

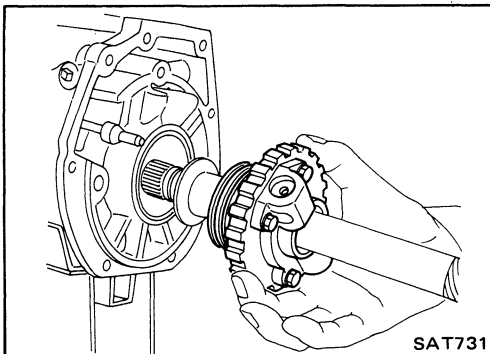

- Install thrust washer, output shaft and governor distributor into case.

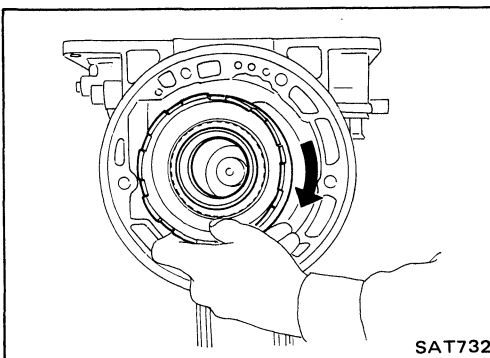

- Install connecting drum with sprag by rotating drum clockwise.

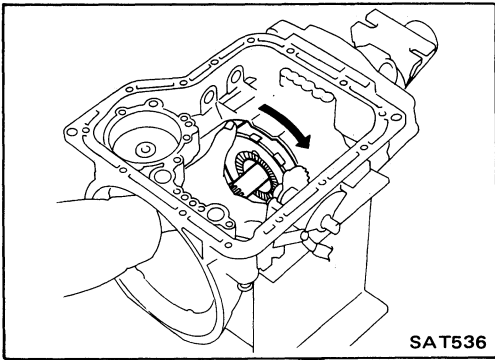

11. Check one-way clutch to see if it operates properly.

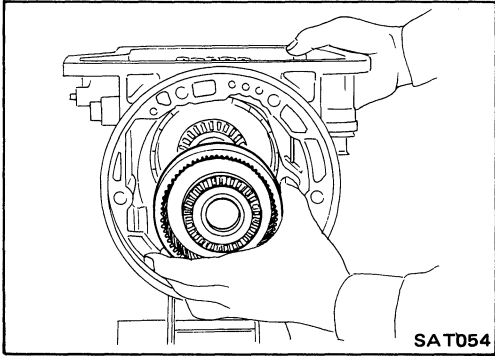

12. Install rear internal gear.

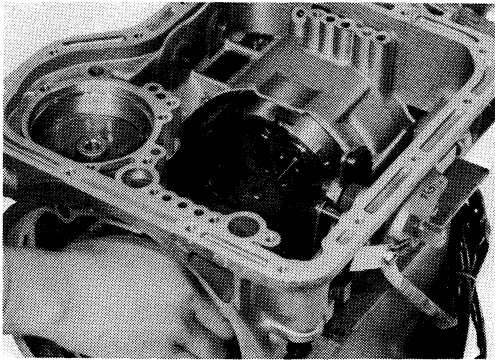

13. Install snap ring on shaft.

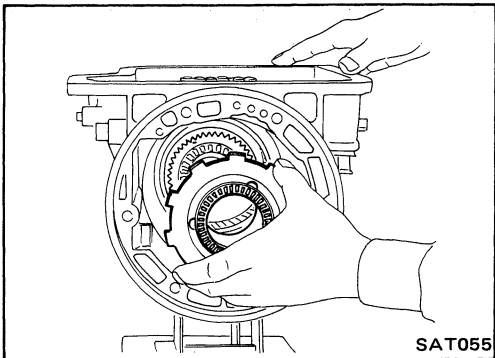

14. Secure thrust bearing and thrust washer with vaseline and install rear planetary carrier.

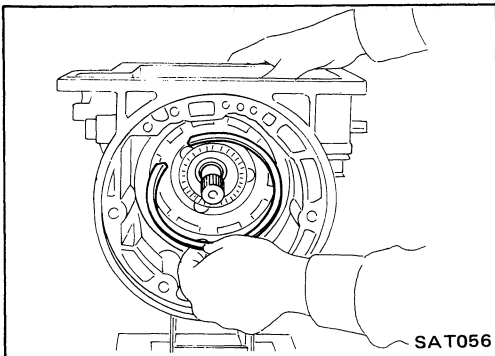

15. Install rear planetary carrier snap ring.
If you have insufficient space to install snap ring into drum groove, pull connecting drum forward as far as possible.

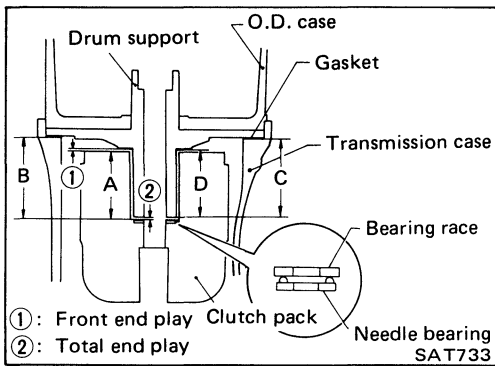

16. Adjust end play as follows:

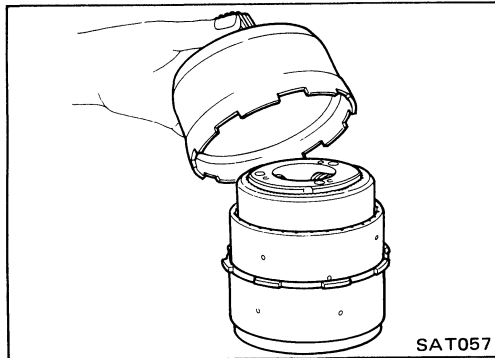

1) Assemble front internal gear, front planetary carrier and connecting shell. Secure thrust bearings with vaseline.

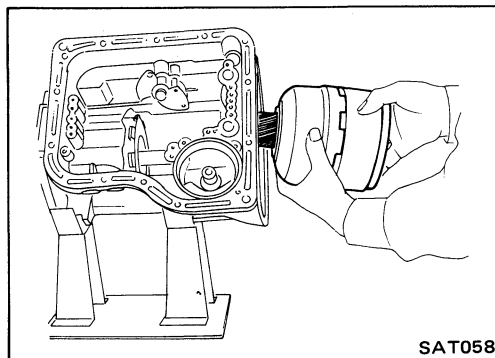

2) Install assembly into transmission case. Check that parts are properly seated before proceeding with measurements.

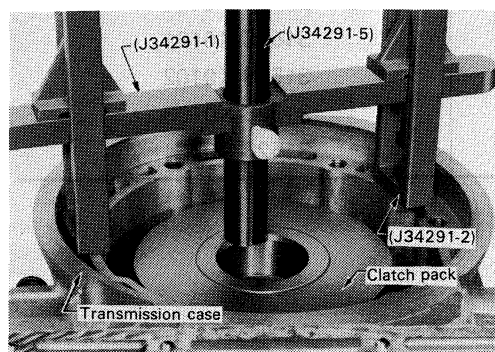

3) Adjust front end play.

a. Place J34291-1 (bridge), J34291-2 (legs) and J34291-5 (gauging cylinder) on machined surface of transmission case (no gasket): Position bridge legs so short end of legs is down, and adjust the legs to fit onto case properly. Allow the gauging cylinder to rest on top of thrust washer surface of clutch pack. Now lock gauging cylinder in position with thumbscrew.

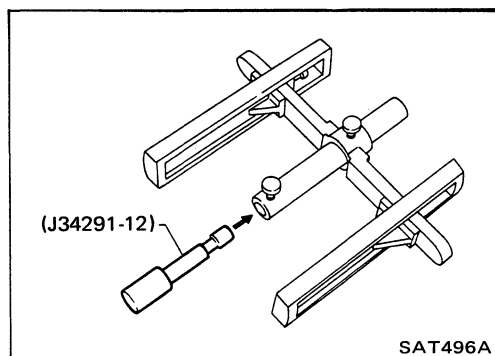

b. Remove thrust washer from drum support.

c. Now insert J34291-12 (gauging plunger) into gauging cylinder.

Lock gauging plunger by tightening the thumbscrew.

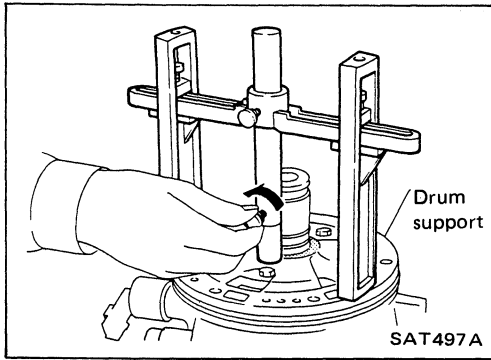

d. Place bridge, gauging cylinder and gauging plunger onto machined surface of the drum support. Loosen plunger set screw and allow plunger to drop onto drum support thrust washer surface. Now lock gauging cylinder in position with thumbscrew.

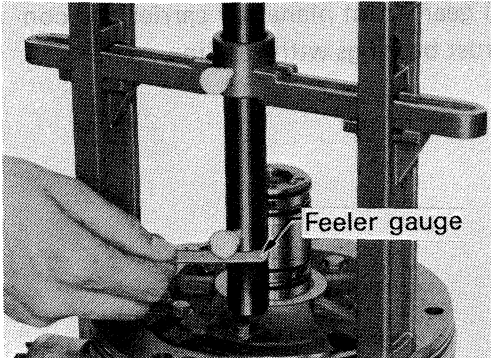

e. Use feeler gauge to measure gap between gauging cylinder and shoulder of the gauging plunger.

f. Use your feeler gauge measurement and the following thrust washer chart to select the correct washer thickness to give you proper total end play.

Available front clutch thrust washer

Thickness mm (in)	Part number
1.3 (0.051)	31528-X0107
1.5 (0.059)	31528-X0105
1.7 (0.067)	31528-X0106
1.9 (0.075)	31528-X0100
2.1 (0.083)	31528-X0101
2.3 (0.091)	31528-X0102
2.5 (0.098)	31528-X0103
2.7 (0.106)	31528-X0104

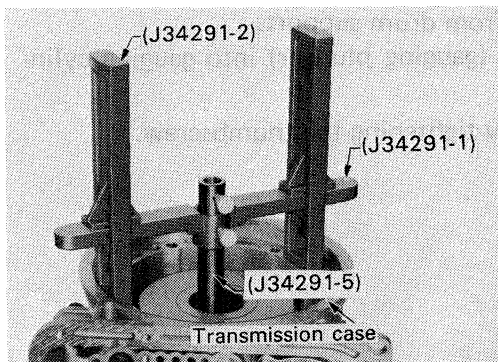

4) Adjust total end play.

a. Place J34291-1 (bridge), J34291-2 (legs) and J34291-5 (gauging cylinder) on machined surface of transmission case (no gasket). Position bridge legs so short end of legs is down, and adjust legs to fit onto case properly. Allow gauging cylinder to rest on top of needle bearings in forward clutch. Now lock gauging cylinder in position with thumbscrew.

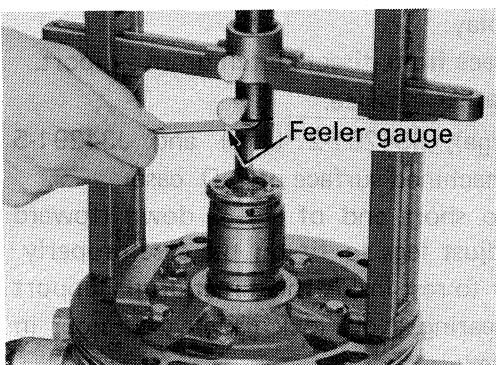
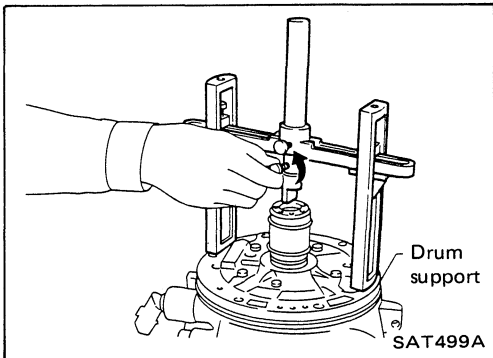
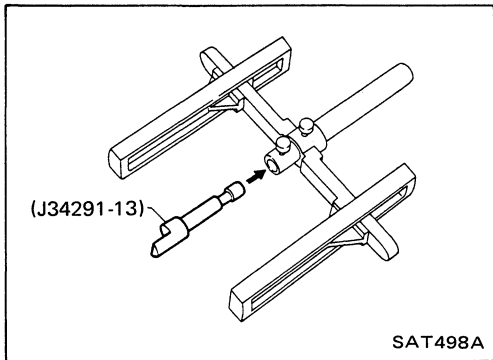
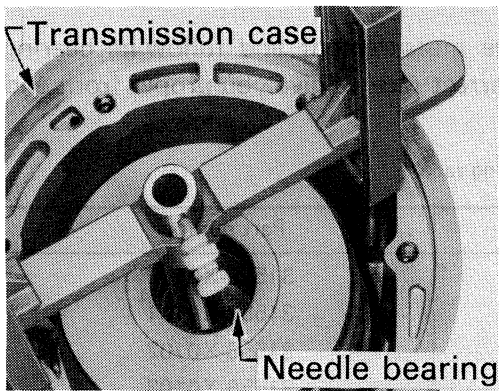

- b. Now insert J34291-13 (gauging plunger) into the gauging cylinder. Lock the gauging plunger by tightening thumb-screw.

- c. Remove oil pump cover bearing race from drum.
- d. Place bridge, gauging cylinder, and gauging plunger onto machined surface of drum support. Loosen plunger set screw and allow plunger to rest on top of drum support. Now lock plunger thumbscrew.

- e. Use feeler gauge to measure gap between gauging cylinder and shoulder of gauging plunger.

- f. Use your feeler gauge measurement and following bearing race chart to select correct race to give you proper front end play.

Available oil pump cover bearing race

Thickness mm (in)	Part number
1.2 (0.047)	31556-X0100
1.4 (0.055)	31556-X0101
1.6 (0.063)	31556-X0102
1.8 (0.071)	31556-X0103
2.0 (0.079)	31556-X0104
2.2 (0.087)	31556-X0105

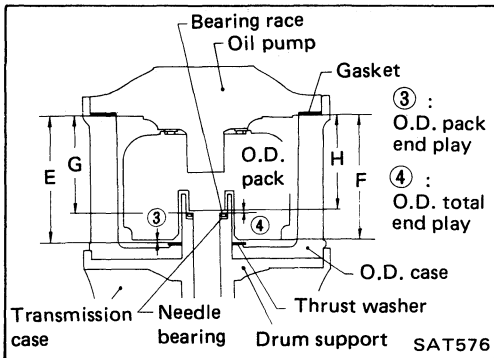

17. Adjust O.D. end play as follows:

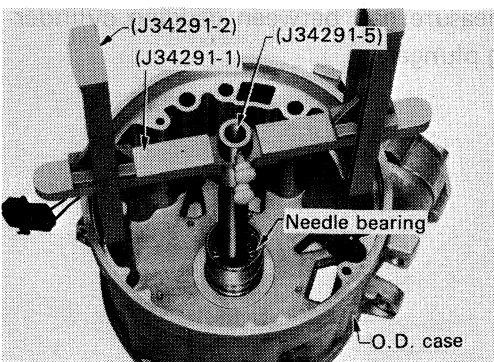

- 1) Adjust O.D. total end play.
 - a. Remove O.D. bearing race from direct clutch drum support. Leave needle thrust washer in place.
 - b. Place J34291-1 (bridge), J34291-2 (legs) and J34291-5 (gauging cylinder) on machined surface of O.D. case. Position bridge legs so short end of legs is down (toward drum support), and adjust legs to fit on the case properly. Allow gauging cylinder to rest inside the direct drum support onto top of needle bearing. Now lock gauging cylinder in position with thumbscrew.
 - c. Put oil pump bearing and O.D. planetary gear assembly on pump.

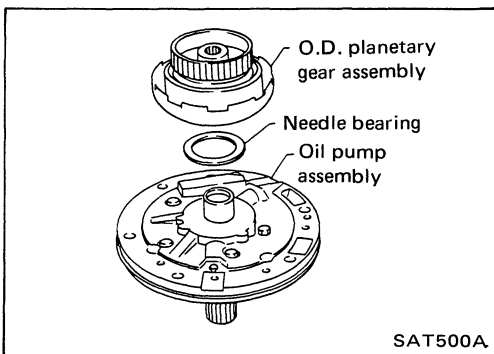

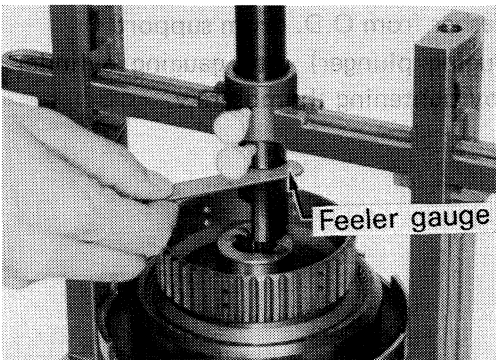
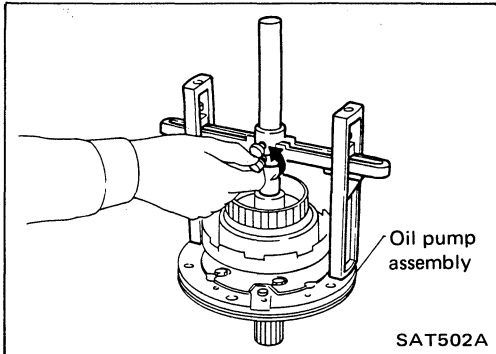
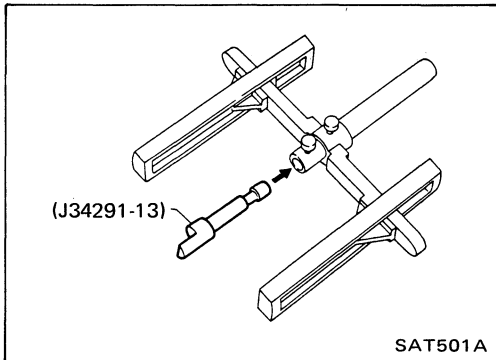

d. Now insert J34291-13 (gauging plunger) into gauging cylinder. Lock gauging plunger by tightening thumbscrew.

e. Place bridge, gauging cylinder, and gauging plunger on machined surface of oil pump. Loosen plunger setscrew and allow plunger to rest on bearing surface of O.D. internal gear. Now lock plunger in position the thumbscrew.

f. Use feeler gauge to measure gap between gauging cylinder and shoulder of gauging plunger.

g. Use your feeler gauge measurements and following O.D. bearing race chart to select correct race thickness to give you proper O.D. total end play.

Available O.D. bearing races

Thickness mm (in)	Part number
1.2 (0.047)	31603-X8600
1.4 (0.055)	31603-X8601
1.6 (0.063)	31603-X8602
1.8 (0.071)	31603-X8603
2.0 (0.079)	31603-X8604
2.2 (0.887)	31603-X8605

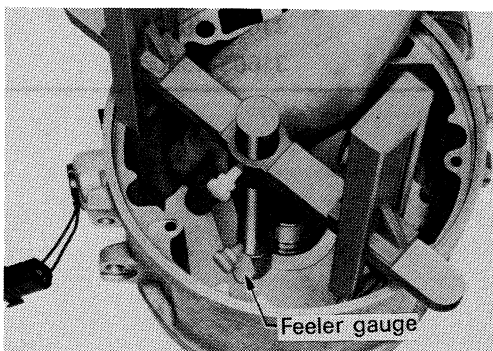
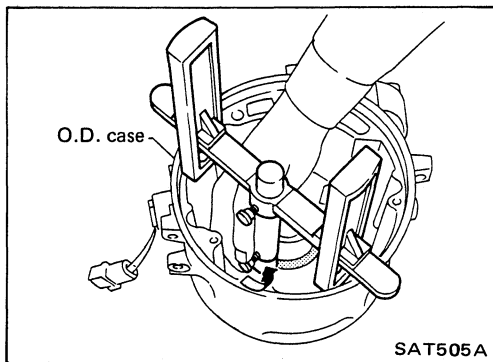
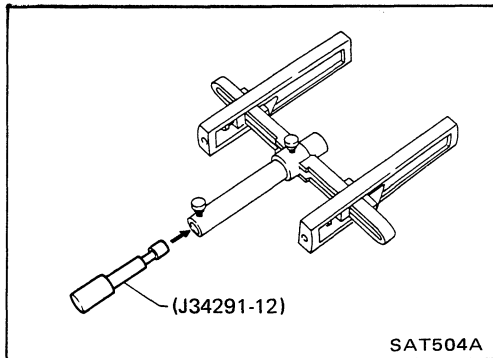
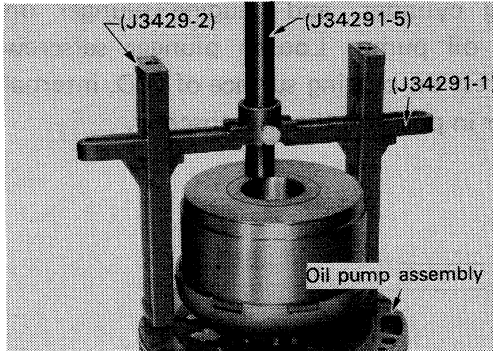
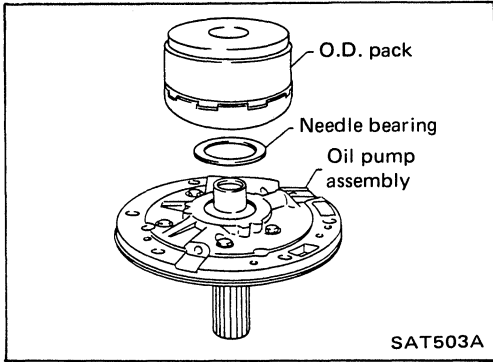

- 2) Adjust O.D. pack end play.
 - a. Put thrust needle bearing and O.D. pack on oil pump.

- b. Place J34291-1 (bridge), J34291-2 (legs) and J34291-5 (gauging cylinder) on machined surface of oil pump (no gasket). Position bridge legs so that long end of legs is down (to pump), and adjust legs to fit onto oil pump properly. Allow gauging cylinder to rest on top of thrust washer surface of O.D. pack. Now lock gauging cylinder in position with thumbscrew.

- c. Remove O.D. thrust washer from O.D. drum support.
 - d. Insert J34291-12 (gauging plunger) into gauging cylinder. Lock gauging plunger by tightening thumbscrew.

- e. Place the bridge, gauging cylinder, and gauging plunger onto machined surface of the O.D. case. Loosen plunger setscrew and allow plunger to rest on machined thrust washer surface in O.D. case. Now lock plunger thumbscrew.

- f. Use feeler gauge to measure gap between gauging cylinder and shoulder of gauging plunger.

- g. Use your feeler gauge measurement and the following thrust washer chart to select the correct washer thickness for proper total O.D. pack end play.

Available O.D. thrust washer

Thickness mm (in)	Part number
1.3 (0.051)	31528-X8607
1.5 (0.059)	31528-X8605
1.7 (0.067)	31528-X8606
1.9 (0.075)	31528-X8600
2.1 (0.083)	31528-X8601
2.3 (0.091)	31528-X8602
2.5 (0.098)	31528-X8603
2.7 (0.106)	31528-X8604

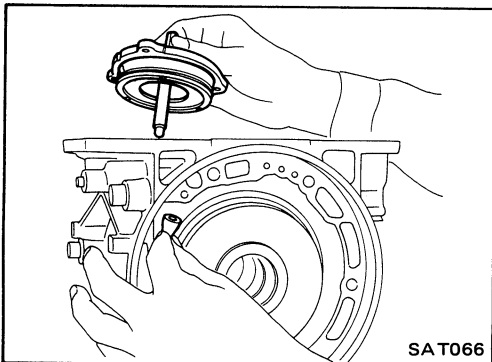

18. Install brake band, band strut, and band servo. Lubricate servo O-rings before installing.

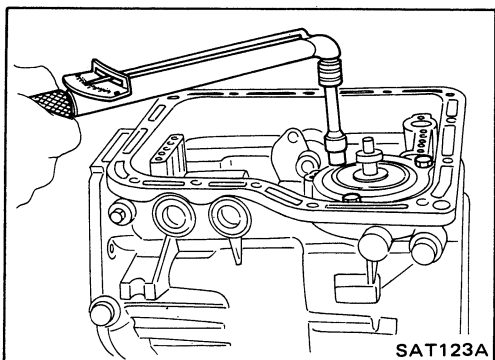

19. Install and tighten the retainer bolts. And then loosen piston stem.

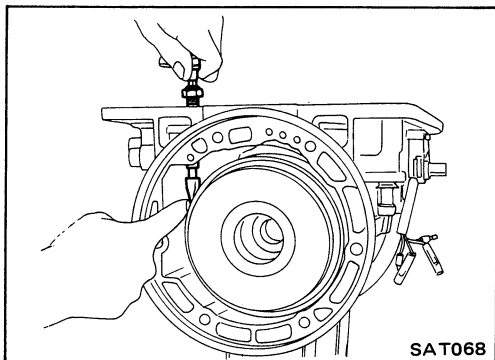

20. Tighten piston stem of brake band servo with finger enough to prevent brake band and strut from falling out. Do not adjust brake band at this time.

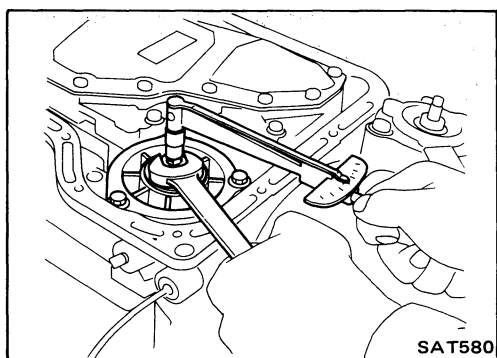
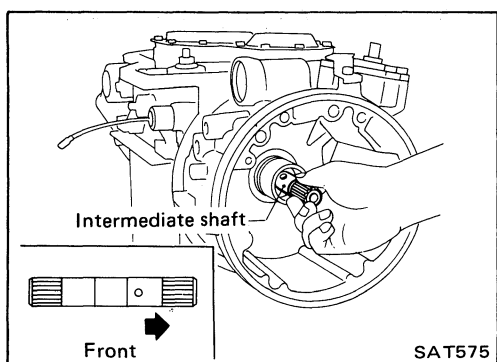
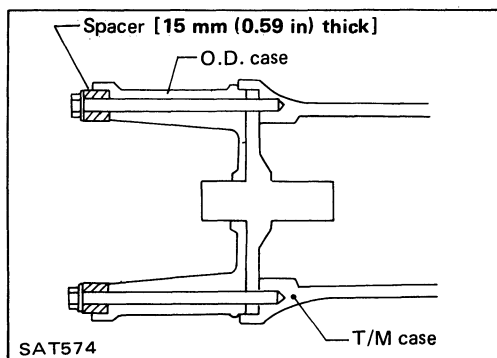
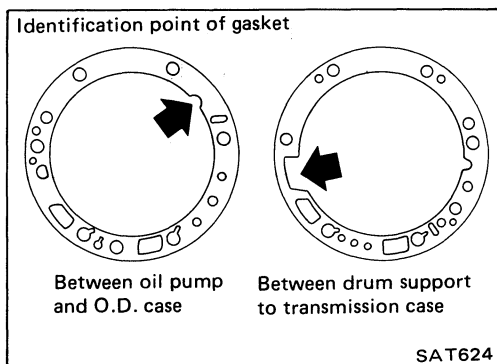
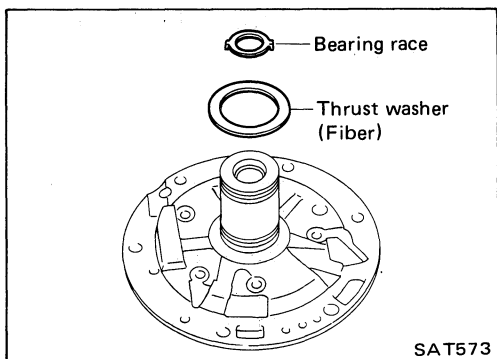

21. Apply vaseline to bearing race and thrust washer, then mount them on drum support.

22. Mount drum support on transmission case after coating with vaseline. Apply A.T.F. to O-ring of drum support. Align oil pump with O.D. case to transmission case and install.

23. Apply A.T.F. to O-ring of drum support, then install drum support and O.D. case.

Before installing drum support and O.D. case on transmission case, ensure that they have been centered properly. Refer to Component Parts for Drum Support.

24. Temporarily tighten O.D. case with two converter housing securing bolts.

25. Insert intermediate shaft.
Be careful of shaft direction.

26. Adjust 2nd brake band. Tighten piston stem to the specified value. Back off three full turns and secure with lock nut.

- ☞ : 2nd brake band piston stem
12 - 15 N·m (1.2 - 1.5 kg·m, 9 - 11 ft·lb)
- Lock nut
15 - 39 N·m (1.5 - 4.0 kg·m, 11 - 29 ft·lb)

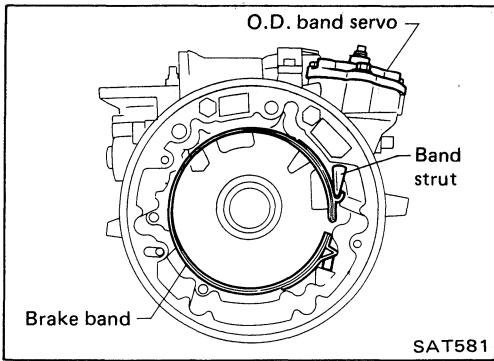

27. Lubricate O.D. servo O-rings, then install O.D. band servo, brake band and band strut.

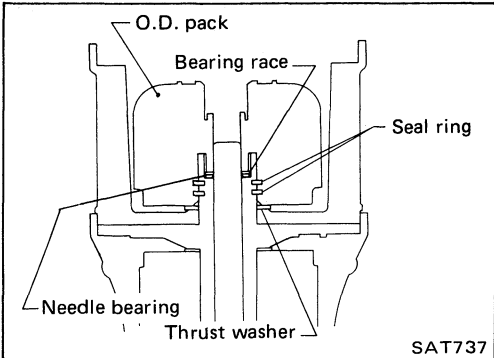

28. Lubricate seal ring of drum support, then install O.D. bearing & race, O.D. thrust washer and O.D. pack on drum support. Make sure that brake band strut is correctly installed.

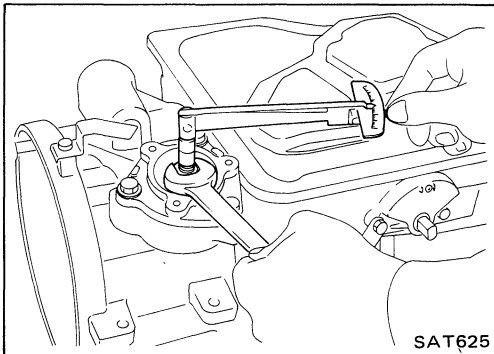

29. Adjust O.D. band. Tighten piston stem to the specified value. Back off two full turns and secure with lock nut.

- ☞ : O.D. band piston stem
7 - 10 N·m (0.7 - 1.0 kg-m, 5.1 - 7.2 ft-lb)
- Lock nut
15 - 39 N·m (1.5 - 4.0 kg-m, 11 - 29 ft-lb)

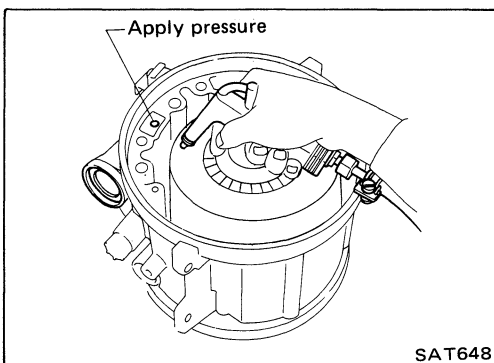

30. Test O.D. band servo operation using compressed air.

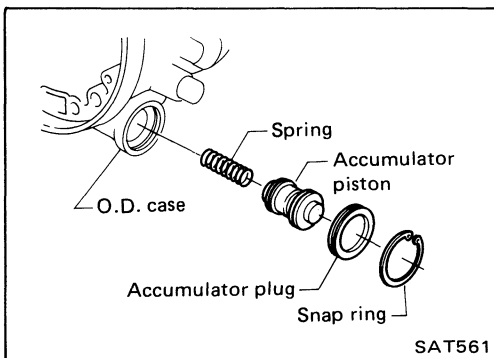

31. Install accumulator parts, then secure with snap ring.

32. Lubricate O-ring of oil pump, then install needle bearing & race and oil pump.

Before installing oil pump housing and oil pump on O.D. case, ensure that they have been centered properly.

Refer to Oil Pump in Repair for Component parts.

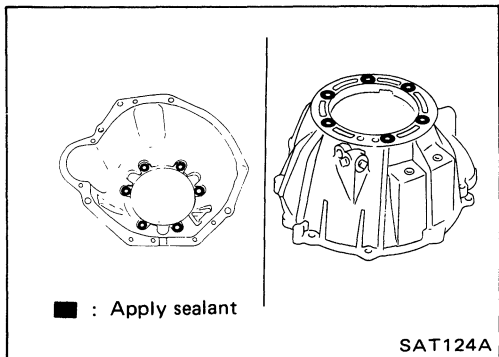

33. Remove the two bolts used to temporarily tighten O.D. case. Apply sealant to seating surface of converter housing around the bolt holes.

34. Install converter housing on O.D. case and tighten to the specified torque.

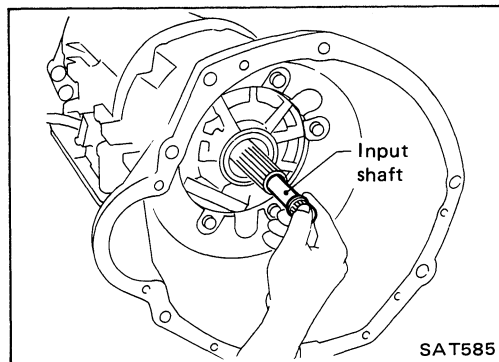

35. Install input shaft.

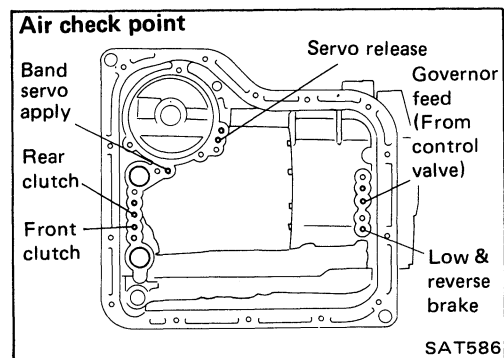

36. Before installing valve body assembly perform a final operation check of all assembled components, using compressed air.

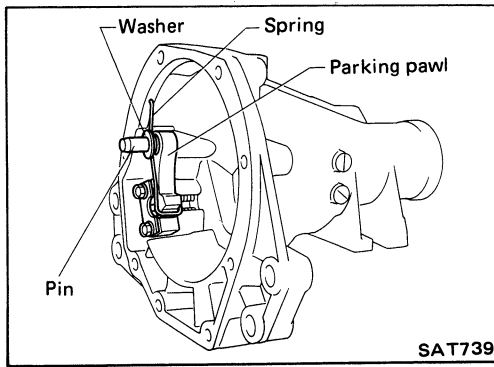

37. Check that parking pawl, pin, spring and washer are assembled correctly.
38. Install rear extension (adapter case).

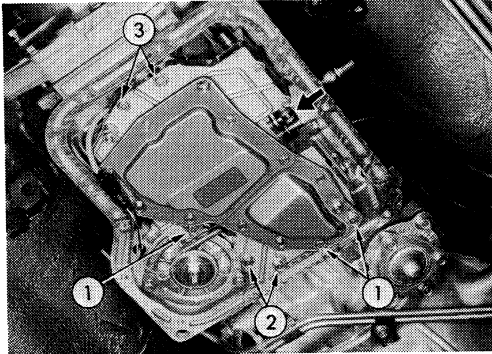

39. Install control valve assembly. Be sure manual valve is in alignment with selector pin. Tighten control valve body attaching bolts.

Securing bolt comes in three different lengths.

After installing control valve to transmission case, make sure that control lever can be moved to all positions.

- Bolt length:**
 1 40 mm (1.57 in)
 2 35 mm (1.38 in)
 3 25 mm (0.98 in)

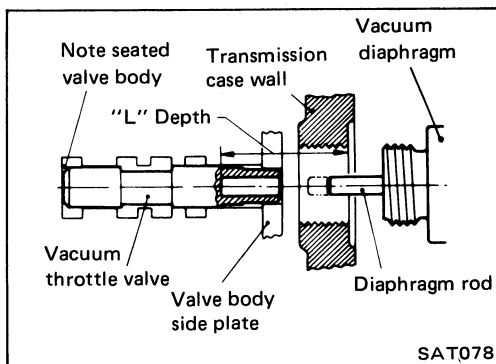

40. Before installing vacuum diaphragm valve, measure depth of hole in which it is inserted. This measurement determines correct rod length to ensure proper performance.

Vacuum diaphragm rod selection

Measured depth "L" mm (in)	Rod length mm (in)	Part number
Under 25.55 (1.0059)	29.0 (1.142)	31932-X0103
25.65 - 26.05 (1.0098 - 1.0256)	29.5 (1.161)	31932-X0104
26.15 - 26.55 (1.0295 - 1.0453)	30.0 (1.181)	31932-X0100
26.65 - 27.05 (1.0492 - 1.0650)	30.5 (1.201)	31932-X0102
Over 27.15 (1.0689)	31.0 (1.220)	31932-X0101

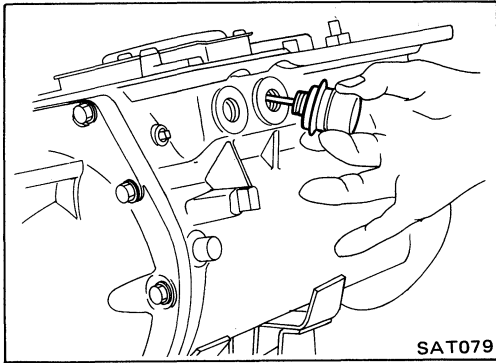

41. Install vacuum diaphragm.

Make sure that vacuum diaphragm rod does not interfere with side plate of control valve.

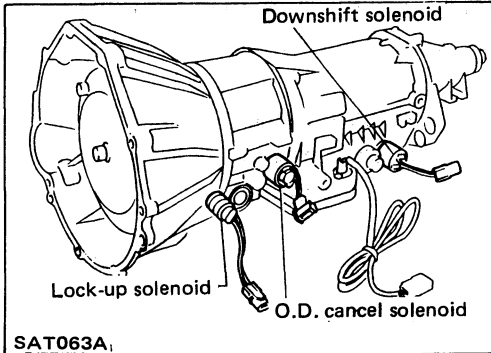

42. Install downshift solenoid, O.D. cancel solenoid and lock-up solenoid.

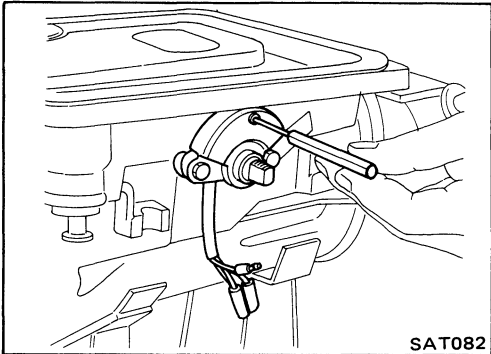

43. Install inhibitor switch. Check for proper operation in each range with a circuit tester. Refer to On-vehicle Service.

44. Before installing oil pan, check parking pawl engagement.

45. Install oil pan with new gasket.

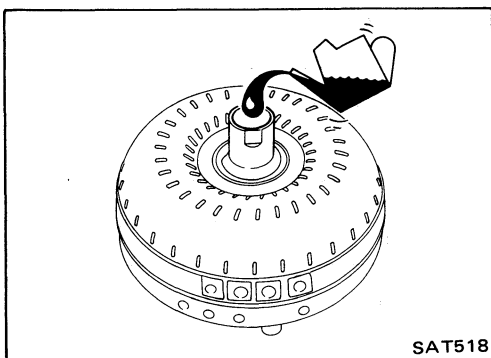

46. Pour approx. 2-liters (2-1/8 US qt, 1-3/4 Imp qt) of A.T.F. into converter housing.

47. Install torque converter to converter housing.

Be careful not to scratch front oil seal.

Service Notice

- Before proceeding with disassembly, thoroughly clean the outside of the transmission. It is important to prevent the internal parts from becoming contaminated by dirt or other foreign matter.
- Disassembly should be done in a clean work area.
- Use lint-free cloth or towels for wiping parts clean. Common shop rags can leave fibers that could interfere with the operation of the transmission.
- When disassembling parts, place them in order in a parts rack so that they can be put back into the unit in their proper positions.
- All parts should be carefully cleaned with a general purpose, non-flammable solvent before inspection or reassembly.
- Gaskets, seals and O-rings should be replaced any time the transmission is disassembled.
- It is very important to perform functional tests whenever they are indicated.
- The valve body contains precision parts and requires extreme care when parts are removed and serviced. Place removed parts in order on a parts rack so they can be put back in the valve body in the same positions and sequences. Care will also prevent springs and small parts from becoming scattered or lost.
- Properly installed valves, sleeves, plugs, etc. will slide along their bores in the valve body under their own weight.
- Before assembly, apply a coat of recommended A.T.F. to all parts. Petroleum jelly may be applied to O-rings and seals and used to hold small bearings and washers in place during re-assembly. Do not use grease.
- Extreme care should be taken to avoid damage to O-rings, seals and gaskets when assembling.
- After overhaul, refill the transmission with new A.T.F.

Abbreviations and Symbols

- A.T.F. Automatic Transmission Fluid
- D₁ Drive range 1st gear
- D₂ Drive range 2nd gear
- D₃ Drive range 3rd gear
- D₄ Drive range 4th gear
- O.D. Overdrive
- 2₂ 2nd range 2nd gear
- 2₁ 2nd range 1st gear
- 1₂ 1st range 2nd gear
- 1₁ 1st range 1st gear

 : Apply recommended sealant (Nissan genuine part: KP610-00250) or equivalent.

 (P) : Apply petroleum jelly.

 : Apply A.T.F.

★ : Select with proper thickness.

☆ : Adjustment is required.

 : Check after disconnecting the connector to be measured.

 : Check after connecting the connector to be measured.

 : Turn ignition switch to "ON" position.

 : Turn ignition switch to "OFF" position.

 : Turn ignition switch to "START" position.

 : Do not start engine.

 : Start engine.

 : Apply parking brake.

 : Release parking brake.

 : Drive vehicle.

Hydraulic Control Circuits

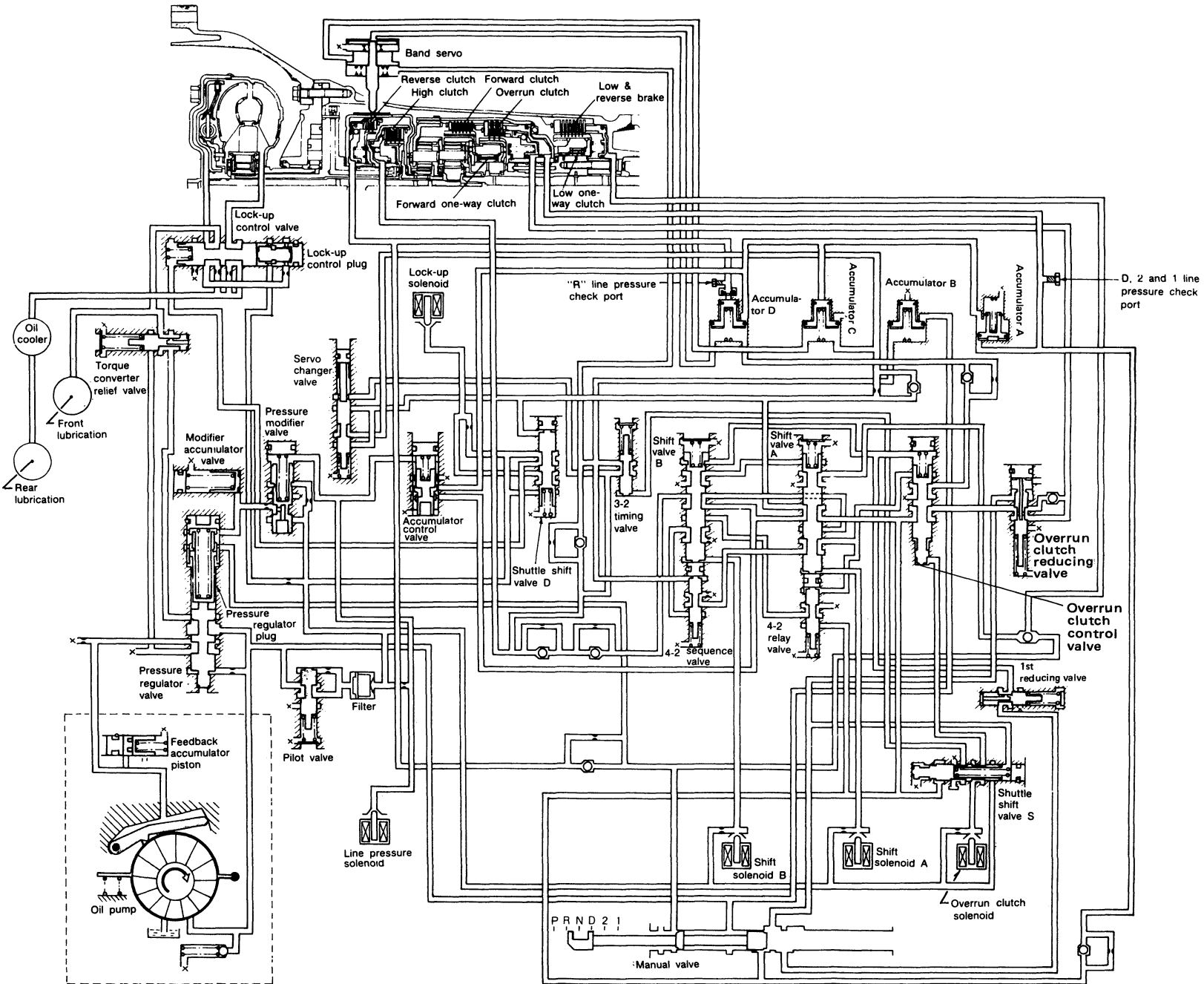

AT-126

SAT123B

Electrical Control Chart

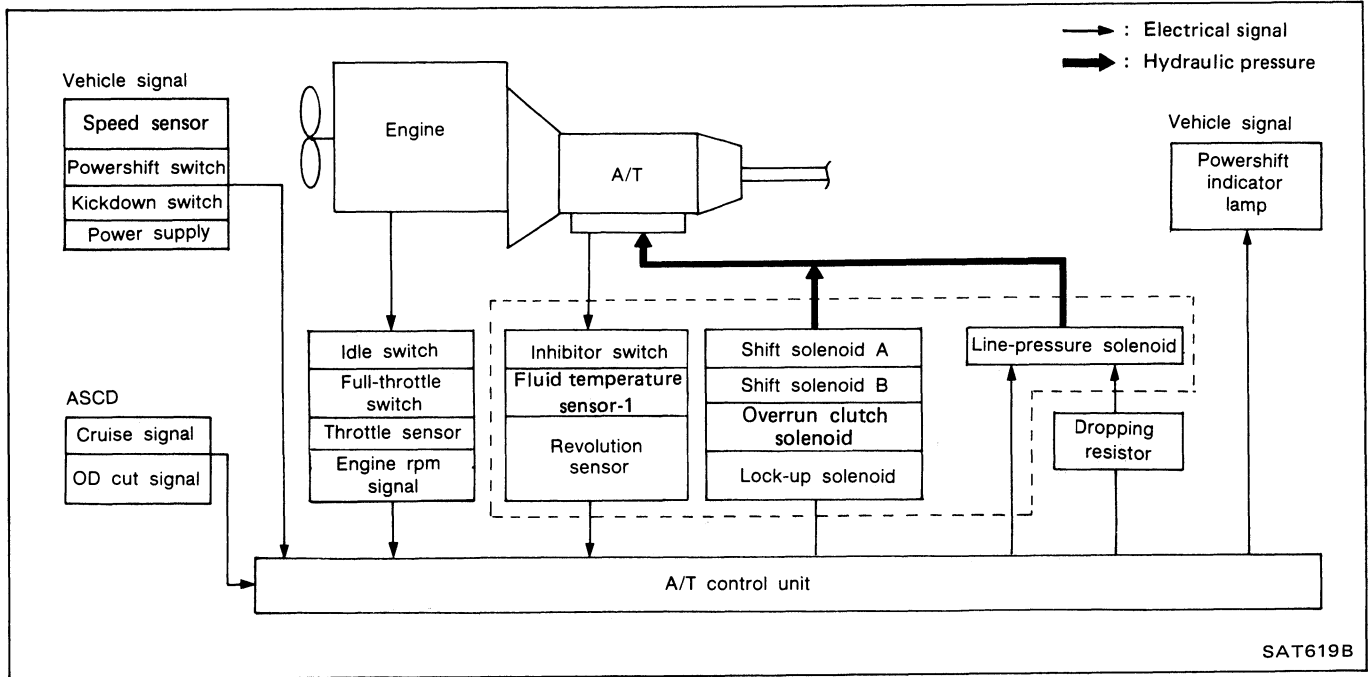

SAT619B

Mechanical Operation

Shift position	Reverse clutch	High clutch	Forward clutch	Overrun clutch	Band servo			Forward one-way clutch	Low one-way clutch	Low & reverse brake	Lock-up	Remarks
					2nd apply	3rd release	4th apply					
P												PARK
R	○									○		REVERSE
N												NEUTRAL
D *4	1st		○	⊗				●	●			Automatic shift 1 ↔ 2 ↔ 3 ↔ 4
	2nd		○	⊗ ^{*1}	○			●				
	3rd		○	○	⊗	*2⊗	⊗	●				
	4th		○	⊗		*3⊗	⊗	○			○	
2	1st		○	⊗				●	●			Automatic shift 1 ↔ 2
	2nd		○	⊗	○			●				
1	1st		○	○				●		○		Locks (held stationary) in 1st speed 1 ← 2
	2nd		○	○	○			●				

*1. Operates when power shift switch is set to "POWER".

*2. Oil pressure is applied to both 2nd "apply" side and 3rd "release" side of band servo piston. However, because oil pressure area on the "release" side is greater than that on the "apply" side, brake band does not contract.

*3. Oil pressure is applied to 4th "apply" side in condition *2 above, and brake band contracts.

*4. A/T will not shift to 4th when power shift switch is set to "POWER" position.

○ : Operates.

⊗ : Operates when throttle opening is less than 1/16. Engine brake activates.

● : Operates during "progressive" acceleration.

⊗ : Operates but does not affect power transmission.

⊗ : Operates when throttle opening is less than 1/16 but does not affect engine brake.

A/T CONTROL DIAGRAM

REAR01A

Cross-Sectional View

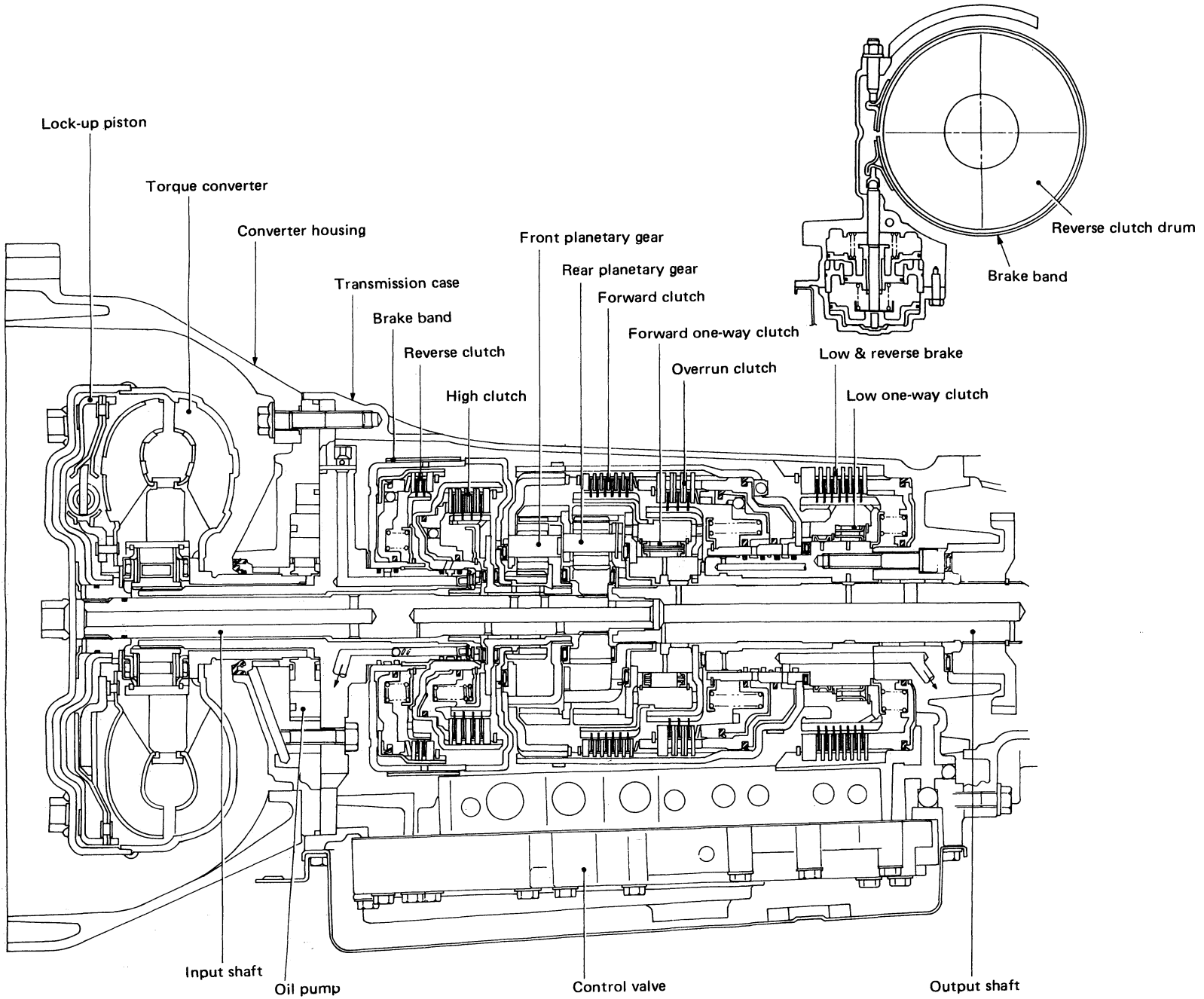

AT-128

SATT125B

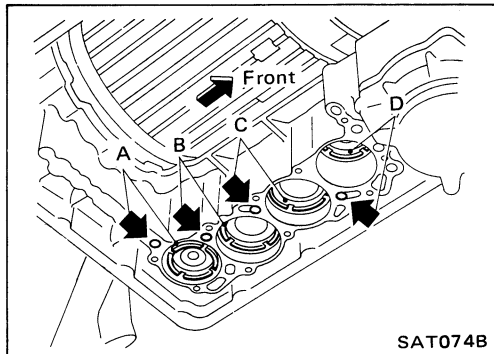
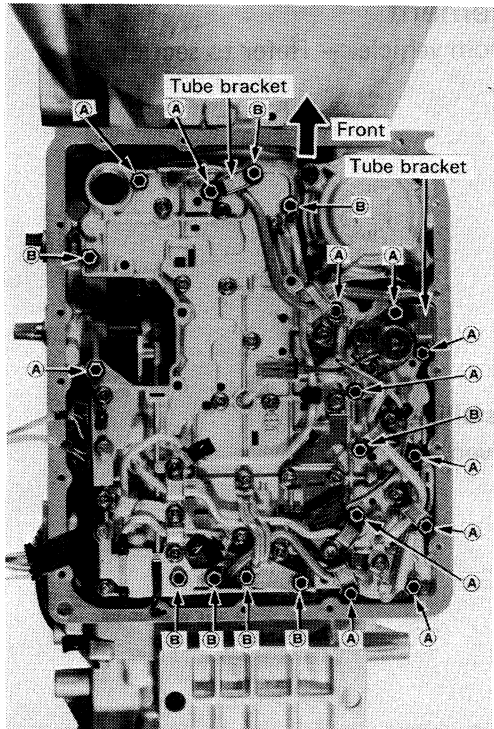
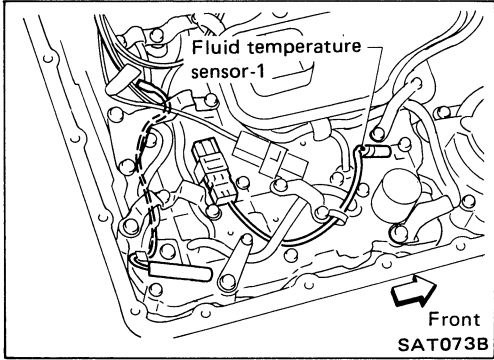
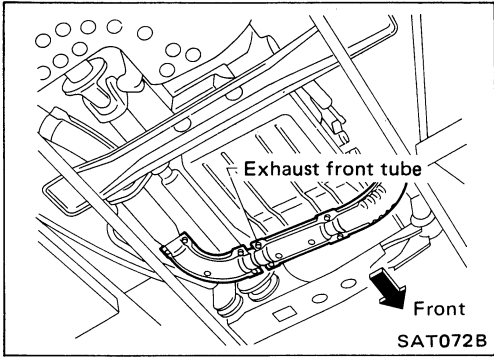

Control Valve Assembly and Accumulators Inspection

1. Remove exhaust front tube.
2. Remove oil pan and gasket and drain A.T.F.
3. Remove fluid temperature sensor-1 if necessary.
4. Remove oil strainer.
5. Remove control valve assembly by removing fixing bolts and disconnecting harness connector.

Bolt length and location

Bolt symbol	Length mm (in)
A	37 (1.46)
B	50 (1.97)

6. Remove solenoids and valves from valve body if necessary.
7. Remove terminal cord assembly if necessary.
8. Remove accumulator A, B, C and D by applying compressed air if necessary.
 - Hold each piston with rag.
9. Reinstall any part removed.
 - Always use new sealing parts.

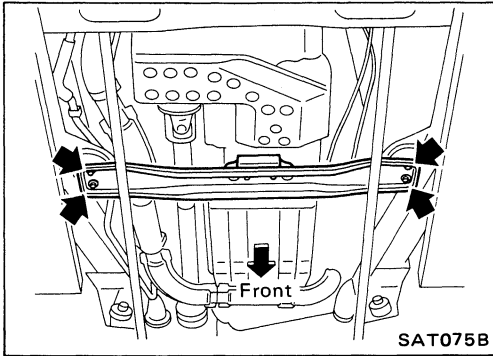

Revolution Sensor Replacement

1. Remove rear engine mounting member from side member while supporting A/T with transfer case with jack.
2. Lower A/T with transfer case as much as possible.

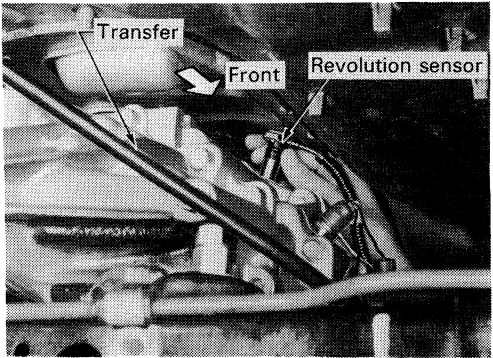

3. Remove revolution sensor from A/T.
 4. Reinstall any part removed.
- Always use new sealing parts.

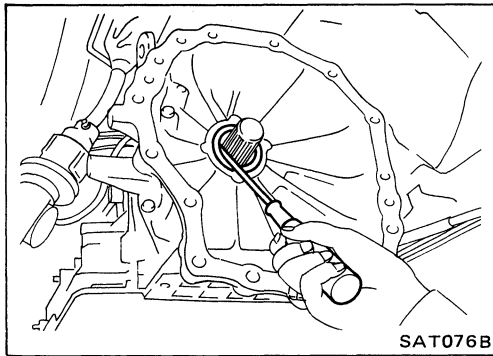

Rear Oil Seal Replacement

1. Remove transfer case from vehicle. — Refer to section TF.
2. Remove rear oil seal.

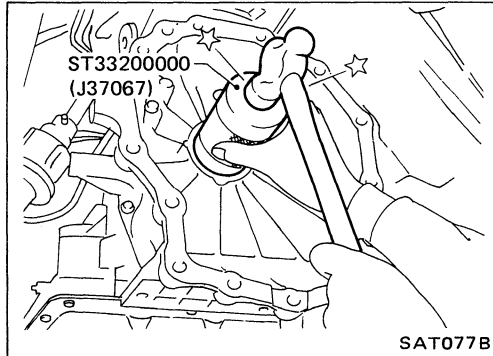

3. Install rear oil seal.
- Apply A.T.F. before installing.
4. Reinstall any part removed.

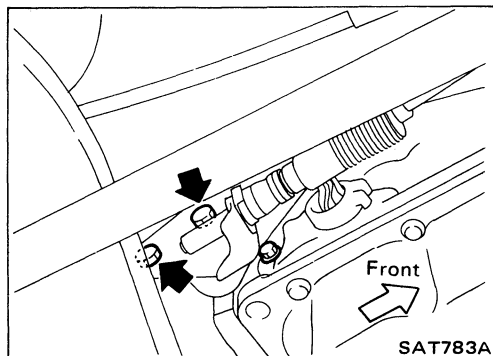

Parking Components Inspection

1. Remove transfer case from vehicle. — Refer to section TF.
2. Remove manual control linkage bracket from adapter case.

Parking Components Inspection (Cont'd)

3. Remove adapter case from transmission case.
 4. Replace parking components if necessary.
 5. Reinstall any part removed.
- Always use new sealing parts.

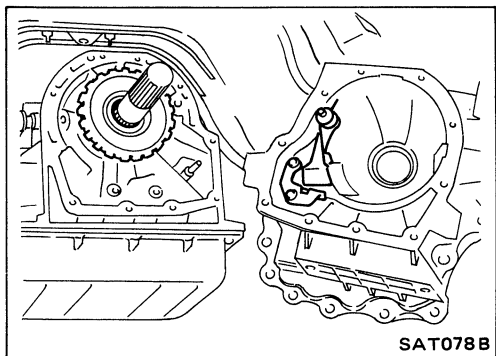

Inhibitor Switch Adjustment

1. Remove manual control linkage from manual shaft of A/T assembly.
2. Set manual shaft of A/T assembly in "N" position.
3. Loosen inhibitor switch fixing bolts.

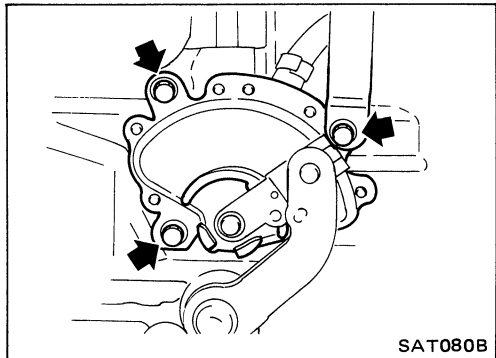

4. Insert pin into adjustment holes in both inhibitor switch and manual shaft of A/T assembly as near vertical as possible.
5. Reinstall any part removed.
6. Check continuity of inhibitor switch. — Refer to "Electrical System".

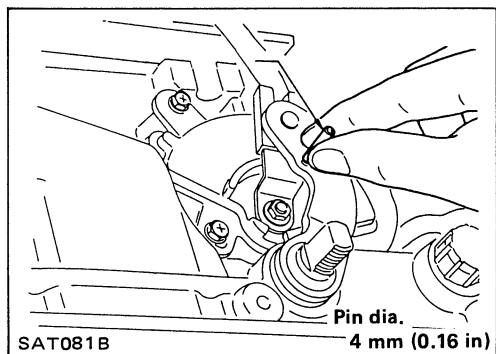

Manual Control Linkage Adjustment

Move selector lever from "P" range to "1" range. You should be able to feel the detents in each range.

If the detents cannot be felt or the pointer indicating the range is improperly aligned, the linkage needs adjustment.

1. Place selector lever in "P" range.
2. Loosen lock nuts.

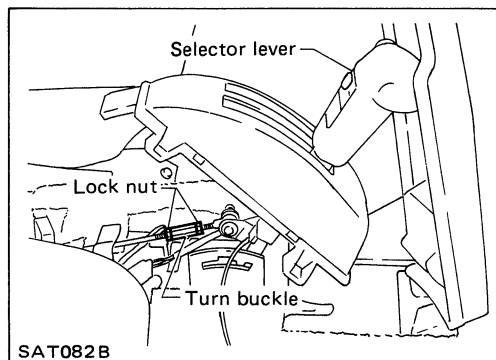

3. Tighten turn buckle until aligns with inner cable, pulling selector lever toward "R" range side without pushing button.
4. Back off turn buckle 1 turn and tighten lock nuts to the specified torque.

 : Lock nut
4.4 - 5.9 N·m
(0.45 - 0.60 kg-m, 3.3 - 4.3 ft-lb)

5. Move selector lever from "P" range to "1" range. Make sure that selector lever can move smoothly.

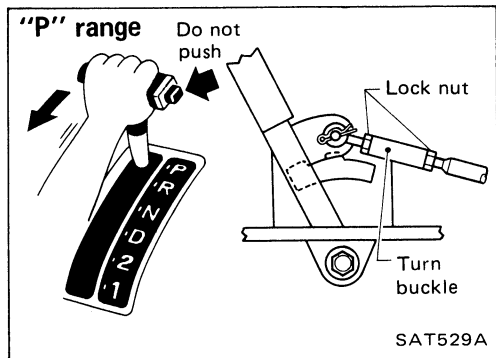

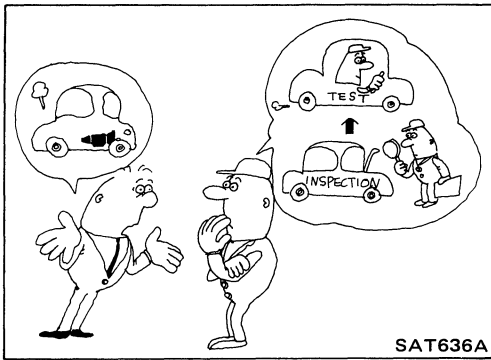

SAT636A

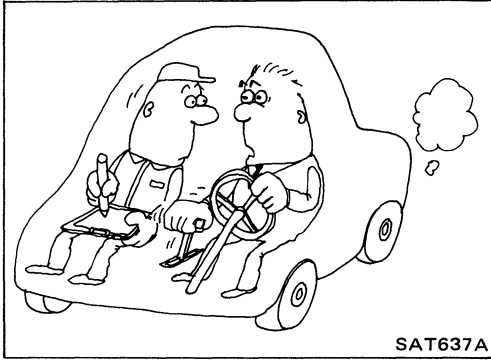

SAT637A



SAT638A

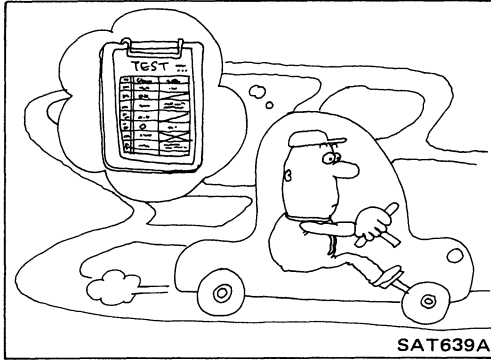

SAT639A

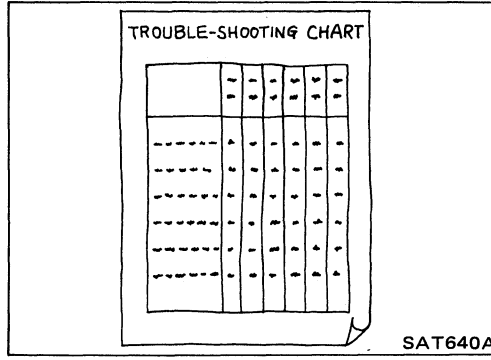

SAT640A

Diagnostic Procedure

1. Listen to customer's complaint attentively.
 - In most cases, problems related to A/T can be corrected with simple adjustments or repairs. Therefore, be careful not to remove or disassemble A/T prematurely.

- You should drive customer's vehicle with customer as a passenger in order to personally experience the problem.

2. Check A/T fluid level and condition. — Refer to A/T FLUID LEVEL CHECK in section MA and following A/T FLUID CHECK section.

3. Perform road test including A/T self-diagnosis and diagnose causes of A/T problem. — Refer to following ROAD TESTING section.

4. If problem is not found during road test, perform general inspection by following TROUBLE-SHOOTING CHART in response to driveability trouble items.

Diagnostic Procedure (Cont'd)

5. Repair or replace the necessary parts.

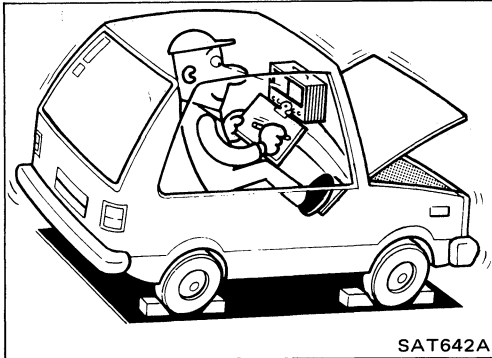
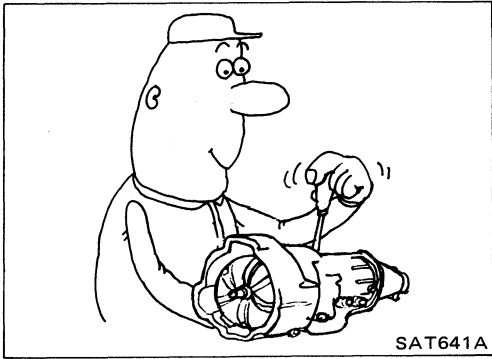

- 6. Perform stall test as a final check. — Refer to following STALL TESTING section.
- 7. Perform line pressure test as a final check. — Refer to following PRESSURE TESTING section.
- 8. Perform road test as a final check. — Refer to following ROAD TESTING section.

A/T Fluid Check

FLUID LEAKAGE CHECK

- 1. Clean area suspected of leaking, — for example, mating surface of converter housing and transmission case.
- 2. Start engine, apply foot brake, place selector lever in "D" range and wait a few minutes.
- 3. Stop engine.

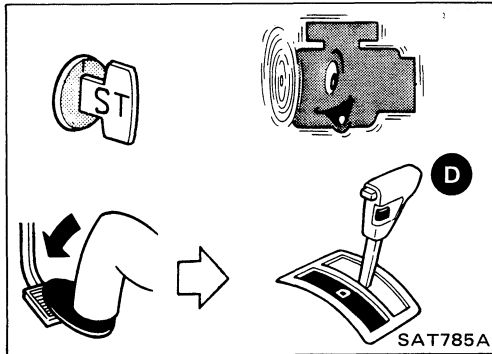

4. Check for fresh leakage.

FLUID CONDITION CHECK

Fluid color	Suspected problem
Dark or black with burned odor	Wear of frictional material
Milky pink	Water contamination — Road water entering through filler tube or breather
Varnished fluid, light to dark brown and tacky	Oxidation — Over or under filling — Overheating

FLUID LEVEL CHECK — Refer to section MA.

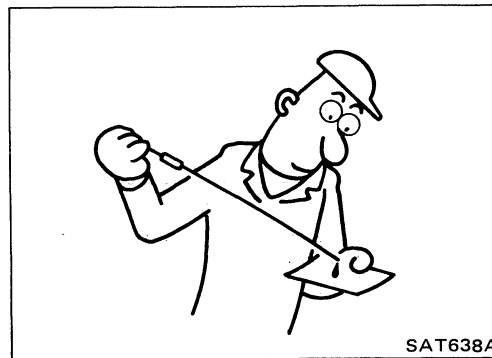
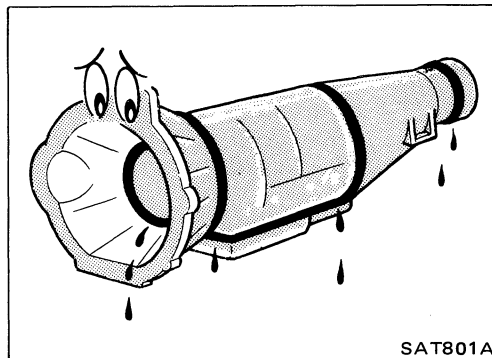

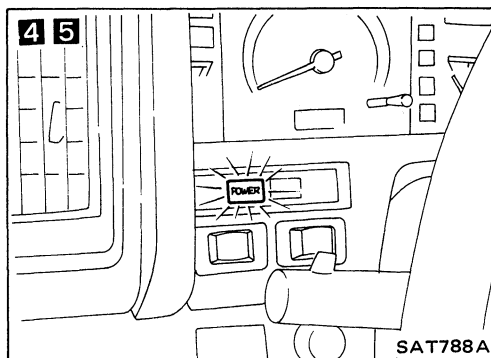
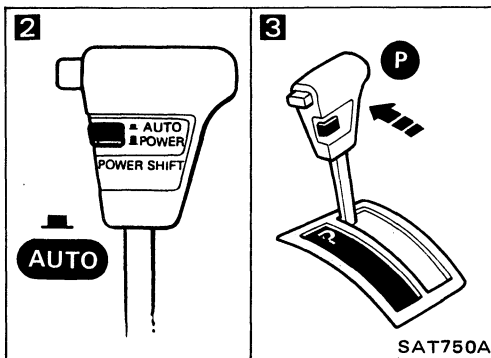
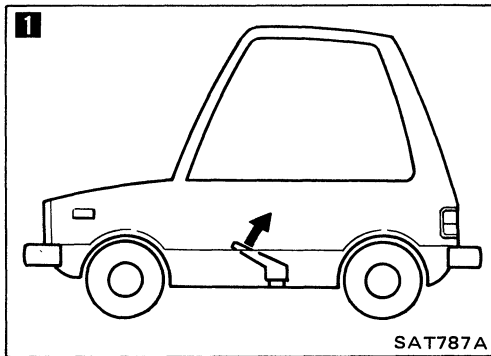
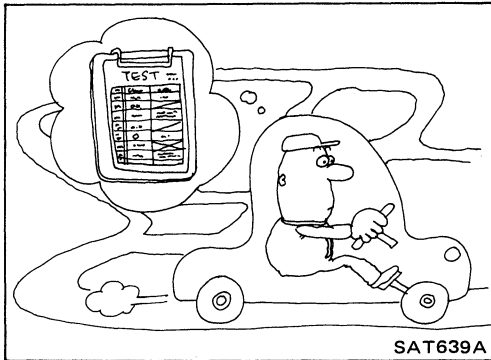
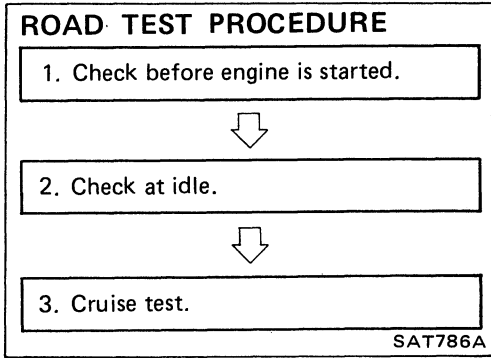

Road Testing DESCRIPTION

- The purpose of this road test is to determine overall performance of automatic transmission and analyze causes of problems.
- The road test consists of the following three parts:
 1. Check before engine is started
 2. Check at idle
 3. Cruise test
- Before road test, familiarize yourself with all test procedures and items to check.
- Conduct tests on all items. Troubleshoot items which check out No Good after road test. Refer to the "Troubleshooting".

1. CHECK BEFORE ENGINE IS STARTED

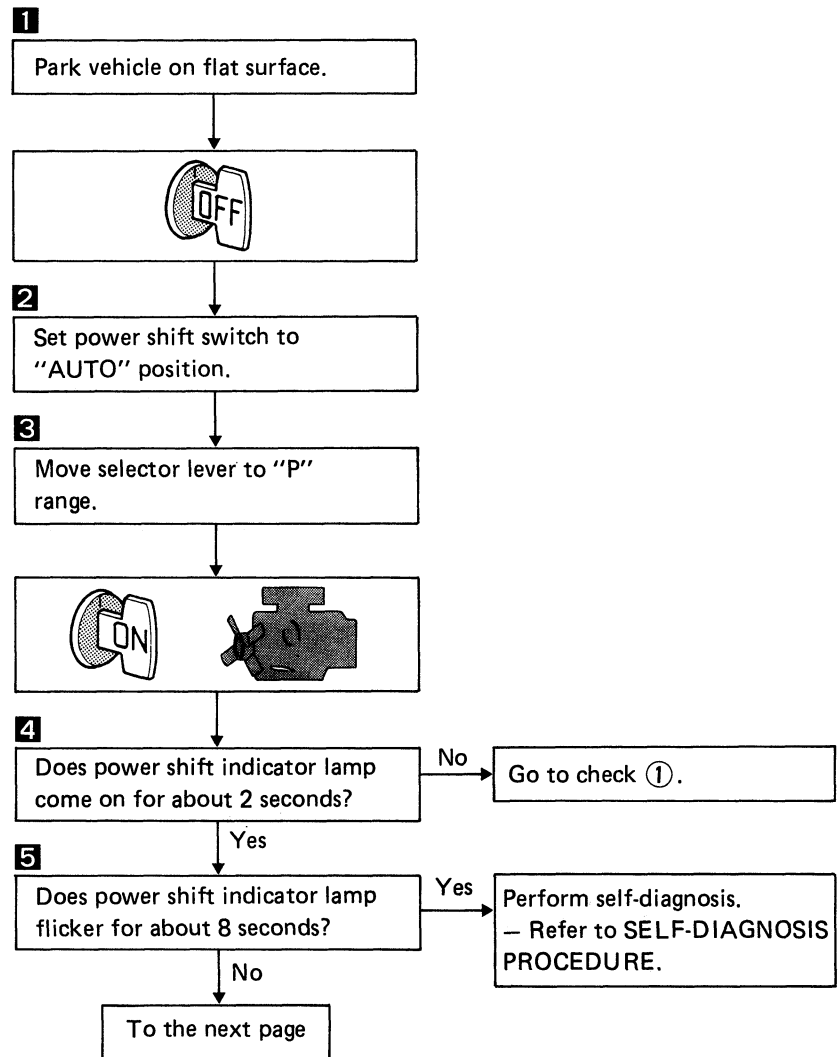

Road Testing (Cont'd)

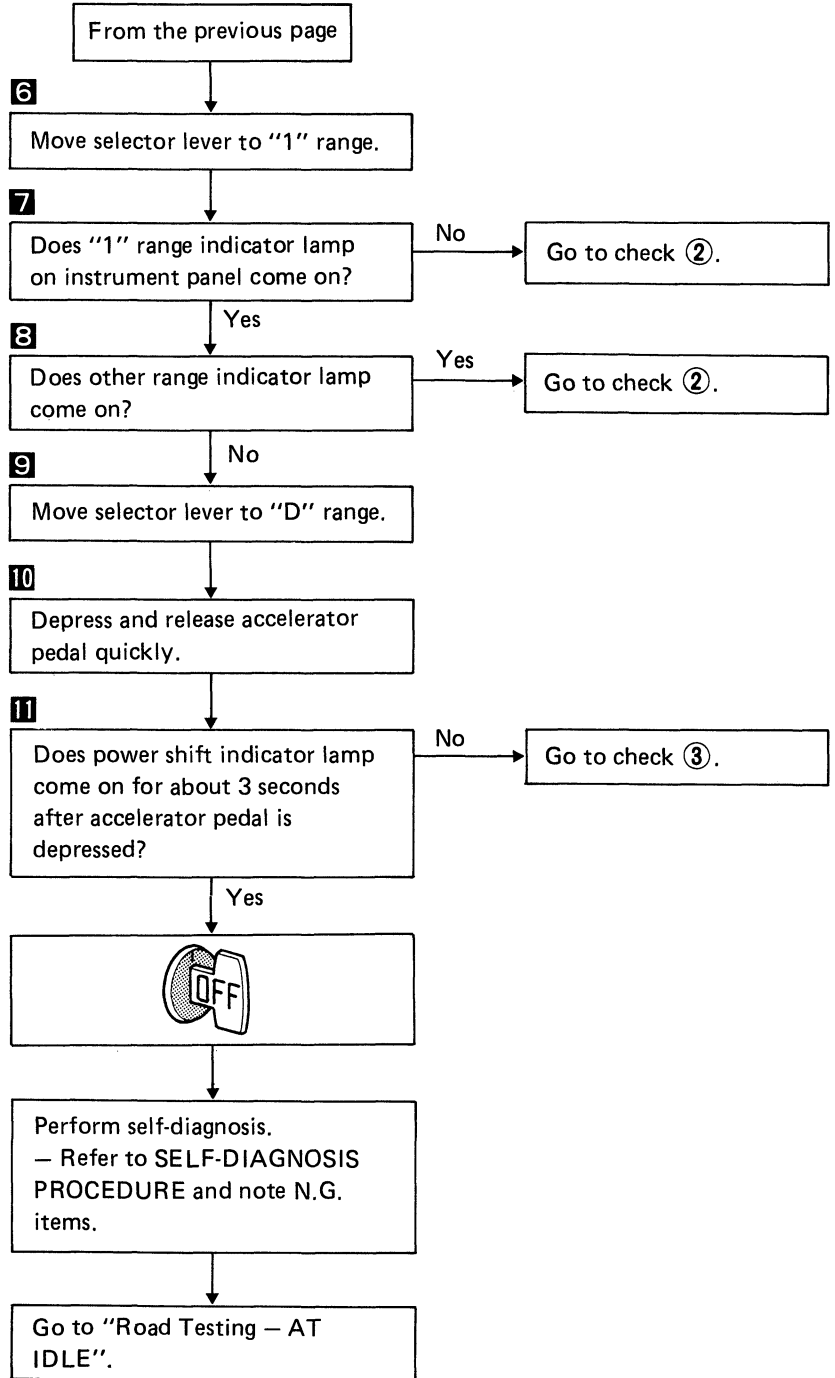
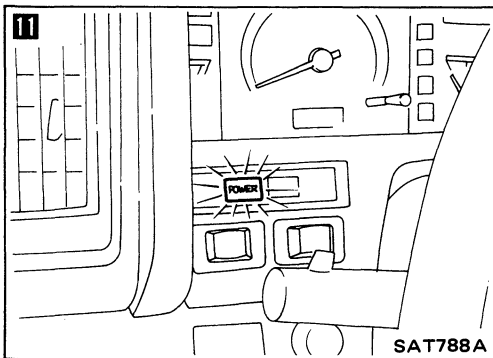
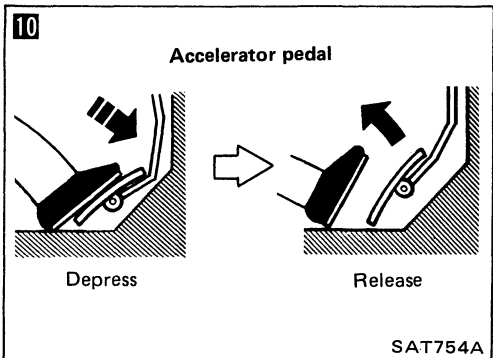
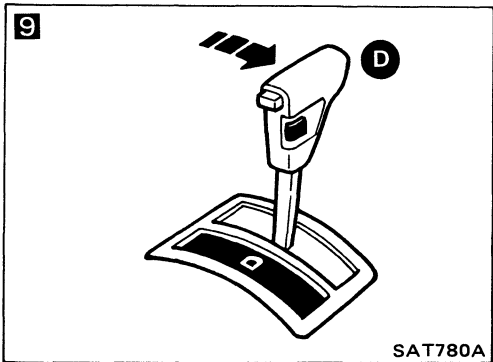
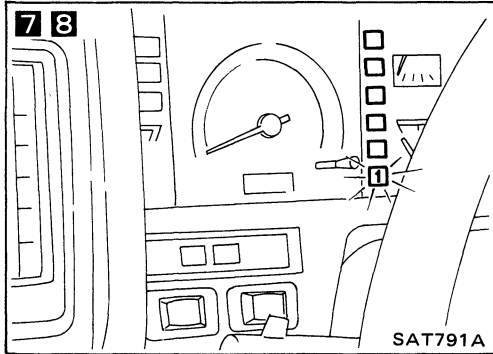
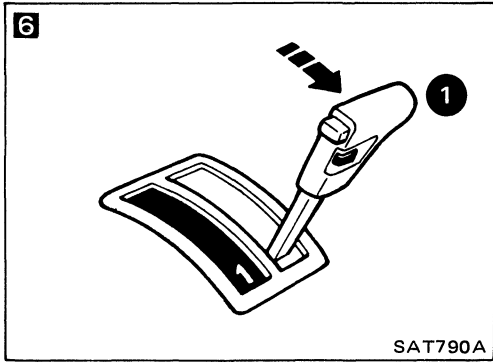

Road Testing (Cont'd)

2. CHECK AT IDLE

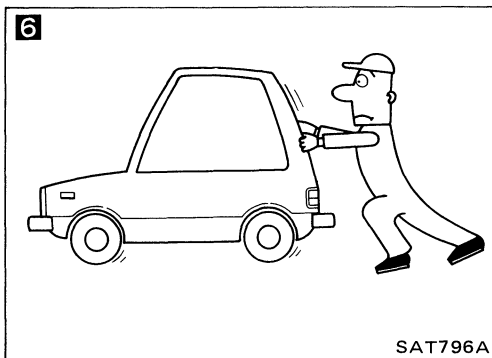
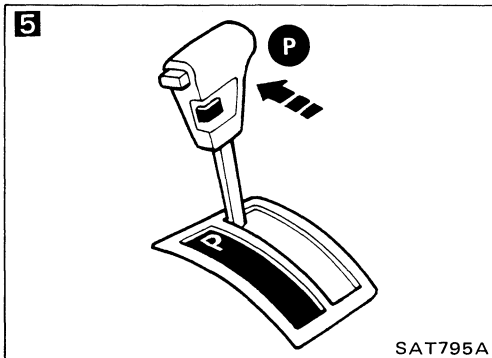
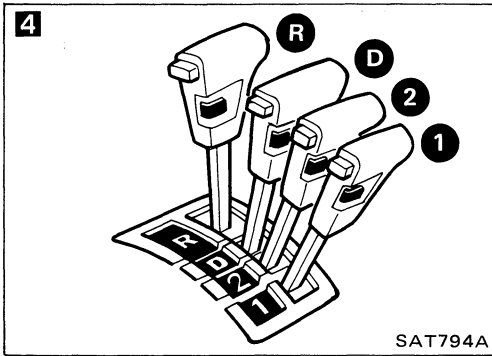
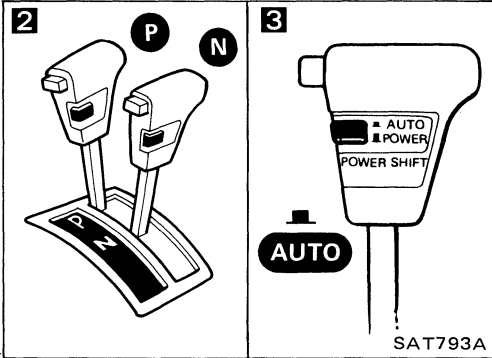
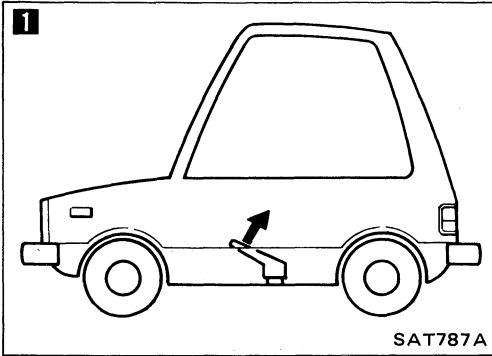

1
Park vehicle on flat surface.

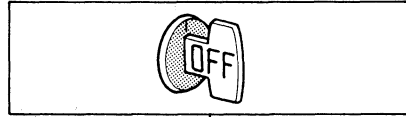

2
Move selector lever to "P" or "N" range.

3
Set power shift switch to "AUTO" position.

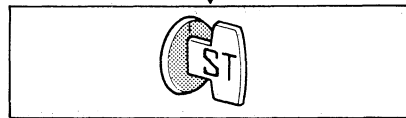

Is engine started? No → Go to check ④.
Yes



4
Move selector lever to "D", "1", "2" or "R" range.

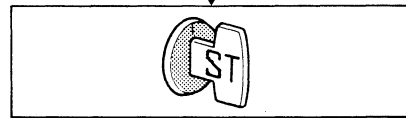

Is engine started? Yes → Go to check ④.
No



5
Move selector lever to "P" range.

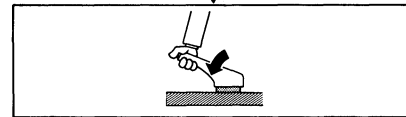

6
Push vehicle forward or backward.

Does vehicle move when it is pushed forward or backward? Yes → Go to check ⑤.
No

To the next page

Road Testing (Cont'd)

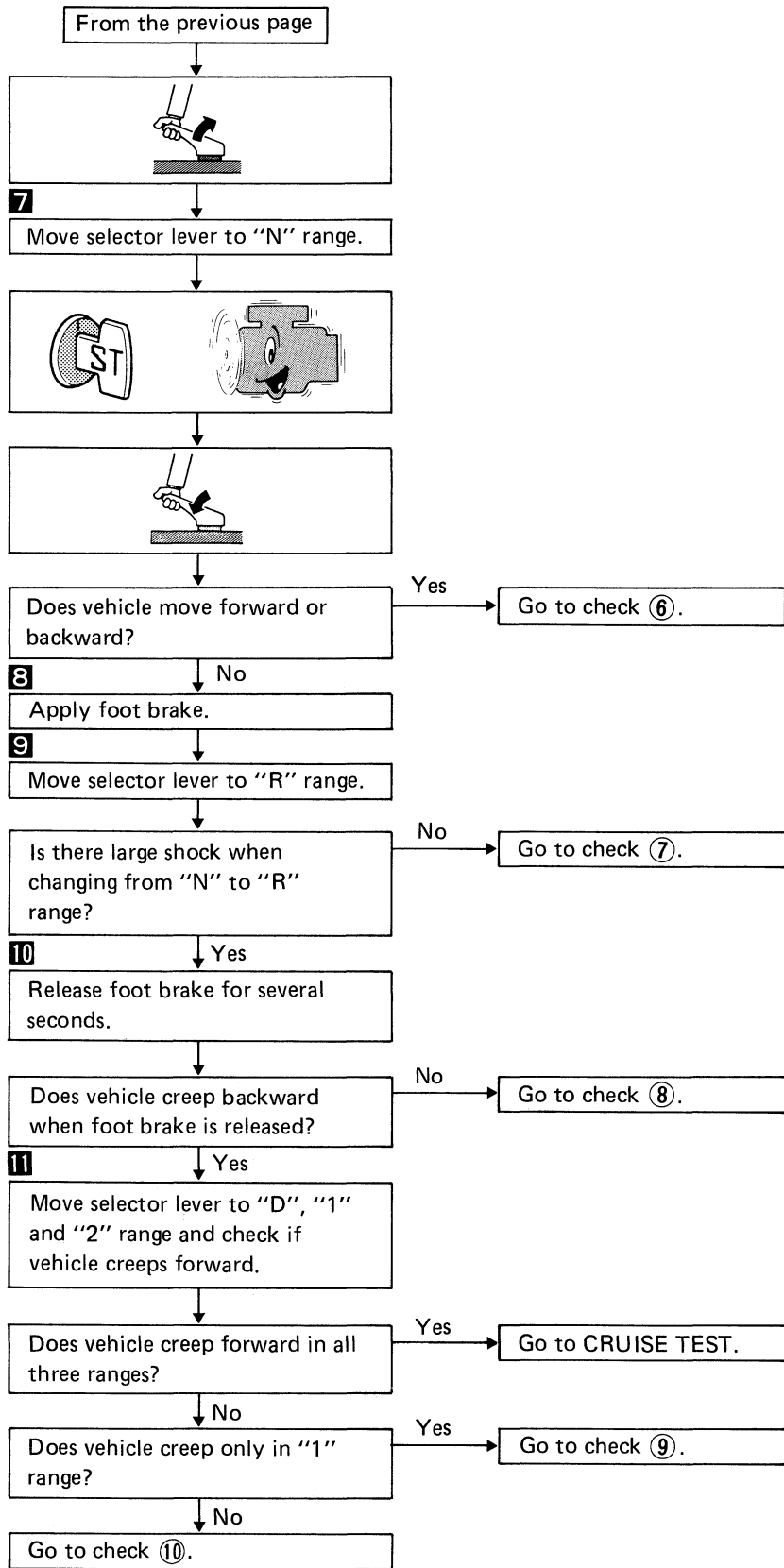
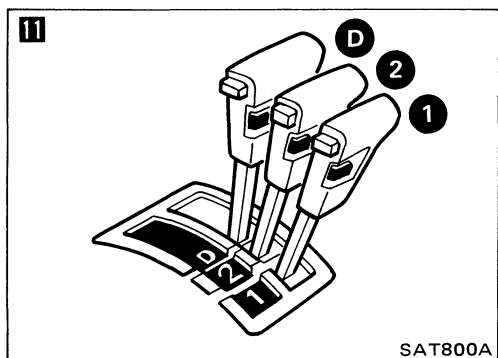
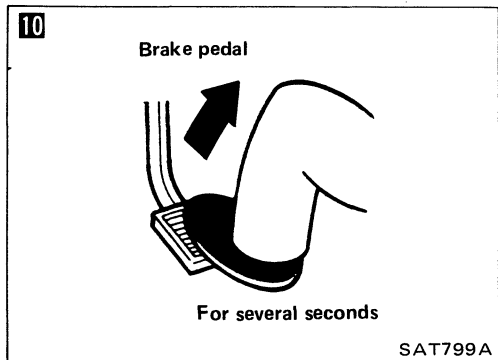
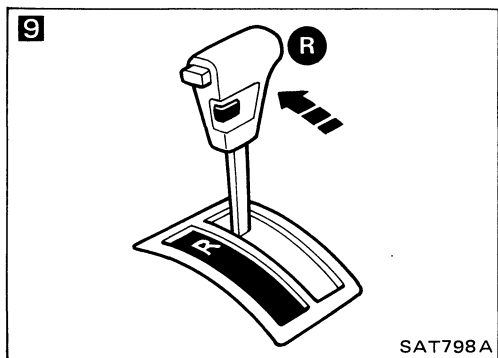
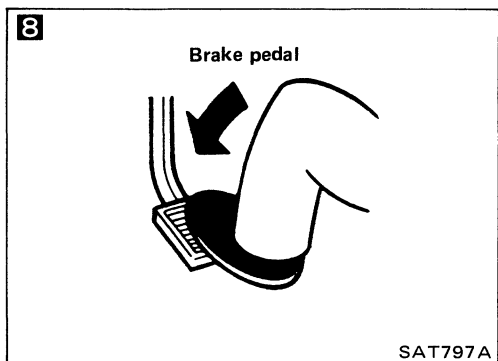
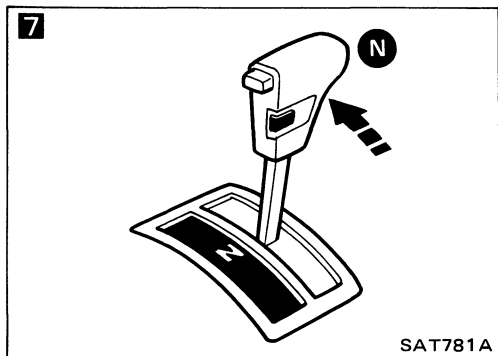

Road Testing (Cont'd)

3. CRUISE TEST

- Check all items listed in Parts 1 through 3.
- Throttle position can be controlled by voltage across terminals ⑪ and ⑮ of A/T control unit.

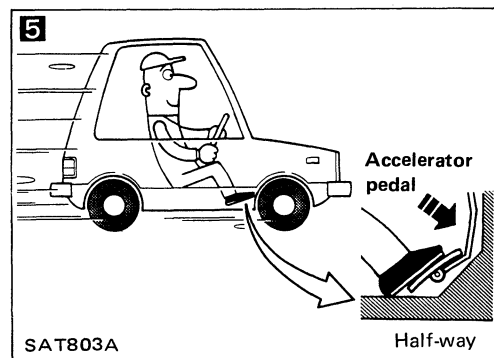
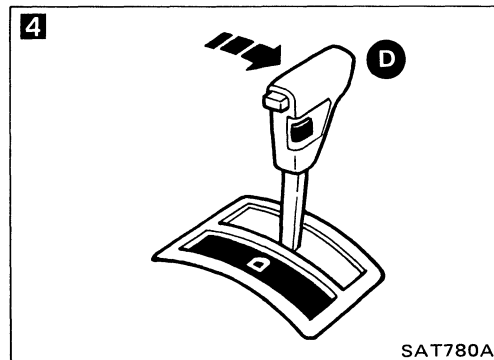
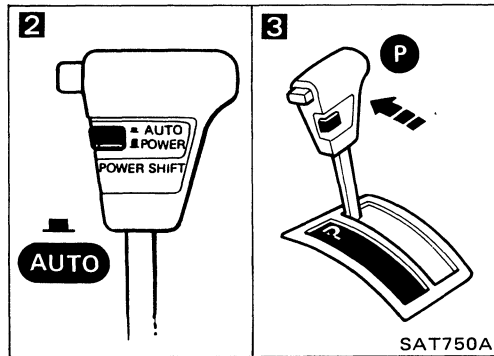
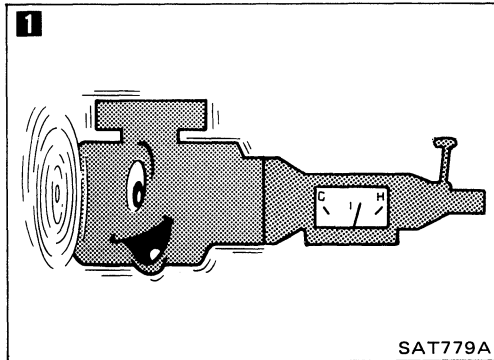
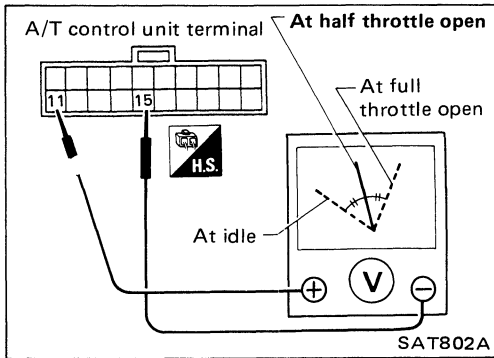

CRUISE TEST – Part 1

1

Warm up engine until engine oil and A.T.F. reach operating temperature after vehicle has been driven approx. 10 minutes.
A.T.F. operating temperature:
 50 - 80°C (122 - 176°F)

Park vehicle on flat surface.

2

Set power shift switch to "AUTO" position.

3

Move selector lever to "P" range.

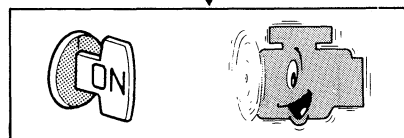

4

Move selector lever to "D" range.

5

Accelerate vehicle by constantly depressing accelerator pedal half-way.

Does vehicle start from D₁ ?

No → Go to check ⑪.

Yes → To the next page

Road Testing (Cont'd)

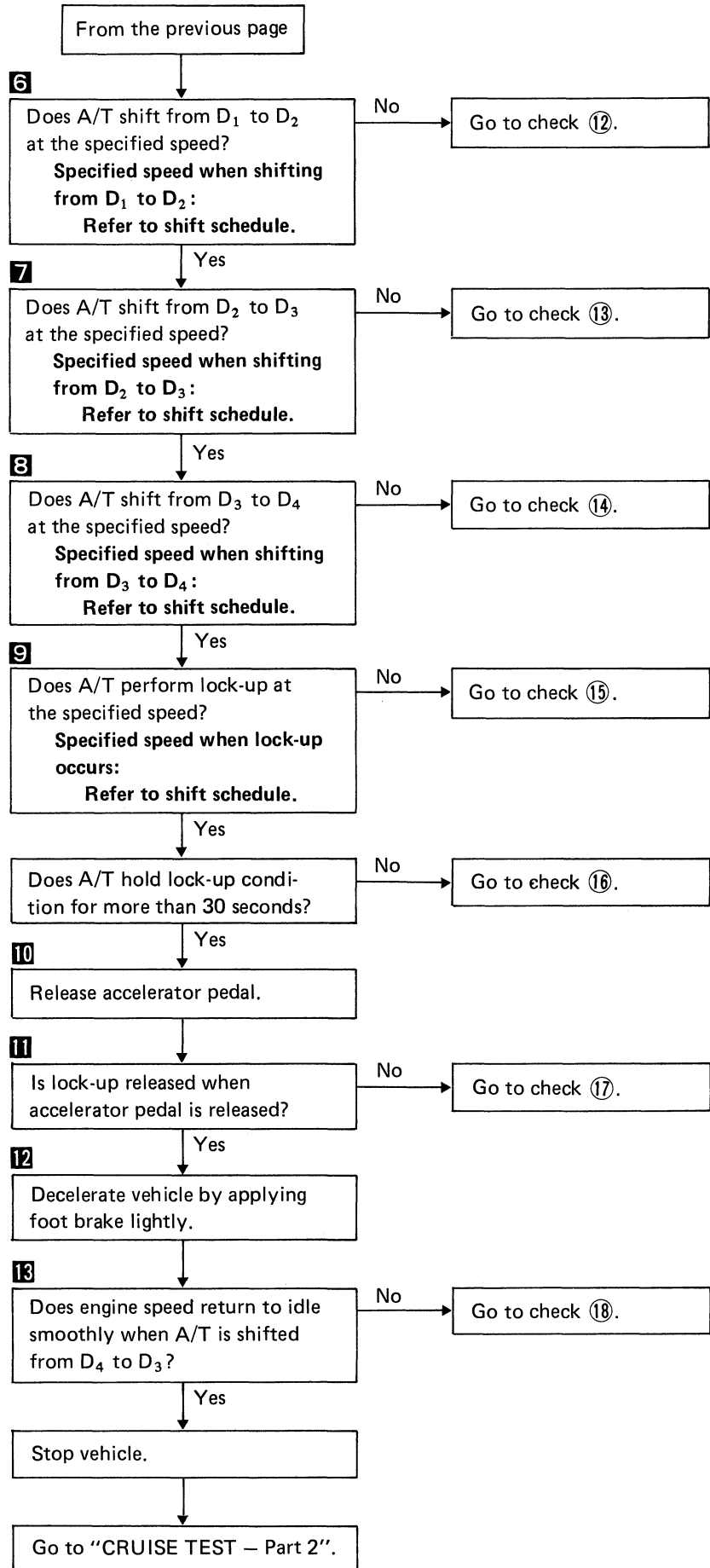
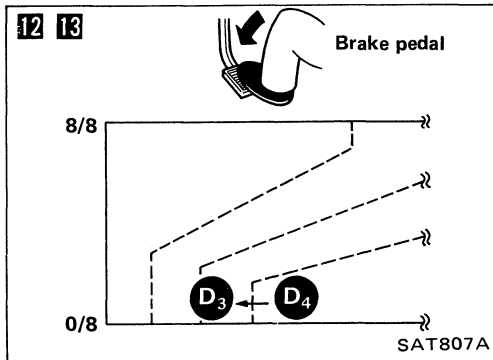
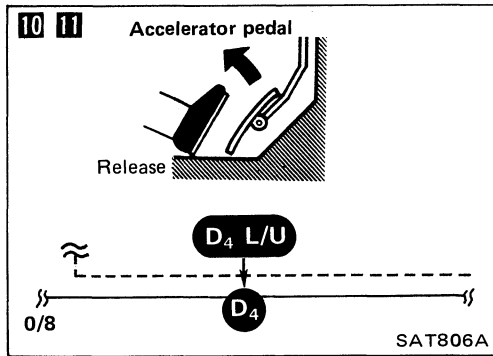
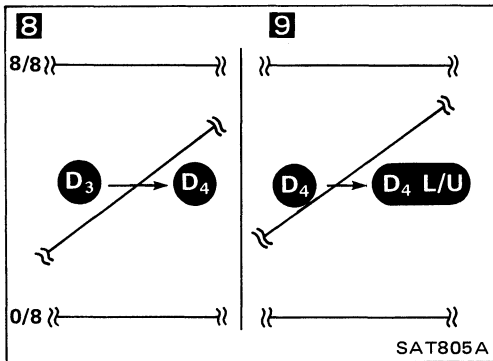
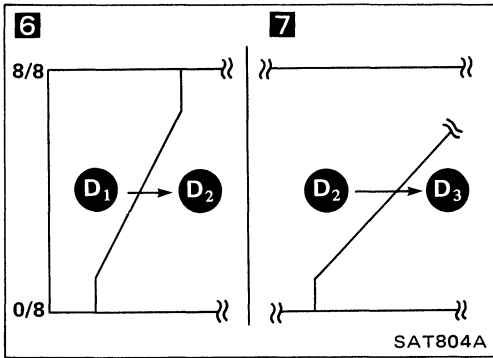

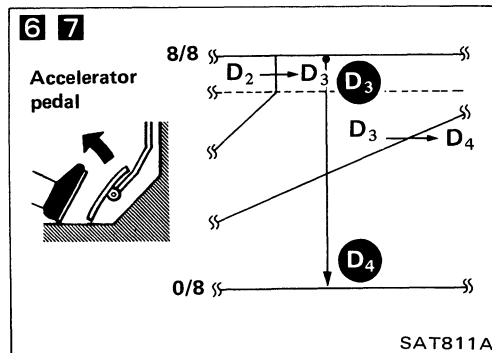
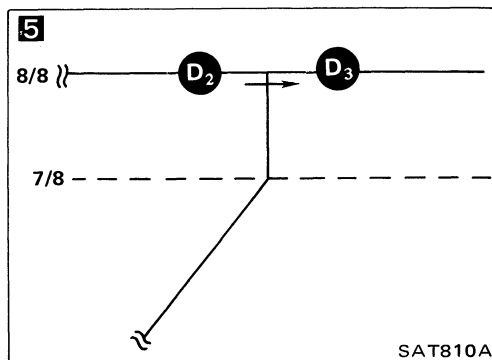
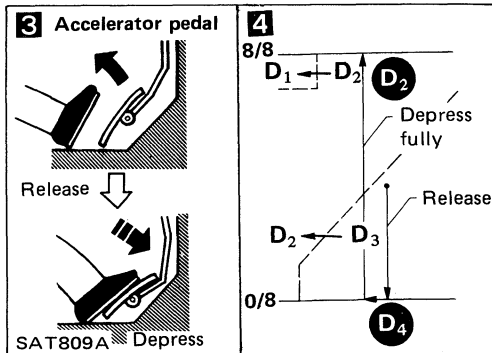
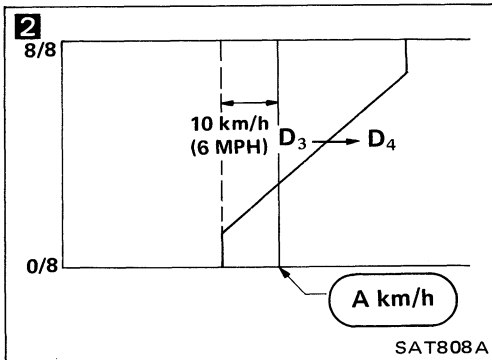
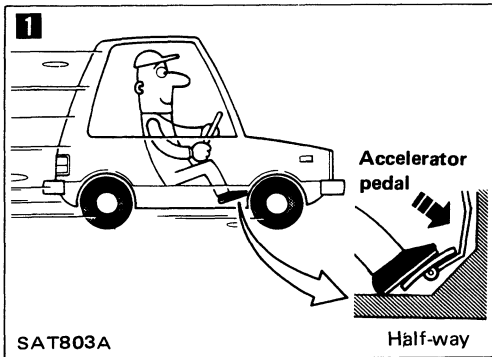

Road Testing (Cont'd)
CRUISE TEST – Part 2

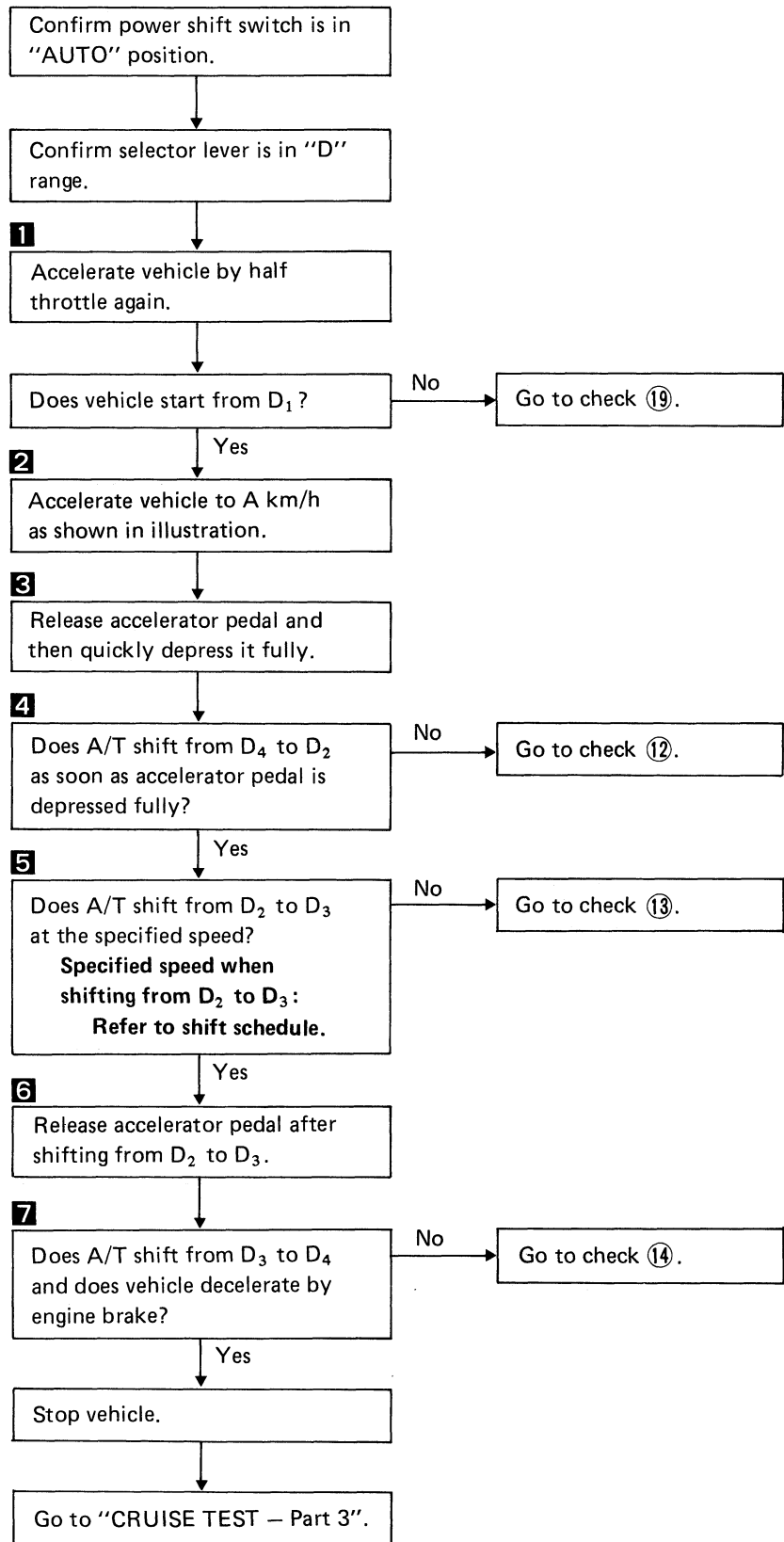

Road Testing (Cont'd)

CRUISE TEST – Part 3

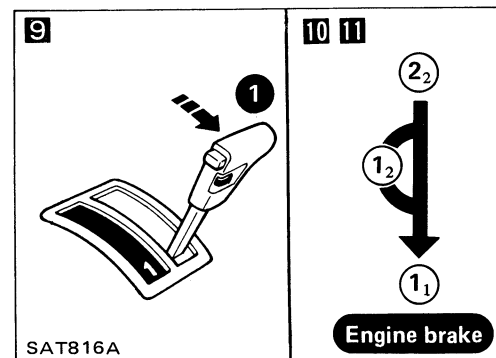
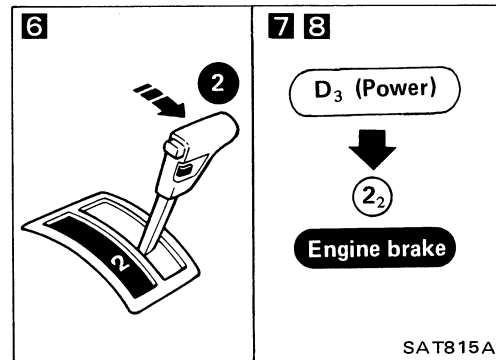
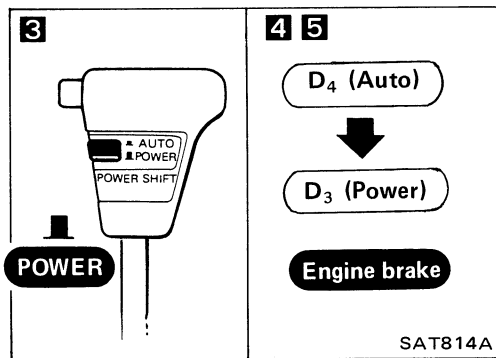
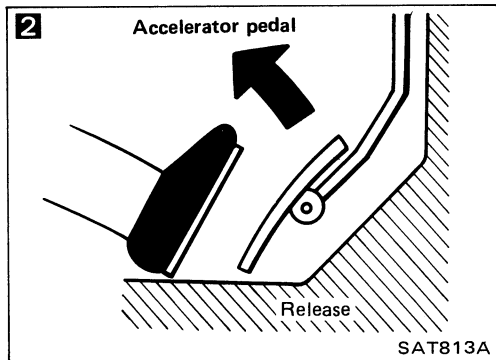
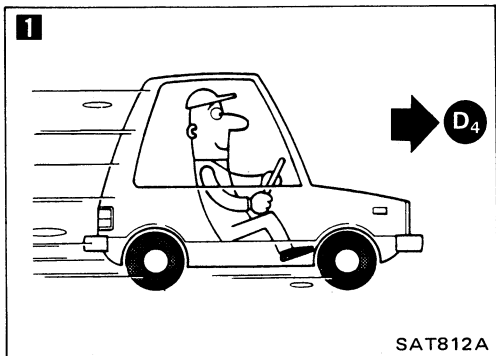

Confirm power shift switch is in "AUTO" position.

Confirm selector lever is in "D" range.

1 Accelerate vehicle using half-throttle to D₄.

2 Release accelerator pedal.

3 Set power shift switch to "POWER" position while driving in D₄ range.

4 Does A/T shift from D₄ to D₃? No → Go to check 20.

5 Does vehicle decelerate by engine brake? No → Go to check 18.

6 Move selector lever from "D" to "2" range while driving in D₃.

7 Does A/T shift from D₃ to 2₂? No → Go to check 21.

8 Does vehicle decelerate by engine brake? No → Go to check 18.

9 Move selector lever from "2" to "1" range while driving in 2₂.

10 Does A/T shift from 2₂ to 1₁ range? No → Go to check 22.

11 Does vehicle decelerate by engine brake? No → Go to check 23.

Stop vehicle.

Perform self-diagnosis. — Refer to SELF-DIAGNOSIS PROCEDURE.

Road Testing (Cont'd)

VEHICLE SPEED WHEN SHIFTING GEARS

Model	Throttle position	Shift pattern	Vehicle speed km/h (MPH)						
			D ₁ → D ₂	D ₂ → D ₃	D ₃ → D ₄	D ₄ → D ₃	D ₃ → D ₂	D ₂ → D ₁	1 ₂ → 1 ₁
VG30i 4WD	Full throttle	Standard	50 - 54 (31 - 34)	93 - 101 (58 - 63)	150 - 160 (93 - 99)	145 - 155 (90 - 96)	86 - 94 (53 - 58)	38 - 42 (24 - 26)	38 - 42 (24 - 26)
		Power	50 - 54 (31 - 34)	93 - 101 (58 - 63)	150 - 160 (93 - 99)	145 - 155 (90 - 96)	86 - 94 (53 - 58)	38 - 42 (24 - 26)	38 - 42 (24 - 26)
	Half throttle	Standard	31 - 35 (19 - 22)	60 - 66 (37 - 41)	99 - 107 (62 - 66)	63 - 71 (39 - 44)	29 - 35 (18 - 22)	10 - 14 (6 - 9)	38 - 42 (24 - 26)
		Power	42 - 46 (26 - 29)	84 - 90 (52 - 56)	119 - 127 (74 - 79)	104 - 112 (65 - 70)	55 - 61 (34 - 38)	10 - 14 (6 - 9)	38 - 42 (24 - 26)

VEHICLE SPEED WHEN PERFORMING AND RELEASING LOCK-UP

Model	Throttle position	Shift pattern	D ₄	
			Vehicle speed km/h (MPH)	
			Lock-up "ON"	Lock-up "OFF"
VG30i 4WD	Full throttle	Standard	150 - 160 (93 - 99)	145 - 155 (90 - 96)
		Power	150 - 160 (93 - 99)	145 - 155 (90 - 96)
	Half throttle	Standard	101 - 109 (63 - 68)	71 - 79 (44 - 49)
		Power	119 - 127 (74 - 79)	104 - 112 (65 - 70)

Road Testing (Cont'd)

SHIFT SCHEDULE — Standard Pattern

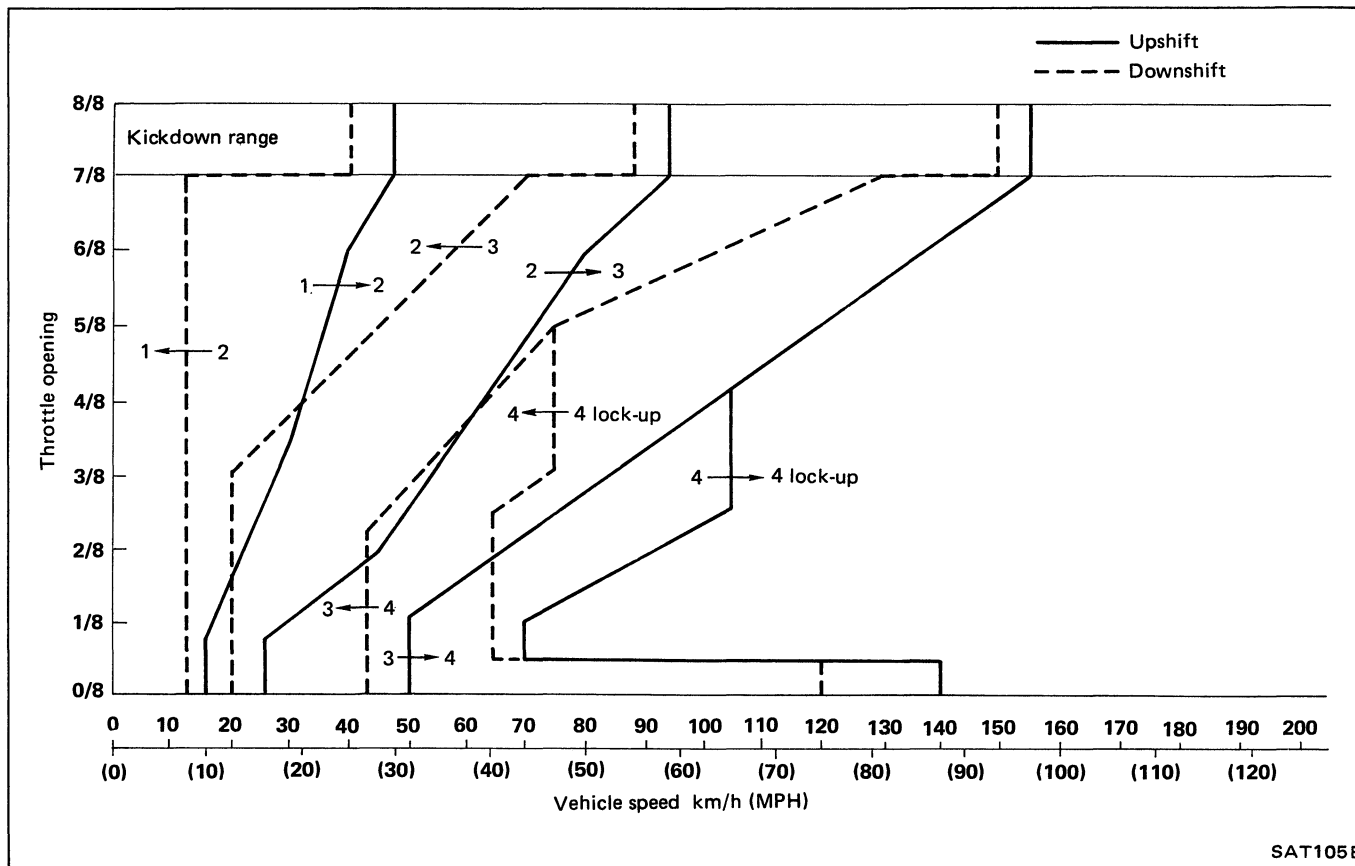

SAT105B

SHIFT SCHEDULE — Power Pattern

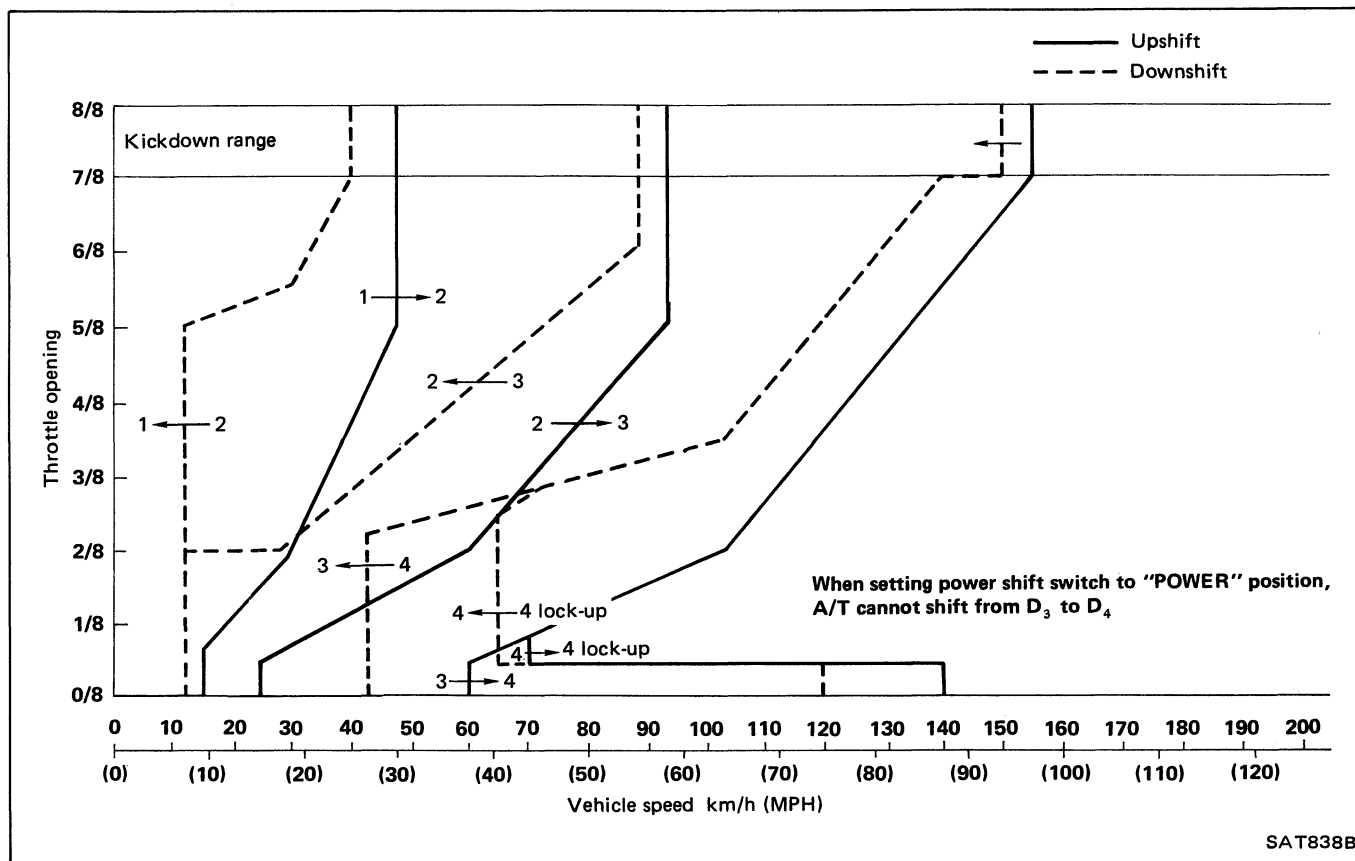

SAT838B

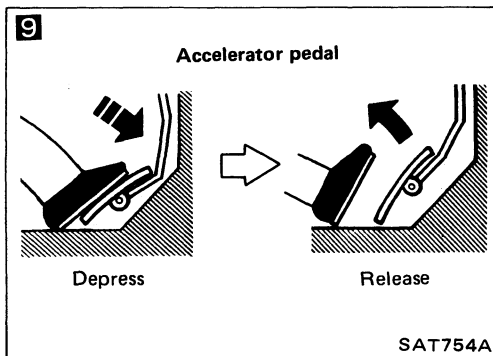
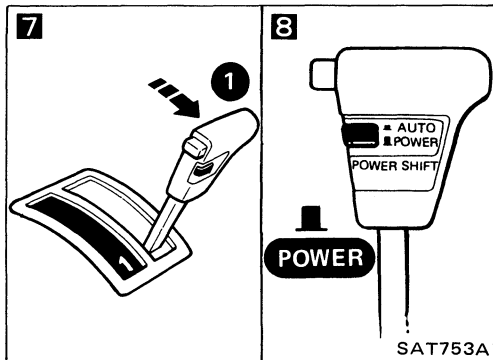
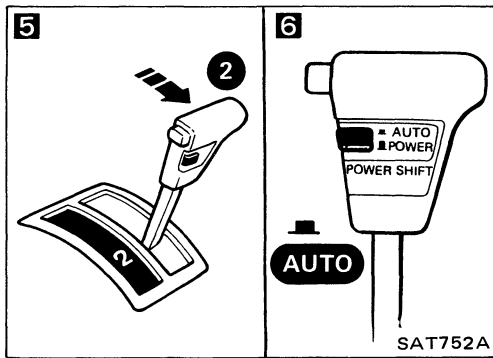
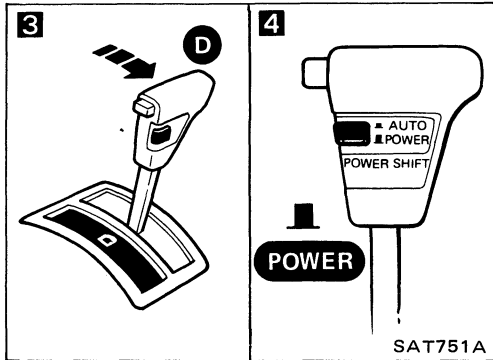
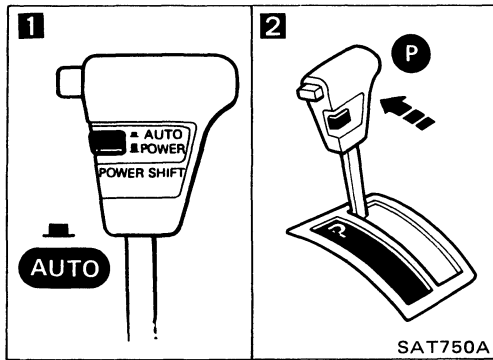

Trouble-shooting — Self-diagnosis
SELF-DIAGNOSIS PROCEDURE

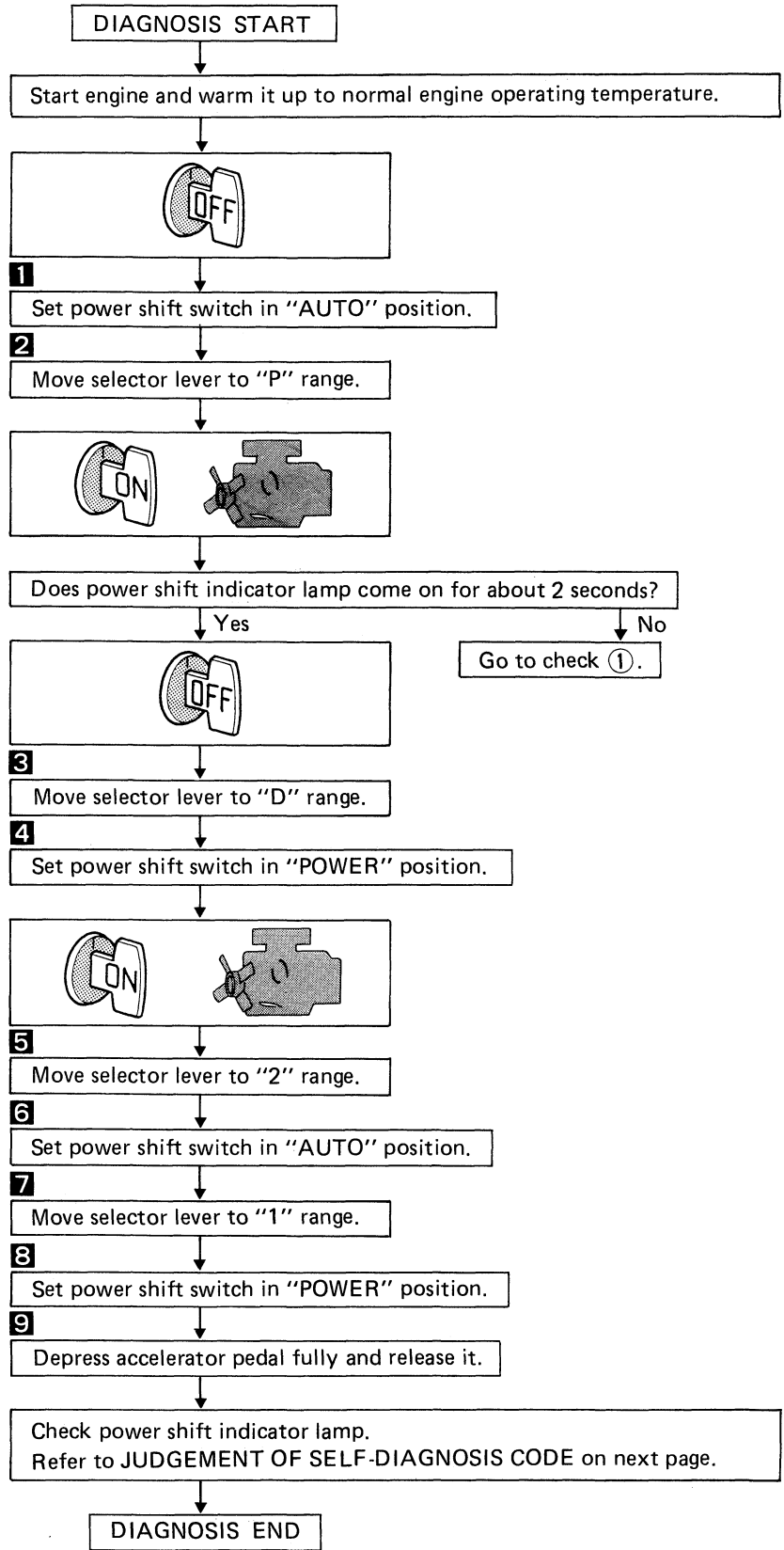

Trouble-shooting — Self-diagnosis (Cont'd)

JUDGEMENT OF SELF-DIAGNOSIS CODE

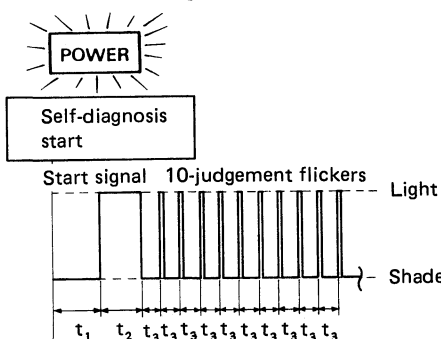
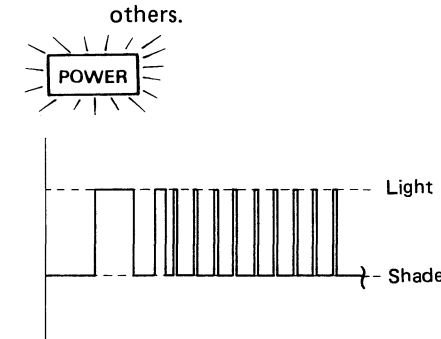
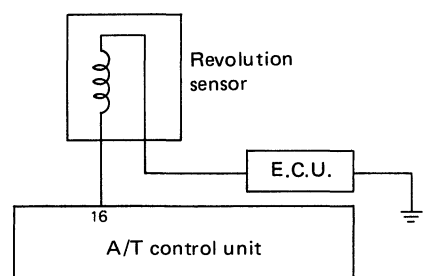
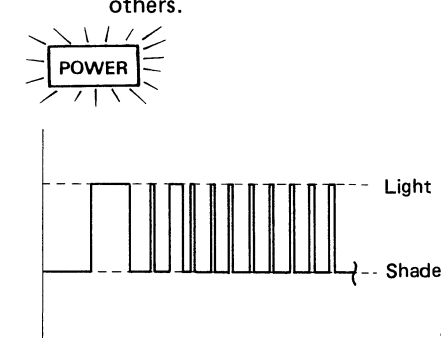
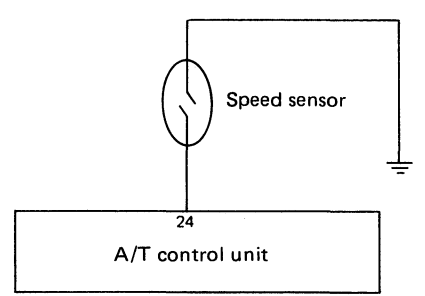
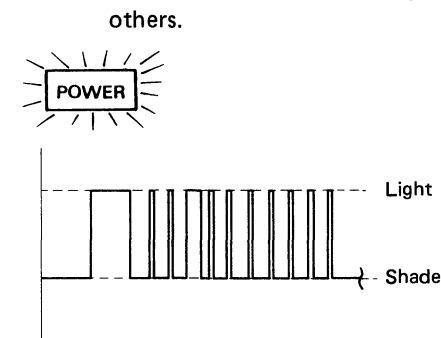
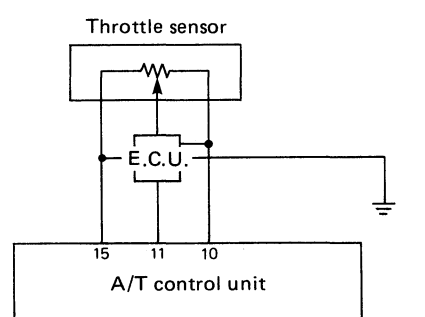
Power shift indicator lamp:	Damaged circuit
<p>All judgement flickers are same.</p>  <p>SAT755A</p>	<p>All circuits that can be confirmed by self-diagnosis are O.K.</p>
<p>1st judgement flicker is longer than others.</p>  <p>SAT756A</p>	<p>Revolution sensor circuit is short-circuited or disconnected.</p>  <p>➡ Go to revolution sensor circuit check. SAT759A</p>
<p>2nd judgement flicker is longer than others.</p>  <p>SAT757A</p>	<p>Speed sensor circuit is short-circuited or disconnected.</p>  <p>➡ Go to speed sensor circuit check. SAT760A</p>
<p>3rd judgement flicker is longer than others.</p>  <p>SAT758A</p>	<p>Throttle sensor circuit is short-circuited or disconnected.</p>  <p>➡ Go to throttle sensor circuit check. SAT761A</p>

t₁ = 2.5 seconds t₂ = 2.0 seconds t₃ = 1.0 second

Trouble-shooting — Self-diagnosis (Cont'd)

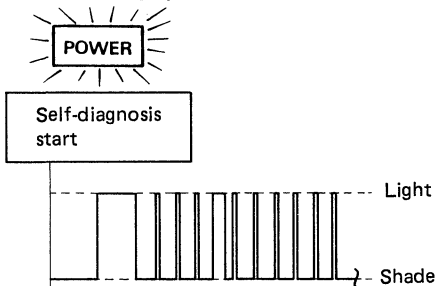
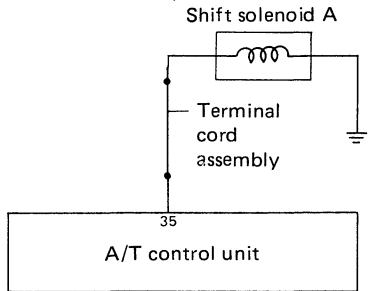
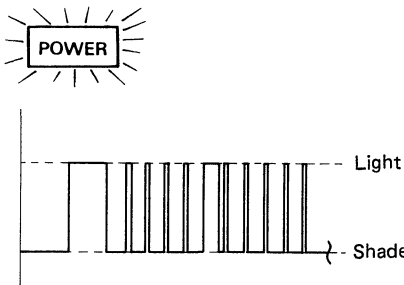
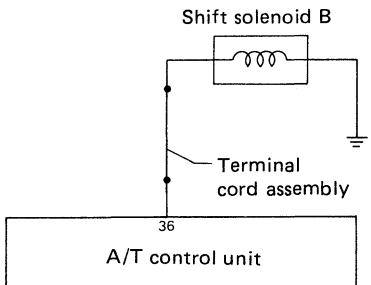
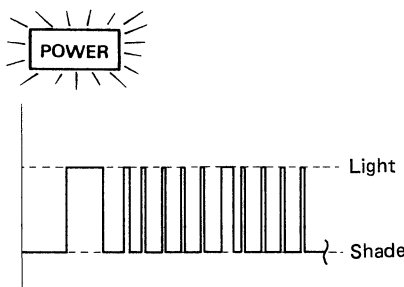
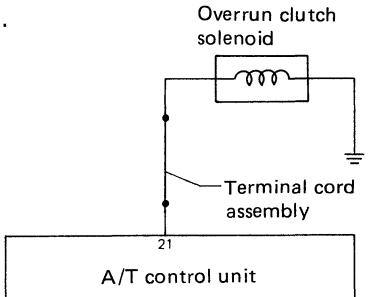
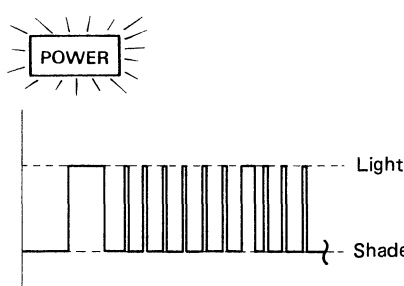
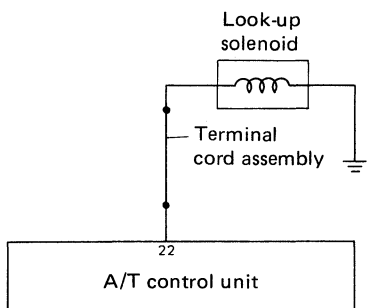
Power shift indicator lamp:	Damaged circuit
<p>4th judgement flicker is longer than others.</p>  <p>SAT762A</p>	<p>Shift solenoid A circuit is short-circuited or disconnected.</p>  <p>➡ Go to shift solenoid A circuit check.</p> <p>SAT766A</p>
<p>5th judgement flicker is longer than others.</p>  <p>SAT763A</p>	<p>Shift solenoid B circuit is short-circuited or disconnected.</p>  <p>➡ Go to shift solenoid B circuit check.</p> <p>SAT767A</p>
<p>6th judgement flicker is longer than others.</p>  <p>SAT764A</p>	<p>Overrun clutch solenoid circuit is short-circuited or disconnected.</p>  <p>➡ Go to overrun clutch solenoid circuit check.</p> <p>SAT768A</p>
<p>7th judgement flicker is longer than others.</p>  <p>SAT765A</p>	<p>Lock-up solenoid circuit is short-circuited or disconnected.</p>  <p>➡ Go to lock-up solenoid circuit check.</p> <p>SAT769A</p>

Trouble-shooting — Self-diagnosis (Cont'd)

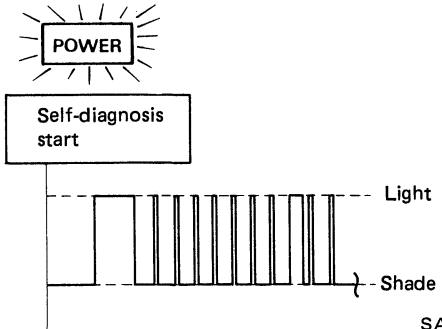
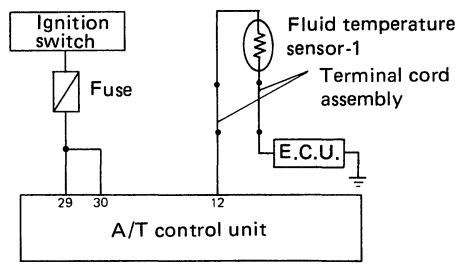
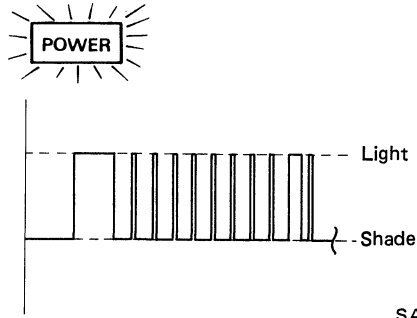
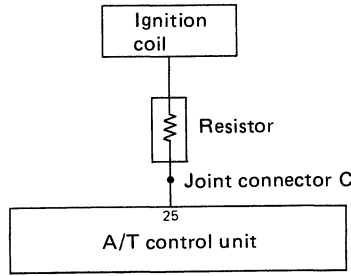
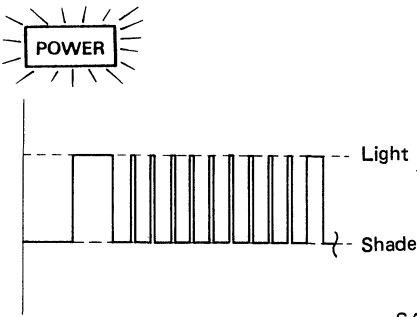
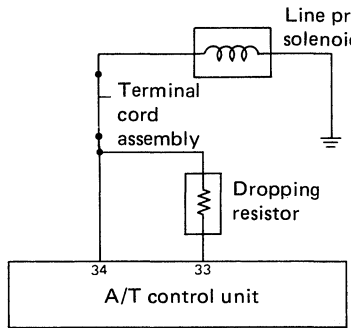
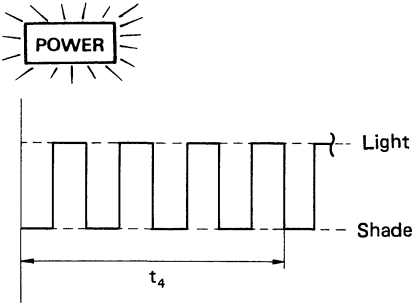
Power shift indicator lamp:	Damaged circuit
<p>8th judgement flicker is longer than others.</p>  <p>SAT770A</p>	<p>Fluid temperature sensor-1 is disconnected or A/T control unit power source circuit is damaged.</p>  <p>➡ Go to fluid temperature sensor-1 and A/T control unit power source circuit check.</p> <p>SAT774A</p>
<p>9th judgement flicker is longer than others.</p>  <p>SAT771A</p>	<p>Engine revolution signal circuit is short-circuited or disconnected.</p>  <p>➡ Go to engine revolution signal circuit check.</p> <p>SAT775A</p>
<p>10th judgement flicker is longer than others.</p>  <p>SAT772A</p>	<p>Line pressure solenoid circuit is short-circuited or disconnected.</p>  <p>➡ Go to line pressure solenoid circuit check.</p> <p>SAT776A</p>
<p>Flickers as shown below.</p>  <p>SAT773A</p>	<p>Battery power is low. Battery has been disconnected for a long time. Battery is connected conversely. (When reconnecting A/T control unit connectors. — This is not a problem.)</p>

t₄ = 1.0 second

Trouble-shooting — Self-diagnosis (Cont'd)

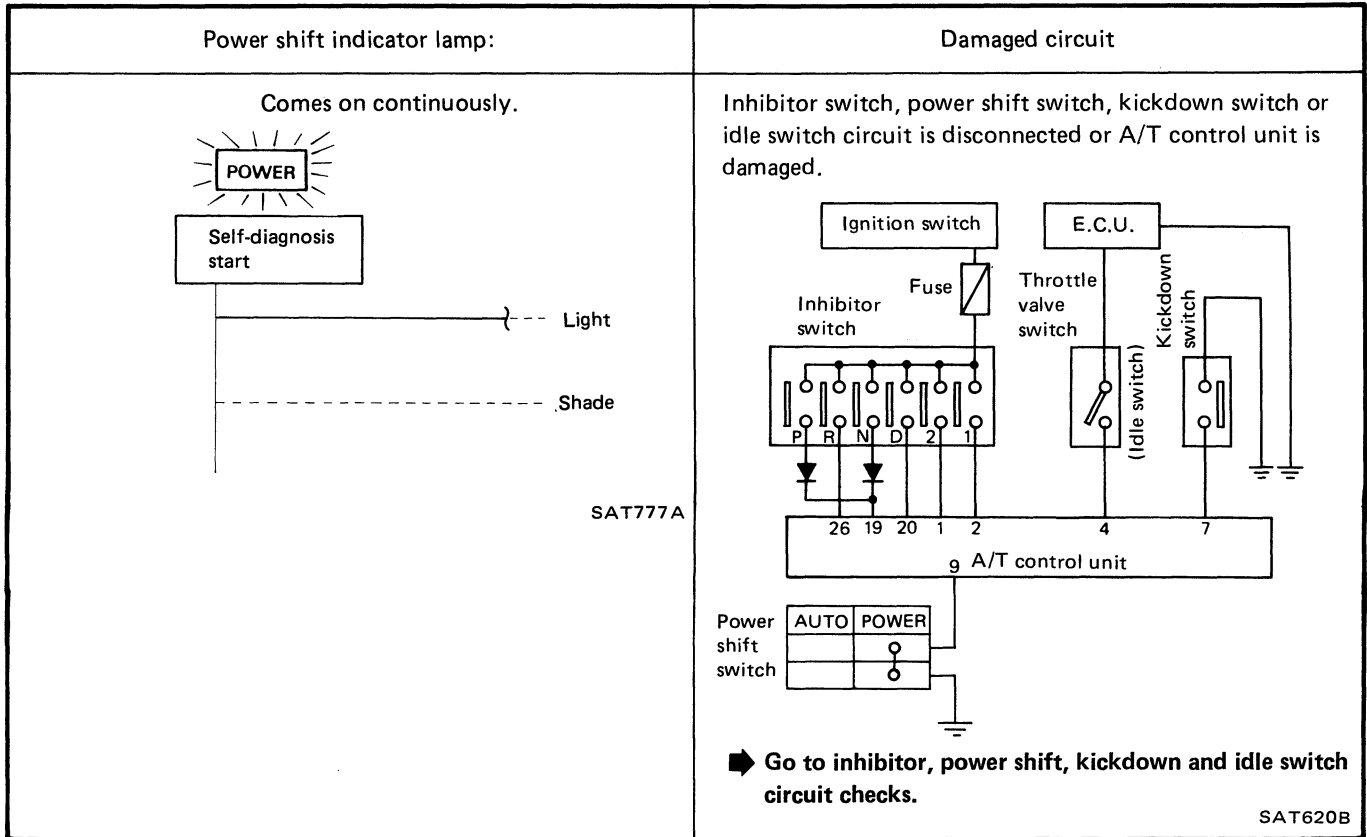

Trouble-shooting — Self-diagnosis (Cont'd)
REVOLUTION SENSOR CIRCUIT CHECK

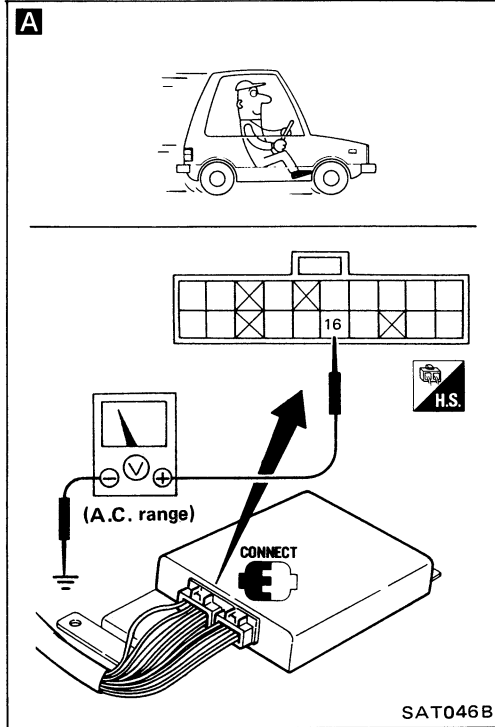
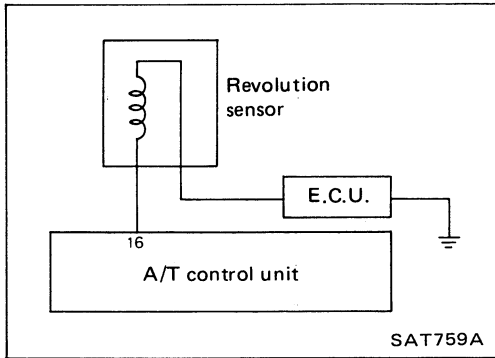

CHECK REVOLUTION SENSOR — Refer to "Electrical System".

N.G. → Repair or replace revolution sensor.

A

CHECK INPUT SIGNAL

1. 16

2. Check voltage between A/T control unit terminal ①⑥ and ground while driving. (Measure with A.C. range.)

Voltage:
 at 0 km/h (0 MPH): 0V
 at 30 km/h (19 MPH): 1V or more
 (Voltage rises gradually in response to vehicle speed)

N.G. → Check the following items.

- Harness continuity between A/T control unit and revolution sensor (Main harness)
- Harness continuity between revolution sensor and E.C.U. (Main harness)
- Ground circuit for E.C.U. — Refer to section EF & EC.

O.K. → Perform self-diagnosis again after driving for a while.

N.G. → 1. Perform A/T control unit input/output signal inspection.
 2. If N.G., recheck A/T control unit pin terminals for damage or connection of A/T control unit harness connector.

O.K. → **INSPECTION END**

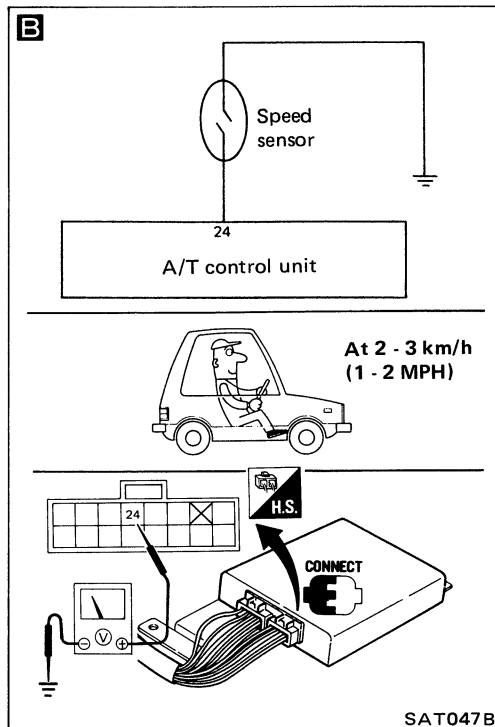

SPEED SENSOR CIRCUIT CHECK

B

CHECK INPUT SIGNAL

1. 24

2. Check voltage between A/T control unit terminal ②④ and ground while driving at 2 to 3 km/h (1 to 2 MPH) for 1 m (3 ft) or more.

Voltage: Varies from 0V to 5V

N.G. → Check the following items.

- Speed sensor and ground circuit for speed sensor — Refer to section EL.
- Harness continuity between A/T control unit and speed sensor (Main harness)

O.K. → Perform self-diagnosis again after driving for a while.

N.G. → 1. Perform A/T control unit input/output signal inspection.
 2. If N.G., recheck A/T control unit pin terminals for damage or connection of A/T control unit harness connector.

O.K. → **INSPECTION END**

Trouble-shooting — Self-diagnosis (Cont'd)

THROTTLE SENSOR CIRCUIT CHECK

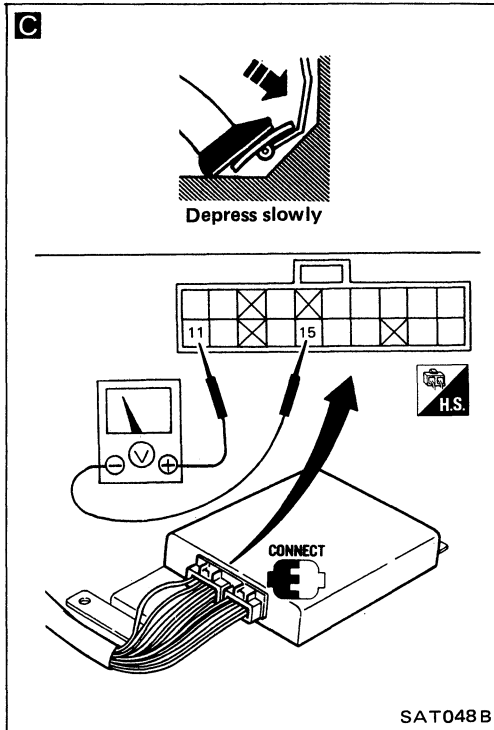
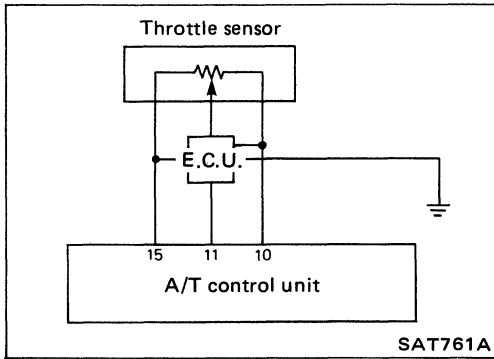

```

    graph TD
      A[Perform self-diagnosis (Mode III) for engine control.] -- N.G. --> B[Check throttle sensor circuit for engine control. — Refer to section EF & EC.]
      A -- O.K. --> C[CHECK INPUT SIGNAL]
      C -- N.G. --> D[Check harness continuity between E.C.U. and A/T control unit regarding throttle sensor circuit. (Main harness)]
      C -- O.K. --> E[Perform self-diagnosis again after driving for a while.]
      E -- N.G. --> F[1. Perform A/T control unit input/output signal inspection.  
2. If N.G., recheck A/T control unit pin terminals for damage or connection of A/T control unit harness connector.]
      E -- O.K. --> G[INSPECTION END]
  
```

C

CHECK INPUT SIGNAL

-
- Check voltage between A/T control unit terminals ⑪ and ⑮ while accelerator pedal is depressed slowly.
Voltage:
 Fully-closed throttle: 0.2 - 0.6V
 Fully-open throttle: 2.9 - 3.9V
 (Voltage rises gradually in response to throttle valve opening.)

Trouble-shooting — Self-diagnosis (Cont'd)

SHIFT SOLENOID A CIRCUIT CHECK

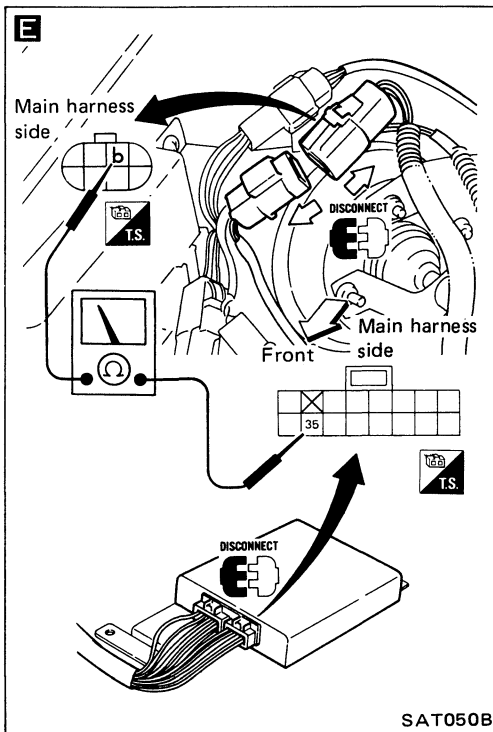
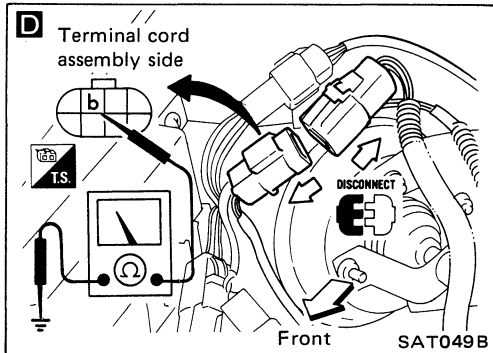
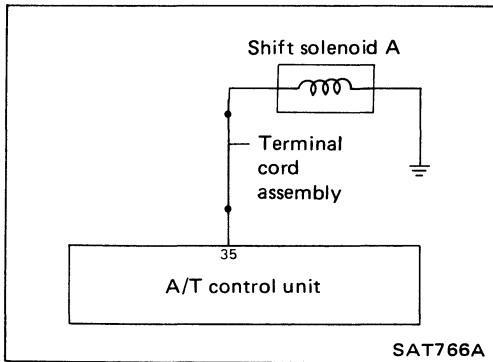

D

CHECK GROUND CIRCUIT

1.

2. Disconnect terminal cord assembly connector in engine compartment.

3. Check resistance between terminal **b** and ground.
Resistance: 20 - 30Ω

N.G.

1. Remove control valve assembly. — Refer to "ON-VEHICLE SERVICE".
2. Check the following items.
 - Shift solenoid A — Refer to "Electrical System".
 - Harness continuity of terminal cord assembly

O.K.

E

CHECK POWER SOURCE CIRCUIT

1.

2. Disconnect A/T control unit 16-pin connector.

3. Check resistance between terminal **b** and A/T control unit terminal **35**.
Resistance:
Approximately 0Ω

4. Reinstall any part removed.

N.G.

Repair or replace harness between A/T control unit and terminal cord assembly. (Main harness)

O.K.

Perform self-diagnosis after driving for a while.

N.G.

1. Perform A/T control unit input/output signal inspection.
2. If N.G., recheck A/T control unit pin terminals for damage or connection of A/T control unit harness connector.

INSPECTION END

Trouble-shooting — Self-diagnosis (Cont'd)
SHIFT SOLENOID B CIRCUIT CHECK

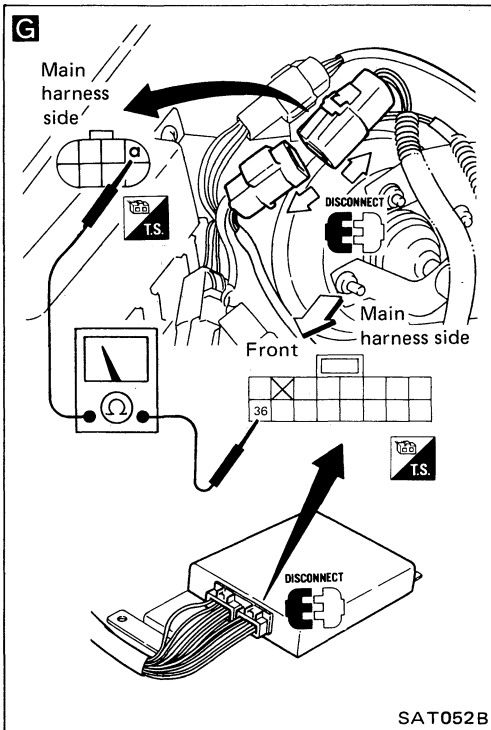
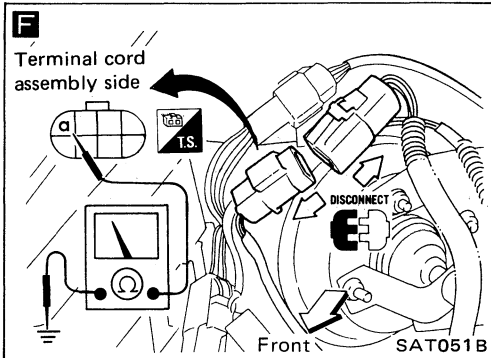
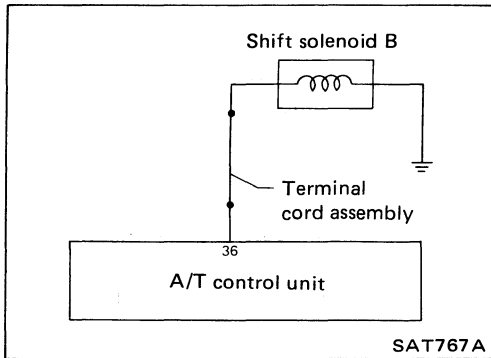

F

CHECK GROUND CIRCUIT

1. 
2. Disconnect terminal cord assembly connector in engine compartment.
3. Check resistance between terminal 36 and ground.
Resistance: 20 - 30Ω

- N.G.
1. Remove control valve assembly. — Refer to "ON-VEHICLE SERVICE".
 2. Check the following items.
 - Shift solenoid B — Refer to "Electrical System".
 - Harness continuity of terminal cord assembly

O.K.

G

CHECK POWER SOURCE CIRCUIT

1. 
2. Disconnect A/T control unit 16-pin connector.
3. Check resistance between terminal 36 and A/T control unit terminal 36.
Resistance: Approximately 0Ω
4. Reinstall any part removed.

- N.G.
- Repair or replace harness between A/T control unit and terminal cord assembly. (Main harness)

O.K.

Perform self-diagnosis after driving for a while.

O.K.

INSPECTION END

- N.G.
1. Perform A/T control unit input/output signal inspection.
 2. If N.G., recheck A/T control unit pin terminals for damage or connection of A/T control unit harness connector.

Trouble-shooting — Self-diagnosis (Cont'd)
OVERRUN CLUTCH SOLENOID CIRCUIT CHECK

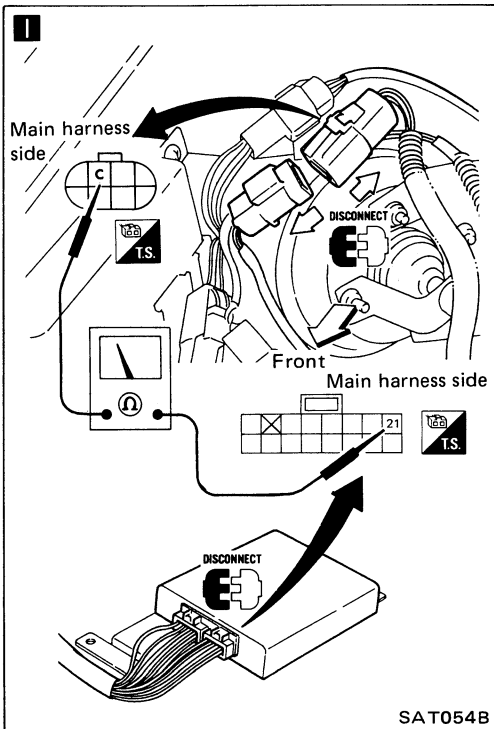
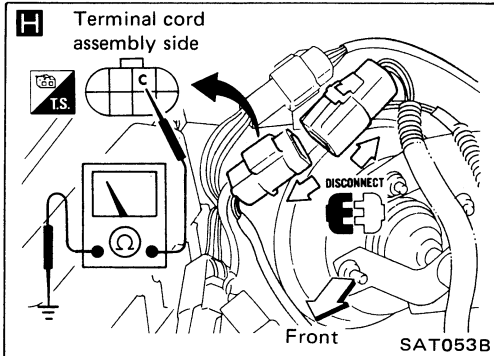
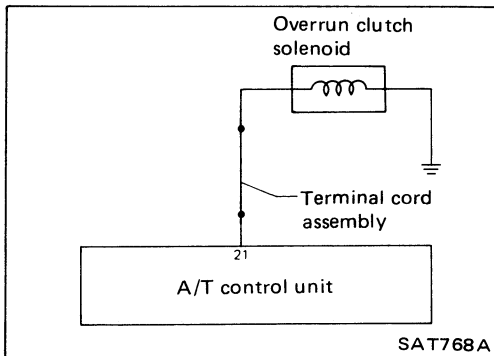

II

CHECK GROUND CIRCUIT

1.

2. Disconnect terminal cord assembly connector in engine compartment.

3. Check resistance between terminal C and ground.
Resistance: 20 - 30Ω

N.G.

1. Remove control valve assembly. — Refer to "ON-VEHICLE SERVICE".
2. Check the following items.
 - Overrun clutch solenoid. — Refer to "Electrical System".
 - Harness continuity of terminal cord assembly

O.K.

I

CHECK POWER SOURCE CIRCUIT

1.

2. Disconnect A/T control unit 16-pin connector.

3. Check resistance between terminal C and A/T control unit terminal 21.
Resistance: Approximately 0Ω

4. Reinstall any part removed.

N.G.

Repair or replace harness between A/T control unit and terminal cord assembly. (Main harness)

O.K.

Perform self-diagnosis after driving for a while.

O.K.

INSPECTION END

N.G.

1. Perform A/T control unit input/output signal inspection.
2. If N.G., recheck A/T control unit pin terminals for damage or connection of A/T control unit harness connector.

Trouble-shooting — Self-diagnosis (Cont'd)

LOCK-UP SOLENOID CIRCUIT CHECK

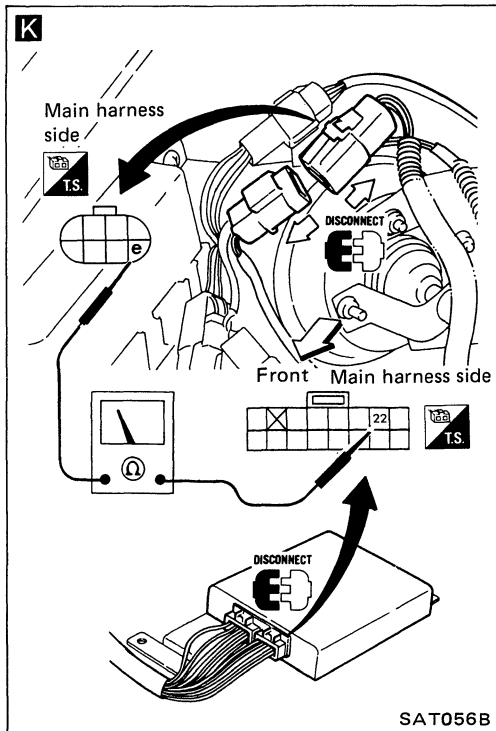
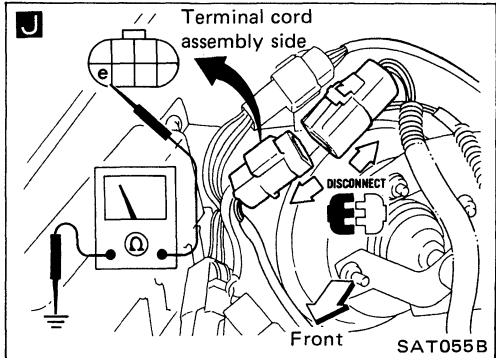
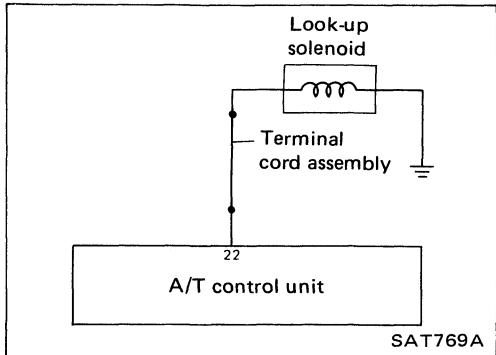

J

CHECK GROUND CIRCUIT

1. 

2. Disconnect terminal cord assembly connector in engine compartment.

3. Check resistance between terminal \ominus and ground.
Resistance: 2.5 - 5 Ω

N.G. →

1. Remove oil pan. — Refer to "ON-VEHICLE SERVICE".
2. Check the following items.
 - Lock-up solenoid — Refer to "Electrical System".
 - Harness continuity of terminal cord assembly

O.K. ↓

K

CHECK POWER SOURCE CIRCUIT

1. 

2. Disconnect A/T control unit 16-pin connector.

3. Check resistance between terminal \ominus and A/T control unit terminal 22.
Resistance: Approximately 0 Ω

4. Reinstall any part removed.

N.G. →

Repair or replace harness between A/T control unit and terminal cord assembly. (Main harness)

O.K. ↓

Perform self-diagnosis after driving for a while.

O.K. ↓

INSPECTION END

N.G. →

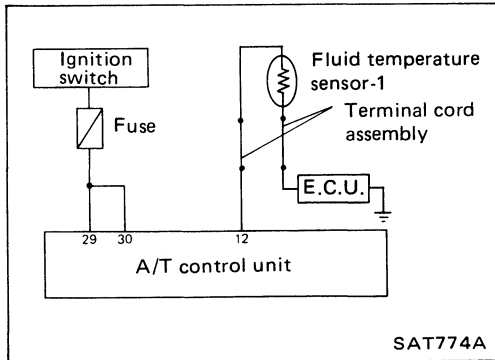

1. Perform A/T control unit input/output signal inspection.
2. If N.G., recheck A/T control unit pin terminals for damage or connection of A/T control unit harness connector.

Trouble-shooting — Self-diagnosis (Cont'd)
FLUID TEMPERATURE SENSOR-1 CIRCUIT AND A/T CONTROL UNIT POWER SOURCE CIRCUIT CHECK



L

CHECK A/T CONTROL UNIT POWER SOURCE

1.  
2. Check voltage between A/T control unit terminals ②⑨, ③⑩ and ground.
Battery voltage should exist.

N.G. → Check the following items.

- Harness continuity between ignition switch and A/T control unit (Main harness)
- Ignition switch and fuse — Refer to section EL.

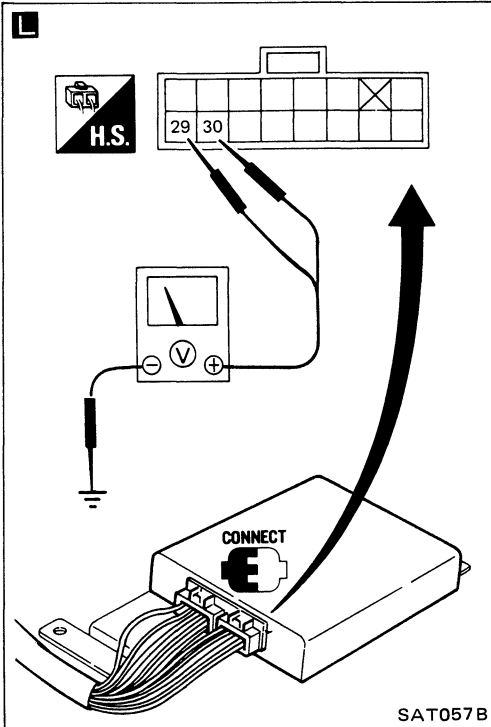

M

CHECK FLUID TEMPERATURE SENSOR-1 WITH TERMINAL CORD ASSEMBLY

1. 
2. Disconnect terminal cord assembly connector in engine compartment.
3. Check resistance between terminal ① and ② when A/T is cold.
Resistance:
Cold [20°C (68°F)]
Approximately 2.5 kΩ
4. Reinstall any part removed.

N.G. →

1. Remove oil pan.
2. Check the following items.
 - Fluid temperature sensor — Refer to "Electrical System".
 - Harness continuity of terminal cord assembly

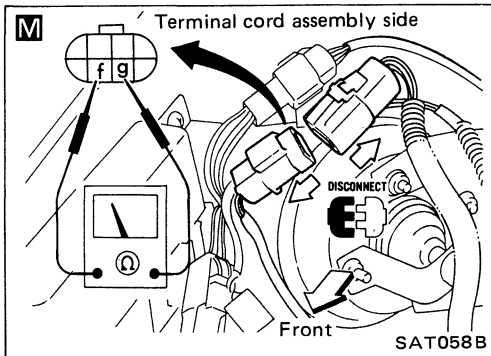

O.K. →

To the next page

Trouble-shooting — Self-diagnosis (Cont'd)

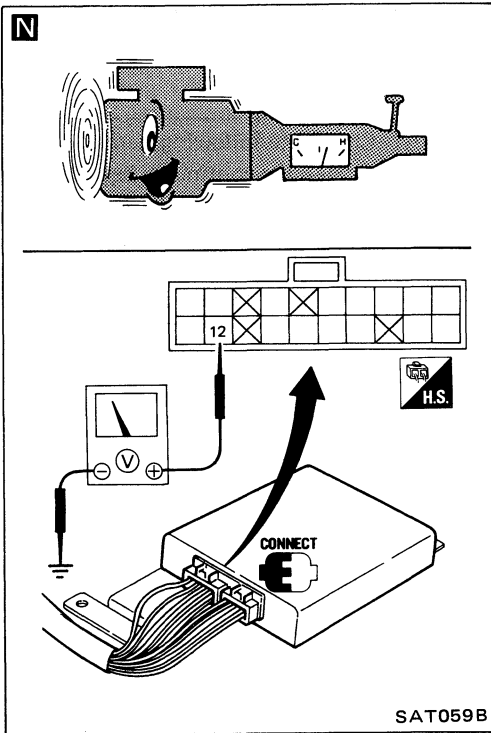

From the previous page

N

CHECK INPUT SIGNAL OF FLUID TEMPERATURE SENSOR-1

-
- Check voltage between A/T control unit terminal ⑫ and ground while warming up A/T.

Voltage:
 Cold [20°C (68°F)] →
 Hot [80°C (176°F)] :
 1.56V → 0.45V

N.G.

Check the following items.

- Harness continuity between A/T control unit and terminal cord assembly (Main harness)
- Harness continuity between terminal cord assembly and E.C.U. (Main harness)
- Ground circuit for E.C.U. — Refer to EF & EC.

O.K.

Perform self-diagnosis after driving for a while.

N.G.

1. Perform A/T control unit input/output signal inspection.
2. If N.G., recheck A/T control unit pin terminals for damage or connection of A/T control unit harness connector.

O.K.

INSPECTION END

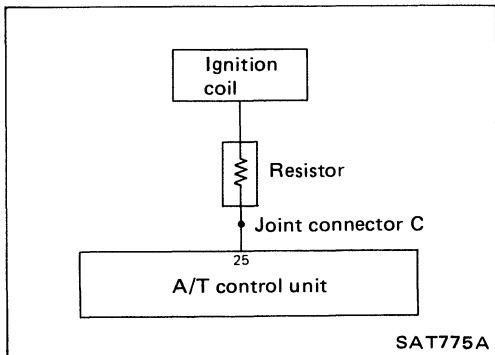

ENGINE REVOLUTION SIGNAL CIRCUIT CHECK

Perform self-diagnosis (Mode III) for engine control. Check ignition signal circuit condition.

N.G.

Check ignition signal circuit for engine control. — Refer to section EF & EC.

O.K.

CHECK INPUT SIGNAL

-
- Check voltage between A/T control unit terminal ⑫ and ground.

Voltage: 9.5 - 12V

N.G.

Check the following items.

- Harness continuity between A/T control unit and joint connector C (Main harness)
- Joint connector C

O.K.

Perform self-diagnosis again after driving for a while.

N.G.

1. Perform A/T control unit input/output signal inspection.
2. If N.G., recheck A/T control unit pin terminals for damage or connection of A/T control unit harness connector.

O.K.

INSPECTION END

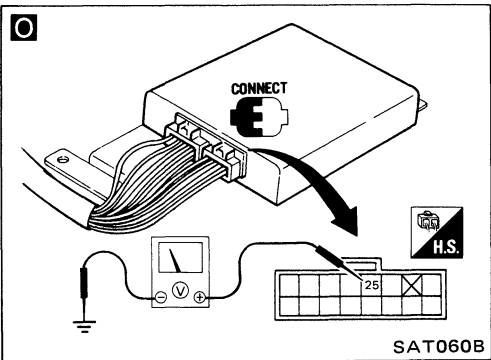

Trouble-shooting — Self-diagnosis (Cont'd)
LINE PRESSURE SOLENOID CIRCUIT CHECK

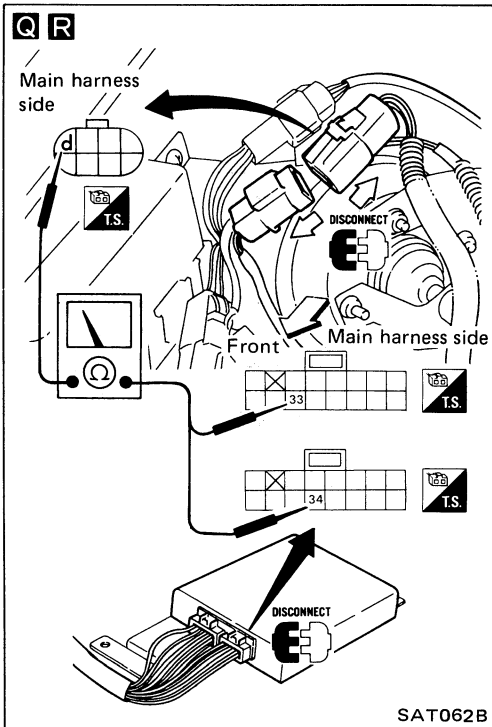
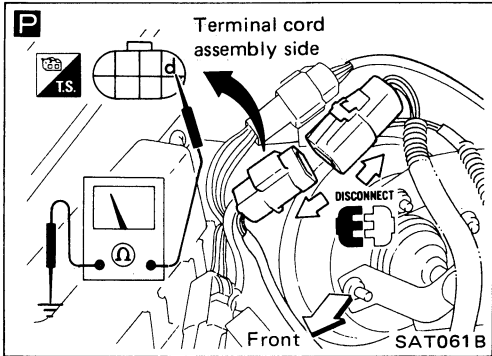
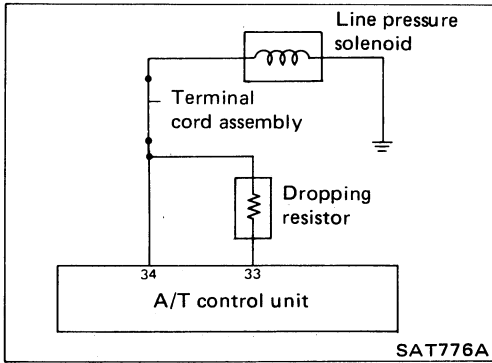

P

CHECK GROUND CIRCUIT

1. Check resistance between terminal ① and ground.
Resistance: 2.5 - 5Ω

- N.G.
1. Remove control valve assembly. — Refer to "ON-VEHICLE SERVICE".
 2. Check the following items.
 - Line pressure solenoid — Refer to "Electrical System".
 - Harness continuity of terminal cord assembly

O.K.

Q

CHECK POWER SOURCE CIRCUIT

- 1.
2. Disconnect A/T control unit 16-pin connector.
3. Check resistance between terminal ① and A/T control unit terminal ③③.
Resistance: 11.2 - 12.8Ω

- N.G.
- Check the following items.
- Dropping resistor — Refer to "Electrical System".
 - Harness continuity between A/T control unit ③③ and terminal cord assembly (Main harness)

O.K.

R

CHECK POWER SOURCE CIRCUIT

- 1.
2. Check resistance between terminal ① and A/T control unit terminal ③④.
Resistance: Approximately 0Ω
3. Reinstall any part removed.

- N.G.
- Repair or replace harness between A/T control unit ③④ and terminal cord assembly.

O.K.

Perform self-diagnosis after driving for a while.

- N.G.
1. Perform A/T control unit input/output signal inspection.
 2. If N.G., recheck A/T control unit pin terminals for damage or connection of A/T control unit harness connector.

O.K.

INSPECTION END

Trouble-shooting — Self-diagnosis (Cont'd)
 INHIBITOR, POWER SHIFT, KICKDOWN AND IDLE SWITCH CIRCUIT CHECKS

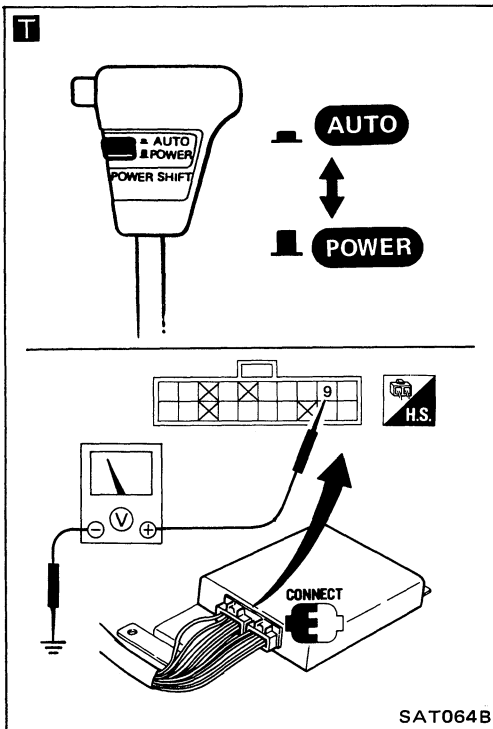
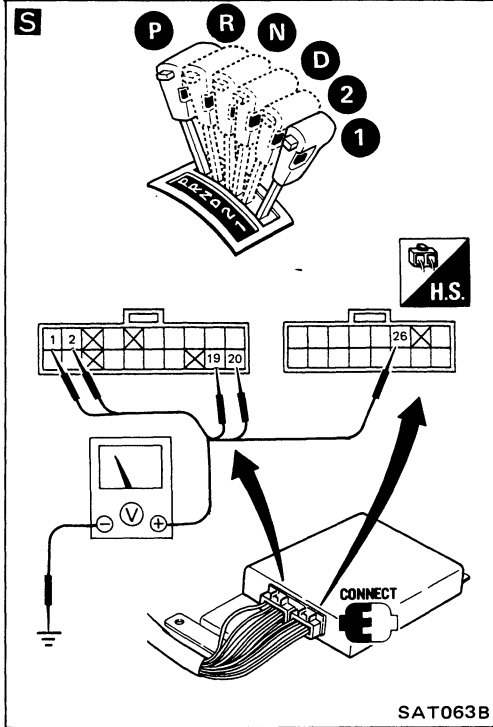
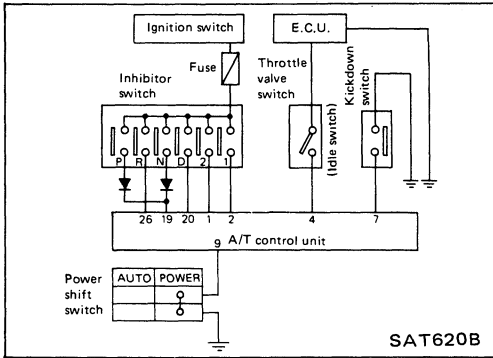

S

CHECK INHIBITOR SWITCH CIRCUIT

-
- Check voltage between A/T control unit terminals ①, ②, ⑱, ⑳, ㉔ and ground while moving selector lever through each range.

Voltage:
B: Battery voltage
0: 0V

Terminal No.	⑱	㉔	⑳	①	②
Lever position					
P, N	B	0	0	0	0
R	0	B	0	0	0
D	0	0	B	0	0
2	0	0	0	B	0
1	0	0	0	0	B

O.K.

T

CHECK POWER SHIFT SWITCH CIRCUIT

-
- Check voltage between A/T control unit terminal ⑨ and ground when power shift switch is in "AUTO" position and in "POWER" position.

Switch position	Voltage
AUTO	3 - 8V
POWER	1V or less

O.K.

To the next page

N.G.

Check the following items.

- Inhibitor switch — Refer to "Electrical System".
- Harness continuity between ignition switch and inhibitor switch (Main harness)
- Harness continuity between inhibitor switch and A/T control unit (Main harness)

N.G.

Check the following items.

- Power shift switch — Refer to "Electrical System".
- Harness continuity between A/T control unit and power shift switch (Main harness)
- Harness continuity of ground circuit for power shift switch (Main harness)

Trouble-shooting — Self-diagnosis (Cont'd)

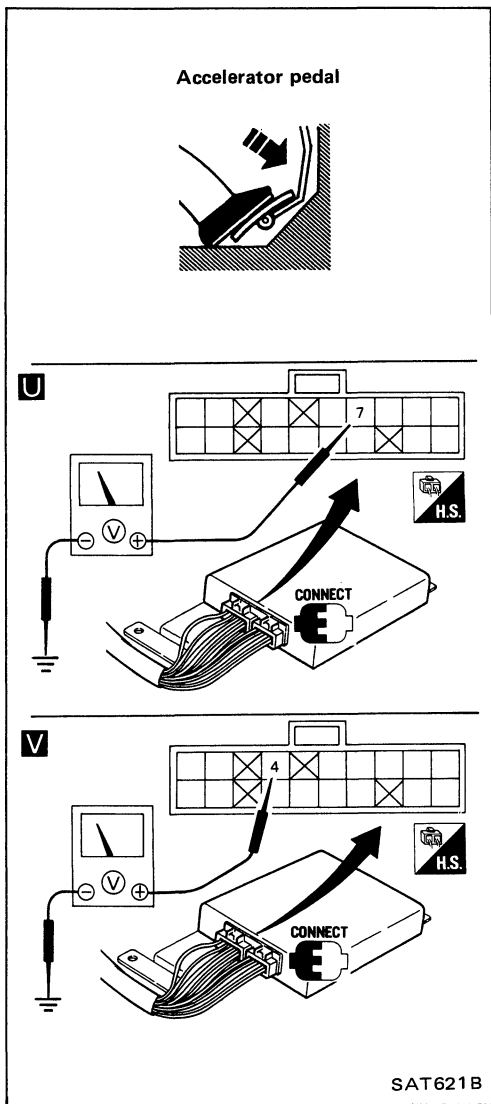

From the previous page

U

CHECK KICKDOWN SWITCH CIRCUIT

-
- Check voltage between A/T control unit terminal ⑦ and ground while depressing accelerator pedal slowly. (after warming up engine)
Voltage:
When releasing accelerator pedal: 3 - 8V
When depressing accelerator pedal fully: 1V or less

N.G.

Check the following items.

- Kickdown switch
- Harness continuity between A/T control unit and kickdown switch (Main harness)
- Harness continuity of ground circuit for kickdown switch

O.K.

V

CHECK IDLE SWITCH CIRCUIT

- Check voltage between A/T control unit terminal ④ and ground in the same way as kickdown switch circuit.
Voltage:
When releasing accelerator pedal: 8 - 15V
When depressing accelerator pedal fully: 1V or less

N.G.

Perform self-diagnosis (Mode IV) for engine control. Check idle switch circuit.

O.K.

Check harness continuity between A/T control unit and idle switch. (Main harness)

N.G.

Check idle switch circuit for engine control. — Refer to section EF & EC.

O.K.

Perform self-diagnosis again after driving for a while.

N.G.

1. Perform A/T control unit input/output signal inspection.
2. If N.G., recheck A/T control unit pin terminals for damage or connection of A/T control unit harness connector.

O.K.

INSPECTION END

Trouble-shooting

CHECK ① : Power shift indicator lamp does not come on for about 2 seconds when turning ignition switch to "ON".

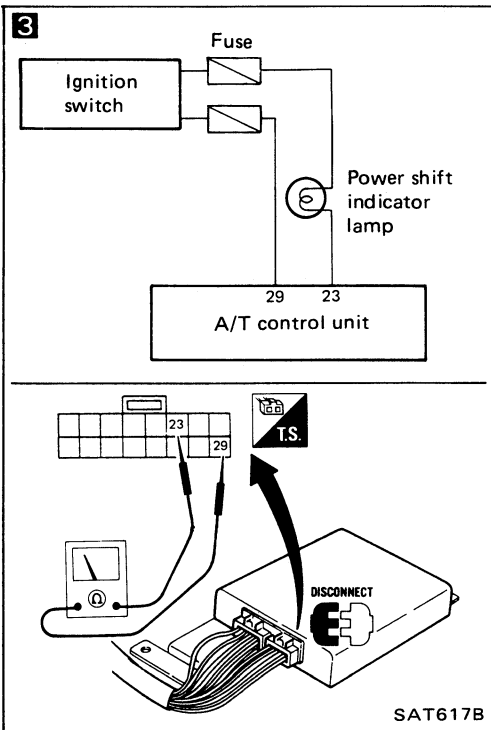
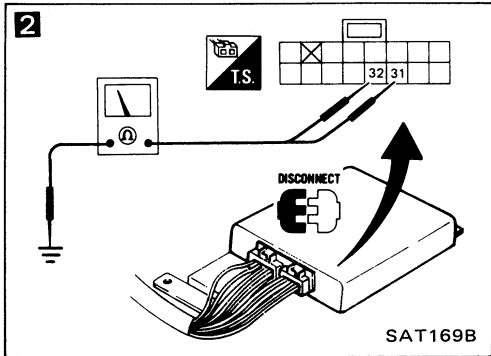
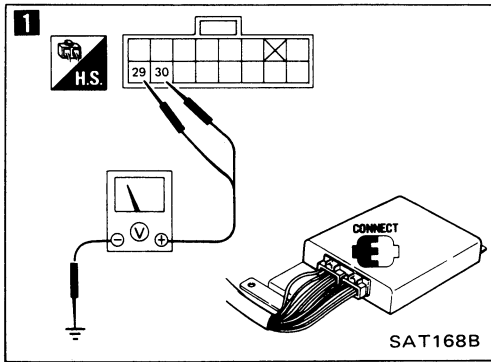

1

CHECK A/T CONTROL UNIT POWER SOURCE

-
- Check voltage between A/T control unit terminals ②⑨, ③⑩ and ground.
Battery voltage should exist.

N.G. → Check the following items.

- Harness continuity between ignition switch and A/T control unit (Main harness)
- Ignition switch and fuse – Refer to section EL.

O.K. ↓

2

CHECK A/T CONTROL UNIT GROUND CIRCUIT

-
- Disconnect A/T control unit 16-pin connector.
- Check resistance between A/T control unit terminals ③①, ③② and ground.
Resistance: Approximately 0Ω

N.G. → Check harness continuity between A/T control unit and ground.

O.K. ↓

3

CHECK LAMP CIRCUIT

-
- Disconnect A/T control unit 16-pin connector.
- Check resistance between A/T control unit terminals ②③ and ②⑨.
Resistance: 50 - 100Ω
- Reinstall any part removed.

N.G. → Check the following items.

- Power shift indicator lamp – Refer to section EL.
- Harness continuity between ignition switch and power shift indicator lamp (Main harness)
- Harness continuity between power shift indicator lamp and A/T control unit

O.K. ↓

Check again.

N.G. →

1. Perform A/T control unit input/output signal inspection.
2. If N.G., recheck A/T control unit pin terminals for damage or connection of A/T control unit harness connector.

O.K. ↓

INSPECTION END

Trouble-shooting (Cont'd)

CHECK ② : A/T indicator lamp on instrument panel, in response to selector lever position does not come on or other range indicator lamp comes on.

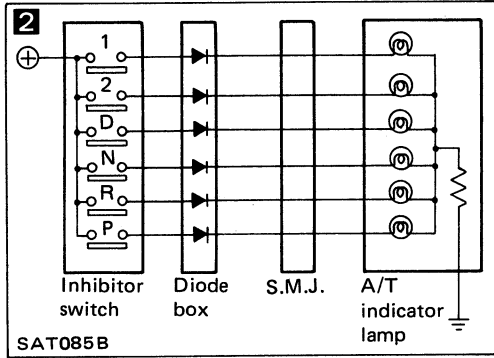
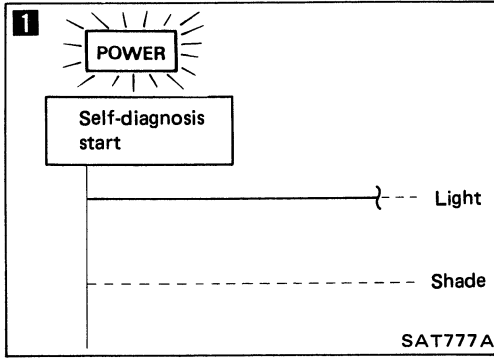

1

Does self-diagnosis show damage to inhibitor switch circuit?

- Yes → Check inhibitor switch circuit. — Refer to "Self-diagnosis".
- No → **2**

2

Check the following items. — Refer to section EL.

- A/T indicator lamp
- Diode box
- S.M.J.
- Harness continuity between inhibitor switch and A/T indicator lamp (Main harness)

- N.G. → Repair or replace damaged parts.
- O.K. → **INSPECTION END**

Trouble-shooting (Cont'd)

CHECK ③ : Power shift indicator lamp does not come on for about 3 seconds when depressing and releasing accelerator pedal fully.

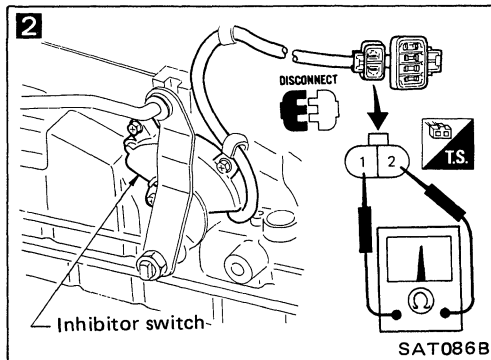
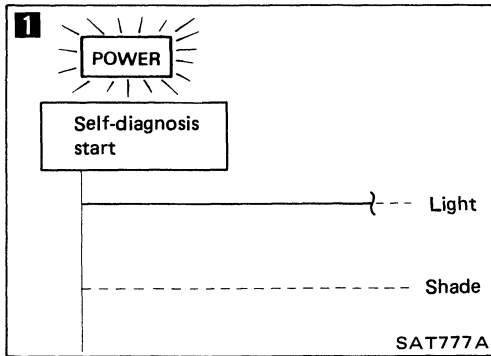
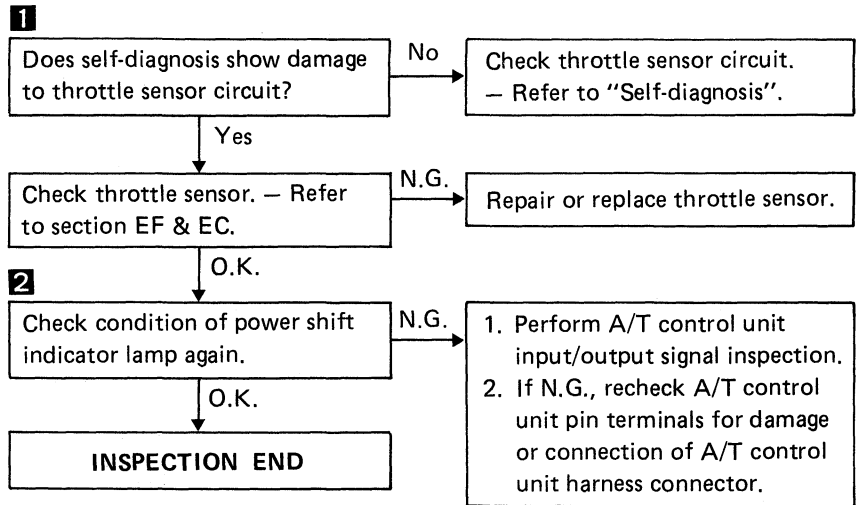
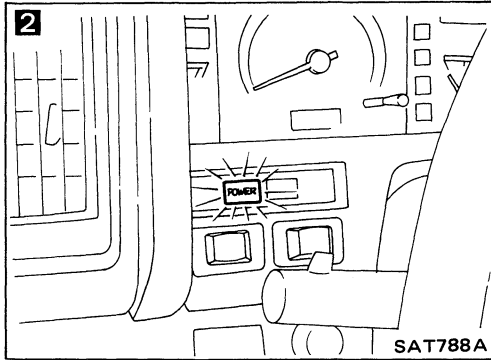
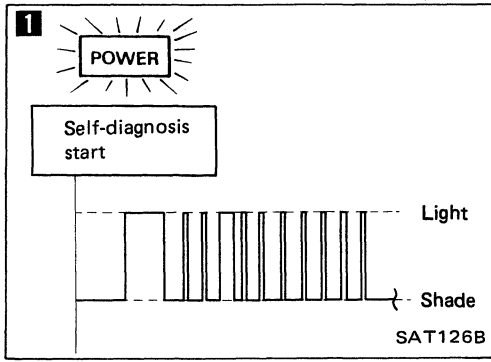

CHECK ④ : Engine cannot be started with selector lever in "P" or "N" range or engine can be started with selector lever in "D", "2", "1" or "R" range.

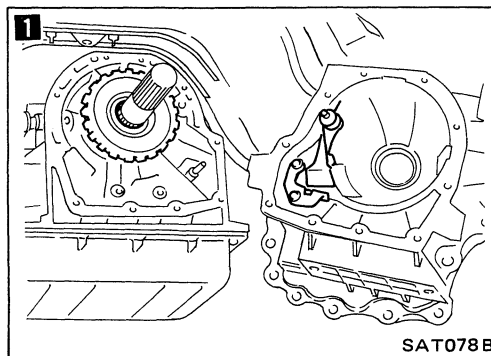
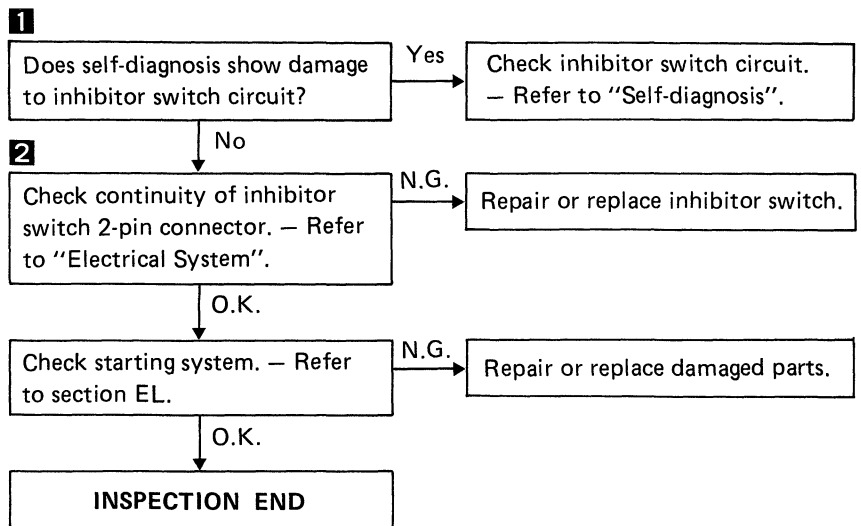

CHECK ⑤ : Vehicle moves when it is pushed forward or backward with selector lever in "P" range.

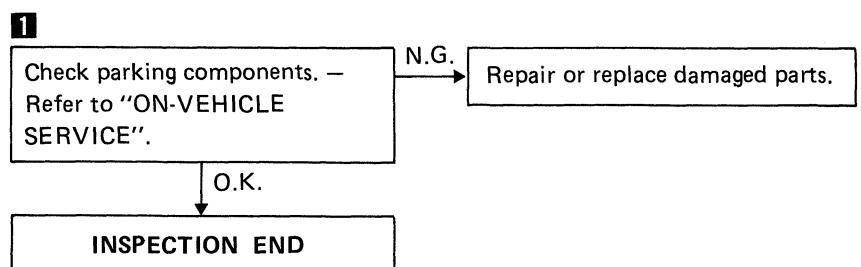

Trouble-shooting (Cont'd)

CHECK ⑥ : Vehicle moves forward or backward when selecting "N" range.

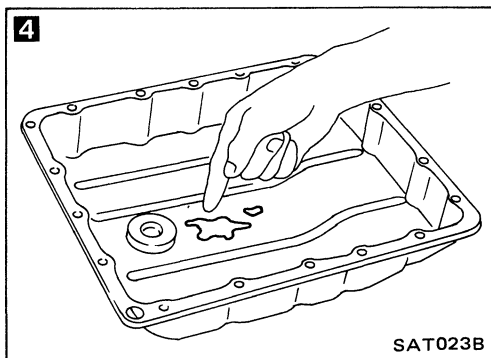
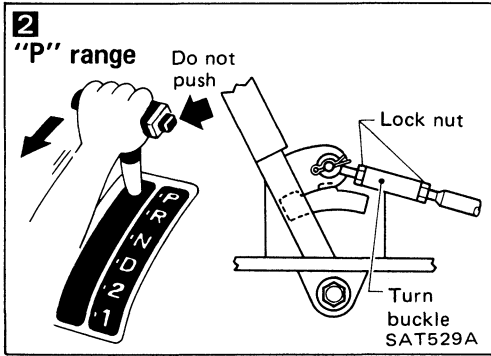
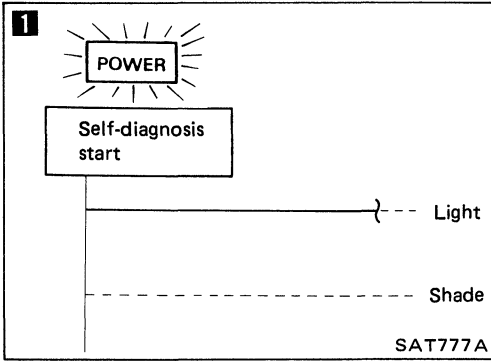

```

    graph TD
        Q1[1 Does self-diagnosis show damage to inhibitor switch after cruise test?] -- Yes --> A1[Check inhibitor switch circuit. - Refer to "Self-diagnosis".]
        Q1 -- No --> Q2[2 Check manual control linkage. - Refer to ON-VEHICLE SERVICE.]
        Q2 -- N.G. --> A2[Adjust manual control linkage. - Refer to ON-VEHICLE SERVICE.]
        Q2 -- O.K. --> Q3[3 Check A/T fluid level again.]
        Q3 -- N.G. --> A3[Refill A.T.F.]
        Q3 -- O.K. --> Q4[4 1. Remove oil pan. 2. Check A/T fluid condition.]
        Q4 -- N.G. --> A4[1. Disassemble A/T. 2. Check the following items. • Forward clutch assembly • Overrun clutch assembly • Reverse clutch assembly • Accumulator piston D]
        Q4 -- O.K. --> Q5[Check again.]
        Q5 -- N.G. --> A5[1. Perform A/T control unit input/output signal inspection. 2. If N.G., recheck A/T control unit pin terminals for damage or connection of A/T control unit harness connector.]
    
```

Trouble-shooting (Cont'd)

CHECK ⑦: There is large shock when changing from "N" to "R" range.

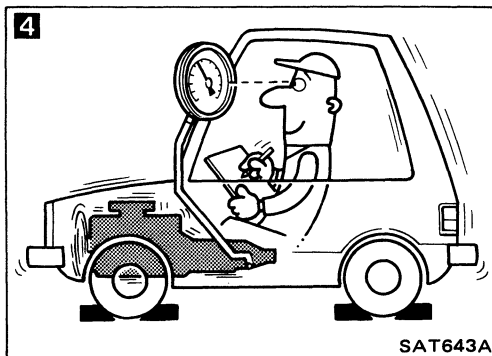
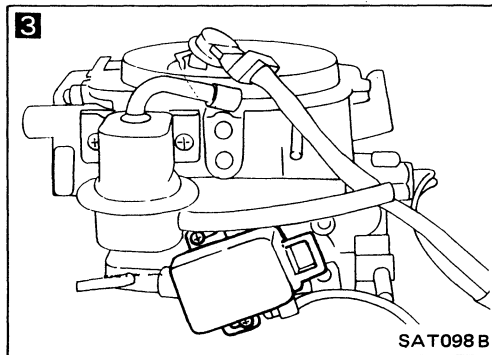
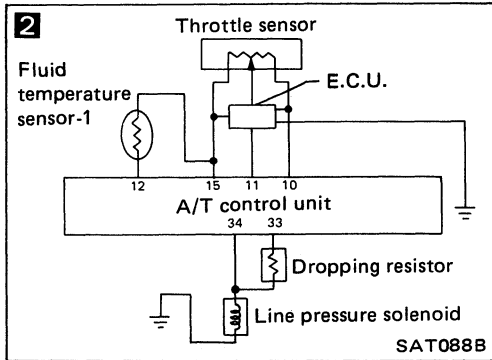
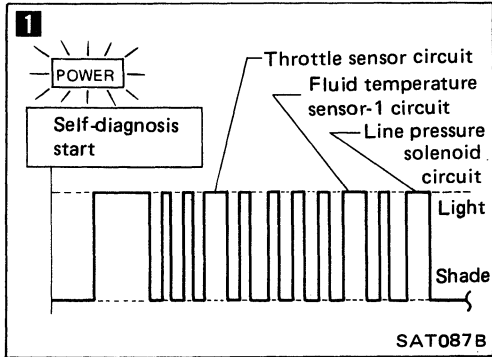

```

    graph TD
        Q1[1 Does self-diagnosis show damage to throttle sensor, line pressure solenoid or fluid temperature sensor-1 circuit?] -- Yes --> A2[2 Check damaged circuit. — Refer to "Self-diagnosis".]
        Q1 -- No --> Q3[3 Check throttle sensor. — Refer to section EF & EC.]
        Q3 -- N.G. --> A3[Repair or replace throttle sensor.]
        Q3 -- O.K. --> Q4[4 Check line pressure at idle with selector lever in "D" range. — Refer to "Pressure Testing".]
        Q4 -- N.G. --> A4[1. Remove control valve assembly. — Refer to "ON-VEHICLE SERVICE".  
2. Check the following items.  
• Valves to control line pressure (Pressure regulator valve, modifier valve, pilot valve and pilot filter)  
• Line pressure solenoid]
        Q4 -- O.K. --> Q5[Check again.]
        Q5 -- N.G. --> A5[1. Perform A/T control unit input/output signal inspection.  
2. If N.G., recheck A/T control unit pin terminals for damage or connection of A/T control unit harness connector.]
        Q5 -- O.K. --> END[INSPECTION END]
    
```

Trouble-shooting (Cont'd)

CHECK ⑧ : Vehicle does not creep backward when selecting "R" range.

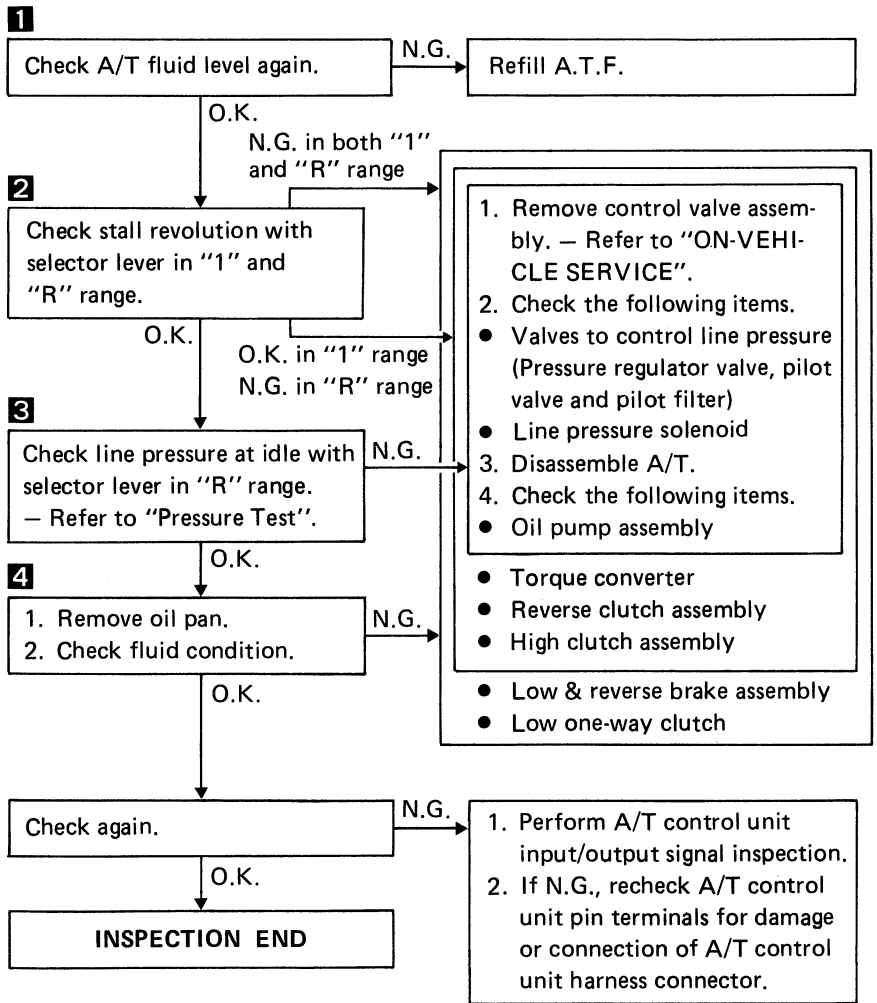
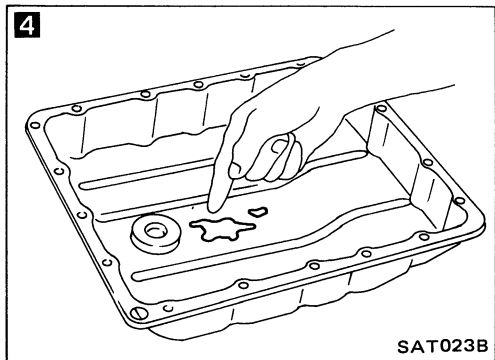
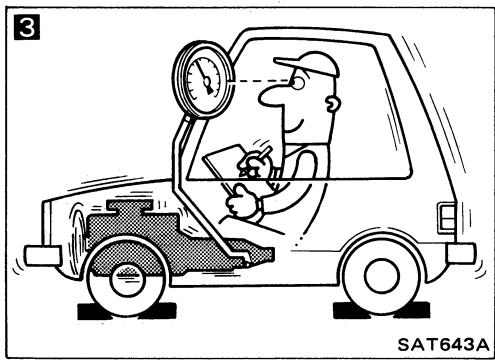
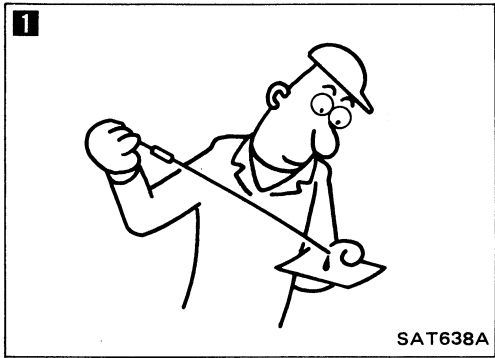

Trouble-shooting (Cont'd)

CHECK ⑨: Vehicle does not creep forward when selecting "D" and "2" ranges.

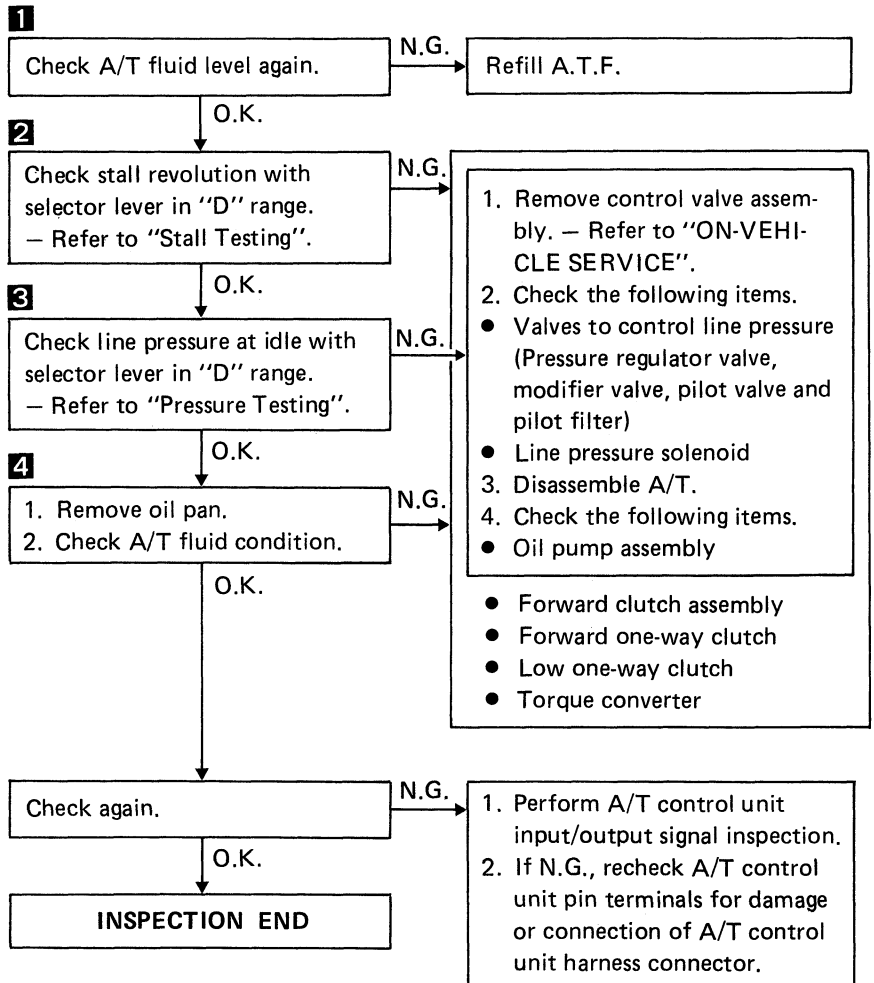
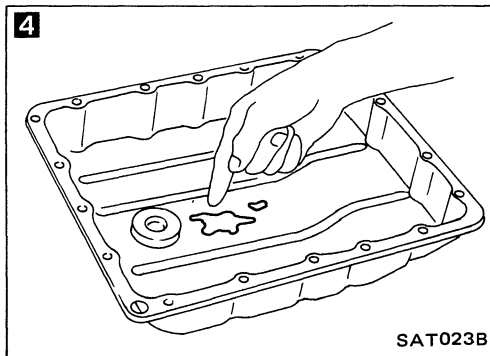
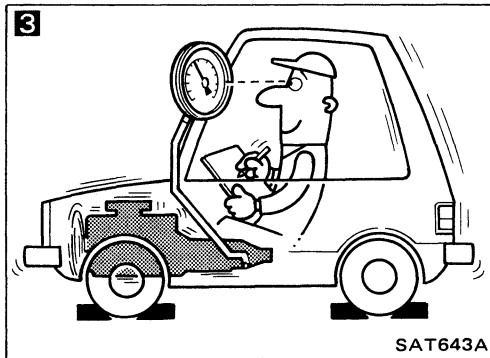
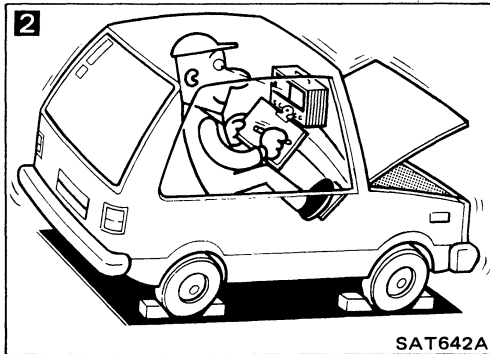
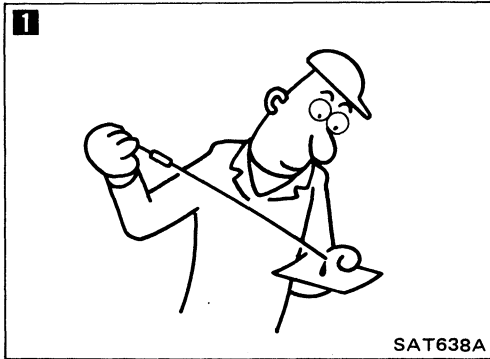

Trouble-shooting (Cont'd)

CHECK ⑩ : Vehicle does not creep forward when selecting "D", "2" and "1" range.

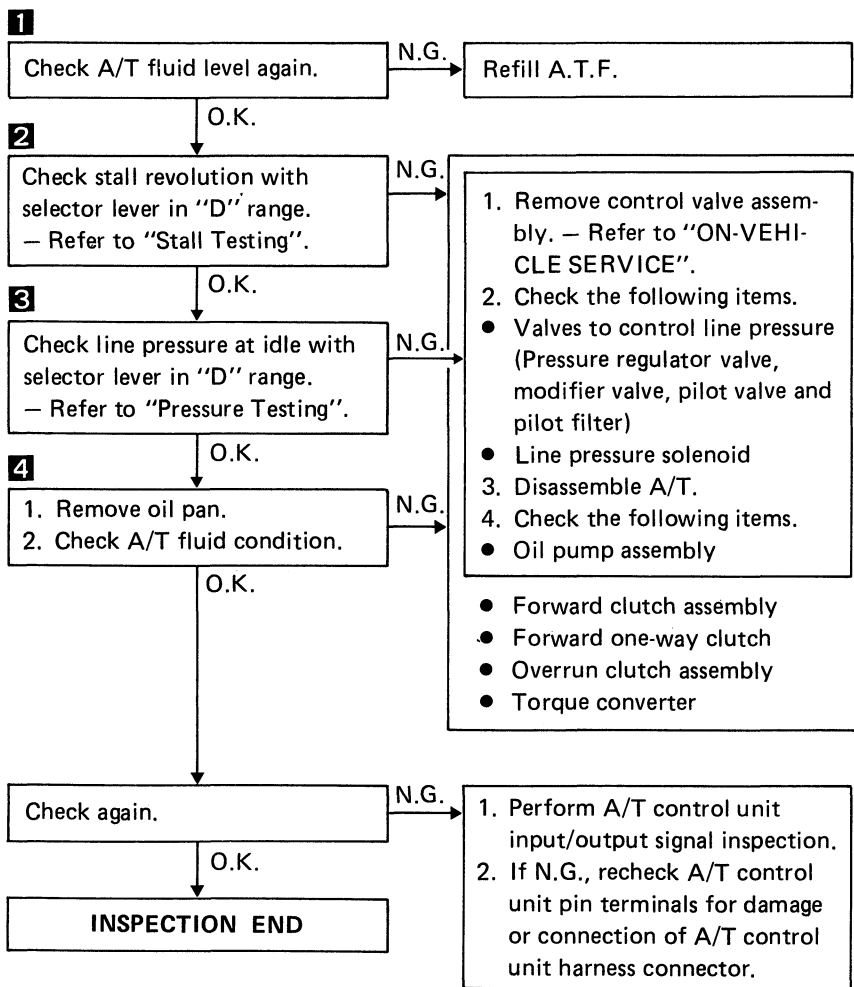
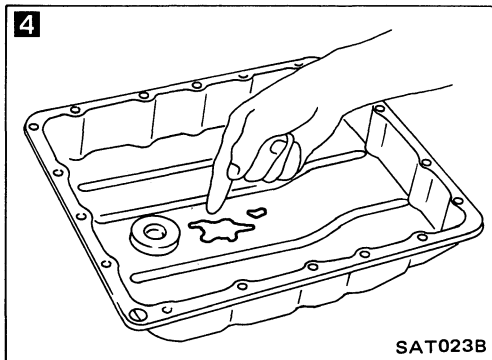
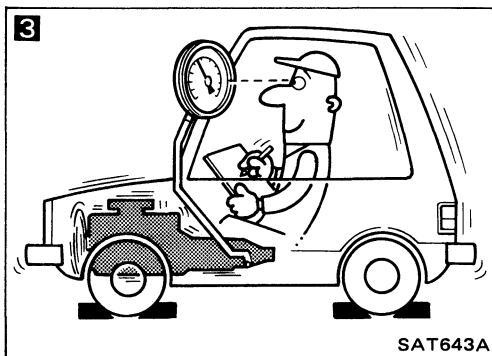
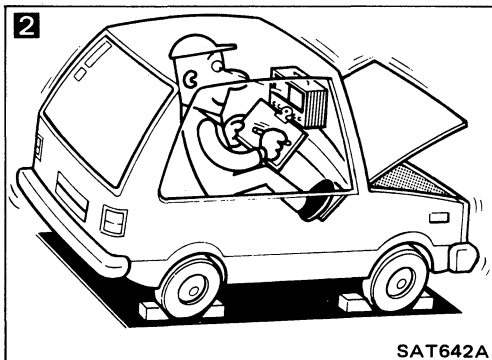
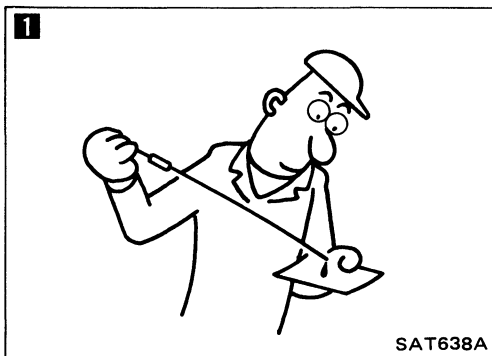

Trouble-shooting (Cont'd)

CHECK ⑪ : Vehicle cannot be started from D₁ on CRUISE TEST — Part 1.

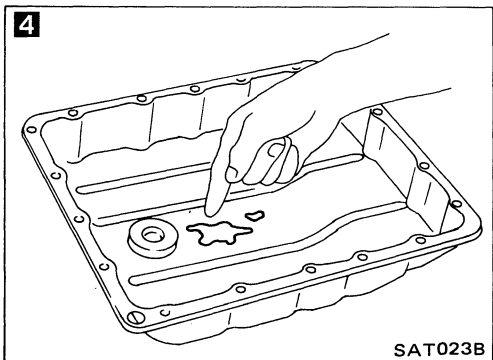
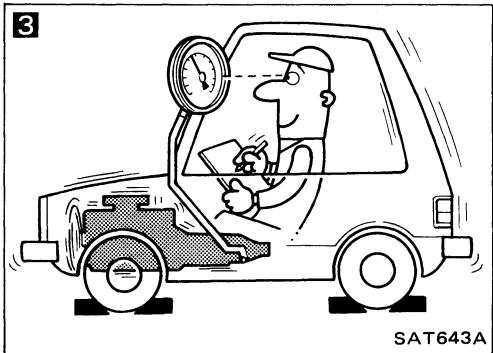
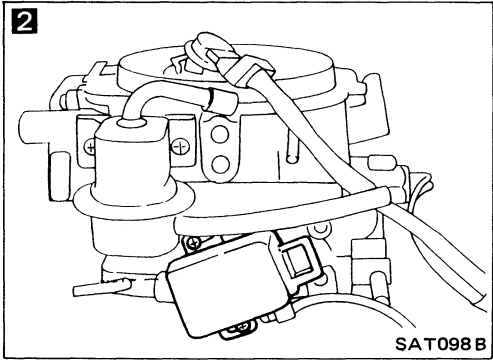
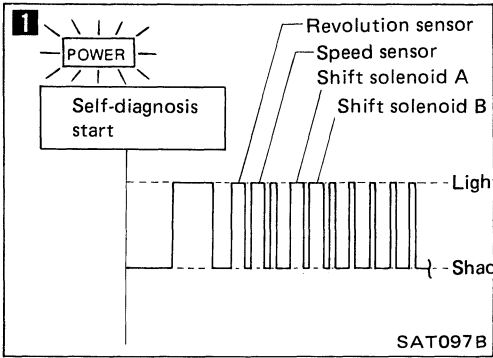

```

    graph TD
        Q1{Are checks 9 and 10 O.K.?} -- No --> A1[Go to check 9 or 10.]
        Q1 -- Yes --> Q2{Does self-diagnosis show damage to revolution sensor, speed sensor, shift solenoid A or B after cruise test?}
        Q2 -- Yes --> A2[Check damaged circuit. — Refer to "Self-diagnosis".]
        Q2 -- No --> Q3{Check throttle sensor. — Refer to section EF & EC.}
        Q3 -- N.G. --> A3[Repair or replace throttle sensor.]
        Q3 -- O.K. --> Q4{Check line pressure at stall point with selector lever in "D" range. — Refer to "Pressure Testing".}
        Q4 -- N.G. --> A4[1. Remove control valve assembly. — Refer to "ON-VEHICLE SERVICE".  
2. Check the following items.  
• Shift valve A  
• Shift valve B  
• Shift solenoid A  
• Shift solenoid B  
• Pilot valve  
• Pilot filter]
        Q4 -- O.K. --> Q5{1. Remove oil pan.  
2. Check A/T fluid condition.}
        Q5 -- O.K. --> A5[3. Disassemble A/T.  
4. Check the following items.  
• Forward clutch assembly  
• Forward one-way clutch  
• Low one-way clutch  
• High clutch assembly  
• Torque converter  
• Oil pump assembly]
        Q5 -- N.G. --> A4
        A4 -- O.K. --> A5
        A5 -- O.K. --> A6[Check again.]
        A6 -- N.G. --> A7[1. Perform A/T control unit input/output signal inspection.  
2. If N.G., recheck A/T control unit pin terminals for damage or connection of A/T control unit harness connector.]
        A6 -- O.K. --> A8[INSPECTION END]
    
```

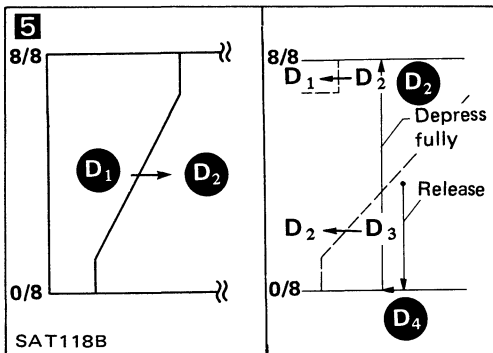
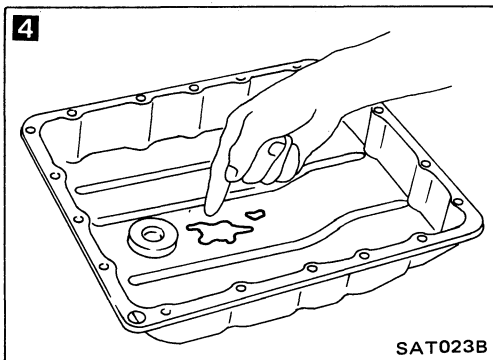
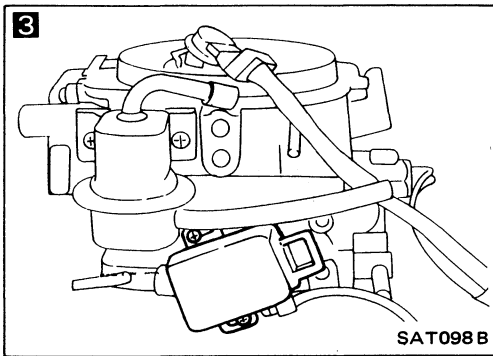
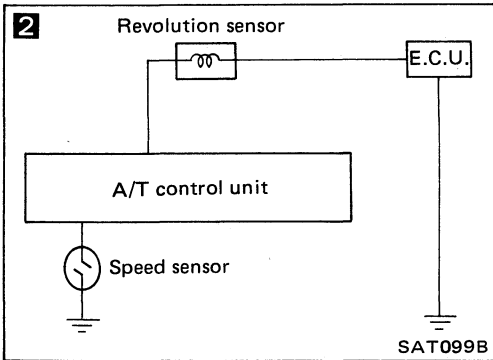
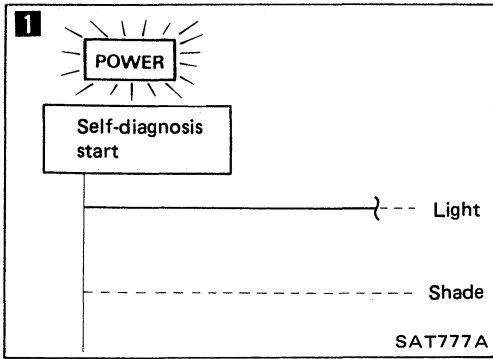

Trouble-shooting (Cont'd)

CHECK ⑫: A/T does not shift from D₁ to D₂ at the specified speed.

A/T does not shift from D₄ to D₂ when depressing accelerator pedal fully at the specified speed.

```

    graph TD
        Q1{Are checks 9, 10 and 11 O.K.?} -- No --> A1[Go to check 9, 10 or 11.]
        Q1 -- Yes --> Q2{Does self-diagnosis show damage to inhibitor switch after cruise test?}
        Q2 -- Yes --> A2[Check inhibitor switch circuit. - Refer to "Self-diagnosis".]
        Q2 -- No --> Q3{Check revolution sensor and speed sensor circuit. - Refer to "Self-diagnosis".}
        Q3 -- N.G. --> A3[Repair or replace revolution sensor and speed sensor circuits.]
        Q3 -- O.K. --> Q4{Check throttle sensor. - Refer to section EF & EC.}
        Q4 -- N.G. --> A4[Repair or replace throttle sensor.]
        Q4 -- O.K. --> Q5{1. Remove oil pan.  
2. Check A/T fluid condition.}
        Q5 -- N.G. --> A5[1. Remove control valve. - Refer to "ON-VEHICLE SERVICE".  
2. Check the following items:  
• Shift valve A  
• Shift solenoid A  
• Pilot valve  
• Pilot filter]
        Q5 -- O.K. --> A5
        A5 -- O.K. --> Q6{3. Disassemble A/T.  
4. Check the following items:  
• Servo piston assembly  
• Brake band  
• Oil pump assembly}
        Q6 -- O.K. --> A5
        Q6 -- N.G. --> Q7{Check again.}
        Q7 -- N.G. --> A6[1. Perform A/T control unit input/output signal inspection.  
2. If N.G., recheck A/T control unit pin terminals for damage or connection of A/T control unit harness connector.]
        Q7 -- O.K. --> END[INSPECTION END]
    
```

Trouble-shooting (Cont'd)

CHECK ⑬: A/T does not shift from D₂ to D₃ at the specified speed.

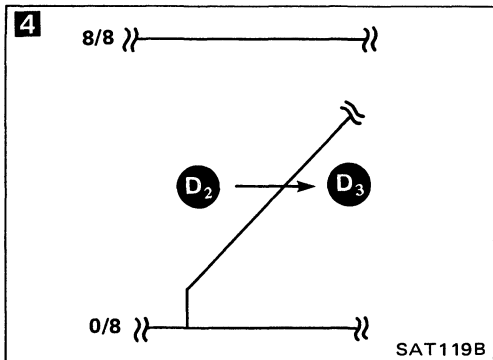
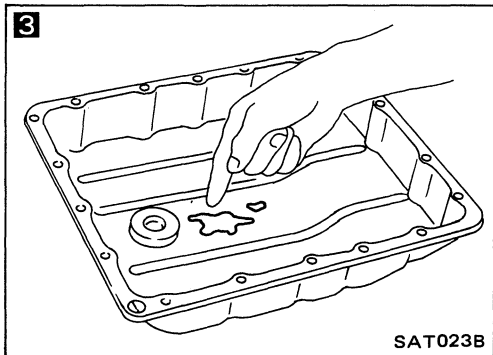
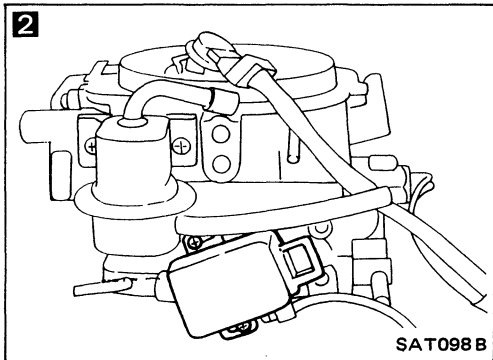
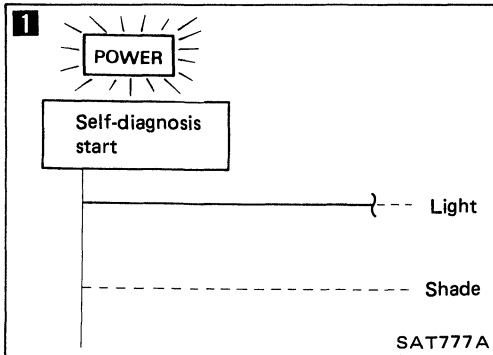

```

    graph TD
        Q1[Are checks ⑨, ⑩ and ⑪ O.K.?] -- No --> A1[Go to check ⑨, ⑩ or ⑪.]
        Q1 -- Yes --> Q2[Does self-diagnosis show damage to inhibitor switch after cruise test?]
        Q2 -- Yes --> A2[Check inhibitor switch circuit. - Refer to "Self-diagnosis".]
        Q2 -- No --> Q3[Check throttle sensor. - Refer to section EF & EC.]
        Q3 -- N.G. --> A3[Repair or replace throttle sensor.]
        Q3 -- O.K. --> Q4[1. Remove oil pan.  
2. Check A/T fluid condition.]
        Q4 -- N.G. --> A4[1. Remove control valve assembly. - Refer to "ON-VEHICLE SERVICE".  
2. Check the following items:  
• Shift valve B  
• Shift solenoid B  
• Pilot valve  
• Pilot filter  
3. Disassemble A/T.  
4. Check the following items:  
• Servo piston assembly  
• High clutch assembly  
• Oil pump assembly]
        Q4 -- O.K. --> A4
        A4 -- O.K. --> Q5[Check again.]
        Q5 -- N.G. --> A5[1. Perform A/T control unit input/output signal inspection.  
2. If N.G., recheck A/T control unit pin terminals for damage or connection of A/T control unit harness connector.]
        Q5 -- O.K. --> A6[INSPECTION END]
    
```

Trouble-shooting (Cont'd)

CHECK 14 : A/T does not shift from D₃ to D₄ at the specified speed.

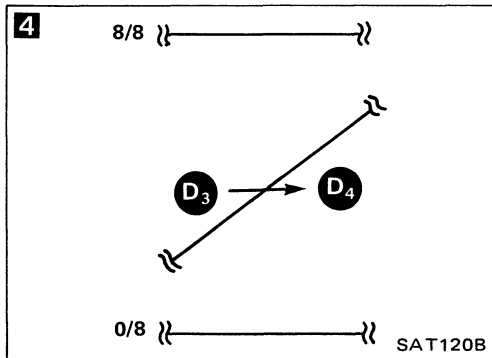
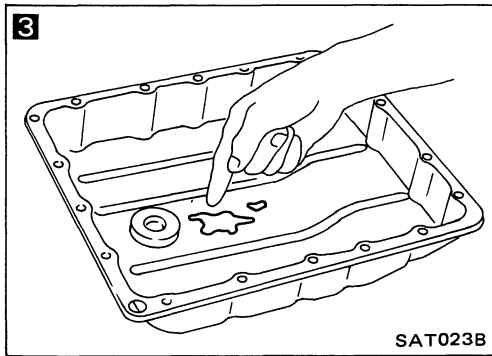
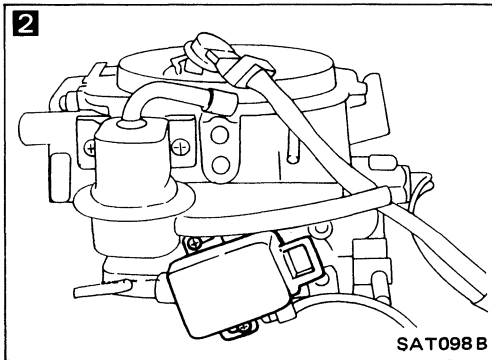
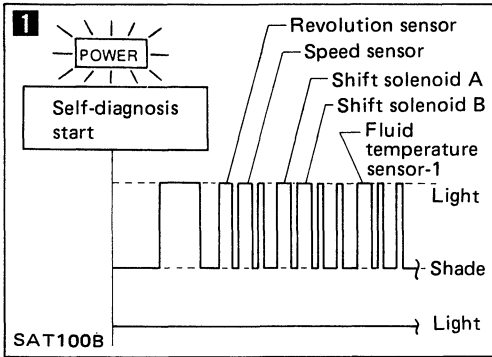

Are checks 9, 10 and 11 O.K.? No → Go to check 9, 10 or 11.

Yes
 1 Does self-diagnosis show damage to inhibitor switch, power shift switch, shift solenoid A, B, revolution sensor, speed sensor or fluid temperature sensor-1 circuit after cruise test? Yes → Check damaged circuit. — Refer to "Self-diagnosis".

No
 2 Check throttle sensor. — Refer to section EF & EC. N.G. → Repair or replace throttle sensor.

O.K.
 3 1. Remove oil pan.
 2. Check A/T fluid condition. N.G. →

1. Remove control valve assembly. — Refer to "ON-VEHICLE SERVICE".

2. Check the following items.

- Shift valve B
- Overrun clutch control valve
- Shift solenoid B
- Pilot valve
- Pilot filter

3. Disassemble A/T.

4. Check the following items.

- Servo piston assembly
- Brake band
- Torque converter
- Oil pump assembly

O.K. →

O.K. →

O.K. →

4 Check again. N.G. →

1. Perform A/T control unit input/output signal inspection.

2. If N.G., recheck A/T control unit pin terminals for damage or connection of A/T control unit harness connector.

O.K. →

INSPECTION END

Trouble-shooting (Cont'd)

CHECK ⑮: A/T does not perform lock-up at the specified speed.

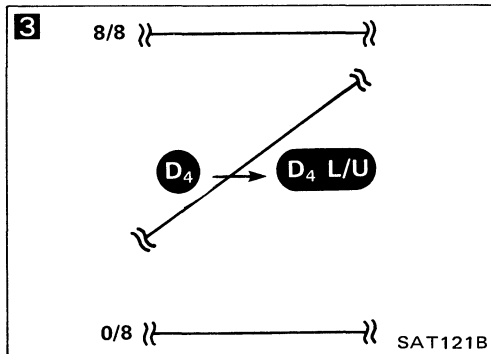
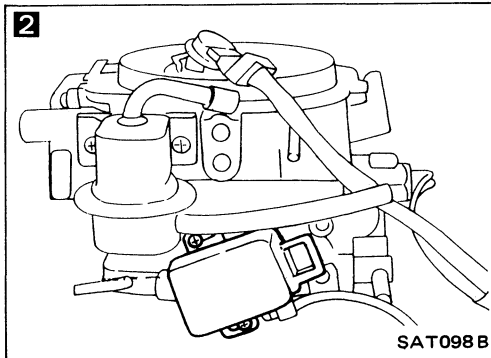
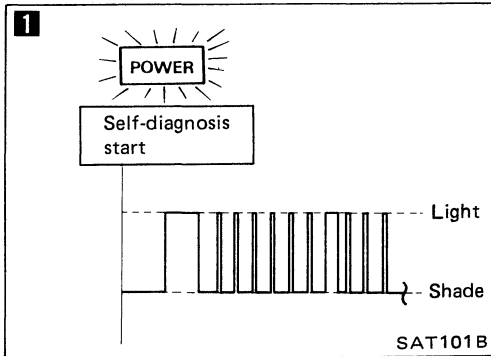

```

    graph TD
        Q1[1 Does self-diagnosis show damage to lock-up solenoid circuit after cruise test?] -- Yes --> A1[Check lock-up solenoid circuit. - Refer to "Self-diagnosis".]
        Q1 -- No --> Q2[2 Check throttle sensor. - Refer to section EF & EC.]
        Q2 -- N.G. --> A2[Repair or replace throttle sensor.]
        Q2 -- O.K. --> Q3[3 1. Remove control valve. - Refer to "ON-VEHICLE SERVICE".  
2. Check following items.  
• Lock-up control valve  
• Shuttle shift valve D  
• Torque converter relief valve  
• Lock-up solenoid  
• Pilot valve  
• Pilot filter]
        Q3 -- N.G. --> A3[Repair or replace damaged parts.]
        Q3 -- O.K. --> Q4[Check again.]
        Q4 -- N.G. --> A4[1. Perform A/T control unit input/output signal inspection.  
2. If N.G., recheck A/T control unit pin terminals for damage or connection of A/T control unit harness connector.]
        Q4 -- O.K. --> END[INSPECTION END]
    
```

Trouble-shooting (Cont'd)

CHECK ⑯ : A/T does not hold lock-up condition for more than 30 seconds.

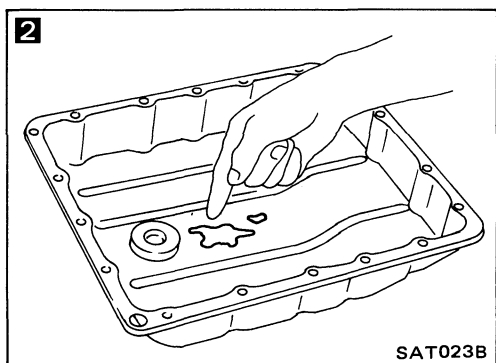
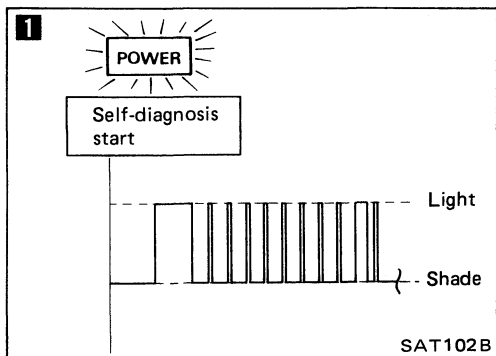

```

    graph TD
        Q1[1 Does self-diagnosis show damage to engine revolution signal circuit after cruise test?] -- Yes --> A1[Check revolution sensor circuit. - Refer to "Self-diagnosis".]
        Q1 -- No --> Q2[2 1. Remove oil pan. 2. Check A/T fluid condition.]
        Q2 -- O.K. --> Q3[Check again.]
        Q2 -- N.G. --> A2[1. Remove control valve assembly. - Refer to "ON-VEHICLE SERVICE". 2. Check the following items. • Lock-up control valve • Pilot valve • Pilot filter 3. Disassemble A/T. 4. Check torque converter and oil pump assembly.]
        A2 -- O.K. --> Q3
        A2 -- O.K. --> Q3
        Q3 -- N.G. --> A3[1. Perform A/T control unit input/output signal inspection. 2. If N.G., recheck A/T control unit pin terminals for damage or connection of A/T control unit harness connector.]
        Q3 -- O.K. --> END[INSPECTION END]
    
```

CHECK ⑰ : Lock-up is not released when accelerator pedal is released.

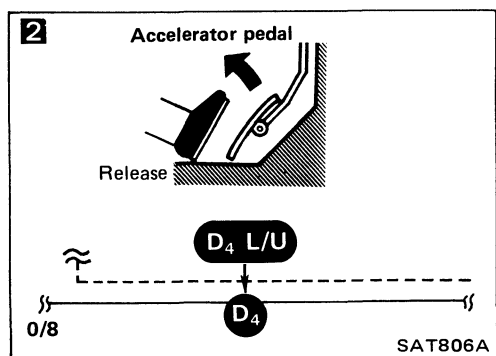
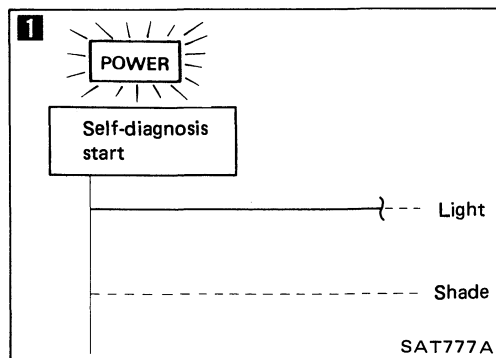

```

    graph TD
        Q1[1 Does self-diagnosis show damage to idle switch circuit after cruise test?] -- Yes --> A1[Check idle switch circuit. - Refer to "Self-diagnosis".]
        Q1 -- No --> Q2[2 Check again.]
        Q2 -- O.K. --> END[INSPECTION END]
        Q2 -- N.G. --> A2[1. Perform A/T control unit input/output signal inspection. 2. If N.G., recheck A/T control unit pin terminals for damage or connection of A/T control unit harness connector.]
    
```

Trouble-shooting (Cont'd)

CHECK ⑱ : Engine speed does not return to idle smoothly when A/T is shifted from D₄ to D₃ with accelerator pedal released.
 Vehicle does not decelerate by engine brake when setting "POWER" position with accelerator pedal released.
 Vehicle does not decelerate by engine brake when moving selector lever from "D" to "2" range with accelerator pedal released.

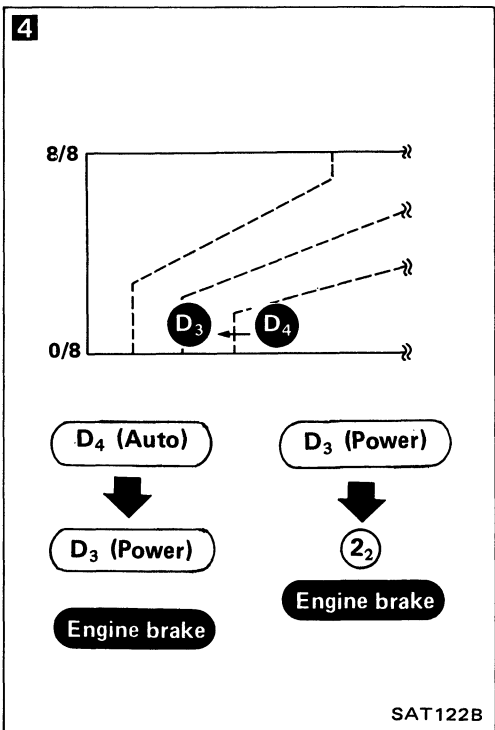
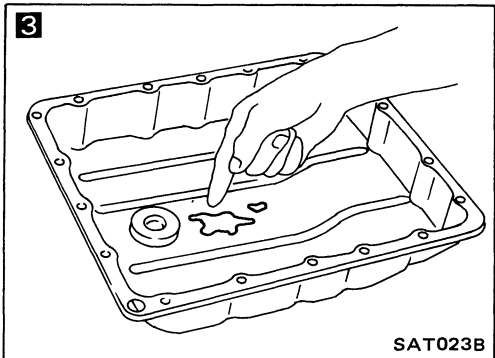
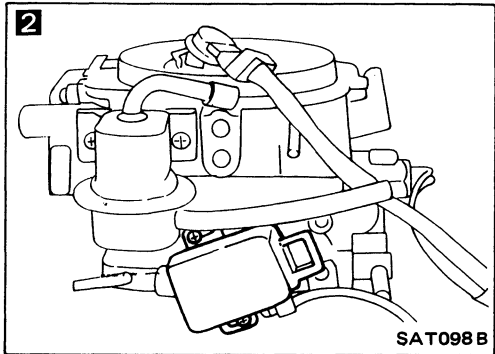
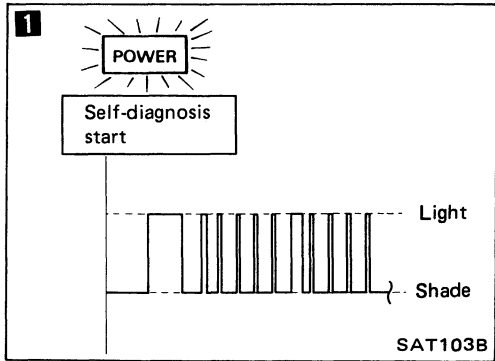

```

    graph TD
        Q1[1. Does self-diagnosis show damage to overrun clutch solenoid circuit after cruise test?] -- Yes --> A1[Check overrun clutch solenoid circuit. — Refer to "Self-diagnosis".]
        Q1 -- No --> Q2[2. Check throttle sensor. — Refer to section EF & EC.]
        Q2 -- N.G. --> A2[Repair or replace throttle sensor.]
        Q2 -- O.K. --> Q3[3. 1. Remove oil pan.  
2. Check A/T fluid condition.]
        Q3 -- N.G. --> A3[1. Remove control valve assembly. — Refer to "ON-VEHICLE SERVICE".  
2. Check the following items:  
• Overrun clutch control valve  
• Overrun clutch reducing valve  
• Overrun clutch solenoid]
        Q3 -- O.K. --> A4[3. Disassemble A/T.  
4. Check the following items:  
• Overrun clutch assembly  
• Oil pump assembly]
        A3 --> Q4[4. Check again.]
        A4 --> Q4
        Q4 -- N.G. --> A5[1. Perform A/T control unit input/output signal inspection.  
2. If N.G., recheck A/T control unit pin terminals for damage or connection of A/T control unit harness connector.]
        Q4 -- O.K. --> END[INSPECTION END]
    
```

Trouble-shooting (Cont'd)

CHECK ⑱ : Vehicle does not start from D₁ on CRUISE TEST
 — Part 2.

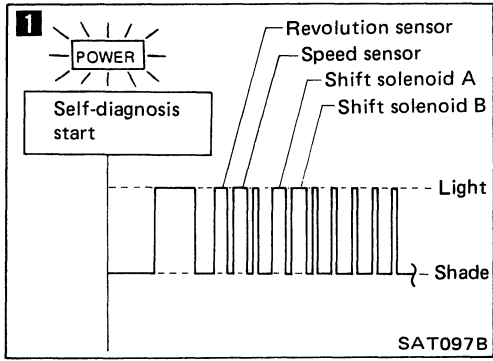

1

```

    graph TD
        Q1{Does self-diagnosis show damage to revolution sensor, speed sensor, shift solenoid A or B after cruise test?}
        Q1 -- Yes --> A1[Check damaged circuit. — Refer to "Self-diagnosis".]
        Q1 -- No --> Q2{Check again.}
        Q2 -- N.G. --> A2[1. Perform A/T control unit input/output signal inspection.  
2. If N.G., recheck A/T control unit pin terminals for damage or connection of A/T control unit harness connector.]
        Q2 -- O.K. --> A3[Go to CHECK ⑲.]
    
```

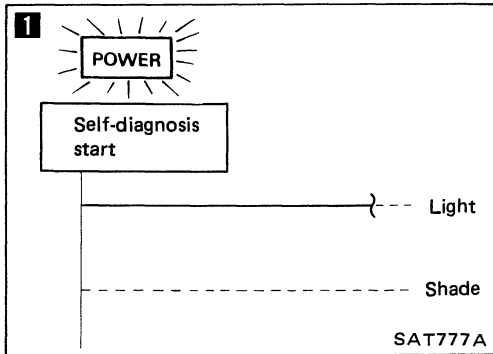

CHECK ⑳ : A/T does not shift from D₄ to D₃ when changing power shift switch to "POWER" position.

1

```

    graph TD
        Q1{Does self-diagnosis show damage to power shift switch circuit after cruise test?}
        Q1 -- Yes --> A1[Check power shift switch circuit. — Refer to "Self-diagnosis".]
        Q1 -- No --> A2[Go to CHECK ⑬.]
    
```

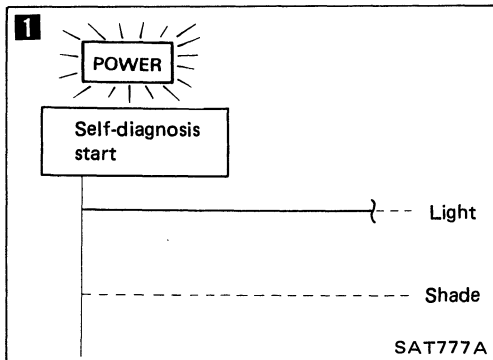

CHECK ㉑ : A/T does not shift from D₃ to 2₂ when changing selector lever position from "D" to "2" range.

1

```

    graph TD
        Q1{Does self-diagnosis show damage to inhibitor switch circuit after cruise test?}
        Q1 -- Yes --> A1[Check inhibitor switch circuit. — Refer to "Self-diagnosis".]
        Q1 -- No --> A2[Go to CHECK ⑫.]
    
```

Trouble-shooting (Cont'd)

CHECK 22 : A/T does not shift from 2₂ to 1₁ when changing selector lever position from "2" to "1" range.

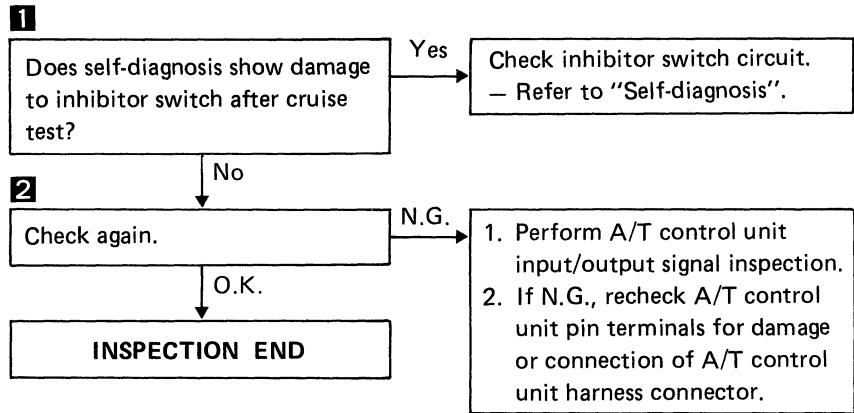
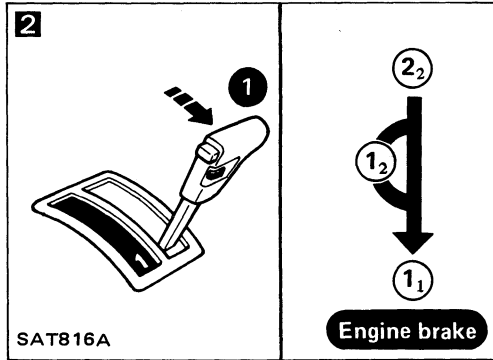
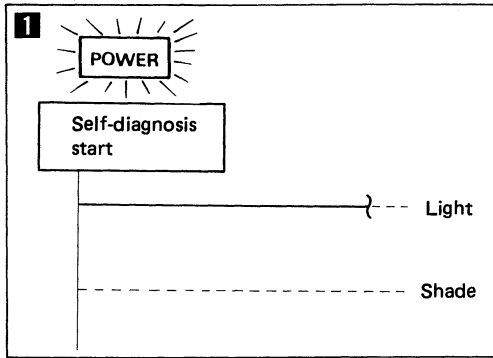

CHECK 23 : Vehicle does not decelerate by engine brake when shifting from 2₂ (1₂) to 1₁.

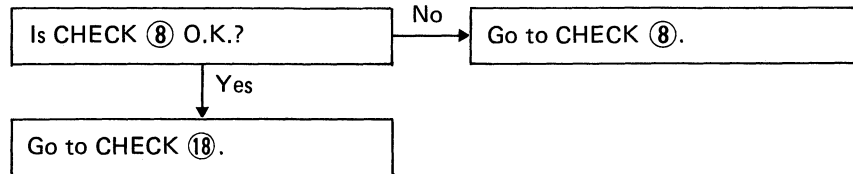

Electrical System
A/T ELECTRICAL PARTS LOCATION

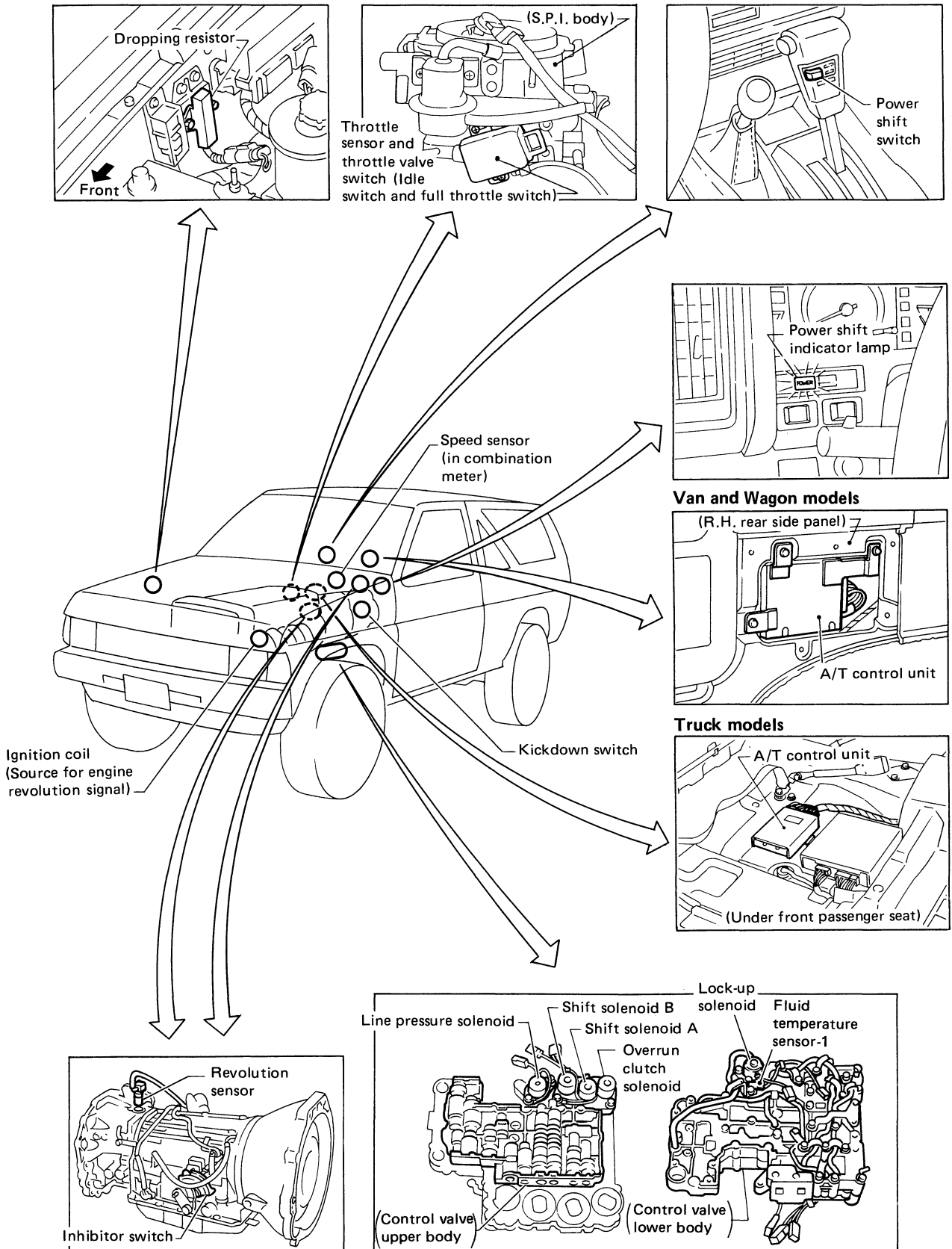

Electrical System (Cont'd)
SCHEMATIC

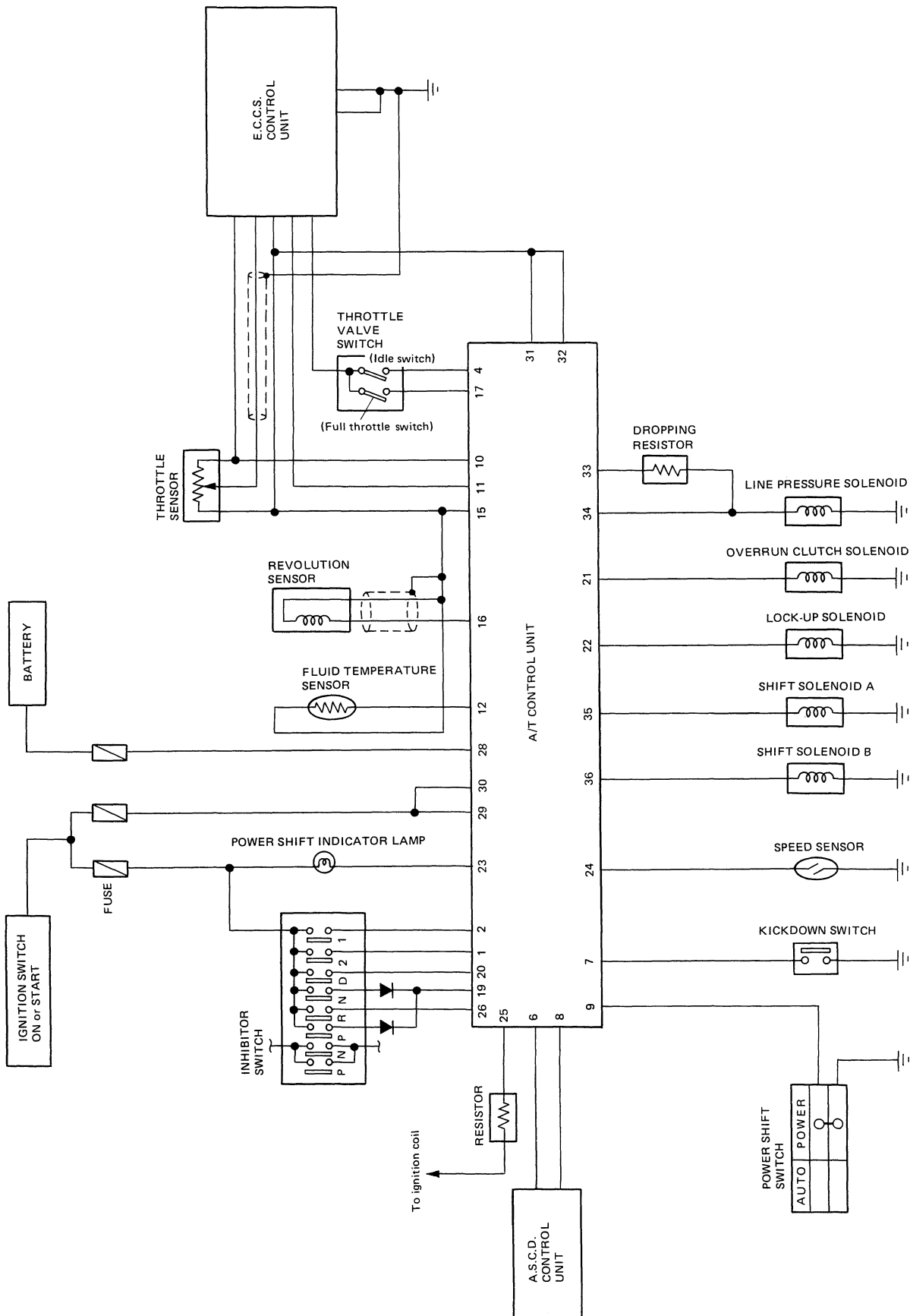

Electrical System (Cont'd)
WIRING DIAGRAM

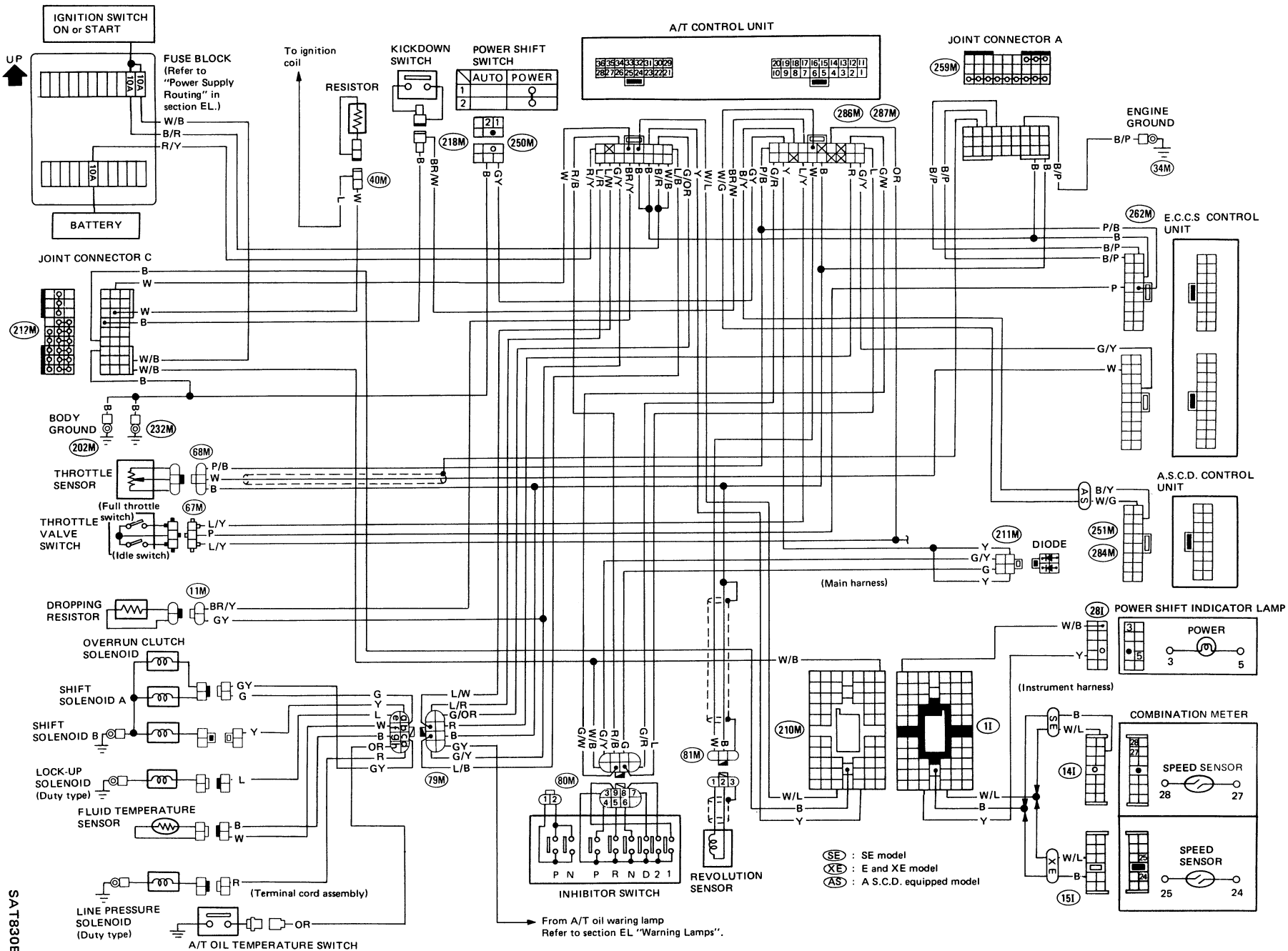

AT-179

SAT830B

Electrical System (Cont'd)

INSPECTION OF A/T CONTROL UNIT

- Measure voltage between each terminal and terminal ① or ② by following "A/T control unit inspection table".

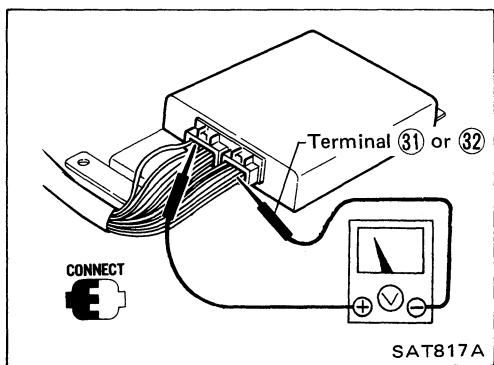

- Pin connector terminal layout.

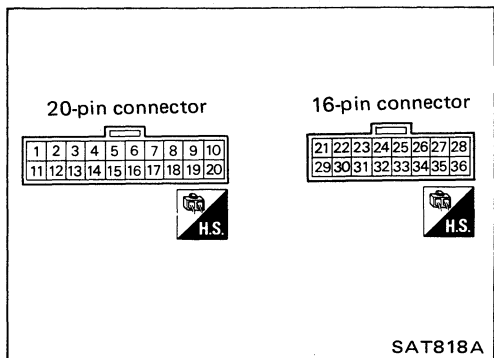







A/T CONTROL UNIT INSPECTION TABLE

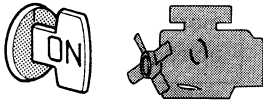

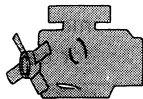
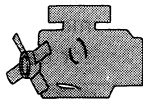

(Data are reference values.)

Terminal No.	Item	Condition	Judgement standard
1	Inhibitor "2" range switch	When setting selector lever to "2" range.	Battery voltage
		When setting selector lever to other ranges.	1V or less
2	Inhibitor "1" range switch	When setting selector lever to "1" range.	Battery voltage
		When setting selector lever to other ranges.	1V or less
3	—	—	—
4	Idle switch (in throttle valve switch)	When releasing accelerator pedal after warming up engine.	8 - 15V
		When depressing accelerator pedal after warming up engine.	1V or less
5	—	—	—
6	A.S.C.D. O.D. cut signal	When releasing "ACCEL" set switch on A.S.C.D. cruise.	5 - 8V
		When applying "ACCEL" set switch on A.S.C.D. cruise.	1V or less



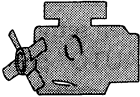
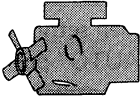

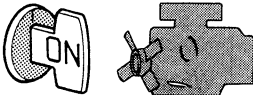
Electrical System (Cont'd)

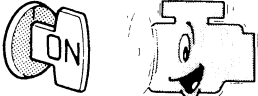
Terminal No.	Item	Condition	Judgement standard	
7	Kickdown switch		When releasing accelerator pedal after warming up engine.	3 - 8V
			When depressing accelerator pedal fully after warming up engine.	1V or less
8	A.S.C.D. cruise signal		When performing A.S.C.D. cruise. ("CRUISE" light comes on.)	Battery voltage
			When not performing A.S.C.D. cruise. ("CRUISE" light does not come on.)	1V or less
9	Power shift switch		When setting power shift switch in "AUTO" position.	3 - 8V
			When setting power shift switch in "POWER" position.	1V or less
10	Throttle sensor (Power source)		—	4.5 - 5.5V
11	Throttle sensor		When depressing accelerator pedal slowly after warming up engine.	Fully-closed throttle: 0.2 - 0.6V Fully-open throttle: 2.9 - 3.9V
			Voltage rises gradually in response to throttle opening angle.	
12	Fluid temperature sensor-1		When A.T.F. temperature is 20°C (68°F).	1.56V
			When A.T.F. temperature is 80°C (176°F).	0.45V
13	—	—	—	—
14	—	—	—	—
15	Throttle sensor (Ground)		—	—
16	Revolution sensor (Measure in AC range)		When vehicle cruises at 30 km/h (19 MPH).	1V or more Voltage rises gradually in response to vehicle speed.
			When vehicle parks.	0V

Electrical System (Cont'd)

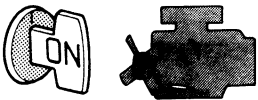
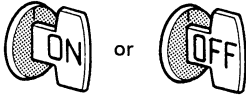
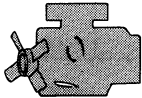
Terminal No.	Item	Condition	Judgement standard	
17	Full throttle switch		When depressing accelerator pedal more than half-way after warming up engine.	8 - 15V
			When releasing accelerator pedal after warming up engine.	1V or less
18	—	—	—	
19	Inhibitor "N" and "P" range switch		When setting selector lever to "N" or "P" range.	Battery voltage
			When setting selector lever to other ranges.	1V or less
20	Inhibitor "D" range switch		When setting selector lever to "D" range.	Battery voltage
			When setting selector lever to other ranges.	1V or less
21	Overrun clutch solenoid		When overrun clutch solenoid operates. [Ex: When driving at 50 km/h (31 MPH) in "D" range and AUTO mode with depressing accelerator pedal half-way.]	Battery voltage
			When overrun clutch solenoid does not operate. [Ex: When driving in "D" range and POWER mode with releasing accelerator pedal.]	1V or less
22	Lock-up solenoid		When A/T performs lock-up.	8 - 15V
			When A/T does not perform lock-up.	1V or less
23	Power shift indicator lamp		When setting power shift switch to "AUTO" position.	Battery voltage
			When setting power shift switch to "POWER" position.	1V or less
24	Speed sensor		When moving vehicle at 2 to 3 km/h (1 to 2 MPH) for 1 m (3 ft) or more.	Vary from 0 to 5V
25	Engine revolution signal		When engine runs at idle speed.	9.5 - 12V
			When engine runs at 2,500 rpm.	Approximately 10V

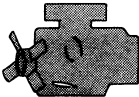
Electrical System (Cont'd)

Terminal No.	Item	Condition	Judgement standard	
26	Inhibitor "R" range switch		When setting selector lever to "R" range.	Battery voltage
			When setting selector lever to other ranges.	1V or less
27	—	—	—	
28	Power source (Back-up)		When turning ignition switch to "OFF".	Battery voltage
			When turning ignition switch to "ON".	Battery voltage
29 30	Power source		When turning ignition switch to "ON".	Battery voltage
			When turning ignition switch to "OFF".	1V or less
31 32	Ground	—	—	
33	Line pressure solenoid (with dropping resistor)		When releasing accelerator pedal after warming up engine.	5 - 14V
			When depressing accelerator pedal fully after warming up engine.	0.5V or less
34	Line pressure solenoid		When releasing accelerator pedal after warming up engine.	1.5 - 2.5V
			When depressing accelerator pedal fully after warming up engine.	0.5V or less
35	Shift solenoid A		When shift solenoid A operates. (When driving in "D ₁ " or "D ₄ ".)	Battery voltage
			When shift solenoid A does not operate. (When driving in "D ₂ " or "D ₃ ".)	1V or less
36	Shift solenoid B		When shift solenoid B operates. (When driving in "D ₁ " or "D ₂ ".)	Battery voltage
			When shift solenoid B does not operate. (When driving in "D ₃ " or "D ₄ ".)	1V or less

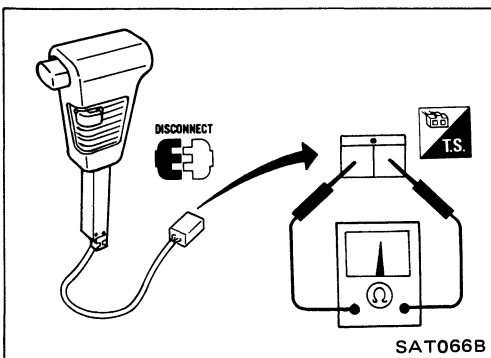

POWER SHIFT SWITCH

- Check continuity between two terminals.

Switch position	Continuity
AUTO	No
POWER	Yes

Electrical System (Cont'd)

INHIBITOR SWITCH

1. Check continuity between terminals ① and ② and between terminals ③ and ④, ⑤, ⑥, ⑦, ⑧, ⑨ while moving selector lever through each range.

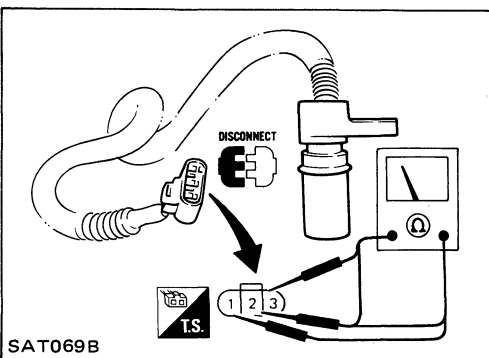
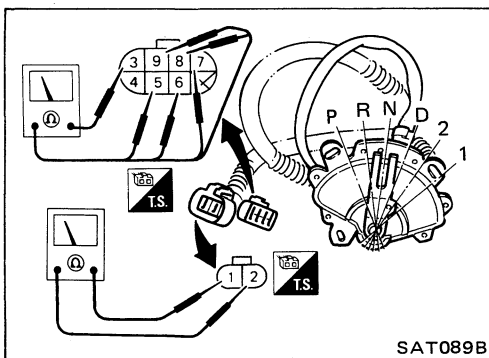
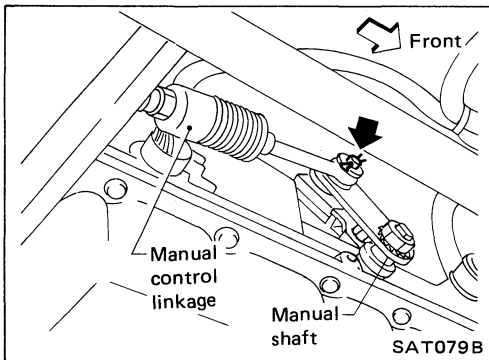
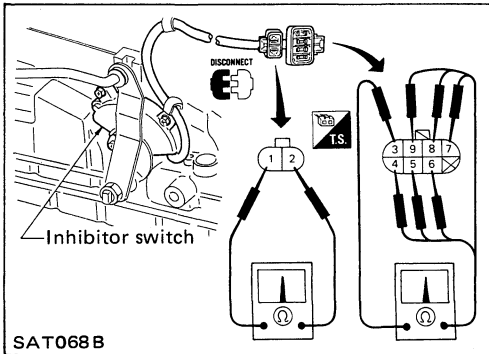
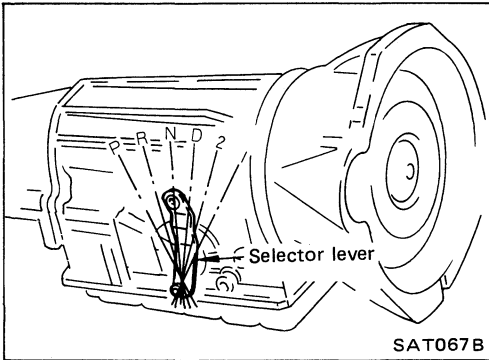

Terminal No.	①	②	③	④	⑤	⑥	⑦	⑧	⑨
Lever position									
P	○—○		○—○						
R			○—○	○—○					
N	○—○		○—○	○—○	○—○				
D			○—○	○—○	○—○	○—○			
2			○—○	○—○	○—○	○—○	○—○		
1			○—○	○—○	○—○	○—○	○—○	○—○	

2. If N.G., check again with manual control linkage disconnected from manual shaft of A/T assembly. — Refer to step 1.
3. If O.K. on step 2, adjust manual control linkage. — Refer to "ON-VEHICLE SERVICE".
4. If N.G. on step 2, remove inhibitor switch from A/T and check continuity of inhibitor switch terminal. — Refer to step 1.
5. If O.K. on step 4, adjust inhibitor switch. — Refer to "ON-VEHICLE SERVICE".
6. If N.G. on step 4, replace inhibitor switch.

REVOLUTION SENSOR

- For removal and installation, refer to "ON-VEHICLE SERVICE".
- Check resistance between terminals ①, ② and ③.

Terminal No.		Resistance
①	②	500 - 650Ω
②	③	No continuity
①	③	No continuity

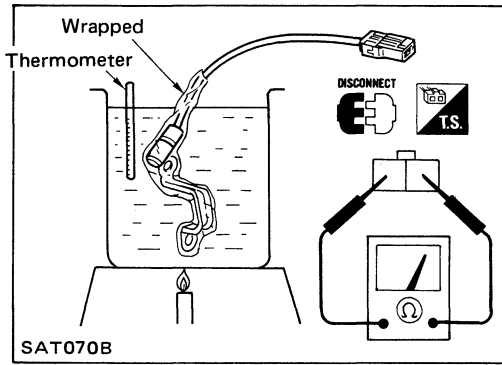

Electrical System (Cont'd)
FLUID TEMPERATURE SENSOR-1

- For removal and installation, refer to "ON-VEHICLE SERVICE".
- Check resistance between two terminals while changing temperature as shown at left.

Temperature °C (°F)	Resistance
20 (68)	Approximately 2.5 kΩ
80 (176)	Approximately 0.3 kΩ

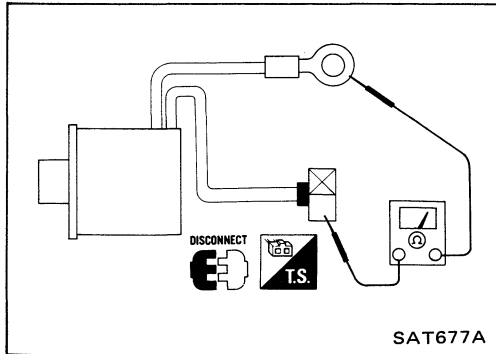

LOCK-UP SOLENOID AND LINE PRESSURE SOLENOID

- For removal and installation, refer to "ON-VEHICLE SERVICE".
- Check resistance between two terminals.

Resistance:

Lock-up solenoid: 10 - 16Ω

Line pressure solenoid: 2.5 - 5Ω

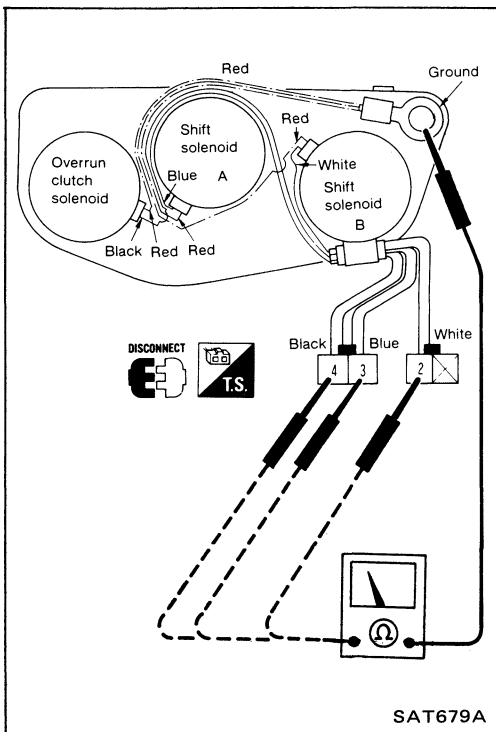

3-UNIT SOLENOID ASSEMBLY

(Shift solenoid A, B and overrun clutch solenoid)

- For removal and installation, refer to "ON-VEHICLE SERVICE".
- Check resistance between terminals of each solenoid.

Solenoid	Terminal No.	Resistance
Shift solenoid A	③	20 - 30Ω
Shift solenoid B	②	
Overrun clutch solenoid	④	

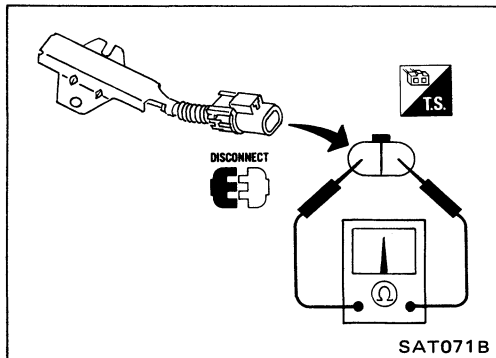

DROPPING RESISTOR

- Check resistance between two terminals.

Resistance: 11.2 - 12.8Ω

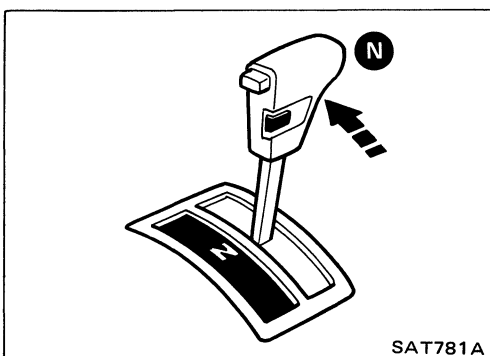
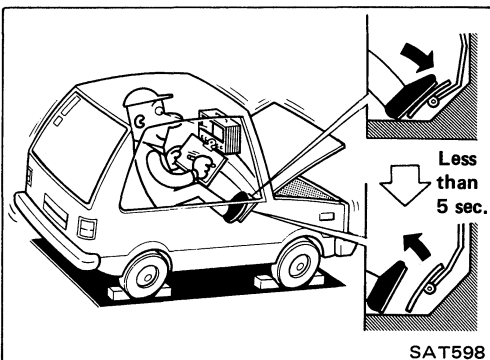
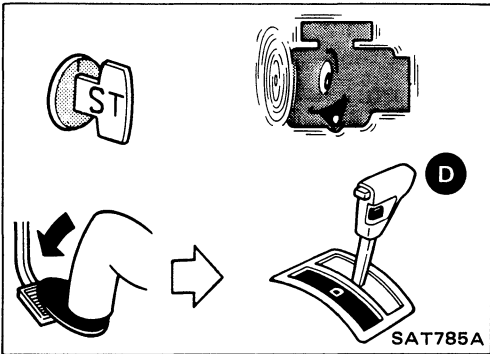
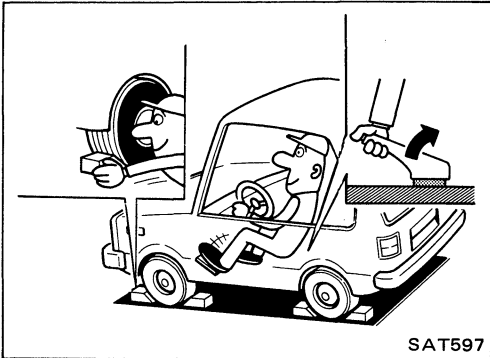
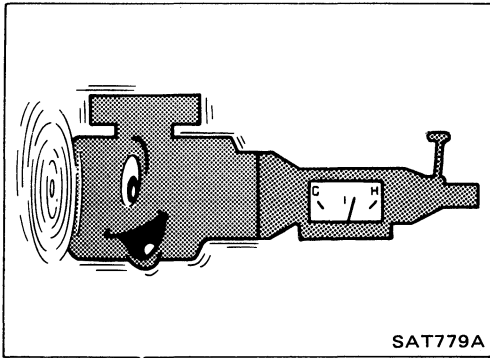

Stall Testing

STALL TEST PROCEDURE

1. Check A/T and engine fluid levels. If necessary, add.
2. Warm up engine until engine oil and A.T.F. reach operating temperature after vehicle has been driven approx. 10 minutes.

A.T.F. operating temperature:

50 - 80°C (122 - 176°F)

3. Set parking brake and block wheels.
4. Install a tachometer where it can be seen by driver during test.
 - It is good practice to put a mark on point of specified engine rpm on indicator.

5. Start engine, apply foot brake, and place selector lever in "D" range.

6. Accelerate to wide-open throttle gradually while applying foot brake.

7. Quickly note the engine stall revolution and immediately release throttle.

- During test, never hold throttle wide-open for more than 5 seconds.

Stall revolution:

2,240 - 2,440 rpm

8. Shift selector lever to "N".

9. Cool off A.T.F.

- Run engine at idle for at least one minute.

10. Perform stall tests in the same manner as in steps 5 through 9 with selector lever in "2", "1" and "R", respectively.

Stall Testing (Cont'd)

JUDGEMENT OF STALL TEST

Selector lever position	Judgement		
D	L	O	H
2	L	O	H
1	L	O	O
R	L	H	H

O : Stall revolution is normal.
 H : Stall revolution is higher than specified.
 L : Stall revolution is lower than specified.

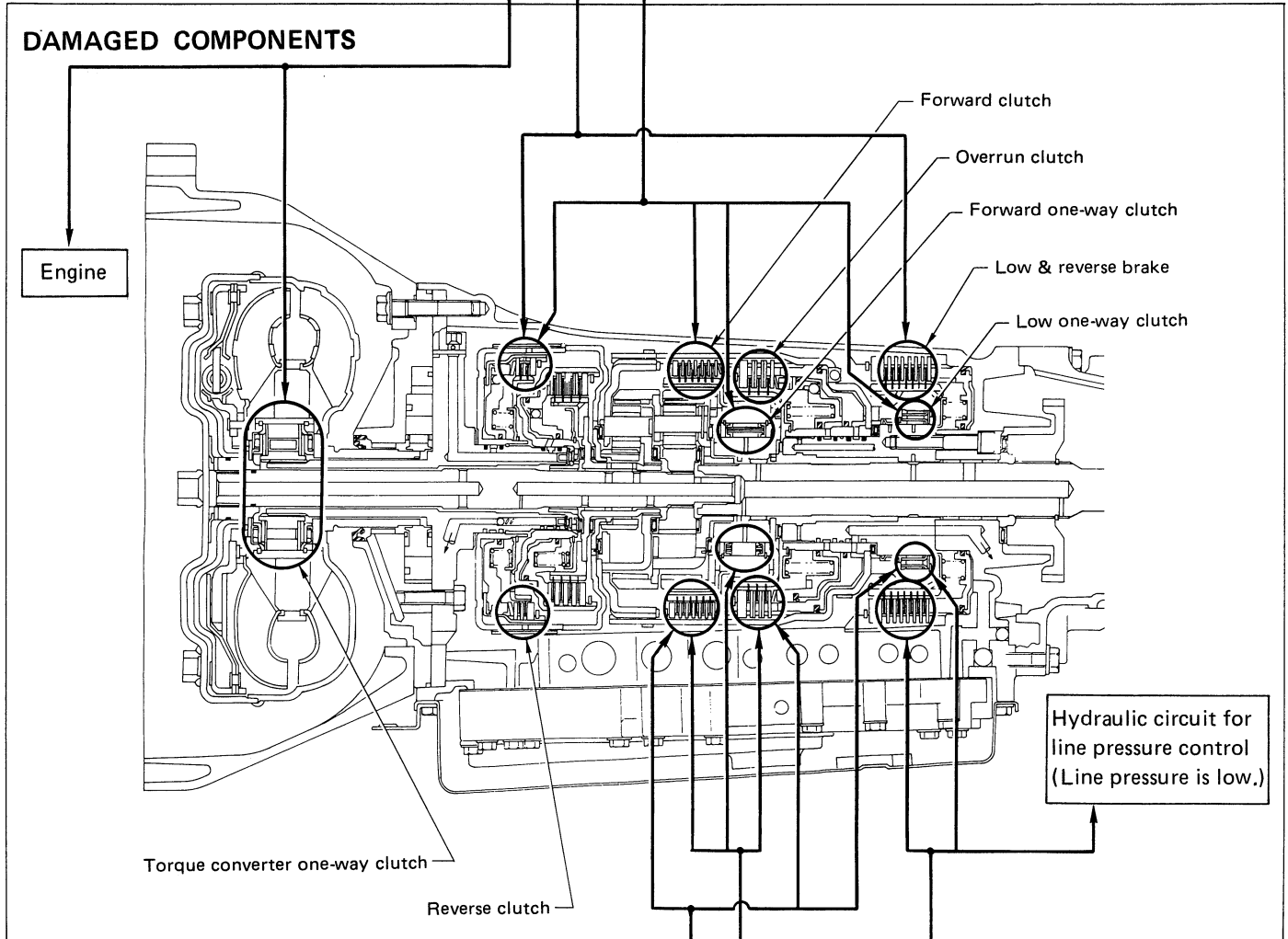

Clutches and brakes except high clutch and brake band are O.K. (Condition of high clutch and brake band cannot be confirmed by stall test.)

D	H	H	H	O
2	H	H	H	O
1	O	H	H	O
R	O	O	H	O
Selector lever position	Judgement			

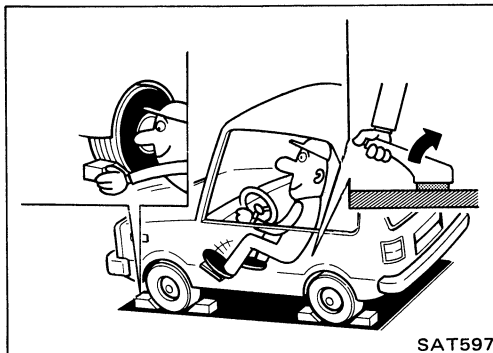
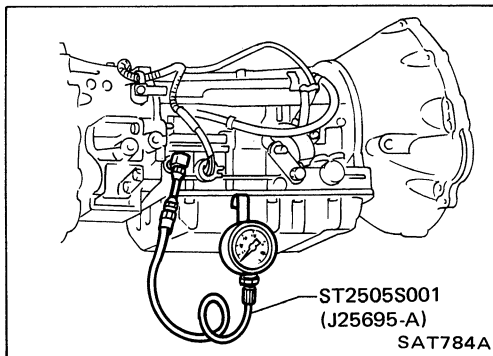
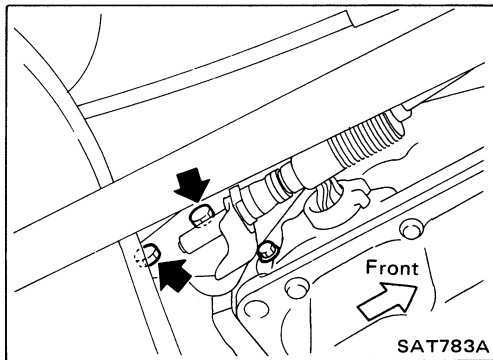
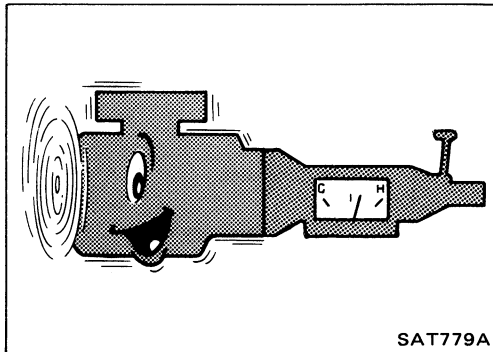
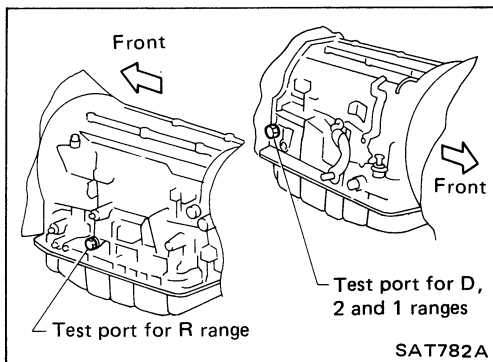

Pressure Testing

- Location of line pressure test port
- Line pressure plugs are hexagon headed bolts.
- Always replace line pressure plugs as they are self-sealing bolts.

LINE PRESSURE TEST PROCEDURE

1. Check A/T and engine fluid levels. If necessary, add.
2. Warm up engine until engine oil and A.T.F. reach operating temperature after vehicle has been driven approx. 10 minutes.

A.T.F. operating temperature:
50 - 80° C (122 - 176° F)

3. Install pressure gauge to line pressure port.
 - a. Remove control cable bracket when measuring line pressures in "D", "2" and "1" ranges.

- b. Remove line pressure plug and install Tool.

4. Set parking brake and block wheels.
 - Continue to depress brake pedal fully while line pressure test at stall speed is performed.

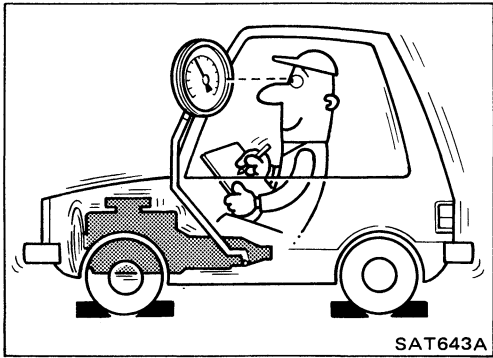

Pressure Testing (Cont'd)

5. Start engine and measure line pressure at idle and stall speed.
 - When measuring line pressure at stall speed, follow the stall test procedure.

Line pressure

Model	Engine speed rpm	Line pressure kPa (kg/cm ² , psi)	
		D, 2, and 1 ranges	R range
VG30i 4WD	Idle	432 - 471 (4.4 - 4.8, 63 - 68)	667 - 706 (6.8 - 7.2, 97 - 102)
	Stall	883 - 961 (9.0 - 9.8, 128 - 139)	1,393 - 1,471 (14.2 - 15.0, 202 - 213)

JUDGEMENT OF LINE PRESSURE TEST

Judgement		Suspected parts
At idle	Line pressure is low in all ranges.	<ul style="list-style-type: none"> • Oil pump wear • Control piston damage • Pressure regulator valve or plug sticking • Spring for pressure regulator valve damaged • Fluid pressure leakage between oil strainer and pressure regulator valve
	Line pressure is low in particular range.	<ul style="list-style-type: none"> • Fluid pressure leakage between manual valve and particular clutch. • For example; If line pressure is low in "R" and "1" ranges but is normal in "D" and "2" range, fluid leakage exists at or around low & reverse brake circuit.
	Line pressure is high.	<ul style="list-style-type: none"> • Mal-adjustment of throttle sensor • Fluid temperature sensor damaged • Line pressure solenoid sticking • Short circuit of line pressure solenoid circuit • Pressure modifier valve sticking • Pressure regulator valve or plug sticking
At stall speed	Line pressure is low.	<ul style="list-style-type: none"> • Mal-adjustment of throttle sensor • Control piston damaged • Line pressure solenoid sticking • Short-circuit of line pressure solenoid circuit • Pressure regulator valve or plug sticking • Pressure modifier valve sticking • Pilot valve sticking

Trouble-shooting Chart

Numbers are arranged in order of probability. Perform inspections starting with number one and working up. Circled numbers indicate that the transmission must be removed from the vehicle.

	ON vehicle													OFF vehicle																		
	Fluid level	Control linkage	Inhibitor switch	Throttle sensor (Adjustment)	Revolution sensor and speed sensor	Engine revolution signal	Engine idling rpm	Line pressure	Control valve assembly	Shift solenoid A	Shift solenoid B	Line pressure solenoid	Lock-up solenoid	Overrun clutch solenoid	Fluid temperature sensor	Accumulator N-D	Accumulator 1-2	Accumulator 2-3	Accumulator 3-4 (N-R)	Ignition switch and starter	Torque converter	Oil pump	Reverse clutch	High clutch	Forward clutch	Forward one-way clutch	Overrun clutch	Low one-way clutch	Low & reverse brake	Brake band	Parking components	
Engine does not start in "N", "P" ranges.	. 2	3	1
Engine starts in range other than "N" and "P".	. 1	2
Transmission noise in "P" and "N" ranges.	1	.	3	4	5	.	2	7	6	
Vehicle moves when changing into "P" range or parking gear does not disengage when shifted out of "P" range.	. 1	2	.	
Vehicle runs in "N" range.	. 1	4	.	.	.	3	.	2	.	5	
Vehicle will not run in "R" range (but runs in "D", "2" and "1" ranges). Clutch slips. Very poor acceleration.	. 1	2	4	.	.	3	5	6	7	.	8	.	9	.	.	
Vehicle braked when shifting into "R" range.	1	2	3	5	.	.	4	6	8	.	9	.	.	7	.	.	
Sharp shock in shifting from "N" to "D" range.	.	.	2	.	5	1	3	7	.	.	6	.	.	4	8	9	
Vehicle will not run in "D" and "1" ranges (but runs in "1" and "R" range).	. 1	2	
Vehicle will not run in "D", "1", "2" ranges (but runs in "R" range). Clutch slips. Very poor acceleration.	1	2	4	.	.	3	.	.	.	5	6	7	8	9	.	10	.	.	.	
Clutches or brakes slip somewhat in starting.	1	2	.	3	.	.	4	6	.	.	5	.	.	.	7	.	8	.	.	13	12	10	.	9	.	.	.	11	.	.	.	
Excessive creep.	1	
No creep at all.	1	2	3	6	5	.	.	4	
Failure to change gear from "D ₁ " to "D ₂ ".	. 2	1	.	5	.	.	4	3	6	.	
Failure to change gear from "D ₂ " to "D ₃ ".	. 2	1	.	5	.	.	4	3	6	7	.	
Failure to change gear from "D ₃ " to "D ₄ ".	. 2	1	.	4	.	.	3	5	6	.	
Too high a gear change point from "D ₁ " to "D ₂ ", from "D ₂ " to "D ₃ ", from "D ₃ " to "D ₄ ".	.	.	1	2	.	.	.	3	4	
Gear change directly from "D ₁ " to "D ₃ " occurs.	1	2	3	.	
Engine stops when shifting lever into "R", "D", "2" and "1".	1	.	3	.	.	.	2	4	
Too sharp a shock in change from "D ₁ " to "D ₂ ".	.	.	1	.	.	2	4	5	.	3	6	.	
Too sharp a shock in change from "D ₂ " to "D ₃ ".	.	.	1	.	.	2	4	3	6	.	

Trouble-shooting Chart (Cont'd)

Numbers are arranged in order of probability. Perform inspections starting with number one and working up. Circled numbers indicate that the transmission must be removed from the vehicle.

	ON vehicle													OFF vehicle																		
	Fluid level	Control linkage	Inhibitor switch	Throttle sensor (Adjustment)	Revolution sensor and speed sensor	Engine revolution signal	Engine idling rpm	Line pressure	Control valve assembly	Shift solenoid A	Shift solenoid B	Line pressure solenoid	Lock-up solenoid	Overrun clutch solenoid	Fluid temperature sensor	Accumulator N-D	Accumulator 1-2	Accumulator 2-3	Accumulator 3-4 (N-R)	Ignition switch and starter	Torque converter	Oil pump	Reverse clutch	High clutch	Forward clutch	Forward one-way clutch	Overrun clutch	Low one-way clutch	Low & reverse brake	Brake band	Parking components	
Too sharp a shock in change from "D ₃ " to "D ₄ ".	.	.	.	1	.	.	.	2	4	3	6	.	.	5	.	
Almost no shock or clutches slipping in change from "D ₁ " to "D ₂ ".	1	.	.	2	.	.	.	3	5	4	6	.
Almost no shock or slipping in change from "D ₂ " to "D ₃ ".	1	.	.	2	.	.	.	3	5	4	6	7	.
Almost no shock or slipping in change from "D ₃ " to "D ₄ ".	1	.	.	2	.	.	.	3	5	4	6	7	.
Vehicle braked by gear change from "D ₁ " to "D ₂ ".	1	2	4	.	.	.	5	3	.	.	
Vehicle braked by gear change from "D ₂ " to "D ₃ ".	1	2	.
Vehicle braked by gear change from "D ₃ " to "D ₄ ".	1	4	.	.	3	2
Maximum speed not attained. Acceleration poor.	1	.	2	5	3	4	11	10	6	7	9	8	.	
Failure to change gear from "D ₄ " to "D ₃ ".	1	.	.	2	6	4	.	5	.	3	8	.	7	.	.	
Failure to change gear from "D ₃ " to "D ₂ " or from "D ₄ " to "D ₂ ".	1	.	.	2	5	3	4	6	7	.	
Failure to change gear from "D ₂ " to "D ₁ " or from "D ₃ " to "D ₁ ".	1	.	.	2	5	3	4	7	.	.	6	.	8	.		
Gear change shock felt during deceleration by releasing accelerator pedal.	.	.	.	1	.	.	.	2	4	.	.	.	3	
Too high a change point from "D ₄ " to "D ₃ ", from "D ₃ " to "D ₂ ", from "D ₂ " to "D ₁ ".	.	.	.	1	2	
Kickdown does not operate when depressing pedal in "D ₄ " within kickdown vehicle speed.	.	.	.	1	2	3	4		
Kickdown operates or engine overruns when depressing pedal in "D ₄ " beyond kickdown vehicle speed limit.	.	.	.	2	1	3	4		
Races extremely fast or slips in changing from "D ₄ " to "D ₃ " when depressing pedal.	1	.	.	2	.	.	.	3	5	.	4	6	7		
Races extremely fast or slips in changing from "D ₄ " to "D ₂ " when depressing pedal.	1	.	.	2	.	.	.	3	6	5	.	4	8	.	.	.	7	.		
Races extremely fast or slips in changing from "D ₃ " to "D ₂ " when depressing pedal.	1	.	.	2	.	.	.	3	5	.	4	.	.	8	.	0	9	7	6	.		
Races extremely fast or slips in changing from "D ₄ " or "D ₃ " to "D ₁ " when depressing pedal.	1	.	.	2	.	.	.	3	5	.	4	6	7	.	8	.	.	.		
Vehicle will not run in any range.	1	2	3	.	.	4	9	5	.	6	8	7	10	
Transmission noise in "D", "2", "1" and "R" ranges.	1	2		

Trouble-shooting Chart (Cont'd)

Numbers are arranged in order of probability. Perform inspections starting with number one and working up. Circled numbers indicate that the transmission must be removed from the vehicle.

	ON vehicle													OFF vehicle																	
	Fluid level	Control linkage	Inhibitor switch	Throttle sensor (Adjustment)	Revolution sensor and speed sensor	Engine revolution signal	Engine idling rpm	Line pressure	Control valve assembly	Shift solenoid A	Shift solenoid B	Line pressure solenoid	Lock-up solenoid	Overrun clutch solenoid	Fluid temperature sensor	Accumulator N-D	Accumulator 1-2	Accumulator 2-3	Accumulator 3-4 (N-R)	Ignition switch and starter	Torque converter	Oil pump	Reverse clutch	High clutch	Forward clutch	Forward one-way clutch	Overrun clutch	Low one-way clutch	Low & reverse brake	Brake band	Parking components
Failure to change from "D ₃ " to "2" when changing lever into "2" range.	.	7	1	2	6	5	4	.	3	9	.	.	8	.
Gear change from "2 ₁ " to "2 ₃ " in "2" range.	.	.	1
Engine brake does not operate in "1" range.	.	2	1	3	4	.	.	.	6	5	.	.	7	8	.	9	.	.	
Gear change from "1 ₁ " to "1 ₂ " in "1" range.	.	2	1	
Does not change from "1 ₁ " to "1 ₁ " in "1" range.	.	.	1	.	2	.	.	.	4	3	.	.	5	6	.	7	.	.	
Large shock changing from "1 ₂ " to "1 ₁ " in "1" range.	1	2	.	.	.	
Transmission overheats.	1	.	.	3	.	.	2	4	6	.	.	5	14	7	8	9	11	12	.	13	10	.	
A.T.F. shoots out during operation. White smoke emitted from exhaust pipe during operation.	1	2	3	5	6	.	7	4	.	
Offensive smell at fluid charging pipe.	1	2	3	4	5	7	.	8	.	9	6	.
Torque converter is not locked up.	.	.	3	1	2	4	.	6	8	.	.	.	7	.	5	9
Lock-up piston slip	1	.	.	2	.	.	.	3	6	.	.	5	4	7
Lock-up point is extremely high or low.	.	.	.	1	2	.	.	.	4	.	.	.	3
A/T does not shift to "D ₄ " when driving in "AUTO" mode.	.	.	2	1	3	.	.	8	6	4	.	.	.	5	7	10	.	.	9	.	
Engine is stopped at "R", "D", "2" and "1" ranges.	1	5	4	3	.	2

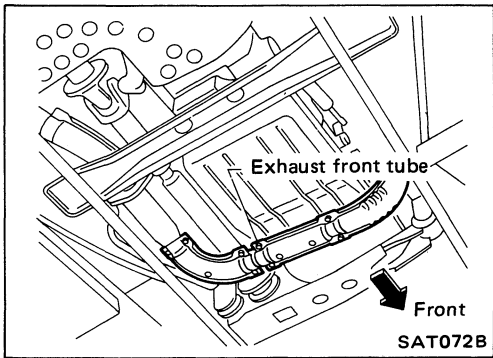

Removal

- Remove exhaust front tube.
- Remove fluid charging pipe from A/T assembly.
- Remove bolts securing torque converter to drive plate.
- **Remove those bolts by turning crankshaft.**
- Plug up opening such as oil charging pipe hole, etc.

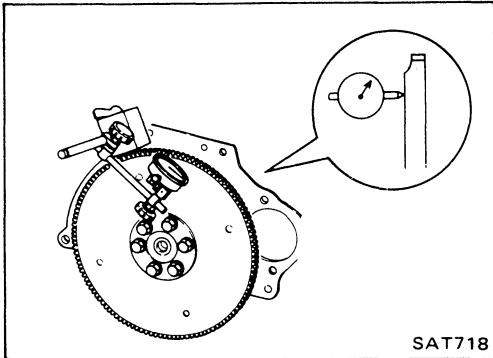

Installation

- Drive plate runout
**Maximum allowable runout:
 0.5 mm (0.020 in)**
 If this runout is out of allowance; replace drive plate with ring gear.

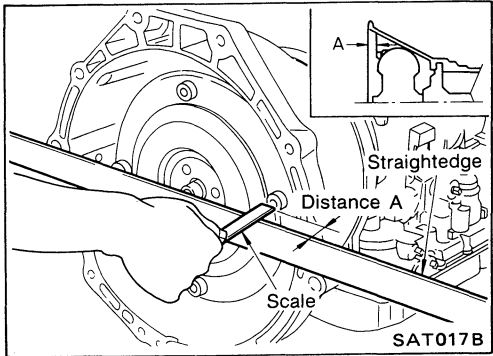





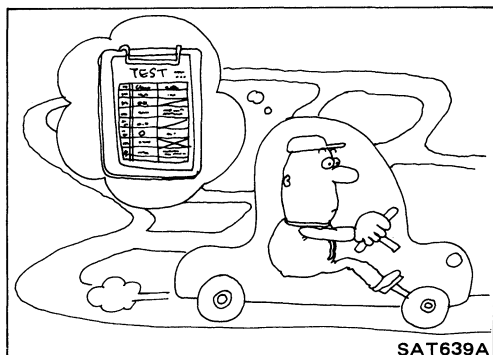

- When connecting torque converter to transmission, measure distance "A" to be certain that they are correctly assembled.
**Distance "A":
 26 mm (1.02 in) or more**
- Install converter to drive plate.
- Reinstall any part removed.
- **After converter is installed, rotate crankshaft several turns and check to be sure that transmission rotates freely without binding.**



- Check fluid level in transmission.
- Move selector lever through all positions to be sure that transmission operates correctly.
 With parking brake applied, rotate engine at idling. Move selector lever through "N" to "D", to "2", to "1" and to "R". A slight shock should be felt by hand gripping selector each time transmission is shifted.



- Perform road test. – Refer to "Road Testing".

-  : N·m (kg-m, ft-lb)
-  : Apply recommended sealant (Nissan genuine part: KP610-00250) or equivalent.
-  : Apply A.T.F.
-  : Apply petroleum jelly
-  : Select with proper thickness.
-  : Adjustment is required.

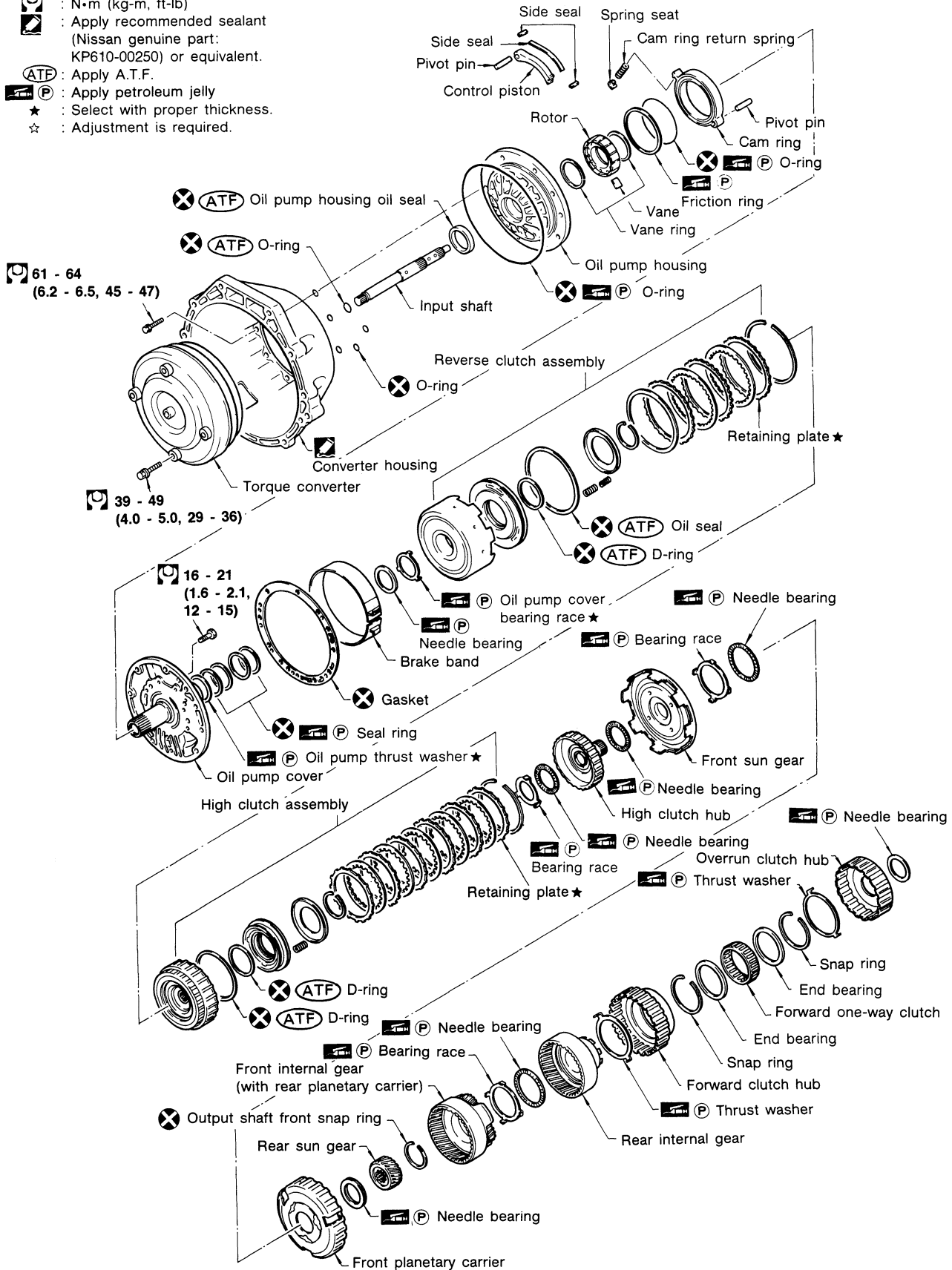

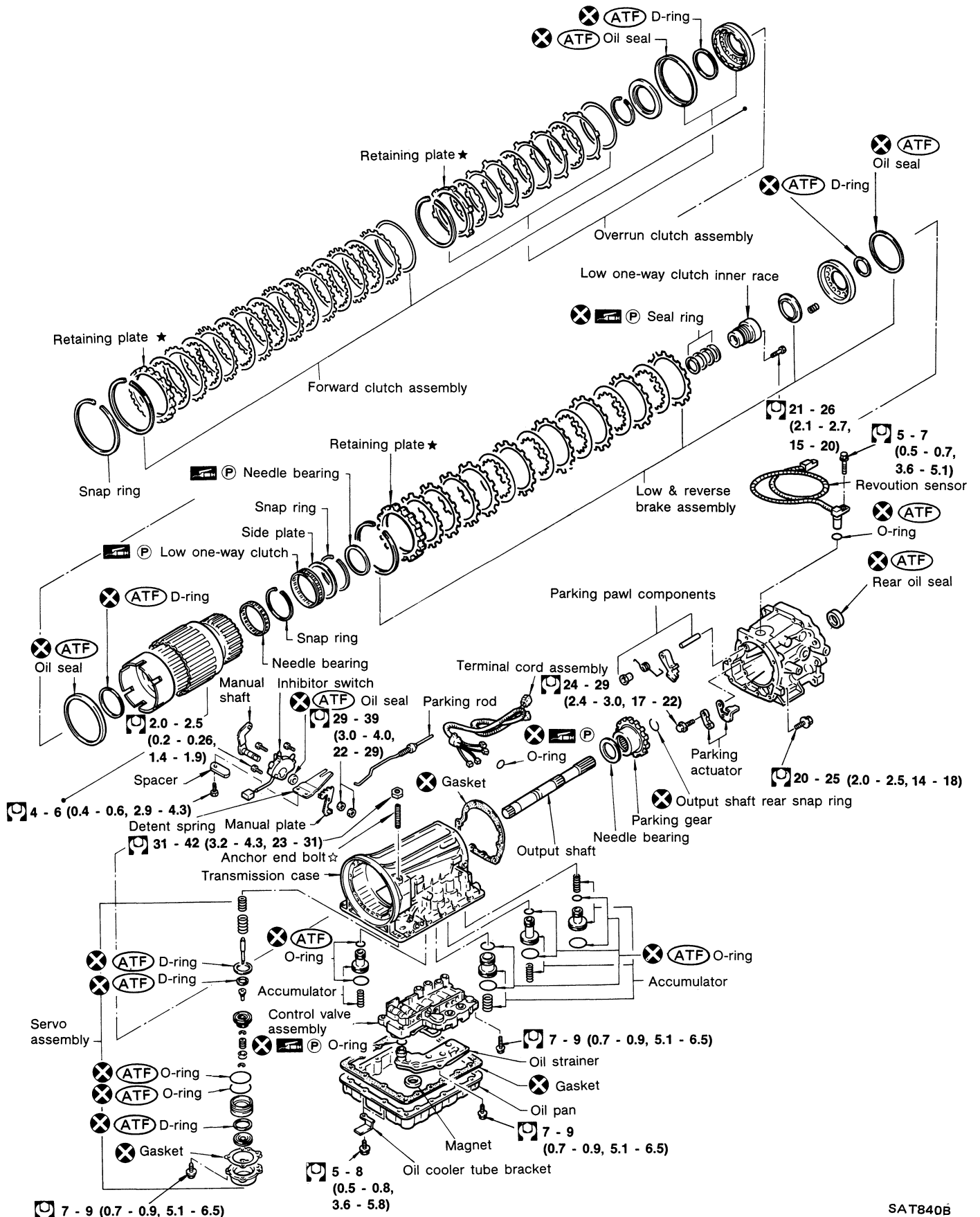

SAT840B

Oil Channel

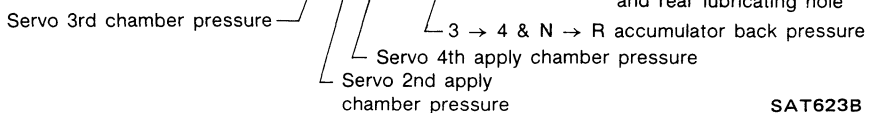
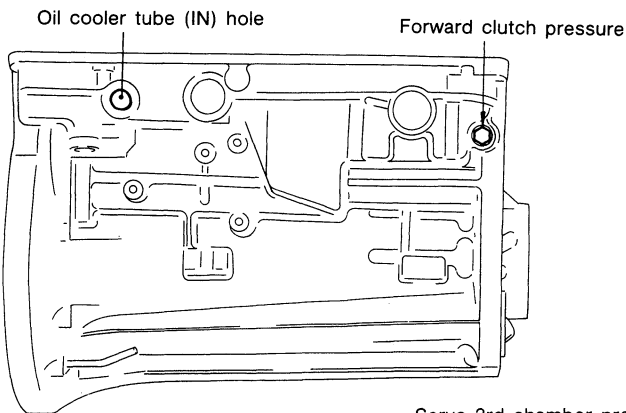
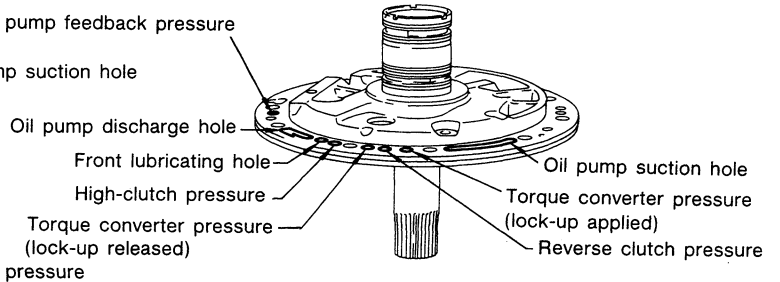
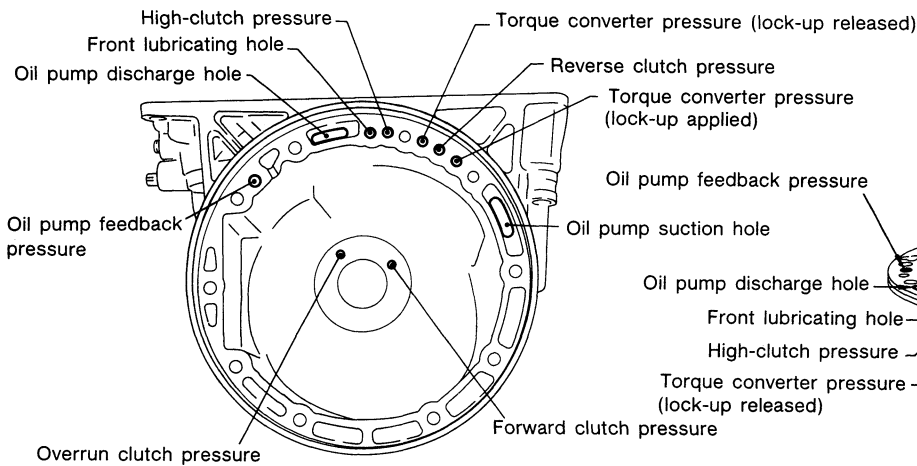
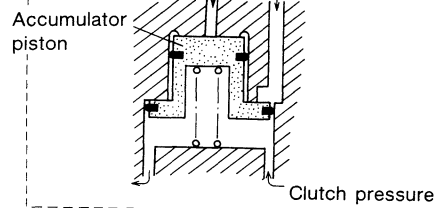
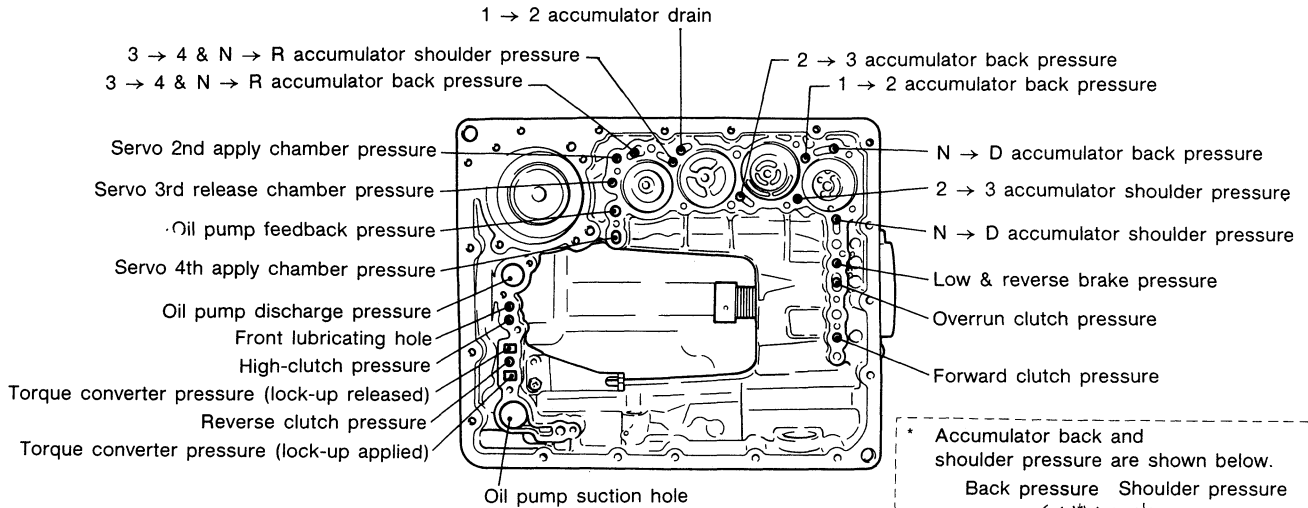

Locations of Needle Bearings, Thrust Washers and Snap Rings

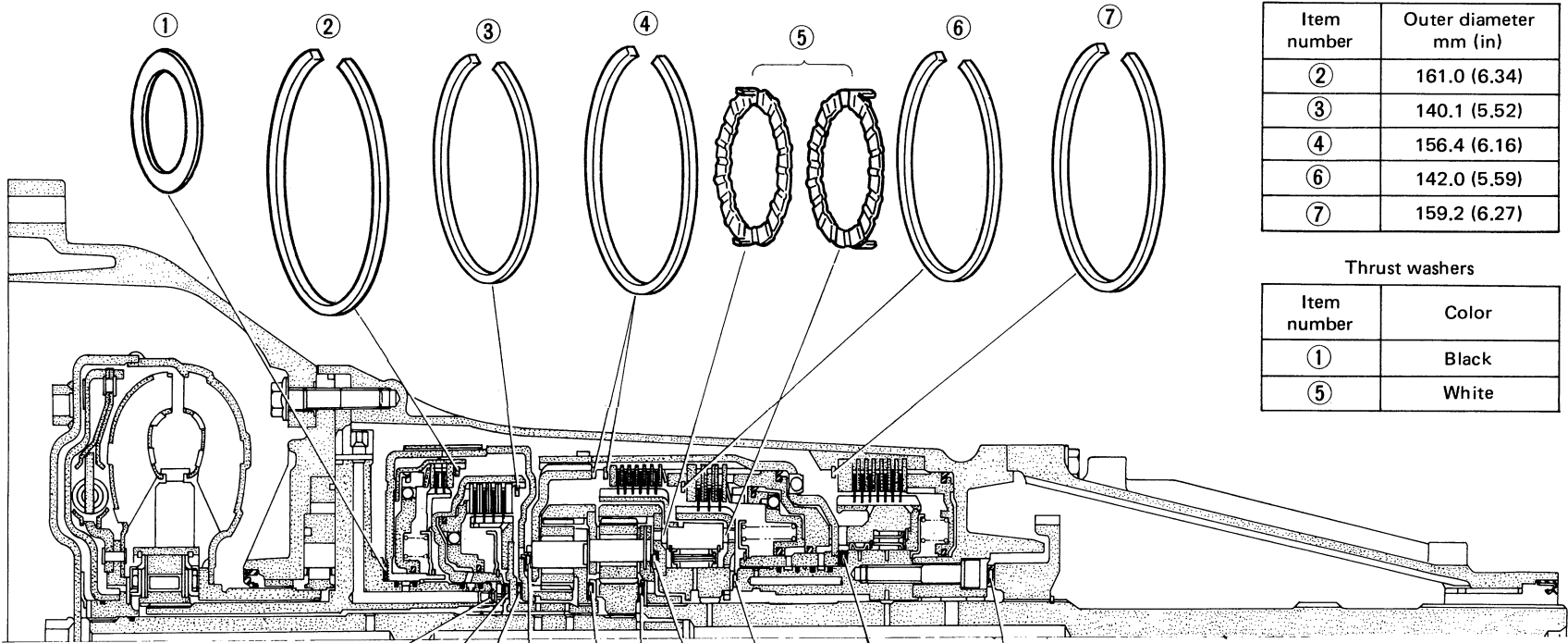

Outer diameter of snap rings

Item number	Outer diameter mm (in)
②	161.0 (6.34)
③	140.1 (5.52)
④	156.4 (6.16)
⑥	142.0 (5.59)
⑦	159.2 (6.27)

Thrust washers

Item number	Color
①	Black
⑤	White

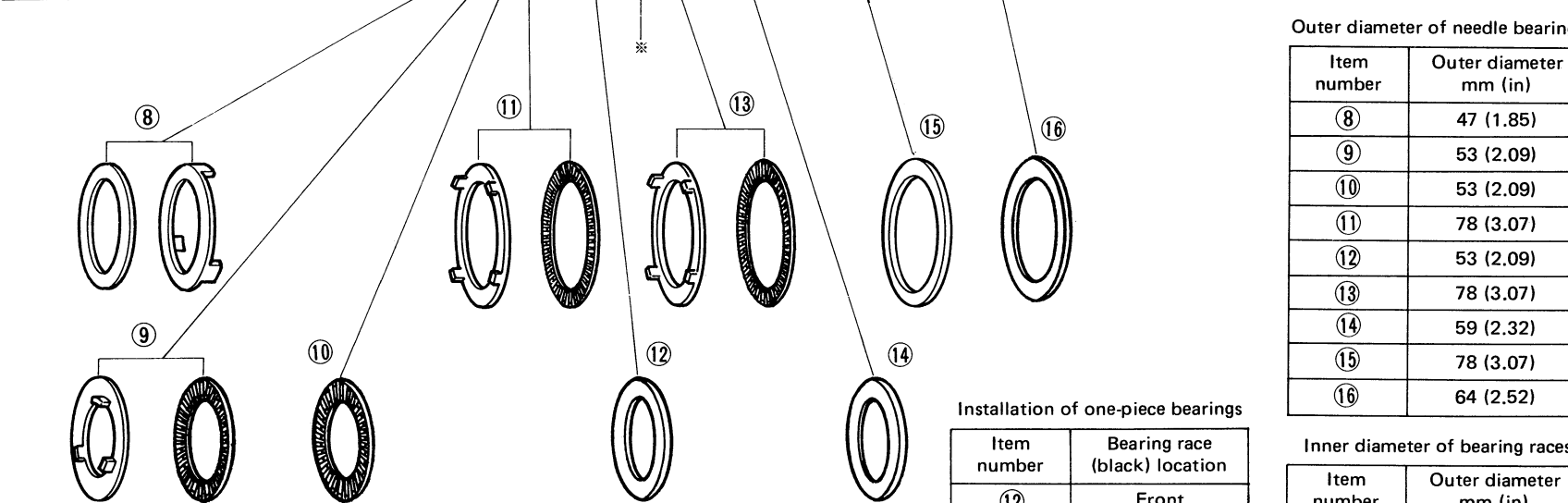

Outer diameter of needle bearings

Item number	Outer diameter mm (in)
⑧	47 (1.85)
⑨	53 (2.09)
⑩	53 (2.09)
⑪	78 (3.07)
⑫	53 (2.09)
⑬	78 (3.07)
⑭	59 (2.32)
⑮	78 (3.07)
⑯	64 (2.52)

Installation of one-piece bearings

Item number	Bearing race (black) location
⑫	Front
⑮	Rear side
⑯	Rear side

Inner diameter of bearing races

Item number	Outer diameter mm (in)
⑪	58 (2.28)
⑬	58.8 (2.315)

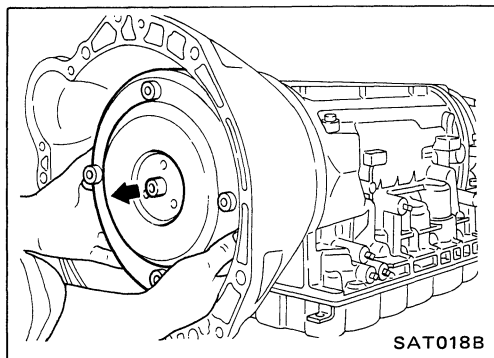

Disassembly

1. Remove torque converter by holding it firmly and turning while pulling straight out.

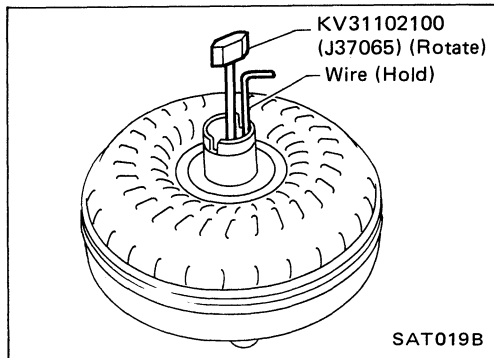

2. Check torque converter one-way clutch.
 - a. Insert Tool into spline of one-way clutch inner race.
 - b. Hook bearing support unitized with one-way clutch outer race with suitable wire.
 - c. Check that one-way clutch inner race rotates only clockwise with Tool while holding bearing support with wire.

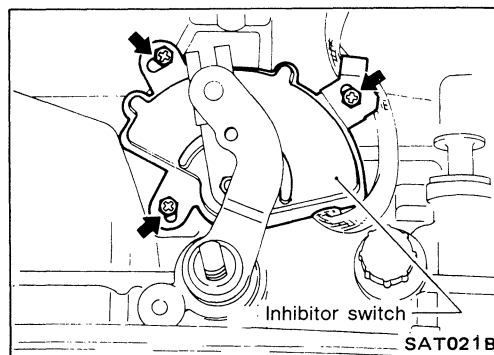

3. Remove inhibitor switch from transmission case.

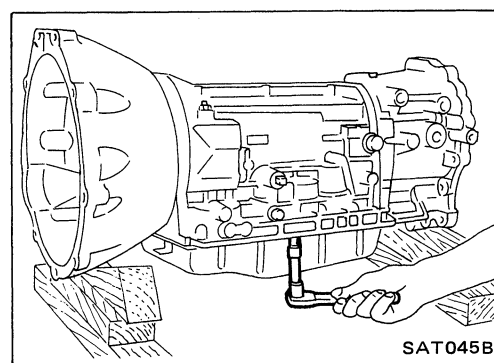

4. Remove oil pan.
 - a. Drain A.T.F. from adapter case.
 - b. Raise oil pan by placing wooden blocks under converter housing and adapter case.
 - c. Separate the oil pan and transmission case.
 - **Always place oil pan straight down so that foreign particles inside will not move.**

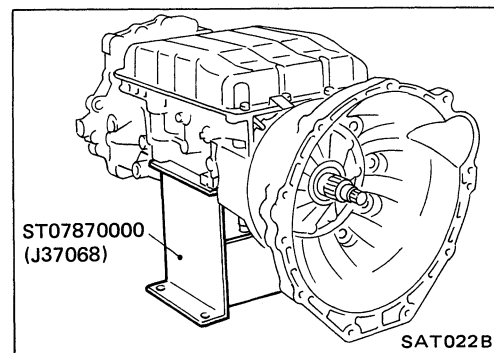

5. Place transmission into Tool with the control valve facing up.

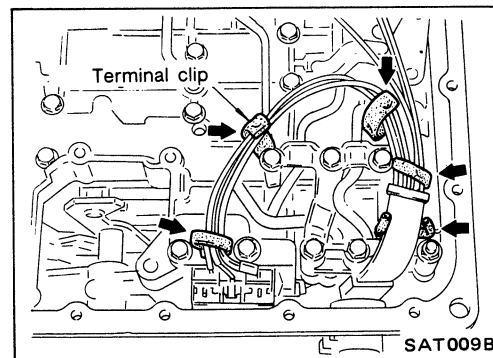
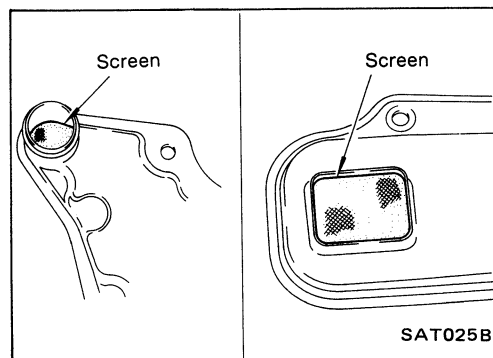
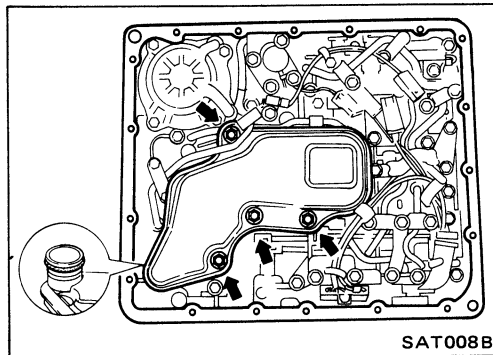
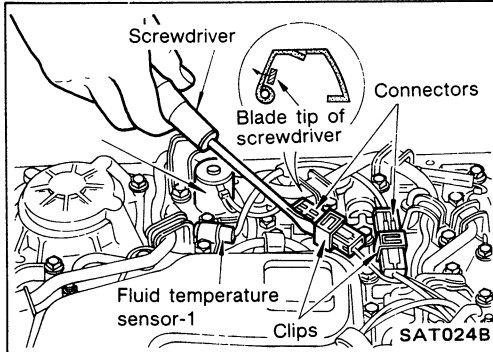
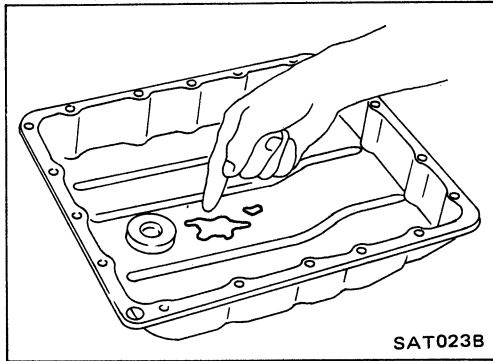
**Disassembly (Cont'd)**

6. Check oil pan and oil strainer for accumulation of foreign particles.

- If materials of clutch facing are found, clutch plates may be worn.
- If metal filings are found, clutch plates, brake bands, etc. may be worn.
- If aluminum filings are found, bushings or aluminum cast parts may be worn.

In above cases, replace torque converter and check unit for cause of particle accumulation.

7. Remove lock-up solenoid and fluid temperature sensor-1 and 2 connectors.

- **Be careful not to damage connector.**

8. Remove oil strainer.

- a. Remove oil strainer from control valve assembly. Then remove O-ring from oil strainer.

- b. Check oil strainer screen for damage.

9. Remove control valve assembly.

- a. Straighten terminal clips to free terminal cords then remove terminal clips.

Disassembly (Cont'd)

- b. Remove bolts (A) and (B), and remove control valve assembly from transmission.

Bolt	Length
(A)	37 mm (1.46 in)
(B)	50 mm (1.97 in)

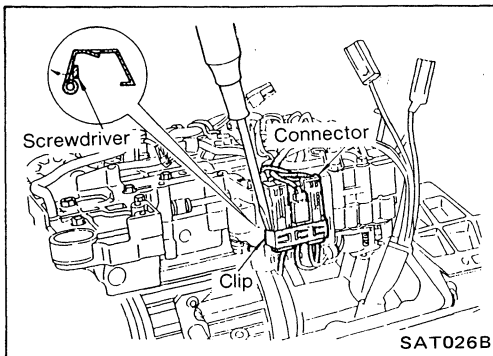
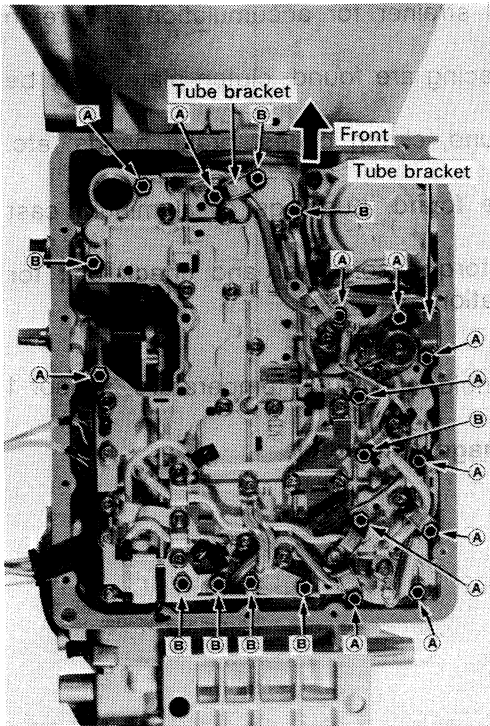

- c. Remove solenoid connector.
 ● Be careful not to damage connector.

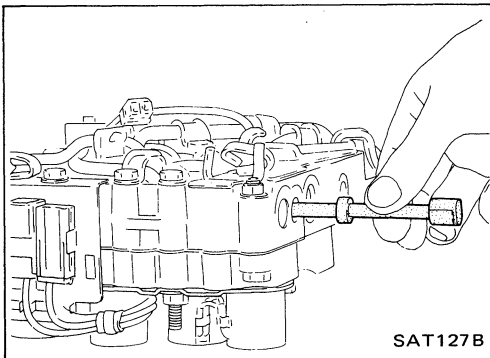

- d. Remove manual valve from control valve assembly.

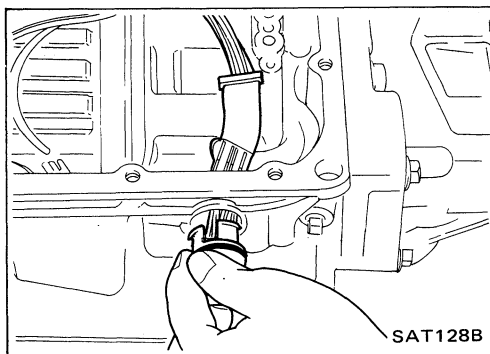

10. Remove terminal cord assembly from transmission case while pushing on stopper.
 ● Be careful not to damage cord.
 ● Do not remove terminal cord assembly unless it is damaged.

Disassembly (Cont'd)

11. Remove converter housing.
 a. Remove converter housing from transmission case.

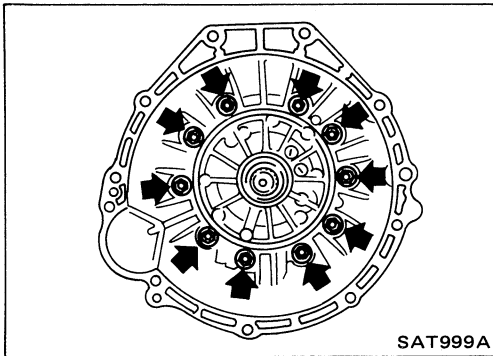

- b. Remove O-rings from converter housing.
 c. Remove traces of sealant.
 ● **Be careful not to scratch converter housing.**

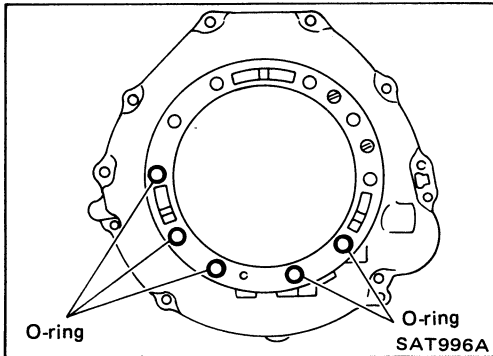

12. Remove O-ring from input shaft.

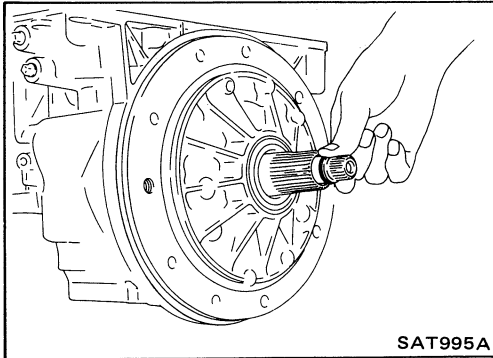

13. Remove oil pump assembly.
 a. Attach Tool to oil pump assembly and extract it evenly from transmission case.

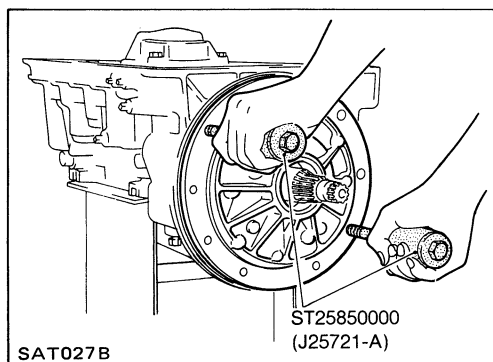

- b. Remove O-ring from oil pump assembly.
 c. Remove traces of sealant from oil pump housing.
 ● **Be careful not to scratch pump housing.**

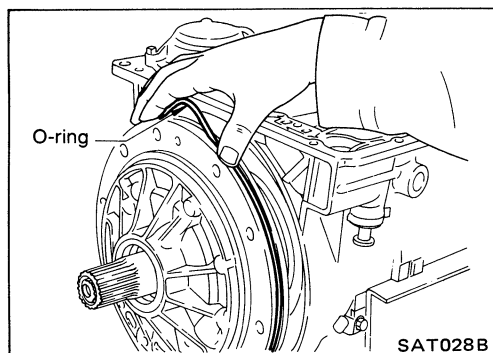

Disassembly (Cont'd)

d. Remove needle bearing and thrust washer from oil pump assembly.

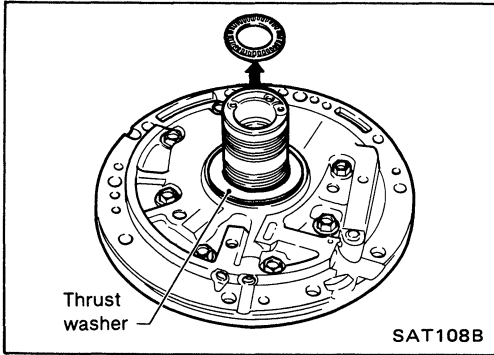

14. Remove input shaft and oil pump gasket.

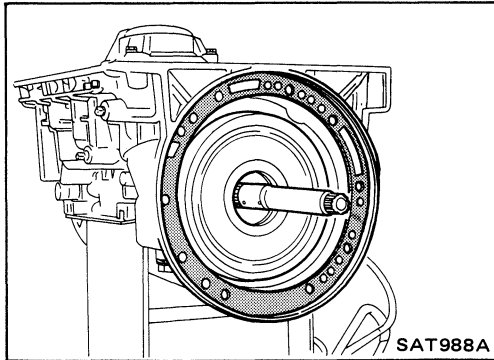

15. Remove brake band and band strut.

a. Loosen lock nut and remove band servo anchor end pin from transmission case.

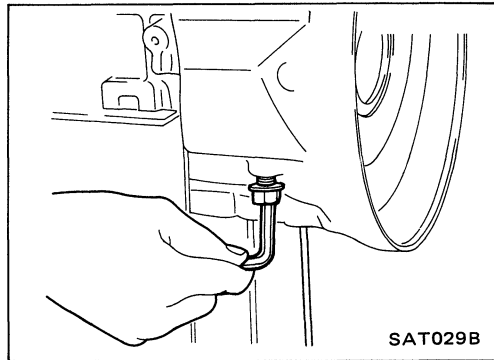

b. Remove brake band and band strut from transmission case.

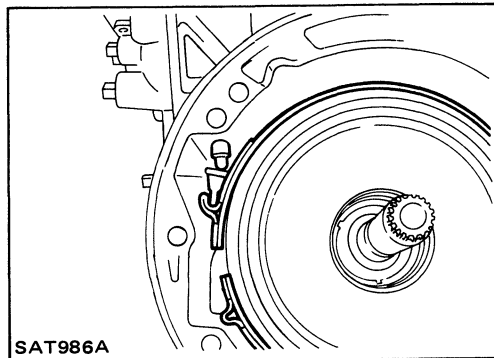

c. Hold brake band in a circular shape with clip.

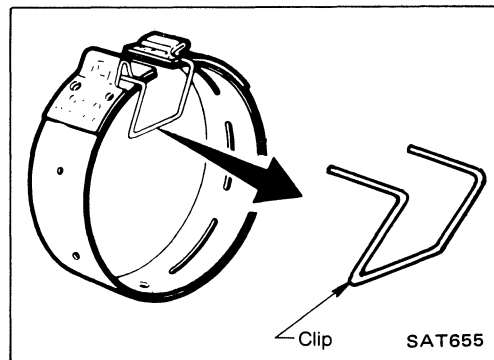

Disassembly (Cont'd)

16. Remove front side clutch and gear components.
 a. Remove clutch pack (reverse clutch, high clutch and front sun gear) from transmission case.

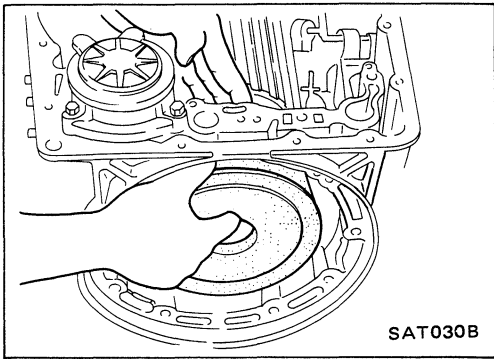

- b. Remove front bearing race from clutch pack.
 c. Remove rear bearing race from clutch pack.

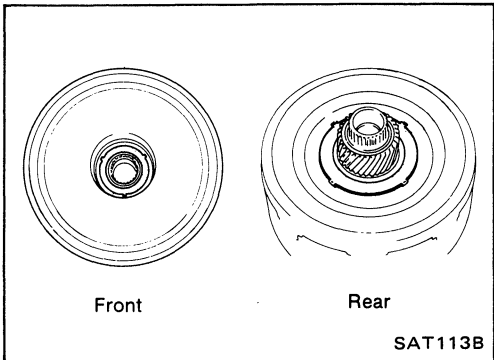

- d. Remove front planetary carrier from transmission case.

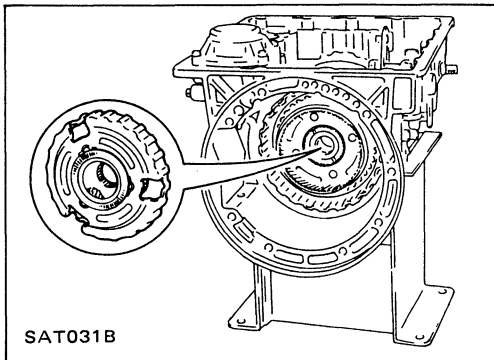

- e. Remove front needle bearing from front planetary carrier.
 f. Remove rear bearing from front planetary carrier.

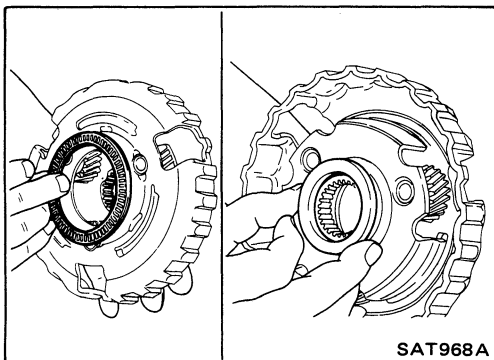

- g. Remove rear sun gear from transmission case.

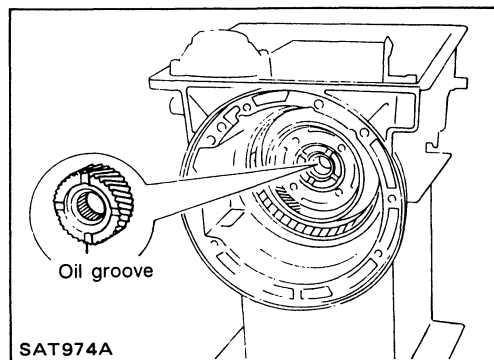

Disassembly (Cont'd)

17. Remove adapter case.

- a. Remove adapter case from transmission case.
- b. Remove adapter case gasket from transmission case.

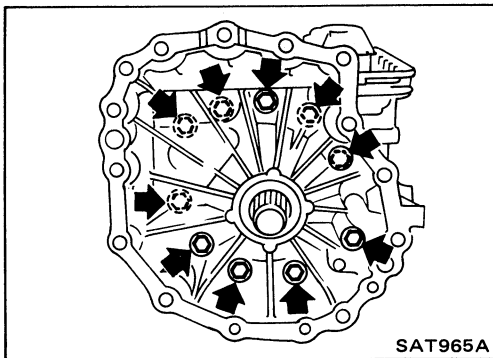

c. Remove oil seal from rear extension.

- Do not remove oil seal unless it is to be replaced.

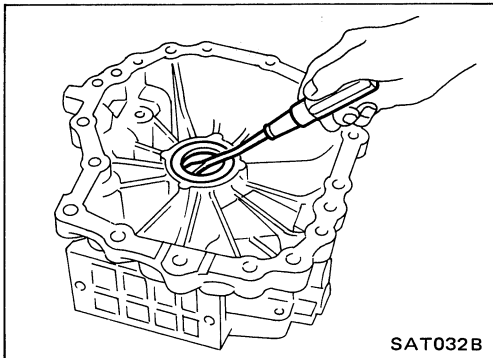

d. Remove revolution sensor from adapter case.

e. Remove O-ring from revolution sensor.

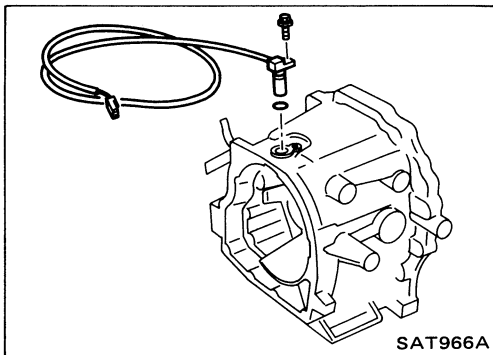

18. Remove output shaft and parking gear.

a. Remove rear snap ring from output shaft.

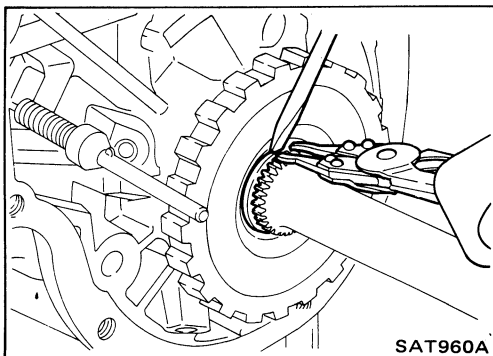

b. Slowly push output shaft all the way forward.

- Do not use excessive force.

c. Remove snap ring from output shaft.

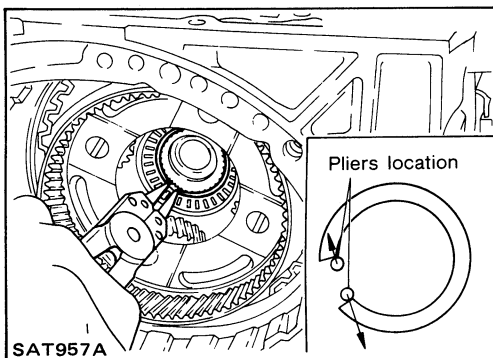

Disassembly (Cont'd)

- d. Remove output shaft and parking gear as a unit from transmission case.
- e. Remove parking gear from output shaft.

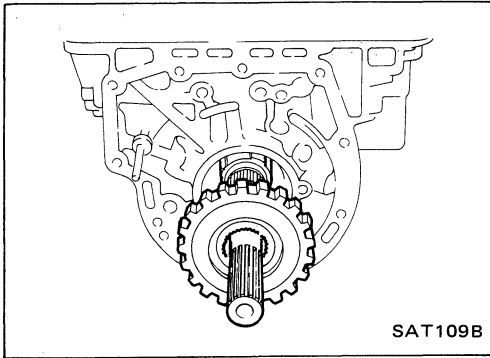

- f. Remove needle bearing from transmission case.

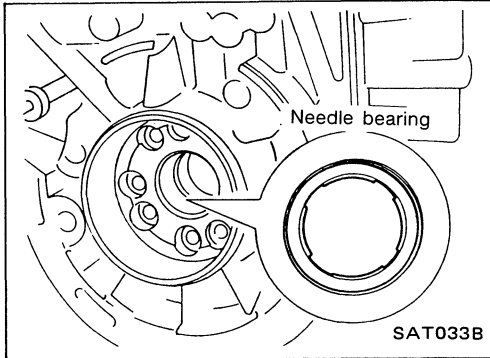

19. Remove rear side clutch and gear components.
 - a. Remove front internal gear.

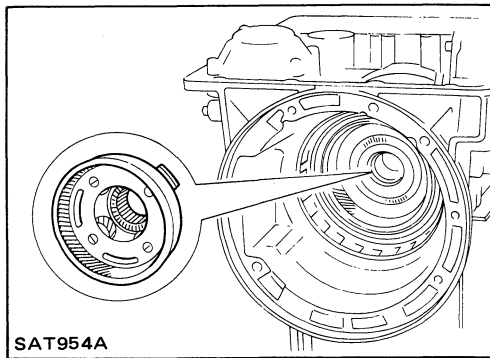

- b. Remove bearing race from front internal gear.

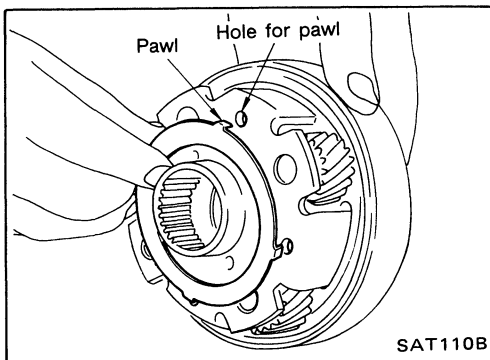

- c. Remove needle bearing from rear internal gear.

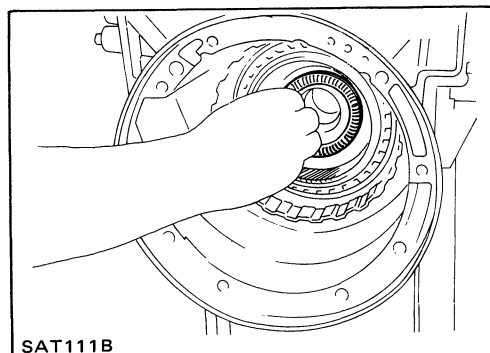

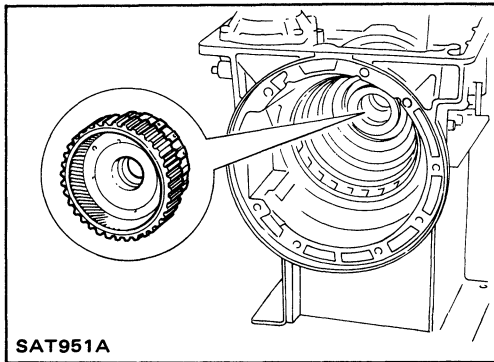
Disassembly (Cont'd)

SAT951A

- d. Remove rear internal gear, forward clutch hub and overrun clutch hub as a set from transmission case.

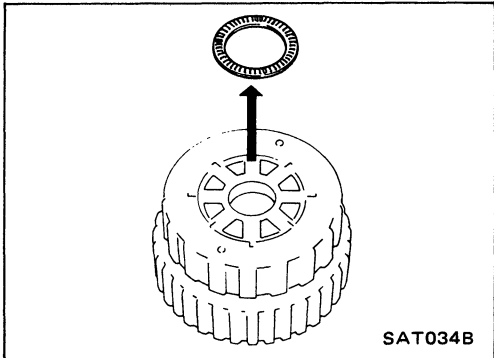

SAT034B

- e. Remove needle bearing from overrun clutch hub.

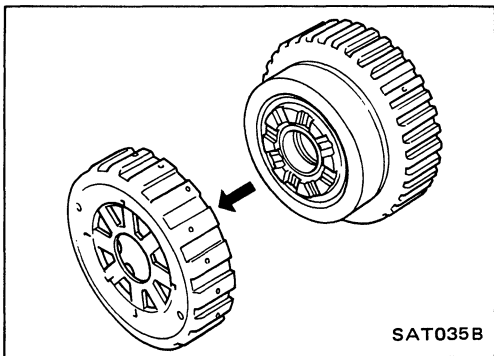

SAT035B

- f. Remove overrun clutch hub from rear internal gear and forward clutch hub.

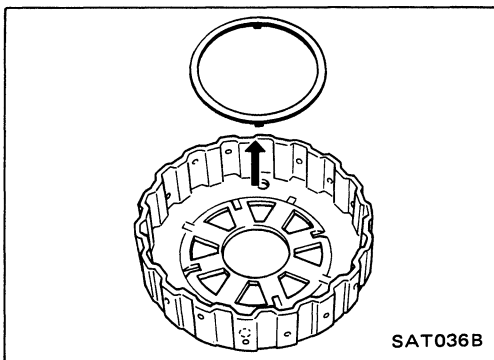

SAT036B

- g. Remove thrust washer from overrun clutch hub.

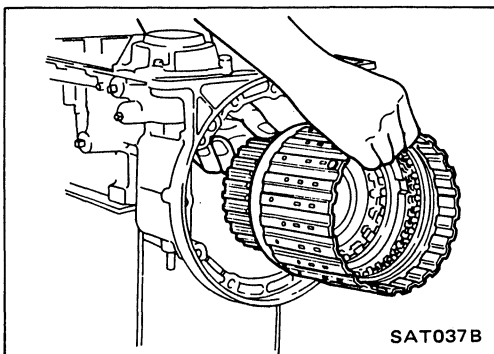

SAT037B

- h. Remove forward clutch assembly from transmission case.

Disassembly (Cont'd)

20. Remove band servo and accumulator components.
 a. Remove band servo retainer from transmission case.

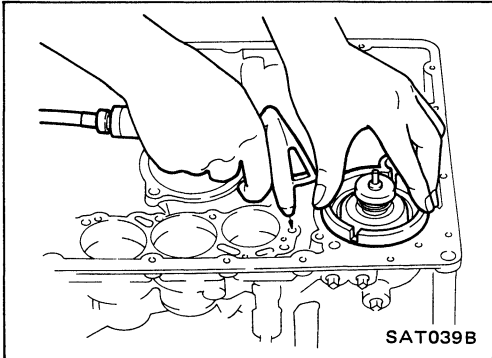
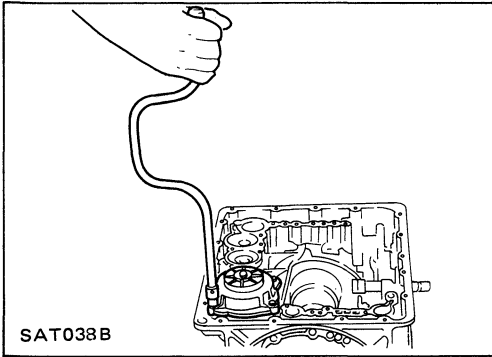

- b. Apply compressed air to oil hole until band servo piston comes out of transmission case.
 ● **Hold piston with a rag and gradually direct air to oil hole.**
 c. Remove return springs.

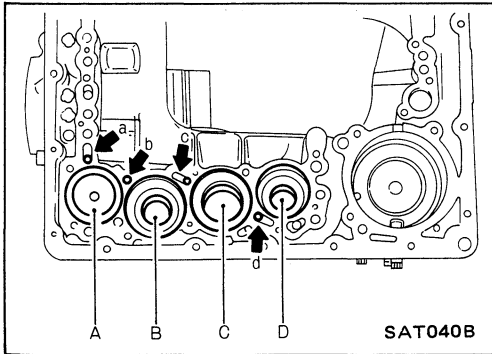

- d. Remove springs from accumulator pistons B, C and D.
 e. Apply compressed air to each oil hole until piston comes out.
 ● **Hold piston with a rag and gradually direct air to oil hole.**

Identification of accumulator pistons	A	B	C	D
Identification of oil holes	a	b	c	d

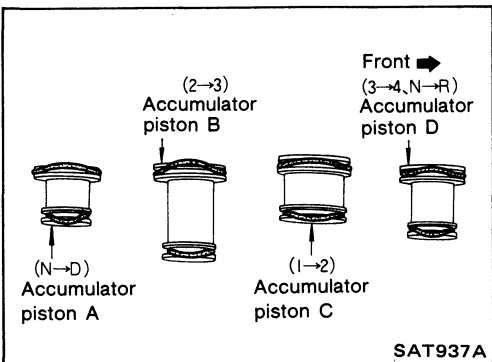

- f. Remove O-ring from each piston.

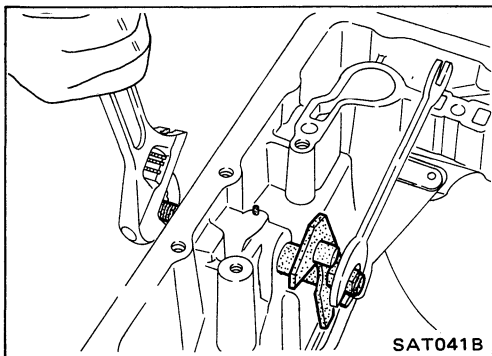

21. Remove manual shaft components, if necessary.
 a. Hold width across flats of manual shaft (outside the transmission case) and remove lock nut from shaft.

Disassembly (Cont'd)

b. Remove retaining pin from transmission case.

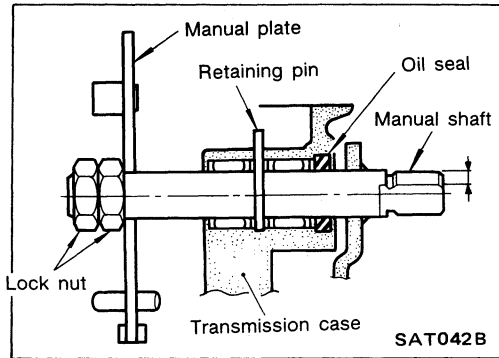

c. While pushing detent spring down, remove manual plate and parking rod from transmission case.

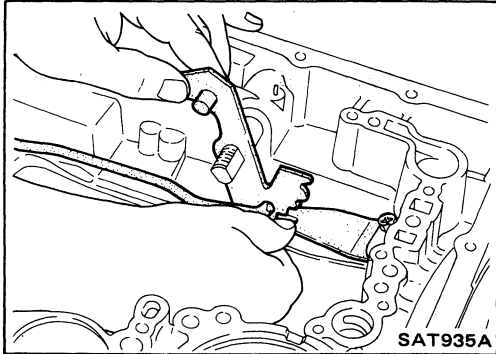

d. Remove manual shaft from transmission case.

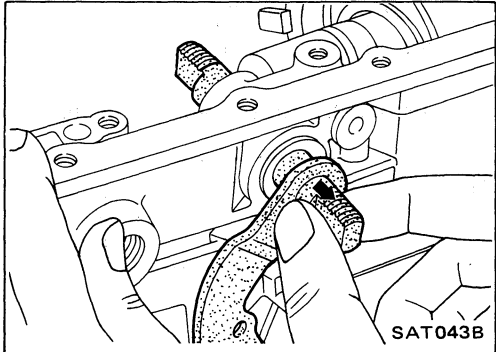

e. Remove spacer and detent spring from transmission case.

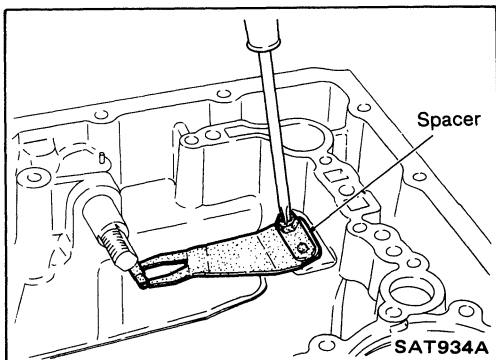

f. Remove oil seal from transmission case.

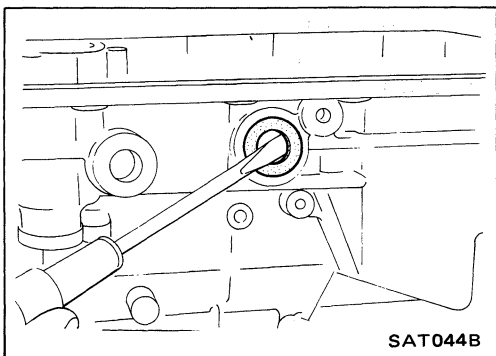

Oil Pump

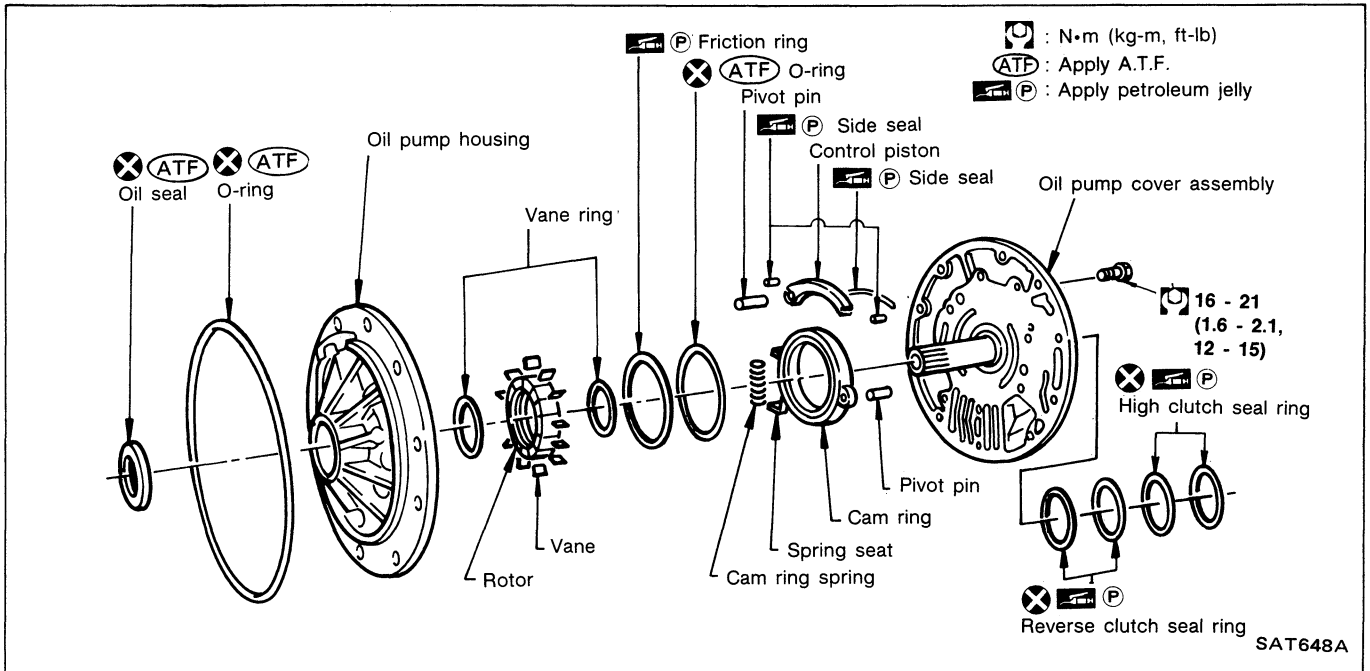

DISASSEMBLY

1. Loosen bolts in numerical order and remove oil pump cover.

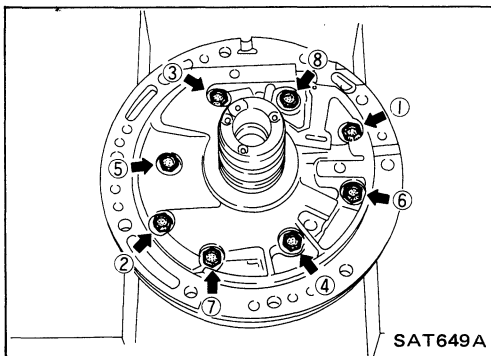

2. Remove rotor, vane rings and vanes.

- Inscribe a mark on back of rotor for identification of fore-aft direction when reassembling rotor. Then remove rotor.

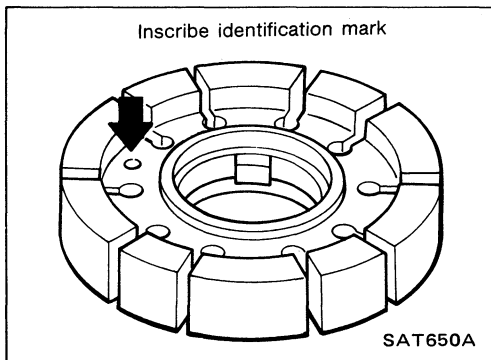

3. While pushing on cam ring remove pivot pin.

- Be careful not to scratch oil pump housing.

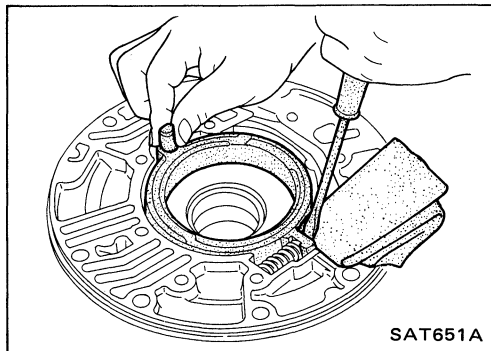

Oil Pump (Cont'd)

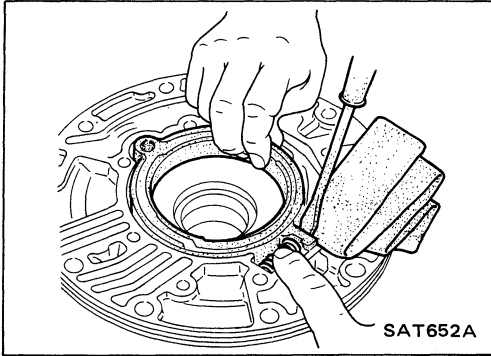

4. While holding cam ring and spring lift out cam ring spring.
- Be careful not to damage oil pump housing.
 - Hold cam ring spring to prevent it from jumping.

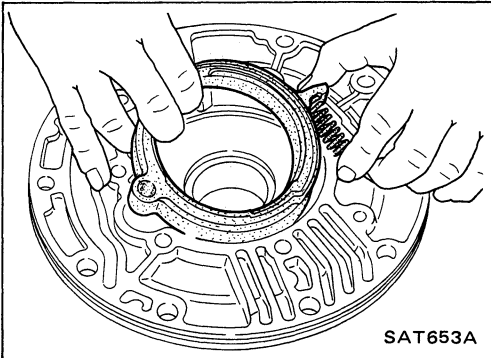

5. Remove cam ring and cam ring spring from oil pump housing.

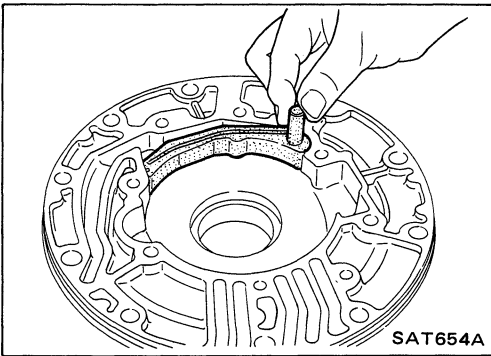

6. Remove pivot pin from control piston and remove control piston assembly.

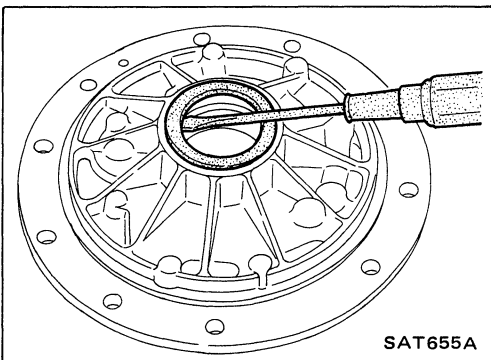

7. Remove oil seal from oil pump housing.
- Be careful not to scratch oil pump housing.

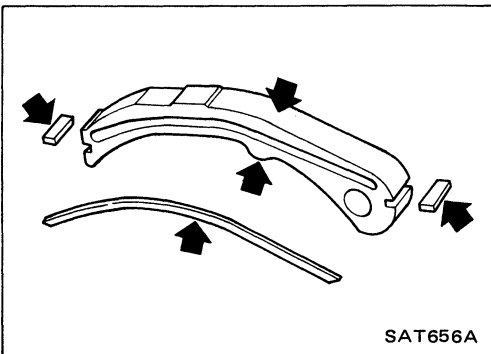

INSPECTION

Oil pump cover, rotor, vanes, control piston, side seals, cam ring and friction ring

- Check for wear or damage.

Oil Pump (Cont'd)

Side clearances

- Measure side clearances between end of oil pump housing and cam ring, rotor, vanes and control piston in at least four places along their circumferences. Maximum measured values should be within specified ranges.
- **Before measuring side clearance, check that friction rings, O-ring, control piston side seals and cam ring spring are removed.**

Standard clearance:

Cam ring

0.01 - 0.024 mm (0.0004 - 0.0009 in)

Rotor, vanes, control piston

0.03 - 0.044 mm (0.0012 - 0.0017 in)

- If not within standard clearance, replace oil pump assembly except oil pump cover assembly.

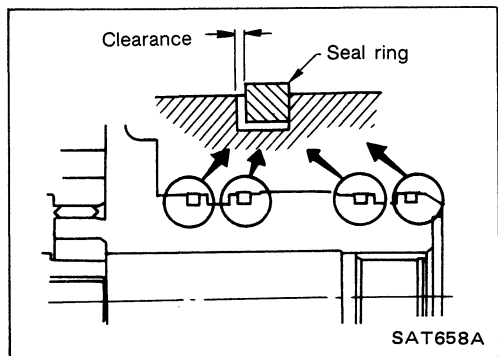
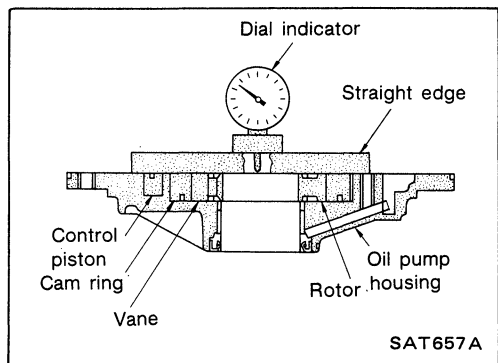

Seal ring clearance

- Measure clearance between seal ring and ring groove.

Standard clearance:

0.10 - 0.25 mm (0.0039 - 0.0098 in)

Wear limit:

0.25 mm (0.0098 in)

- If not within wear limit, replace oil pump cover assembly.

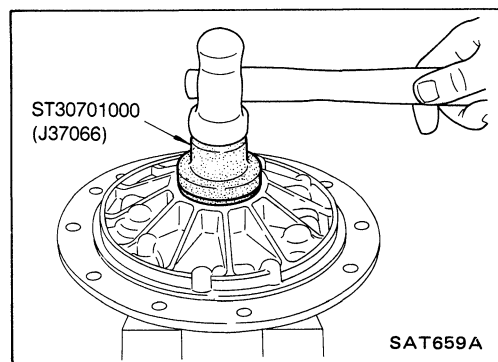

ASSEMBLY

1. Drive oil seal into oil pump housing.

- **Apply A.T.F. to outer periphery and lip surface.**

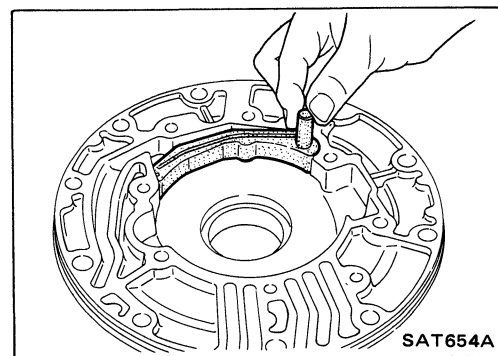

2. Install cam ring in oil pump housing by the following steps.

- a. Install side seal on control piston.

- **Pay attention to its direction — Black surface goes toward control piston.**

- **Apply petroleum jelly to side seal.**

- b. Install control piston on oil pump

Oil Pump (Cont'd)

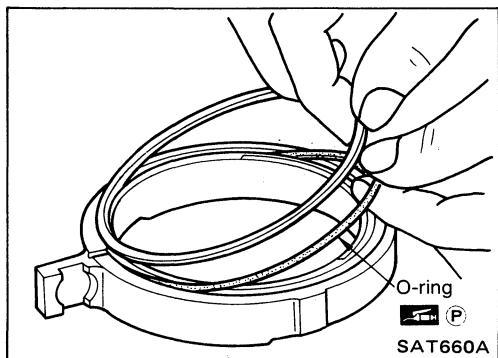

- c. Install O-ring and friction ring on cam ring.
- Apply petroleum jelly to O-ring.

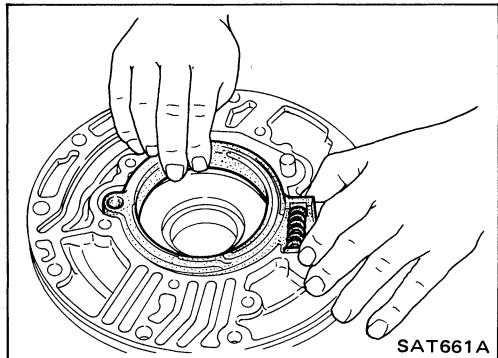

- d. Assemble cam ring, cam ring spring and spring seat. Install spring by pushing it against pump housing.

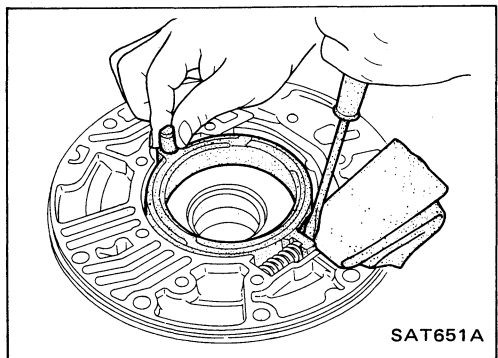

- e. While pushing on cam ring install pivot pin.

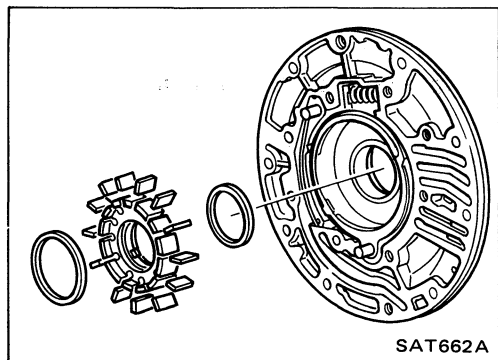

- 3. Install rotor, vanes and vane rings.
- Pay attention to direction of rotor.

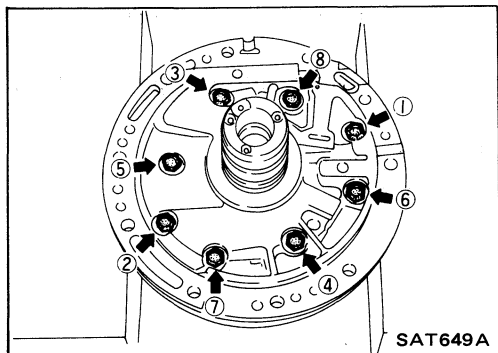

- 4. Install oil pump housing and oil pump cover.
- a. Wrap masking tape around splines of oil pump cover assembly to protect seal. Position oil pump cover assembly in oil pump housing assembly, then remove masking tape.
- b. Tighten bolts in a criss-cross pattern.

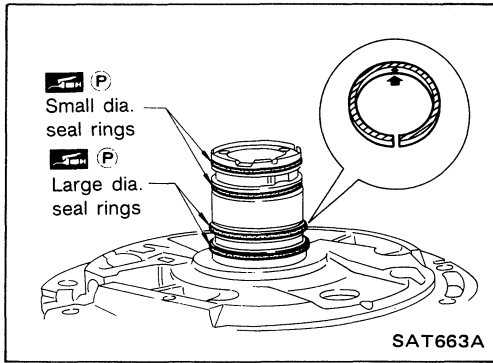

Oil Pump (Cont'd)

5. Install seal rings carefully after packing ring grooves with petroleum jelly. Press rings down into jelly to a close fit.

- Seal rings come in two different diameters. Check fit carefully in each groove.

Small dia. seal ring:

No mark

Large dia. seal ring:

Yellow mark in area shown by arrow

- Do not spread gap of seal ring excessively while installing. It may deform ring.

Control Valve Assembly

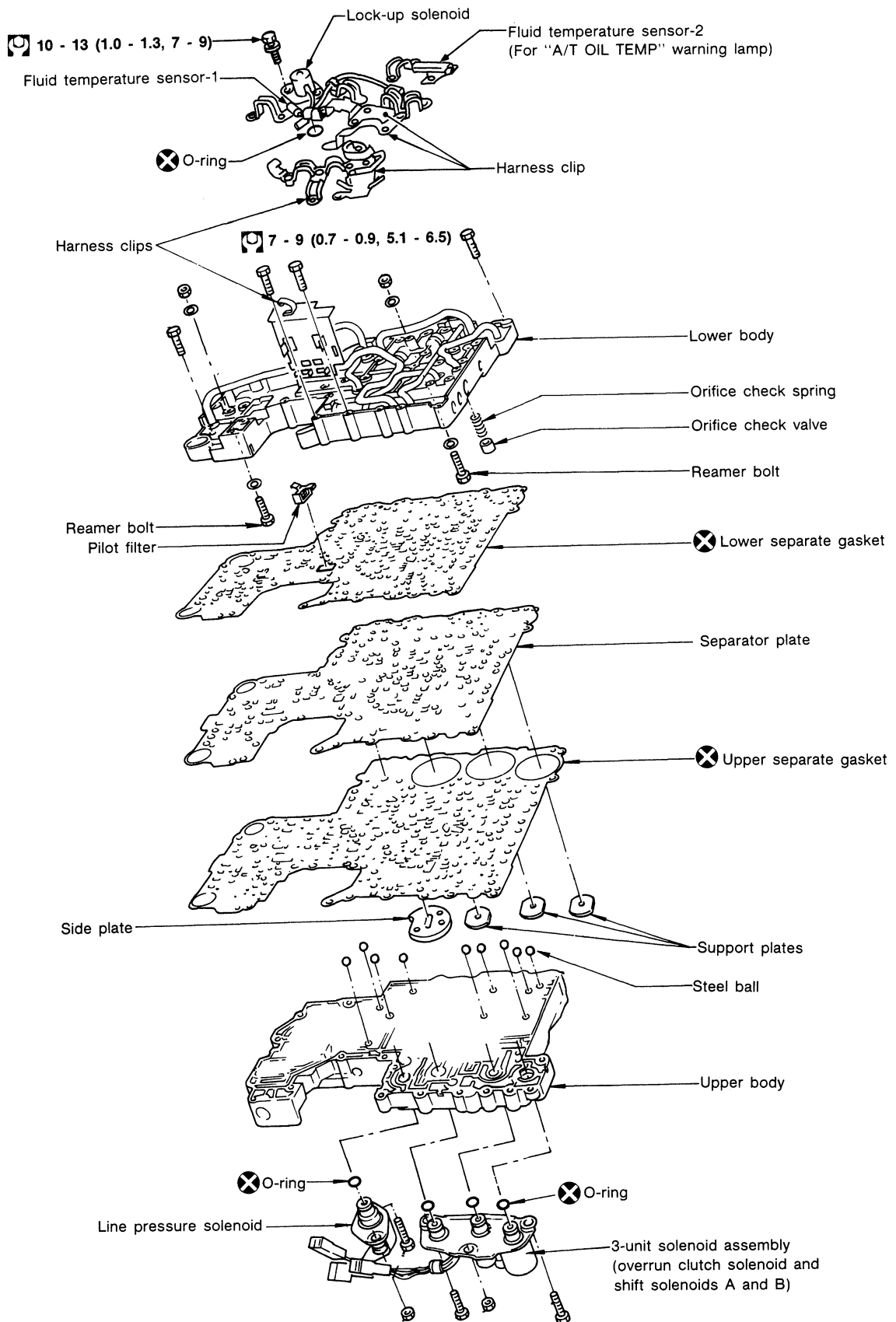

☐ : N·m (kg-m, ft-lb)
SAT665A

Control Valve Assembly (Cont'd)

DISASSEMBLY

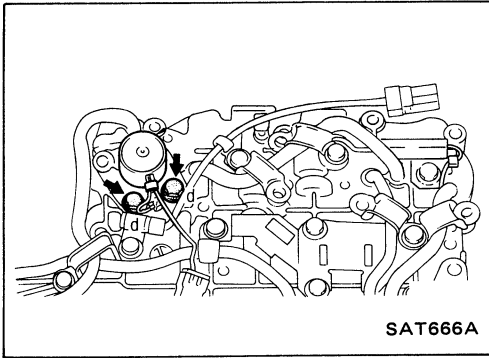

1. Remove solenoids.
 - a. Remove lock-up solenoid and side plate from lower body.
 - b. Remove O-ring from solenoid.

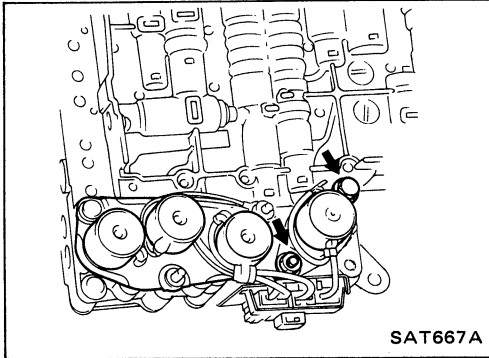

- c. Remove line pressure solenoid from upper body.
 - d. Remove O-ring from solenoid.

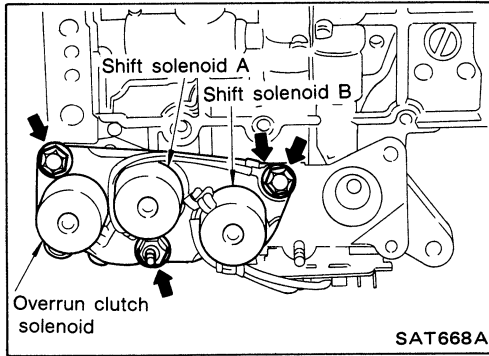

- e. Remove 3-unit solenoid assembly from upper body.
 - f. Remove O-rings from solenoids.

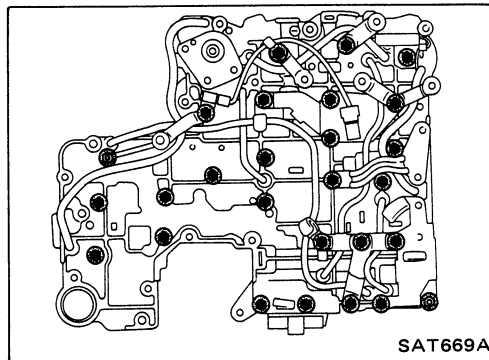

2. Disassemble upper and lower bodies.
 - a. Place upper body facedown, and remove bolts, reamer bolts and support plates.
 - b. Remove lower body, separator plate and separate gasket as a unit from upper body.
 - **Be careful not to drop pilot filter, orifice check valve, spring and steel balls.**

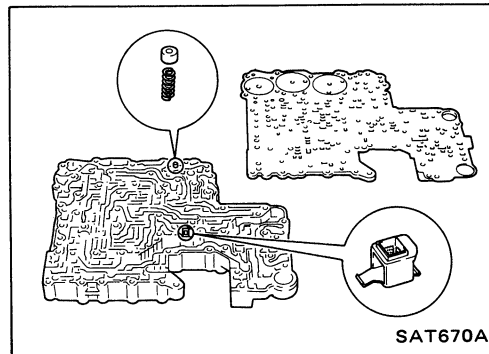

- c. Place lower body facedown, and remove separate gasket and separator plate.
 - d. Remove pilot filter, orifice check valve and orifice check spring.

Control Valve Assembly (Cont'd)

- e. Check to see that steel balls are properly positioned in upper body and then remove them from upper body.

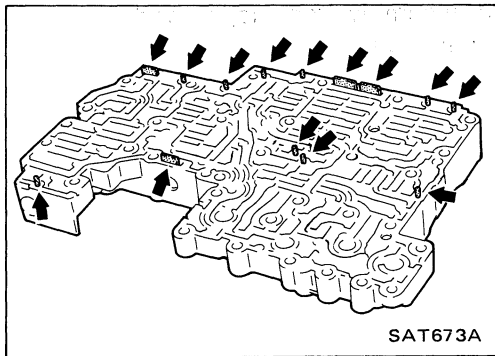
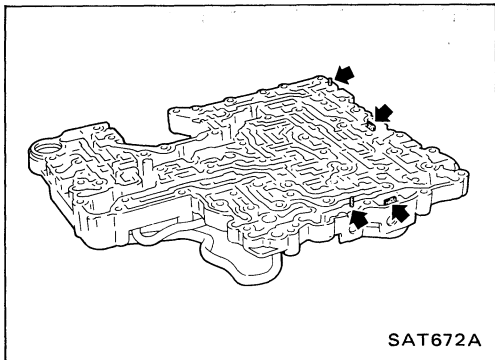
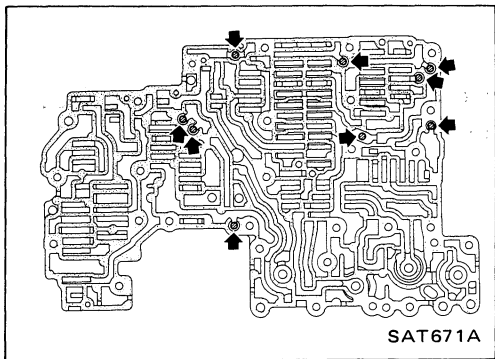

INSPECTION

Lower and upper bodies

- Check to see that there are pins and retainer plates in lower body.

- Check to see that there are pins and retainer plates in upper body.

- **Be careful not to lose these parts.**

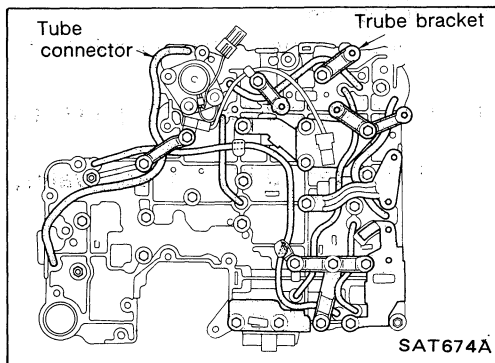

- Check to make sure that oil circuits are clean and free from damage.

- Check tube brackets and tube connectors for damage.

Separator plates

- Check to make sure that separator plate is free of damage and not deformed and oil holes are clean.

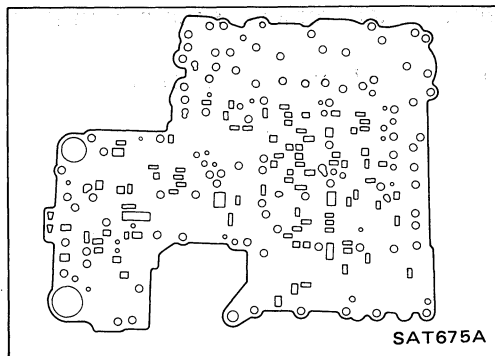

Control Valve Assembly (Cont'd)

Pilot filter

- Check to make sure that filter is not clogged or damaged.

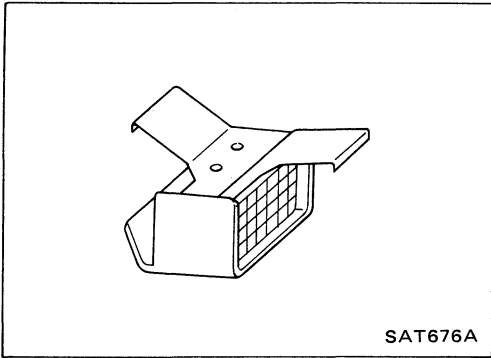

Lock-up solenoid

- Check that filter is not clogged or damaged.
- Measure resistance. — Refer to “Electrical System”.

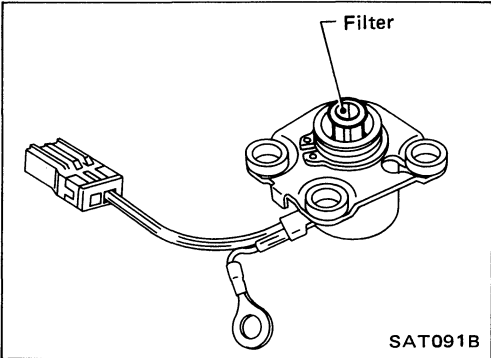

Line pressure solenoid

- Check that filter is not clogged or damaged.
- Measure resistance. — Refer to “Electrical System”.

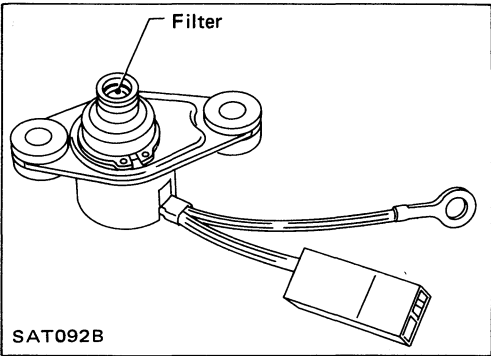

3-unit solenoid assembly (Overrun clutch solenoid and shift solenoids A and B)

- Measure resistance of each solenoid. — Refer to “Electrical System”.

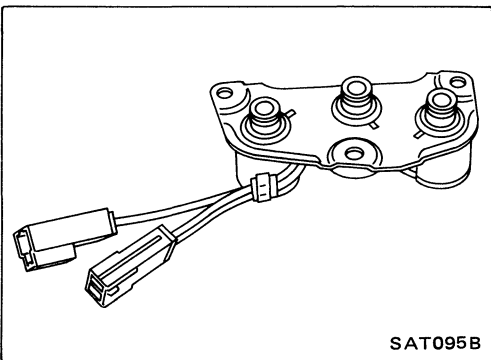

Fluid-temperature sensor -1 and -2

- Measure resistance. — Refer to “Electrical System”.

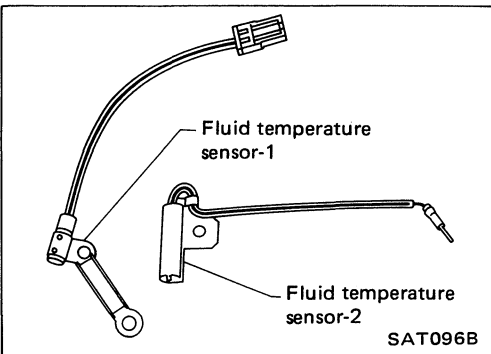

Control Valve Assembly (Cont'd)

ASSEMBLY

1. Install upper and lower bodies.
 - a. Place oil circuit of upper body face up. Install steel balls in their proper positions.

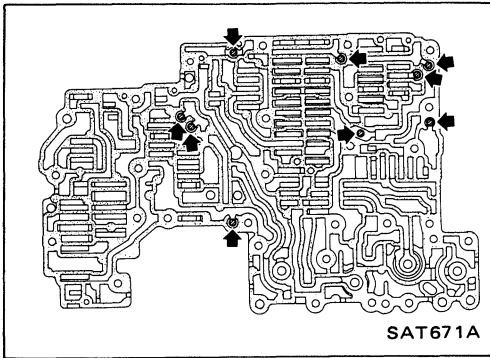

- b. Install reamer bolts from bottom of upper body and install separate gaskets.

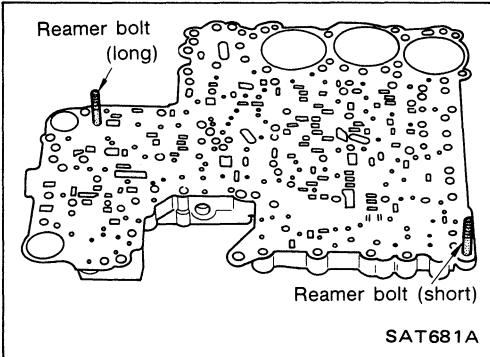

- c. Place oil circuit of lower body face up. Install orifice check spring, orifice check valve and pilot filter.

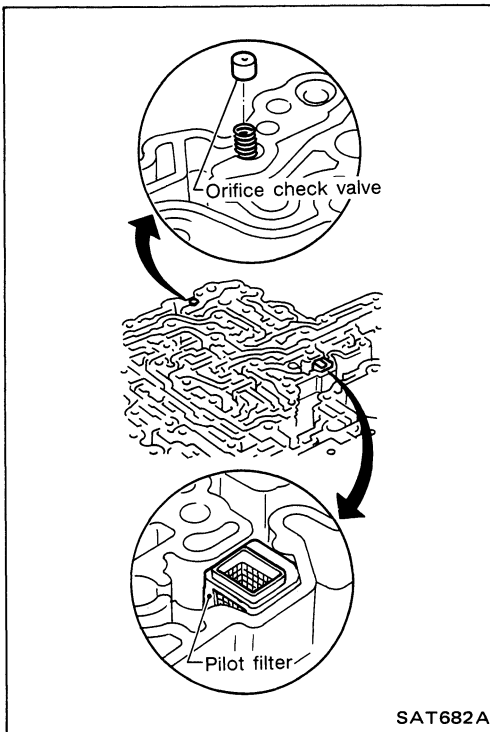

- d. Install lower separate gaskets and separator plates on lower body.
 - e. Install and temporarily tighten support plates, fluid temperature sensor -2 and tube brackets.

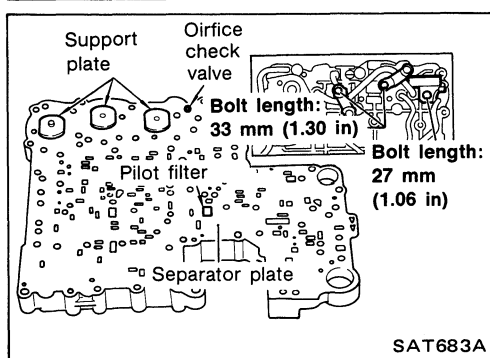

Control Valve Assembly (Cont'd)

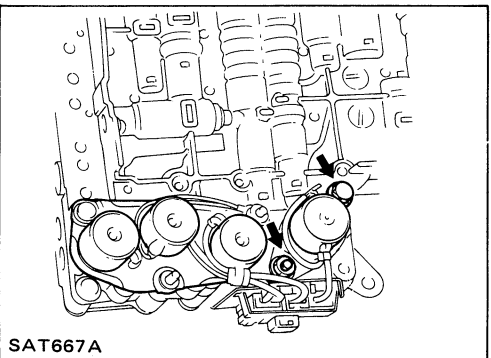
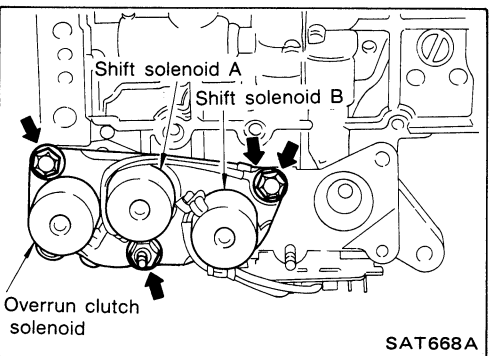
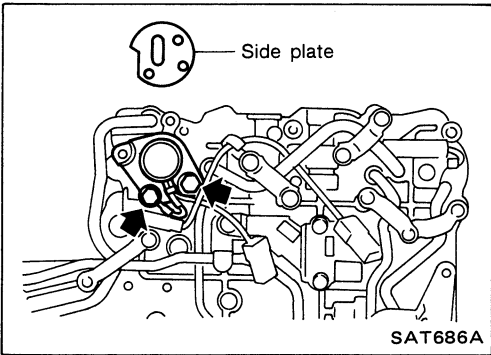
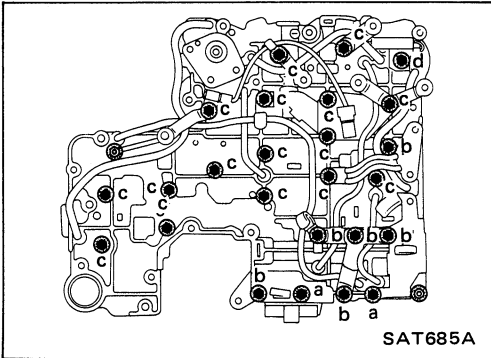
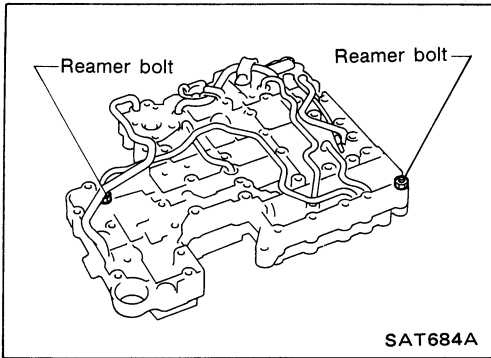

- f. Temporarily assemble lower and upper bodies, using reamer bolt as a guide.
- Be careful not to dislocate or drop steel balls, orifice check spring, orifice check valve and pilot filter.

- g. Install and temporarily tighten bolts and tube brackets in their proper locations.

Bolt length and location

Bolt symbol		a	b	c	d
Item					
Bolt length	mm (in)	70 (2.76)	50 (1.97)	33 (1.30)	27 (1.06)

- 2. Install solenoids.
- a. Attach O-ring and install lock-up solenoid and side plates onto lower body.
- b. Attach O-rings and install 3-unit solenoids assembly onto upper body.
- c. Attach O-ring and install line pressure solenoid onto upper body.
- 3. Tighten all bolts.

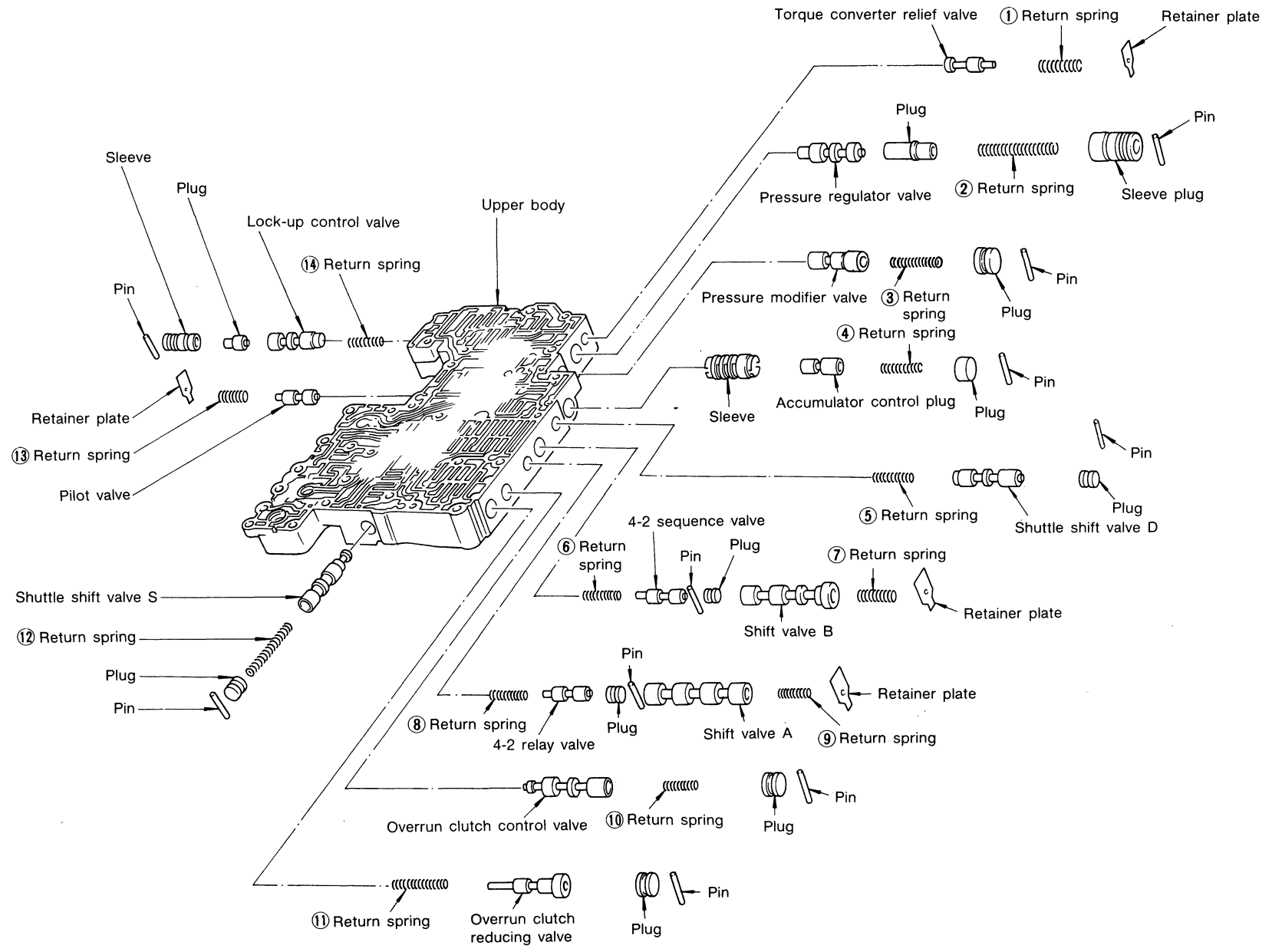

Apply A.T.F. to all components before their installation.

Numbers preceding valve springs correspond with those shown in Spring Chart on page AT-223.

Control Valve Upper Body (Cont'd) DISASSEMBLY

1. Remove valves at parallel pins.
 - Do not use a magnetic hand.

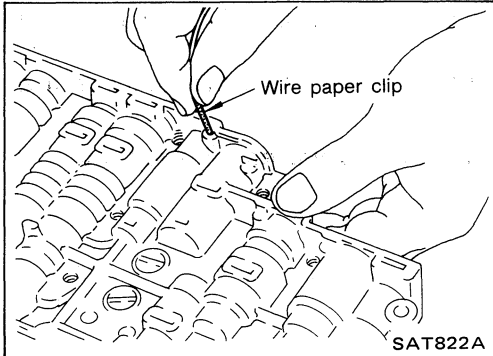
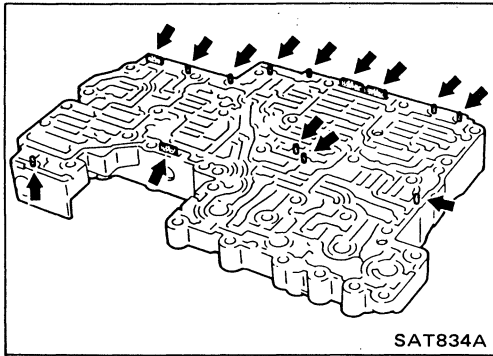

- a. Use a wire paper clip to push out parallel pins.

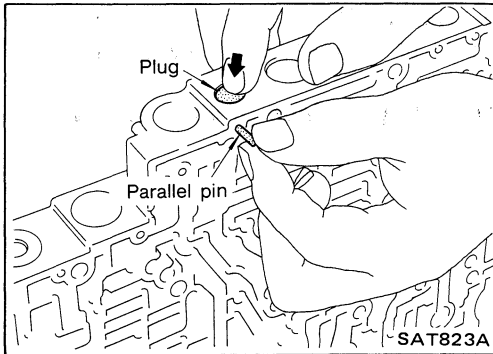

- b. Remove parallel pins while pressing their corresponding plugs and sleeves.
 - Remove plug slowly to prevent internal parts from jumping out.

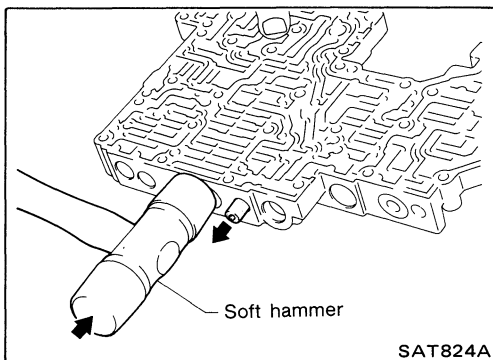

- c. Place mating surface of valve facedown, and remove internal parts.
 - If a valve is hard to remove, place valve body facedown and lightly tap it with a soft hammer.
 - Be careful not to drop or damage valves and sleeves.

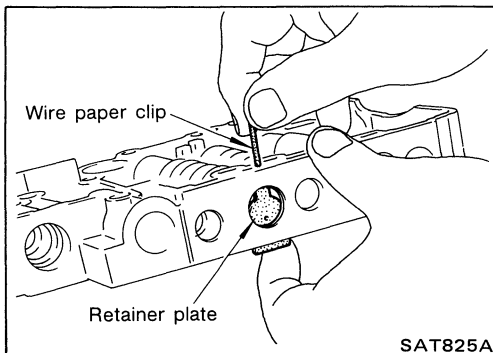

2. Remove valves at retainer plates.
 - a. Pry out retainer plate with wire paper clip.

Control Valve Upper Body (Cont'd)

b. Remove retainer plates while holding spring.

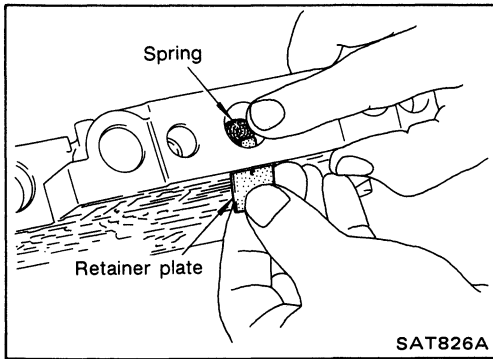

c. Place mating surface of valve facedown, and remove internal parts.

- If a valve is hard to remove, lightly tap valve body with a soft hammer.
- Be careful not to drop or damage valves, sleeves, etc.

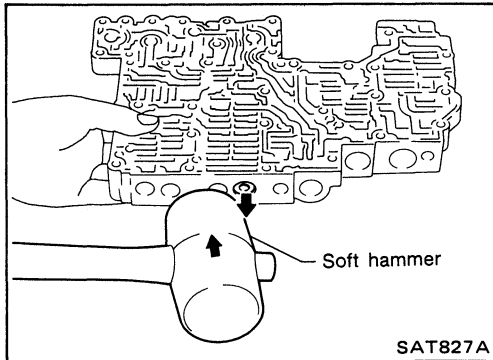

- 4-2 sequence valve and relay valve are located far back in upper body. If they are hard to remove, carefully push them out using stiff wire.
- Be careful not to scratch sliding surface of valve with wire.

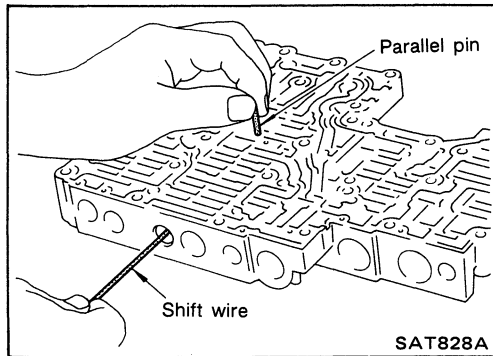

Control Valve Upper Body (Cont'd)
INSPECTION

Valve springs

- Measure free length and outer diameter of each valve spring. Also check for damage or deformation.
- Numbers of each valve spring listed in table below are the same as those in the figure on AT-220.

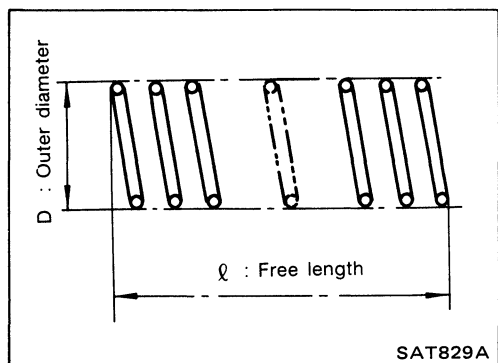

Inspection standard

Unit: mm (in)

Parts	Item	Part No.	ℓ	D
①	Torque converter relief valve spring	31742-41X18	32.3 (1.272)	9.0 (0.354)
②	Pressure regulator valve spring	31742-41X16	61.5 (2.421)	8.9 (0.350)
③	Pressure modifier valve spring	31742-41X19	31.95 (1.2579)	6.8 (0.268)
④	Accumulator control plug spring	31742-41X17	27.5 (1.083)	6.6 (0.260)
⑤	Shuttle shift valve D spring	31762-41X00	26.5 (1.043)	6.0 (0.236)
⑥	4-2 sequence valve spring	31756-41X00	29.1 (1.146)	6.95 (0.2736)
⑦	Shift valve B spring	31762-41X01	25.0 (0.984)	7.0 (0.276)
⑧	4-2 relay valve spring	31756-41X00	29.1 (1.146)	6.95 (0.2736)
⑨	Shift valve A spring	31762-41X01	25.0 (0.984)	7.0 (0.276)
⑩	Overrun clutch control valve spring	31762-41X03	23.6 (0.929)	7.0 (0.276)
⑪	Overrun clutch reducing valve spring	31742-41X20	32.5 (1.280)	7.0 (0.276)
⑫	Shuttle shift valve S spring	31762-41X04	51.0 (2.008)	5.65 (0.2224)
⑬	Pilot valve spring	31742-41X13	25.7 (1.012)	9.1 (0.358)
⑭	Lock-up control valve spring	31742-41X21	33.0 (1.299)	6.5 (0.256)

- Replace valve springs if deformed or fatigued.

Control valves

- Check sliding surfaces of valves, sleeves and plugs.

Control Valve Upper Body (Cont'd)

ASSEMBLY

1. Lubricate the control valve body and all valves with A.T.F. Install control valves by sliding them carefully into their bores.

- Be careful not to scratch or damage valve body.

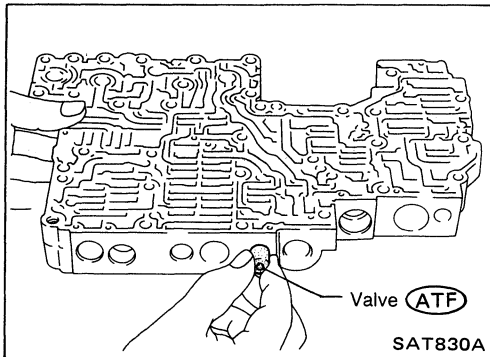

- Wrap a small screwdriver with vinyl tape and use it to insert the valves into proper position.

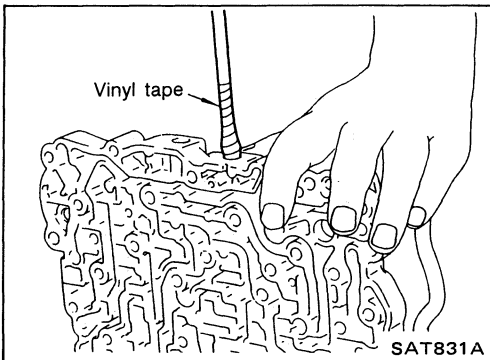

Pressure regulator valve

- If pressure regulator plug is not centered properly, sleeve cannot be inserted into bore in upper body. If this happens, use vinyl tape wrapped screwdriver to center sleeve until it can be inserted.
- Turn sleeve slightly while installing.

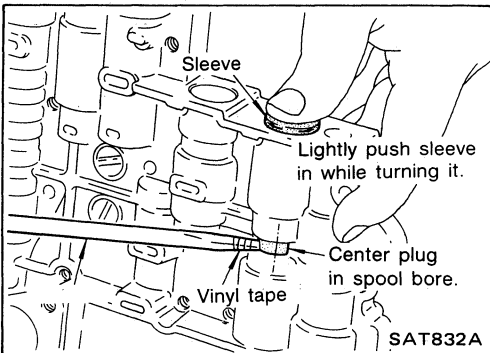

Accumulator control plug

- Align protrusion of accumulator control sleeve with notch in plug.
- Align parallel pin groove in plug with parallel pin, and install accumulator control valve.

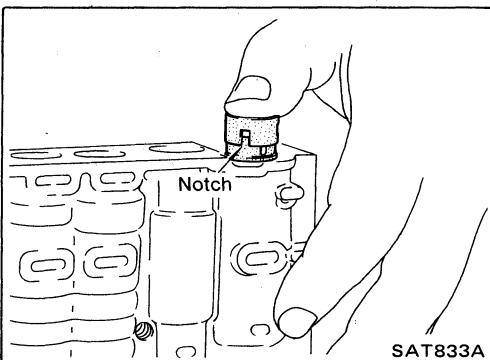

2. Install parallel pins and retainer plates.

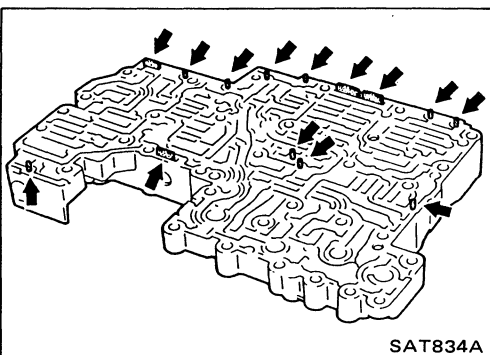

Control Valve Upper Body (Cont'd)

- While pushing plug, install parallel pin.

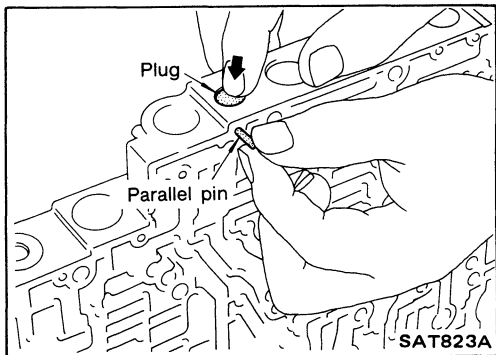

4-2 sequence valve and relay valve

- Push 4-2 sequence valve and relay valve with wire wrapped in vinyl tape to prevent scratching valve body. Install parallel pins.

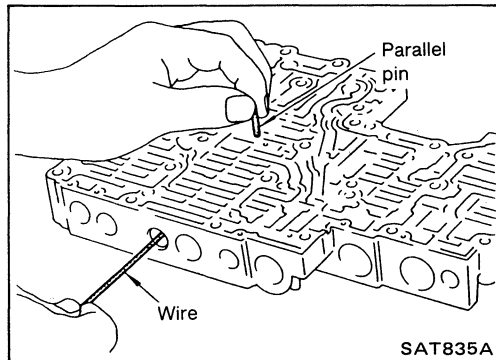

- Insert retainer plate while pushing spring.

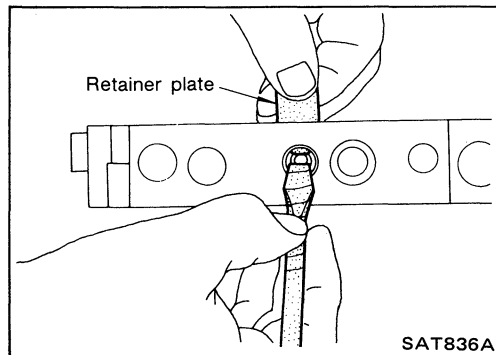

Control Valve Lower Body

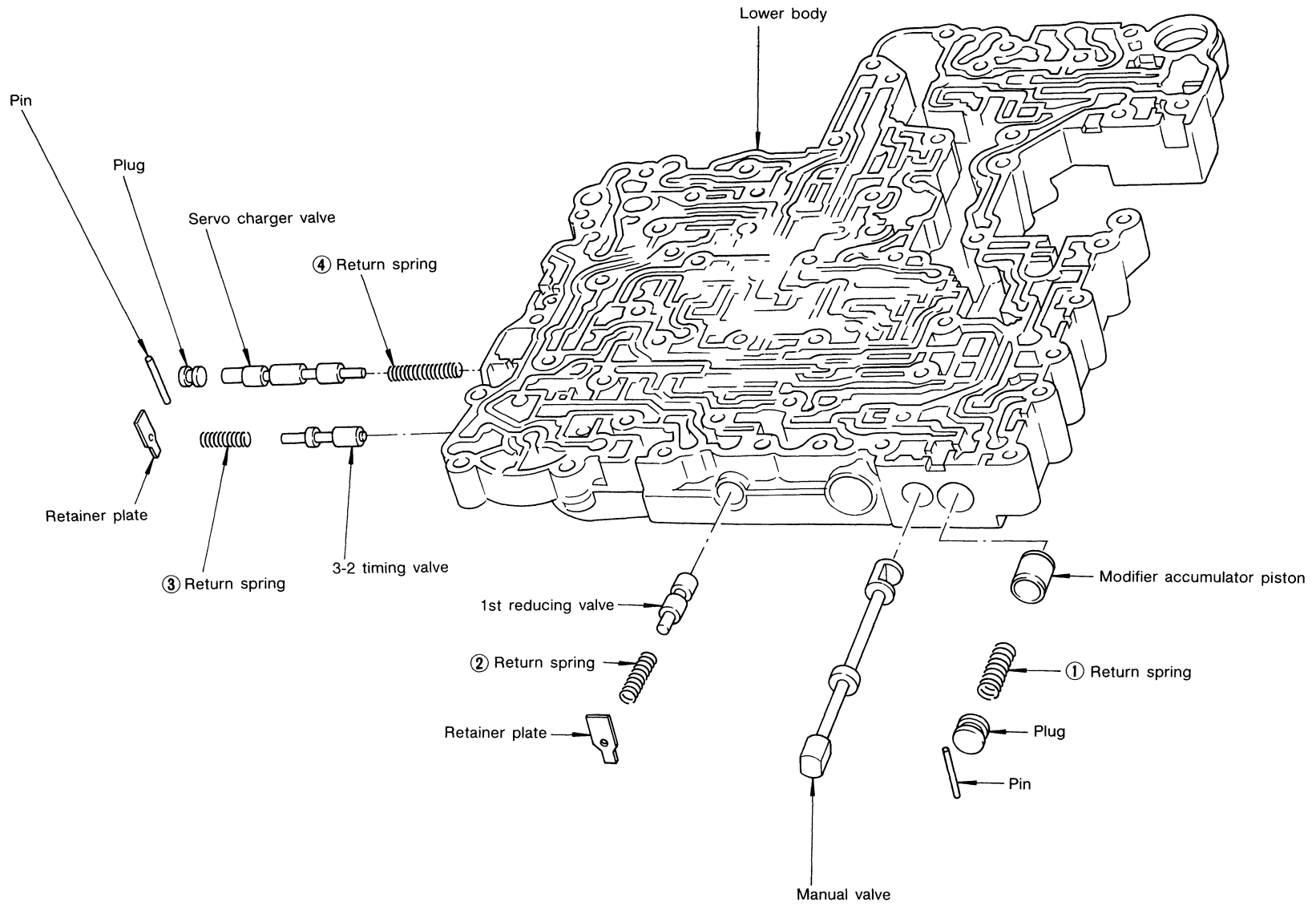

Apply A.T.F. to all components before their installation.

Numbers preceding valve springs correspond with those shown in Spring Chart on page AT-227.

AT-226

SAT837A

**Control Valve Lower Body (Cont'd)
DISASSEMBLY**

1. Remove valves at parallel pins.
2. Remove valves at retainer plates.
For removal procedures, refer to "DISASSEMBLY" of Control Valve Upper Body.

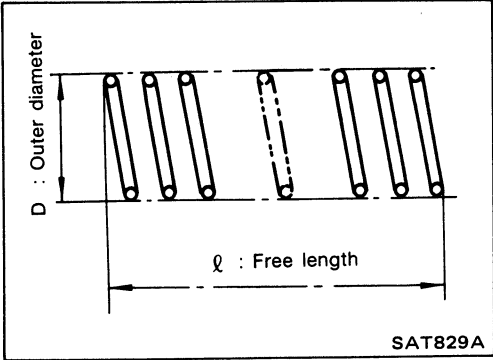
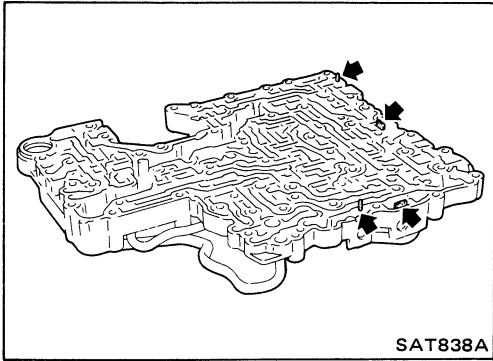

INSPECTION

Valve springs

- Check each valve spring for damage or deformation. Also measure free length and outer diameter.
- Numbers of each valve spring listed in table below are the same as those in the figure on AT-226.

Inspection standard

Unit: mm (in)

Parts	Item	Part No.	l	D
①	Modifier accumulator piston spring	31742-41X15	30.5 (1.201)	9.8 (0.386)
②	1st reducing valve spring	31756-41X05	25.4 (1.000)	6.75 (0.2657)
③	3-2 timing valve spring	31742-41X08	20.55 (0.8091)	6.75 (0.2657)
④	Servo charger valve spring	31742-41X06	23.0 (0.906)	6.7 (0.264)

- Replace valve springs if deformed or fatigued.

Control valves

- Check sliding surfaces of control valves, sleeves and plugs for damage.

ASSEMBLY

- Install control valves.
For installation procedures, refer to "ASSEMBLY" of Control Valve Upper Body.

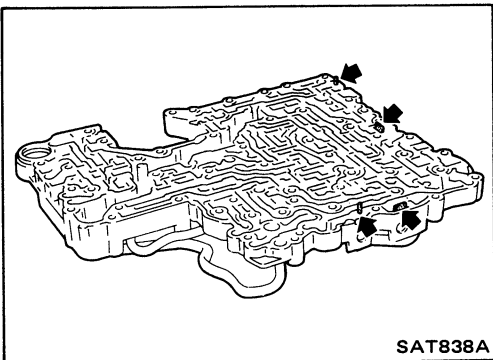

Reverse Clutch

For the number of clutch sheets (drive plate and driven plate), refer to the below cross-section.

(ATF) : Apply A.T.F.
 ★ : Select with proper thickness.

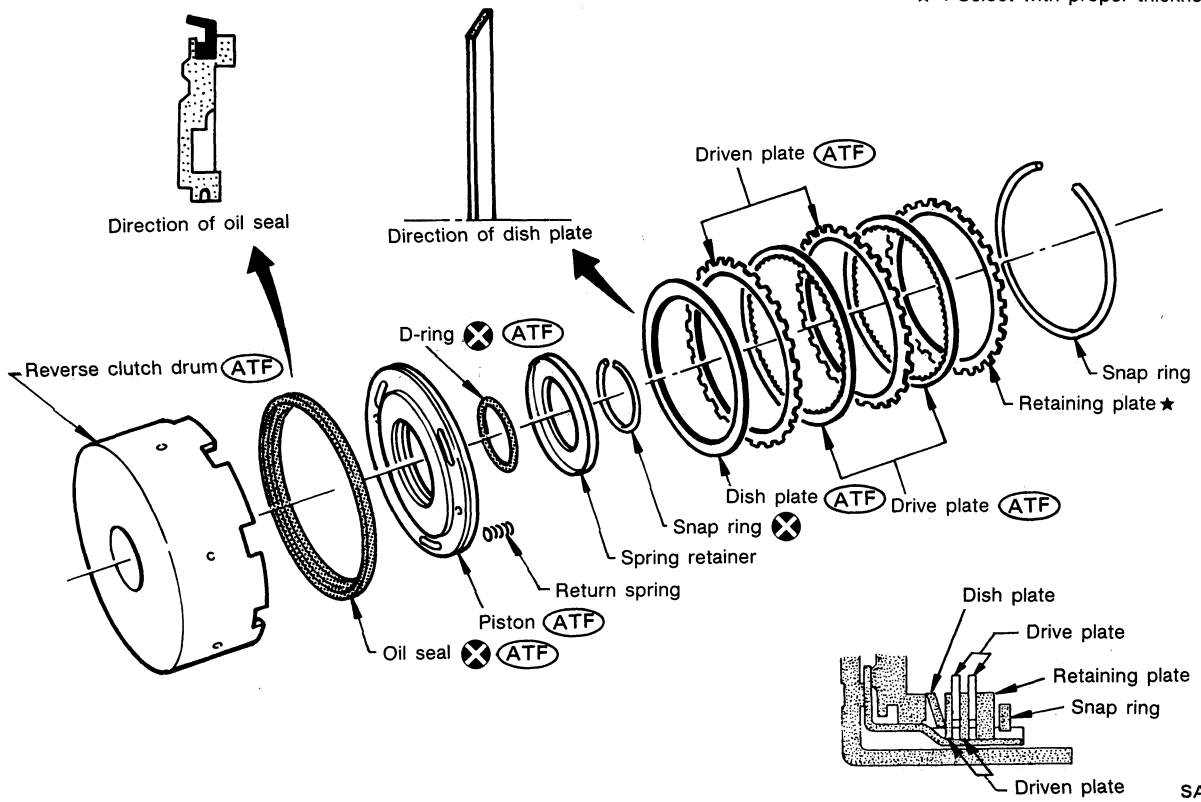

SAT841B

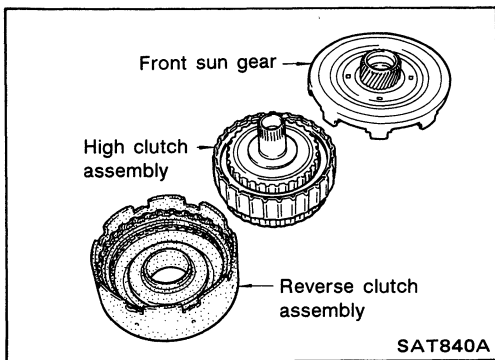

SAT840A

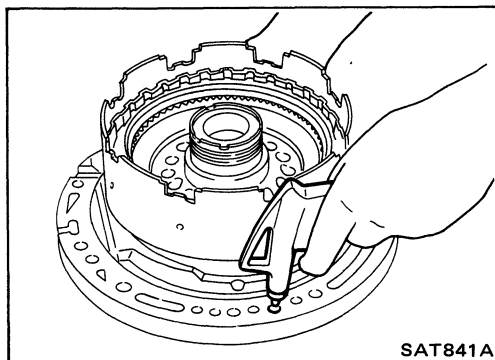

SAT841A

DISASSEMBLY

1. Remove reverse clutch assembly from clutch pack.

2. Check operation of reverse clutch.
- a. Install seal ring onto oil pump cover and install reverse clutch. Apply compressed air to oil hole.
 - b. Check to see that retaining plate moves to snap ring.
 - c. If retaining plate does not move to snap ring, D-ring or oil seal may be damaged or fluid may be leaking at piston check ball.

Reverse Clutch (Cont'd)

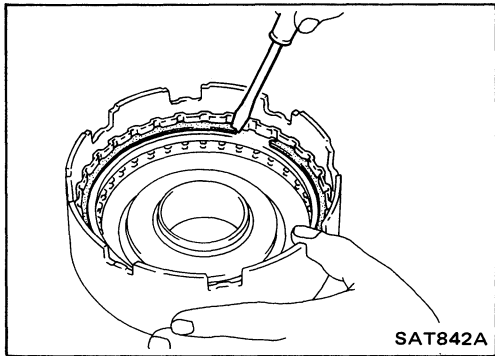

3. Remove drive plates, driven plates, retaining plate, dish plate and snap ring.

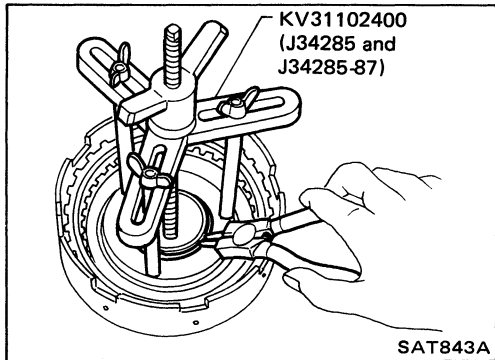

4. Remove snap ring from clutch drum while compressing clutch springs.

- Do not expand snap ring excessively.
5. Remove spring retainer and return spring.

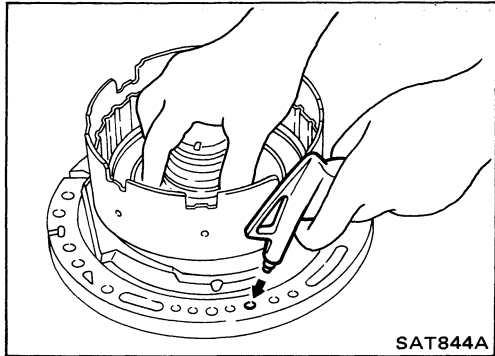

6. Install seal ring onto oil pump cover and install reverse clutch drum. While holding piston, gradually apply compressed air to oil hole until piston is removed.

- Do not apply compressed air abruptly.
7. Remove D-ring and oil seal from piston.

INSPECTION

Reverse clutch snap ring and spring retainer

- Check for deformation, fatigue or damage.

Reverse clutch return springs

- Check for deformation or damage. Also measure free length and outside diameter.

Inspection standard

Unit: mm (in)

Part No.	ℓ	D
31521-21X01	19.69 (0.7752)	11.6 (0.457)

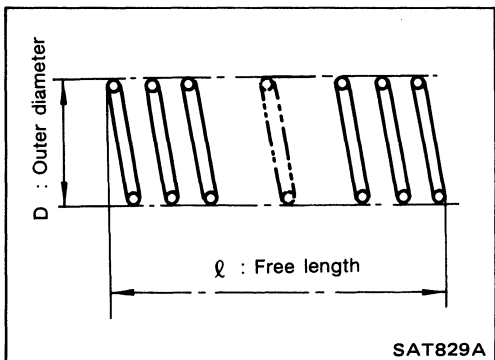

Reverse clutch drive plates

- Check facing for burns, cracks or damage.
- Measure thickness of facing.

Thickness of drive plate:

Standard value: 2.0 mm (0.079 in)

Wear limit: 1.8 mm (0.071 in)

- If not within wear limit, replace.

Reverse clutch dish plate

- Check for deformation or damage.

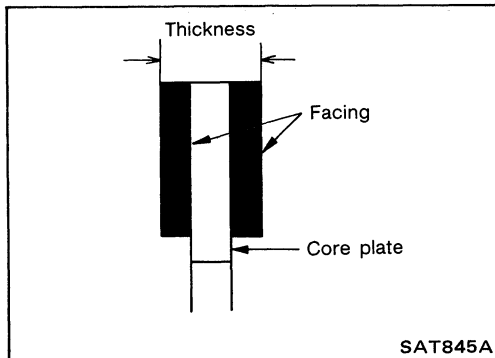

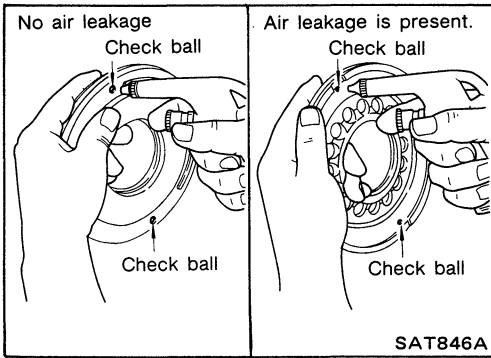

Reverse Clutch (Cont'd)

Reverse clutch piston

- Shake piston to assure that balls are not seized.
- Apply compressed air to check ball oil hole opposite the return spring to assure that there is no air leakage.
- Also apply compressed air to oil hole on return spring side to assure that air leaks past ball.

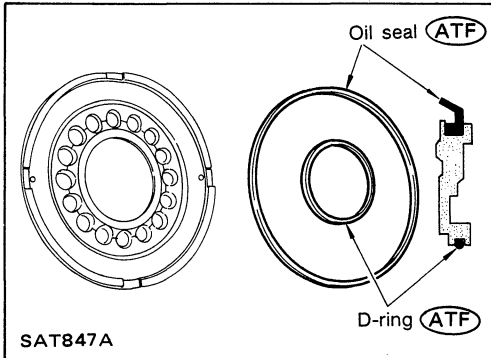

ASSEMBLY

1. Install D-ring and oil seal on piston.
 - Apply A.T.F. to both parts.

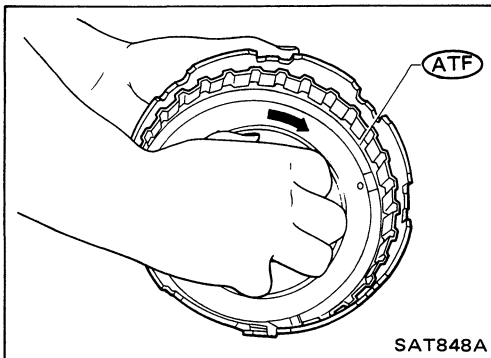

2. Install piston assembly by turning it slowly and evenly.
 - Apply A.T.F. to inner surface of drum.

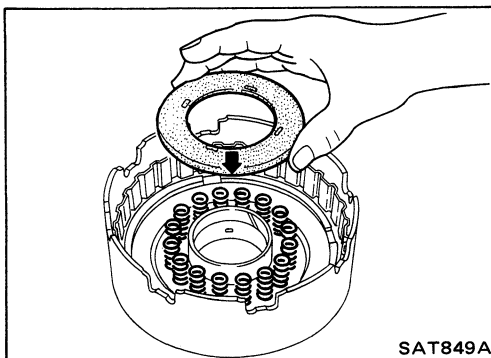

3. Install return springs and spring retainer.

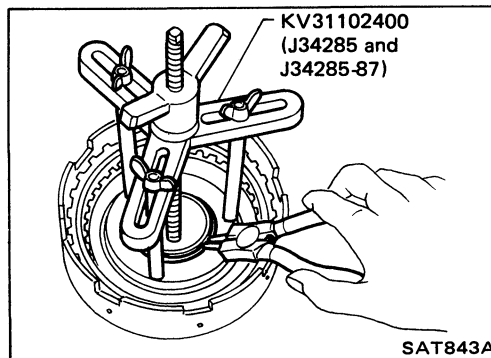

4. Install snap ring while compressing clutch springs.

Reverse Clutch (Cont'd)

- Do not align snap ring gap with spring retainer stopper.

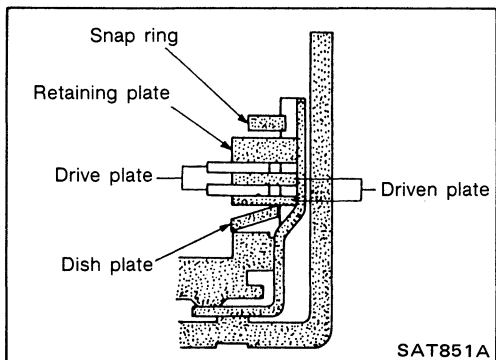
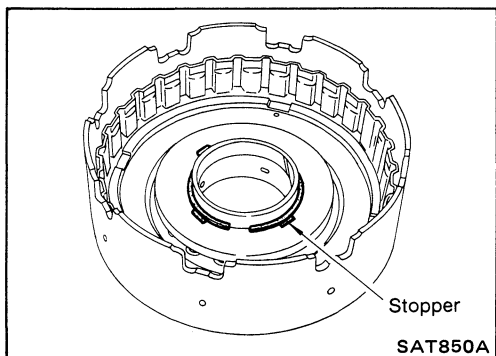

5. Install drive plates, driven plates, retaining plate and dish plate.

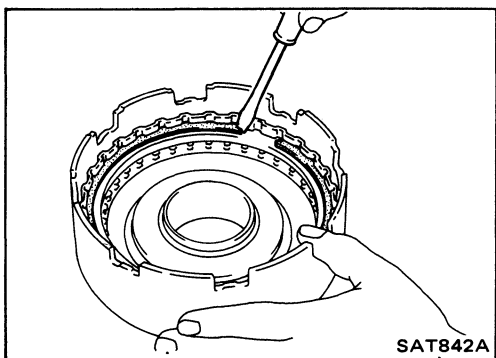

6. Install snap ring.

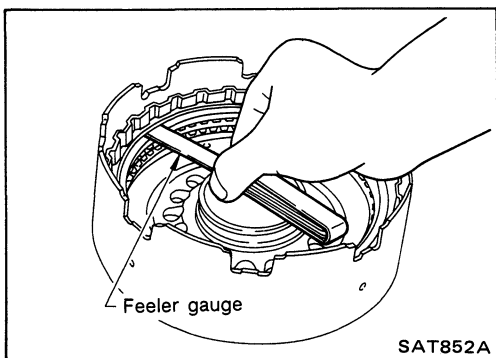

7. Measure clearance between retaining plate and snap ring. If not within allowable limit, select proper retaining plate.

Specified clearance:

Standard

0.5 - 0.8 mm (0.020 - 0.031 in)

Allowable limit

1.2 mm (0.047 in)

Retaining plate:

Refer to S.D.S.

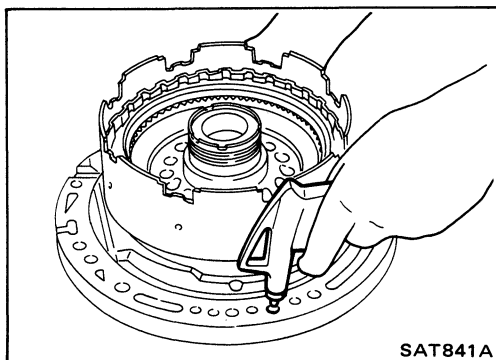

8. Check operation of reverse clutch. Refer to "DISASSEMBLY" of Reverse Clutch.

High Clutch

For the number of clutch sheets (drive plate and driven plate), refer to the below cross-section.

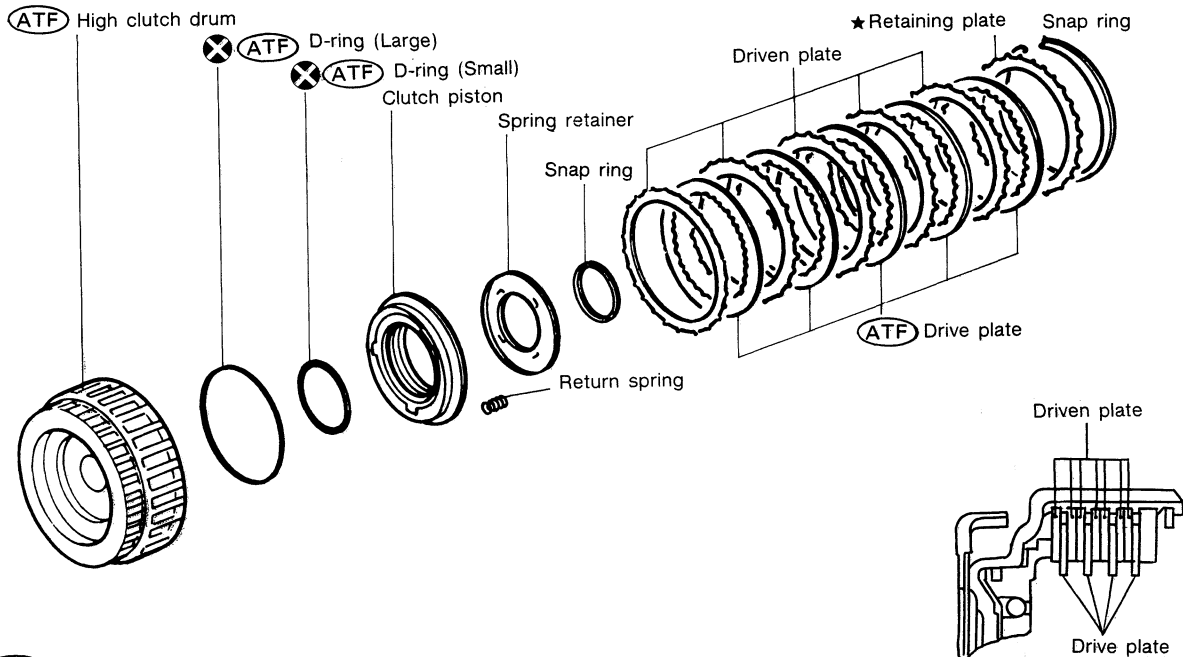

(ATF) : Apply A.T.F.
 ★ : Select with proper thickness.

SAT857A

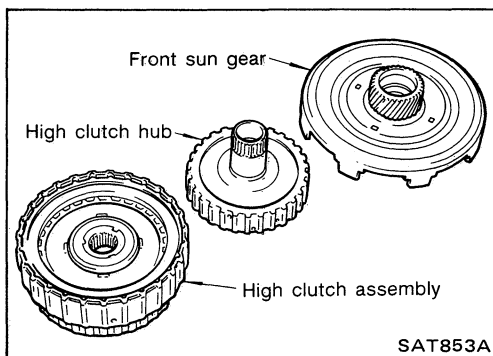

SAT853A

Service procedures for high clutch are essentially the same as those for reverse clutch, with the following exception:

- Check of high clutch operation

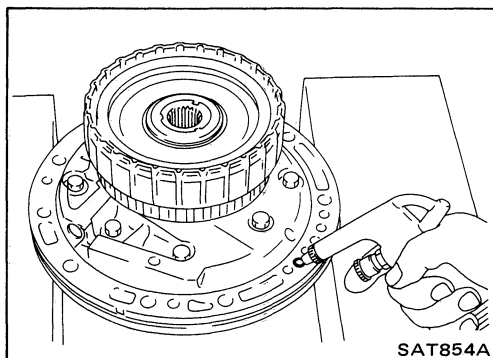

SAT854A

High Clutch (Cont'd)

- Removal and installation of return spring

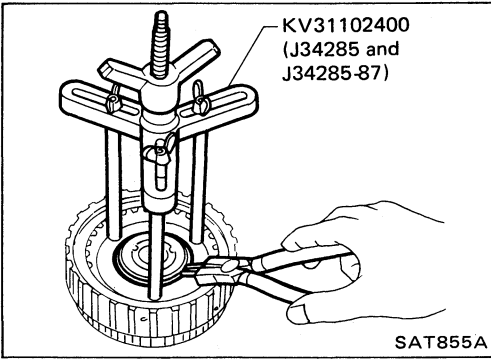

- Inspection of high clutch return springs

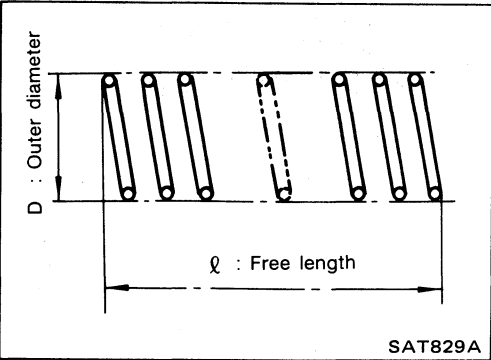

Inspection standard

Unit: mm (in)

Part No.	ℓ	D
31505-21X03	22.06 (0.8685)	11.6 (0.457)

- Inspection of high clutch drive plate

Thickness of drive plate:

Standard

1.6 mm (0.063 in)

Wear limit

1.4 mm (0.055 in)

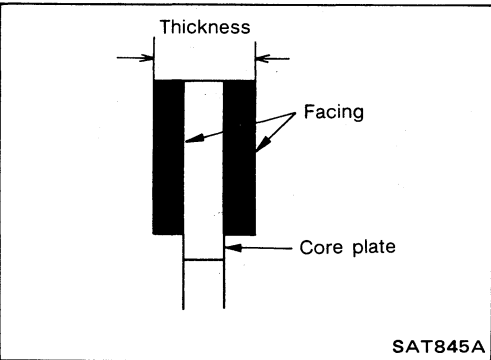

- Measurement of clearance between retaining plate and snap ring

Specified clearance:

Standard

1.8 - 2.2 mm (0.071 - 0.087 in)

Allowable limit

3.0 mm (0.18 in)

Retaining plate:

Refer to S.D.S.

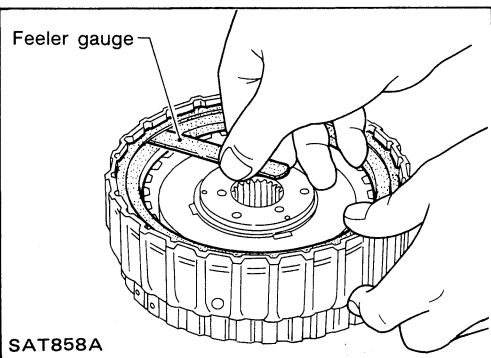

Forward and Overrun Clutches

For the number of clutch sheets (drive plate and driven plate), refer to the below cross-section.

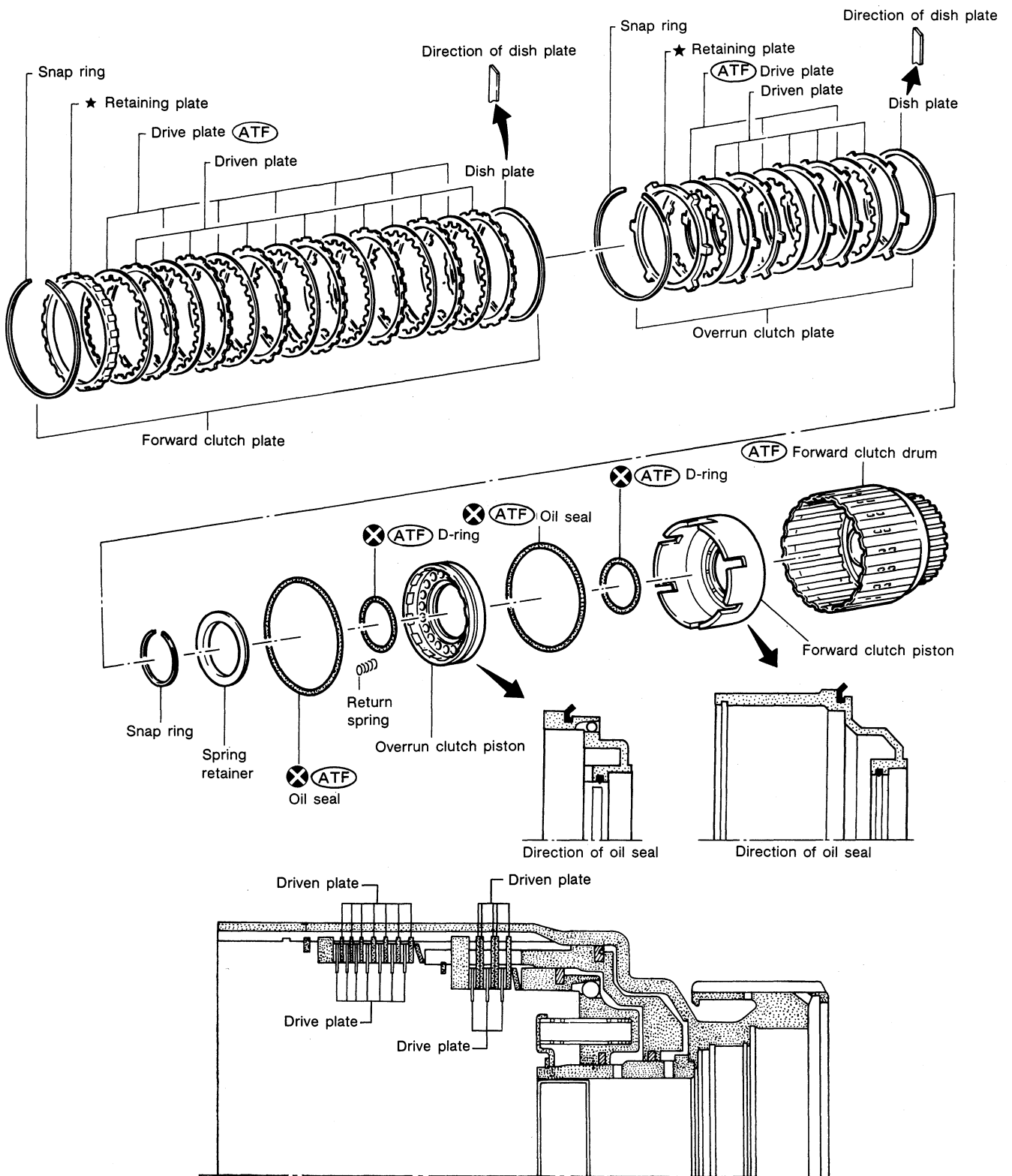

(ATF) : Apply A.T.F.

★ : Select with proper thickness.

Forward and Overrun Clutches (Cont'd)

Service procedures for forward and overrun clutches are essentially the same as those for reverse clutch, with the following exception:

- Check of forward clutch operation.

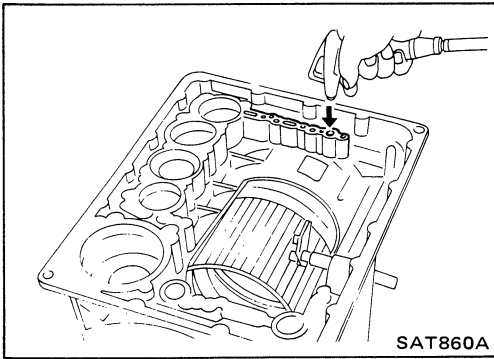

- Check of overrun clutch operation.

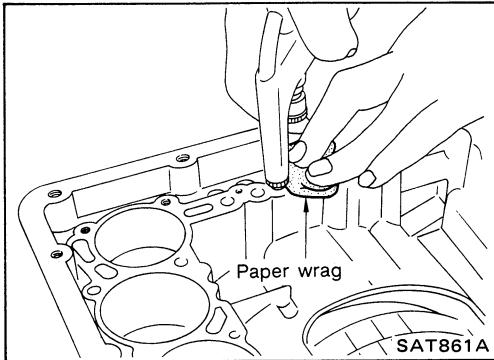

- Removal of forward clutch drum
Remove forward clutch drum from transmission case by holding snap ring.

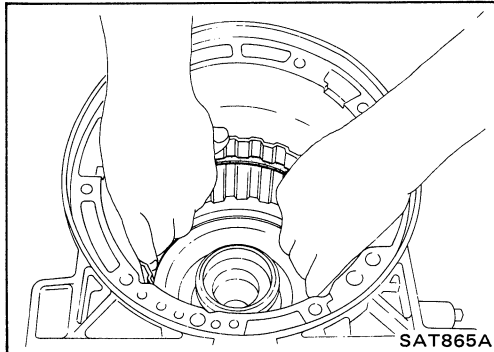

- Removal of forward clutch and overrun clutch pistons
1. While holding overrun clutch piston, gradually apply compressed air to oil hole.

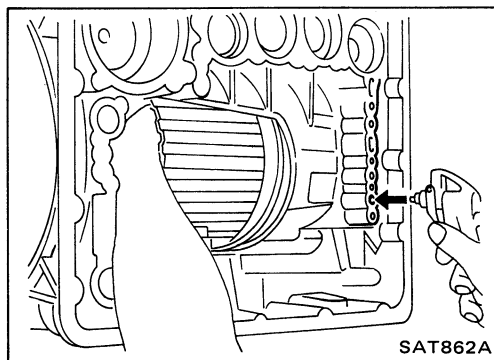

- 2. Remove overrun clutch from forward clutch.

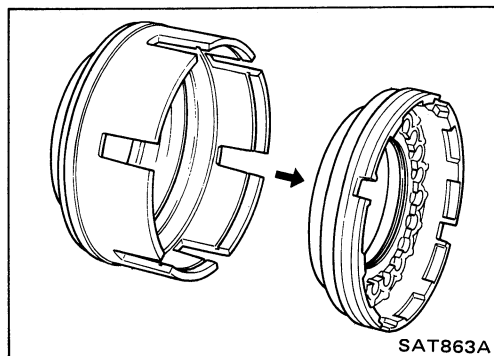

Forward and Overrun Clutches (Cont'd)

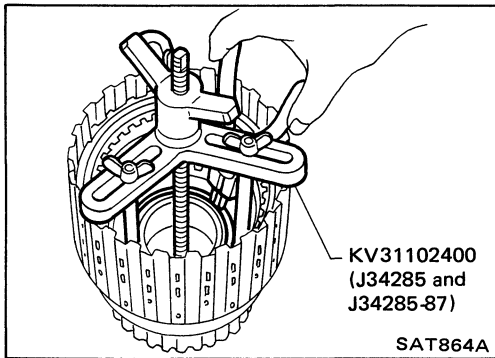

- Removal and installation of return springs

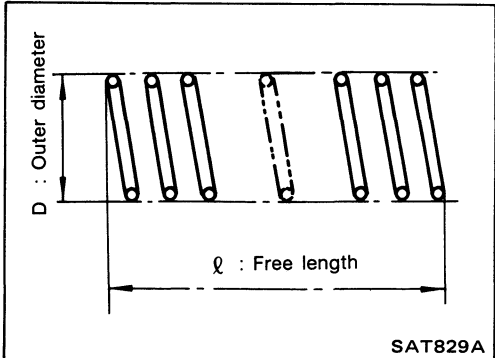

- Inspection of forward clutch and overrun clutch return springs

Inspection standard

Unit: mm (in)

Part No.	ℓ	D
31505-41X01	35.77 (1.4083)	8.0 (0.315)

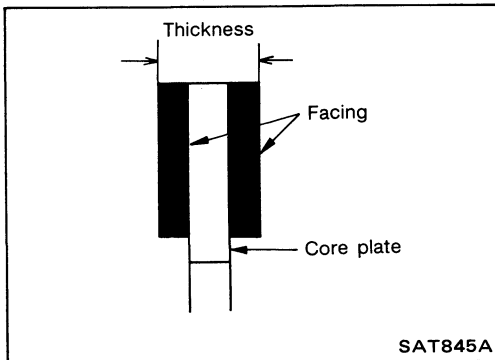

- Inspection of forward clutch drive plates

Thickness of drive plate:

Standard

1.6 mm (0.063 in)

Wear limit

1.4 mm (0.055 in)

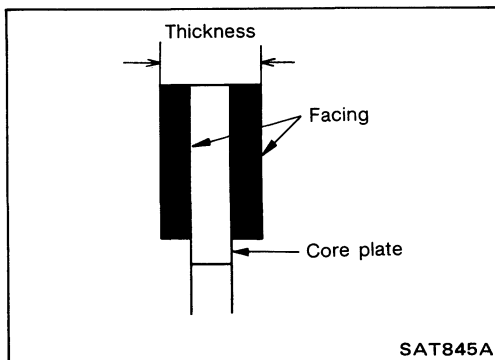

- Inspection of overrun clutch drive plates

Thickness of drive plate:

Standard

2.0 mm (0.079 in)

Wear limit

1.8 mm (0.071 in)

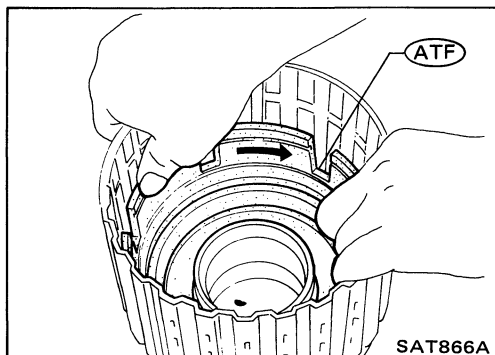

- Installation of forward clutch piston and overrun clutch piston

1. Install forward clutch piston by turning it slowly and evenly.

- **Apply A.T.F. to inner surface of clutch drum.**

Forward and Overrun Clutches (Cont'd)

- Align notch in forward clutch piston with groove in forward clutch drum.

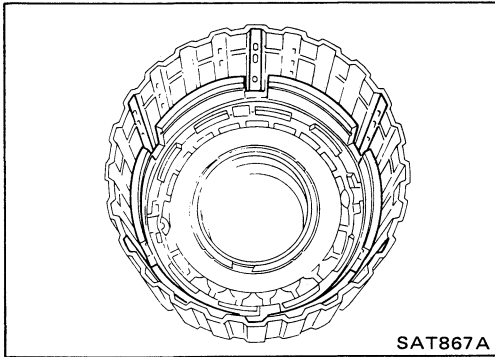

SAT867A

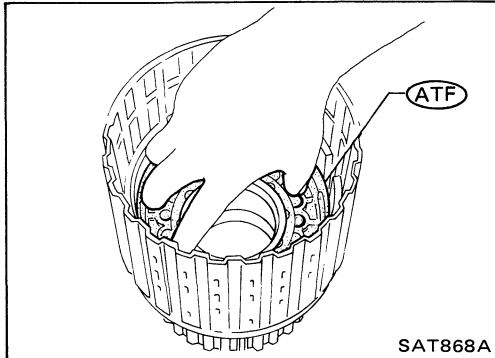

SAT868A

2. Install overrun clutch by turning it slowly and evenly.
- Apply A.T.F. to inner surface of forward clutch piston.

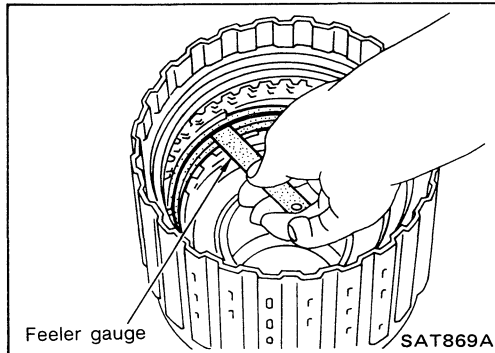

SAT869A

- Measurement of clearance between retaining plate and snap ring of overrun clutch

Specified clearance:

Standard

1.0 - 1.4 mm (0.039 - 0.055 in)

Allowable limit

2.0 mm (0.079 in)

Retaining plate:

Refer to S.D.S.

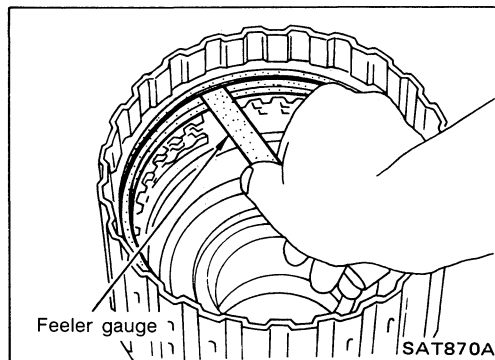

SAT870A

- Measurement of clearance between retaining plate and snap ring of forward clutch

Specified clearance:

Standard

0.45 - 0.85 mm (0.0177 - 0.0335 in)

Allowable limit

2.25 mm (0.0886 in)

Retaining plate:

Refer to S.D.S.

Low & Reverse Brake

For the number of clutch sheets (drive plate and driven plate), refer to the below cross-section.

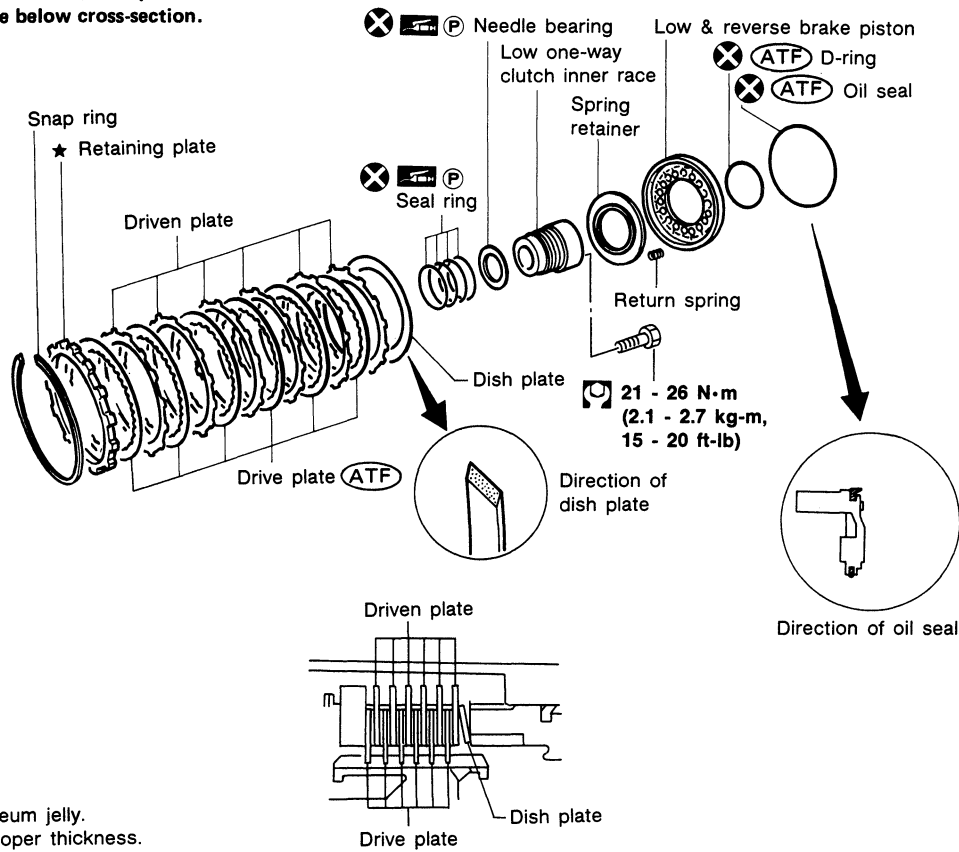

(ATF) : Apply A.T.F.
 (X) (P) : Apply petroleum jelly.
 ★ : Select with proper thickness.

SAT849B

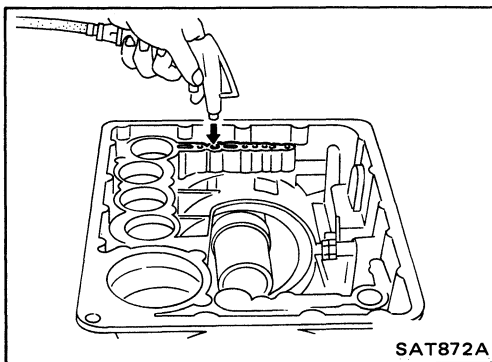

DISASSEMBLY

1. Check operation of low & reverse brake.
 - a. Install seal ring onto oil pump cover and install reverse clutch. Apply compressed air to oil hole.
 - b. Check to see that retaining plate moves to snap ring.
 - c. If retaining plate does not move to snap ring, D-ring or oil seal may be damaged or fluid may be leaking at piston check ball.

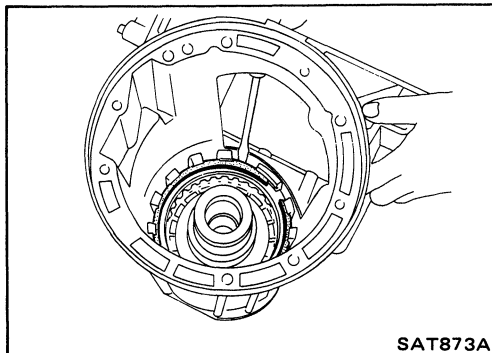

2. Remove snap ring, low & reverse brake drive plates, driven plates and dish plate.

Low & Reverse Brake (Cont'd)

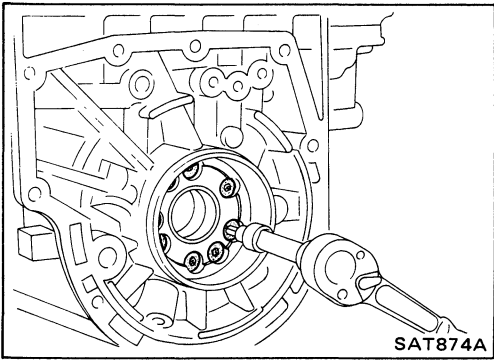

3. Remove low one-way clutch inner race, spring retainer and return spring from transmission case.

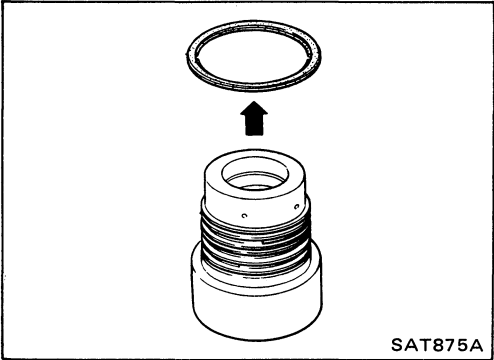

4. Remove seal rings from low one-way clutch inner race.
5. Remove needle bearing from low one-way clutch inner race.

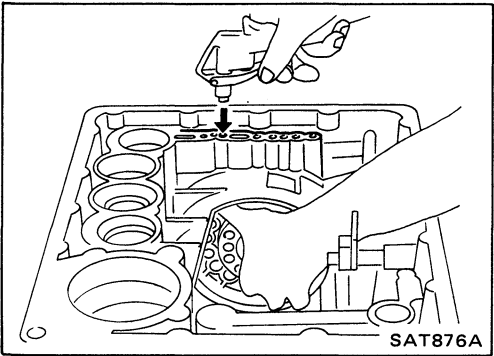

6. Remove low & reverse brake piston using compressed air.
7. Remove oil seal and D-ring from piston.

INSPECTION

Low & reverse brake snap ring and spring retainer

- Check for deformation, or damage.

Low & reverse brake return springs

- Check for deformation or damage. Also measure free length and outside diameter.

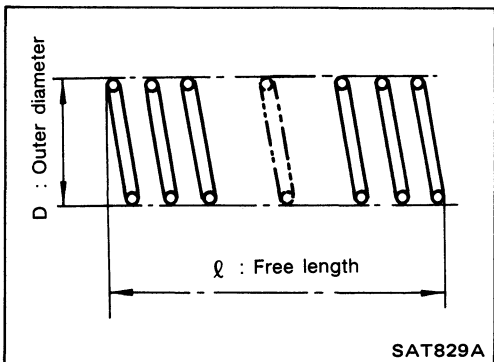

Inspection standard

Unit: mm (in)

Part No.	ℓ	D
31521-21X00	23.7 (0.933)	11.6 (0.457)

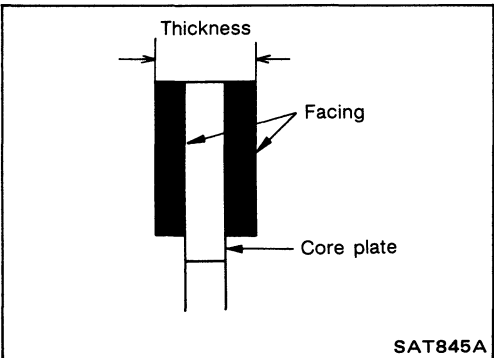

Low & reverse brake drive plates

- Check facing for burns, cracks or damage.
- Measure thickness of facing.

Thickness of drive plate:

Standard value

2.0 mm (0.079 in)

Wear limit

1.8 mm (0.071 in)

- If not within wear limit, replace.

Low & Reverse Brake (Cont'd)

Low one-way clutch inner race

- Check frictional surface of inner race for wear or damage.

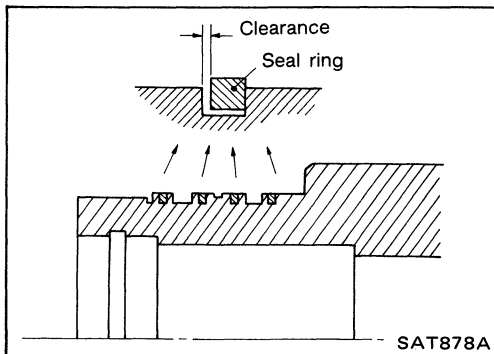
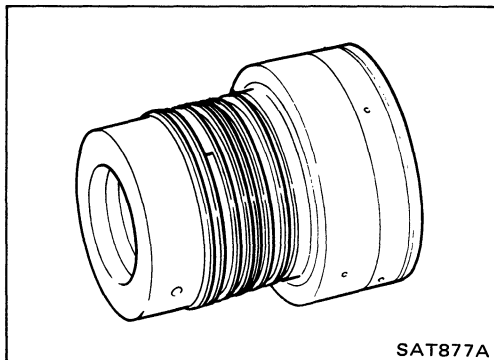

- Install a new seal rings onto low one-way clutch inner race.
- **Be careful not to expand seal ring gap excessively.**
- Measure seal ring-to-groove clearance.

Inspection standard:

Standard value: 0.10 - 0.25 mm (0.0039 - 0.0098 in)

Allowable limit: 0.25 mm (0.0098 in)

- If not within allowable limit, replace low one-way clutch inner race.

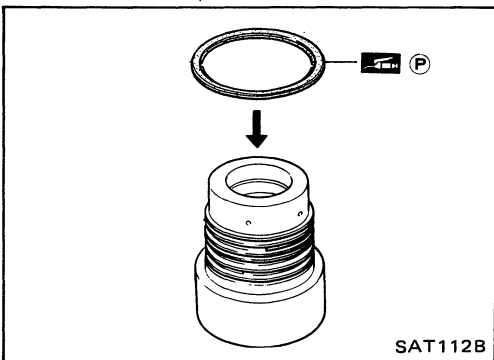

ASSEMBLY

1. Install bearing onto one-way clutch inner race.
 - **Pay attention to its direction — Black surface goes to rear side.**
 - **Apply petroleum jelly to needle bearing.**

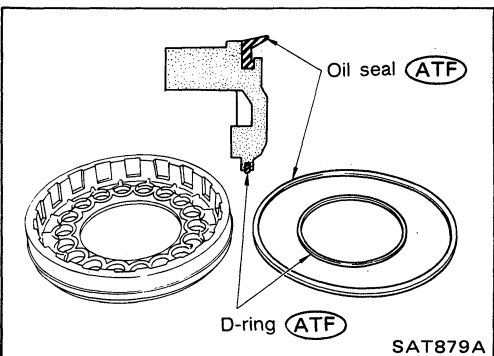

2. Install oil seal and D-ring onto piston.
 - **Apply A.T.F. to oil seal and D-ring.**

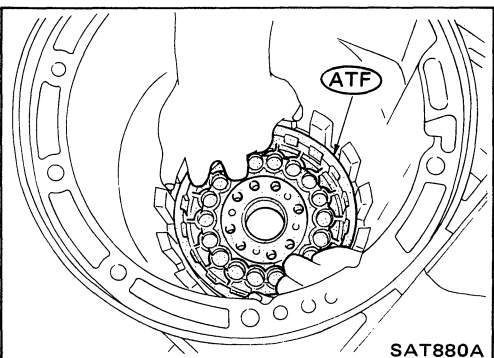

3. Install piston by rotating it slowly and evenly.
 - **Apply A.T.F. to inner surface of transmission case.**

Low & Reverse Brake (Cont'd)

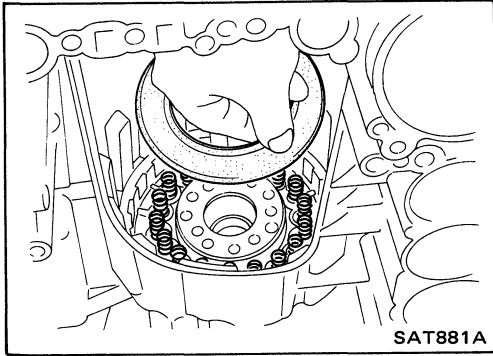

4. Install return springs, spring retainer and low one-way clutch inner race onto transmission case.

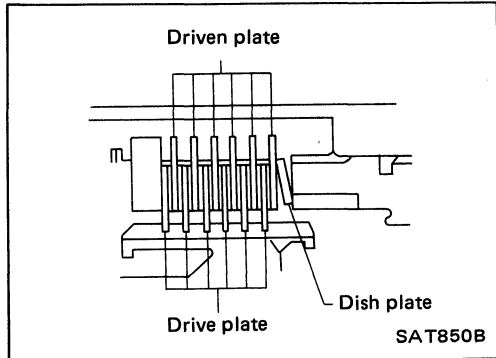

5. Install dish plate low & reverse brake drive plates, driven plates and retaining plate.
6. Install snap ring on transmission case.

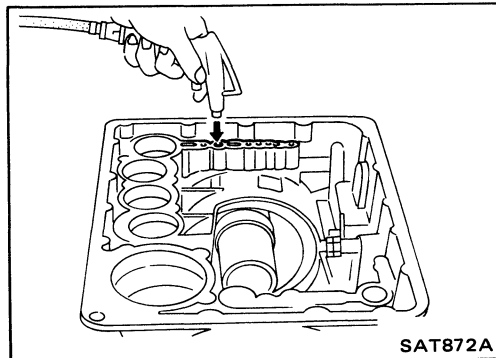

7. Check operation of low & reverse brake clutch piston. Refer to "DISASSEMBLY".

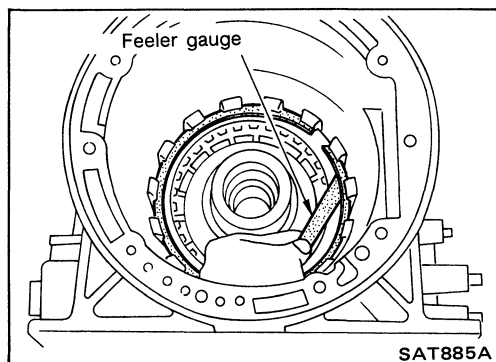

8. Measure clearance between retaining plate and snap ring. If not within allowable limit, select proper retaining plate.

Specified clearance:

Standard

1.1 - 1.5 mm (0.043 - 0.059 in)

Allowable limit

2.7 mm (0.106 in)

Retaining plate:

Refer to S.D.S.

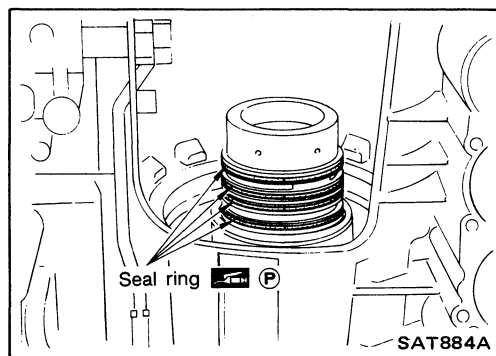

9. Install low one-way clutch inner race seal ring.
 - Apply petroleum jelly to seal ring.
 - Make sure seal rings are pressed firmly into place and held by petroleum jelly.

Forward Clutch Drum Assembly

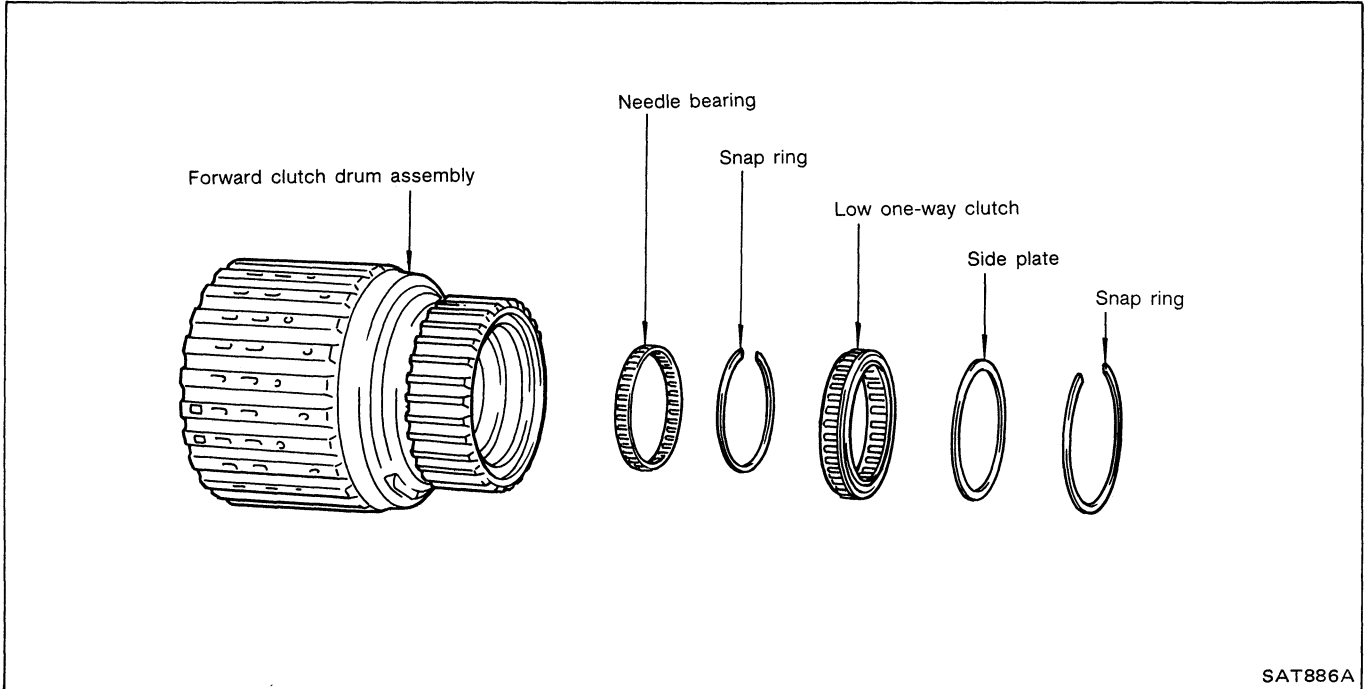

SAT886A

DISASSEMBLY

1. Remove snap ring from forward clutch drum.

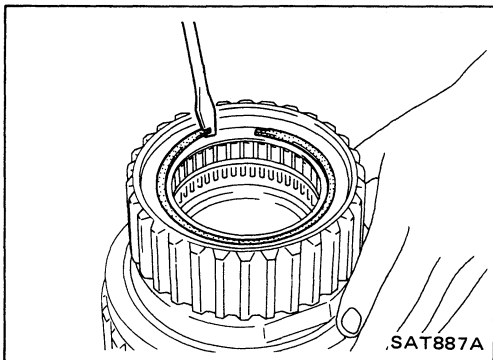

2. Remove side plate from forward clutch drum.

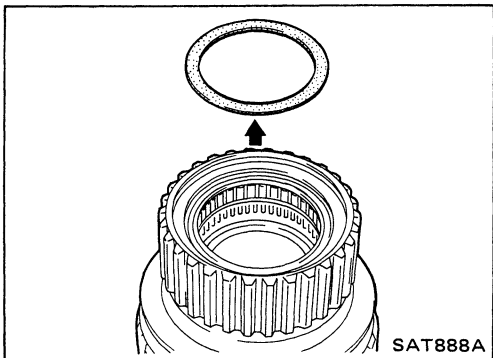

3. Remove low one-way clutch from forward clutch drum.

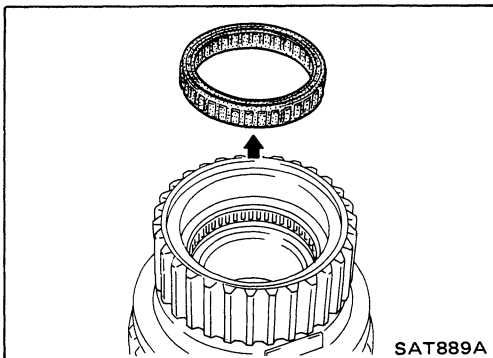

Forward Clutch Drum Assembly (Cont'd)

4. Remove snap ring from forward clutch drum.

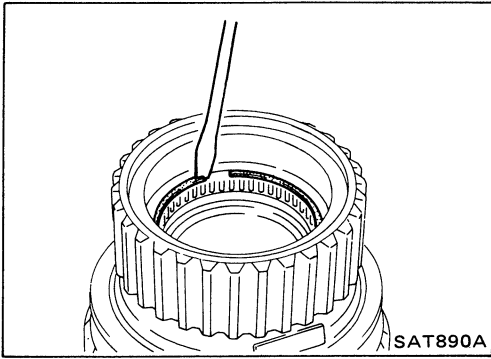

5. Remove needle bearing from forward clutch drum.

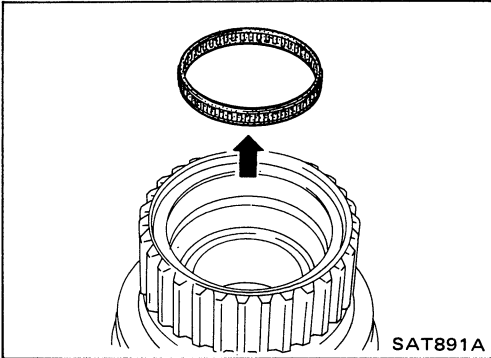

INSPECTION

Forward clutch drum

- Check spline portion for wear or damage.
- Check frictional surfaces of low one-way clutch and needle bearing for wear or damage.

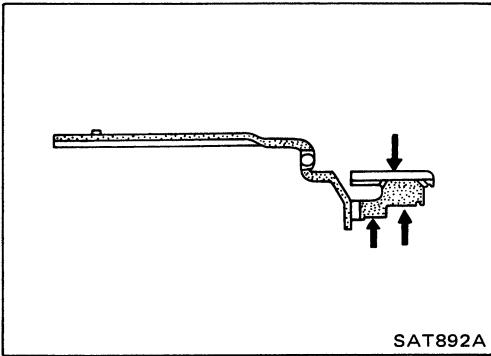

Needle bearing and low one-way clutch

- Check frictional surface for wear or damage.

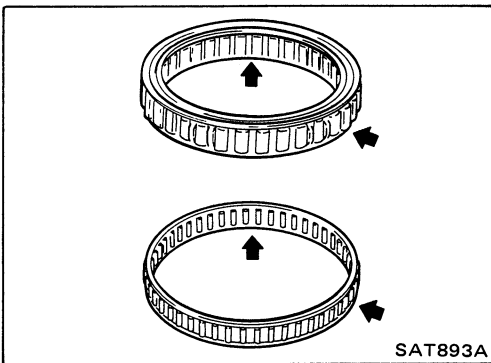

ASSEMBLY

1. Install needle bearing in forward clutch drum.

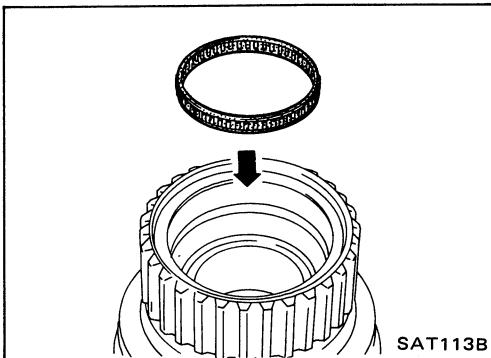

Forward Clutch Drum Assembly (Cont'd)

2. Install snap ring onto forward clutch drum.

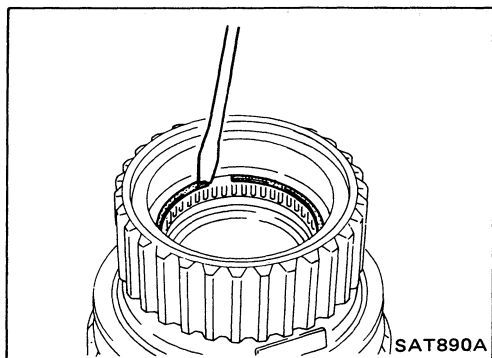

3. Install low one-way clutch onto forward clutch drum by pushing the roller in evenly.

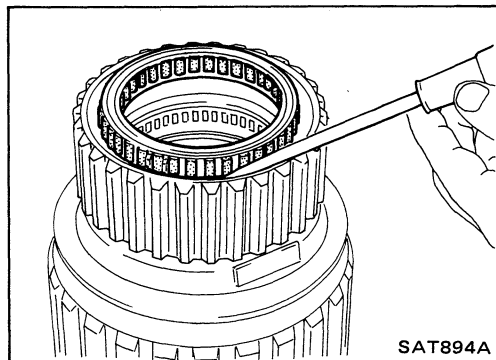

● Install low one-way clutch with flange facing rearward.

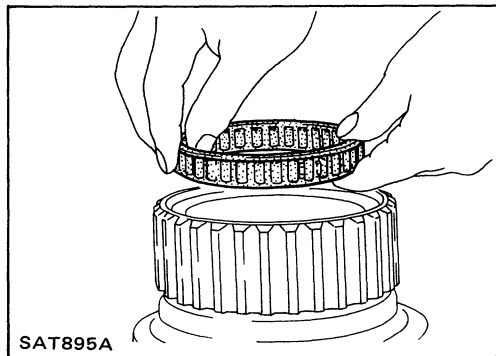

4. Install side plate onto forward clutch drum.
5. Install snap ring onto forward clutch drum.

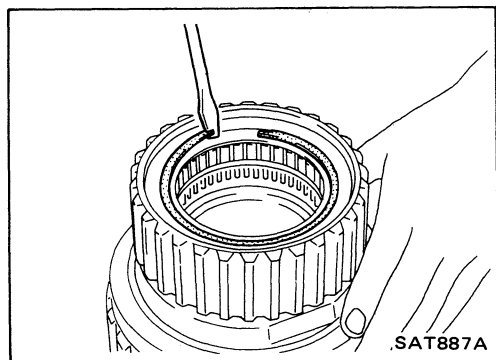

Rear Internal Gear and Forward Clutch Hub

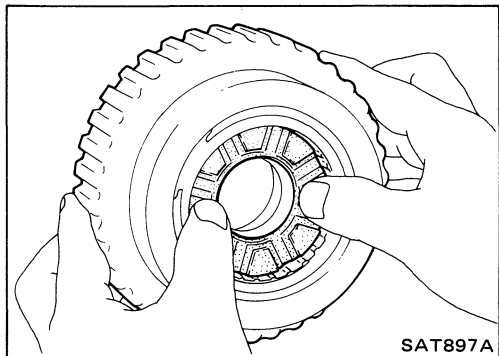
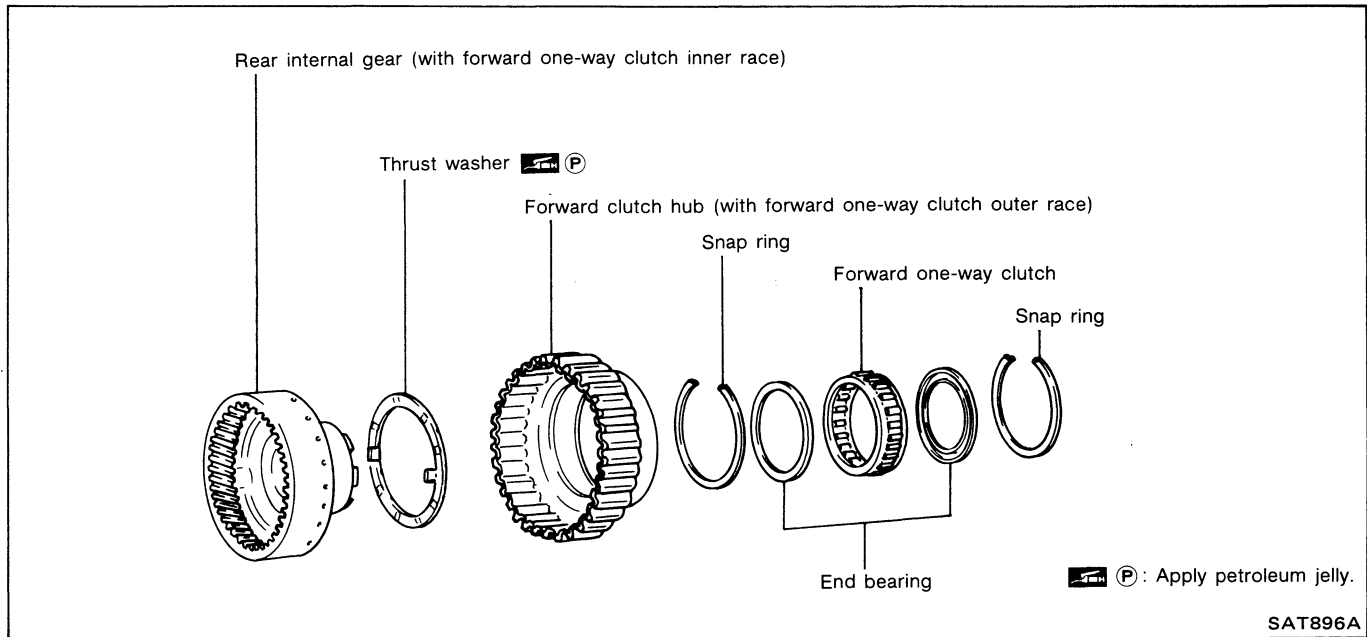

DISASSEMBLY

1. Remove rear internal gear by pushing forward clutch hub forward.

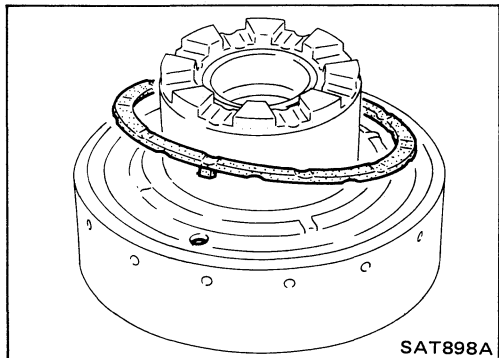

2. Remove thrust washer from rear internal gear.

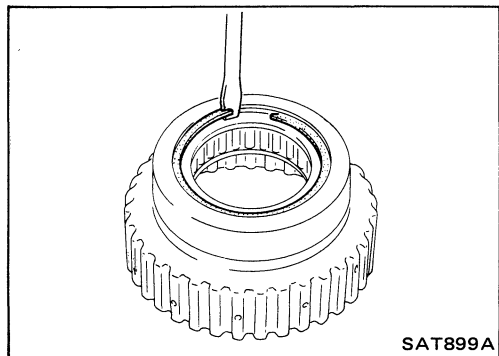

3. Remove snap ring from forward clutch hub.

Rear Internal Gear and Forward Clutch Hub (Cont'd)

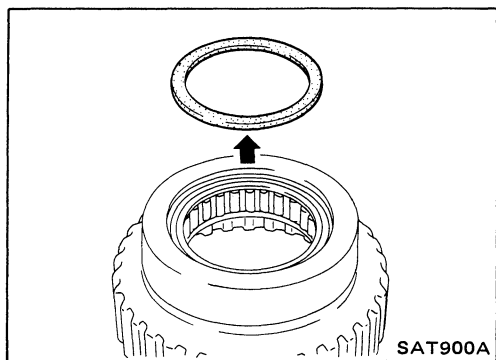

4. Remove end bearing.

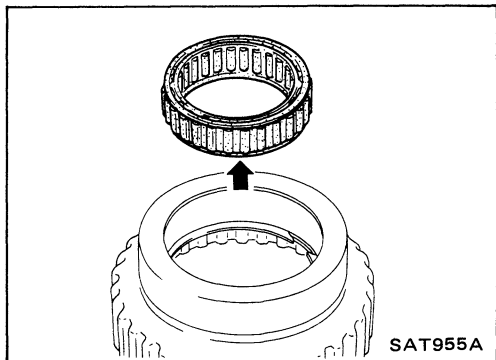

5. Remove forward one-way clutch and end bearing as a unit from forward clutch hub.

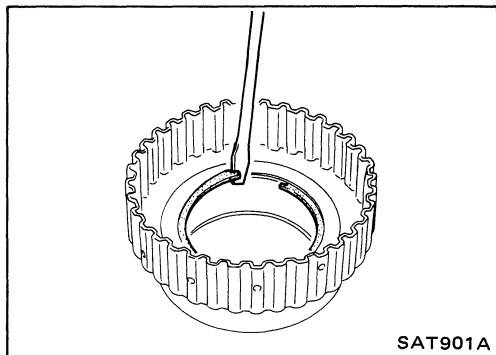

6. Remove snap ring from forward clutch hub.

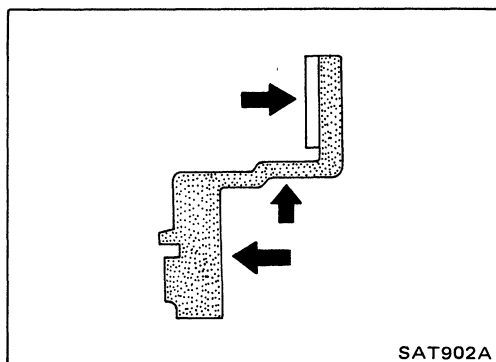

INSPECTION

Rear internal gear and forward clutch hub

- Check gear for excessive wear, chips or cracks.
- Check frictional surfaces of forward one-way clutch and thrust washer for wear or damage.
- Check spline for wear or damage.

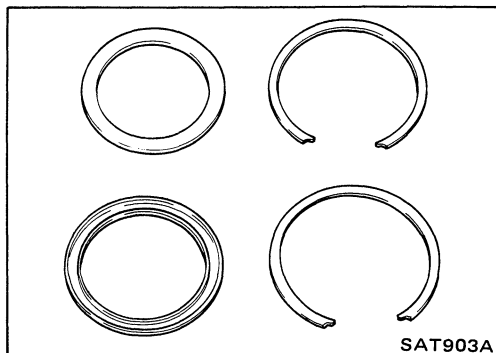

Snap ring and end bearing

- Check for deformation or damage.

Rear Internal Gear and Forward Clutch Hub
(Cont'd)

ASSEMBLY

1. Install snap ring onto forward clutch hub.
2. Install end bearing.

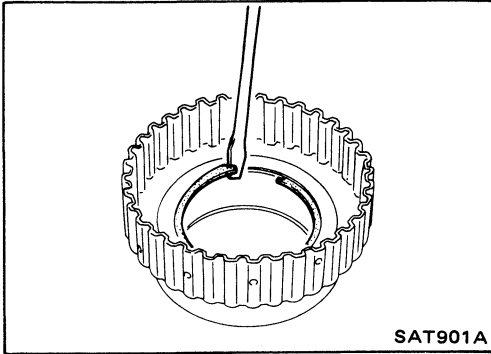

3. Install forward one-way clutch onto clutch hub.
 - Install forward one-way clutch with flange facing rearward.
4. Install end bearing.
5. Install snap ring onto forward clutch hub.

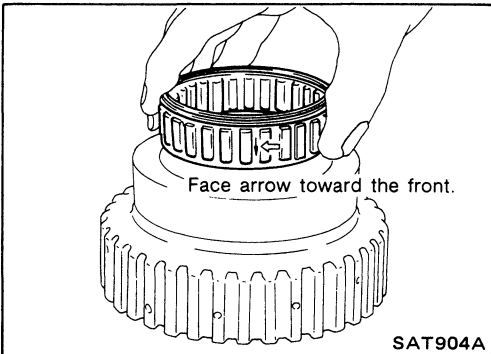

6. Install thrust washer onto rear internal gear.
 - Apply petroleum jelly to thrust washer.
 - Securely insert pawls of thrust washer into holes in rear internal gear.

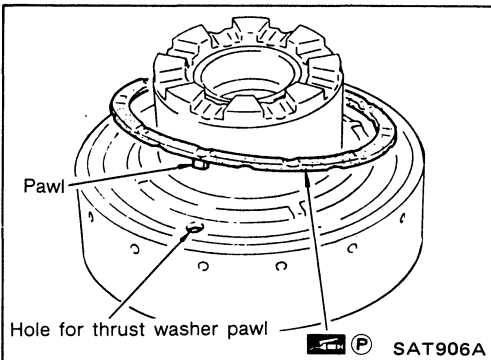

7. Position forward clutch hub in rear internal gear.

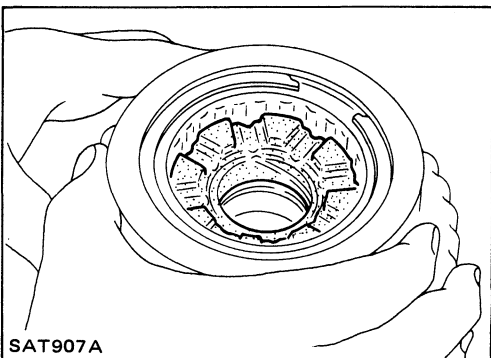

8. After installing, check to assure that forward clutch hub rotates clockwise.

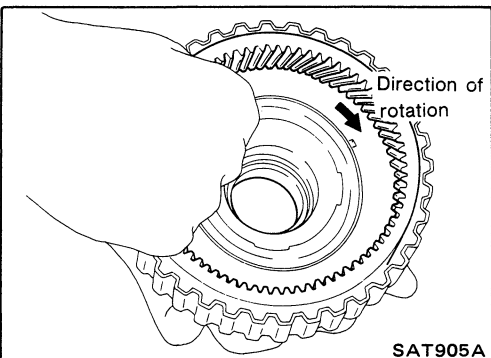

Band Servo Piston Assembly

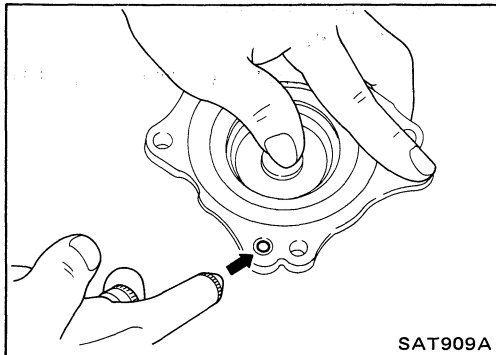
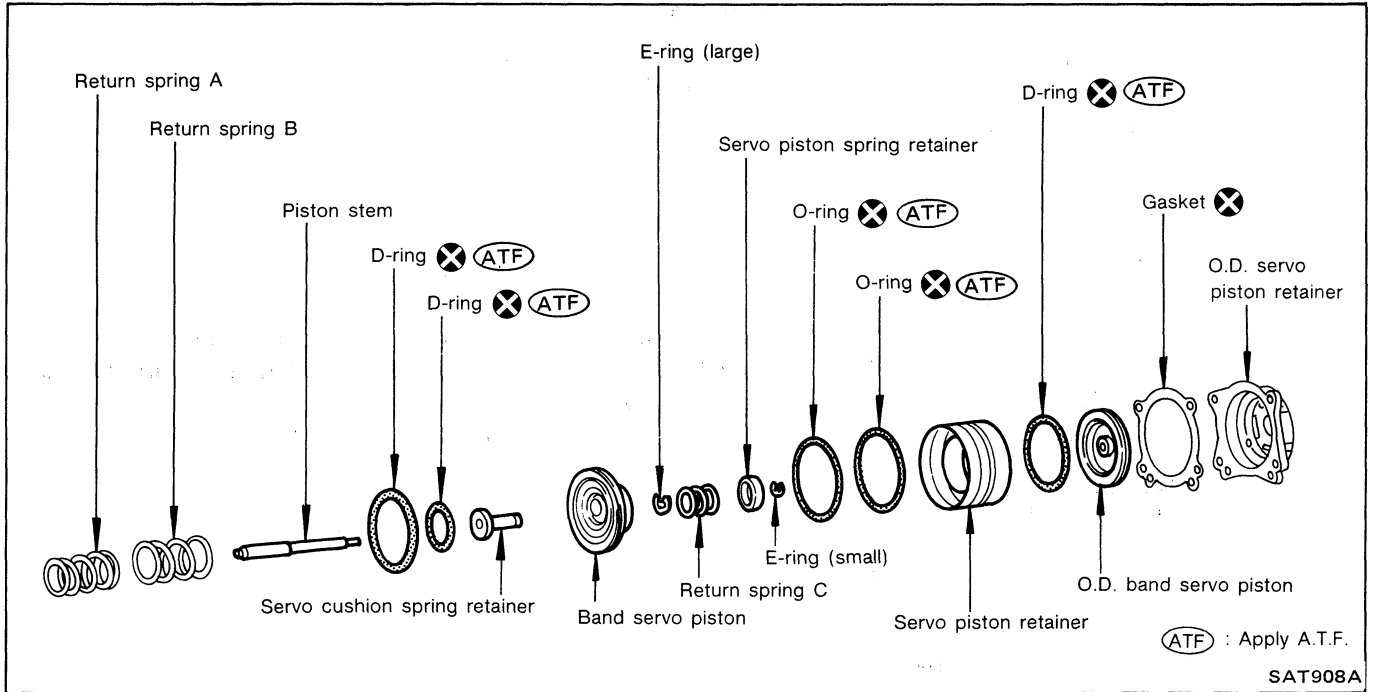

DISASSEMBLY

1. Block one oil hole in O.D. servo piston retainer and the center hole in O.D. band servo piston.
2. Apply compressed air to the other oil hole in piston retainer to remove O.D. band servo piston from retainer.
3. Remove D-ring from O.D. band servo piston.

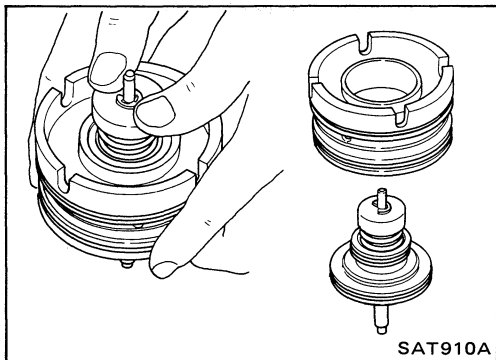

4. Remove band servo piston assembly from servo piston retainer by pushing it forward.

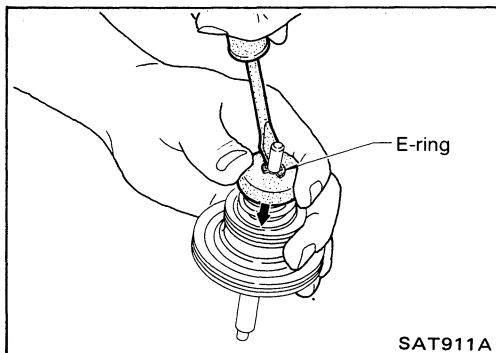

5. Place piston stem end on a wooden block. While pushing servo piston spring retainer down, remove E-ring.

Band Servo Piston Assembly (Cont'd)

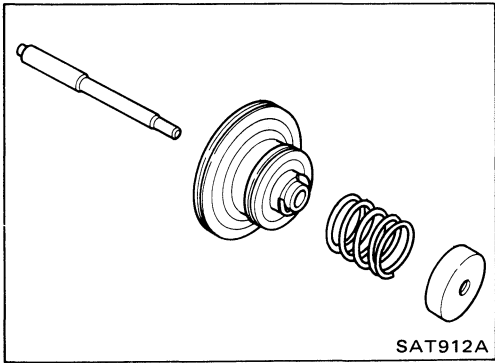

6. Remove servo piston spring retainer, return spring C and piston stem from band servo piston.

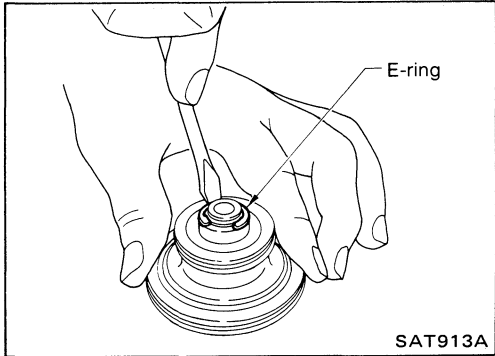

7. Remove E-ring from band servo piston.

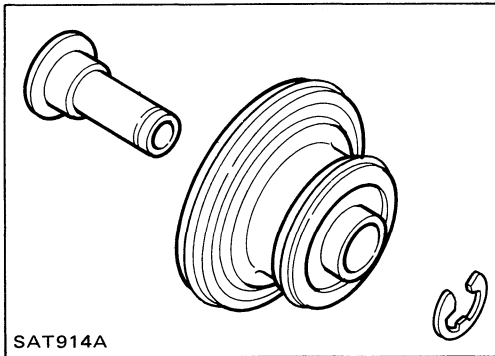

8. Remove servo cushion spring retainer from band servo piston.
 9. Remove D-rings from band servo piston.
 10. Remove O-rings from servo piston retainer.

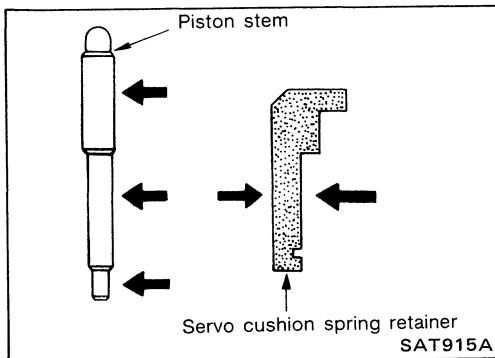

INSPECTION

Pistons, retainers and piston stem

- Check frictional surfaces for abnormal wear or damage.

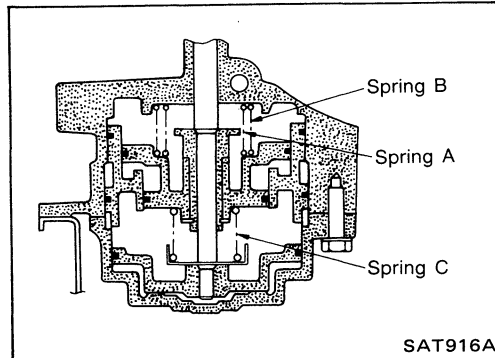

Return springs

- Check for deformation or damage. Measure free length and outer diameter.

Inspection standard

Unit: mm (in)

Parts	Free length	Outer diameter
Spring A	45.6 (1.795)	34.3 (1.350)
Spring B	53.8 (2.118)	40.3 (1.587)
Spring C	29.0 (1.142)	27.6 (1.087)

**Band Servo Piston Assembly (Cont'd)
ASSEMBLY**

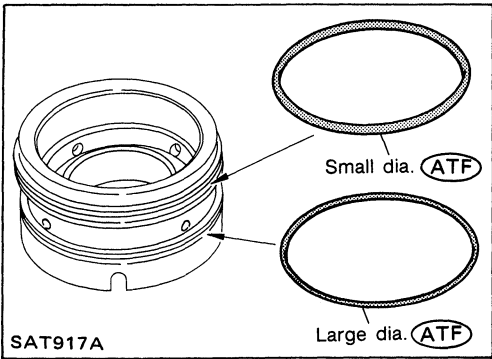

1. Install O-rings onto servo piston retainer.
 - **Apply A.T.F. to O-rings.**
 - **Pay attention to position of each O-ring.**

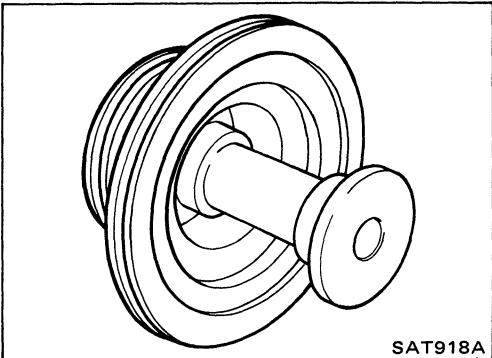

2. Install servo cushion spring retainer onto band servo piston.

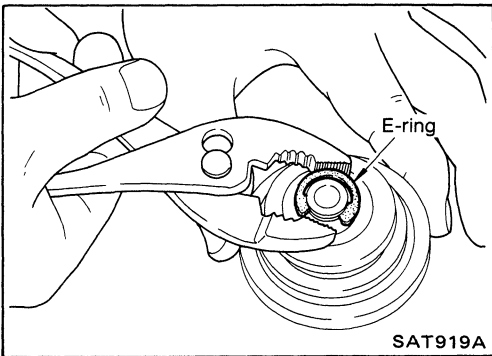

3. Install E-ring onto servo cushion spring retainer.

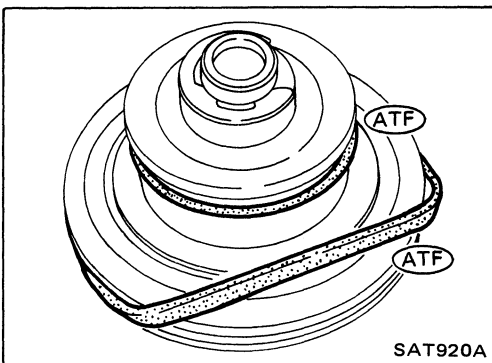

4. Install D-rings onto band servo piston.
 - **Apply A.T.F. to D-rings.**

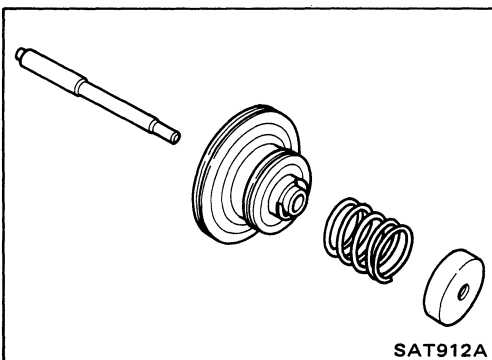

5. Install servo piston spring retainer, return spring C and piston stem onto band servo piston.

Band Servo Piston Assembly (Cont'd)

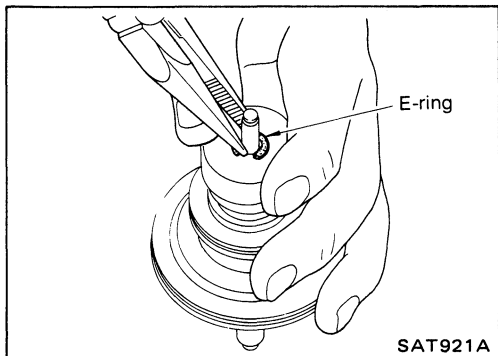

6. Place piston stem end on a wooden block. While pushing servo piston spring retainer down, install E-ring.

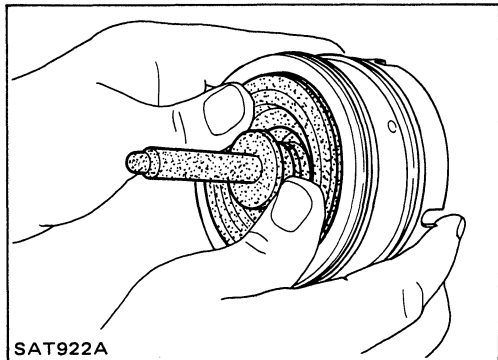

7. Install band servo piston assembly onto servo piston retainer by pushing it inward.

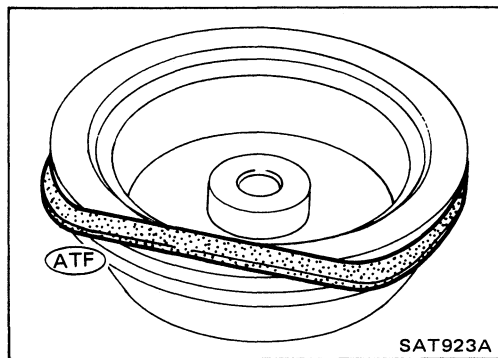

8. Install D-ring on O.D. band servo piston.

● **Apply A.T.F. to D-ring.**

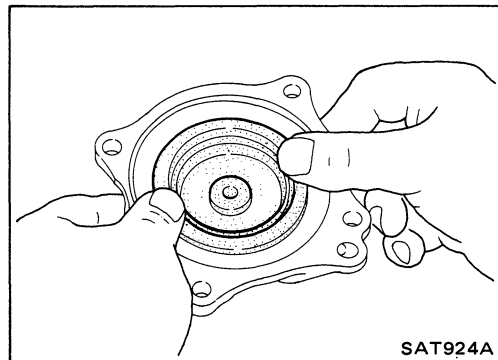

9. Install O.D. band servo piston onto servo piston retainer by pushing it inward.

Parking Pawl Components

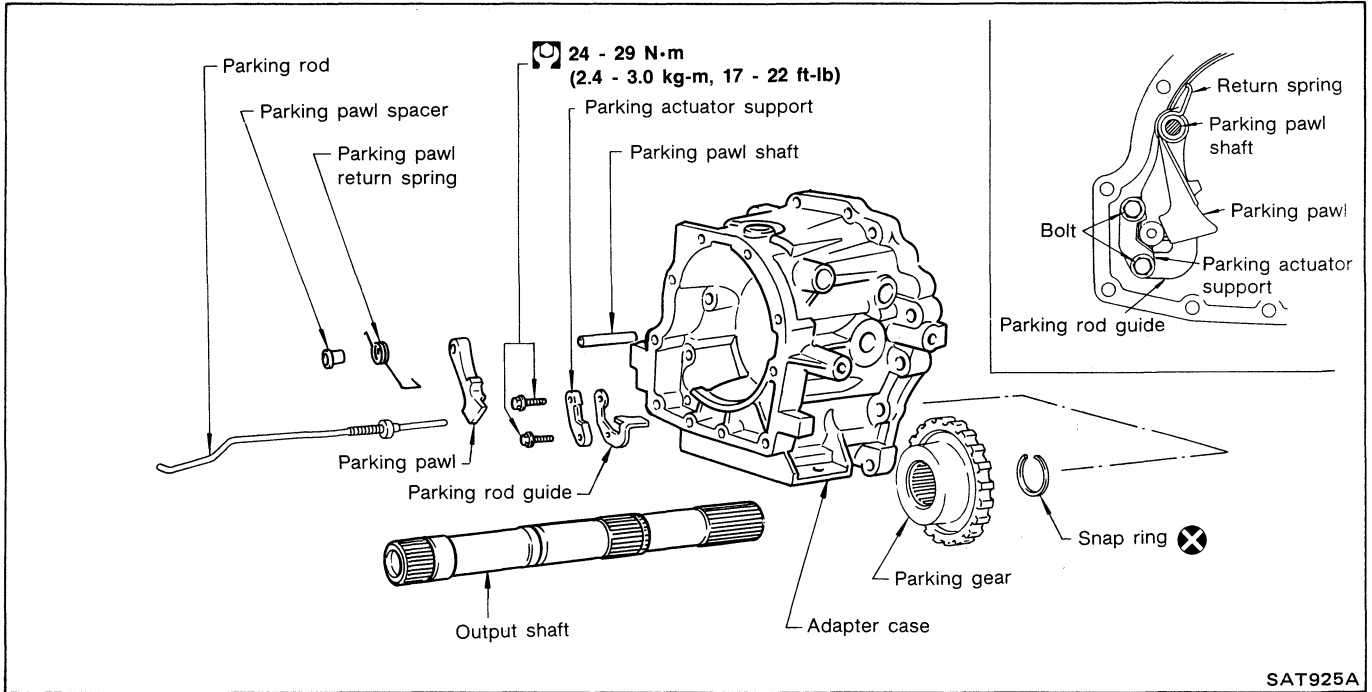

DISASSEMBLY

1. Slide return spring to the front of adapter case flange.

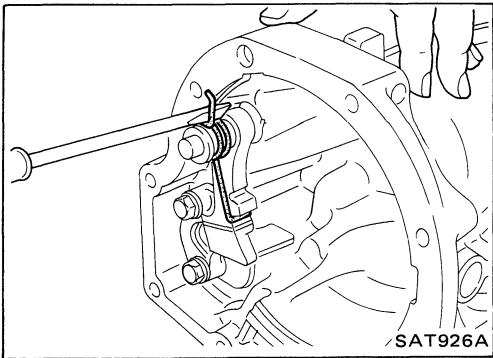

2. Remove return spring, pawl spacer and parking pawl from adapter case.
3. Remove parking pawl shaft from adapter case.

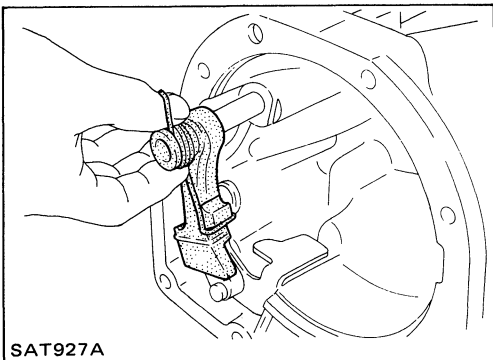

4. Remove parking actuator support and rod guide from adapter case.

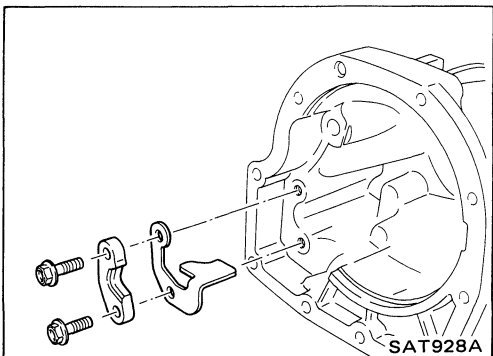

Parking Pawl Components (Cont'd)**INSPECTION****Parking pawl and parking actuator support**

- Check contact surface of parking rod for wear.

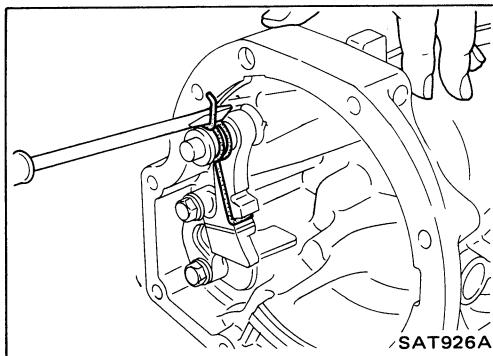
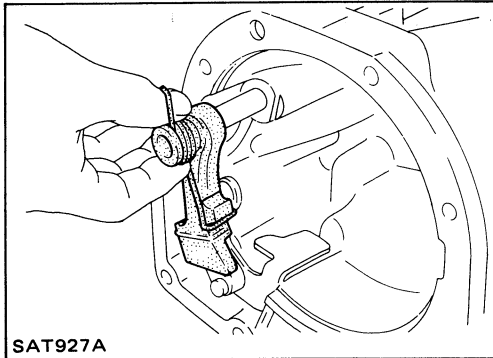
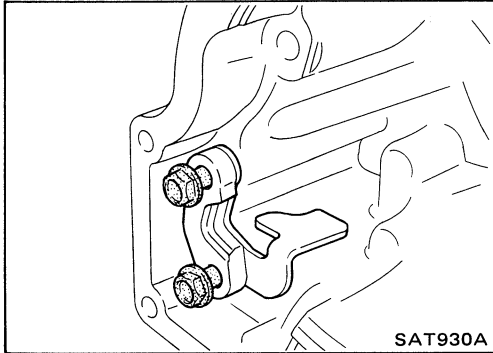
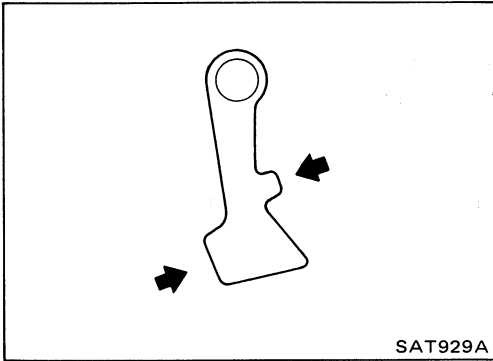
**ASSEMBLY**

1. Install rod guide and parking actuator support onto adapter case.
2. Insert parking pawl shaft into adapter case.
3. Install return spring, pawl spacer and parking pawl onto parking pawl shaft.
4. Bend return spring upward and install it onto adapter case.

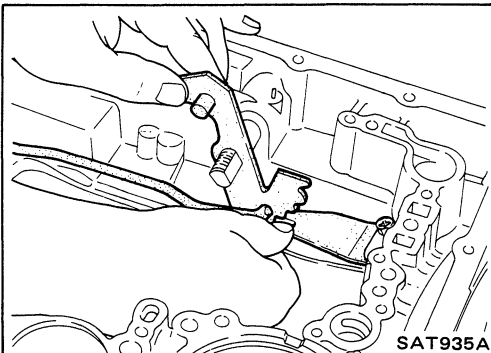
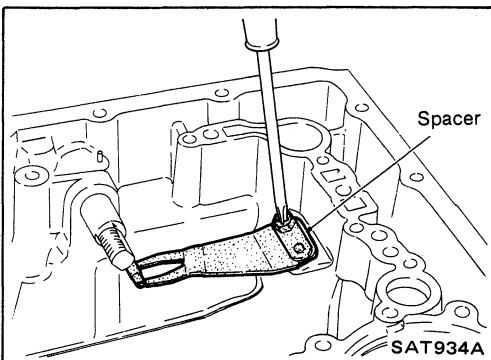
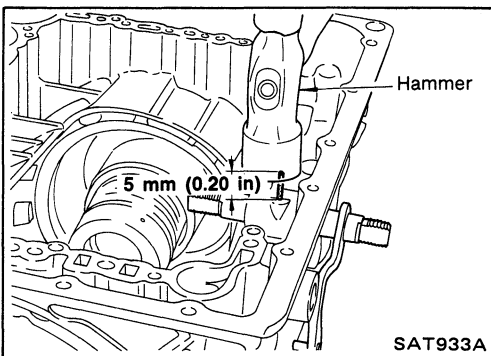
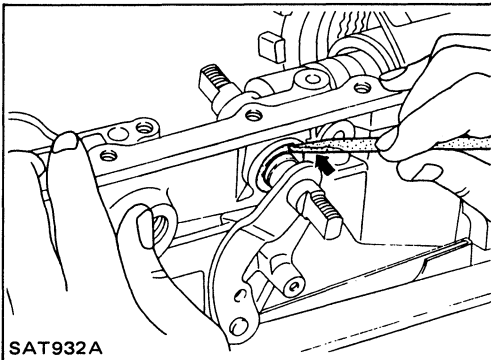
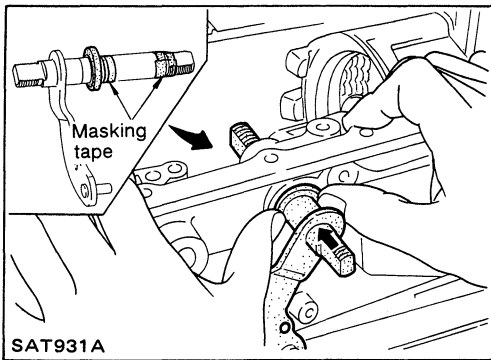

Assembly

1. Install manual shaft components.
 - a. Install oil seal onto manual shaft.
 - **Apply A.T.F. to oil seal.**
 - **Wrap threads of manual shaft with masking tape.**
 - b. Insert manual shaft and oil seal as a unit into transmission case.
 - c. Remove masking tape.
- d. Push oil seal evenly and install it onto transmission case.
- e. Align groove in shaft with drive pin hole, then drive pin into position as shown in figure at left.
- f. Install detent spring and spacer.
- g. While pushing detent spring down, install manual plate onto manual shaft.

Assembly (Cont'd)

h. Install lock nuts onto manual shaft.

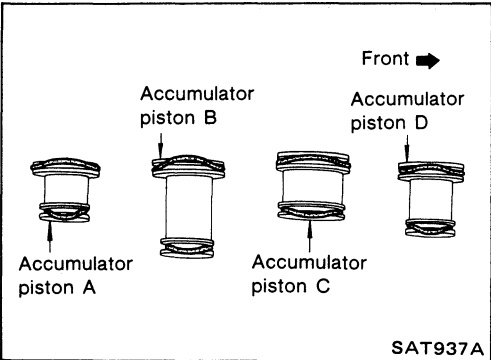
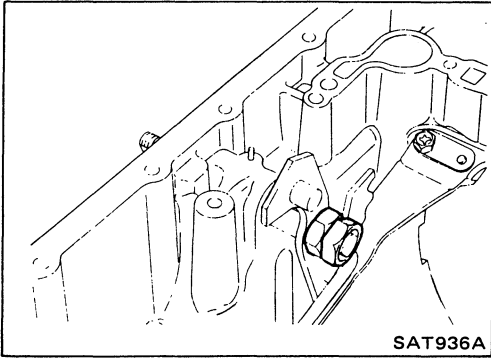

2. Install accumulator piston.
 a. Install O-rings onto accumulator piston.
 ● **Apply A.T.F. to O-rings.**

Accumulator piston O-rings

Unit: mm (in)

Accumulator	A	B	C	D
Small diameter end	29 (1.14)	32 (1.26)	45 (1.77)	29 (1.14)
Large diameter end	45 (1.77)	50 (1.97)	50 (1.97)	45 (1.77)

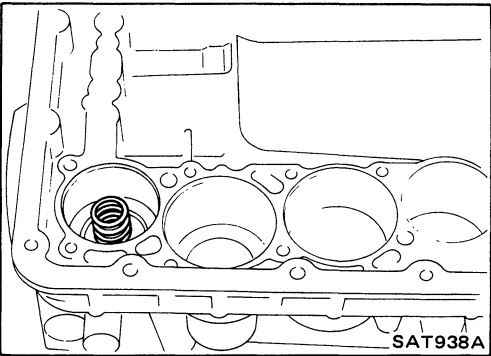

b. Install return spring for accumulator A onto transmission case.

Free length of return spring

Unit: mm (in)

Accumulator	A
Free length	43 (1.69)

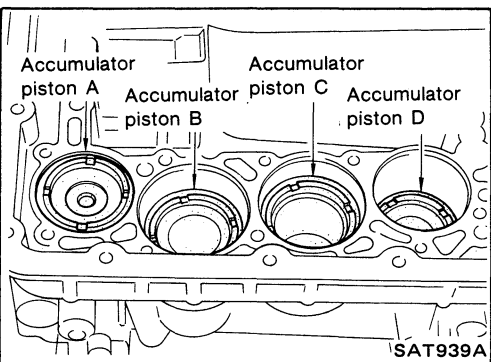

c. Install accumulator pistons A, B, C and D.
 ● **Apply A.T.F. to transmission case.**

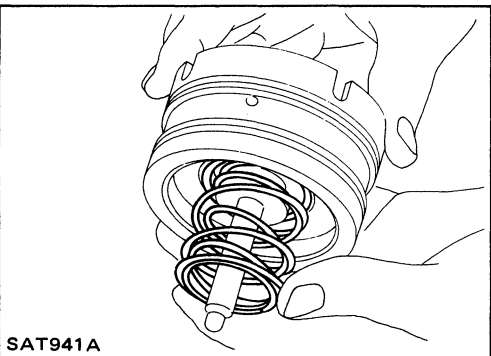

3. Install band servo piston.
 a. Install return springs onto servo piston.

Assembly (Cont'd)

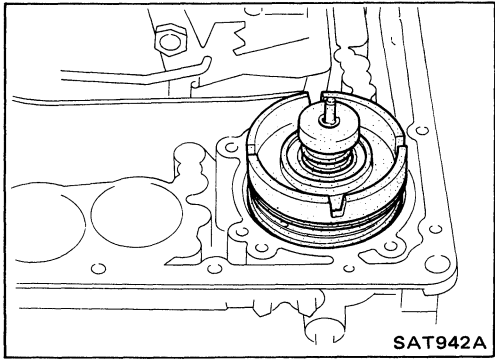

- b. Install band servo piston onto transmission case.
- Apply A.T.F. to O-ring of band servo piston and transmission case.
- c. Install gasket for band servo onto transmission case.

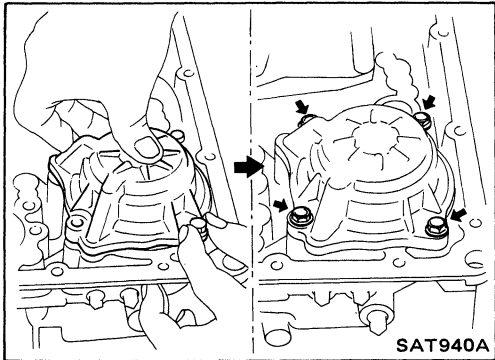

- d. Install band servo retainer onto transmission case.

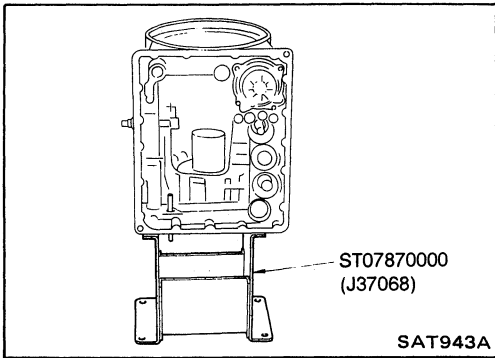

- 4. Install rear side clutch and gear components.
- a. Place transmission case in vertical position.

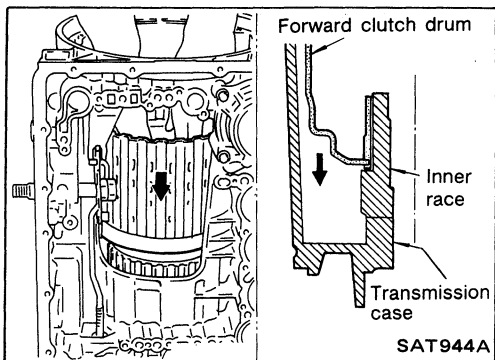

- b. Slightly lift forward clutch drum assembly and slowly rotate it clockwise until its hub passes fully over the clutch inner race inside transmission case.

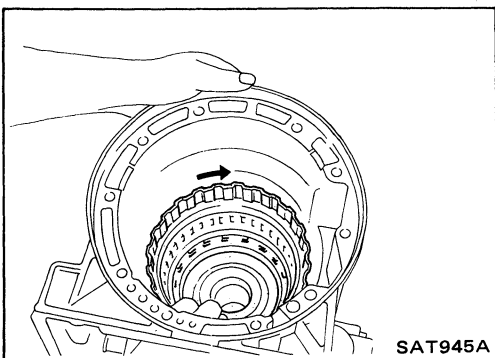

- c. Check to be sure that rotation direction of forward clutch assembly is correct.

Assembly (Cont'd)

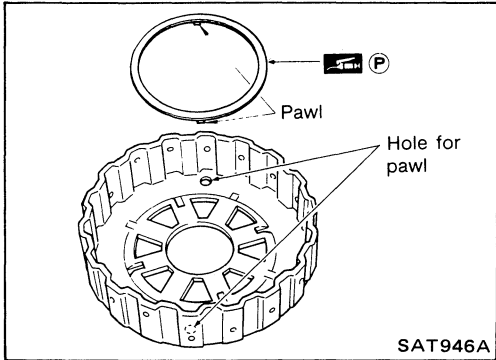

- d. Install thrust washer onto front of overrun clutch hub.
- Apply petroleum jelly to the thrust washer.
 - Insert pawls of thrust washer securely into holes in overrun clutch hub.

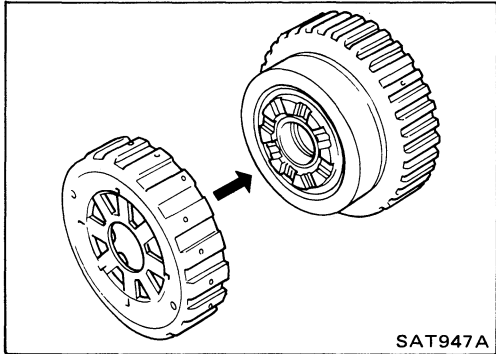

- e. Install overrun clutch hub onto rear internal gear assembly.

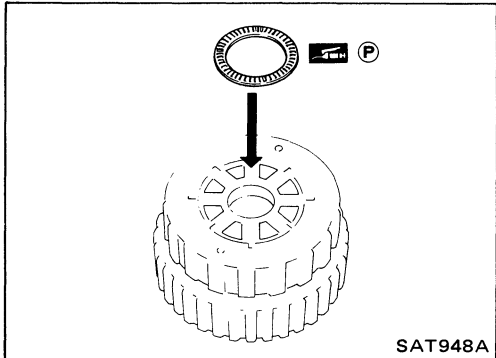

- f. Install needle bearing onto rear of overrun clutch hub.
- Apply petroleum jelly to needle bearing.

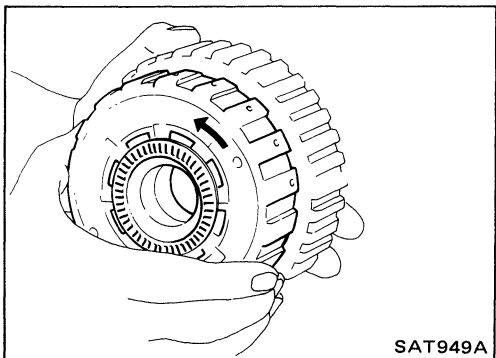

- g. Check that overrun clutch hub rotates as shown while holding forward clutch hub.

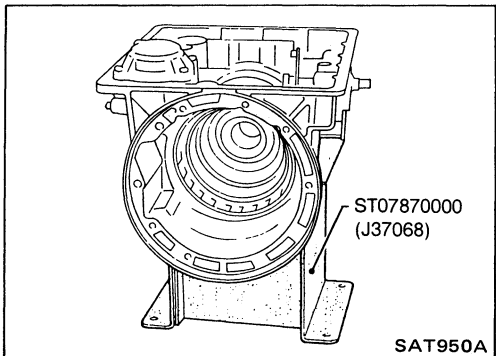

- h. Place transmission case into horizontal position.

Assembly (Cont'd)

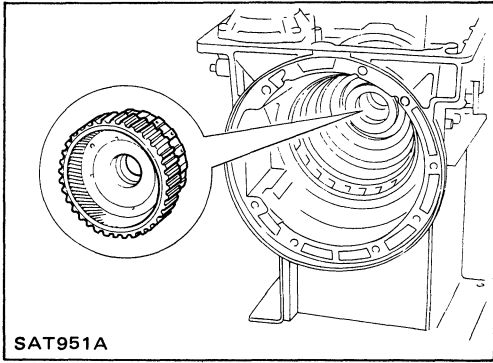

- i. Install rear internal gear, forward clutch hub and overrun clutch hub as a unit onto transmission case.

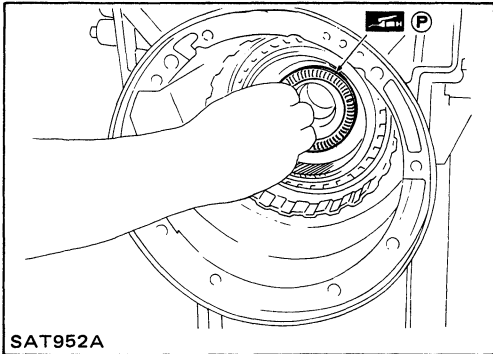

- j. Install needle bearing onto rear internal gear.
 - **Apply petroleum jelly to needle bearing.**

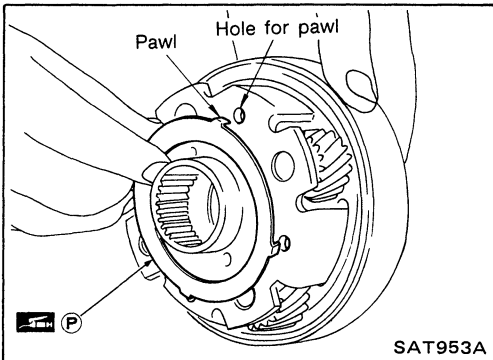

- k. Install bearing race onto rear of front internal gear.
 - **Apply petroleum jelly to bearing race.**
 - **Securely engage pawls of bearing race with holes in front internal gear.**

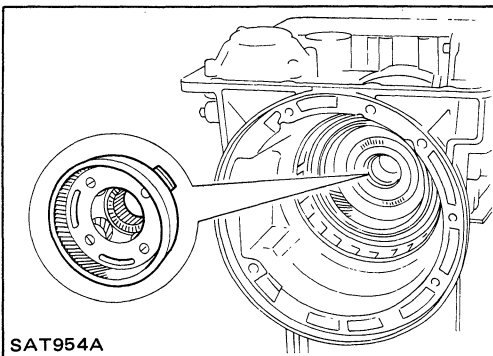

- l. Install front internal gear on transmission case.

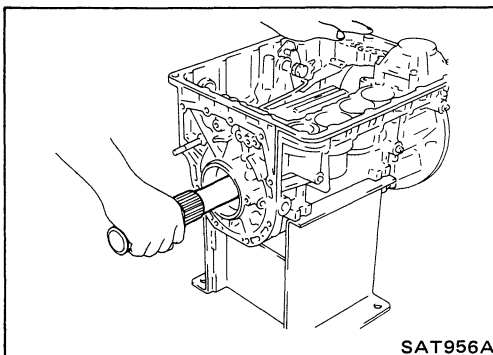

- 5. Install output shaft and parking gear.
 - a. Insert output shaft from rear of transmission case while slightly lifting front internal gear.
 - **Do not force output shaft against front of transmission case.**

Assembly (Cont'd)

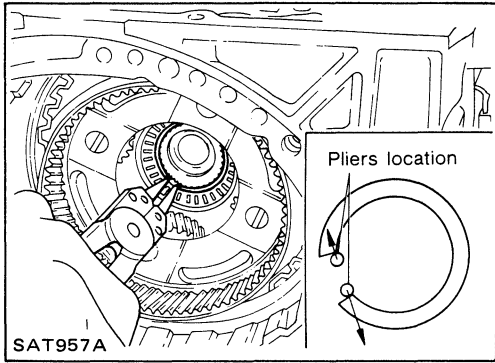

- b. Carefully push output shaft against front of transmission case. Install snap ring on front of output shaft.
- **Check to be sure output shaft cannot be removed in rear direction.**

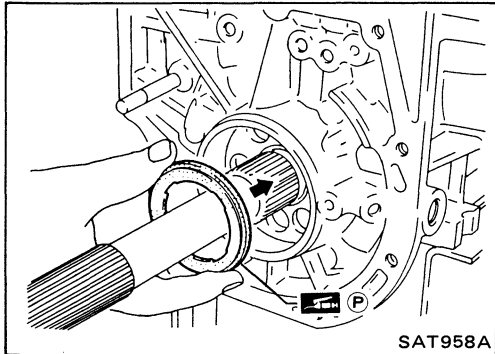

- c. Install needle bearing on transmission case.
- **Pay attention to its direction — Black side goes to front.**
- **Apply petroleum jelly to needle bearing.**

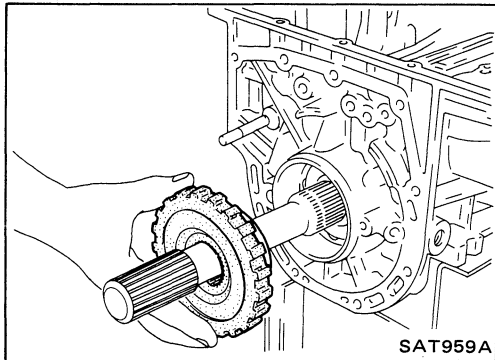

- d. Install parking gear on transmission case.

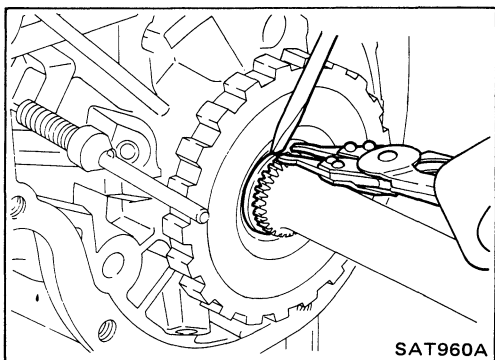

- e. Install snap ring on rear of output shaft.
- **Check to be sure output shaft cannot be removed in forward direction.**

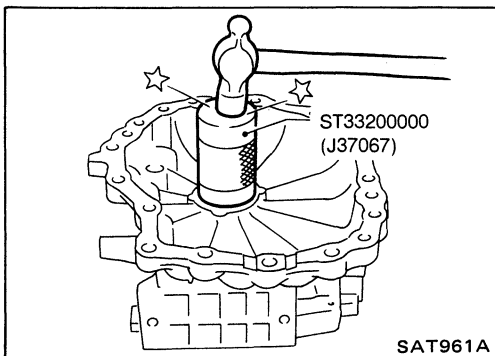

- 6. Install adapter case.
- a. Install oil seal on adapter case.
- **Apply A.T.F. to oil seal.**

Assembly (Cont'd)

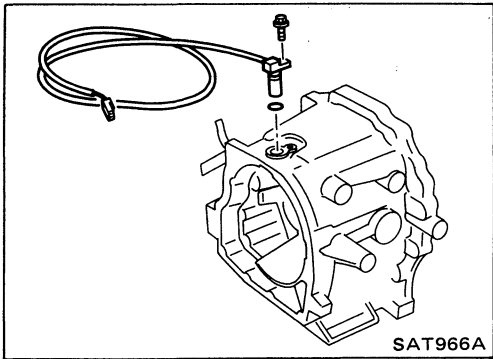

- b. Install O-ring on revolution sensor.
 - **Apply A.T.F. to O-ring.**
- c. Install revolution sensor on adapter case.

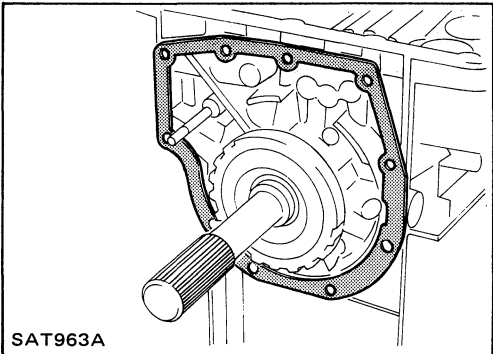

- d. Install adapter case gasket on transmission case.

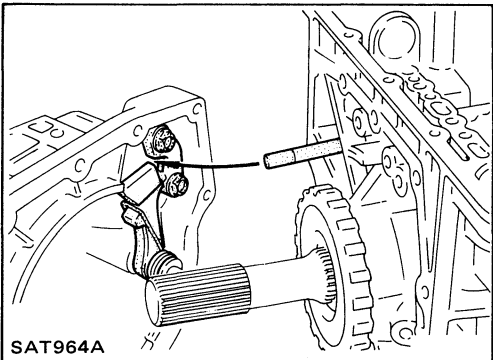

- e. Install parking rod on transmission case.

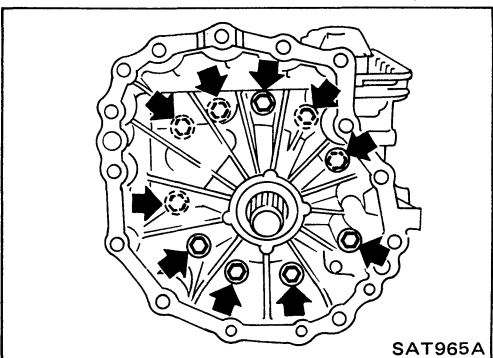

- f. Install adapter case on transmission case.

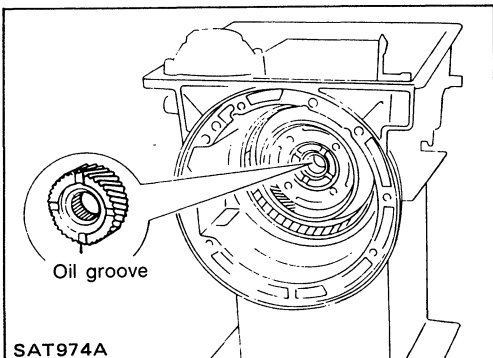

- 7. Install front side clutch and gear components.
 - a. Install rear sun gear on transmission case.
 - **Pay attention to its direction.**

Assembly (Cont'd)

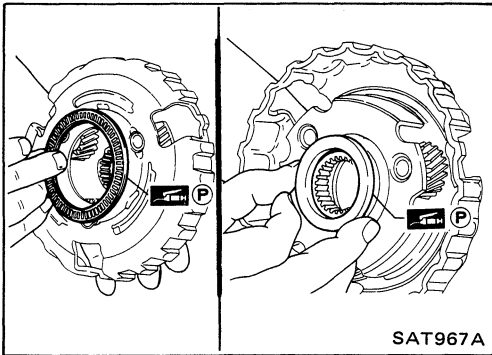

SAT967A

- b. Install needle bearing on front of front planetary carrier.
- **Apply petroleum jelly to needle bearing.**
- c. Install needle bearing on rear of front planetary carrier.
- **Apply petroleum jelly to bearing.**
- **Pay attention to its direction — Black side goes to front.**

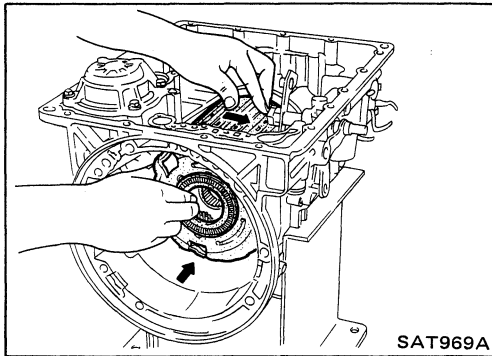

SAT969A

- d. While rotating forward clutch drum clockwise, install front planetary carrier on forward clutch drum.

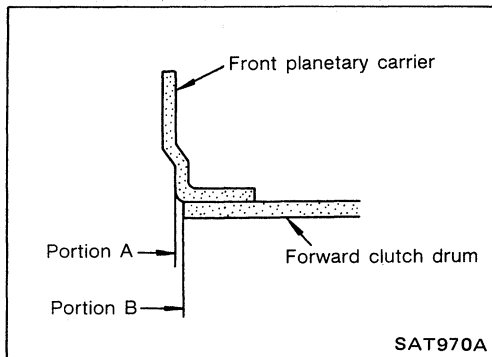

SAT970A

- **Check that portion A of front planetary carrier protrudes approximately 2 mm (0.08 in) beyond portion B of forward clutch assembly.**

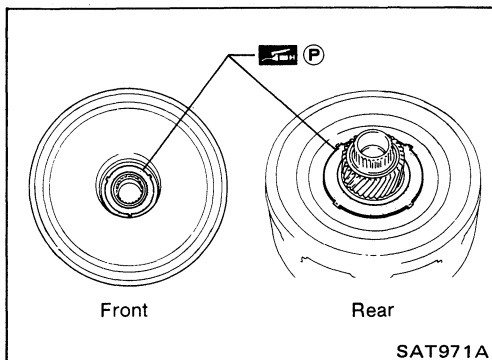

SAT971A

- e. Install bearing races on front and rear of clutch pack.
- **Apply petroleum jelly to bearing races.**
- **Securely engage pawls of bearing races with holes in clutch pack.**

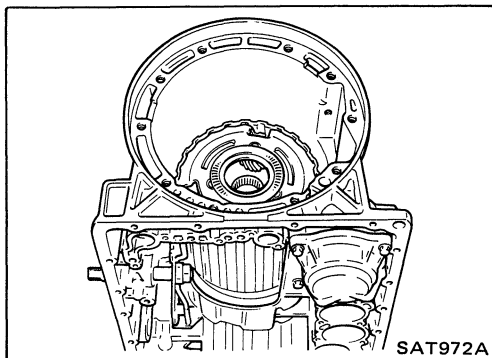

SAT972A

- f. Place transmission case in vertical position.

Assembly (Cont'd)

g. Install clutch pack into transmission case.

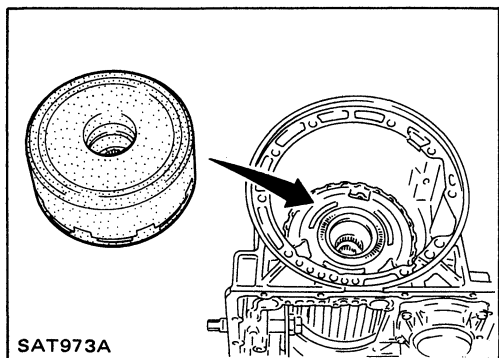

Adjustment

When any parts listed in the following table are replaced, total end play or reverse clutch end play must be adjusted.

Part name	Item	Total end play	Reverse clutch end play
Transmission case		•	•
Low one-way clutch inner race		•	•
Overrun clutch hub		•	•
Rear internal gear		•	•
Rear planetary carrier		•	•
Rear sun gear		•	•
Front planetary carrier		•	•
Front sun gear		•	•
High clutch hub		•	•
High clutch drum		•	•
Oil pump cover		•	•
Reverse clutch drum		—	•

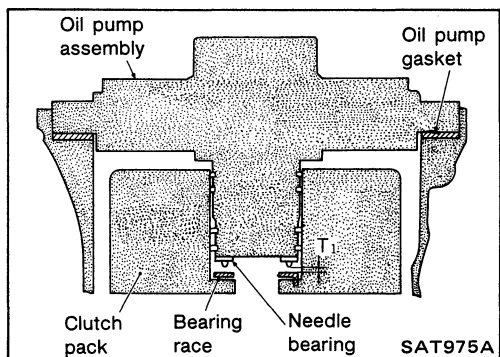

1. Adjust total end play.

Total end play "T₁":

0.25 - 0.55 mm (0.0098 - 0.0217 in)

Adjustment (Cont'd)

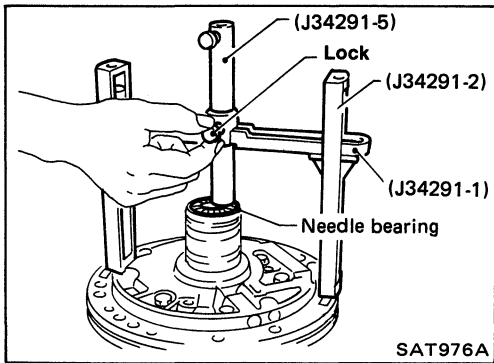

- a. With needle bearing installed, place J34291-1 (bridge), J34291-2 (legs) and the J34291-5 (gauging cylinder) onto oil pump. The long ends of legs should be placed firmly on machined surface of oil pump assembly and gauging cylinder should rest on top of the needle bearing. Lock gauging cylinder in place with set screw.

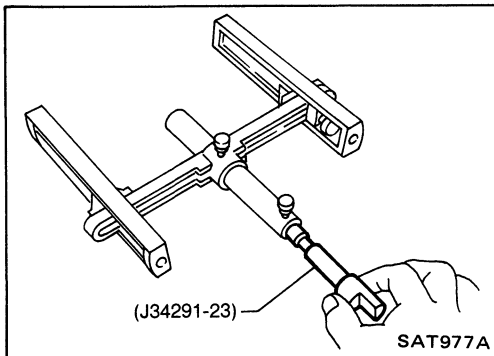

- b. Install J34291-23 (gauging plunger) into gauging cylinder.

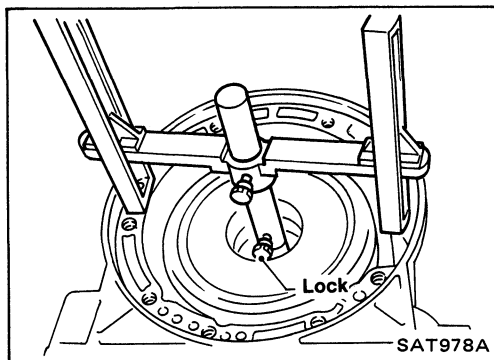

- c. With original bearing race installed inside reverse clutch drum, place shim selecting gauge with its legs on machined surface of transmission case (no gasket) and allow gauging plunger to rest on bearing race. Lock gauging plunger in place with set screw.

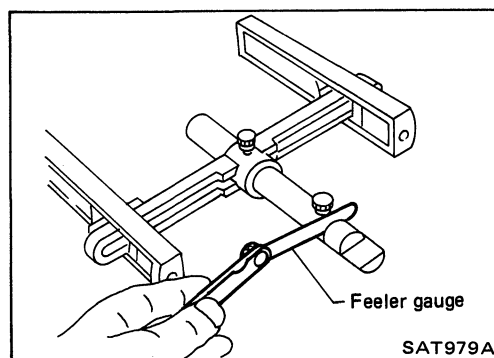

- d. Remove Tool and use feeler gauge to measure gap between gauging cylinder and gauging plunger. This measurement should give exact total end play.

Total end play "T₁":

0.25 - 0.55 mm (0.0098 - 0.0217 in)

- If end play is out of specification, decrease or increase thickness of oil pump cover bearing race as necessary.

Available oil pump cover bearing race:

Refer to S.D.S.

2. Adjust reverse clutch drum end play.

Reverse clutch drum end play "T₂":

0.55 - 0.90 mm (0.0217 - 0.0354 in)

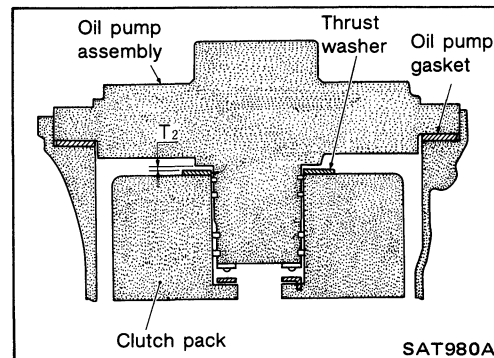

Adjustment (Cont'd)

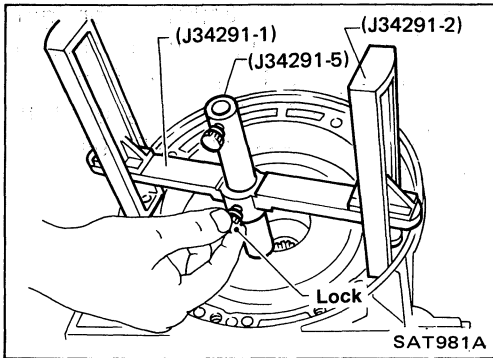

- a. Place J34291-1 (bridge), J34291-2 (legs) and J34291-5 (gauging cylinder) on machined surface of transmission case (no gasket) and allow gauging cylinder to rest on front thrust surface of reverse clutch drum. Lock cylinder in place with set screw.

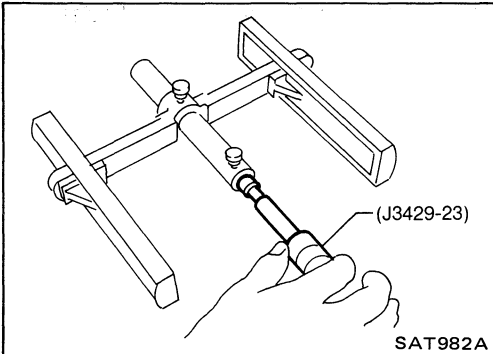

- b. Install J3429-23 (gauging plunger) into gauging cylinder.

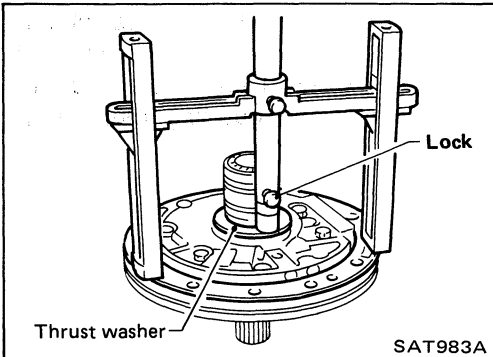

- c. With original thrust washer installed on oil pump, place shim setting gauge legs onto machined surface of oil pump assembly and allow gauging plunger to rest on thrust washer. Lock plunger in place with set screw.

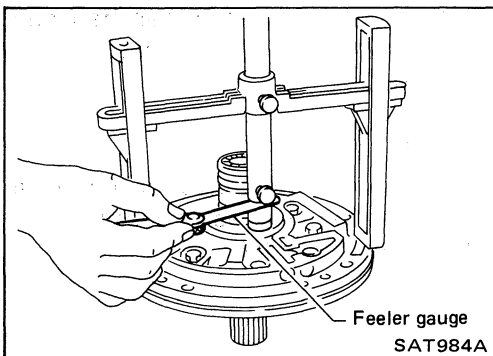

- d. Use feeler gauge to measure gap between gauging plunger and gauging cylinder. This measurement should give you exact reverse clutch drum end play.

Reverse clutch drum end play "T₂":

0.55 - 0.90 mm (0.0217 - 0.0354 in)

- If end play is out of specification, decrease or increase thickness of oil pump thrust washer as necessary.

Available oil pump thrust washer:

Refer to S.D.S.

Assembly

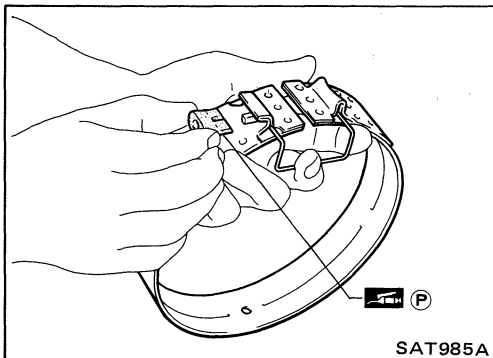

1. Place transmission case into horizontal position.
2. Install brake band and band strut.
 - a. Install band strut on brake band.
 - **Apply petroleum jelly to band strut.**

Assembly (Cont'd)

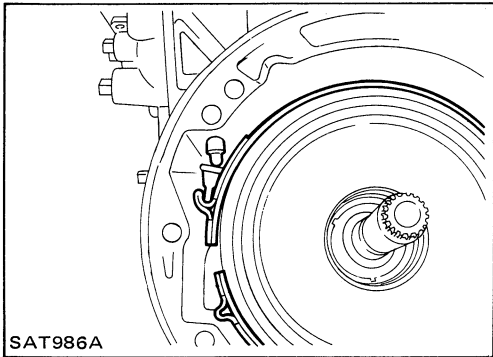

- b. Place brake band on periphery of reverse clutch drum, and insert band strut into end of band servo piston stem.

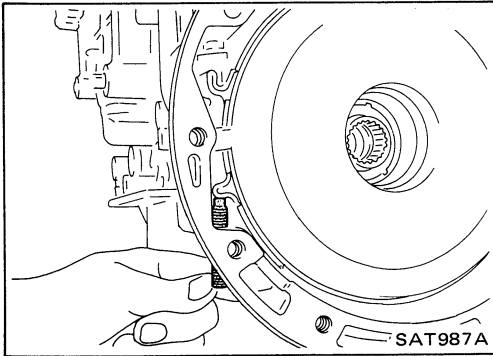

- c. Install anchor end bolt on transmission case. Then, tighten anchor end bolt just enough so that reverse clutch drum (clutch pack) will not tilt forward.

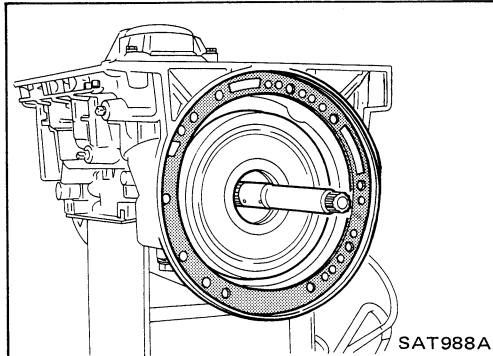

- 3. Install input shaft on transmission case.
 - Pay attention to its direction — O-ring groove side is front.
- 4. Install gasket on transmission case.

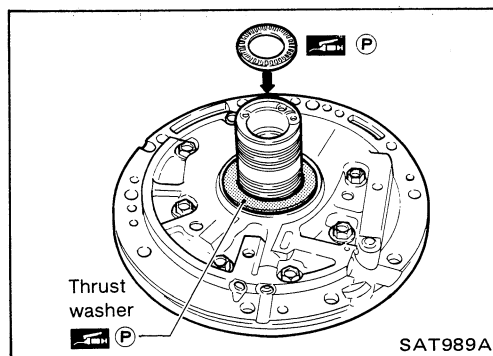

- 5. Install oil pump assembly.
 - a. Install needle bearing on oil pump assembly.
 - Apply petroleum jelly to the needle bearing.
 - b. Install selected thrust washer on oil pump assembly.
 - Apply petroleum jelly to thrust washer.

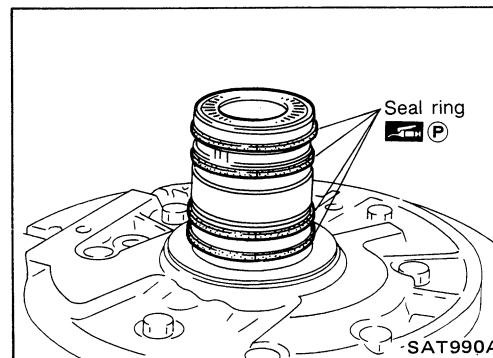

- c. Carefully install seal rings into grooves and press them into the petroleum jelly so that they are a tight fit.

Assembly (Cont'd)

d. Install O-ring on oil pump assembly.

- Apply petroleum jelly to O-ring.

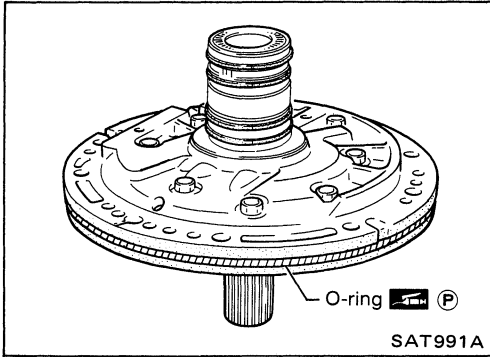

e. Apply petroleum jelly to mating surface of transmission case and oil pump assembly.

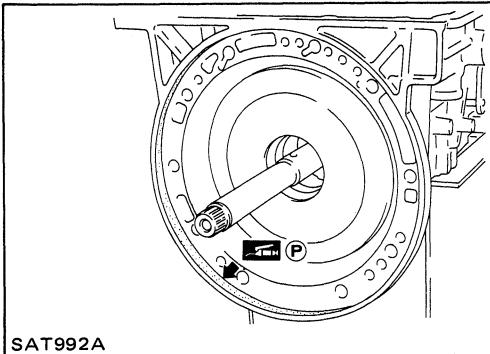

f. Install oil pump assembly.

- Install two converter housing securing bolts in bolt holes in oil pump assembly as guides.

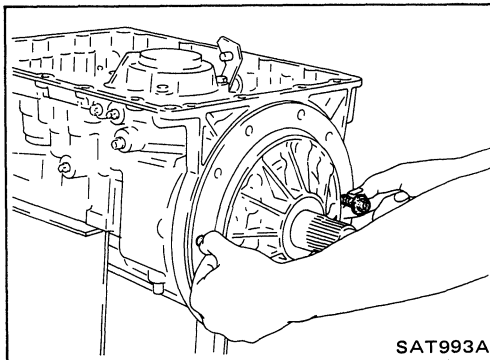

- Insert oil pump assembly to the specified position in transmission, as shown at left.

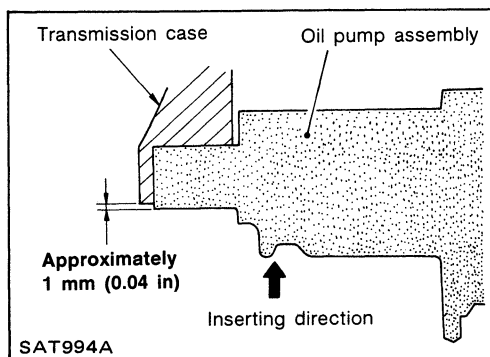

6. Install O-ring on input shaft.

- Apply A.T.F. to O-rings.

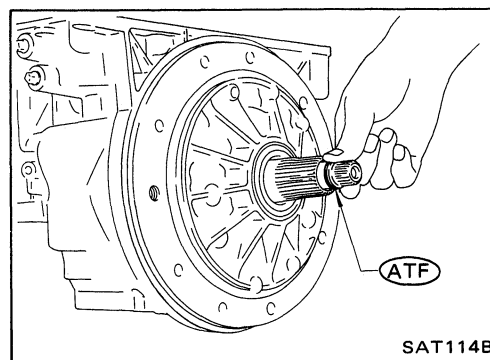

Assembly (Cont'd)

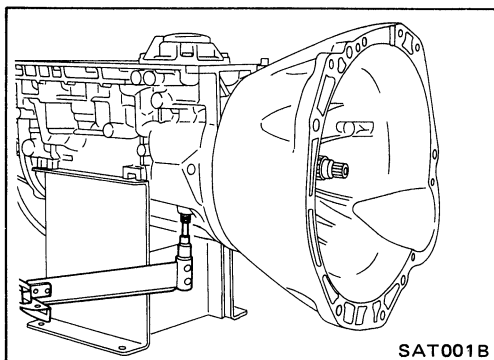
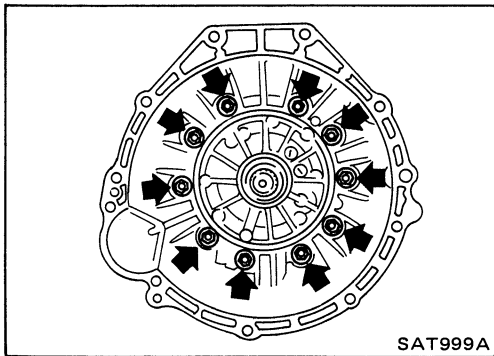
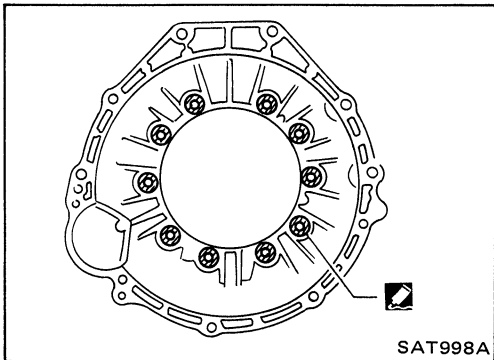
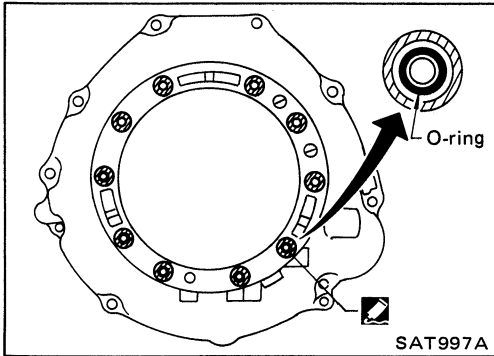
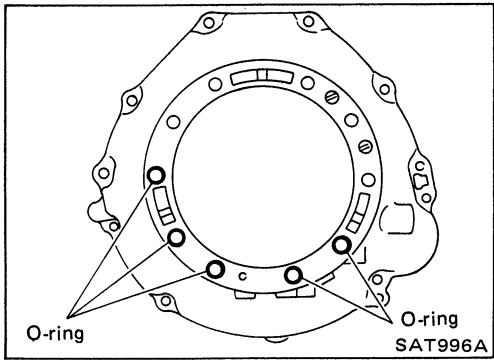

7. Install converter housing.
 - a. Install O-rings on converter housing.
 - b. Apply recommended sealant (Nissan genuine part: KP610-00250 or equivalent) to outer periphery of bolt holes in converter housing.
 - Do not apply too much sealant.
 - c. Apply recommended sealant (Nissan genuine part: KP610-00250 or equivalent) to seating surfaces of bolts that secure front of converter housing.
 - d. Install converter housing on transmission case.
8. Adjust brake band.
 - a. Tighten anchor end bolt to specified torque.
 - ☞: Anchor end bolt
 - 4 - 6 N·m
 - (0.4 - 0.6 kg-m, 2.9 - 4.3 ft-lb)
 - b. Back off anchor end bolt two and a half turns.

Assembly (Cont'd)

c. While holding anchor end pin, tighten lock nut.

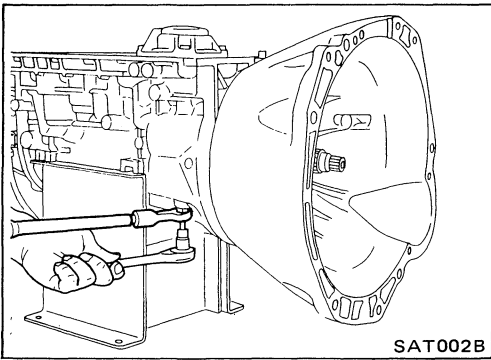

SAT002B

9. Install terminal cord assembly.

a. Install O-ring on terminal cord assembly.

● Apply petroleum jelly to O-ring.

b. Compress terminal cord assembly stopper and install terminal cord assembly on transmission case.

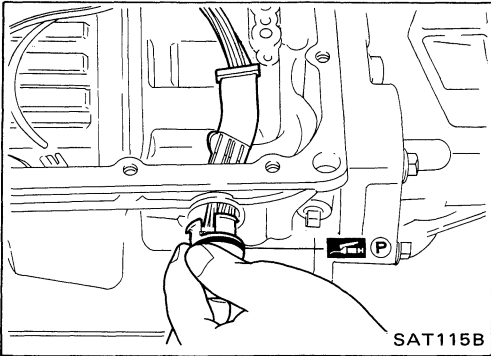

SAT115B

10. Install control valve assembly.

a. Install accumulator piston return springs B, C and D.

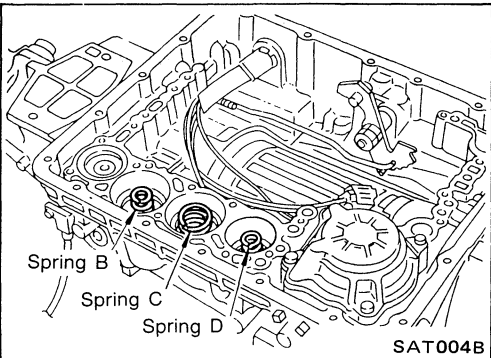

SAT004B

Free length of return springs

Unit: mm (in)

Item	Accumulator	B	C	D
Free length		66 (2.60)	45 (1.77)	58 (2.28)

b. Install manual valve on control valve.

● Apply A.T.F. to manual valve.

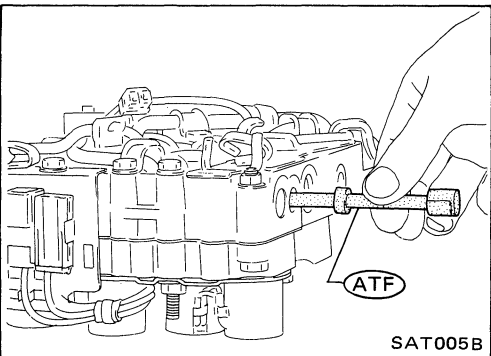

SAT005B

c. Place control valve assembly on transmission case. Connect solenoid connector for upper body.

d. Install connector clip.

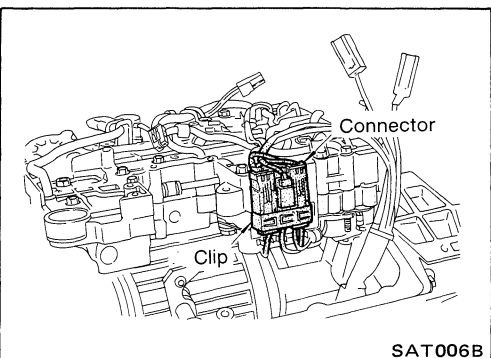

SAT006B

Assembly (Cont'd)

- e. Install control valve assembly on transmission case.
- f. Install connector tube brackets and tighten bolts **(A)** and **(B)**.
- **Check that terminal assembly harness does not catch.**

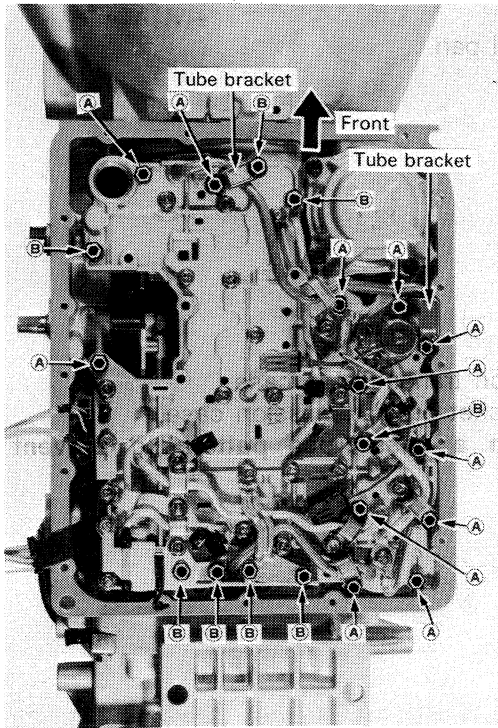

Bolt	Length
(A)	37 mm (1.46 in)
(B)	50 mm (1.97 in)

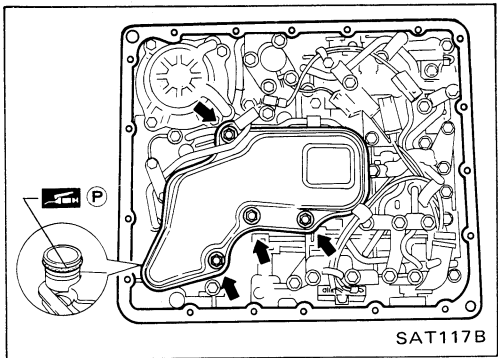

- g. Install O-ring on oil strainer.
- **Apply petroleum jelly to O-ring.**
- h. Install oil strainer on control valve.

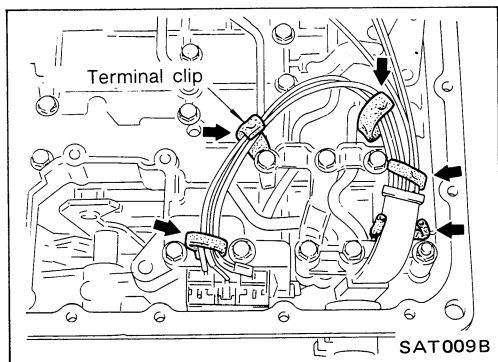

- i. Securely fasten terminal harness with clips.

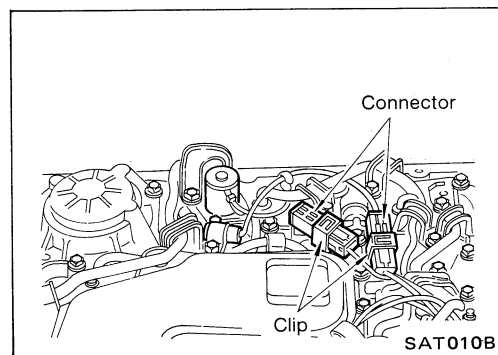

- j. Install lock-up solenoid and fluid temperature sensor 1 and 2 connectors.

Assembly (Cont'd)

11. Install oil pan.
 a. Attach a magnet to oil pan.

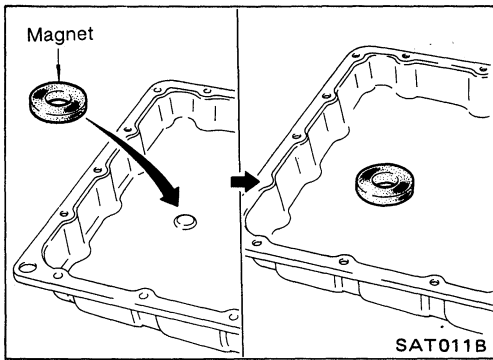

- b. Install oil pan gasket on transmission case.
 c. Install oil pan and bracket on transmission case.
 ● **Tighten four bolts in a criss-cross pattern to prevent dislocation of gasket.**

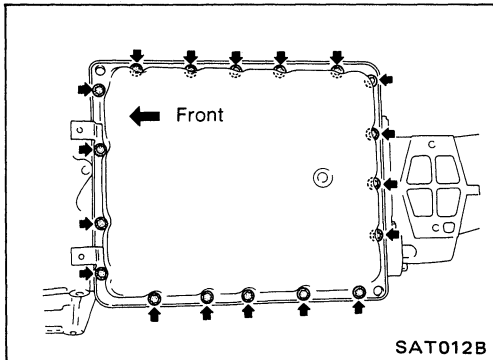

12. Install inhibitor switch.
 a. Check that manual shaft is in "1" range.
 b. Temporarily install inhibitor switch on manual shaft.
 c. Move manual shaft to "N".

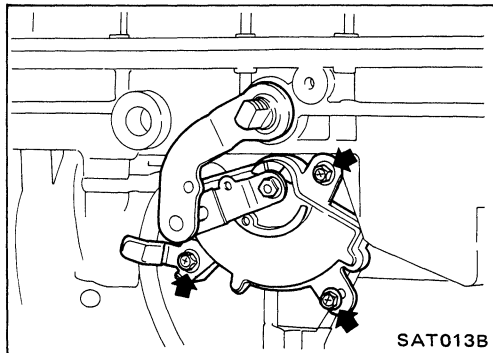

- d. Tighten bolts while inserting 4.0 mm (0.157 in) dia. pin vertically into locating holes in inhibitor switch and manual shaft.

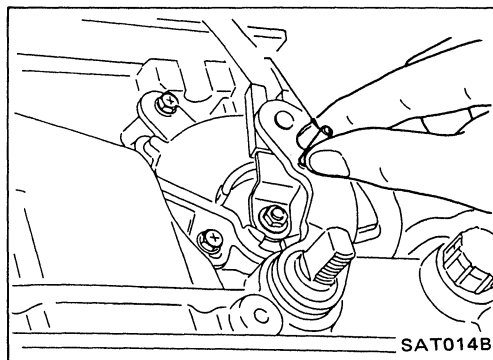

13. Install torque converter.
 a. Pour A.T.F. into torque converter.
 ● **Approximately 2 liters (2-1/8 US qt, 1-3/4 Imp qt) of fluid are required for a new torque converter.**
 ● **When reusing old torque converter, add the same amount of fluid as was drained.**

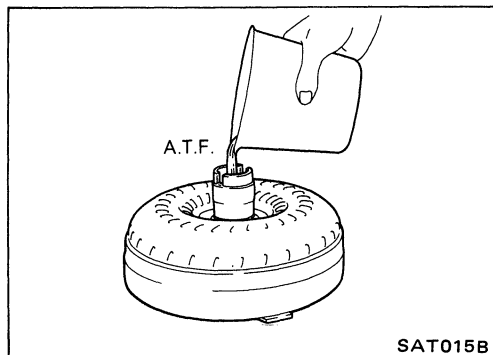

Assembly (Cont'd)

b. Install torque converter while aligning notches and oil pump.

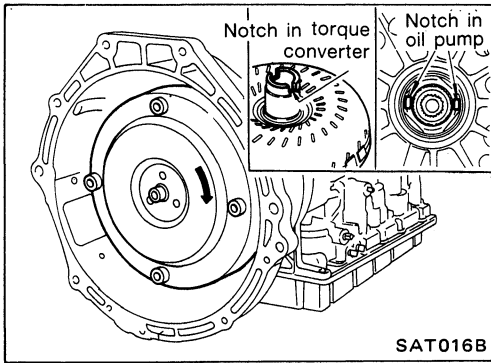

c. Measure distance A to check that torque converter is in proper position.

Distance "A":

26.0 mm (1.024 in) or more

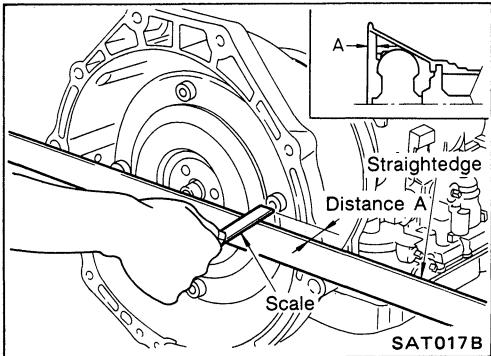

SERVICE DATA AND SPECIFICATIONS (S.D.S.)

General Specifications

Applied model	Z24i		VG30i		
	2WD				4WD
	Floor shift	Column shift	Floor shift	Column shift	Floor shift
Automatic transmission model	L4N71B		E4N71B		RE4R01A
Transmission model code number	X8217	X8218	X8210	X8211	45X19
Stall torque ratio	2.0 : 1				
Transmission gear ratio					
1st	2.842				3.027
2nd	1.542				1.619
Top	1.000				1.000
O.D.	0.686				0.694
Reverse	2.400				2.272
Recommended oil	Automatic transmission fluid Type DEXRON™				
Oil capacity ℓ (US qt, Imp qt)	7.0 (7-3/8, 6-1/8)				8.5 (9, 7-1/2)

Specifications and Adjustment—L4N71B and E4N71B

Transmission model code number	X8217	X8218	X8210	X8211
Torque converter assembly Stamped mark on the torque converter	GYA	GYA	GXA	GXA
Direct clutch				
Number of drive plates	2	2	2	2
Number of driven plates	2	2	2	2
Clearance mm (in)				
Standard	0 - 0.2 (0 - 0.008)			
Allowable limit	0.2 (0.008)			
Drive plate thickness mm (in)				
Standard	1.50 - 1.65 (0.0591 - 0.0650)			
Allowable limit	1.4 (0.055)			
Thickness of race side	Thickness mm (in)		Part number	
	0.4 (0.016)		31606-X8501	
	0.6 (0.024)		31606-X8502	
	0.8 (0.031)		31606-X8500	
	1.0 (0.039)		31606-X8503	
	1.2 (0.047)		31606-X8504	

SERVICE DATA AND SPECIFICATIONS (S.D.S.)

Specifications and Adjustment—L4N71B and E4N71B (Cont'd)

Transmission model code number	X8217	X8218	X8210	X8211
Front clutch				
Number of drive plates	3		3	
Number of driven plates	5		5	
Clearance Standard Allowable limit	mm (in) 1.6 - 1.8 (0.063 - 0.071) 2.2 (0.087)			
Drive plate thickness Standard Allowable limit	mm (in) 1.50 - 1.65 (0.0591 - 0.0650) 1.4 (0.055)			
Thickness of retaining plate	Thickness mm (in)		Part number	
	5.0 (0.197)		31567-X2900	
	5.2 (0.205)		31567-X2901	
	5.4 (0.213)		31567-X2902	
	5.6 (0.220)		31567-X2903	
	5.8 (0.228)		31567-X2904	
	6.0 (0.236)		31567-X2905	
6.2 (0.244)		31567-X2906		
Rear clutch				
Number of drive plates	6		6	
Number of driven plates	6		6	
Clearance Standard Allowable limit	mm (in) 0.8 - 1.0 (0.031 - 0.039) 2.0 (0.079)			
Drive plate thickness Standard Allowable limit	mm (in) 1.50 - 1.65 (0.0591 - 0.0650) 1.4 (0.055)			
Thickness of retaining plate	Thickness mm (in)		Part number	
	6.2 (0.244)		31567-X2906	
	6.4 (0.252)		31507-X8600	
	6.6 (0.260)		31507-X8601	
	6.8 (0.268)		31537-X2800	
	7.0 (0.276)		31537-X2801	
	7.2 (0.283)		31537-X0900	
7.4 (0.291)		31537-X0901		
7.6 (0.299)		31537-X0902		

SERVICE DATA AND SPECIFICATIONS (S.D.S.)

Specifications and Adjustment—L4N71B and E4N71B (Cont'd)

Transmission model code number	X8217	X8218	X8210	X8211
Low & reverse brake Number of drive plates	6		8	
Number of driven plates	6		8	
Clearance Standard Allowable limit	mm (in) 0.8 - 1.05 (0.0315 - 0.0413) 2.0 (0.079)			
Drive plate thickness Standard Allowable limit	mm (in) 1.90 - 2.05 (0.0748 - 0.0807) 1.8 (0.071)			
Thickness of retaining plate	Thickness mm (in)	Part number	Thickness mm (in)	Part number
	11.8 (0.465)	31667-X0300	9.8 (0.386)	31667-X2900
	12.0 (0.472)	31667-X0301	10.0 (0.394)	31667-X2901
	12.2 (0.480)	31667-X0302	10.2 (0.402)	31667-X2902
	12.4 (0.488)	31667-X0303	10.4 (0.409)	31667-X2903
	12.6 (0.496)	31667-X0304	10.6 (0.417)	31667-X2904
	12.8 (0.504)	31667-X0305	10.8 (0.425)	31667-X2905
2nd brake band Piston size Big dia. Small dia.	mm (in) 80 (3.15) 44 (1.73)		mm (in) 80 (3.15) 54 (2.13)	
O.D. brake band Piston size Big dia. Small dia.	mm (in) 60 (2.36) 40 (1.57)		mm (in) 60 (2.36) 40 (1.57)	
Front end play	mm (in) 0.5 - 0.8 (0.020 - 0.031)			
Thickness of front clutch thrust washer	Thickness mm (in)		Part number	
	1.3 (0.051)		31528-X0107	
	1.5 (0.059)		31528-X0105	
	1.7 (0.067)		31528-X0106	
	1.9 (0.075)		31528-X0100	
	2.1 (0.083)		31528-X0101	
	2.3 (0.091)		31528-X0102	
2.5 (0.098)		31528-X0103		
2.7 (0.106)		31528-X0104		

SERVICE DATA AND SPECIFICATIONS (S.D.S.)

Specifications and Adjustment—L4N71B and E4N71B (Cont'd)

Total end play	mm (in)	0.25 - 0.50 (0.0098 - 0.0197)	
Thickness of oil pump cover bearing race	Thickness	mm (in)	Part number
		1.2 (0.047)	31556-X0100
		1.4 (0.055)	31556-X0101
		1.6 (0.063)	31556-X0102
		1.8 (0.071)	31556-X0103
		2.0 (0.079)	31556-X0104
		2.2 (0.087)	31556-X0105
O.D. pack end play	mm (in)	0.5 - 0.8 (0.020 - 0.031)	
Thickness of O.D. thrust washer	Thickness	mm (in)	Part number
		1.3 (0.051)	31528-X8607
		1.5 (0.059)	31528-X8605
		1.7 (0.067)	31528-X8606
		1.9 (0.075)	31528-X8600
		2.1 (0.083)	31528-X8601
		2.3 (0.091)	31528-X8602
		2.5 (0.098)	31528-X8603
	2.7 (0.106)	31528-X8604	
O.D. total end play	mm (in)	0.25 - 0.50 (0.0098 - 0.0197)	
Thickness of O.D. bearing race	Thickness	mm (in)	Part number
		1.2 (0.047)	31603-X8600
		1.4 (0.055)	31603-X8601
		1.6 (0.063)	31603-X8602
		1.8 (0.071)	31603-X8603
		2.0 (0.079)	31603-X8604
		2.2 (0.087)	31603-X8605

Oil pump clearance	mm (in)	
Outer gear-pump housing		
Standard		0.05 - 0.20 (0.0020 - 0.0079)
Allowable limit		0.25 (0.0098)
Outer gear-crescent		
Standard		0.14 - 0.21 (0.0055 - 0.0083)
Allowable limit		0.25 (0.0098)
Gear-pump cover		
Standard		0.02 - 0.04 (0.0008 - 0.0016)
Allowable limit		0.08 (0.0031)
Drum support	mm (in)	
Seal ring-ring groove		
Standard		0.05 - 0.20 (0.0020 - 0.0079)
Allowable limit		0.20 (0.0079)
Oil distributor	mm (in)	
Seal ring-ring groove		
Standard		0.04 - 0.16 (0.0016 - 0.0063)
Allowable limit		0.16 (0.0063)
Planetary carrier	mm (in)	
Clearance between pinion washer and planetary carrier		
Standard		0.20 - 0.70 (0.0079 - 0.0276)
Allowable limit		0.80 (0.0315)
Runout of oil pump cover to housing	mm (in)	Less than 0.07 (0.0028)
Runout of oil pump cover to O.D. case	mm (in)	Less than 0.05 (0.0020)

STALL REVOLUTION

Z24i engine	1,800 - 2,100 rpm
VG30i engine	2,000 - 2,300 rpm

SERVICE DATA AND SPECIFICATIONS (S.D.S.)

Tightening Torque—L4N71B and E4N71B

Unit	N·m	kg·m	ft·lb
Transmission installation			
Drive plate to crankshaft	137 - 157	14.0 - 16.0	101 - 116
Drive plate to torque converter	39 - 49	4.0 - 5.0	29 - 36
Converter housing to engine	39 - 49	4.0 - 5.0	29 - 36
Dust cover to converter housing (Z24i engine)	16 - 22	1.6 - 2.2	12 - 16
Gusset to transmission (VG30i engine)	29 - 39	3.0 - 4.0	22 - 29
Gusset to engine (VG30i engine)	39 - 49	4.0 - 5.0	29 - 36
Rear mounting bracket to transmission	} Refer to section EM.		
Rear mounting bracket to rear insulator			
Rear mounting member to body			
Component part			
Transmission case to converter housing	44 - 54	4.5 - 5.5	33 - 40
Transmission case to rear extension	20 - 25	2.0 - 2.5	14 - 18
Oil pan to transmission case	5 - 7	0.5 - 0.7	3.6 - 5.1
2nd servo piston retainer to transmission case	7 - 9	0.7 - 0.9	5.1 - 6.5
2nd piston stem (when adjusting band brake)	12 - 15*1	1.2 - 1.5*1	9 - 11*1
2nd piston stem lock nut	15 - 39	1.5 - 4.0	11 - 29
One-way clutch inner rear to transmission case	13 - 18	1.3 - 1.8	9 - 13
Control valve body to transmission case	5.4 - 7.4	0.55 - 0.75	4.0 - 5.4

Unit	N·m	kg·m	ft·lb
Lower valve body to upper valve body	2.5 - 3.4	0.25 - 0.35	1.8 - 2.5
O.D. servo piston retainer to O.D. case	10 - 15	1.0 - 1.5	7 - 11
O.D. piston stem (when adjusting band brake)	7 - 10*2	0.7 - 1.0*2	5.1 - 7.2*2
O.D. stem lock nut	15 - 39	1.5 - 4.0	11 - 29
Side plate to control valve body	2.5 - 3.4	0.25 - 0.35	1.8 - 2.5
Nut for control valve reamer bolt	5 - 7	0.5 - 0.7	3.6 - 5.1
Oil strainer to lower valve body	3 - 4	0.3 - 0.4	2.2 - 2.9
Governor valve body to oil distributor	5 - 7	0.5 - 0.7	3.6 - 5.1
Oil pump housing to oil pump cover	6 - 8	0.6 - 0.8	4.3 - 5.8
Inhibitor switch to transmission case	5 - 7	0.5 - 0.7	3.6 - 5.1
Manual shaft lock nut	29 - 39	3.0 - 4.0	22 - 29
Oil cooler pipe to transmission case	29 - 49	3.0 - 5.0	22 - 36
Test plug (oil pressure inspection hole)	14 - 21	1.4 - 2.1	10 - 15
Support actuator (parking rod inserting position) to rear extension	8 - 11	0.8 - 1.1	5.8 - 8.0
Drum support to O.D. case	7 - 9	0.7 - 0.9	5.1 - 6.5

*1: Turn back three turns after tightening.

*2: Turn back two turns after tightening.

SERVICE DATA AND SPECIFICATIONS (S.D.S.)

Specifications and Adjustment-RE4R01A

VEHICLE SPEED WHEN SHIFTING GEARS

Model	Throttle position	Shift pattern	Vehicle speed km/h (MPH)						
			D ₁ → D ₂	D ₂ → D ₃	D ₃ → D ₄	D ₄ → D ₃	D ₃ → D ₂	D ₂ → D ₁	1 ₂ → 1 ₁
VG30i 4WD	Full throttle	Standard	50 - 54 (31 - 34)	93 - 101 (58 - 63)	150 - 160 (93 - 99)	145 - 155 (90 - 96)	86 - 94 (53 - 58)	38 - 42 (24 - 26)	38 - 42 (24 - 26)
		Power	50 - 54 (31 - 34)	93 - 101 (58 - 63)	150 - 160 (93 - 99)	145 - 155 (90 - 96)	86 - 94 (53 - 58)	38 - 42 (24 - 26)	38 - 42 (24 - 26)
	Half throttle	Standard	31 - 35 (19 - 22)	60 - 66 (37 - 41)	99 - 107 (62 - 66)	63 - 71 (39 - 44)	29 - 35 (18 - 22)	10 - 14 (6 - 9)	38 - 42 (24 - 26)
		Power	42 - 46 (26 - 29)	84 - 90 (52 - 56)	119 - 127 (74 - 79)	104 - 112 (65 - 70)	55 - 61 (34 - 38)	10 - 14 (6 - 9)	38 - 42 (24 - 26)

VEHICLE SPEED WHEN PERFORMING AND RELEASING LOCK-UP

Model	Throttle position	Shift pattern	D ₄	
			Vehicle speed km/h (MPH)	
			Lock-up "ON"	Lock-up "OFF"
VG30i 4WD	Full throttle	Standard	150 - 160 (93 - 99)	145 - 155 (90 - 96)
		Power	150 - 160 (93 - 99)	145 - 155 (90 - 96)
	Half throttle	Standard	101 - 109 (63 - 68)	71 - 79 (44 - 49)
		Power	119 - 127 (74 - 79)	104 - 112 (65 - 70)

STALL REVOLUTION

Model	Stall revolution rpm
VG30i 4WD	2,240 - 2,440

LINE PRESSURE

Model	Engine speed rpm	Line pressure kPa (kg/cm ² , psi)	
		D, 2 and 1 ranges	R range
VG30i 4WD	Idle	432 - 471 (4.4 - 4.8, 63 - 68)	667 - 706 (6.8 - 7.2, 97 - 102)
	Stall	883 - 961 (9.0 - 9.8, 128 - 139)	1,393 - 1,471 (14.2 - 15.0, 202 - 213)

SERVICE DATA AND SPECIFICATIONS (S.D.S.)

Specifications and Adjustment-RE4R01A (Cont'd)

RETURN SPRINGS

Unit: mm (in)

Parts	Item	Part No.	Free length	Outer diameter
Control valve	Torque converter relief valve spring	31742-41X18	32.3 (1.272)	9.0 (0.354)
	Pressure regulator valve spring	31742-41X16	61.5 (2.421)	8.9 (0.350)
	Pressure modifier valve spring	31742-41X19	31.95 (1.2579)	6.8 (0.268)
	Accumulator control plug spring	31742-41X17	27.5 (1.083)	6.6 (0.260)
	Shuttle shift valve D spring	31762-41X00	26.5 (1.043)	6.0 (0.236)
	4-2 sequence valve spring	31756-41X00	29.1 (1.146)	6.95 (0.2736)
	Shift valve B spring	31762-41X01	25.0 (0.984)	7.0 (0.276)
	4-2 relay valve spring	31756-41X00	29.1 (1.146)	6.95 (0.2736)
	Shift valve A spring	31762-41X01	25.0 (0.984)	7.0 (0.276)
	Overrun clutch control valve spring	31762-41X03	23.6 (0.929)	7.0 (0.276)
	Overrun clutch reducing valve spring	31742-41X20	32.5 (1.280)	7.0 (0.276)
	Shuttle shift valve S spring	31762-41X04	51.0 (2.008)	5.65 (0.2224)
	Pilot valve spring	31742-41X13	25.7 (1.012)	9.1 (0.358)
	Lock-up control valve spring	31742-41X21	33.0 (1.299)	6.5 (0.256)
	Modifier accumulator piston spring	31742-41X15	30.5 (1.201)	9.8 (0.386)
	1st reducing valve spring	31756-41X05	25.4 (1.000)	6.75 (0.2657)
	3-2 timing valve spring	31742-41X08	20.55 (0.8091)	6.75 (0.2657)
Servo charger valve spring	31742-41X06	23.0 (0.906)	6.7 (0.264)	
Reverse clutch	16 pcs	31505-41X02	19.69 (0.7752)	11.6 (0.457)
High clutch	16 pcs	31505-21X03	22.06 (0.8685)	11.6 (0.457)
Forward clutch (Overrun clutch)	20 pcs	31505-41X01	35.77 (1.4083)	8.0 (0.315)
Low & reverse brake	18 pcs	31521-21X00	23.7 (0.933)	11.6 (0.457)
Band servo	Spring A	31605-41X05	45.6 (1.795)	34.3 (1.350)
	Spring B	31605-41X00	53.8 (2.118)	40.3 (1.587)
	Spring C	31605-41X01	29.0 (1.142)	27.6 (1.087)
Accumulator	Accumulator A	31605-41X02	43.0 (1.693)	
	Accumulator B	31605-41X10	66.0 (2.598)	
	Accumulator C	31605-41X09	45.0 (1.772)	
	Accumulator D	31605-41X06	58.0 (2.283)	

SERVICE DATA AND SPECIFICATIONS (S.D.S.)

Specifications and Adjustment-RE4R01A (Cont'd)

ACCUMULATOR O-RING

Accumulator	Diameter mm (in)			
	A	B	C	D
Small diameter end	29 (1.14)	32 (1.26)	45 (1.77)	29 (1.14)
Large diameter end	45 (1.77)	50 (1.97)	50 (1.97)	45 (1.77)

CLUTCHES AND BRAKES

Reverse clutch		
Number of drive plates	2	
Number of driven plates	2	
Thickness of drive plate mm (in)		
Standard	2.0 (0.079)	
Wear limit	1.8 (0.071)	
Clearance mm (in)		
Standard	0.5 - 0.8 (0.020 - 0.031)	
Allowable limit	1.2 (0.047)	
Thickness of retaining plate	Thickness mm (in)	Part number
	4.6 (0.181)	31537-21X00
	4.8 (0.189)	31537-21X01
	5.0 (0.197)	31537-21X02
	5.2 (0.205)	31537-21X03
	5.4 (0.213)	31537-21X04
	5.6 (0.220)	31537-21X13
	5.8 (0.228)	31537-21X14
High clutch		
Number of drive plates	4	
Number of driven plates	7	
Thickness of drive plate mm (in)		
Standard	1.6 (0.063)	
Wear limit	1.4 (0.055)	
Clearance mm (in)		
Standard	1.8 - 2.2 (0.071 - 0.087)	
Allowable limit	3.0 (0.118)	
Thickness of retaining plate	Thickness mm (in)	Part number
	3.0 (0.118)	31537-41X69
	3.2 (0.126)	31537-41X70
	3.4 (0.134)	31537-41X71
	3.6 (0.142)	31537-41X61
	3.8 (0.150)	31537-41X62
	4.0 (0.157)	31537-41X63
	4.2 (0.165)	31537-41X64
4.4 (0.173)	31537-41X65	

Forward clutch		
Number of drive plates	7	
Number of driven plates	7	
Thickness of drive plate mm (in)		
Standard	1.6 (0.063)	
Wear limit	1.4 (0.055)	
Clearance mm (in)		
Standard	0.45 - 0.85 (0.0177 - 0.0335)	
Allowable limit	2.25 (0.0886)	
Thickness of retaining plate	Thickness mm (in)	Part number
	4.0 (0.157)	31537-41X07
	4.2 (0.165)	31537-41X08
	4.4 (0.173)	31537-41X09
	4.6 (0.181)	31537-41X10
	4.8 (0.189)	31537-41X11
	5.0 (0.197)	31537-41X12
	5.2 (0.205)	31537-41X13
Overrun clutch		
Number of drive plates	3	
Number of driven plates	5	
Thickness of drive plate mm (in)		
Standard	2.0 (0.079)	
Wear limit	1.8 (0.071)	
Clearance mm (in)		
Standard	1.0 - 1.4 (0.039 - 0.055)	
Allowable limit	2.0 (0.079)	
Thickness of retaining plate	Thickness mm (in)	Part number
	4.0 (0.157)	31537-41X79
	4.2 (0.165)	31537-41X80
	4.4 (0.173)	31537-41X81
	4.6 (0.181)	31537-41X82
	4.8 (0.189)	31537-41X83
	5.0 (0.197)	31537-41X84
	5.2 (0.205)	31537-41X20

SERVICE DATA AND SPECIFICATIONS (S.D.S.)

Specifications and Adjustment-RE4R01A (Cont'd)

Low & reverse brake		
Number of drive plates	6	
Number of driven plates	6	
Thickness of drive plate mm (in)		
Standard	2.0 (0.079)	
Wear limit	1.8 (0.071)	
Clearance mm (in)		
Standard	1.1 - 1.5 (0.043 - 0.059)	
Allowable limit	2.7 (0.106)	
Thickness of retaining plate	Thickness mm (in)	Part number
	8.0 (0.315)	31667-41X00
	8.2 (0.323)	31667-41X01
	8.4 (0.331)	31667-41X02
	8.6 (0.339)	31667-41X03
	8.8 (0.346)	31667-41X04
	9.0 (0.354)	31667-41X05
	9.2 (0.362)	31667-41X06
	9.4 (0.370)	31667-41X09
9.6 (0.378)	31667-41X10	
Brake band		
Anchor end bolt tightening torque N-m (kg-m, ft-lb)	4 - 6 (0.4 - 0.6, 2.9 - 4.3)	
Number of returning revolutions for anchor end bolt	2.5	

REVERSE CLUTCH DRUM END PLAY

Reverse clutch drum end play "T ₂ "	0.55 - 0.90 mm (0.0217 - 0.0354 in)	
Thickness of oil pump thrust washer	Thickness mm (in)	Part number
	0.7 (0.028)	31528-21X00
	0.9 (0.035)	31528-21X01
	1.1 (0.043)	31528-21X02
	1.3 (0.051)	31528-21X03
	1.5 (0.059)	31528-21X04
	1.7 (0.067)	31528-21X05
1.9 (0.075)	31528-21X06	

REMOVAL AND INSTALLATION

Manual control linkage Number of returning revolutions for lock nut	1
Lock nut tightening torque	4.4 - 5.9 N-m (0.45 - 0.60 kg-m, 3.3 - 4.3 ft-lb)
Distance between end of clutch housing and torque converter	26.0 mm (1.024 in) or more
Drive plate runout limit	0.5 mm (0.020 in)

OIL PUMP AND LOW ONE-WAY CLUTCH

Oil pump clearance mm (in)	
Cam ring — oil pump housing Standard	0.01 - 0.024 (0.0004 - 0.0009)
Rotor, vanes and control piston — oil pump housing Standard	0.03 - 0.044 (0.0012 - 0.0017)
Seal ring clearance mm (in)	
Standard	0.10 - 0.25 (0.0039 - 0.0098)
Allowable limit	0.25 (0.0098)

TOTAL END PLAY

Total end play "T ₁ "	0.25 - 0.55 mm (0.0098 - 0.0217 in)	
Thickness of oil pump cover bearing race	Thickness mm (in)	Part number
	0.8 (0.031)	31429-21X00
	1.0 (0.039)	31429-21X01
	1.2 (0.047)	31429-21X02
	1.4 (0.055)	31429-21X03
	1.6 (0.063)	31429-21X04
	1.8 (0.071)	31429-21X05
	2.0 (0.079)	31429-21X06

TRANSFER

SECTION TF



CONTENTS

PREPARATION	TF- 2
ON-VEHICLE SERVICE	TF- 4
REMOVAL AND INSTALLATION	TF- 7
TRANSFER GEAR CONTROL	TF- 8
MAJOR OVERHAUL	TF- 9
DISASSEMBLY	TF-12
REPAIR FOR COMPONENT PARTS	TF-17
ASSEMBLY	TF-26
SERVICE DATA AND SPECIFICATIONS (S.D.S.)	TF-34

TF

PREPARATION

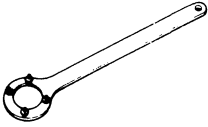
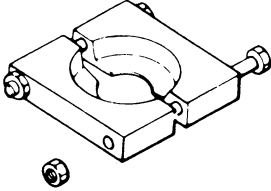
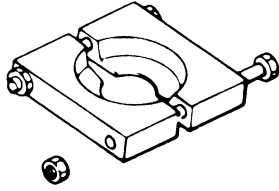
SPECIAL SERVICE TOOLS

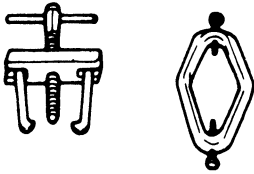
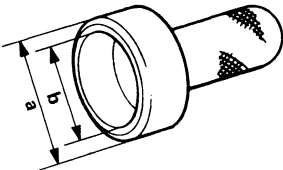
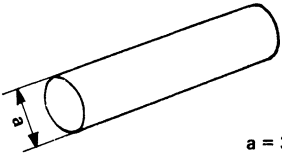
Tool number (Kent-Moore No.) Tool name	Description
ST38060002 (J34311) Flange wrench	 <p>Removing companion flange nut Installing companion flange nut</p>
ST30021000 (J22912-01) Puller	 <p>Removing counter gear front bearing (Use with ST36710010) Removing L & H hub</p>
ST30031000 (J22912-01) Puller	 <p>Removing counter gear rear bearing (Use with ST36710010)</p>
ST33290001 (J25810-A) Puller	 <p>Removing center case oil seal Removing rear oil seal</p>
ST33051001 (J22888) Puller	 <p>Removing companion flange</p>
ST30720000 ① (J25273) ② (J25405) Drift	 <p>① Installing center case oil seal ② Installing rear oil seal</p> <p>a = 77 mm (3.03 in) dia. b = 55.5 mm (2.185 in) dia.</p>
ST36710010 (-) Drift	 <p>Removing counter gear front bearing (Use with ST30021000) Removing counter gear rear bearing (Use with ST30031000)</p> <p>a = 34.5 mm (1.358 in) dia.</p>

PREPARATION

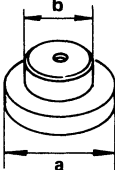
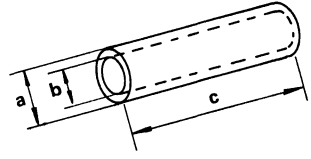
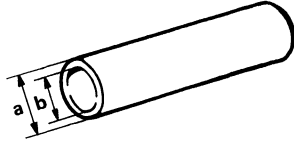
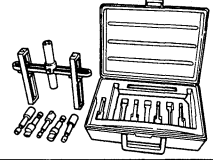
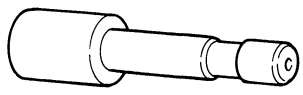
Tool number (Kent-Moore No.) Tool name	Description
ST33061000 (J8107-2) Drift	 <p style="margin-left: 200px;">a: 28.5 mm (1.122 in) dia. b: 38 mm (1.50 in) dia.</p>
ST30613000 ① (J25742-3) ② (J34339) Drift	 <p style="margin-left: 200px;">a: 72 mm (2.83 in) dia. b: 48 mm (1.89 in) dia.</p>
(J35864) Drift	 <p style="margin-left: 200px;">a = 26 mm (1.02 in) dia. b = 20 mm (0.79 in) dia. c = 150 mm (5.91 in)</p>
(J26092) Drift	 <p style="margin-left: 200px;">a = 44.5 mm (1.752 in) dia. b = 38.5 mm (1.516 in) dia.</p>
(J34291) Shim setting gauge set	
(J34291-20) Plunger-shim setting gauge	

COMMERCIAL SERVICE TOOLS

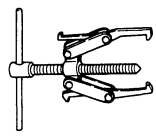
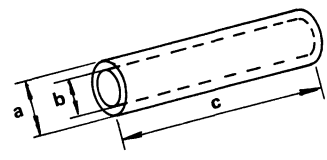
Tool name	Description
Puller	 <p style="margin-left: 200px;">Removing front drive shaft front bearing Removing front drive shaft rear bearing Removing main gear bearing</p>
Drift	 <p style="margin-left: 200px;">① { a = 50 mm (1.97 in) dia. b = 42 mm (1.65 in) dia. c = 180 mm (7.09 in)</p> <p style="margin-left: 200px;">② { a = 60 mm (2.36 in) dia. b = 50 mm (1.97 in) dia. c = 60 mm (2.36 in)</p>

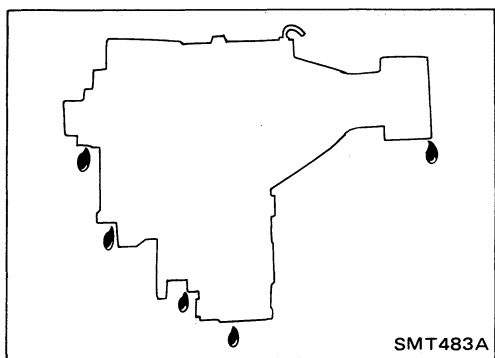

Checking Transfer Oil

- Check transfer for oil leakage.

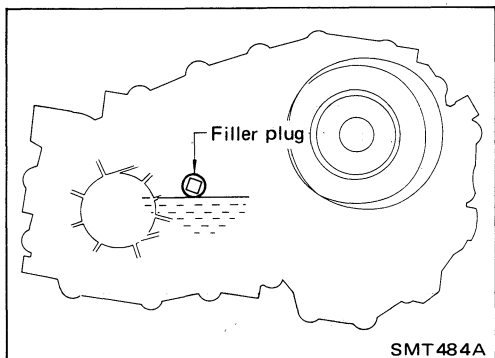

- Check oil level.

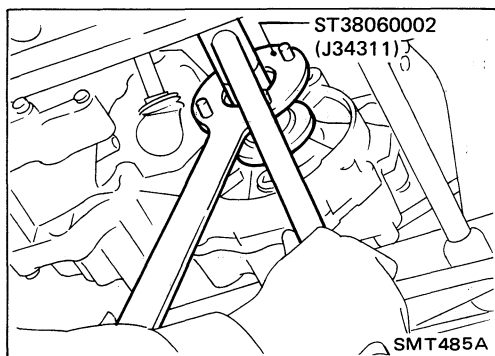

Replacing Oil Seal

CENTER CASE OIL SEAL

1. Remove front propeller shaft. — Refer to PD section.
2. Remove companion flange nut.

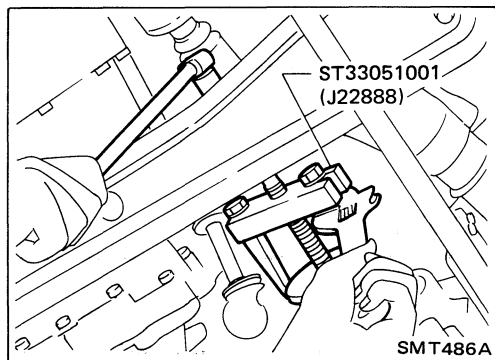

3. Remove companion flange.

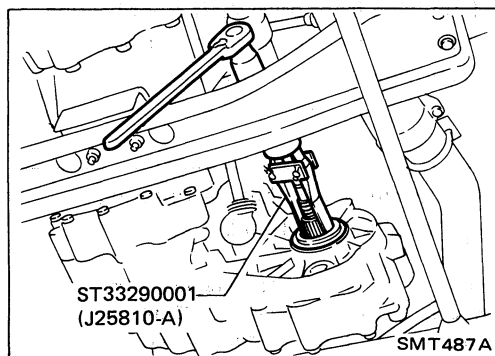

4. Remove center case oil seal.

ON-VEHICLE SERVICE

Replacing Oil Seal (Cont'd)

5. Install center case oil seal.

Before installing, apply multi-purpose grease to seal lip.

6. Install companion flange.

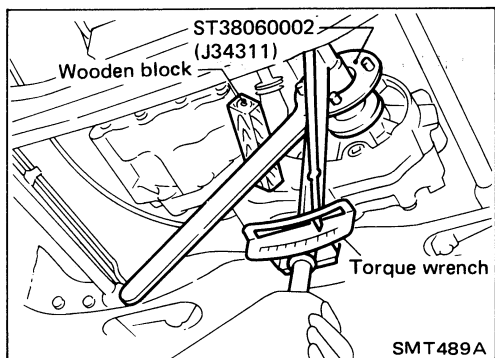
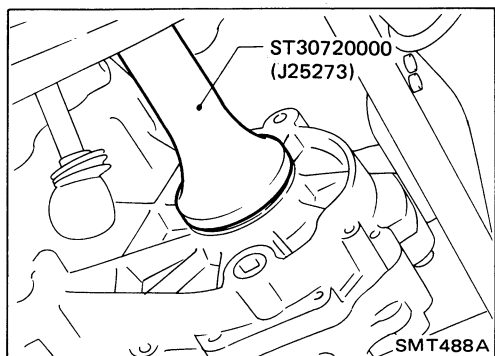

7. Tighten nut to the specified torque.

8. Install front propeller shaft.

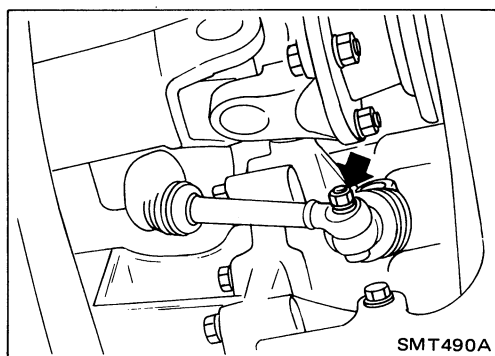

SHIFT SHAFT OIL SEAL

1. Remove front propeller shaft. — Refer to PD section.

2. Remove companion flange. — Refer to center case oil seal service on previous page.

3. Remove transfer control lever from transfer outer shift lever. Then remove outer shift lever.

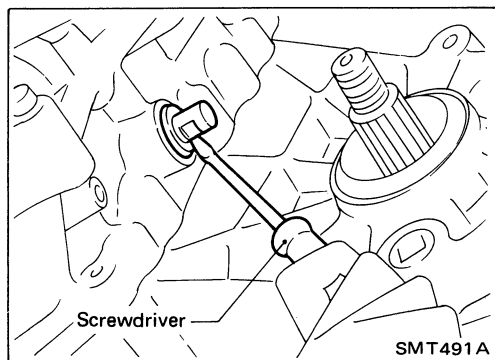

4. Remove shift shaft oil seal.

Be careful not to damage cross shaft.

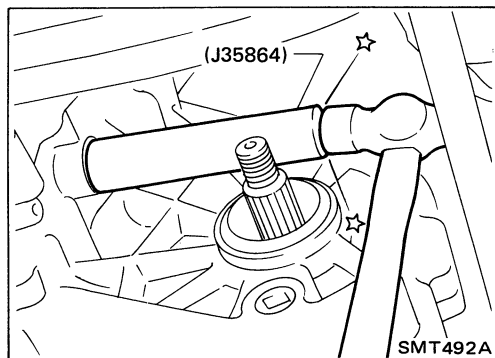

5. Install shift shaft oil seal.

Before installing, apply multi-purpose grease to seal lip.

6. Install transfer control linkage.

7. Install companion flange. — Refer to center case oil seal service on previous page.

8. Install front propeller shaft.

ON-VEHICLE SERVICE

Replacing Oil Seal (Cont'd)

REAR OIL SEAL

1. Remove rear propeller shaft. — Refer to PD section.
2. Remove rear oil seal.

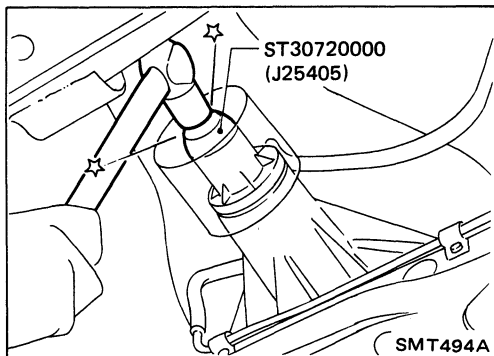
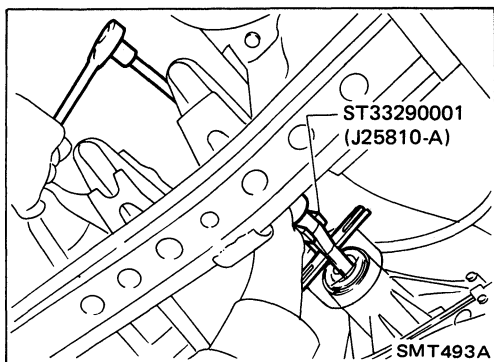

3. Install rear oil seal.

Before installing apply multi-purpose grease to seal lip.

4. Install rear propeller shaft.

REMOVAL AND INSTALLATION

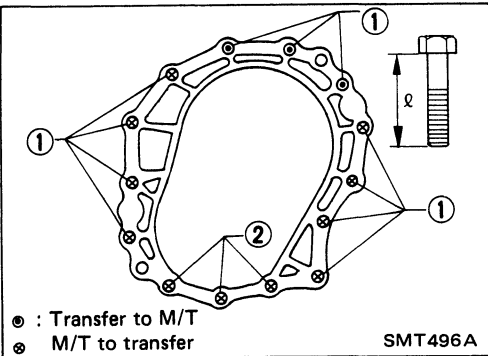
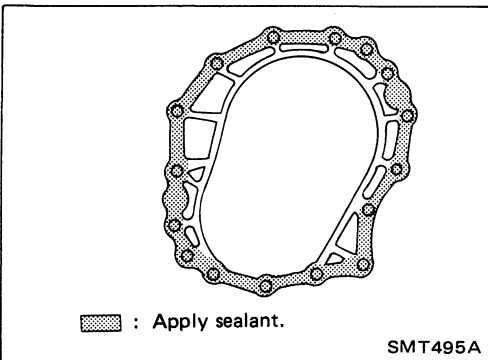
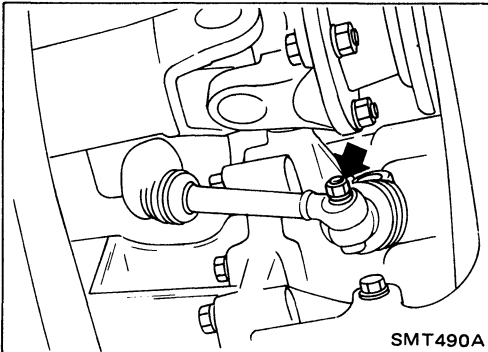
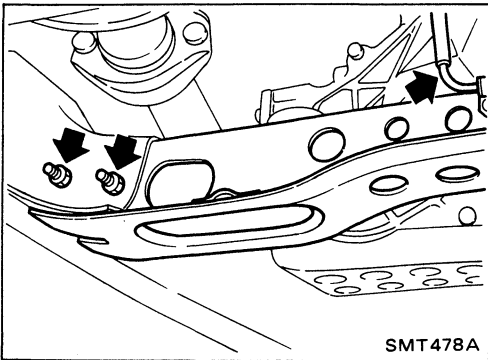

Removal

- Drain oil from transfer and transmission.
- Remove front and rear propeller shaft. — Refer to section PD.

- Insert plug into rear oil seal after removing propeller shaft.

CAUTION:

Be careful not to damage spline, sleeve yoke and rear oil seal, when removing propeller shaft.

- Remove torsion bar spring. — Refer to REMOVAL of Torsion Bar Spring in section FA. Then remove second crossmember.

- Remove transfer control lever from transfer outer shift lever.

- Remove transfer from transmission.

WARNING:

Support transfer while removing it.

Installation

- Apply recommended sealant to mating surface to transmission. (M/T model only)

Recommended sealant:

Nissan genuine part (KP610-00250) or equivalent

- Tighten bolts securing transfer.

M/T model

Bolt No.	Tightening torque N·m (kg·m, ft·lb)	ℓ mm (in)
①	31 - 41 (3.2 - 4.2, 23 - 30)	45 (1.77)
②	31 - 41 (3.2 - 4.2, 23 - 30)	60 (2.36)

A/T model

Bolt No.	Tightening torque N·m (kg·m, ft·lb)	ℓ mm (in)
①	31 - 41 (3.2 - 4.2, 23 - 30)	60 (2.36)
②	31 - 41 (3.2 - 4.2, 23 - 30)	60 (2.36)

TRANSFER GEAR CONTROL

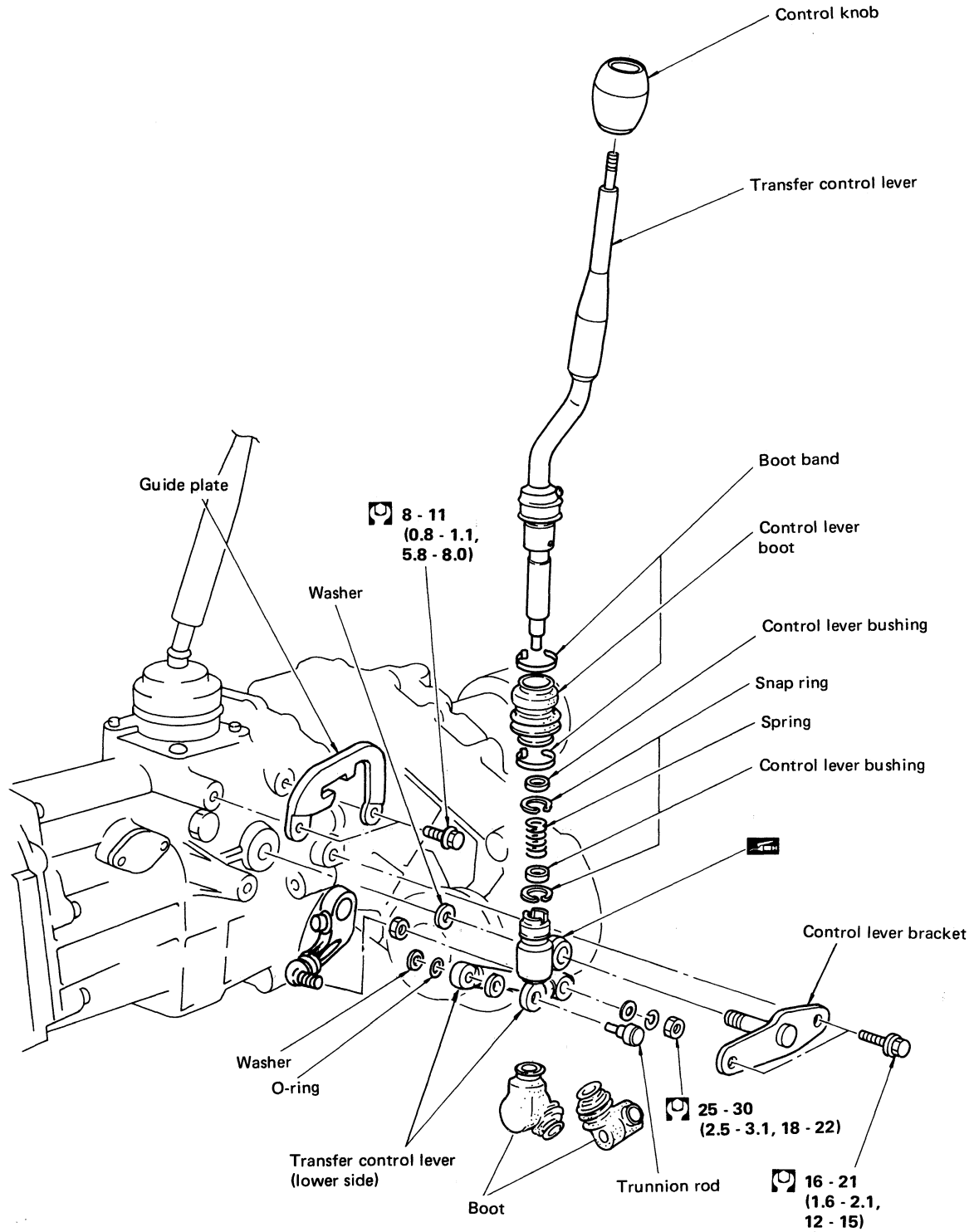

: N-m (kg-m, ft-lb)

SMT062B

Case Components

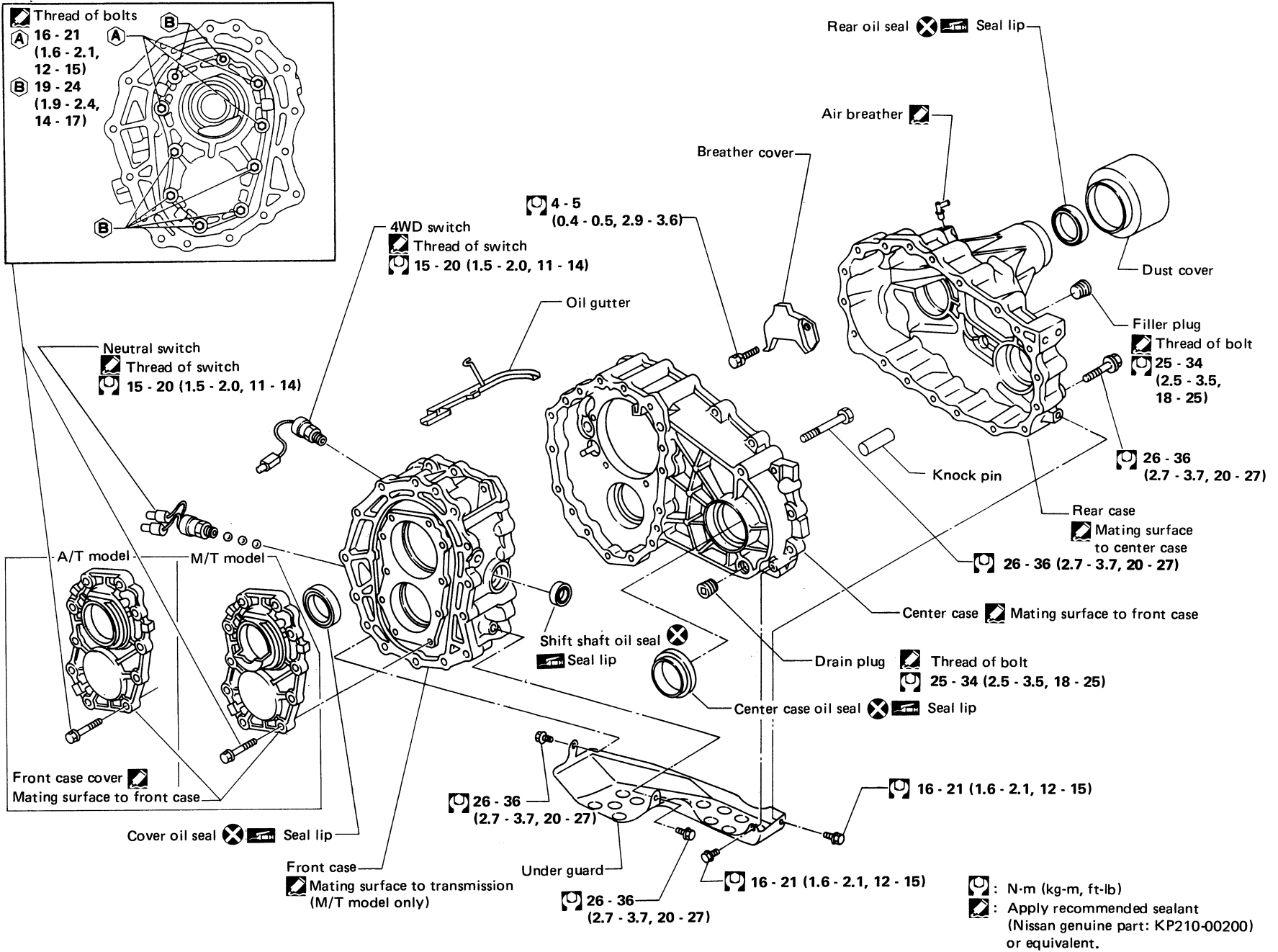

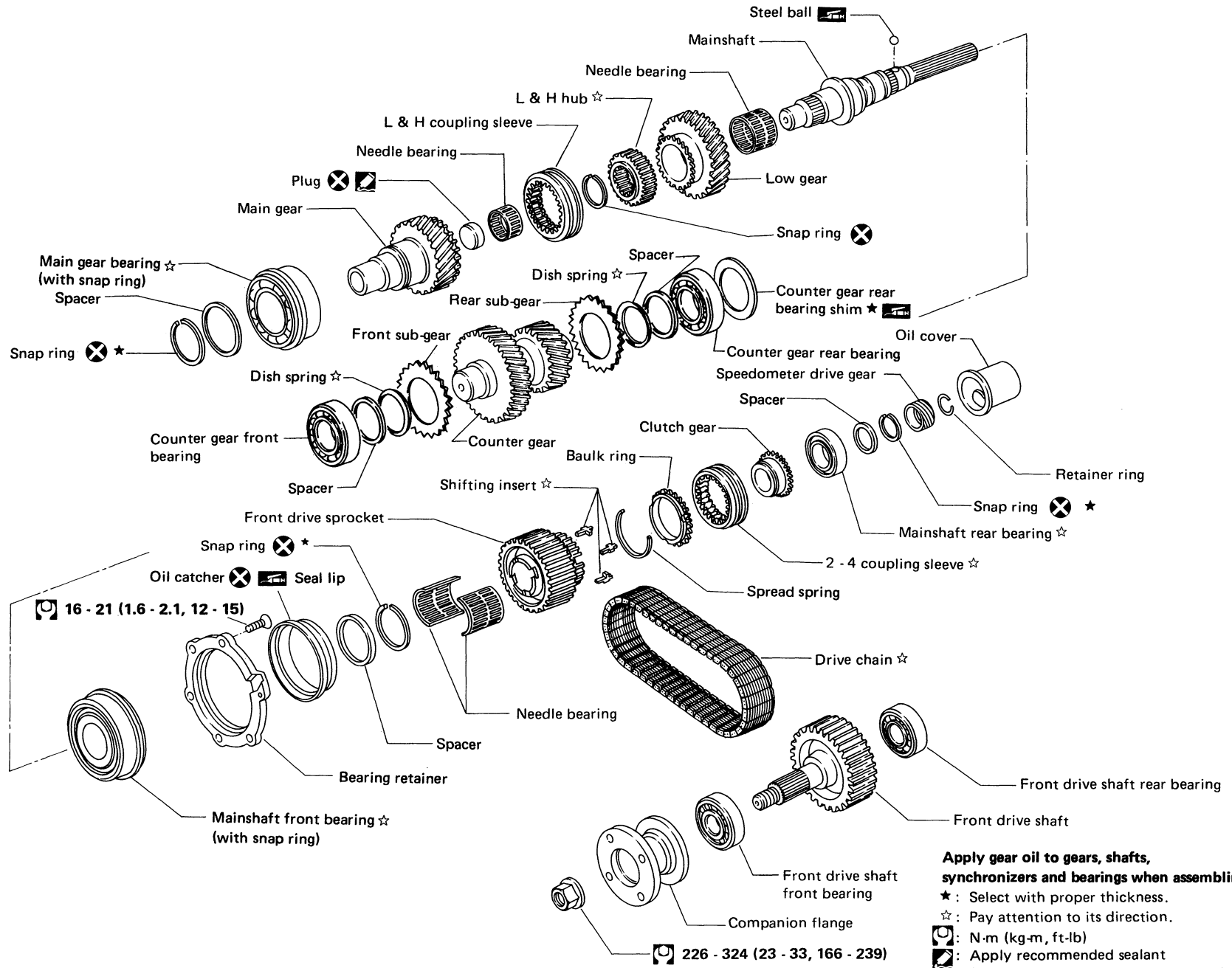

Apply gear oil to gears, shafts, synchronizers and bearings when assembling.
 ★ : Select with proper thickness.
 ☆ : Pay attention to its direction.
 [Symbol: Circle with X] : N-m (kg-m, ft-lb)
 [Symbol: Square with diagonal line] : Apply recommended sealant (Nissan genuine part: KP210-00200) or equivalent.

Shift Control Components

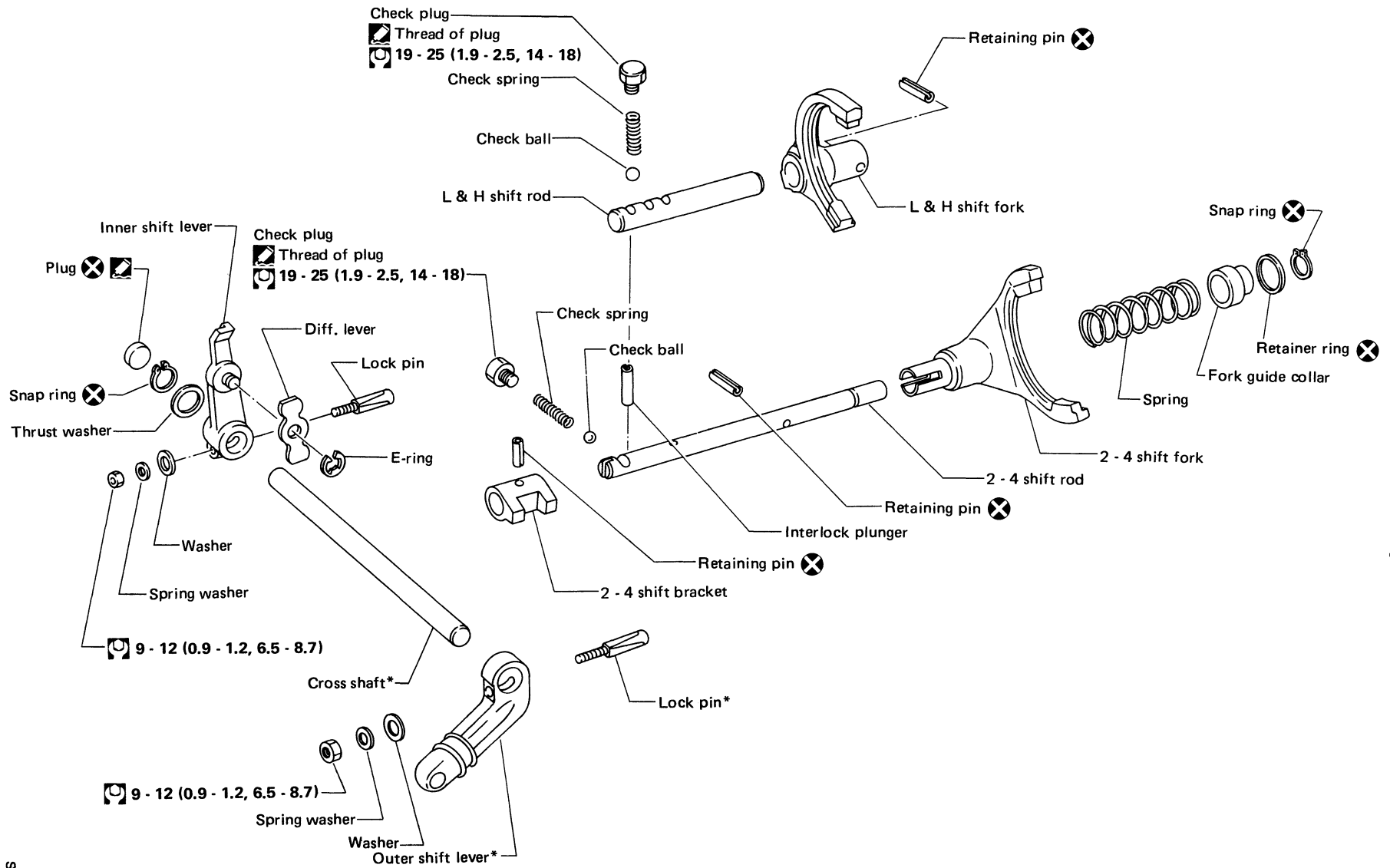

* : If these parts require to be replaced, replace them as a set.
 [Torque symbol] : N-m (kg-m, ft-lb)
 [Sealant symbol] : Apply recommended sealant (Nissan genuine part: KP210-00200) or equivalent.

TF-11

DISASSEMBLY

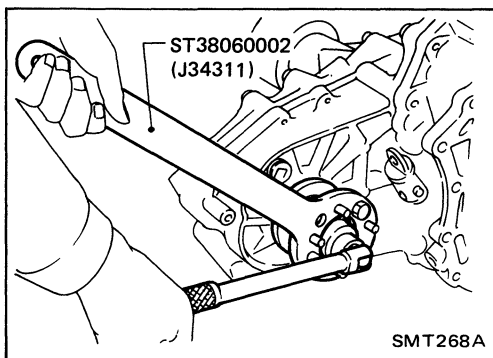

1. Remove nut of companion flange.

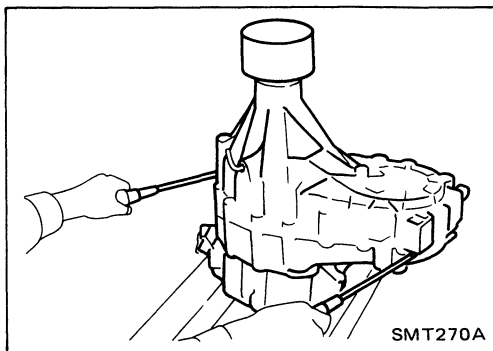

2. Remove rear case.
Be careful not to damage the mating surface.

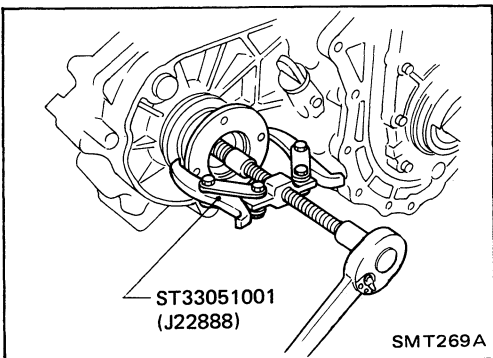

3. Remove companion flange

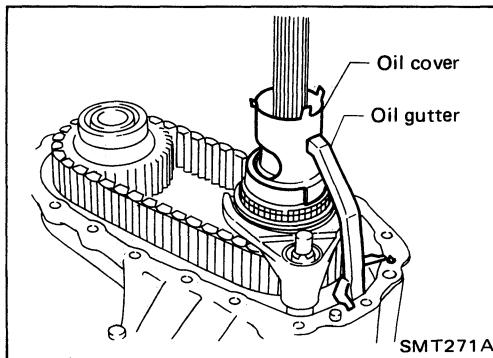

4. Remove oil cover and oil gutter.

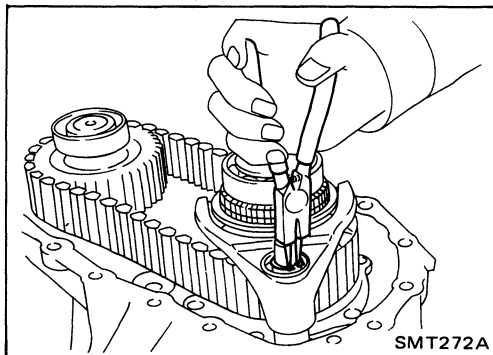

5. Remove snap ring from 2-4 shift rod.

DISASSEMBLY

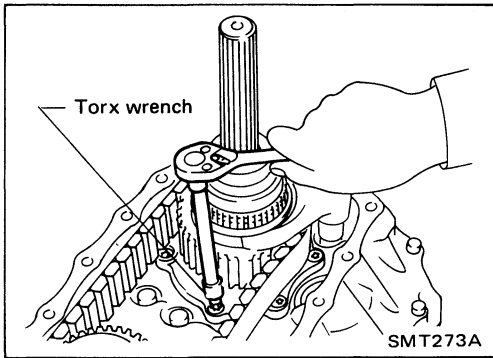

6. Remove bolts securing bearing retainer.
This step is necessary to remove mainshaft from center case.

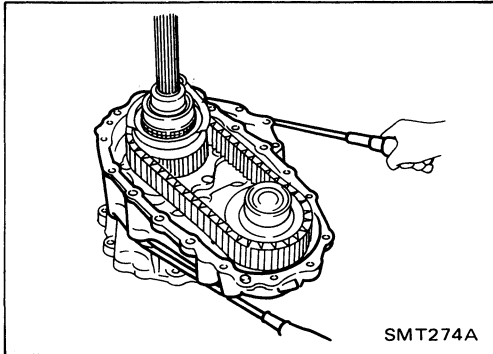

7. Remove bolts securing center case to front case and then separate center case and front case.

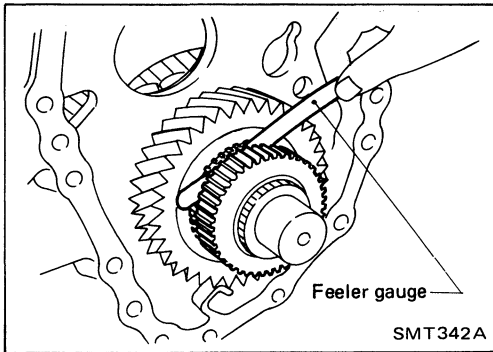

8. Measure end play of low gear.

Standard:

0.2 - 0.35 mm (0.0079 - 0.0138 in)

If end play is beyond the maximum value, check low gear and L & H hub for wear.

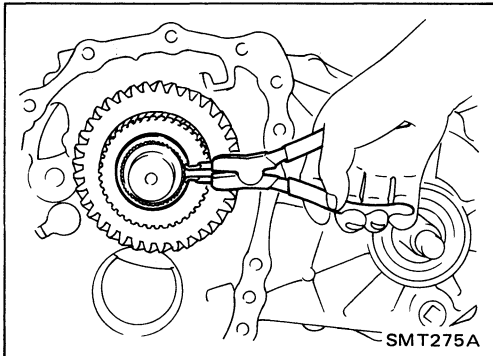

9. Disassemble center case assembly.
 - a. Remove snap ring from mainshaft.

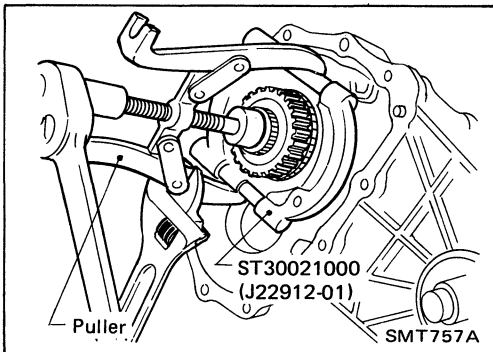

- b. Pull out low gear with L & H hub.

DISASSEMBLY

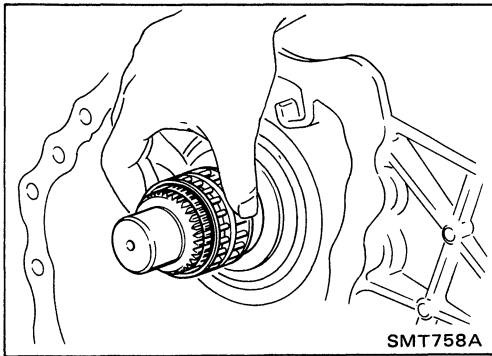

c. Remove needle bearing of low gear.

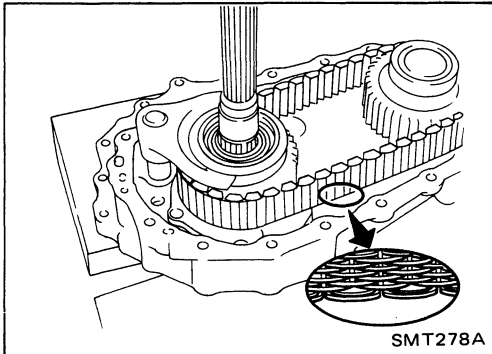

d. Make sure of the direction of the drive chain before removing it. (It must be reinstalled in the same direction.)

Check whether spring part of drive chain is installed on front or rear side.

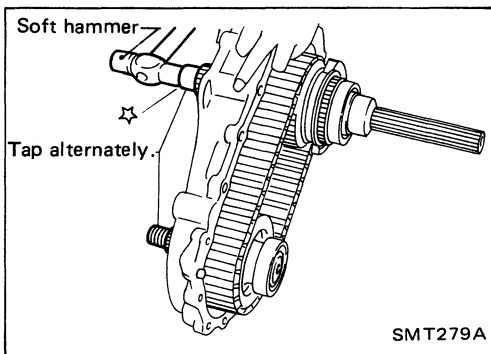

e. Remove mainshaft, front drive and drive chain as a set by tapping front end of mainshaft and front drive shaft alternately.

Be careful not to bend drive chain.

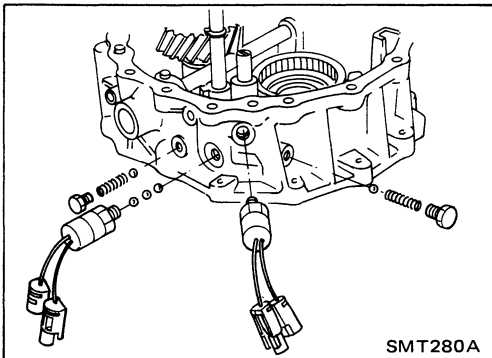

10. Disassemble front case assembly.

a. Remove switches, check plugs, check springs and check balls.

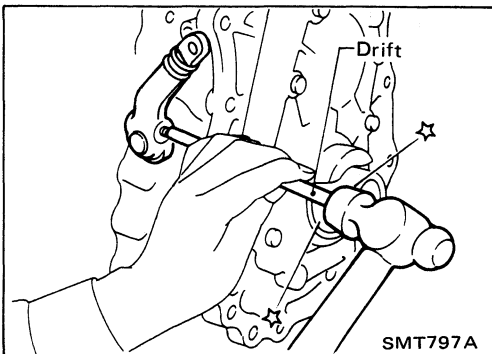

b. Remove outer shift lever.

DISASSEMBLY

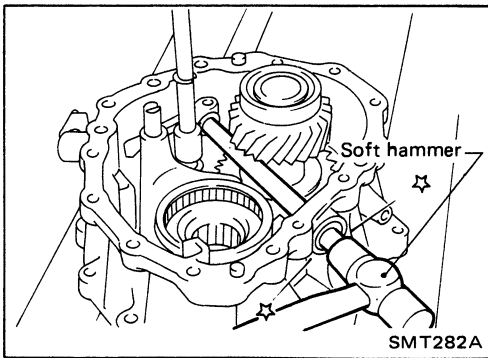

- c. Remove lock pin of inner shift lever and drive out cross shaft with plug.

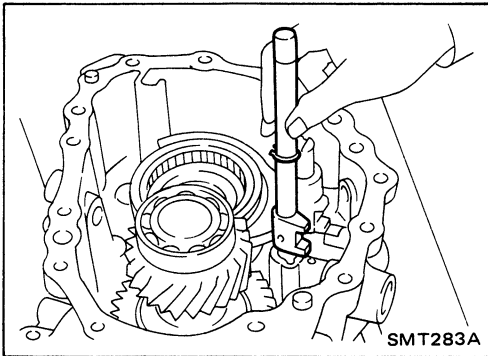

- d. Remove 2-4 shift rod.

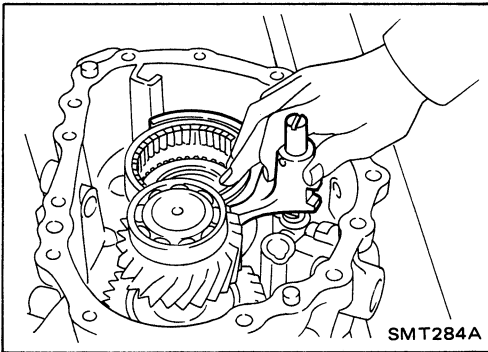

- e. Remove L & H shift rod and fork assembly with coupling sleeve.

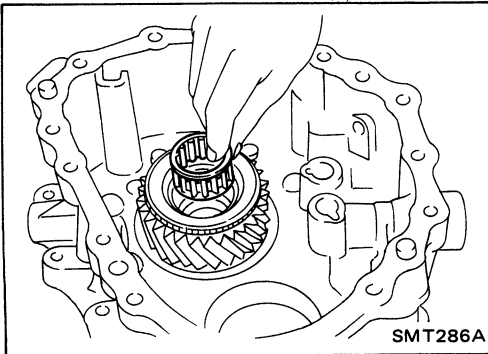

- f. Remove needle bearing from main gear.

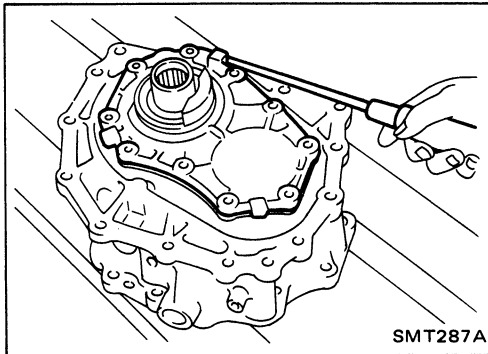

- g. Remove bolts securing front case cover and then remove case.

DISASSEMBLY

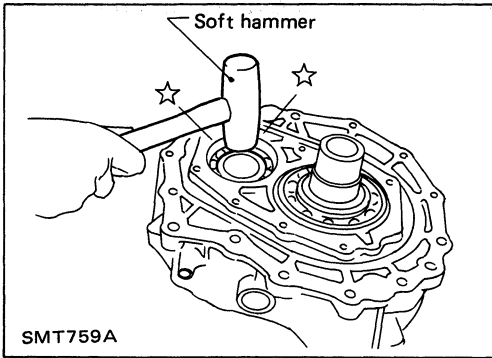

h. Remove counter gear by tapping lightly.

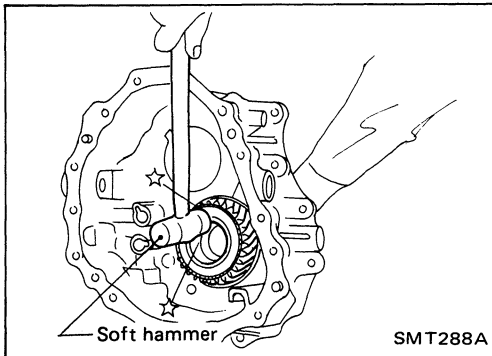

i. Remove main gear by tapping lightly.

REPAIR FOR COMPONENT PARTS

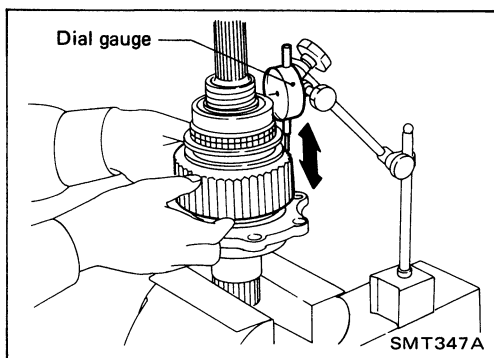

Mainshaft DISASSEMBLY

1. Check end play of front drive sprocket.

Standard:

0.2 - 0.35 mm (0.0079 - 0.0138 in)

If end play is beyond the maximum value, check front drive sprocket and clutch gear for wear.

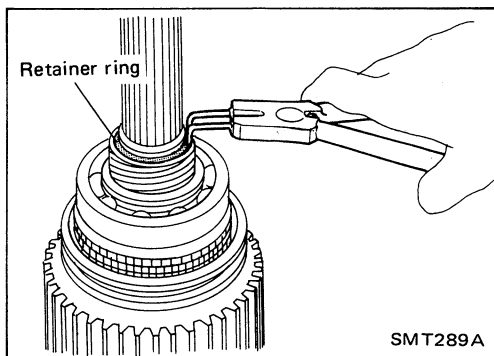

2. Remove retainer ring, speedometer drive gear and steel ball.
Be careful not to lose the steel ball.

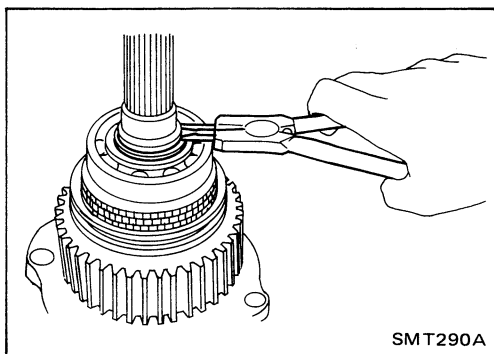

3. Remove snap ring and spacer.

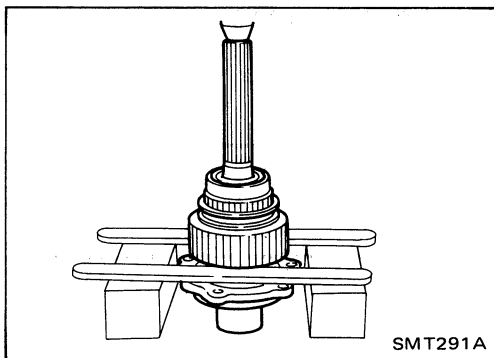

4. Press out front drive sprocket with mainshaft rear bearing and clutch gear together.
5. Remove needle bearing.

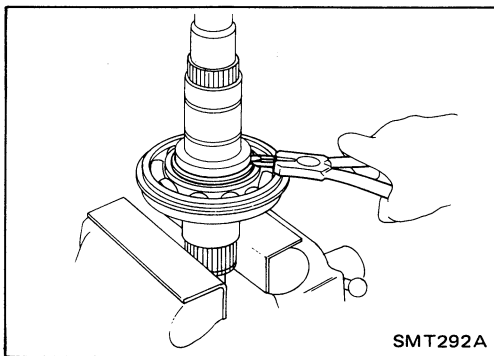

6. Remove bearing retainer and then remove snap ring and spacer.

REPAIR FOR COMPONENT PARTS

Mainshaft (Cont'd)

7. Press out mainshaft front bearing from mainshaft.

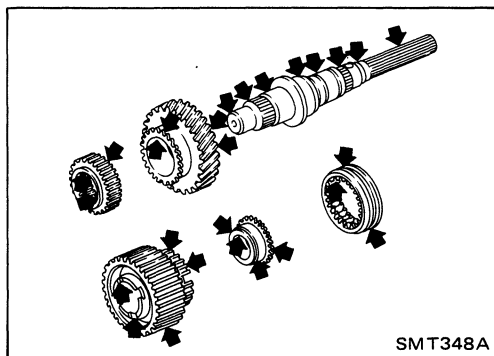
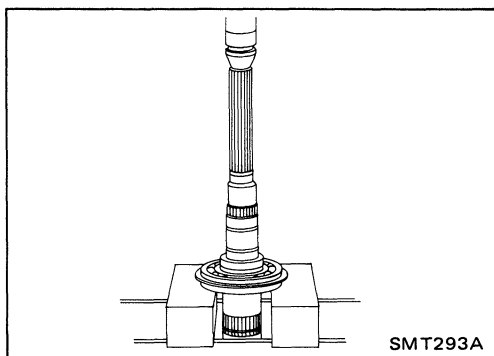

INSPECTION

Gear and shaft

- Check gears for excessive wear, chips or cracks.
- Check shaft for cracks, wear or bending.
- Check coupling sleeve for wear or damage.

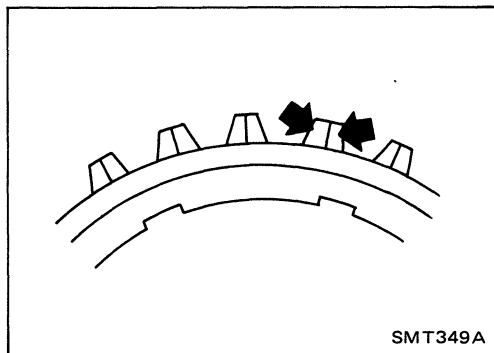

Baulk ring

- Check baulk ring for cracks or deformation.

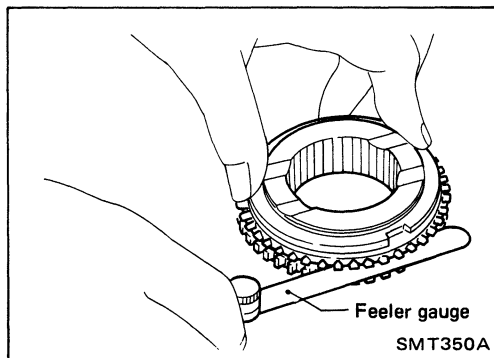

- Measure clearance between baulk ring and gear.

Baulk ring to gear clearance:

Unit: mm (in)

Standard	Wear limit
1.0 - 1.5 (0.039 - 0.059)	0.5 (0.020)

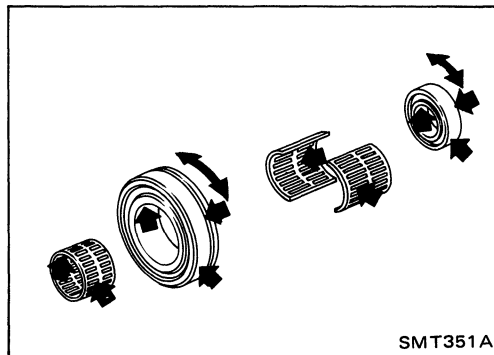

Bearing

- Make sure bearings roll freely and are free from noise, crack, pitting or wear.

REPAIR FOR COMPONENT PARTS

Mainshaft (Cont'd) ASSEMBLY

1. Press mainshaft front bearing onto mainshaft.
Pay special attention to its direction.

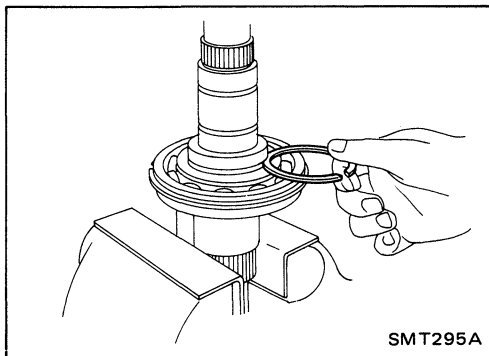
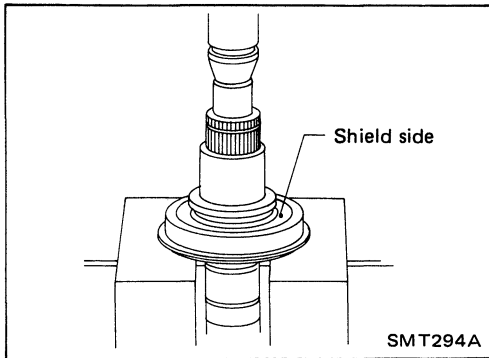

2. Install spacer.
3. Select snap ring with proper thickness and install it.
**Allowable clearance between snap ring and groove:
0 - 0.15 mm (0 - 0.0059 in)**

Available snap ring

Thickness mm (in)	Part number
3.1 (0.122)	33138-33G10
3.2 (0.126)	33138-33G11
3.3 (0.130)	33138-33G12
3.4 (0.134)	33138-33G13

4. Regarding to further procedures, refer to "ASSEMBLY".

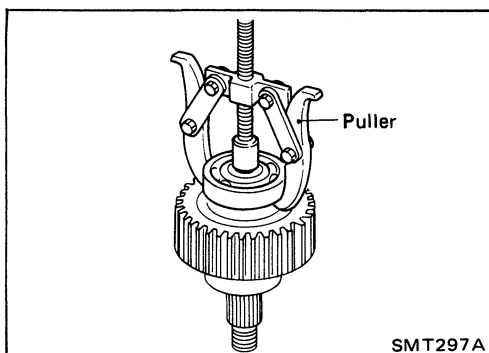
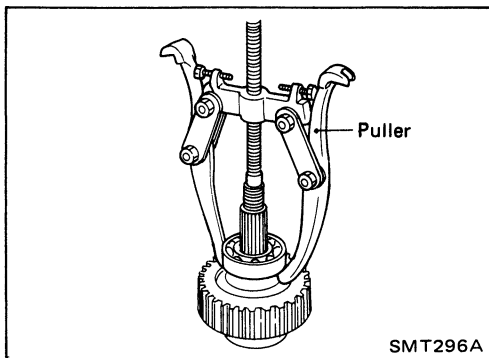

Front Drive Shaft DISASSEMBLY

- Front drive shaft front bearing
- Front drive shaft rear bearing

REPAIR FOR COMPONENT PARTS

Front Drive Shaft (Cont'd)

INSPECTION

Sprocket and shaft

- Check sprocket for excessive wear, chips or cracks.
- Check shaft for cracks or wear.

Bearing

- Make sure bearings roll freely and are free from noise, crack, pitting or wear.

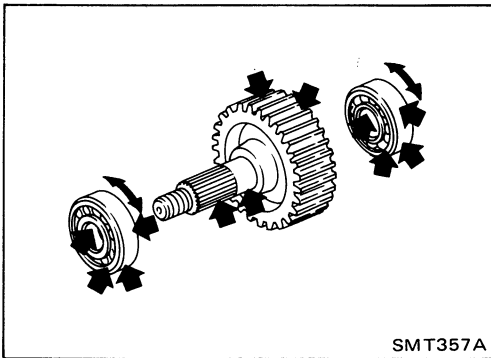

SMT357A

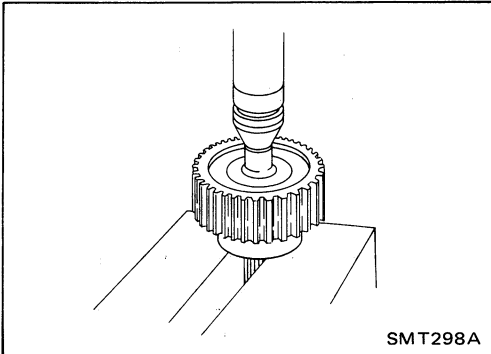

SMT298A

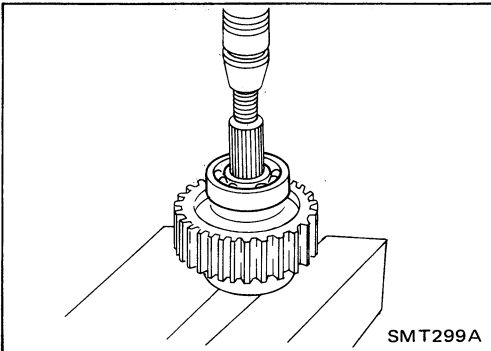

SMT299A

ASSEMBLY

- Press front drive shaft front bearing.

- Press front drive shaft rear bearing.

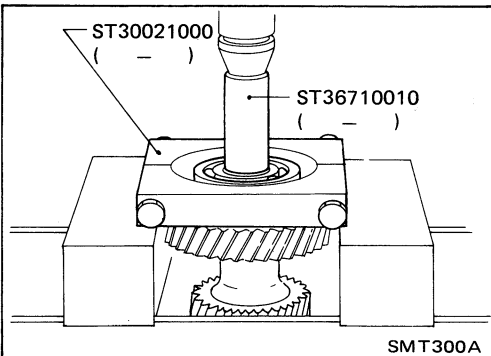

SMT300A

Counter Gear

DISASSEMBLY

1. Press out counter gear front bearing and then remove front sub-gear, spacer and dish spring.

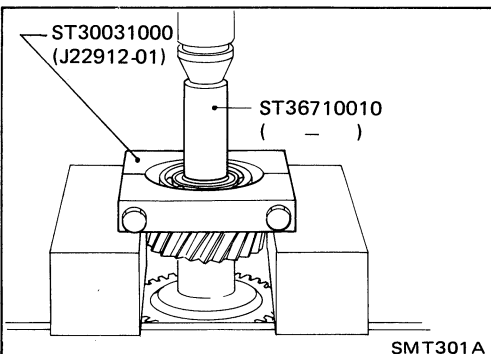

SMT301A

2. Press out counter gear rear bearing and then remove rear sub-gear, spacer and dish spring.

REPAIR FOR COMPONENT PARTS

Counter Gear (Cont'd)

INSPECTION

Gear and shaft

- Check gears for excessive wear, chips or cracks.
- Check shaft for cracks or wear.

Bearing

- Make sure bearings roll freely and are free from noise, crack, pitting or wear.

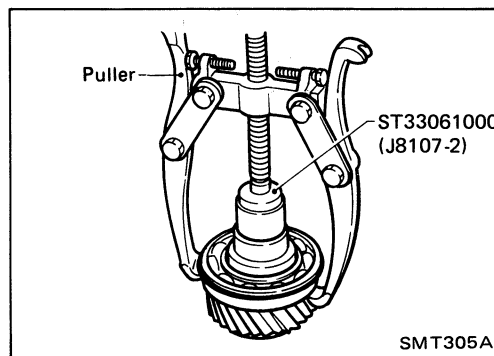
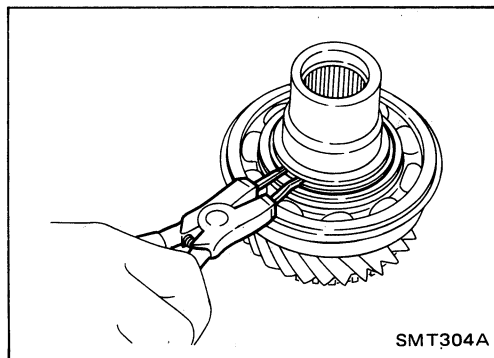
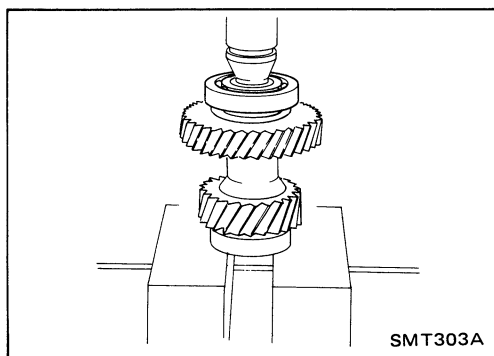
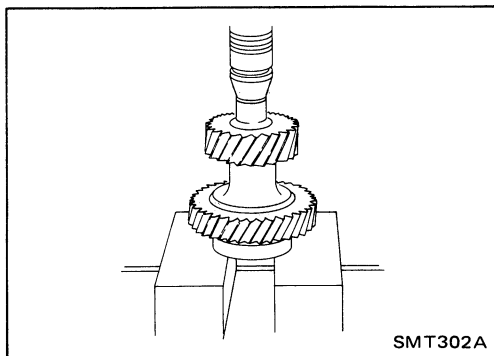
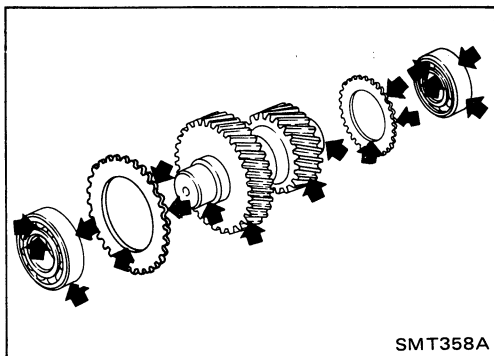

ASSEMBLY

1. Install front sub-gear, dish spring and spacer, and then press on counter gear front bearing.
2. Install rear sub-gear, dish spring and spacer, and then press on counter gear rear bearing.

Main Gear

DISASSEMBLY

Main gear bearing

1. Remove snap ring and spacer.
2. Pull out main gear bearing.

REPAIR FOR COMPONENT PARTS

Main Gear (Cont'd)

Plug

Always replace it with new one whenever it is removed.

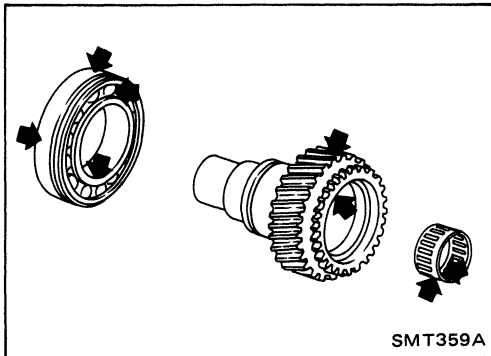
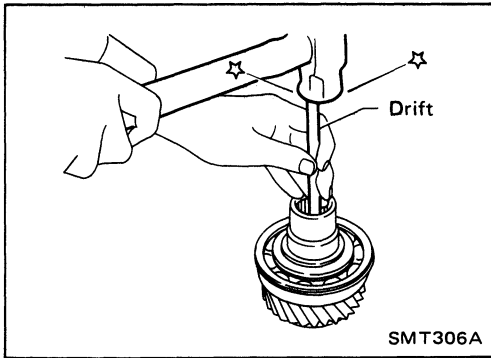

INSPECTION

Gear and shaft

- Check gears for excessive wear, chips or cracks.
- Check shaft for cracks or wear.

Bearing

- Make sure bearings roll freely and are free from noise, crack, pitting or wear.

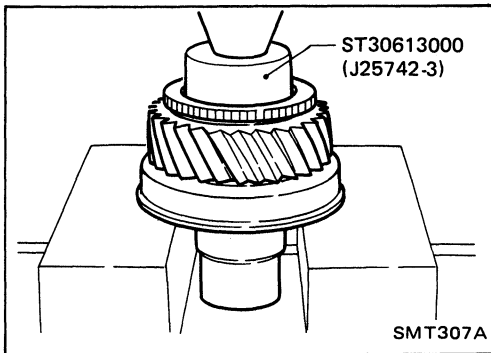

ASSEMBLY

Main gear bearing

1. Press on main gear bearing.
2. Install spacer.

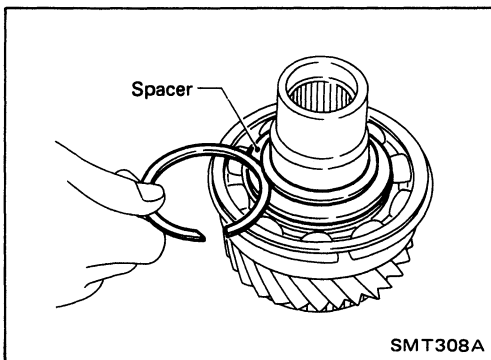

3. Select snap ring with proper thickness and install it.

Allowable clearance between snap ring and groove:

0 - 0.15 mm (0 - 0.0059 in)

Available snap ring

Thickness mm (in)	Part number
2.6 (0.102)	33114-33G00
2.7 (0.106)	33114-33G01
2.8 (0.110)	33114-33G02
2.9 (0.114)	33114-33G03

REPAIR FOR COMPONENT PARTS

Main Gear (Cont'd)

Plug

Apply sealant to plug and install it.

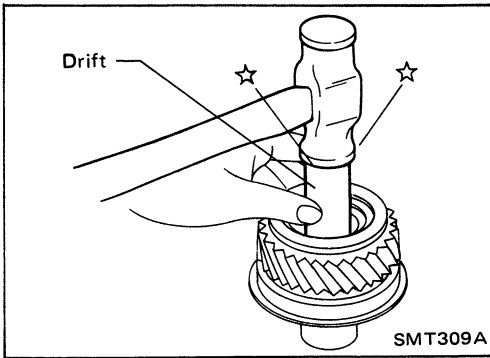

Front Case SHIFT SHAFT OIL SEAL

Removal

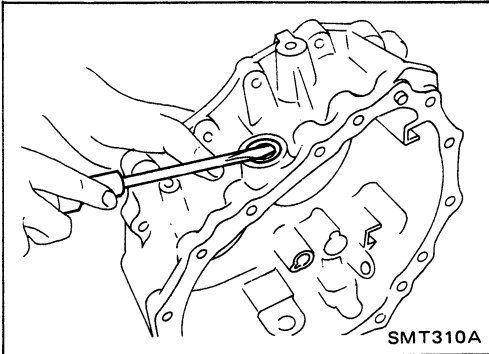

Installation

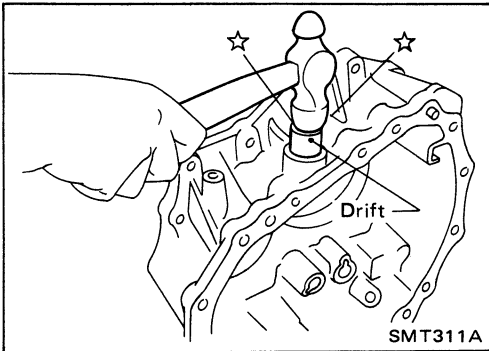

Front Case Cover COVER OIL SEAL

Removal

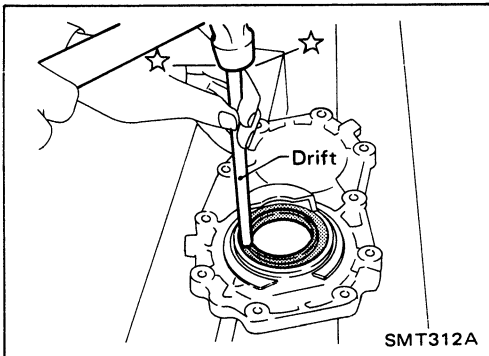

Installation

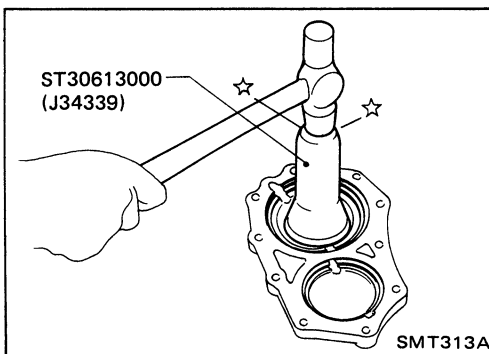

REPAIR FOR COMPONENT PARTS

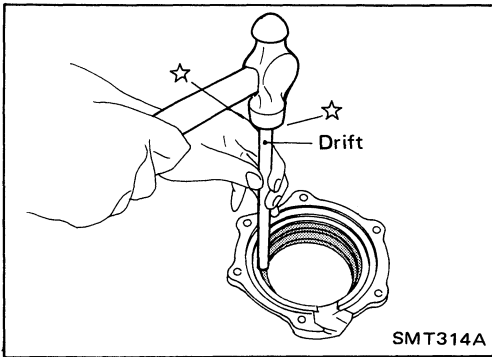

Bearing Retainer
OIL CATCHER
Removal

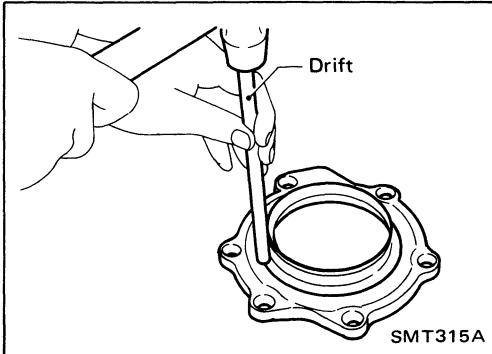

Installation

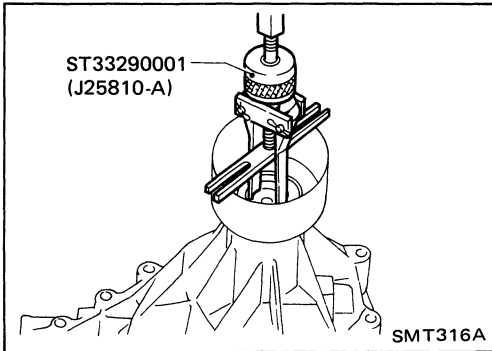

Rear Case
REAR OIL SEAL
Removal

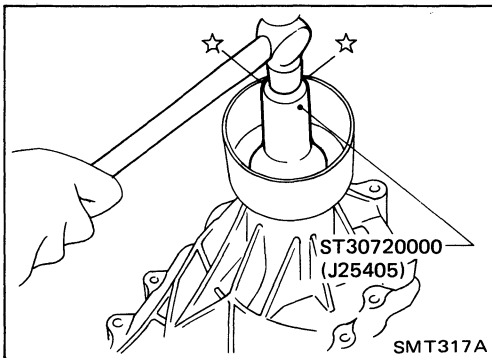

Installation

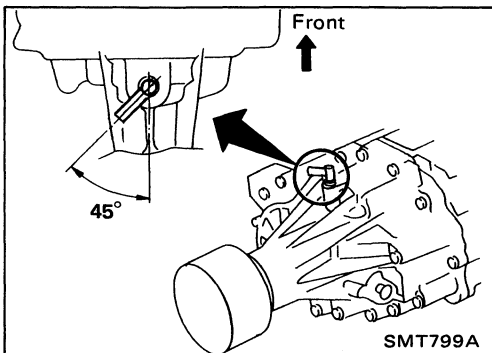

AIR BREATHER
Install as shown in illustration.

REPAIR FOR COMPONENT PARTS

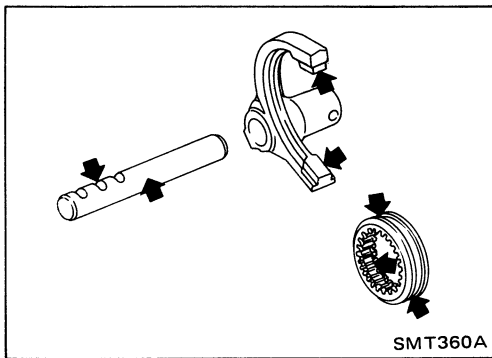

Shift Control Components INSPECTION

- Check contact surface and sliding surface for wear, scratches, projections or other faulty conditions.

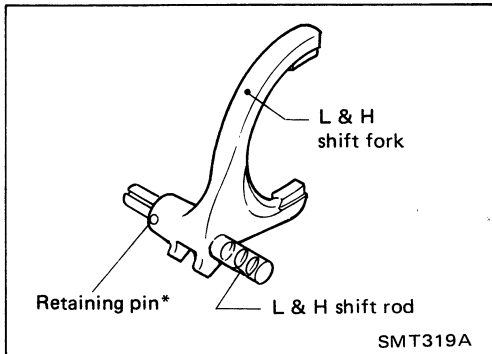

L & H SHIFT ROD & FORK

Assemble as shown in illustration.

* This pin is the same size as the one for 2-4 shift rod.

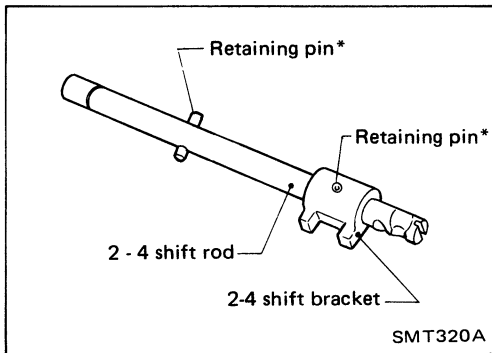

2-4 SHIFT ROD & FORK

Assemble as shown in illustration.

* These pins are the same size.

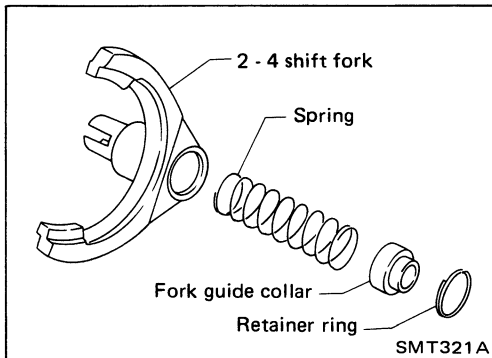

Pay special attention to the direction of fork guide collar.

ASSEMBLY

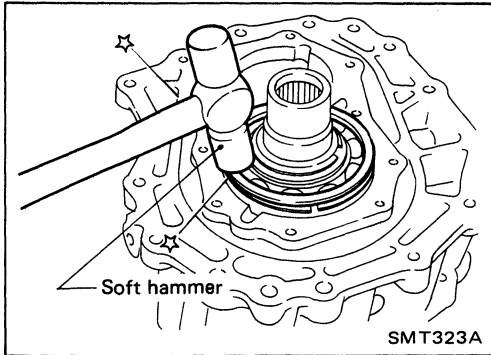

1. Assemble front case.
 - a. Install main gear assembly by tapping lightly.

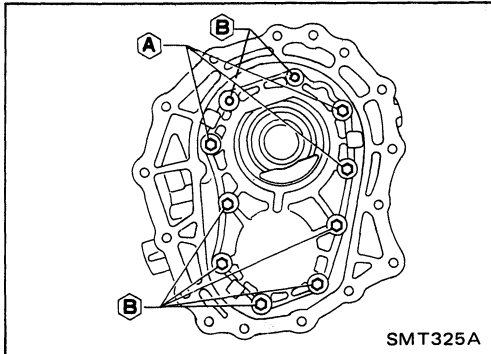

- b. Apply sealant to the mating surface and bolts of front case cover and install it on front case.
 - These ten bolts should be coated with sealant.
 - Tightening torque
 - Ⓐ : 16 - 21 N·m
(1.6 - 2.1 kg·m, 12 - 15 ft·lb)
 - Ⓑ : 19 - 24 N·m
(1.9 - 2.4 kg·m, 14 - 17 ft·lb)

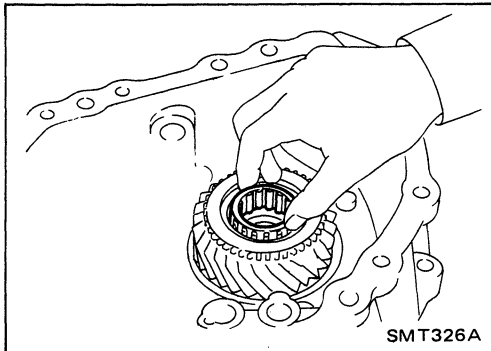

- c. Apply gear oil to needle bearing and install it into main gear.

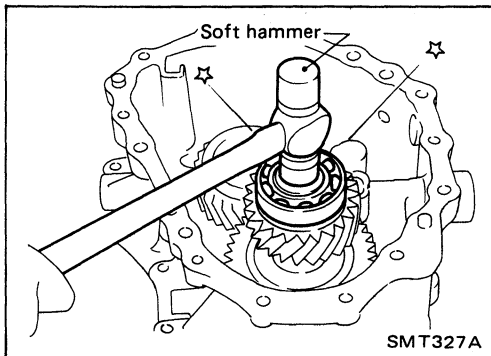

- d. Install counter gear assembly by tapping lightly.

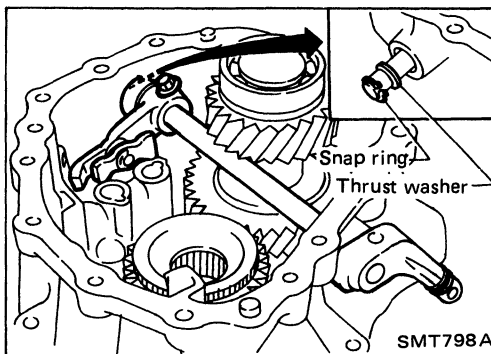

- e. Install cross shaft and inner shift lever.
When replacing cross shaft, outer shift lever or lock pin of outer shift lever, replace them as a set.

ASSEMBLY

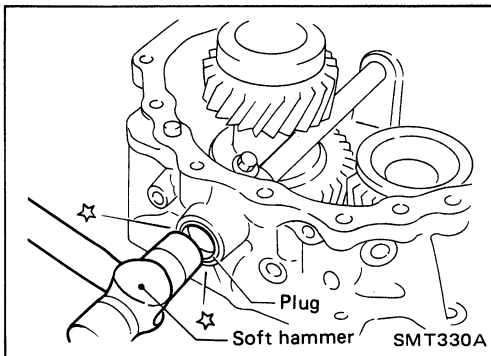

f. Apply sealant to plug and install it into front case.

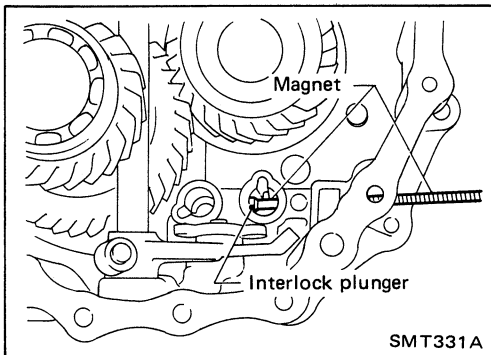

g. Insert interlock plunger into front case.

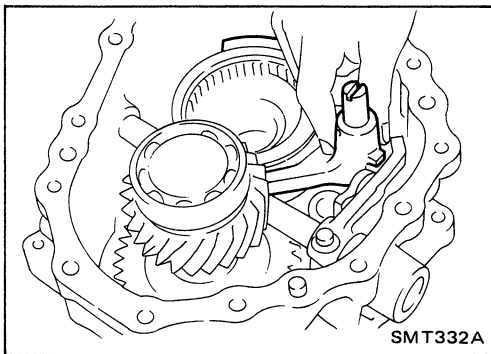

h. Install L & H shift rod and fork assembly with coupling sleeve.

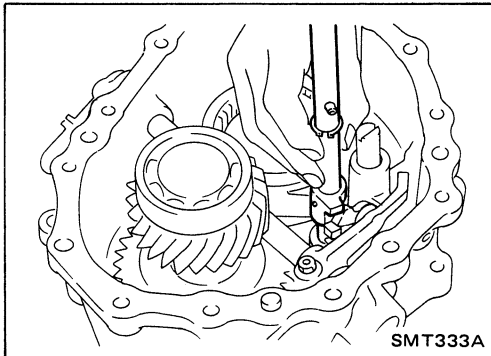

i. Install 2-4 shift rod.

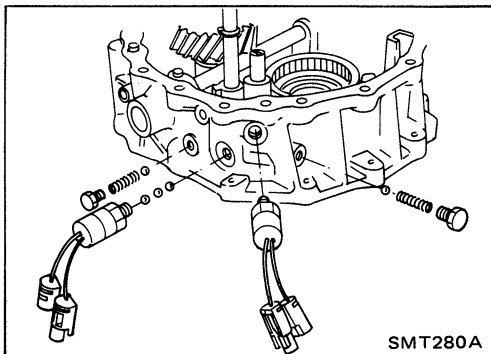

j. Install switches, check balls, check springs and plugs.
Apply sealant to switches and plugs.

ASSEMBLY

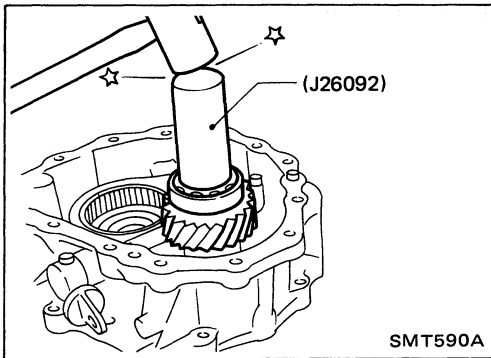

2. Select counter gear rear bearing shim.
- a. Seat counter gear assembly.

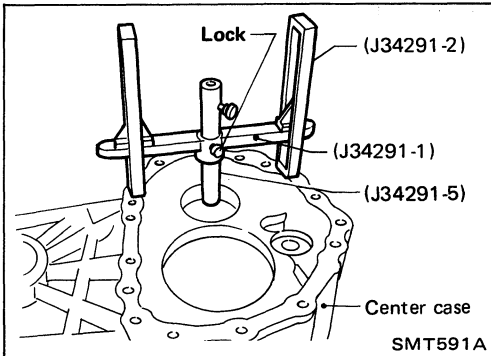

- b. Place J34291-1 (bridge), J34291-2 (legs) and J34291-5 (gauging cylinder) on machined surface of center case and allow gauging cylinder to rest on top outer portion of counter gear rear bearing. Lock gauging cylinder in place.

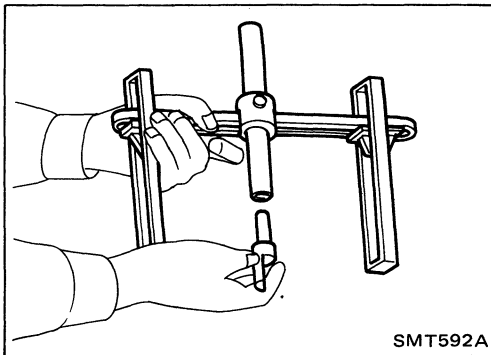

- c. Insert J34291-20 (gauging plunger) into J34291-5 (gauging cylinder).

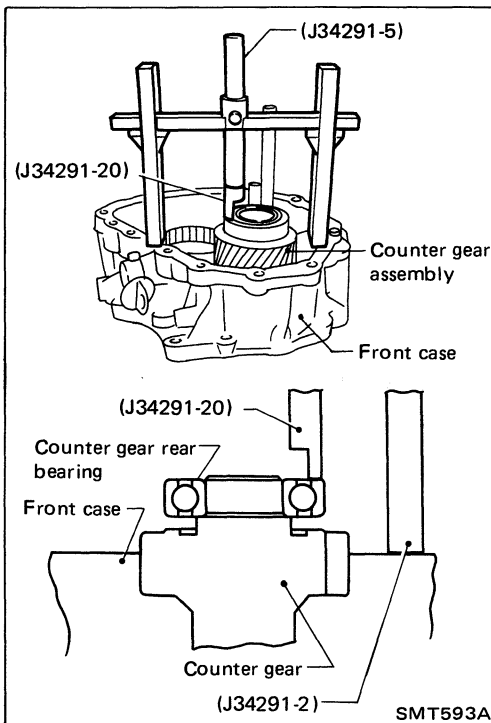

- d. Place bridge, legs, gauging cylinder and gauging plunger onto machined surface of front case assembly, and allow gauging plunger to drop until it contacts counter gear rear bearing mating surface.

ASSEMBLY

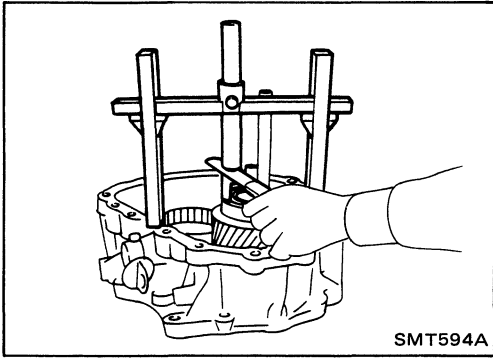

- e. Lock gauging plunger in place and use feeler gauge to measure gap between gauging cylinder and gauging plunger.

- f. Use measured distance and following chart to select correct shim.

Counter gear end play: 0 - 0.2 mm (0 - 0.008 in)
Counter gear rear bearing shim:

Thickness mm (in)	Part number
0.1 (0.004)	33112-C6900
0.2 (0.008)	33112-C6901
0.3 (0.012)	33112-C6902
0.4 (0.016)	33112-C6903
0.5 (0.020)	33112-33G00
0.6 (0.024)	33112-33G01

- g. Select counter gear rear bearing shim.

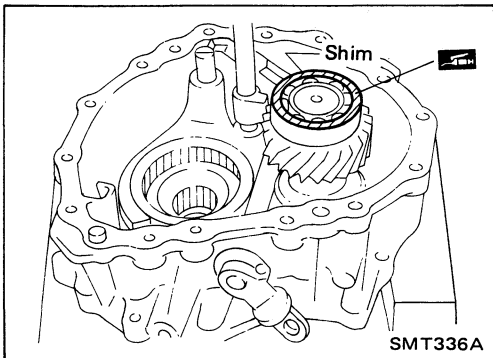

3. Place suitable shim on counter gear rear bearing with grease.
 4. Apply gear oil to each part in front case.

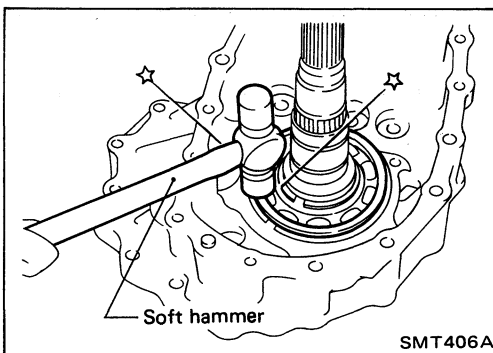

5. Assemble center case assembly.
 a. Install mainshaft on center case by tapping lightly.
Apply gear oil to mainshaft front bearing.

ASSEMBLY

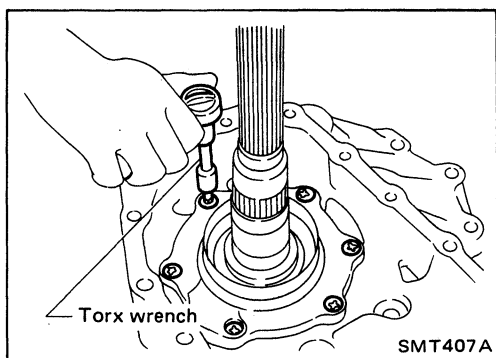

b. Install bearing retainer.

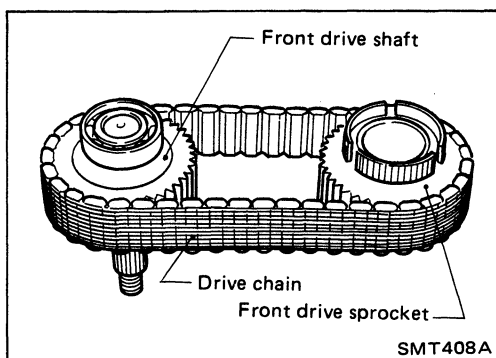

c. Put drive chain onto the front drive sprocket and front drive shaft, and then put them in center case.

Pay attention to direction of drive chain. (Refer to DISASSEMBLY.)

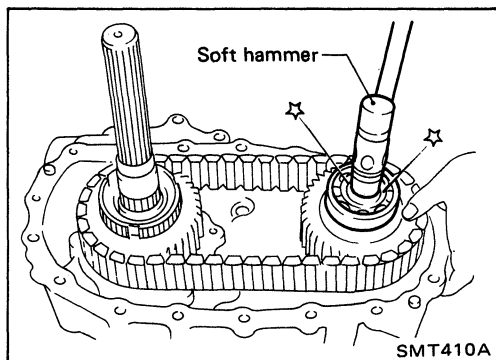
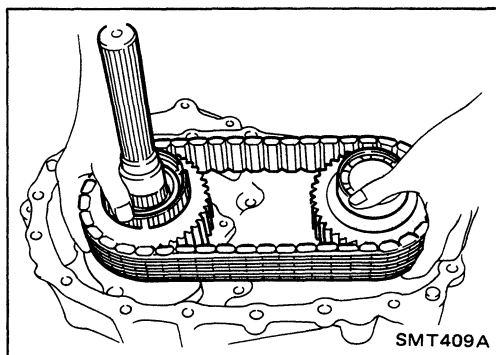

d. Install front drive shaft by tapping lightly. Make sure shafts are lined up in the case.

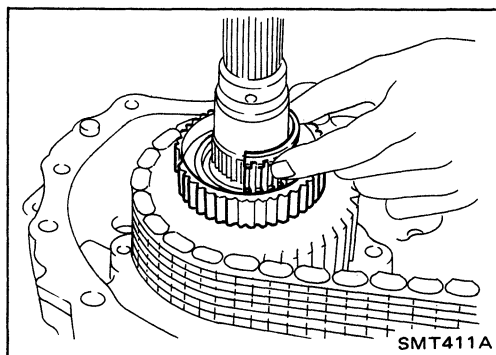

e. Apply gear oil to needle bearings and install them into front drive sprocket.

These needle bearings will be installed more easily if front drive sprocket is rotated while installing them.

ASSEMBLY

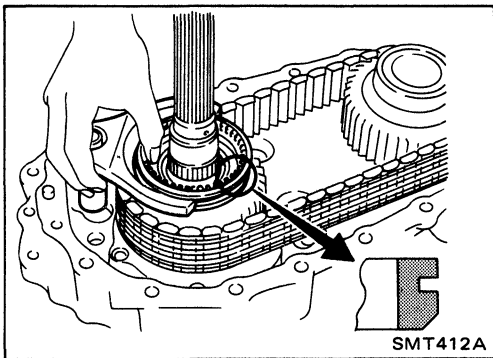

- f. Install 2-4 coupling sleeve with 2-4 shift fork.
Pay special attention to direction of coupling sleeve.

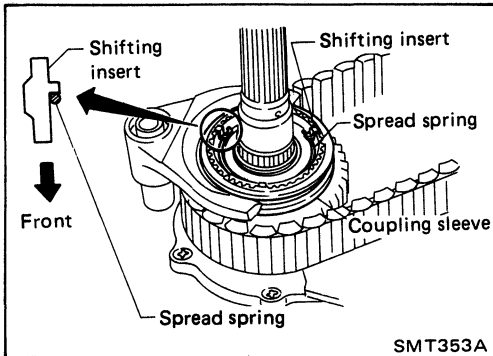

- g. Install shifting inserts and spread spring.
Pay special attention to direction of shifting inserts.

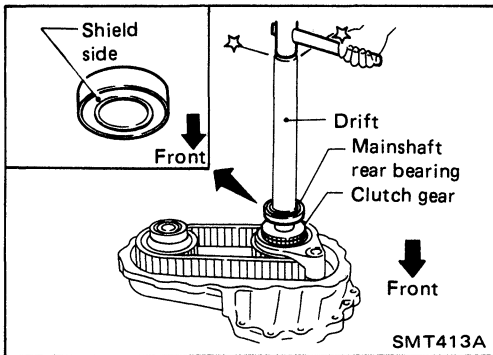

- h. Install baulk ring and then install clutch gear and mainshaft rear bearing.
Place wooden block under mainshaft in order to protect mainshaft front bearing.

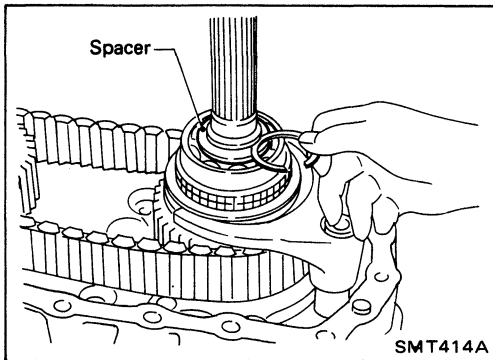

- i. Install spacer.
j. Select snap ring with proper thickness and install it.
Allowable clearance between snap ring and groove:
0 - 0.15 mm (0 - 0.0059 in)

Available snap ring

Thickness mm (in)	Part number
1.8 (0.071)	33138-33G20
1.9 (0.075)	33138-33G21
2.0 (0.079)	33138-33G22
2.1 (0.083)	33138-33G23
2.2 (0.087)	33138-33G24

ASSEMBLY

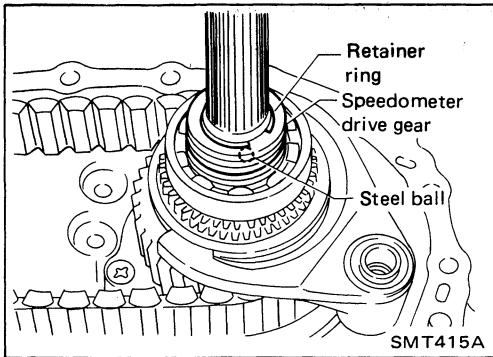

- k. Install steel ball, speedometer drive gear and retainer ring.
Steel ball is the smallest of check balls for this unit.

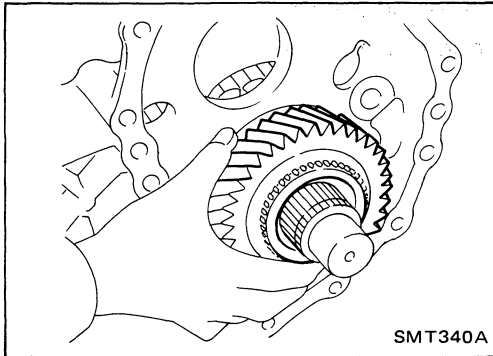

- l. Install low gear and its bearing to mainshaft.
Apply gear oil to needle bearing.

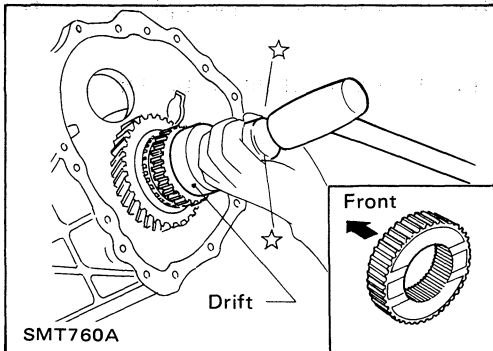

- m. Install L & H hub and snap ring to mainshaft.
Pay special attention to direction of L & H hub.

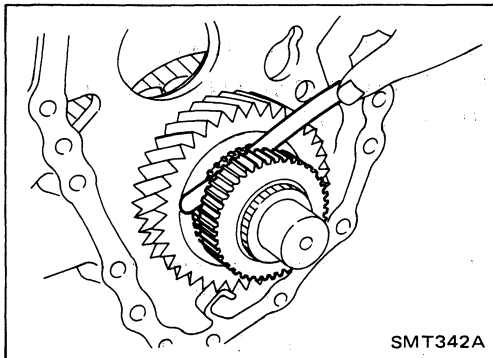

- n. Measure end play of low gear.
Standard: 0.2 - 0.35 mm (0.0079 - 0.0138 in)

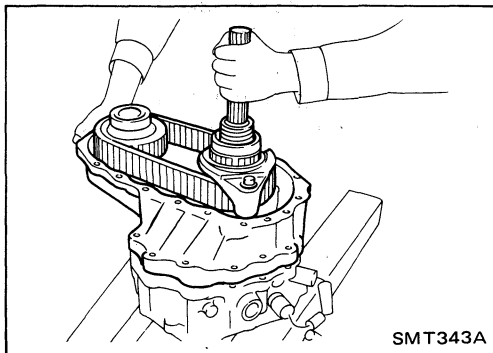

6. Apply sealant to mating surface and put center case assembly onto front case and tighten bolts.

ASSEMBLY

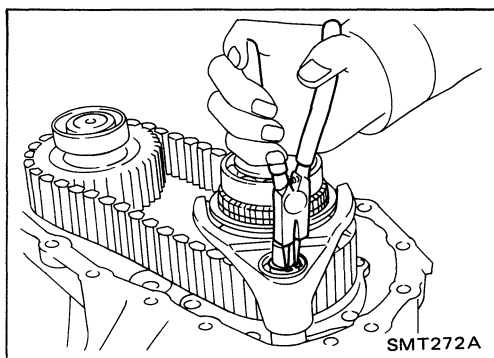

7. Install snap ring to 2-4 shift rod.

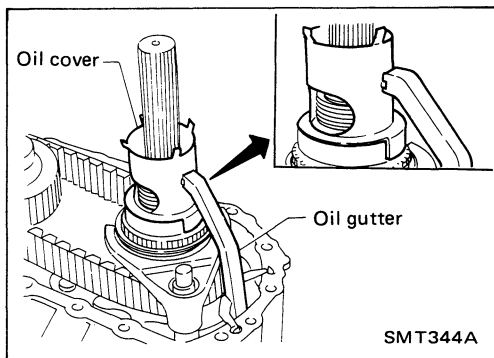

8. Install oil gutter and oil cover.

9. Apply gear oil to each part in center case.

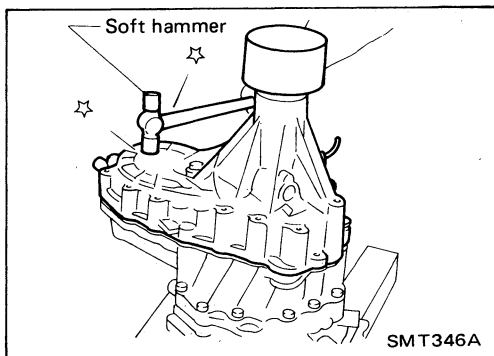

10. Apply sealant to mating surface and install rear case on center case.

SERVICE DATA AND SPECIFICATIONS (S.D.S.)

General Specifications

Transfer model		TX10	
Gear ratio	High	1.000	
	Low	2.020	
Number of teeth	Main gear	29	
	Low gear	37	
	Counter gear	High	38
		Low	24
	Front drive sprocket	41	
	Front drive shaft	41	
Oil capacity	liters (US qt, Imp qt)	2.2 (2-3/8, 2)	

Inspection and Adjustment

GEAR END PLAY

	mm (in)
Front drive sprocket	0.2 - 0.35 (0.0079 - 0.0138)
Low gear	0.2 - 0.35 (0.0079 - 0.0138)
Counter gear	0 - 0.2 (0 - 0.008)

CLEARANCE BETWEEN BAULK RING AND CLUTCH GEAR

mm (in)	
Standard	Wear limit
1.0 - 1.5 (0.039 - 0.059)	0.5 (0.020)

AVAILABLE SNAP RING

Mainshaft front bearing

Allowable clearance		0 - 0.15 mm (0 - 0.0059 in)
Thickness mm (in)	Part number	
3.1 (0.122)	33138-33G10	
3.2 (0.126)	33138-33G11	
3.3 (0.130)	33138-33G12	
3.4 (0.134)	33138-33G13	

Mainshaft rear bearing

Allowable clearance		0 - 0.15 mm (0 - 0.0059 in)
Thickness mm (in)	Part number	
1.8 (0.071)	33138-33G20	
1.9 (0.075)	33138-33G21	
2.0 (0.079)	33138-33G22	
2.1 (0.083)	33138-33G23	
2.2 (0.087)	33138-33G24	

Main gear bearing

Allowable clearance		0 - 0.15 mm (0 - 0.0059 in)
Thickness mm (in)	Part number	
2.6 (0.102)	33114-33G00	
2.7 (0.106)	33114-33G01	
2.8 (0.110)	33114-33G02	
2.9 (0.114)	33114-33G03	

SERVICE DATA AND SPECIFICATIONS (S.D.S.)

Inspection and Adjustment (Cont'd)

AVAILABLE SHIM

Counter gear rear bearing

Thickness mm (in)	Part number
0.1 (0.004)	33112-C6900
0.2 (0.008)	33112-C6901
0.3 (0.012)	33112-C6902
0.4 (0.016)	33112-C6903
0.5 (0.020)	33112-33G00
0.6 (0.024)	33112-33G01

Tightening Torque

Unit	N-m	kg-m	ft-lb
Transfer installation			
Transfer fixing bolt	31 - 41	3.2 - 4.2	23 - 30
Second crossmember fixing bolt	59 - 78	6.0 - 8.0	43 - 58
Transfer control			
Guide plate fixing bolt	8 - 11	0.8 - 1.1	5.8 - 8.0
Control lever bracket fixing bolt	16 - 21	1.6 - 2.1	12 - 15
Transfer control lever to outer shift lever	25 - 30	2.5 - 3.1	18 - 22
Transfer unit			
Rear case to center case	26 - 36	2.7 - 3.7	20 - 27
Center case to front case	26 - 36	2.7 - 3.7	20 - 27
Front case cover	16 - 21 19 - 24	1.6 - 2.1 1.9 - 2.4	12 - 15 14 - 17
Breather cover fixing bolt	4 - 5	0.4 - 0.5	2.9 - 3.6
Bearing retainer	16 - 21	1.6 - 2.1	12 - 15
Companion flange nut	226 - 324	23 - 33	166 - 239
Check plug	19 - 25	1.9 - 2.5	14 - 18
Cross shaft lock pin	9 - 12	0.9 - 1.2	6.5 - 8.7
4WD switch	15 - 20	1.5 - 2.0	11 - 14
Neutral switch	15 - 20	1.5 - 2.0	11 - 14
Drain plug	25 - 34	2.5 - 3.5	18 - 25
Filler plug	25 - 34	2.5 - 3.5	18 - 25
Speedometer sleeve	3 - 4	0.3 - 0.4	2.2 - 2.9
Underguard fixing bolt			
(M8 bolt)	16 - 21	1.6 - 2.1	12 - 15
(M10 bolt)	26 - 36	2.7 - 3.7	20 - 27

PROPELLER SHAFT & DIFFERENTIAL CARRIER

SECTION **PD**

CONTENTS

PREPARATION	PD- 3
PROPELLER SHAFT	PD- 8
ON-VEHICLE SERVICE (Final Drive)	PD- 15
REMOVAL AND INSTALLATION (Final Drive: Model R180A and R200A)	PD- 17
REMOVAL AND INSTALLATION (Final Drive: Model H190A and H233B)	PD- 18
REMOVAL AND INSTALLATION (Final Drive: Model C200)	PD- 19
FRONT FINAL DRIVE (Model R180A)	PD- 20
DISASSEMBLY (Model R180A)	PD- 21
INSPECTION (Model R180A)	PD- 26
ADJUSTMENT (Model R180A)	PD- 27
ASSEMBLY (Model R180A)	PD- 34
FRONT FINAL DRIVE (Model R200A)	PD- 40
DISASSEMBLY (Model R200A)	PD- 41
INSPECTION (Model R200A)	PD- 47
ADJUSTMENT (Model R200A)	PD- 48
ASSEMBLY (Model R200A)	PD- 56
REAR FINAL DRIVE (Model H190A)	PD- 63
DISASSEMBLY (Model H190A)	PD- 64
INSPECTION (Model H190A)	PD- 68
ADJUSTMENT (Model H190A)	PD- 69
ASSEMBLY (Model H190A)	PD- 76
REAR FINAL DRIVE (Model C200)	PD- 81
DISASSEMBLY (Model C200)	PD- 82
INSPECTION (Model C200)	PD- 86
ADJUSTMENT (Model C200)	PD- 87
ASSEMBLY (Model C200)	PD- 94

PD

Contents (Cont'd)



REAR FINAL DRIVE (Model H233B)	PD-100
DISASSEMBLY (Model H233B)	PD-102
INSPECTION (Model H233B)	PD-107
LIMITED SLIP DIFFERENTIAL (For H233B)	PD-108
ADJUSTMENT (Model H233B)	PD-115
ASSEMBLY (Model H233B)	PD-121
SERVICE DATA AND SPECIFICATION (S.D.S.)	PD-127

PREPARATION

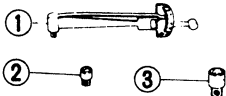
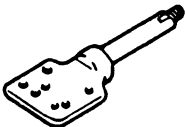
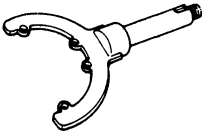
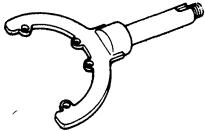



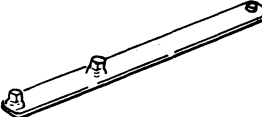

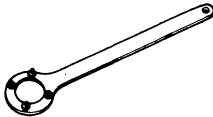
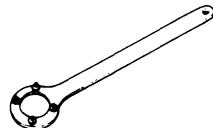
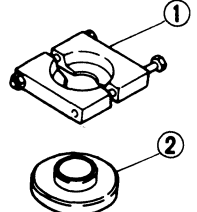
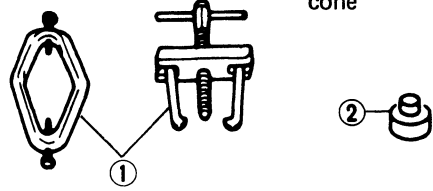
SPECIAL SERVICE TOOLS

Tool number (Kent-Moore No.) Tool name	Description	Unit application				
		R180A	R200A	H190A	C200	H233B
ST3127S000 (See J25765-A) Preload gauge ① GG91030000 (J25765) Torque wrench ② HT62940000 (-) Socket adapter ③ HT62900000 (-) Socket adapter	Measuring pinion bearing preload and total preload 	X	X	X	X	X
KV38100800 (-) Differential attachment Equivalent tool (J25604-01)	Mounting final drive 	X	X	-	-	-
ST06310000 (-) Differential attachment Equivalent tool (J25602-01)	Mounting final drive 	-	-	X	-	-
ST06340000 (-) Differential attachment Equivalent tool (J24310)	Mounting final drive 	-	-	-	-	X

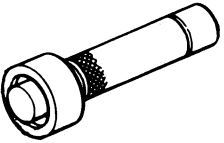
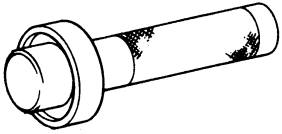
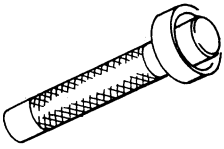
PREPARATION

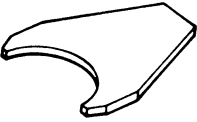
Tool number (Kent-Moore No.) Tool name	Description	Unit application				
		R180A	R200A	H190A	C200	H233B
ST32580000 (J34312) Differential side bearing adjusting nut wrench	 Adjusting side bearing preload and backlash (ring gear-drive pinion)	-	-	-	-	X
ST33290001 (J25810-A) Side bearing outer race puller	 Removing side bearing outer race and side oil seal	X	-	-	-	-
ST38060002 (J34311) Drive pinion flange wrench	 Removing and installing propeller shaft lock nut, and drive pinion lock nut	X	X	X	X (2WD)	-
KV38104700 (J34311) Drive pinion flange wrench	 Removing and installing propeller shaft lock nut, and drive pinion lock nut	-	-	-	X (4WD)	X
ST3090S000 (-) Drive pinion rear inner race puller set ① ST30031000 (J22912-01) Puller ② ST30901000 (-) Base Equivalent tool (J26010-01)	 Removing and installing drive pinion rear inner cone	X	X	X	X	X
ST3306S001 Differential side bearing puller set ① ST33051001 (-) Body Equivalent tool (J22888) ② ST33061000 (J8107-2) Adapter	 Removing and installing differential side bearing inner cone	X	X	X	X	X



PREPARATION

Tool number (Kent-Moore No.) Tool name	Description	Unit application				
		R180A	R200A	H190A	C200	H233B
ST33230000 (J25805-01) Differential side bearing drift	 Installing side bearing inner cone	X	—	X	X	—
KV38100300 (J25523) Differential side bearing drift	 Installing side bearing inner cone	—	X	—	—	—
ST33190000 (—) Differential side bearing drift Equivalent tool (J25523)	 Installing side bearing inner cone	—	—	—	—	X
ST33081000 (—) Side bearing puller adapter	 Installing side bearing inner cone	—	—	—	—	X
KV38100600 (J25267) Side bearing spacer drift	 Installing side bearing spacer	—	X	—	X	—
ST30611000 (J25742-1) Drift	 Installing pinion rear bearing outer race	X	X	X	X	X
ST30621000 (J25742-5) Drift	 Installing pinion rear bearing outer race	X	X	X	X	X
ST30701000 (J25742-2) Drift	 Installing pinion front bearing outer race	X	—	—	—	—
ST30613000 (J25742-3) Drift	 Installing pinion front bearing outer race	—	X	X	X	X

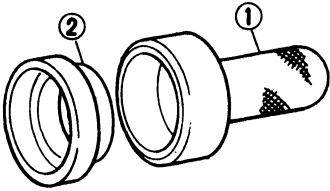
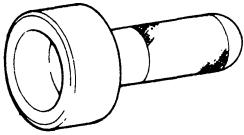
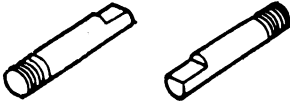
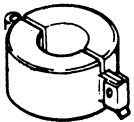
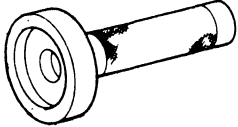
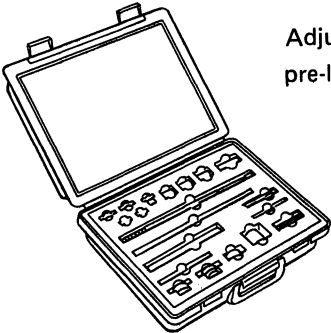
PREPARATION

Tool number (Kent-Moore No.) Tool name	Description	Unit application				
		R180A	R200A	H190A	C200	H233B
KV381025S0 (-) Oil seal fitting tool ① ST30720000 (-) Drift bar Equivalent tool (J25405) ② KV38102510 (-) Drift	Installing front oil seal 	X	-	X	-	X
KV38100500 (-) Gear carrier front oil seal drift Equivalent tool (J25273)	Installing front oil seal 	-	X	-	X	-
ST33720000 (J25817) Differential side retainer guide	Installing side retainer 	X	-	-	-	-
ST33270000 (J25809) Side oil seal drift	Installing side oil seal 	X	-	-	-	-
KV38100200 (J26233) Gear carrier side oil seal drift	Installing side oil seal 	-	X	-	-	-
(J34309) Differential shim selector	Adjusting bearing pre-load and gear height 	X	X	X	X	X

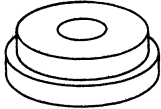
PREPARATION

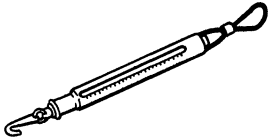
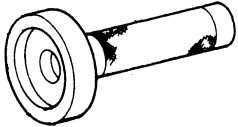
Tool number (Kent-Moore No.) Tool name	Description	Unit application				
		R180A	R200A	H190A	C200	H233B
(J25269-4) Side bearing discs (2 Req'd)	 Selecting pinion height adjusting washer	X	X	-	X	-
(J25269-18) Side bearing discs (2 Req'd)	 Selecting pinion height adjusting washer	-	-	X	-	X
(J8129) Spring gauge	 Measuring carrier turning torque	X	X	X	X	X
(J35764) Gear carrier side oil seal drift	 Installing side oil seal	X	-	-	-	-

PROPELLER SHAFT

Front propeller shaft (Model 2F63H and 2F71H)

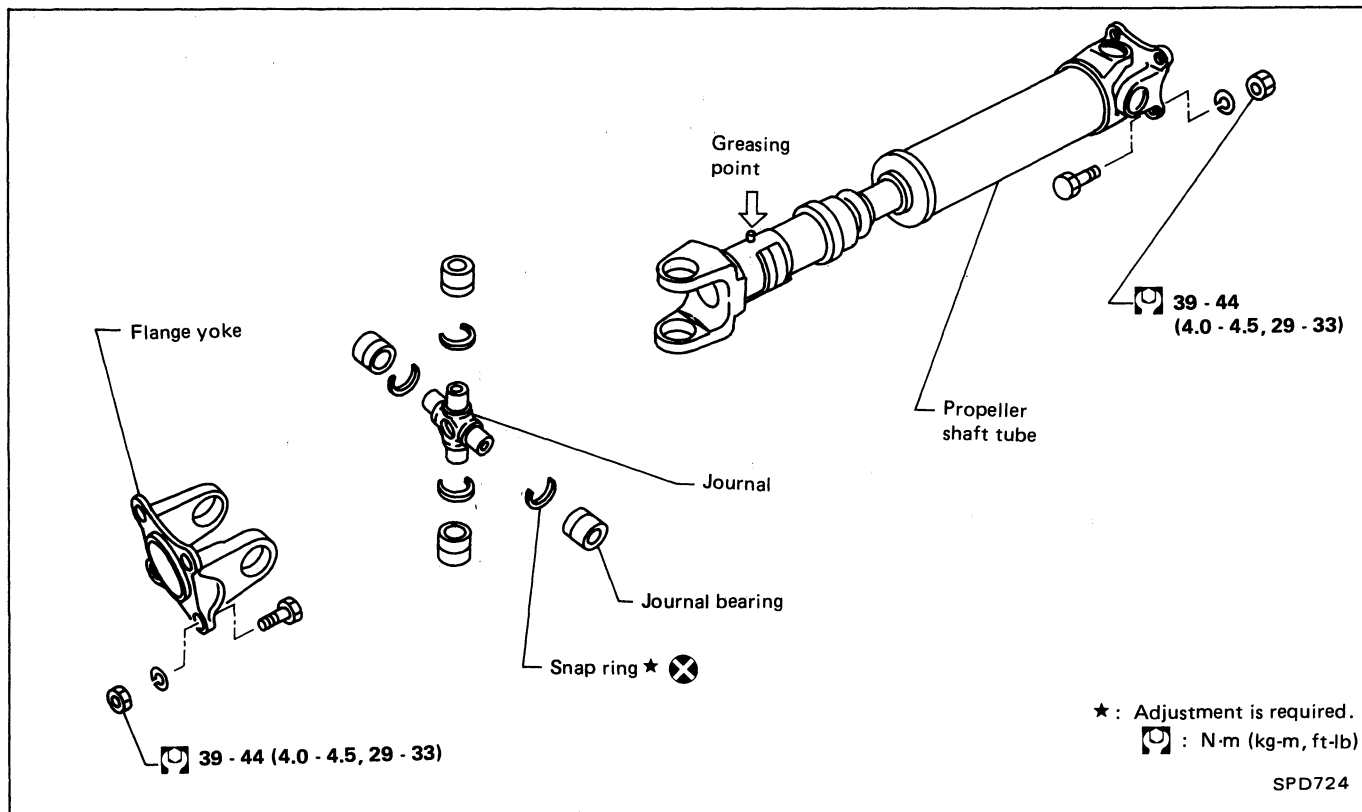

Rear propeller shaft (Model 2S71H and 2S80B)

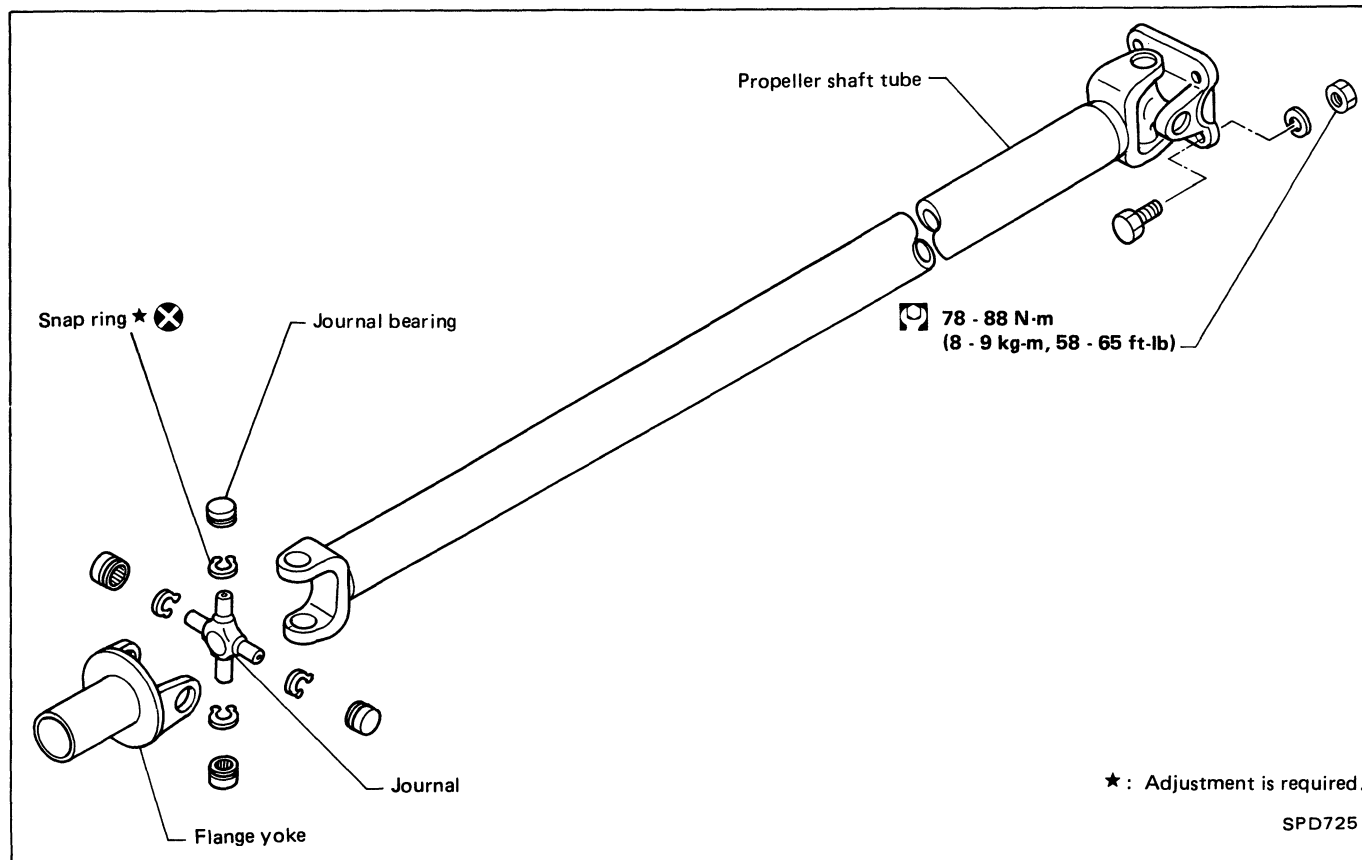

PROPELLER SHAFT

Rear propeller shaft (Model 3S71H and 3S80B)

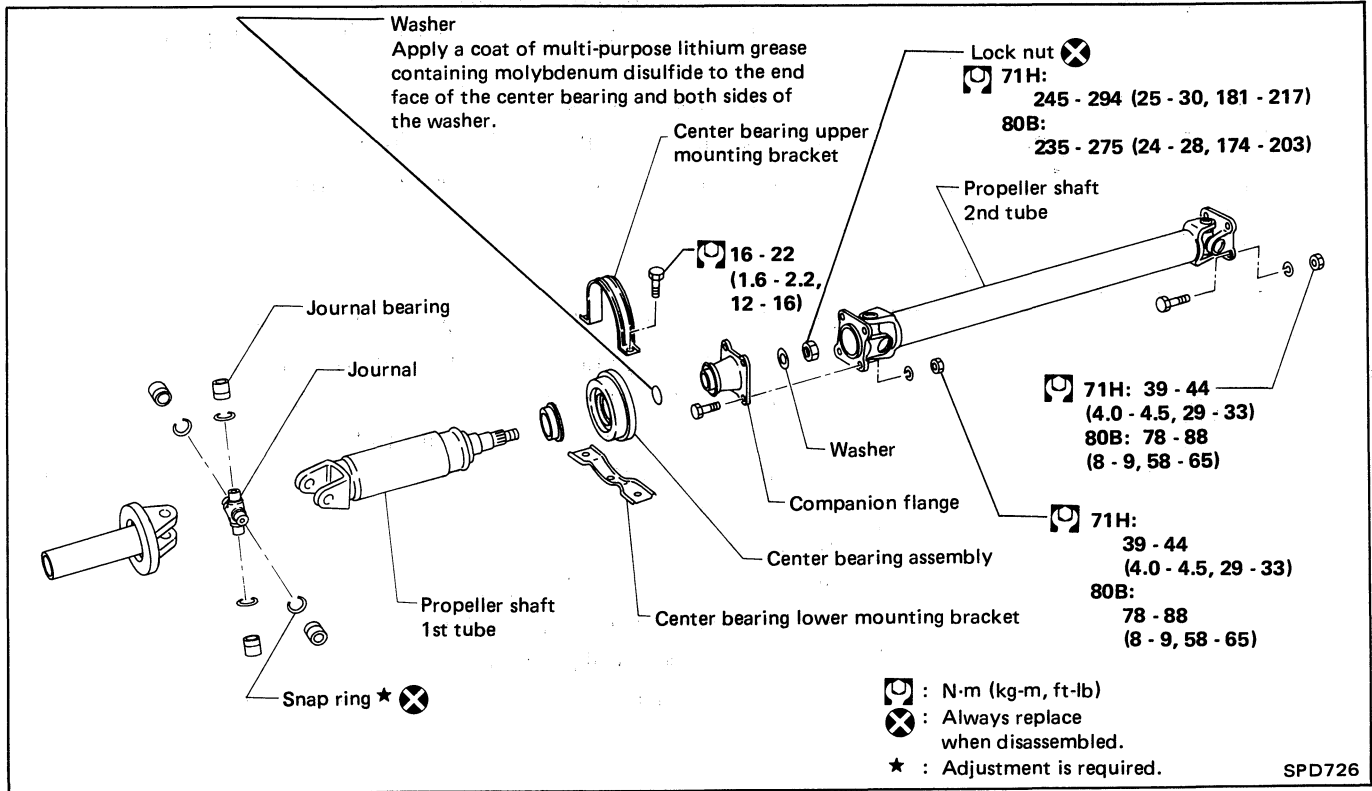

Rear propeller shaft (Model 3S63A)

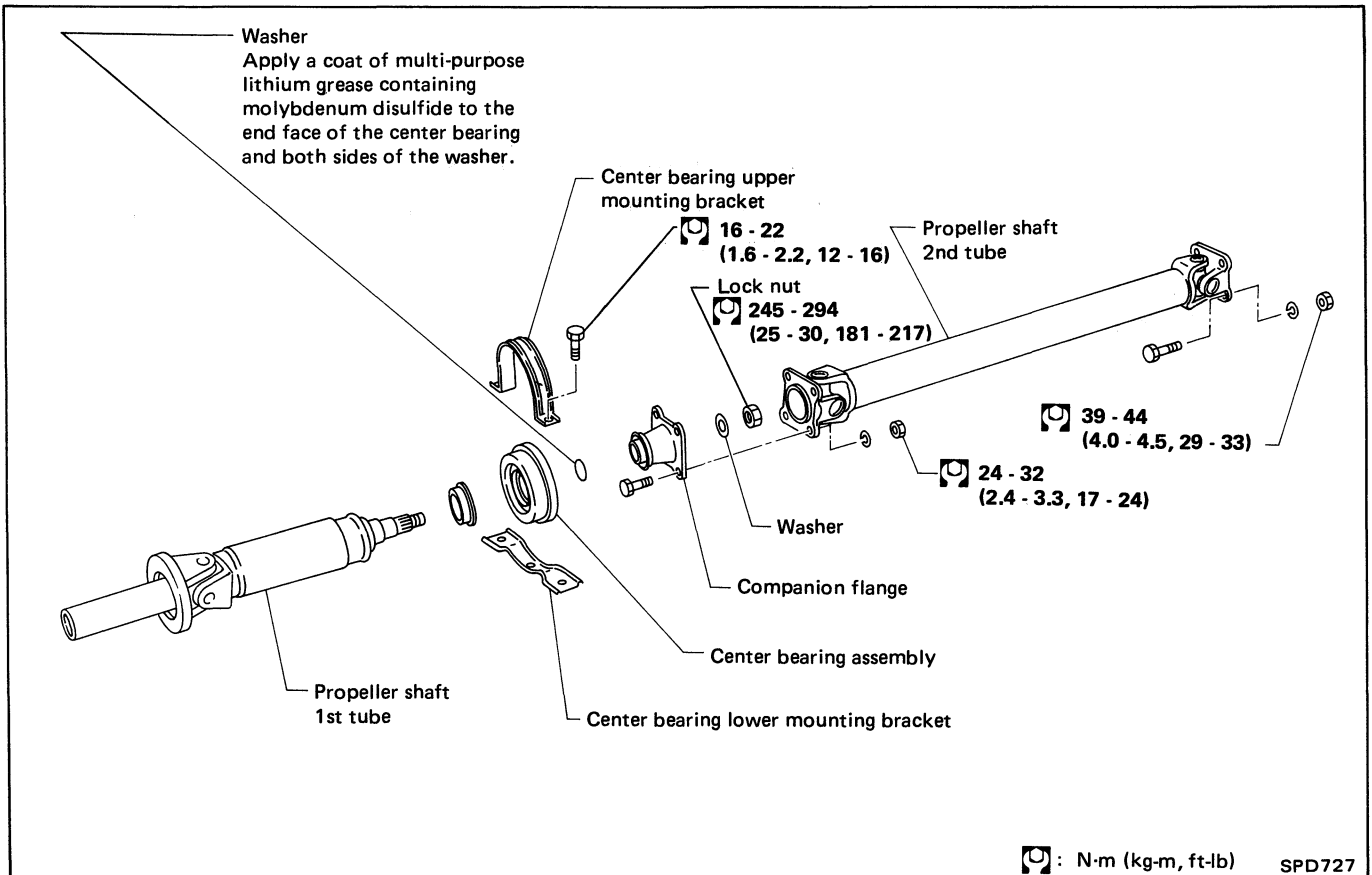

PROPELLER SHAFT

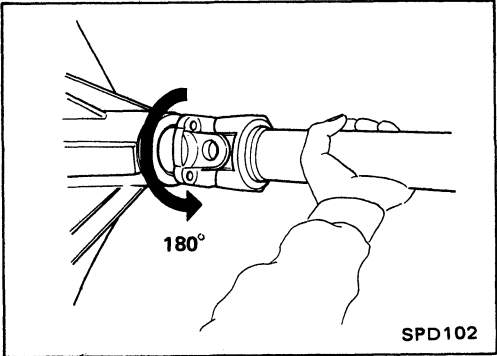
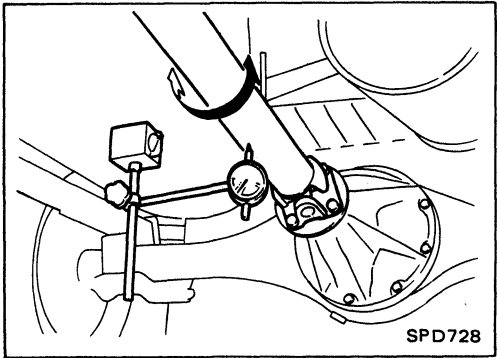

On-vehicle Service

PROPELLER SHAFT VIBRATION

If vibration is present at high speed, inspect propeller shaft run-out first.

1. Raise rear wheels.
2. Measure propeller shaft runout at several points by rotating final drive companion flange with hands.

3. If runout exceeds specifications, disconnect propeller shaft at final drive companion flange; then rotate companion flange 180 degrees and reconnect propeller shaft.

Runout limit: 0.6 mm (0.024 in)

4. Check runout again. If runout still exceeds specifications, replace propeller shaft assembly.
5. Perform road test.

APPEARANCE CHECKING

- Inspect propeller shaft tube surface for dents or cracks. If damaged, replace propeller shaft assembly.
- If center bearing is noisy or damaged, replace center bearing.

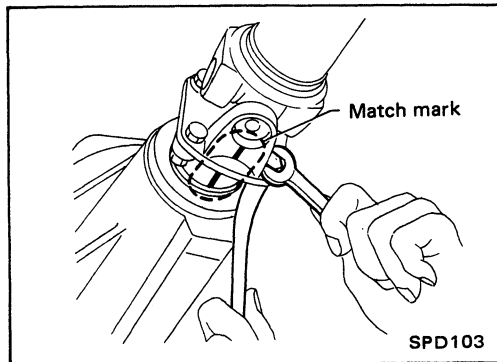

Removal and Installation

- Put match marks on flanges and separate propeller shaft from final drive.

PROPELLER SHAFT

Removal and Installation (Cont'd)

- Draw out propeller shaft from transmission and plug up rear end of transmission rear extension housing.

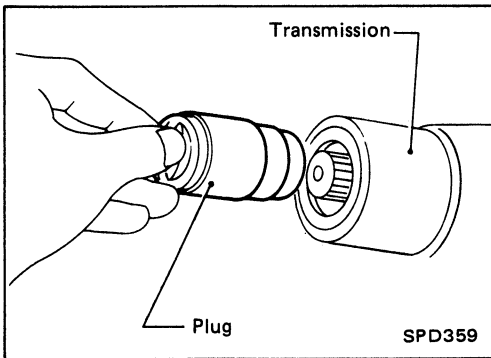

Inspection

- Inspect propeller shaft runout. If runout exceeds specifications, replace propeller shaft assembly.

Runout limit: 0.6 mm (0.024 in)

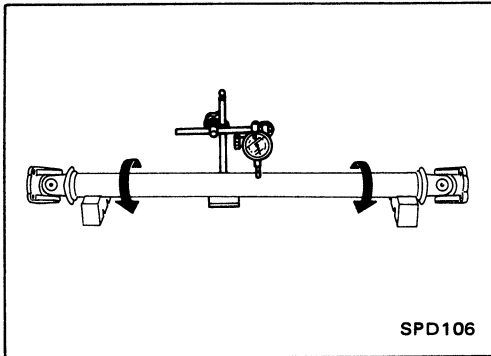

- Inspect journal axial play. If the play exceeds specifications, replace propeller shaft assembly.

Journal axial play:

63A 0 mm (0 in)

63H, 71H, 80B 0.02 mm (0.0008 in) or less

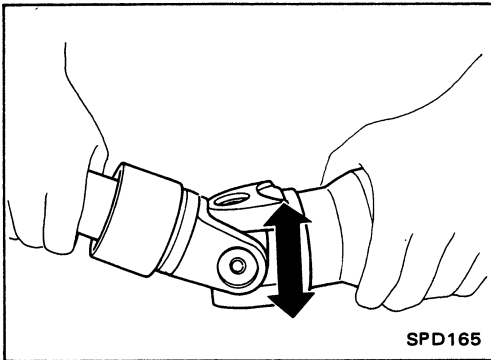

Disassembly

CENTER BEARING

1. Put match marks on flanges, and separate 2nd tube from 1st tube.

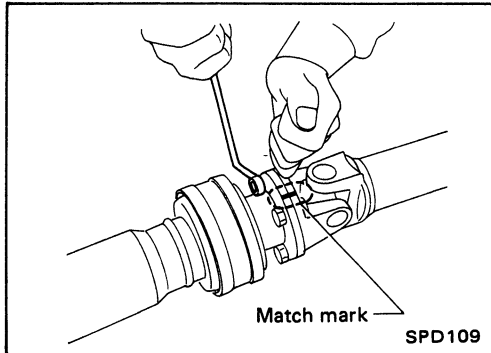

2. Put match marks on the flange and shaft.

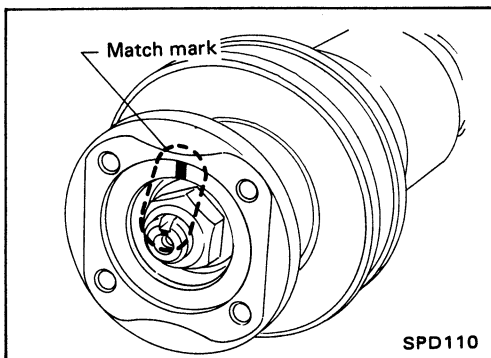

PROPELLER SHAFT

Disassembly (Cont'd)

3. Remove locking nut with Tool.

Tool number:

R180A, R200A, H190A, C200

(2WD except Van and Wagon)

ST38060002 (J34311)

C200 (Van and Wagon), H233B

KV38104700 (J34311)

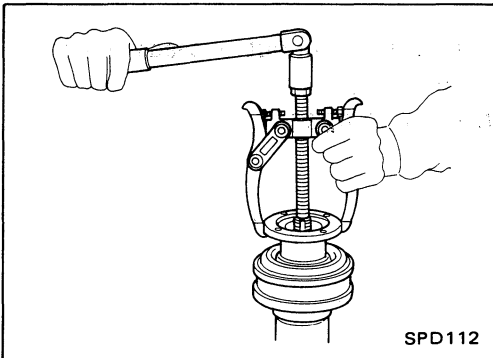
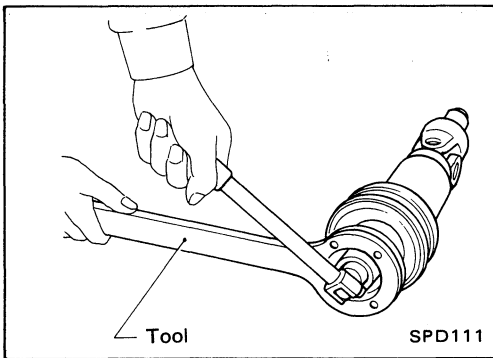

4. Remove companion flange with puller.

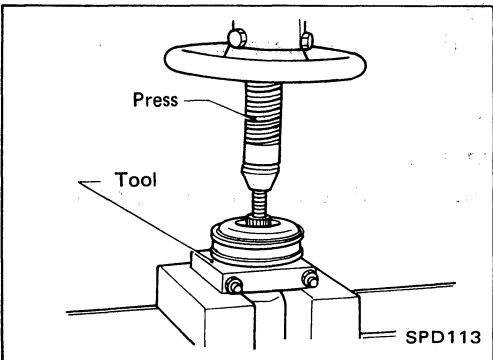

5. Remove center bearing with Tool and press.

Tool number: ST30031000 (J22912-01)

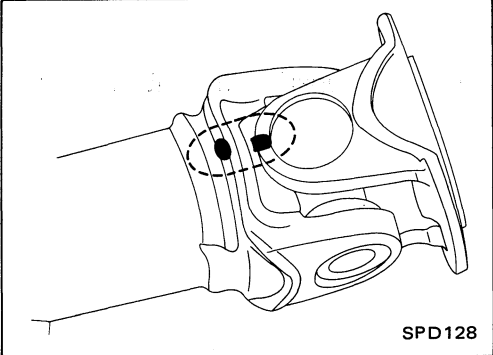

JOURNAL (63H, 71H and 80B)

63A: Do not disassemble.

1. Put match marks on shaft and flange or yoke.

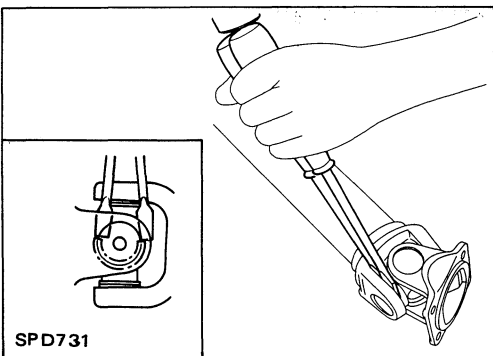

2. Remove snap ring.

PROPELLER SHAFT

Disassembly (Cont'd)

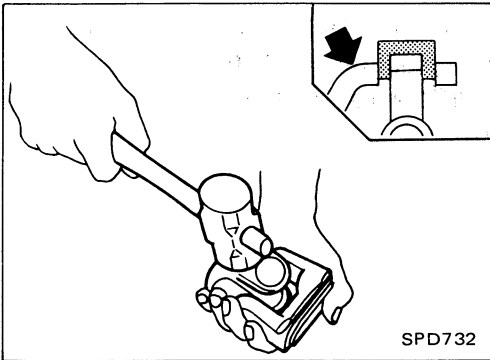

3. Remove pushed out journal bearing by lightly tapping yoke with a hammer, taking care not to damage journal and yoke hole.

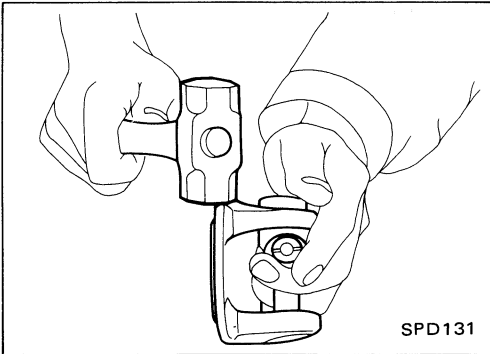

4. Remove bearing at opposite side in above operation. Put marks on disassembled parts so that they can be reinstalled in their original positions from which they were removed.

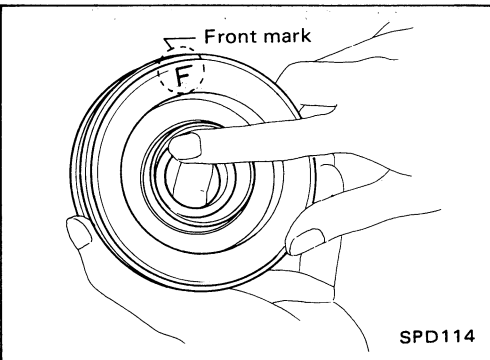

Assembly

CENTER BEARING

- When installing center bearing, position the "F" mark on center bearing toward front of vehicle.
- Apply a coat of multi-purpose lithium grease containing molybdenum disulfide to the end face of the center bearing and both sides of the washer.

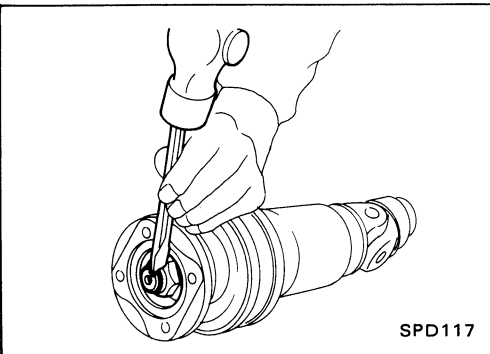

- Stake the nut. Always use new one.
- Align match marks when assembling tubes.

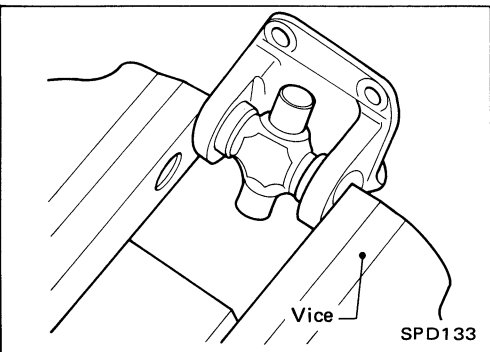

JOURNAL (63H, 71H and 80B)

1. Assemble journal bearing. Apply recommended multi-purpose grease on bearing inner surface. When assembling, be careful that needle bearing does not fall down.

PROPELLER SHAFT

Assembly (Cont'd)

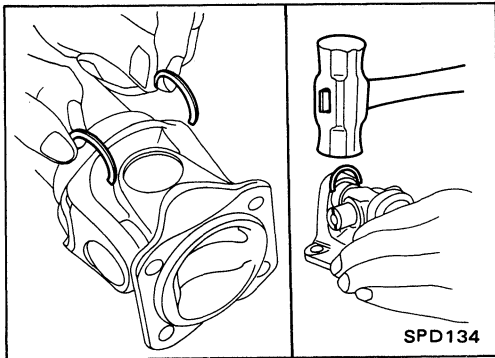

2. Select snap ring that will provide specified play in axial direction of journal, and install them. (Refer to S.D.S.)
Select snap rings with a difference in thickness at both sides within 0.06 mm (0.0024 in).

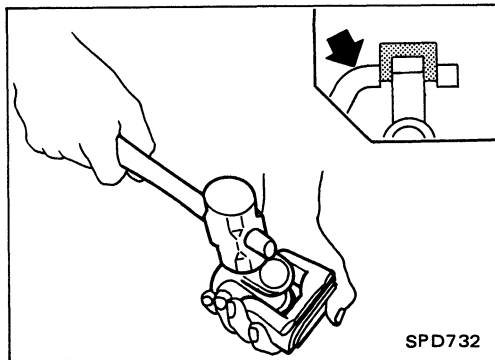

3. Adjust thrust clearance between bearing and snap ring to zero by tapping yoke.

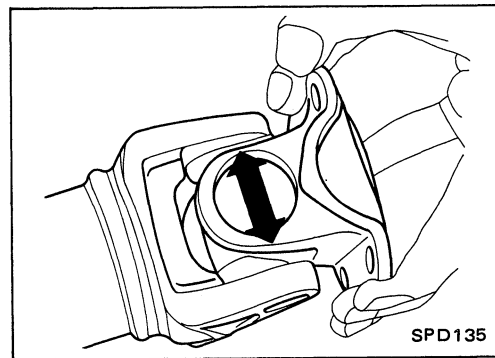

4. Check to see that journal moves smoothly and check for axial play.

Axial play: 0.02 mm (0.0008 in) or less

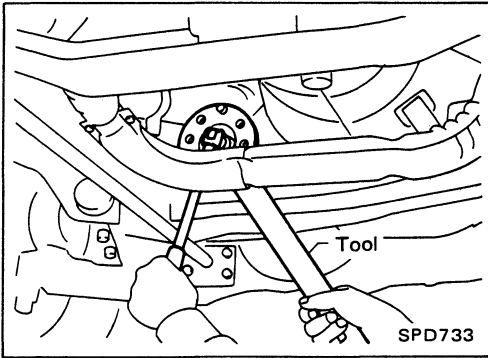

Front Oil Seal Replacement (Front final drive)

1. Remove front propeller shaft.
2. Loosen drive pinion nut.

Tool number: ST38060002 (J34311)

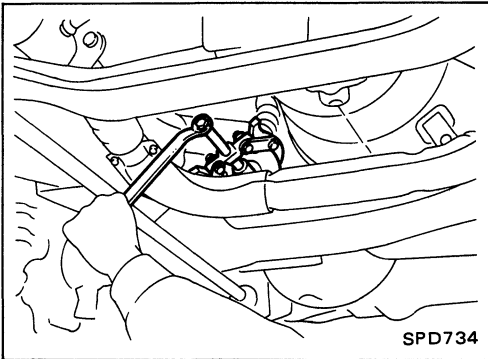

3. Remove companion flange.

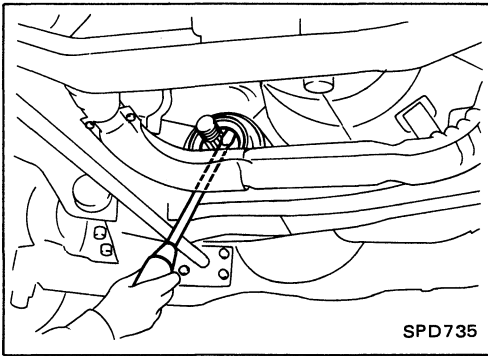

4. Remove front oil seal.

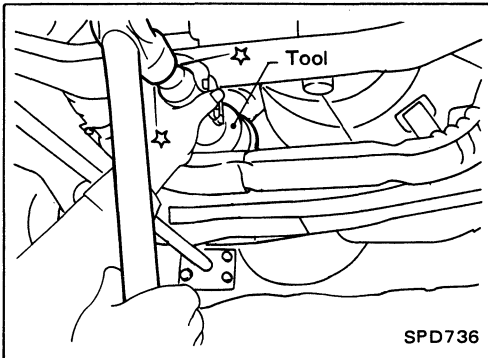

5. Apply multi-purpose grease to cavity at sealing lips of oil seal.
Press front oil seal into carrier.
6. Install companion flange and drive pinion nut.
7. Install propeller shaft.

Tool number:

R180A

ST30720000 (-)

Equivalent tool (J25405)

R200A

KV38100500 (-)

Equivalent tool (J25273)

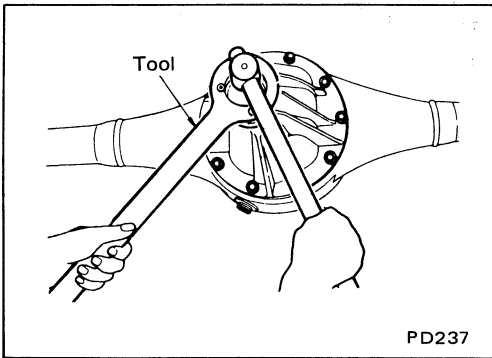

Front Oil Seal Replacement (Rear final drive : Model H233B)

The H190A and C200 final drives must not be replaced the front oil seal on the vehicle as they have collapsible spacer.

1. Remove rear propeller shaft.
2. Loosen drive pinion nut.

Tool number: KV38104700 (J34311)

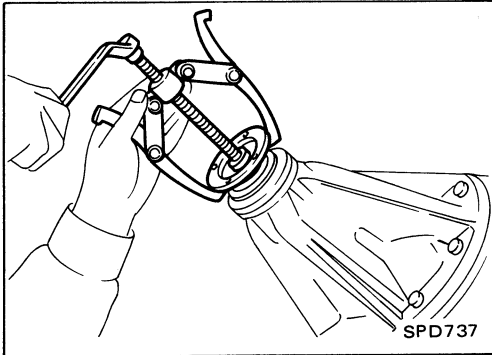

3. Remove companion flange.

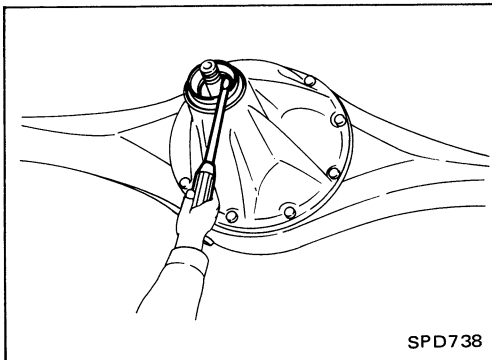

4. Remove front oil seal.

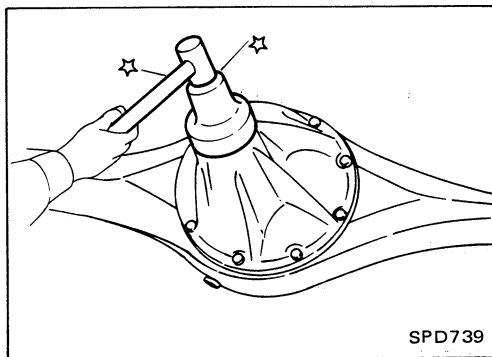

5. Apply multi-purpose grease to cavity at sealing lips of oil seal. Press front oil seal into carrier.
6. Install companion flange and drive pinion nut.
7. Install rear propeller shaft.

Tool number: (J25273)

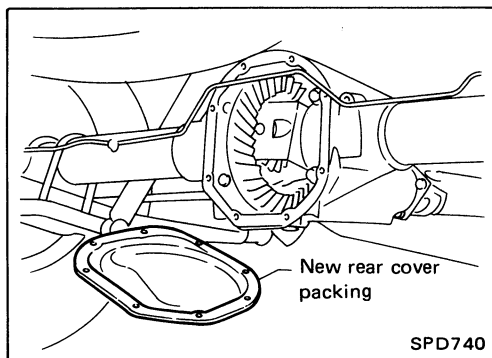

Rear Cover Packing Replacement (Rear final drive : Model C200)

1. Drain gear oil.
2. Remove rear cover and rear cover packing.
3. Install new rear cover packing and rear cover.
4. Fill final drive with recommended gear oil.

REMOVAL AND INSTALLATION (Final Drive : Model R180A and R200A)

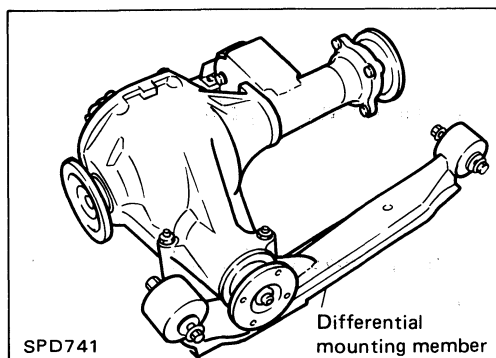

Removal

1. Remove front propeller shaft.
2. Remove drive shaft. Refer to FA section.
3. Remove engine mounting bolts and raise up engine.
4. Remove front final drive together with differential mounting member.

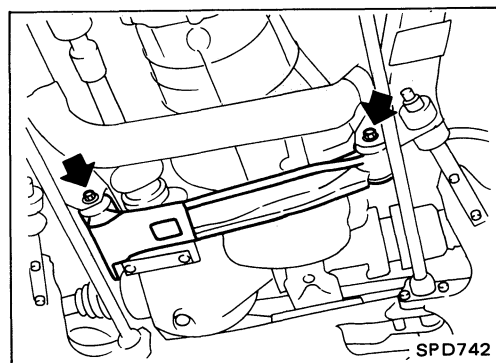

Installation

1. Install front final drive assembly together with differential mounting member.

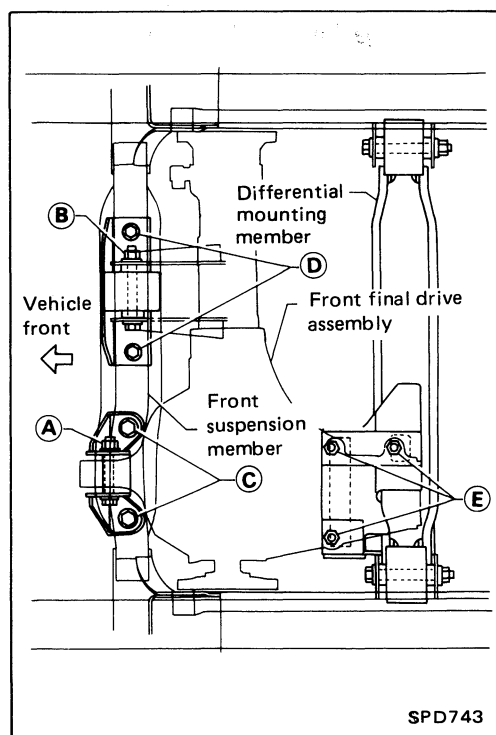

2. Perform tightening front final drive securing bolts and nuts by following procedure to prevent drive train vibration.

- (1) Temporarily tighten nut **A**.
- (2) Temporarily tighten nut **B**.
- (3) Tighten bolt **C** to the torque of 68 to 87 N·m (6.9 to 8.9 kg-m, 50 to 64 ft-lb).
- (4) Tighten bolt **D** to the torque of 68 to 87 N·m (6.9 to 8.9 kg-m, 50 to 64 ft-lb).
- (5) Tighten nut **A** to the torque of 68 to 87 N·m (6.9 to 8.9 kg-m, 50 to 64 ft-lb).
- (6) Tighten nut **B** to the torque of 68 to 87 N·m (6.9 to 8.9 kg-m, 50 to 64 ft-lb).
- (7) Tighten nut **E** to the torque of 68 to 87 N·m (6.9 to 8.9 kg-m, 50 to 64 ft-lb).

3. Install drive shaft. Refer to FA section.
4. Install front propeller shaft.

Removal

- Remove propeller shaft.
- Insert plug into rear oil seal after removing propeller shaft.
- Remove axle shaft.
Refer to RA section.

CAUTION:

- Be careful not to damage spline, sleeve yoke and front oil seal when removing propeller shaft.

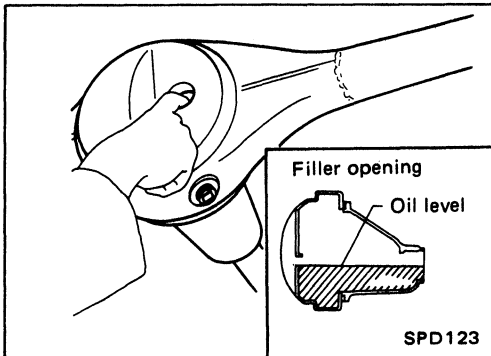

Installation

- Fill final drive with recommended gear oil.

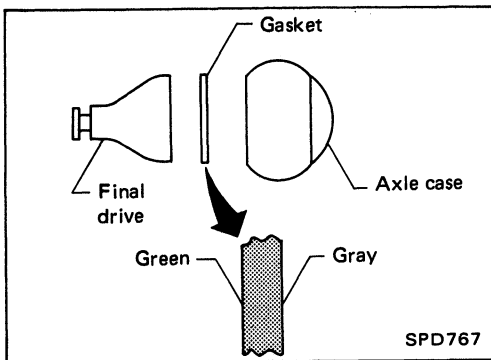

- Pay attention to the direction of gasket (H233B only).

REMOVAL AND INSTALLATION (Final Drive : Model C200)

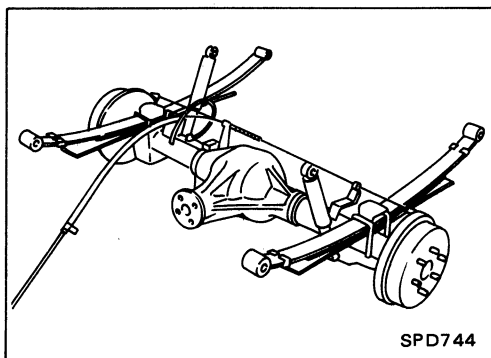

Removal

1. Remove rear propeller shaft.
Insert plug into transmission rear oil seal after removing propeller shaft.
2. Remove rear axle case assembly with leaf springs. Refer to RA section.
3. Drain gear oil.
4. Draw out axle shafts. Refer to RA section.

Installation

1. Install axle shafts. Refer to RA section.
2. Install rear axle case assembly. Refer to RA section.
3. Install propeller shaft.
4. Fill final drive with recommended gear oil.

- ⊗ : Always replace.
- ☆ : Adjustment is required.
- * : Using locking agent [Locktite (stud lock) or equivalent]
- ☞ : N-m (kg-m, ft-lb)

PD-20

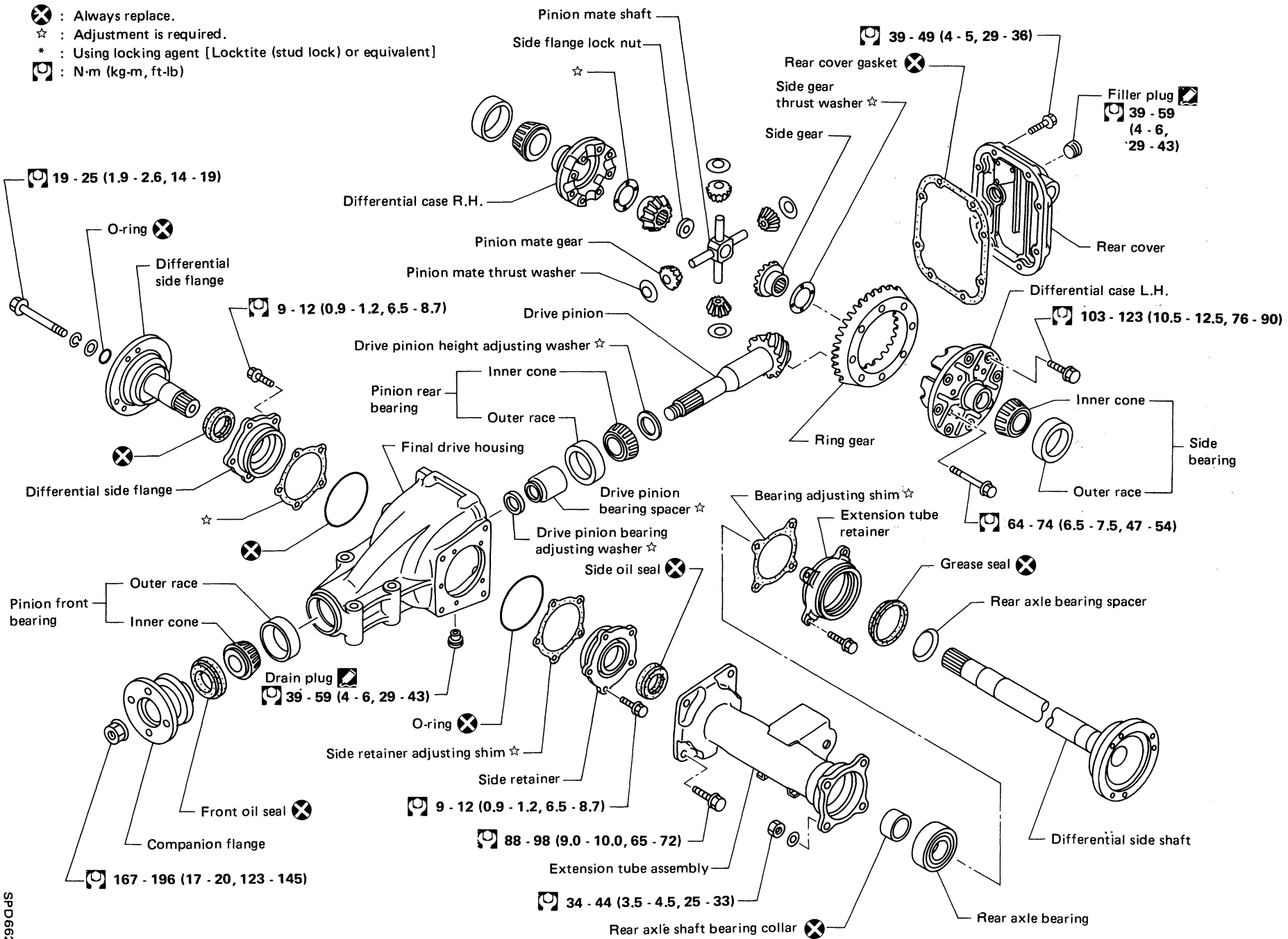

DISASSEMBLY (Model R180A)

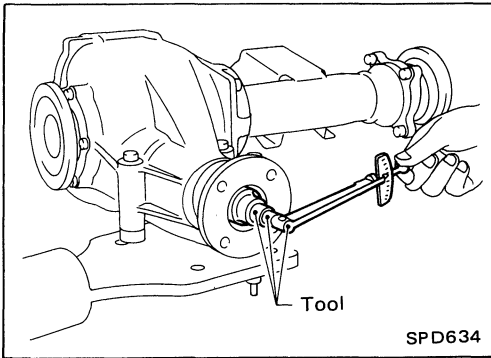

Pre-inspection

Before disassembling final drive, perform the following inspection.

- Total preload
 - 1) Turn drive pinion in both directions several times to set bearing rollers.
 - 2) Check total preload with Tool.

Tool number: ST3127S000 (See J25765-A)

Total preload:

1.0 - 2.3 N·m

(10 - 23 kg·cm, 8.7 - 20.0 in·lb)

- Ring gear to drive pinion backlash
Check backlash of ring gear with a dial indicator at several points.

Ring gear-to-drive pinion backlash:

0.13 - 0.18 mm (0.0051 - 0.0071 in)

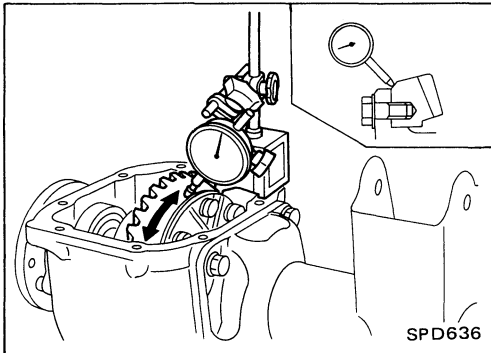
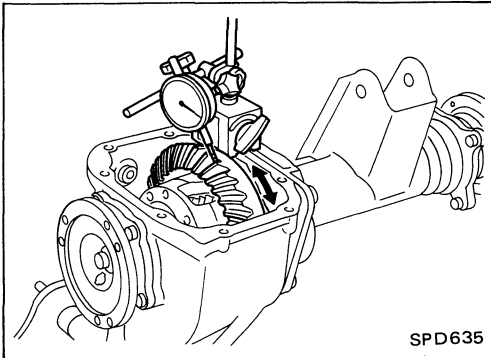

- Ring gear runout
Check runout of ring gear with a dial indicator.
Runout limit:
0.05 mm (0.0020 in)
- Tooth contact
Check tooth contact. (Refer to ADJUSTMENT.)

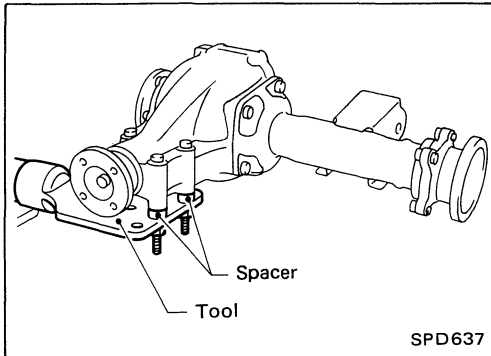

Final Drive Housing

1. Using three spacers [20 mm (0.79 in)], mount final drive assembly on Tool.

Tool number:

KV38100800 (-)

Equivalent tool (J34310), (J25604)

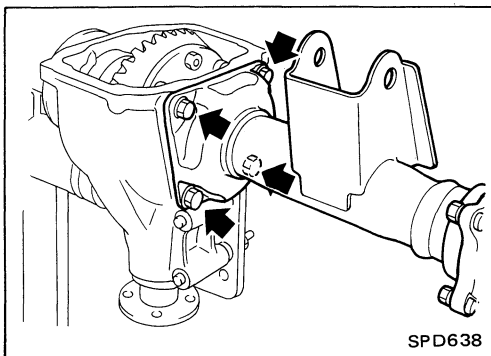

2. Remove extension tube and differential side shaft assembly.

DISASSEMBLY (Model R180A)

Final Drive Housing (Cont'd)

3. Remove differential side flange.

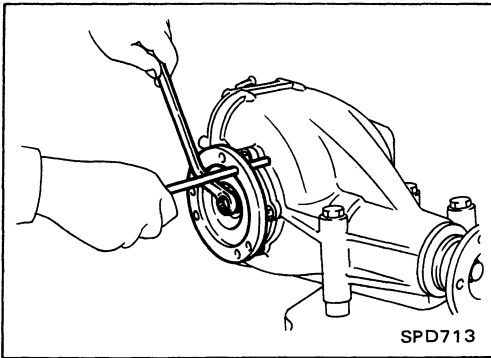

4. Mark side retainers for identification. Remove side retainers. Be careful not to confuse right and left side retainers and shims.

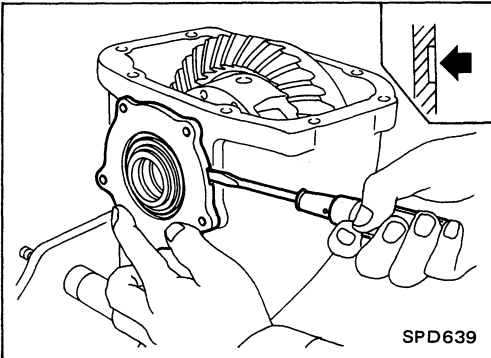

5. Extract differential case from final drive housing.

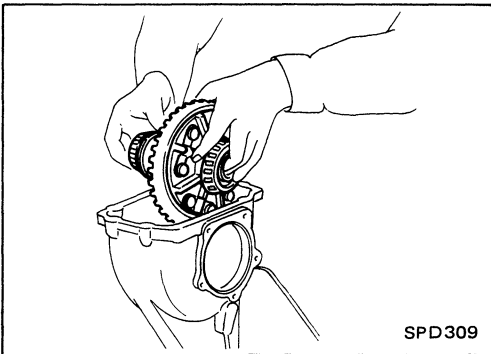

6. Remove side outer races.

Tool number: ST33290001 (J25810-A)

Be careful to keep the side bearing outer races together with their respective inner cones — do not mix them up.

7. Remove side oil seal.

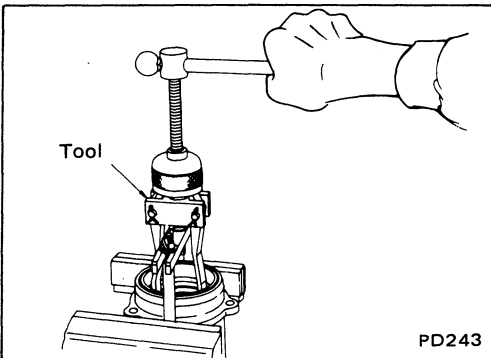

8. Loosen drive pinion nut.

Tool number: ST38060002 (J34311)

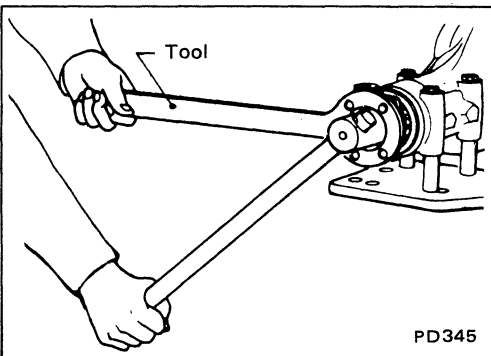

DISASSEMBLY (Model R180A)

Final Drive Housing (Cont'd)

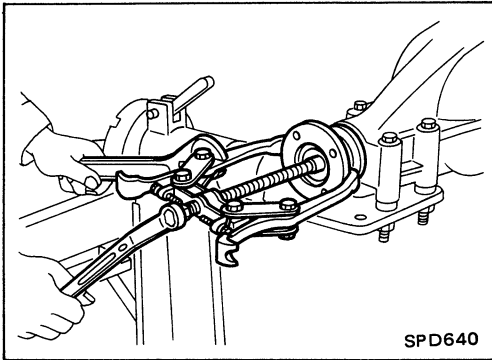

9. Remove companion flange with puller.

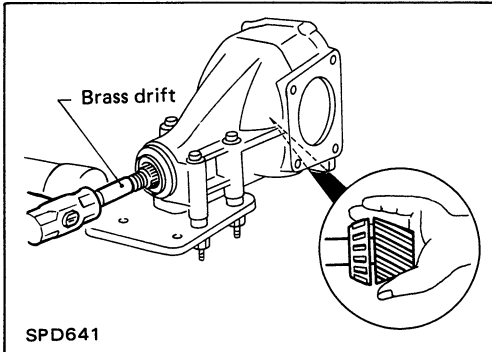

10. Take out drive pinion together with pinion rear bearing inner cone, drive pinion bearing spacer and pinion bearing adjusting washer.
11. Remove front oil seal and pinion front bearing inner cone.

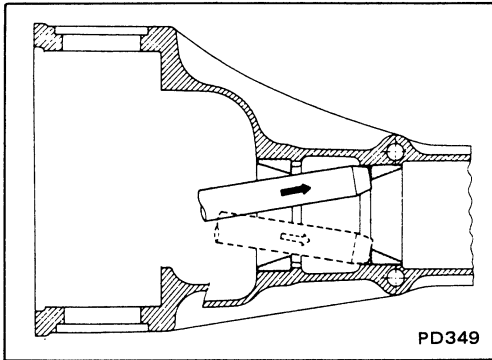

12. Remove pinion front and rear bearing outer races with brass drift.

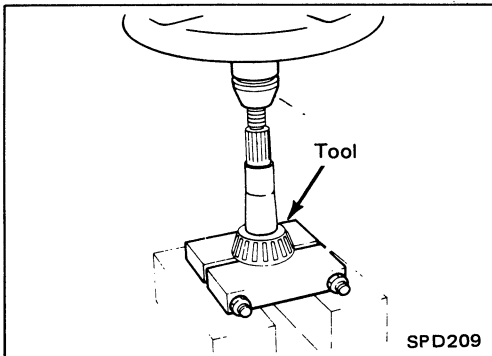

13. Remove pinion rear bearing inner cone and drive pinion adjusting washer.

Tool number: ST30031000 (J22912-01)

DISASSEMBLY (Model R180A)

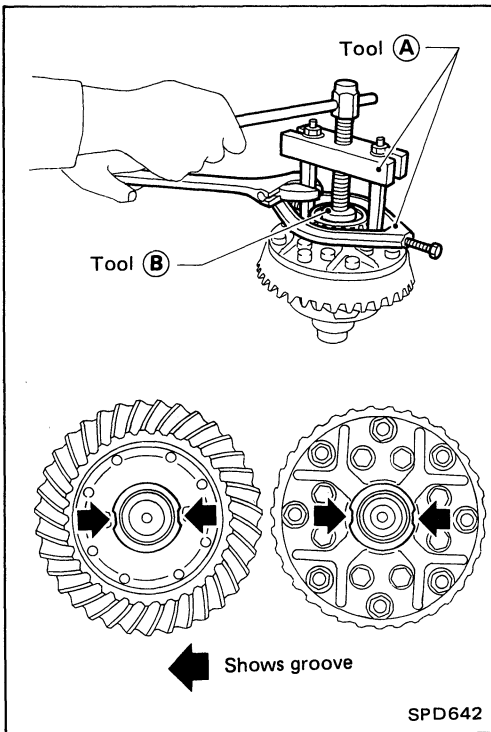

Differential Case

1. Remove side bearing inner cones.

To prevent damage to bearing, engage puller jaws in grooves.

Tool number:

- Ⓐ ST33051001 (—)
Equivalent tool (J22888)
- Ⓑ ST33061000 (J8107-2)

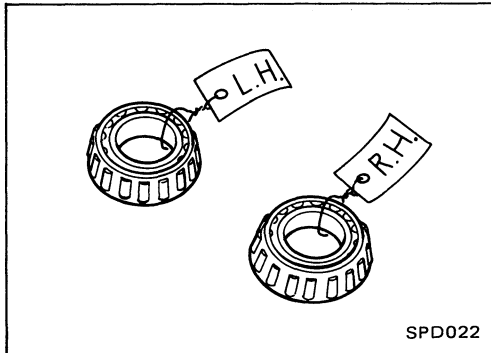

Be careful not to confuse the right and left hand parts.

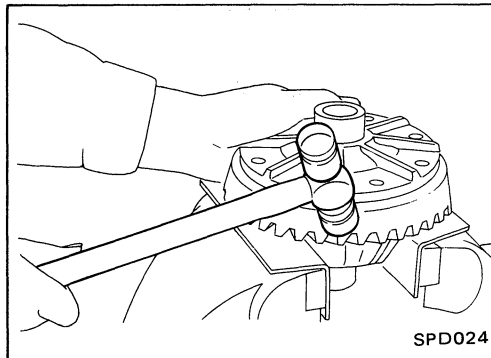

2. Loosen ring gear bolts in a criss-cross fashion.

3. Tap ring gear off differential case with a soft hammer.

Tap evenly all around to keep ring gear from binding.

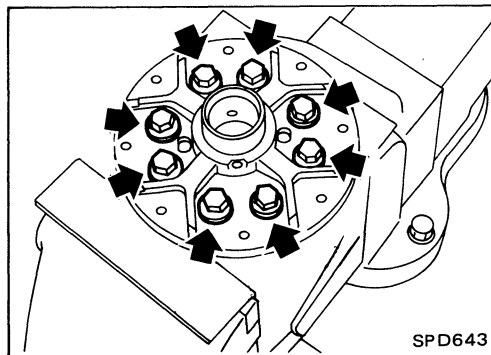

4. Separate differential case L.H. and R.H.

Put match marks on both differential case L.H. and R.H. sides prior to separating them.

DISASSEMBLY (Model R180A)

Extension Tube and Differential Side Shaft

1. Remove differential side shaft assembly from extension tube.

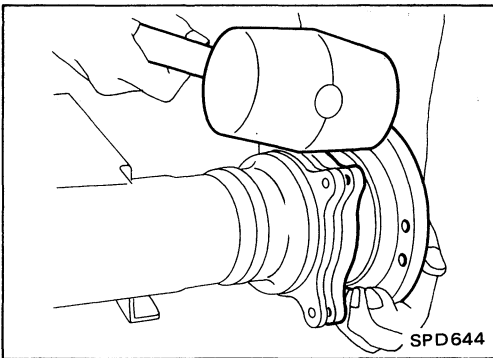

2. Cut rear axle bearing collar with cold chisel. Be careful not to damage differential side shaft.

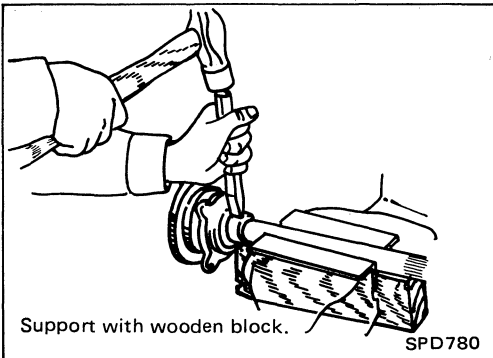

3. Reinstall differential side shaft into extension tube and secure with bolts. Remove rear axle bearing by drawing out differential side shaft from rear axle bearing with puller.

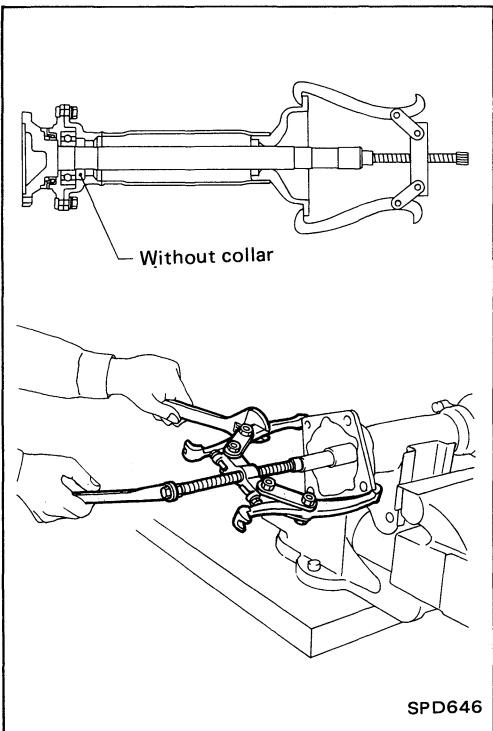

4. Remove grease seal.

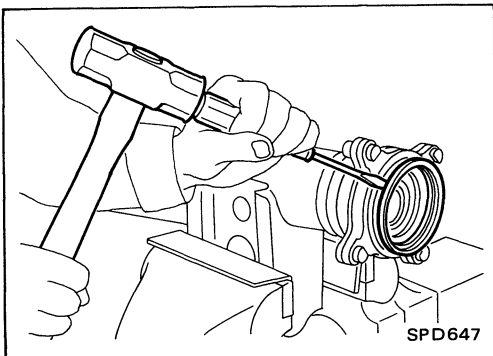

Ring Gear and Drive Pinion

Check gear teeth for scoring, cracking or chipping.

If any damaged part is evident, replace ring gear and drive pinion as a set (hypoid gear set).

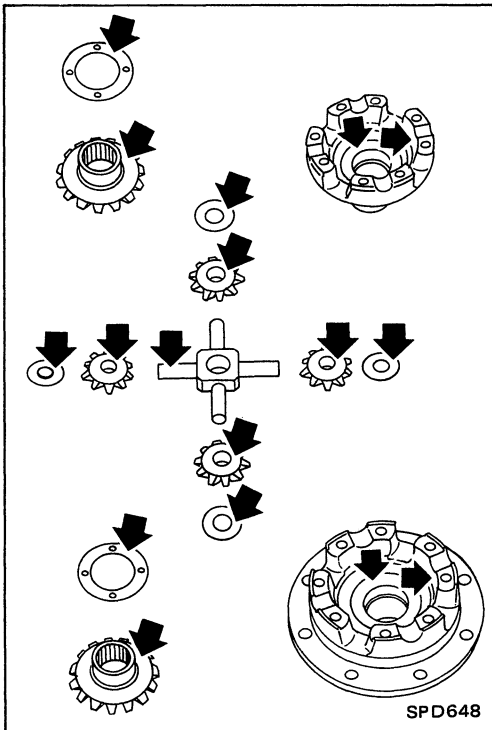

Differential Case Assembly

Check mating surfaces of differential case, side gears, pinion mate gears, pinion mate shaft and thrust washers.

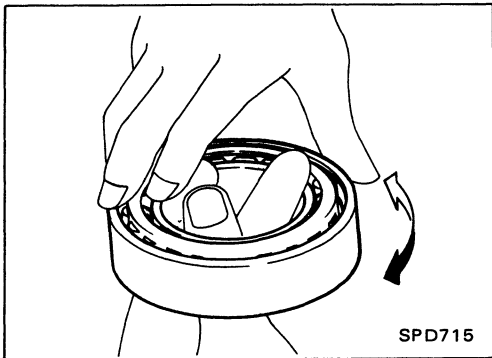

Bearing

1. Thoroughly clean bearing.
2. Check bearings for wear, scratches, pitting or flaking. Check tapered roller bearing for smooth rotation. If damaged, replace outer race and inner cone as a set.

ADJUSTMENT (Model R180A)

For quiet and reliable final drive operation, the following five adjustments must be made correctly:

1. Side bearing preload.
2. Pinion gear height.
3. Pinion bearing preload.
4. Ring gear-to-pinion backlash. (Refer to ASSEMBLY.)
5. Ring and pinion gear tooth contact pattern.

Side Bearing Preload

(Note: A selection of carrier side bearing preload shims is required for successful completion of this procedure.)

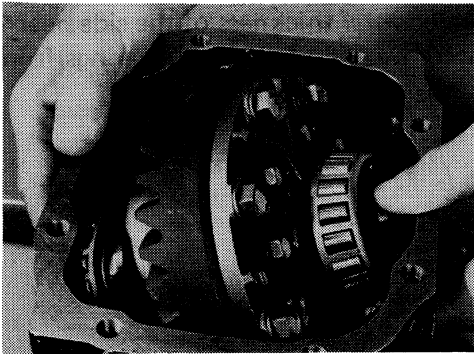

1. Make sure all parts are clean and that the bearings are well lubricated with light oil or Dexron type automatic transmission fluid.
2. Install differential carrier and side bearing assembly into the final drive housing.

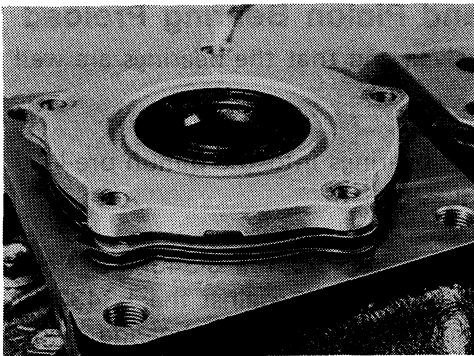

3. Place all of the original side bearing preload shims onto the side bearing retainer that goes at the ring gear end of the carrier.



4. Install both bearing retainers onto the final drive housing and torque the retainer bolts.

Bolt torque specification:

9 - 12 N·m (0.9 - 1.2 kg·m, 6.5 - 7.2 ft·lb)

ADJUSTMENT (Model R180A)

Side Bearing Preload (Cont'd)

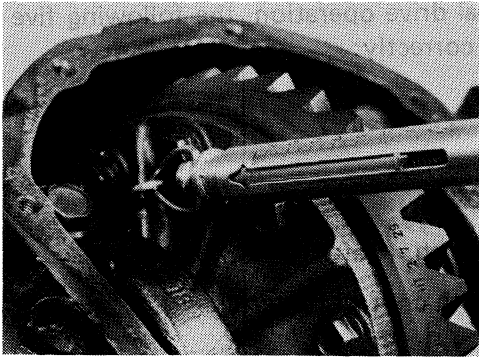

5. Turn the carrier several times to seat the bearings.
6. Measure the carrier turning torque with a spring gauge, J-8129, at the ring gear retaining bolt.

Turning torque specification:

34.3 - 39.2 N (3.5 - 4.0 kg, 7.7 - 8.8 lb)
of pulling force at the ring gear bolt.

7. If the turning torque measured is incorrect, establish the correct bearing preload by adding to or subtracting from the *total* amount of shim thickness.
 - Increase shim thickness to *decrease* turning torque on the carrier.
 - Decrease shim thickness to *increase* turning torque on the carrier.
8. Record the correct, selected *total* thickness of the side bearing preload shims, and remove the carrier and bearings from the final drive housing. Save all shims for later re-use.

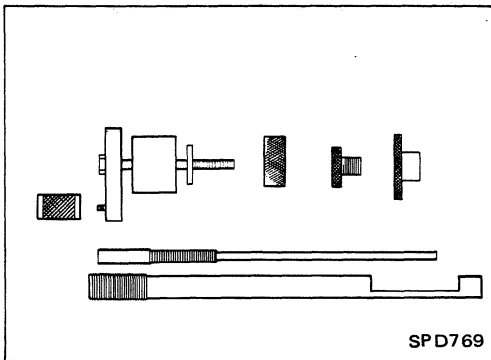
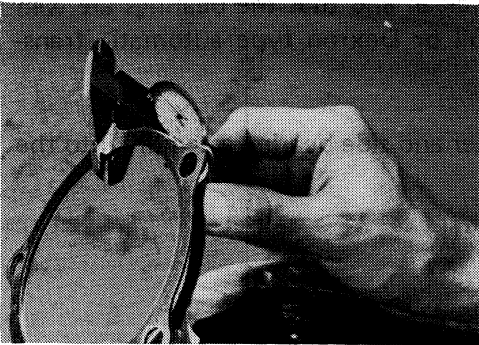

Pinion Gear Height and Pinion Bearing Preload

1. Make sure all parts are clean and that the bearings are well lubricated.
2. Assemble the pinion gear bearings into the pinion pre-load shim selector tool, J-34309.
 - **Front Pinion Bearing** — make sure the J-34309-3 front pinion bearing seat is secured tightly against the J-34309-2 gauge anvil. Then turn the front pinion bearing pilot, J-34309-7, to secure the bearing in its proper position.
 - **Rear Pinion Bearing** — the rear pinion bearing pilot, J-34309-8, is used to center the rear pinion bearing only. The rear pinion bearing locking seat, J-34309-4, is used to lock the bearing to the assembly.

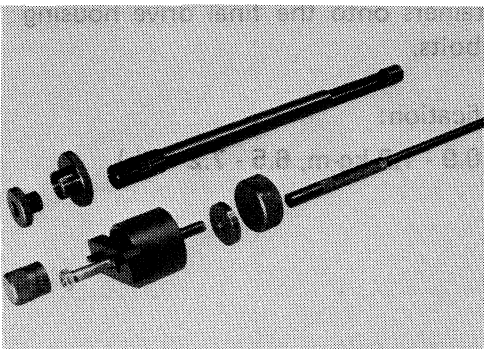

ADJUSTMENT (Model R180A)

Pinion Gear Height and Pinion Bearing Preload (Cont'd)

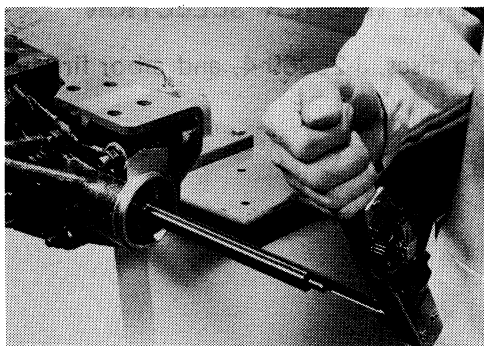
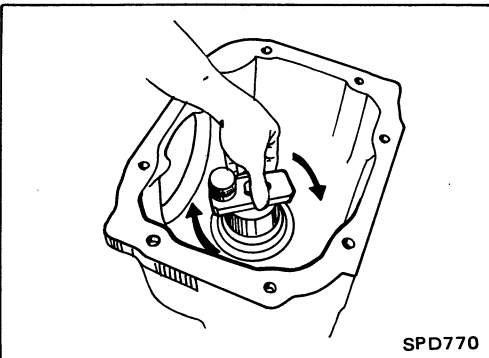
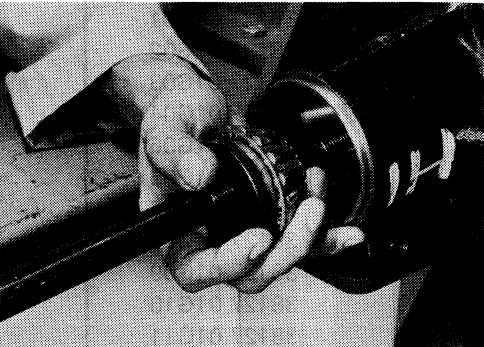
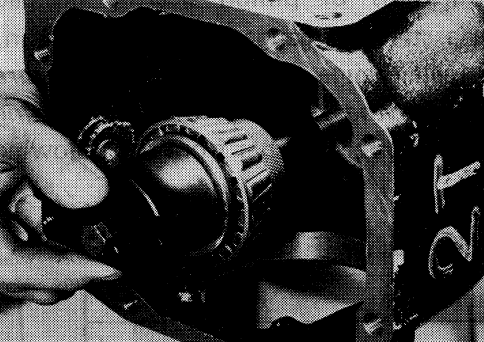
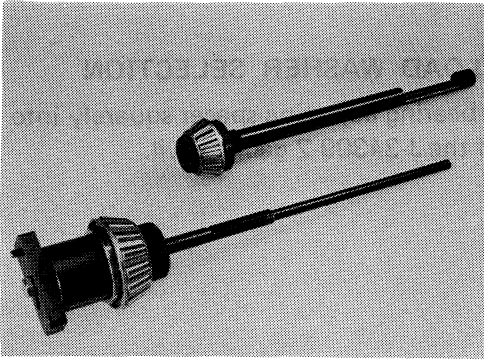

3. Place the pinion preload shim selector tool gauge screw, J34309-1, with the pinion rear bearing inner cone installed, into the final drive housing.

4. Install the J-34309-2 gauge anvil with the front pinion bearing into the final drive housing and assemble it to the J-34309-1 gauge screw. Make sure that the J-34309-16 gauge plate will turn a full 360 degrees, and tighten the two sections by hand.

5. Turn the assembly several times to seat the bearings.

6. Measure the turning torque at the end of the J-34309-2 shaft using torque wrench J-25765-A.

Turning torque specification:

0.6 - 1.0 N-m (6 - 10 kg-cm, 5.2 - 8.7 in-lb)

7. Place the J-34309-10 "R180A" pinion height adapter onto the gauge plate and tighten it by hand.

CAUTION:

Make sure all machined surfaces are clean.

ADJUSTMENT (Model R180A)

Pinion Gear Height and Pinion Bearing Preload (Cont'd)



PINION BEARING PRELOAD WASHER SELECTION

8. Place the solid pinion bearing adjusting spacer squarely into the recessed portion of the J-34309-2 gauge anvil.

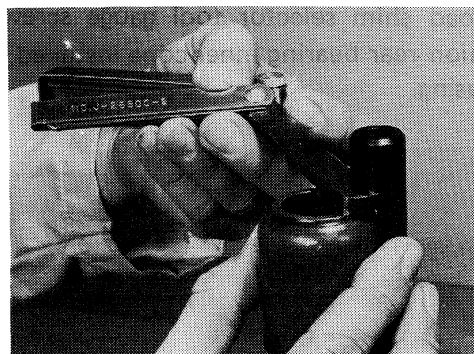

9. Select the correct thickness of pinion bearing preload adjusting washer using a standard gauge of 6 mm (0.24 in) and your J-34309-101 feeler gauge. *The exact total measure you get with the gauges is the thickness of the adjusting washer required.* Select the correct washer from the following chart.

Drive pinion bearing adjusting washer (R180A)

Thickness mm (in)	Part No.
6.59 (0.2594)	38127 01G00
6.57 (0.2587)	38127 01G01
6.55 (0.2579)	38127 01G02
6.53 (0.2571)	38127 01G03
6.51 (0.2563)	38127 01G04
6.49 (0.2555)	38127 01G05
6.47 (0.2547)	38127 01G06
6.45 (0.2539)	38127 01G07
6.43 (0.2531)	38127 01G08
6.41 (0.2524)	38127 01G09
6.39 (0.2516)	38127 01G10
6.37 (0.2508)	38127 01G11
6.35 (0.2500)	38127 01G12
6.33 (0.2492)	38127 01G13
6.31 (0.2484)	38127 01G14

10. Set your selected, correct pinion bearing preload adjusting washer aside for use when assembling the pinion and bearings into the final drive housing.

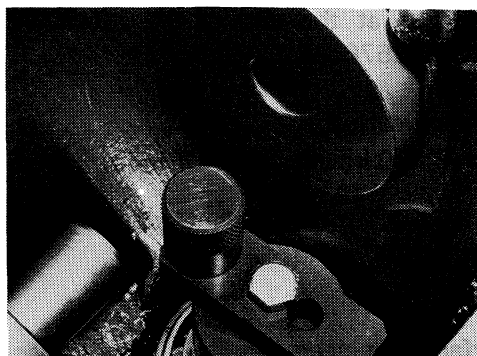

PINION HEIGHT ADJUSTING WASHER SELECTION

11. Position the side bearing discs, J-25269-4, and arbor firmly into the side bearing bores.

ADJUSTMENT (Model R180A)

Pinion Gear Height and Pinion Bearing Preload (Cont'd)



12. Select the correct *standard* pinion height adjusting washer thickness using a standard gauge of 3 mm (0.12 in) and your J-34309-101 feeler gauge. Measure the distance between the J-34309-10 "R180A" pinion height adapter and the arbor.

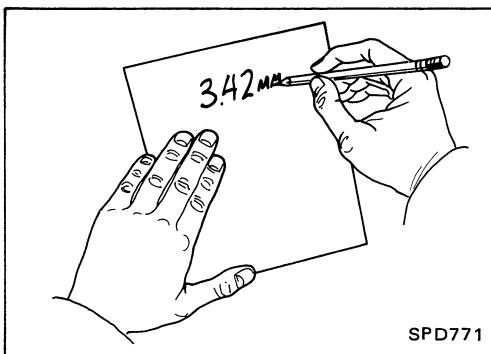

13. Write down your exact total measurement.

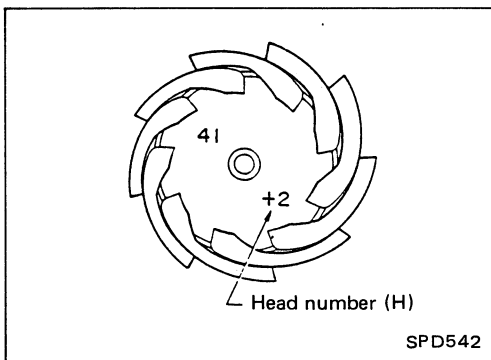

14. Correct the pinion height washer size by referring to the "pinion head number."

Note: There are two numbers painted on the pinion gear. The first one refers to the pinion and ring gear as a matched set and should be the same as the number on the ring gear. The second number is the "pinion head height number," and it refers to the ideal pinion height from standard for quietest operation. Use the following chart to determine the correct pinion height washer.

Pinion Head Height Number	Add or Remove from the Standard Pinion Height Washer Thickness Measurement
-6	Add 0.06 mm (0.0024 in)
-5	Add 0.05 mm (0.0020 in)
-4	Add 0.04 mm (0.0016 in)
-3	Add 0.03 mm (0.0012 in)
-2	Add 0.02 mm (0.0008 in)
-1	Add 0.01 mm (0.0004 in)
0	Use the selected washer thickness
+1	Subtract 0.01 mm (0.0004 in)
+2	Subtract 0.02 mm (0.0008 in)
+3	Subtract 0.03 mm (0.0012 in)
+4	Subtract 0.04 mm (0.0016 in)
+5	Subtract 0.05 mm (0.0020 in)
+6	Subtract 0.06 mm (0.0024 in)

ADJUSTMENT (Model R180A)

Pinion Gear Height and Pinion Bearing Preload (Cont'd)

15. Select the correct pinion height washer from the following chart.

Drive pinion height adjusting washer (R180A)

Thickness mm (in)	Part No.
3.09 (0.1217)	38154-P6017
3.12 (0.1228)	38154-P6018
3.15 (0.1240)	38154-P6019
3.18 (0.1252)	38154-P6020
3.21 (0.1264)	38154-P6021
3.24 (0.1276)	38154-P6022
3.27 (0.1287)	38154-P6023
3.30 (0.1299)	38154-P6024
3.33 (0.1311)	38154-P6025
3.36 (0.1323)	38154-P6026
3.39 (0.1335)	38154-P6027
3.42 (0.1346)	38154-P6028
3.45 (0.1358)	38154-P6029
3.48 (0.1370)	38154-P6030
3.51 (0.1382)	38154-P6031
3.54 (0.1394)	38154-P6032
3.57 (0.1406)	38154-P6033
3.60 (0.1417)	38154-P6034
3.63 (0.1429)	38154-P6035
3.66 (0.1441)	38154-P6036

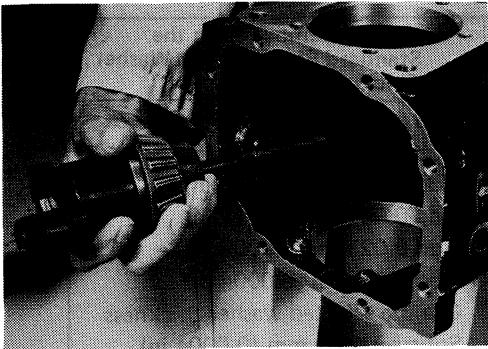

16. Remove the J-34309 pinion preload shim selector tool from the final drive housing and disassemble to retrieve the pinion bearings.

ADJUSTMENT (Model R180A)

Tooth Contact

Gear tooth contact pattern check is necessary to verify correct relationship between ring gear and drive pinion.

Hypoid gear sets which are not positioned properly in relation to one another may be noisy, or have short life, or both. With a pattern check, the most desirable contact for low noise level and long life can be assured.

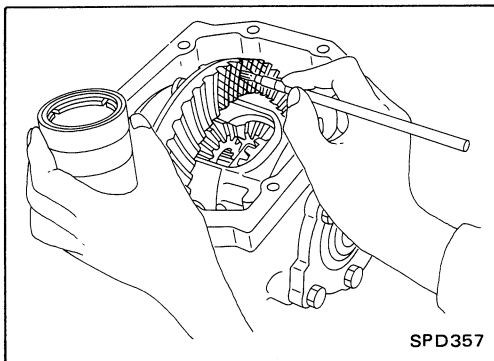

1. Thoroughly clean ring gear and drive pinion teeth.
2. Sparingly apply a mixture of powdered ferric oxide and oil or equivalent to 3 or 4 teeth of ring gear drive side.

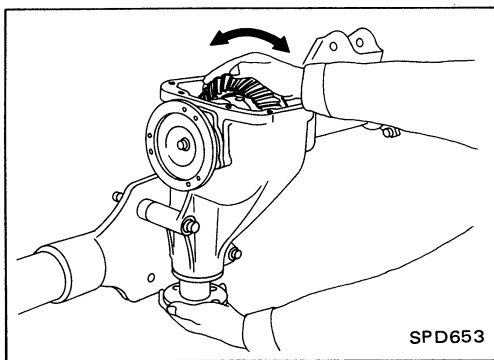

3. Hold companion flange steady by hand and rotate the ring gear in both directions.

Usually the pattern will be correct if you have calculated the shims correctly and the backlash is correct. However, in rare cases you may have to use trial-and-error processes until you get a good tooth contact pattern. The tooth pattern is the best indication of how well a differential has been set up.

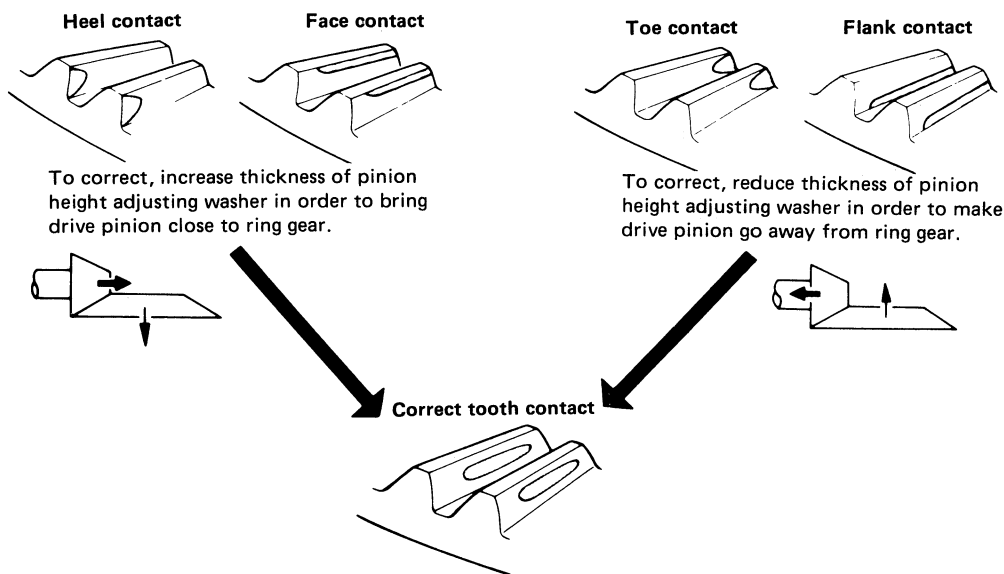

SPD007

Extension Tube and Differential Side Shaft

1. Measure rear axle bearing end play.

Rear axle bearing end play (A – B):

0.1 mm (0.0039 in) or less

The end play can be adjusted with bearing adjusting shim.
(Refer to S.D.S.)

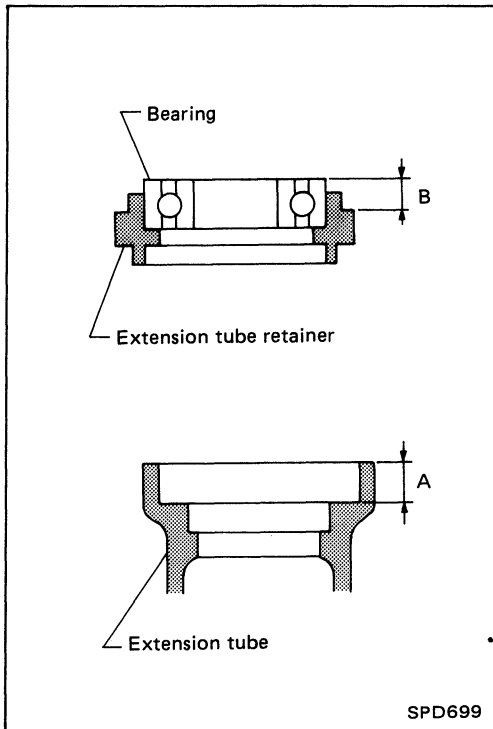

2. Install grease seal.

Tool number: (J35764)

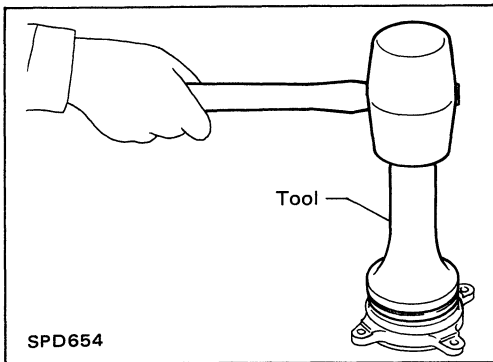

3. Install extension tube retainer, rear axle bearing and rear axle shaft bearing collar on differential side shaft.
4. Install differential side shaft assembly into extension tube.

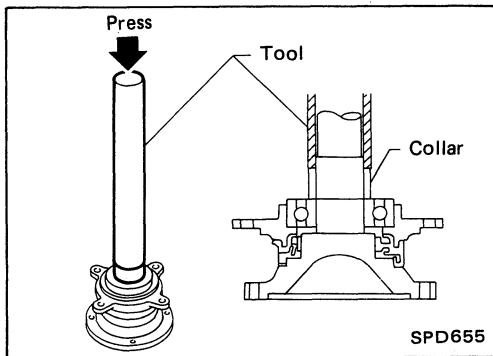

Differential Case

1. Measure clearance between side gear thrust washer and differential case.

Clearance between side gear thrust washer and differential case (A – B):

0.10 - 0.20 mm (0.0039 - 0.0079 in)

The clearance can be adjusted with side gear thrust washer. (Refer to S.D.S.)

2. Apply gear oil to gear tooth surfaces and thrust surfaces and check to see they turn properly.

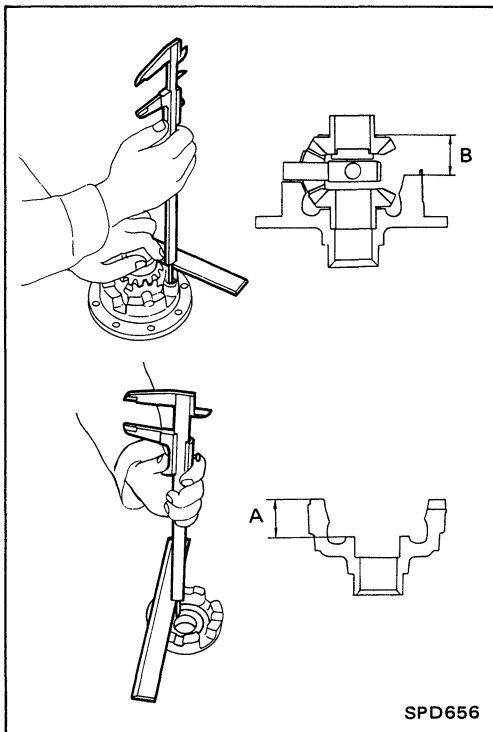

3. Install differential case L.H. and R.H.

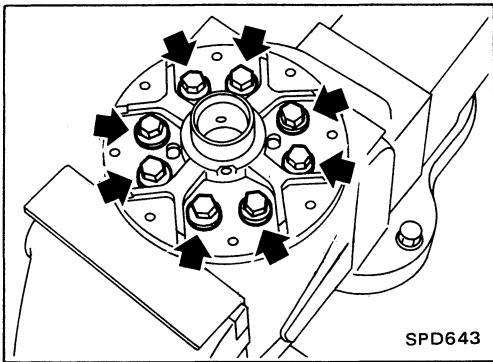

4. Place differential case on ring gear.
5. Apply locking agent [Locktite (stud lock) or equivalent] to ring gear bolts, and install them.

Tighten bolts in a criss-cross fashion, lightly tapping bolt head with a hammer.

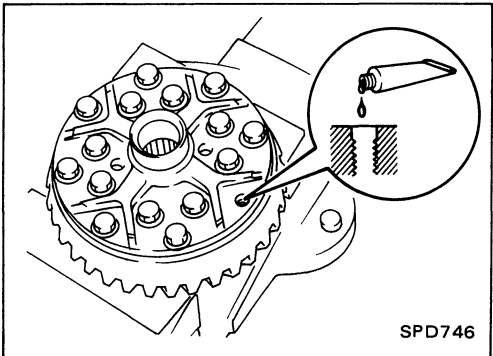

6. Press-fit side bearing inner cones on differential case with Tool.

Tool number:

- (A) ST33230000 (J25805-01)**
- (B) ST33061000 (J8107-2)**

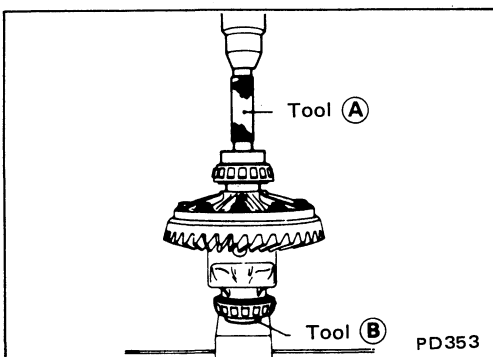

Final Drive Housing

1. Press-fit front and rear bearing outer races with Tools.

Tool number:

- (A) ST30611000 (J25742-1)
- (B) ST30621000 (J25742-5)
- (C) ST30701000 (J25742-2)

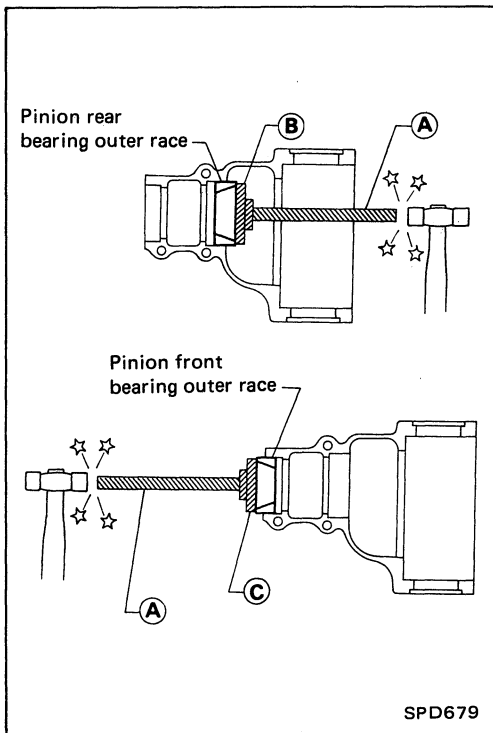

2. Select pinion bearing adjusting washer and drive pinion bearing spacer, referring to ADJUSTMENT.
3. Install drive pinion height adjusting washer in drive pinion, and press-fit pinion rear bearing inner cone in it, using press and Tool.

Tool number: ST30901000 (-)
Equivalent tool (J26010-01)

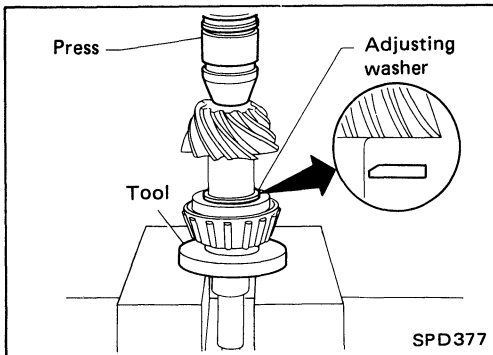

4. Place pinion front bearing inner cone in final drive housing.

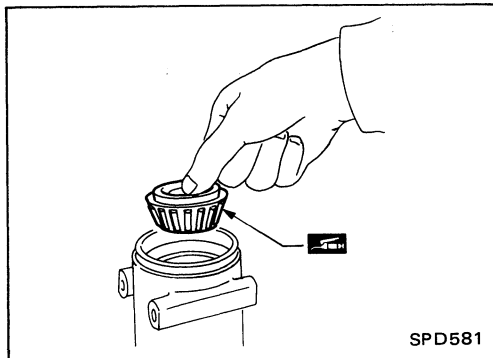

5. Apply multi-purpose grease to cavity at sealing lips of oil seal. Install front oil seal.

Tool number: ST30720000 (-)
Equivalent tool (J25405)

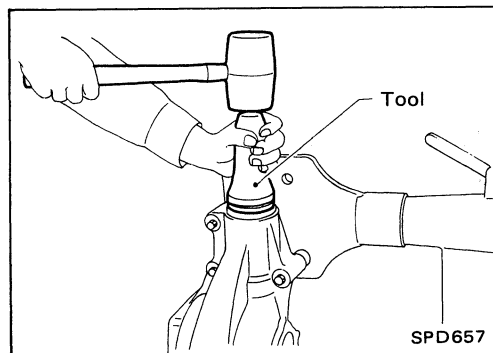

ASSEMBLY (Model R180A)

Final Drive Housing (Cont'd)

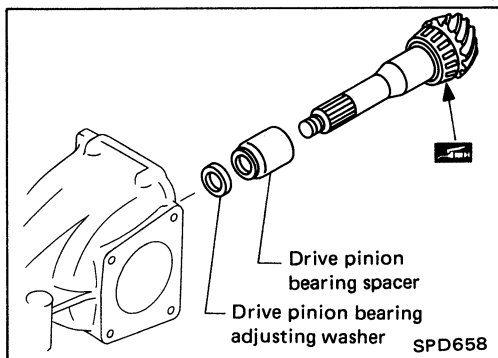

6. Place drive pinion bearing spacer, pinion bearing adjusting washer and drive pinion in final drive housing.

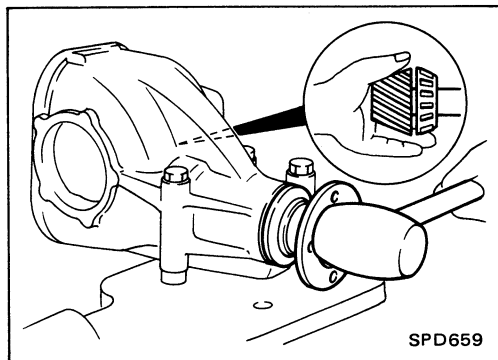

7. Insert companion flange into drive pinion by tapping the companion flange with a soft hammer.

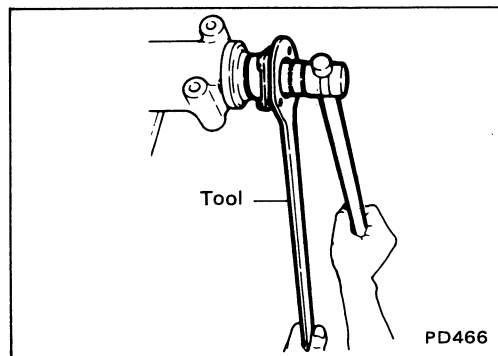

8. Tighten pinion nut to the specified torque.
The threaded portion of drive pinion and pinion nut should be free from oil or grease.

Tool number: ST38060002 (J34311)

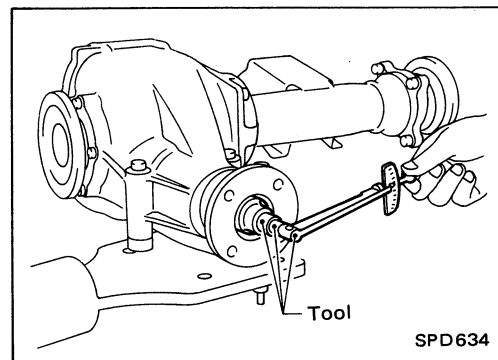

9. Turn drive pinion in both directions several revolutions, and measure pinion bearing preload.

Tool number: ST3127S000 (J25765-A)

Pinion bearing preload:

0.9 - 1.7 N·m

(9 - 17 kg·cm, 7.8 - 14.8 in·lb)

When pinion bearing preload is outside the specifications, replace pinion bearing adjusting washer and spacer with a different thickness.

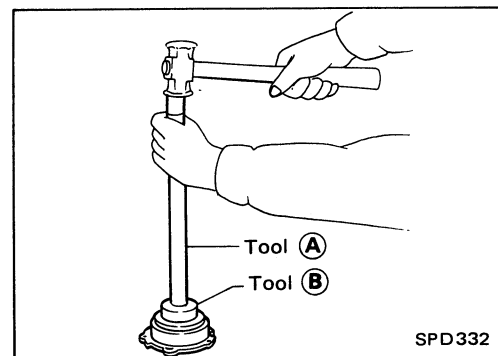

10. Select side retainer adjusting washer.

Refer to ADJUSTMENT.

11. Press-fit side bearing outer race into side retainer.

Tool number:

(A) ST30611000 (J25742-1)

(B) ST30621000 (J25742-5)

ASSEMBLY (Model R180A)

Final Drive Housing (Cont'd)

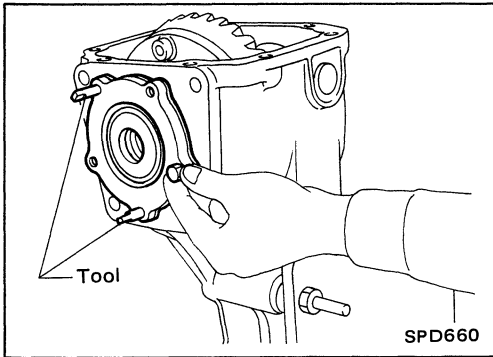

12. Install side oil seal.
13. Install differential case assembly.
14. Place side retainer adjusting shims (Refer to ADJUSTMENT.), and O-ring on side retainer, and install them in final drive housing.

Tool number: ST33720000 (J25817)

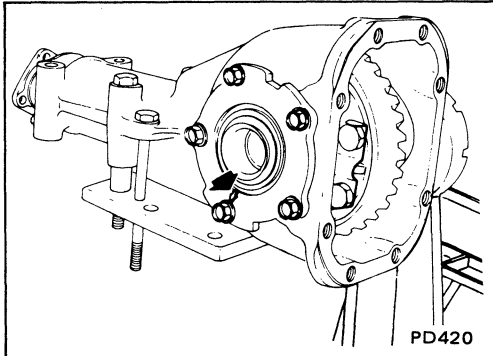

- Align arrows stamped on side retainer and final drive housing.

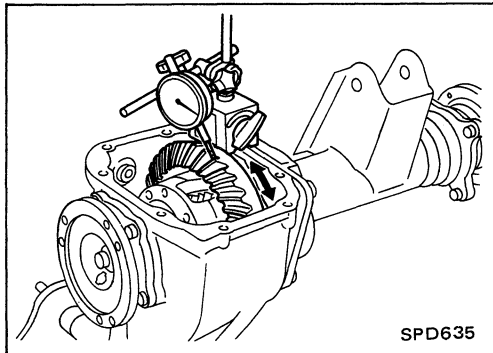

15. Measure ring gear-to-drive pinion backlash with a dial indicator.

Ring gear-to-drive pinion backlash:

0.13 - 0.18 mm (0.0051 - 0.0071 in)

- If backlash is too small, decrease thickness of right shim and increase thickness of left shim by the same amount.

If backlash is too great, reverse the above procedure.

Never change the total amount of shims as it will change the bearing preload.

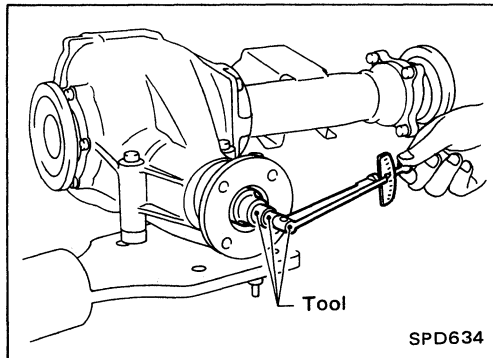

16. Check total preload with Tool.

When checking preload, turn drive pinion in both directions several times to set bearing rollers.

Tool number: ST3127S000 (See J25765-A)

Total preload:

1.0 - 2.3 N·m

(10 - 23 kg·cm, 8.7 - 20.0 in·lb)

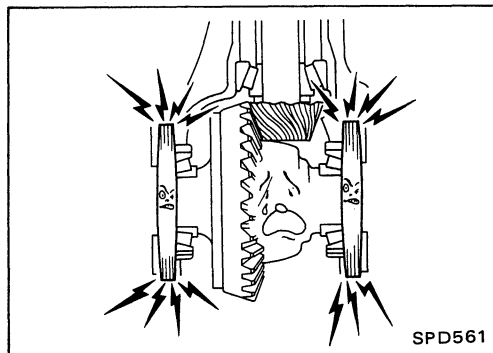

- If preload is too great, add the same amount of shim to each side.

- If preload is too small, remove the same amount of shim from each side.

Never add or remove a different number of shims for each side as it will change ring gear-to-drive pinion backlash.

17. Recheck ring gear-to-drive pinion backlash because increase or decrease in thickness of shims will cause change of ring gear-to-pinion backlash.

ASSEMBLY (Model R180A)

Final Drive Housing (Cont'd)

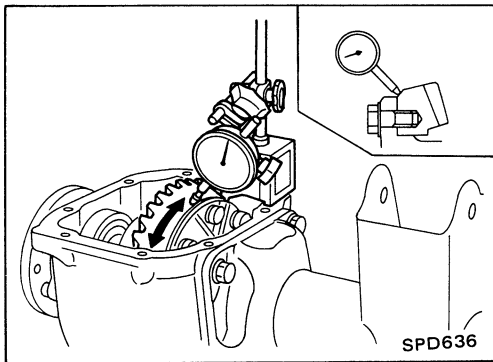

18. Check runout of ring gear with a dial indicator.

Runout limit:

0.08 mm (0.0031 in)

- If backlash varies excessively in different places, the variance may have resulted from foreign matter caught between the ring gear and the differential case.
- If the backlash varies greatly when the runout of the ring gear is within a specified range, the hypoid gear set or differential case should be replaced.

19. Check tooth contact.

Refer to ADJUSTMENT.

20. Install rear cover and gasket.

21. Install extension tube and differential side shaft assembly.

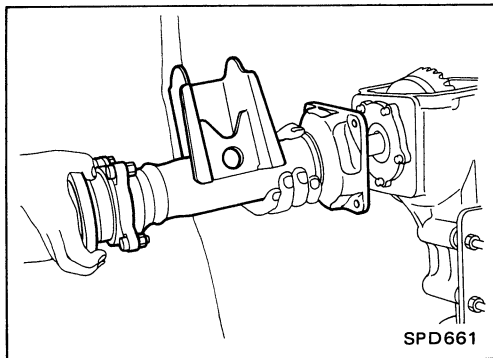

- ⊗ : Always replace.
- ☆ : Adjustment is required.
- * : Using locking agent [Loctite (stud lock) or equivalent]
- 🔧 : N-m (kg-m, ft-lb)

PD-40

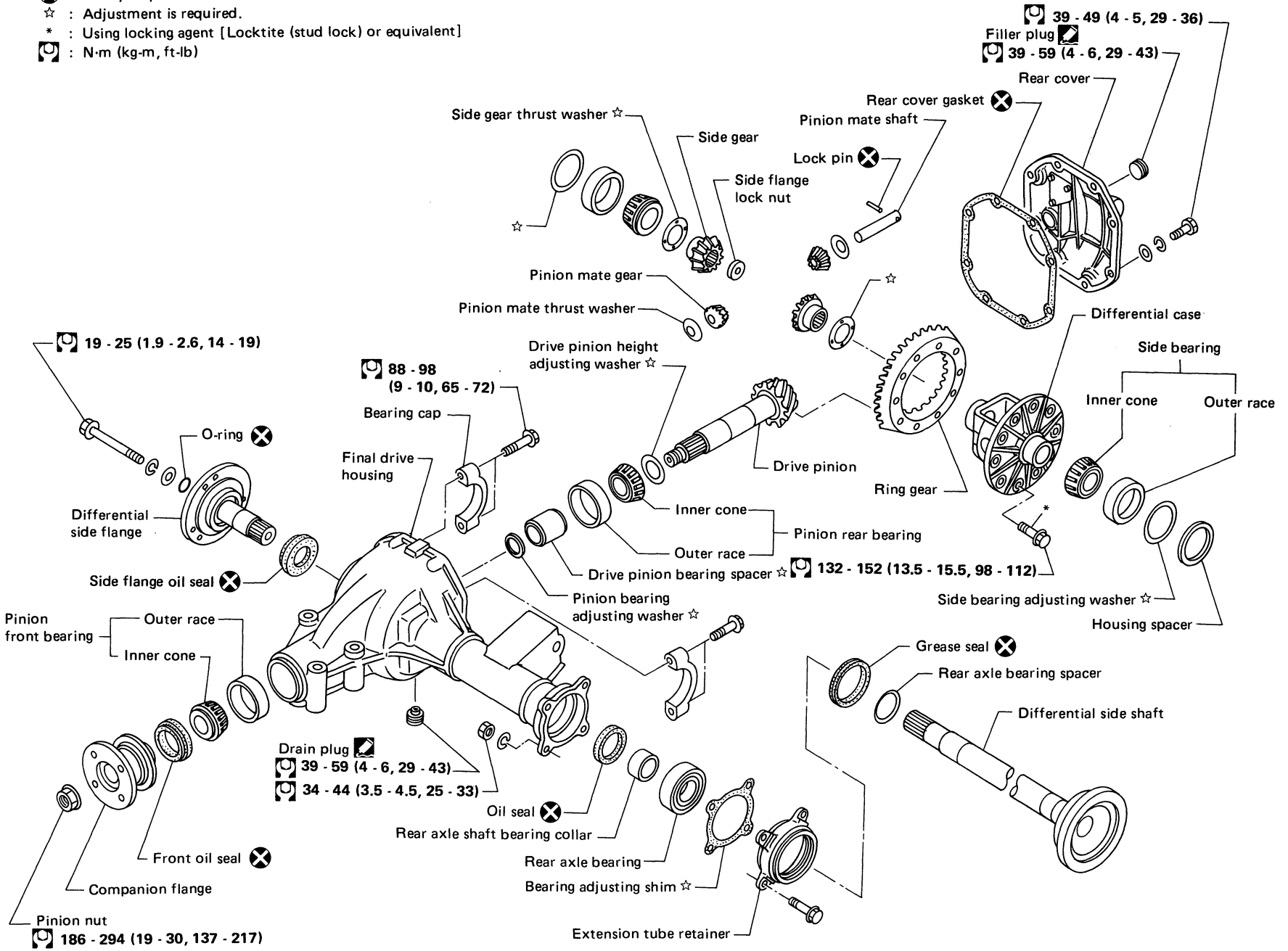

DISASSEMBLY (Model R200A)

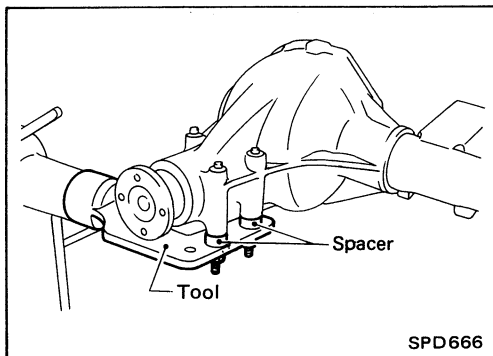
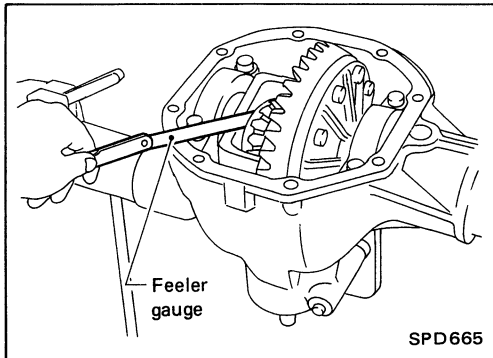
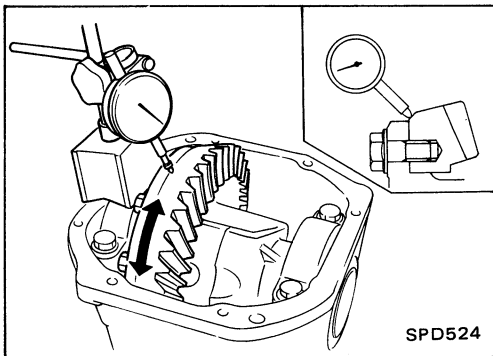
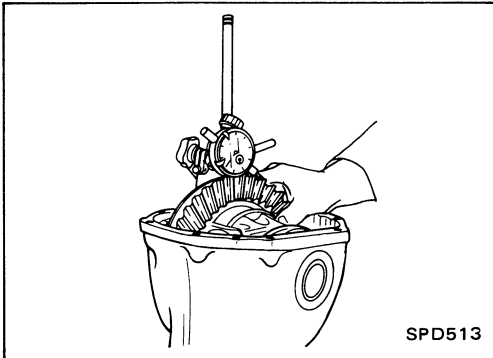
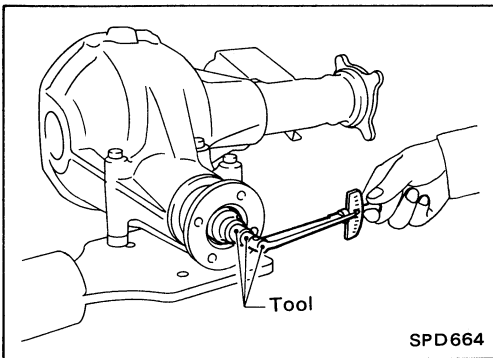

Pre-inspection

Before disassembling final drive, perform the following inspection.

- Total preload
 - 1) Turn drive pinion in both directions several times to set bearing rollers.
 - 2) Check total preload with Tool.

Tool number: ST3127S000 (See J25765-A)

Total preload:

1.23 - 2.30 N·m

(12.5 - 23.5 kg·cm, 10.9 - 20.4 in·lb)

- Ring gear to drive pinion backlash.
Check backlash of ring gear with a dial indicator at several points.

Ring gear-to-drive pinion backlash:

0.13 - 0.18 mm (0.0051 - 0.0071 in)

- Ring gear runout
Check runout of ring gear with a dial indicator.

Runout limit:

0.05 mm (0.0020 in)

- Tooth contact
Check tooth contact. (Refer to ADJUSTMENT.)

- Side gear to pinion mate gear backlash
Using a feeler gauge, measure clearance between side gear thrust washer and differential case.

**Clearance between side gear thrust washer
and differential case:**

0.10 - 0.20 mm (0.0039 - 0.0079 in)

Final Drive Housing

1. Using three spacers [20 mm (0.79 in)], mount final drive assembly on Tool.

Tool number:

KV38100800 (-)

Equivalent tool (J34310), (J25604)

DISASSEMBLY (Model R200A)

Final Drive Housing (Cont'd)

2. Remove differential side shaft assembly.

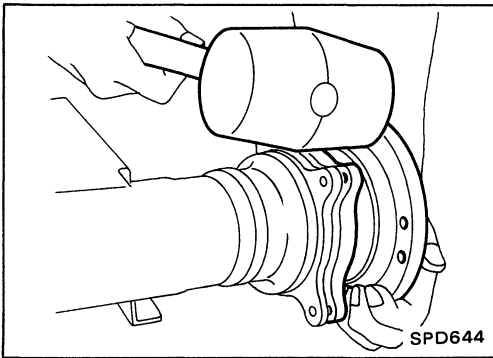

3. Remove differential side flange.

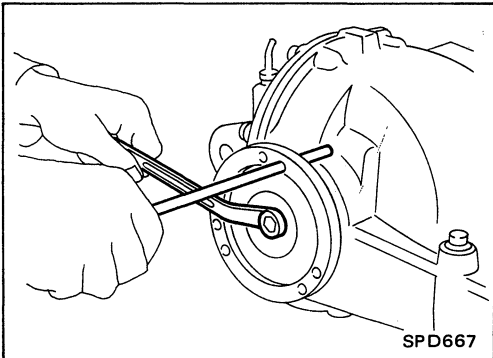

4. Put match marks on one side of side bearing cap with paint or punch to ensure that it is replaced in proper position during reassembly.

Bearing caps are line-bored during manufacture and should be put back in their original places.

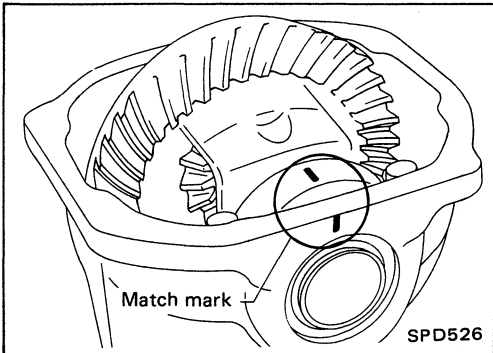

5. Remove side bearing caps.

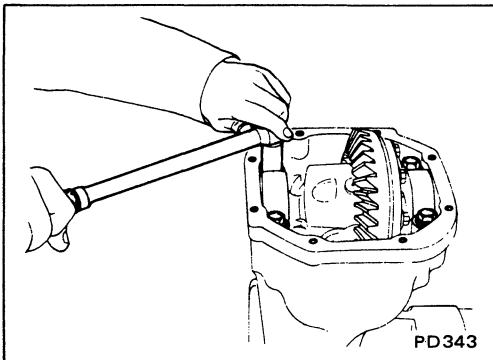

6. Remove differential case assembly with a pry bar.

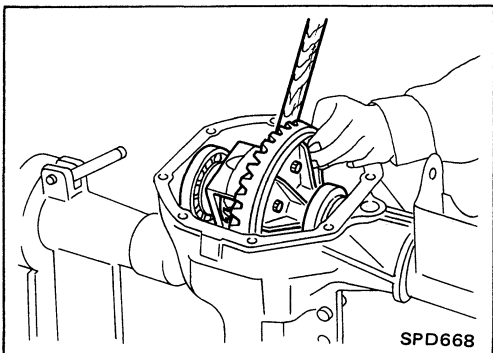

DISASSEMBLY (Model R200A)

Final Drive Housing (Cont'd)

Be careful to keep the side bearing outer races together with their respective inner cones – don't mix them up.

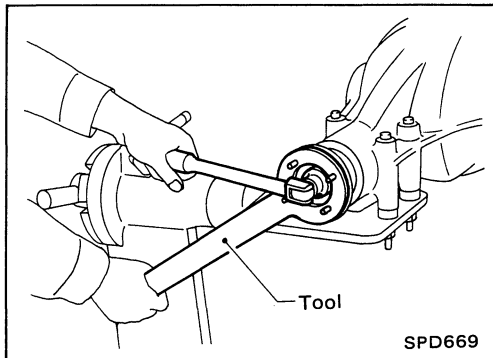
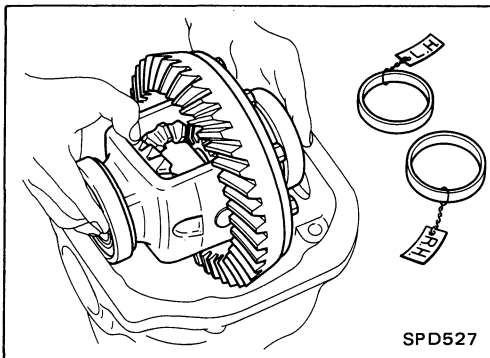

7. Loosen pinion nut.
Tool number: ST38060002 (J34311)

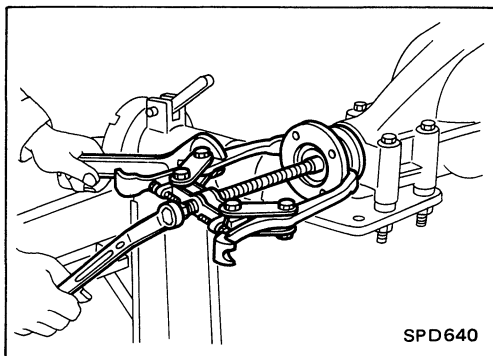

8. Remove companion flange with puller.

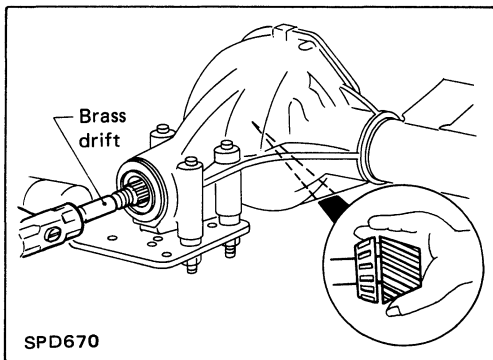

9. Take out drive pinion together with rear bearing inner cone, drive pinion bearing spacer and pinion bearing adjusting washer.
10. Remove front oil seal and pinion front bearing inner cone.

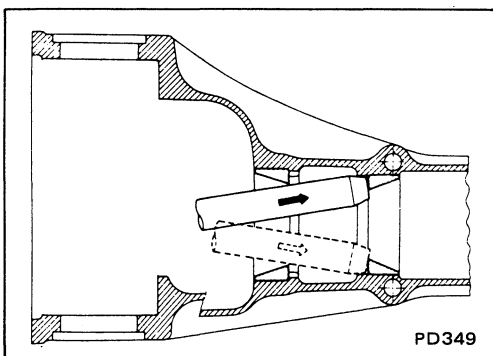

11. Remove pinion bearing outer races with a brass drift.

DISASSEMBLY (Model R200A)

Final Drive Housing (Cont'd)

12. Remove pinion rear bearing inner cone and drive pinion height adjusting washer.

Tool number: ST30031000 (J22912-01)

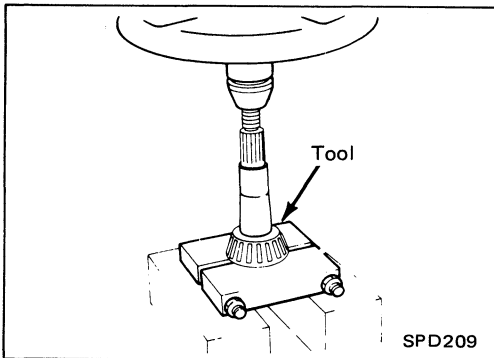

Differential Case

1. Remove side bearing inner cones.
To prevent damage to bearing, engage puller jaws in grooves.

Tool number:

- Ⓐ ST33051001 (-)
Equivalent tool (J22888)
- Ⓑ ST33061000 (J8107-2)

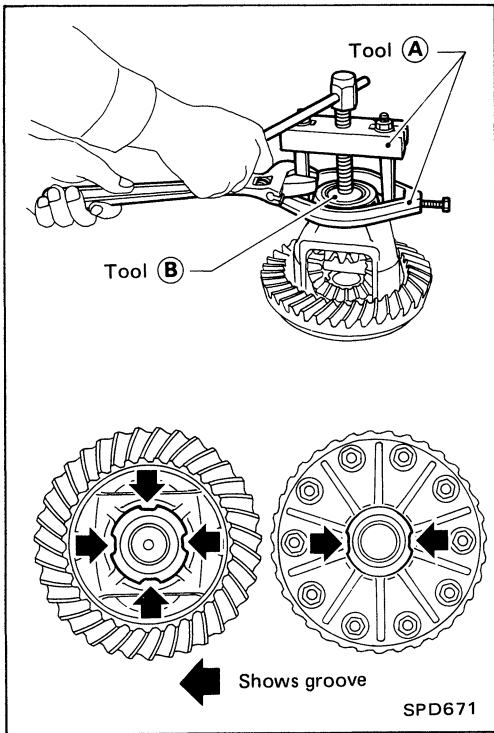

Be careful not to confuse the right and left hand parts.

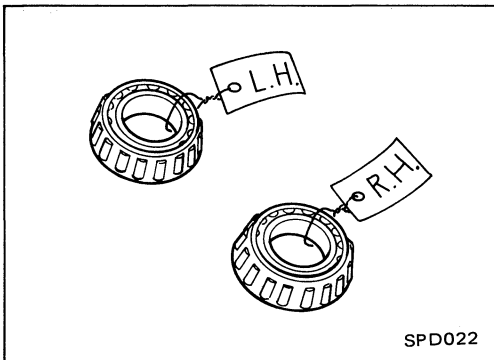

2. Loosen ring gear bolts in a criss-cross fashion.
3. Tap ring gear off the differential case with a soft hammer.
Tap evenly all around to keep ring gear from binding.

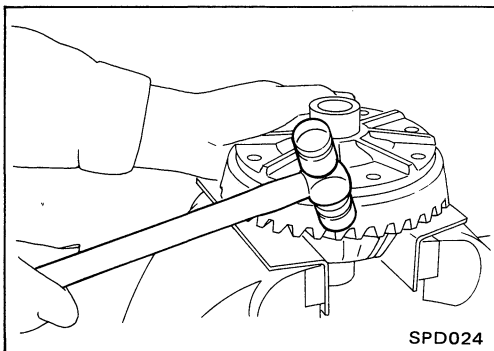

DISASSEMBLY (Model R200A)

Differential Case (Cont'd)

4. Punch off pinion mate shaft lock pin from ring gear side.

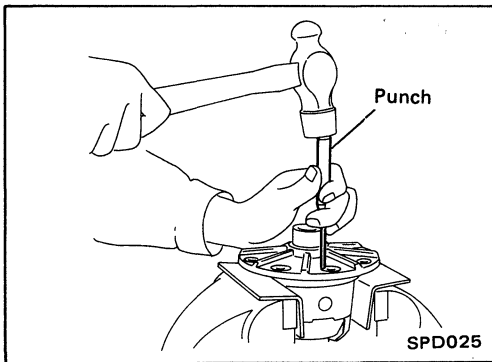

Differential Side Shaft

1. Cut collar with cold chisel. Be careful not to damage differential side shaft.

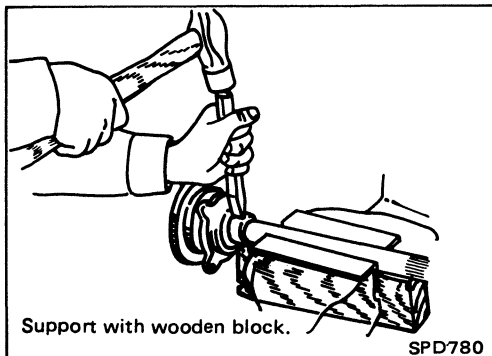

2. Reinstall differential side shaft into extension tube and secure with bolts. Remove rear axle bearing by drawing out differential side shaft from rear axle bearing with puller.

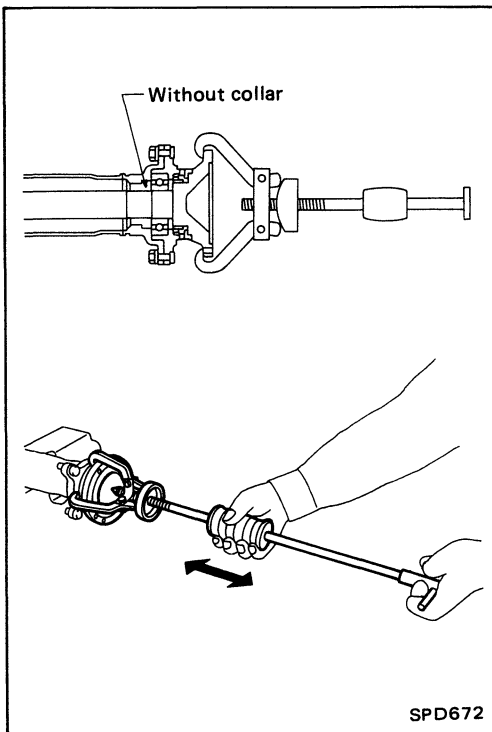

DISASSEMBLY (Model R200A)

Differential Side Shaft (Cont'd)

3. Remove grease seal and oil seal.

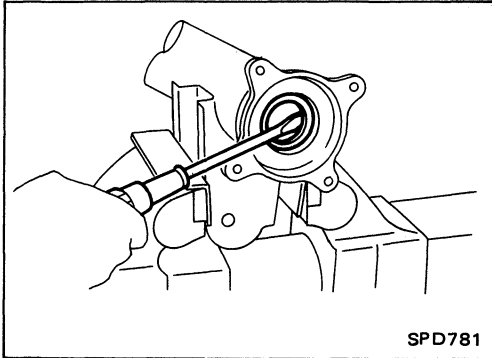
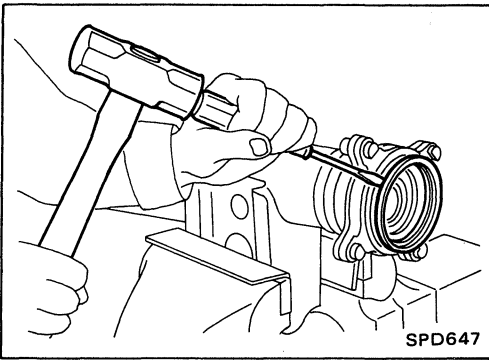

Ring Gear and Drive Pinion

Check gear teeth for scoring, cracking or chipping.

If any damaged part is evident, replace ring gear and drive pinion as a set (hypoid gear set).

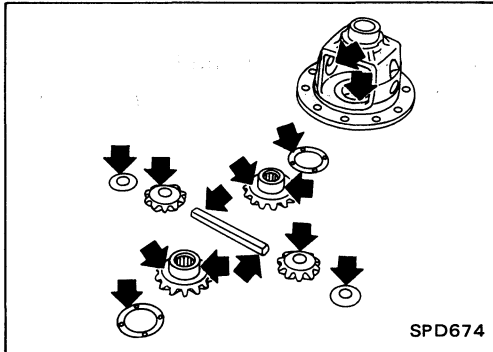

Differential Case Assembly

Check mating surfaces of differential case, side gears, pinion mate gears, pinion mate shaft, and thrust washers.

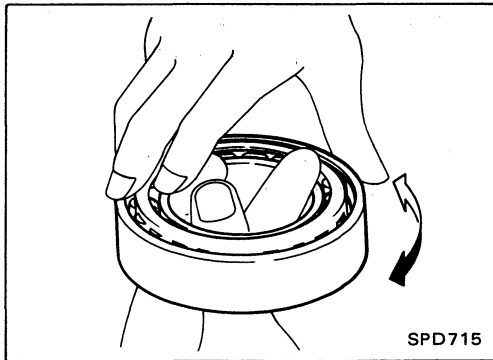

Bearing

1. Thoroughly clean bearing.
2. Check bearings for wear, scratches, pitting or flaking.
Check tapered roller bearing for smooth rotation. If damaged, replace outer race and inner cone as a set.

ADJUSTMENT (Model R200A)

For quiet and reliable final drive operation, the following five adjustments must be made correctly:

1. Side Bearing Preload.
2. Pinion Gear Height.
3. Pinion Bearing Preload.
4. Ring Gear-to-pinion Backlash. (Refer to ASSEMBLY.)
5. Ring and Pinion Gear Tooth Contact Pattern.

Side Bearing Preload

Note: A selection of carrier side bearing preload shims is required for successful completion of this procedure.

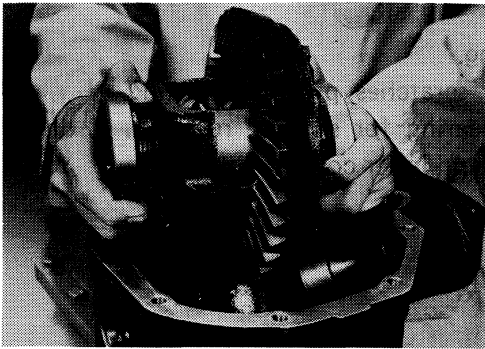

1. Make sure all parts are clean and that the bearings are well lubricated with light oil or Dexron type automatic transmission fluid.
2. Place the differential carrier, with side bearings and bearing races installed, into the final drive housing.

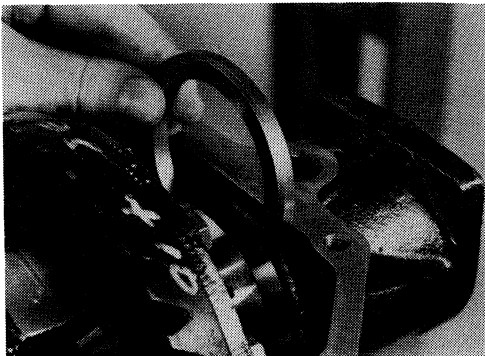

3. Put the side bearing spacer in place on the ring gear end of the carrier.

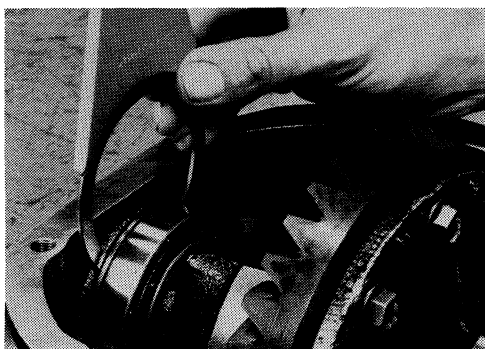

4. Using the J-25267 side bearing shim installer, place both of the original carrier side bearing preload shims on the carrier end, opposite the ring gear.

ADJUSTMENT (Model R200A)

Side Bearing Preload (Cont'd)

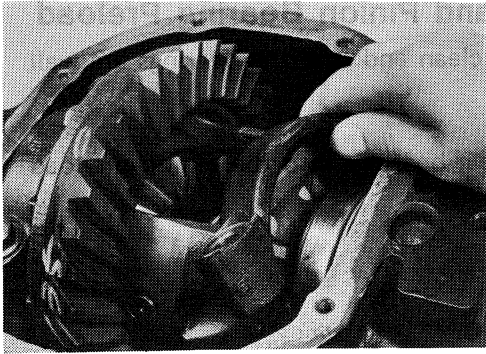

5. Install the side bearing caps in their correct locations and torque the bearing cap retaining bolts.

Specification: 88 - 98 N-m
(9 - 10 kg-m, 65 - 72 ft-lb)

6. Turn the carrier several times to seat the bearings.

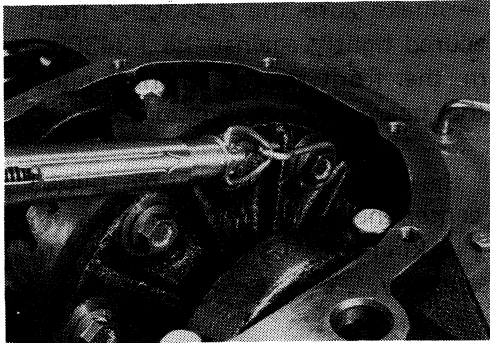

7. Measure the turning torque of the carrier at the ring gear retaining bolts with a spring gauge, J-8129.

Specification: 34.3 - 39.2 N
(3.5 - 4 kg, 7.7 - 8.8 lb)
of pulling force at the ring gear bolt.

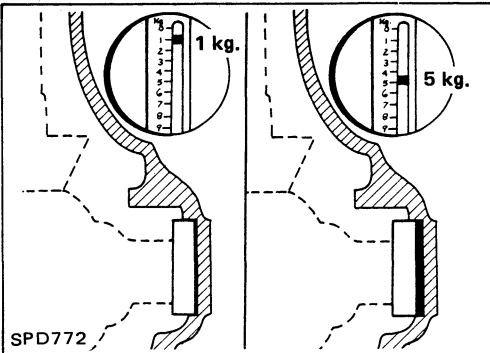

8. If the carrier turning torque is not within the specification range, increase or decrease the *total* thickness of the side bearing adjusting washers until the turning torque is correct. If the turning torque is less than the specified range, install washers of greater thickness; if the turning torque is greater than the specification, install thinner washers. See the S.D.S. section for washer dimensions and part numbers.

9. Record the total amount of washer thickness required for the correct carrier side bearing preload.

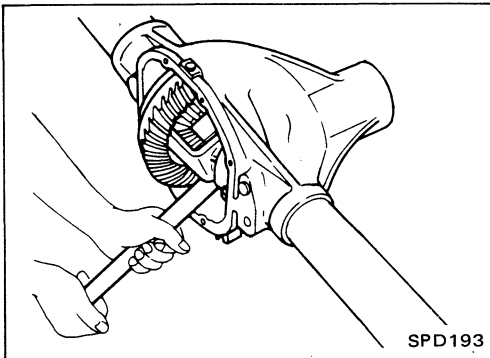

10. Remove the carrier from the final drive housing, saving the selected preload washers for later use during the assembly of the final drive unit.

ADJUSTMENT (Model R200A)

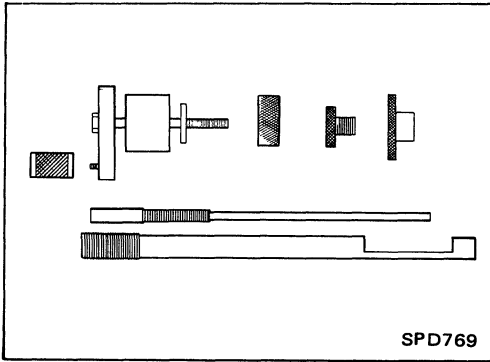

Pinion Gear Height and Pinion Bearing Preload

1. Make sure all parts are clean and that the bearings are well lubricated.
2. Assemble the pinion gear bearings into the pinion pre-load shim selector Tool, J-34309.

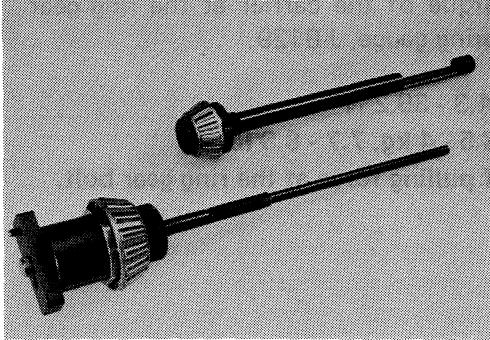

- **Front Pinion Bearing** — make sure the J-34309-3 front pinion bearing seat is secured tightly against the J-34309-2 gauge anvil. Then turn the front pinion bearing pilot, J-34309-5, to secure the bearing in its proper position.
- **Rear Pinion Bearing** — the rear pinion bearing pilot, J-34309-15, is used to center the rear pinion bearing only. The rear pinion bearing locking seat, J-34309-4, is used to lock the bearing to the assembly.

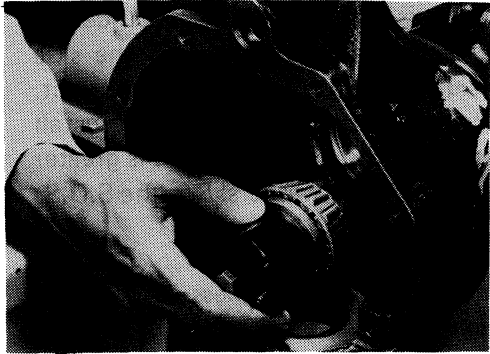

3. Place the pinion preload shim selector Tool, J-34309-1, gauge screw assembly with the pinion rear bearing inner cone installed into the final drive housing.

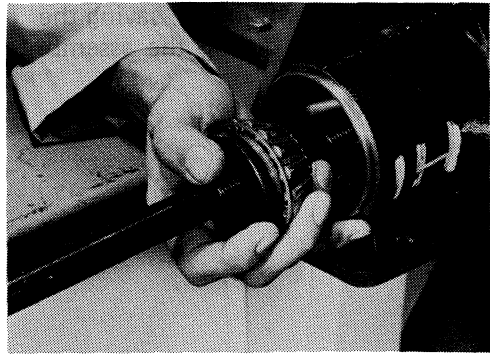

4. Assemble the front pinion bearing inner cone and the J-34309-2 gauge anvil together with the J-34309-1 gauge screw in the final drive housing. Make sure that the pinion height gauge plate, J-34309-16, will turn a full 360 degrees, and tighten the two sections together by hand.

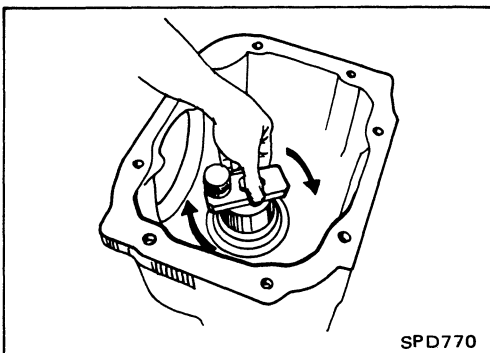

5. Turn the assembly several times to seat the bearings.

ADJUSTMENT (Model R200A)

Pinion Gear Height and Pinion Bearing Preload (Cont'd)

6. Measure the turning torque at the end of the J-34309-2 gauge anvil using torque wrench J-25765A.

Turning torque specification:

1.0 - 1.3 N·m (10 - 13 kg·cm, 8.7 - 11.3 in·lb)

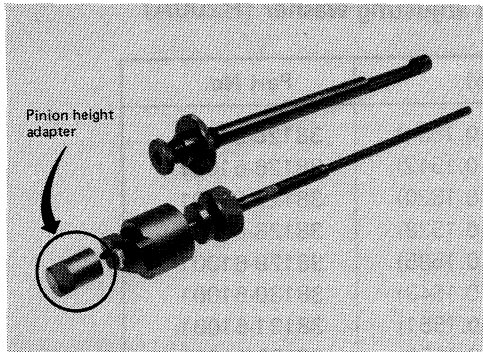
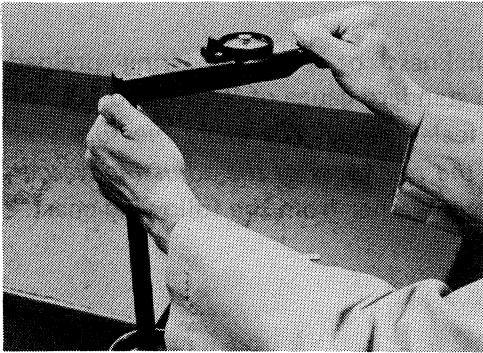

7. Place the J-34309-11 "R200A" pinion height adapter onto the gauge plate and tighten it by hand.

CAUTION:

Make sure all machined surfaces are clean.



PINION BEARING PRELOAD WASHER SELECTION

8. Place the solid pinion bearing spacer, small end first, over the J-34309-2 gauge anvil and seat the small end squarely against the tip of the J-34309-1 gauge screw in the tool recessed portion.

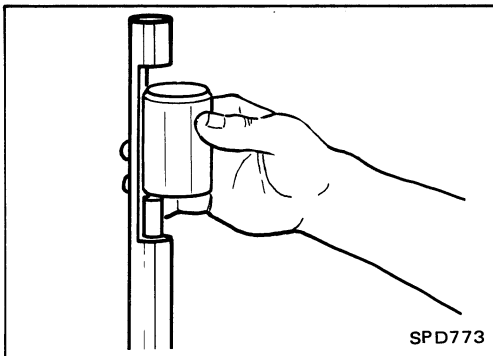

ADJUSTMENT (Model R200A)

Pinion Gear Height and Pinion Bearing Preload (Cont'd)

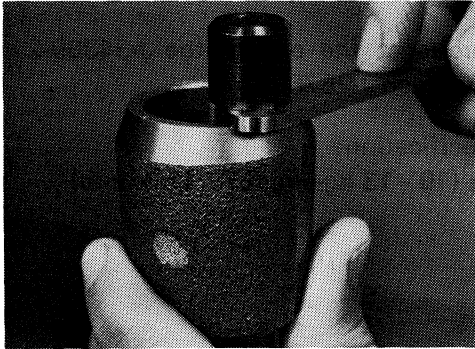

9. Select the correct thickness of pinion bearing preload adjusting washer using a standard gauge of 3.5 mm (0.138 in) and your J-34309-101 feeler gauge. *The exact measure you get with your gauges is the thickness of the adjusting washer required.* Select the correct washer from the following chart.

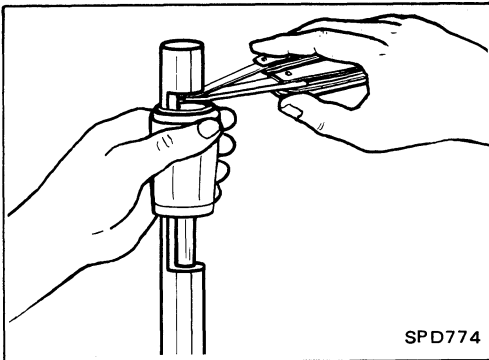

Drive pinion bearing preload adjusting washer (R200A)

Thickness mm (in)	Part No.
3.80 - 3.82 (0.1496 - 0.1504)	38125-61001
3.82 - 3.84 (0.1504 - 0.1512)	38126-61001
3.84 - 3.86 (0.1512 - 0.1520)	38127-61001
3.86 - 3.88 (0.1520 - 0.1528)	38128-61001
3.88 - 3.90 (0.1528 - 0.1535)	38129-61001
3.90 - 3.92 (0.1535 - 0.1543)	38130-61001
3.92 - 3.94 (0.1543 - 0.1551)	38131-61001
3.94 - 3.96 (0.1551 - 0.1559)	38132-61001
3.96 - 3.98 (0.1559 - 0.1567)	38133-61001
3.98 - 4.00 (0.1567 - 0.1575)	38134-61001
4.00 - 4.02 (0.1575 - 0.1583)	38135-61001
4.02 - 4.04 (0.1583 - 0.1591)	38136-61001
4.04 - 4.06 (0.1591 - 0.1598)	38137-61001
4.06 - 4.08 (0.1598 - 0.1606)	38138-61001
4.08 - 4.10 (0.1606 - 0.1614)	38139-61001

10. Set your selected, correct pinion bearing preload adjusting washer aside for use when assembling the pinion gear and bearings into the final drive.

PINION HEIGHT ADJUSTING WASHER SELECTION

11. Now, position the side bearing discs, J-25269-4, and arbor firmly into the side bearing bores.

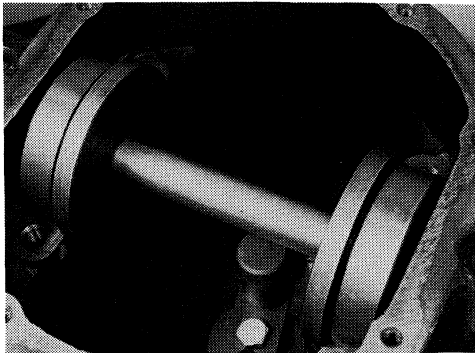

12. Install the side bearing caps and torque the cap bolts.

Specification: 88 - 98 N·m
(9 - 10 kg·m, 65 - 72 ft·lb)

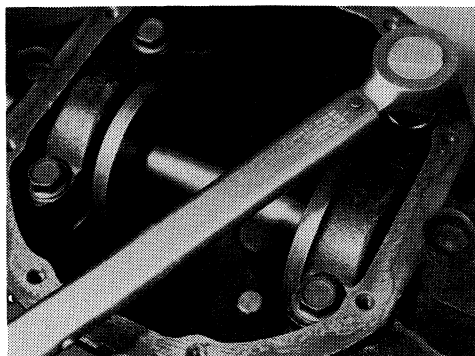

ADJUSTMENT (Model R200A)

Pinion Gear Height and Pinion Bearing Preload (Cont'd)

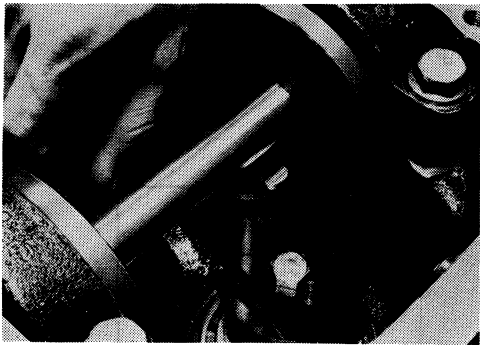

13. Select the correct *standard* pinion height adjusting washer thickness by using a standard gauge of 3.0 mm (0.118 in) and your J-34309-101 feeler gauge. Measure the gap between the J-34309-11 "R200A" pinion height adapter and the arbor.

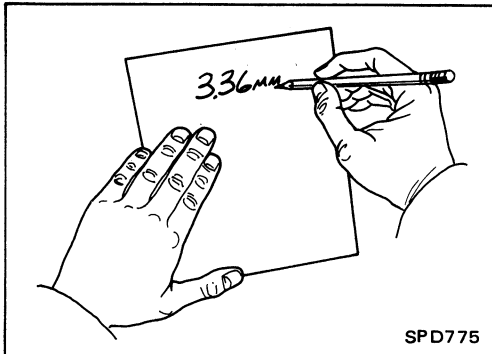

14. Write down your exact total measurement.

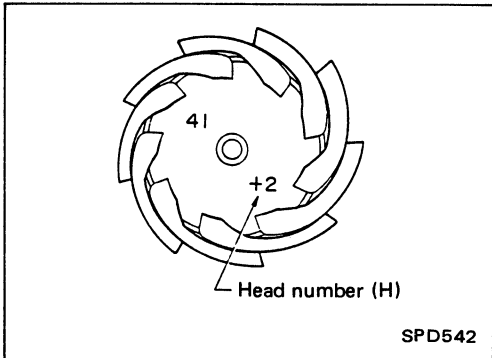

15. Correct the pinion height washer size by referring to the "pinion head number."

Note: There are two numbers painted on the pinion gear. The first one refers to the pinion and ring gear as a matched set and should be the same as the number on the ring gear. The second number is the "pinion head height number," and it refers to the ideal pinion height from standard for the quietest operation.

Use the following chart to determine the correct pinion height washer.

Pinion Head Height Number	Add or Remove from the Standard Pinion Height Washer Thickness Measurement
-6	Add 0.06 mm (0.0024 in)
-5	Add 0.05 mm (0.0020 in)
-4	Add 0.04 mm (0.0016 in)
-3	Add 0.03 mm (0.0012 in)
-2	Add 0.02 mm (0.0008 in)
-1	Add 0.01 mm (0.0004 in)
0	Use the selected washer thickness
+1	Subtract 0.01 mm (0.0004 in)
+2	Subtract 0.02 mm (0.0008 in)
+3	Subtract 0.03 mm (0.0012 in)
+4	Subtract 0.04 mm (0.0016 in)
+5	Subtract 0.05 mm (0.0020 in)
+6	Subtract 0.06 mm (0.0024 in)

ADJUSTMENT (Model R200A)

Pinion Gear Height and Pinion Bearing Preload (Cont'd)

Select the correct pinion height washer from the following chart.

Drive pinion height adjusting washer (R200A)

Thickness mm (in)	Part No.
3.09 (0.1217)	38154-P6017
3.12 (0.1228)	38154-P6018
3.15 (0.1240)	38154-P6019
3.18 (0.1252)	38154-P6020
3.21 (0.1264)	38154-P6021
3.24 (0.1276)	38154-P6022
3.27 (0.1287)	38154-P6023
3.30 (0.1299)	38154-P6024
3.33 (0.1311)	38154-P6025
3.36 (0.1323)	38154-P6026
3.39 (0.1335)	38154-P6027
3.42 (0.1346)	38154-P6028
3.45 (0.1358)	38154-P6029
3.48 (0.1370)	38154-P6030
3.51 (0.1382)	38154-P6031
3.54 (0.1394)	38154-P6032
3.57 (0.1406)	38154-P6033
3.60 (0.1417)	38154-P6034
3.63 (0.1429)	38154-P6035
3.66 (0.1441)	38154-P6036

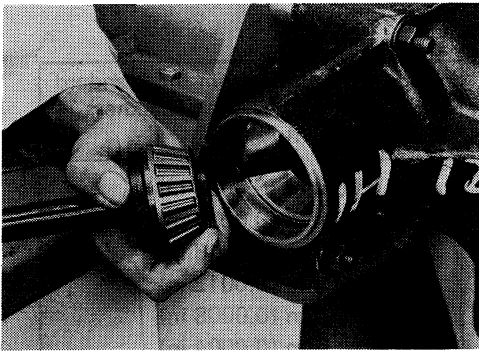

16. Remove the J-34309 pinion preload shim selector tool from the final drive housing and disassemble to retrieve the pinion bearings.

ADJUSTMENT (Model R200A)

Tooth Contact

Gear tooth contact pattern check is necessary to verify correct relationship between ring gear and drive pinion.

Hypoid gear sets which are not positioned properly in relation to one another may be noisy, or have short life, or both. With a pattern check, the most desirable contact for low noise level and long life can be assured.

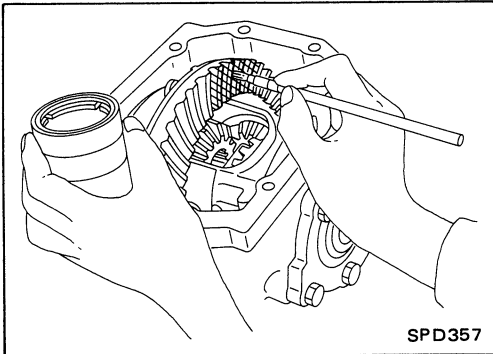

1. Thoroughly clean ring gear and drive pinion teeth.
2. Sparingly apply a mixture of powdered ferric oxide and oil or equivalent to 3 or 4 teeth of ring gear drive side.

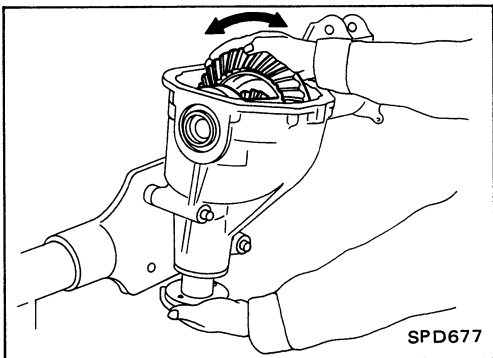

3. Hold companion flange steady by hand and rotate the ring gear in both directions.

Usually the pattern will be correct if you have calculated the shims correctly and the backlash is correct. However, in rare cases you may have to use trial-and-error processes until you get a good tooth contact pattern. The tooth pattern is the best indication of how well a differential has been set up.

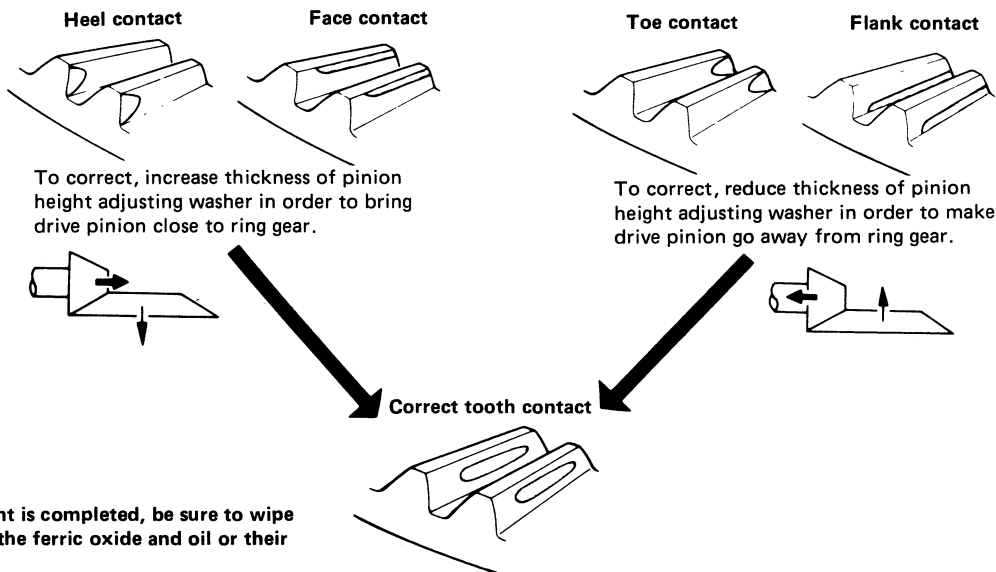

When adjustment is completed, be sure to wipe off completely the ferric oxide and oil or their equivalent.

SPD007

Differential Side Shaft

1. Measure rear axle bearing end play.

Rear axle bearing end play (A – B):

0.1 mm (0.0039 in) or less

The end play can be adjusted with bearing adjusting shim.
(Refer to S.D.S.)

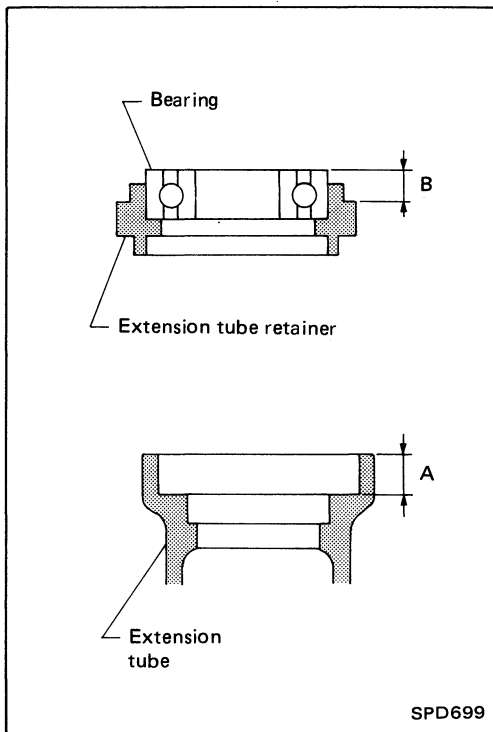

2. Install oil seal and grease seal.

Tool number: ST33190000 (-)

Equivalent tool (J26233)

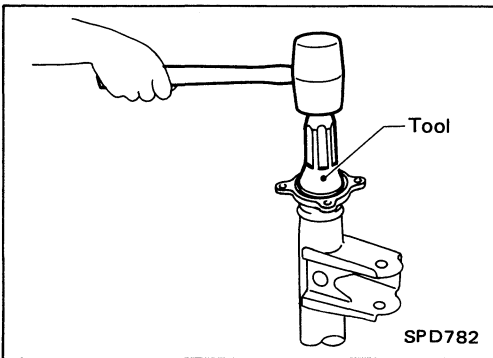

Tool number: (J26233)

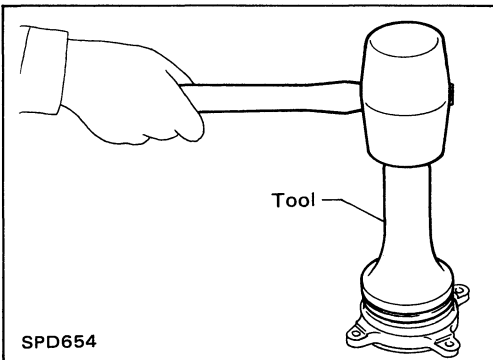

3. Install extension tube retainer, rear axle bearing and rear axle shaft bearing collar on differential side shaft.

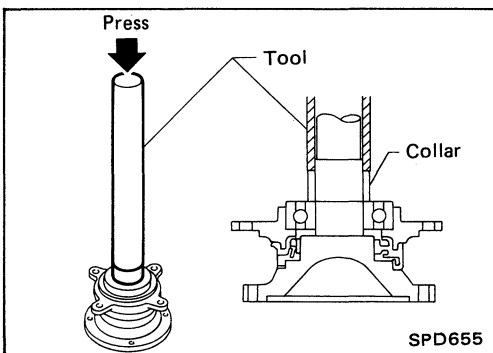

ASSEMBLY (Model R200A)

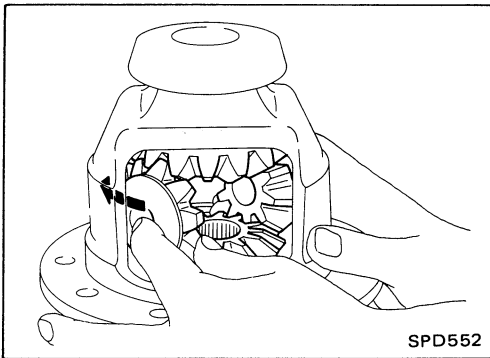

Differential Case

1. Install side gears, pinion mate gears, thrust washers and thrust block into differential case.

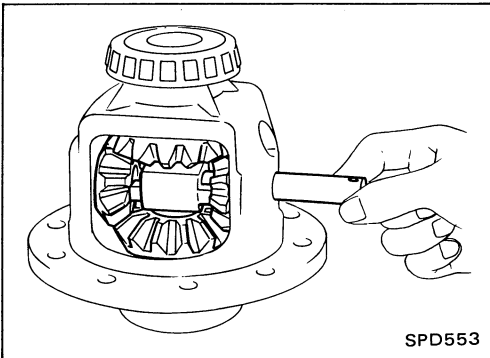

2. Fit pinion mate shaft to differential case so that it meets lock pin holes.

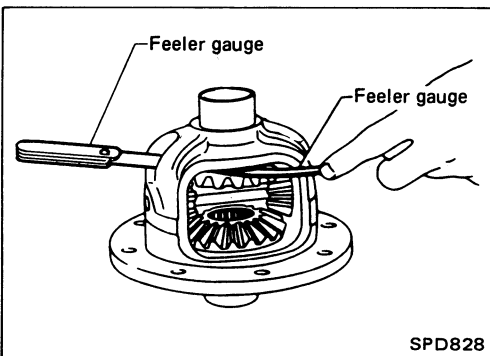

3. Adjust clearance between rear face of side gear and thrust washer by selecting side gear thrust washer. (Refer to S.D.S.)

Clearance between side gear thrust washer and differential case:

0.10 - 0.20 mm (0.0039 - 0.0079 in)

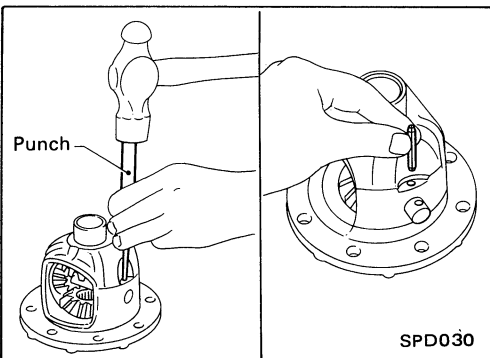

4. Install pinion mate shaft lock pin with a punch. **Make sure lock pin is flush with case.**

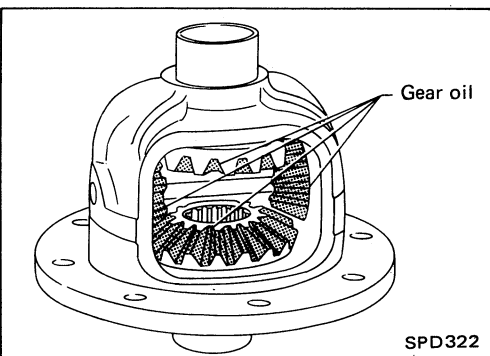

5. Apply gear oil to gear tooth surfaces and thrust surfaces and check to see they turn properly.

ASSEMBLY (Model R200A)

Differential Case (Cont'd)

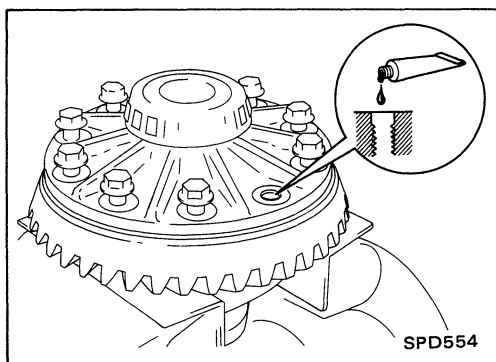

6. Place differential case on ring gear.
7. Apply locking agent [Locktite (stud lock) or equivalent] to ring gear bolts, and install them.

Tighten bolts in a criss-cross fashion, lightly tapping bolt head with a hammer.

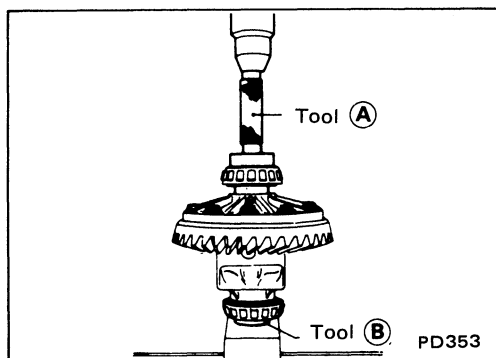

8. Press-fit side bearing inner cones on differential case with Tool.

Tool number:

- (A) KV38100300 (J25523)
- (B) ST33061000 (J8107-2)

Final Drive Housing

1. Press-fit front and rear bearing outer races with Tools.

Tool number:

- (A) ST30611000 (J25742-1)
- (B) ST30621000 (J25742-5)
- (C) ST30613000 (J25742-3)

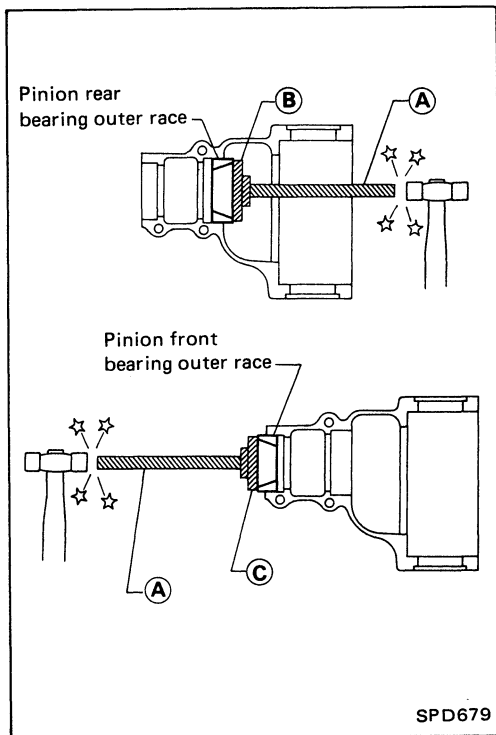

2. Select drive pinion height adjusting washer and pinion bearing adjusting washer, referring to ADJUSTMENT.
3. Install drive pinion height adjusting washer in drive pinion, and press-fit pinion rear bearing inner cone in it, using press and Tool.

Tool number: ST30901000 (-)
Equivalent tool (J26010-01)

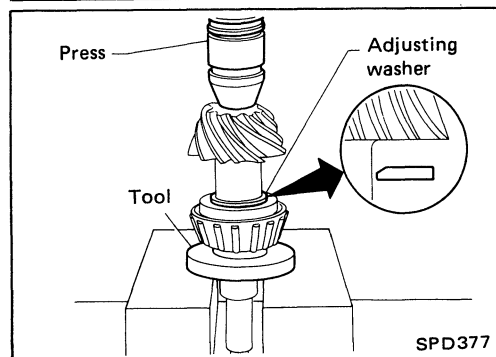

ASSEMBLY (Model R200A)

Final Drive Housing (Cont'd)

- Place pinion front bearing inner cone in final drive housing.

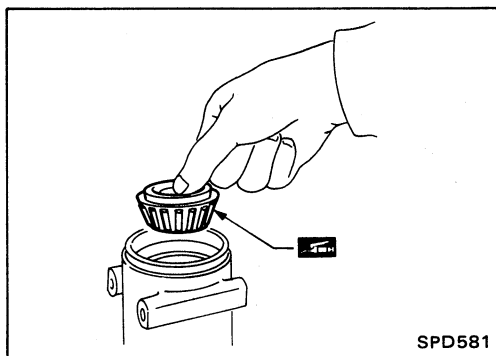

- Apply multi-purpose grease to cavity at sealing lips of oil seal. Install front oil seal.

Tool number: KV38100500 (-)

Equivalent tool (J25273)

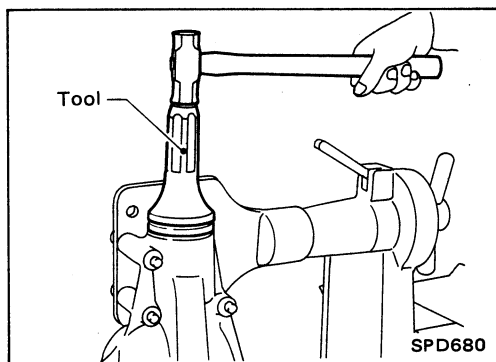

- Place drive pinion bearing spacer, drive pinion bearing adjusting washer and drive pinion in final drive housing.

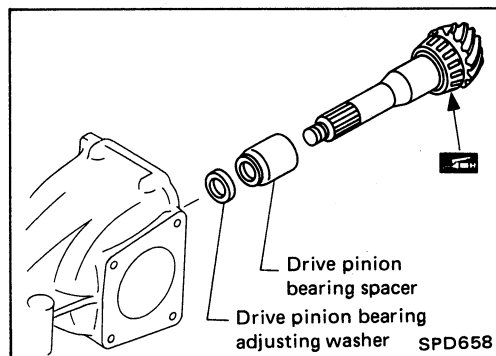

- Insert companion flange into drive pinion by tapping the companion flange with a soft hammer.

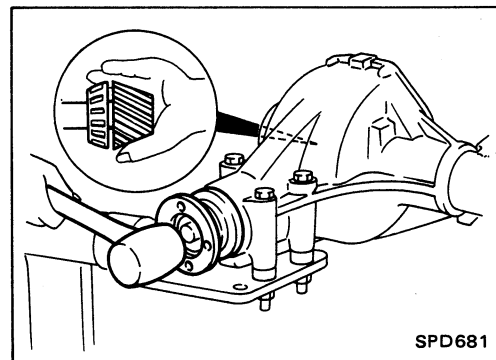

- Tighten pinion nut to the specified torque. The threaded portion of drive pinion and pinion nut should be free from oil or grease.

Tool number: ST38060002 (J34311)

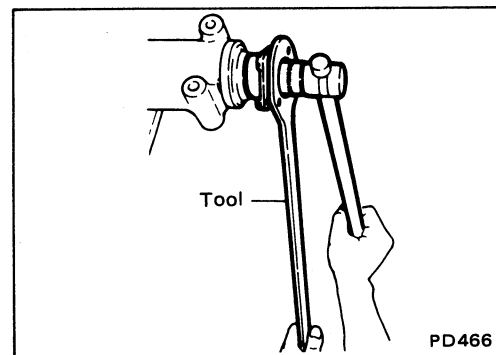

ASSEMBLY (Model R200A)

Final Drive Housing (Cont'd)

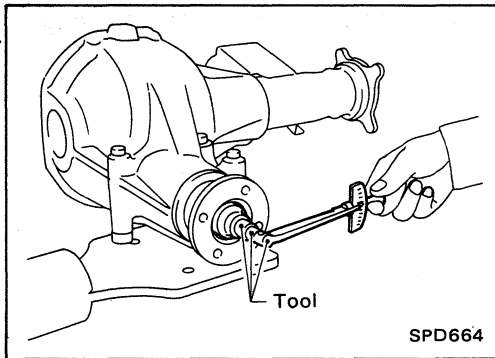

9. Turn drive pinion in both directions several revolutions, and measure pinion bearing preload.

Tool number: ST3127S000 (See J25765-A)

Pinion bearing preload:

1.13 - 1.72 N·m

(11.5 - 17.5 kg·cm, 10.0 - 15.2 in·lb)

When pinion bearing preload is outside the specifications, replace pinion bearing adjusting washer and spacer with a different thickness.

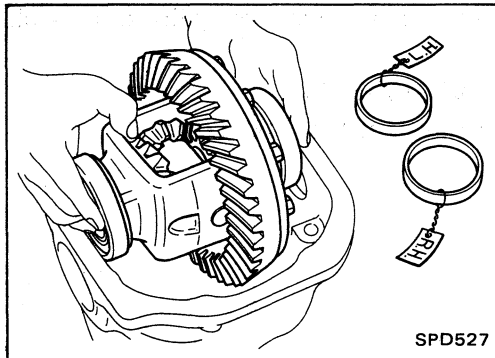

10. Select side bearing adjusting washer.

Refer to ADJUSTMENT.

11. Install differential case assembly with side bearing outer races into final drive housing.

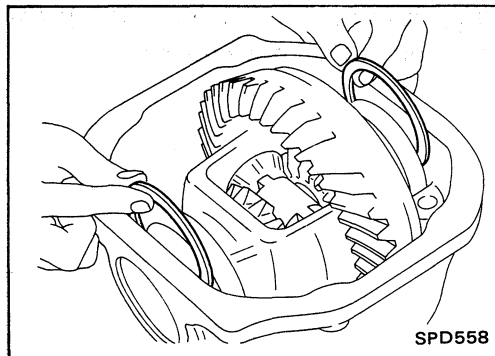

12. Insert left and right side bearing adjusting washers in place between side bearings and final drive housing.

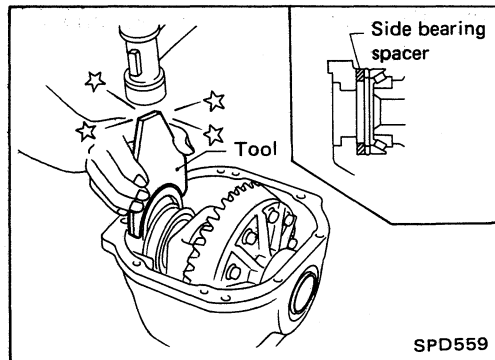

13. Drive in side bearing spacer with Tool.

Tool number: KV38100600 (J25267)

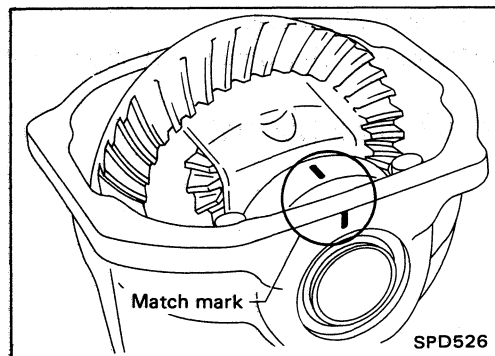

14. Align mark on bearing cap with that on final drive housing and install bearing cap on final drive housing.

ASSEMBLY (Model R200A)

Final Drive Housing (Cont'd)

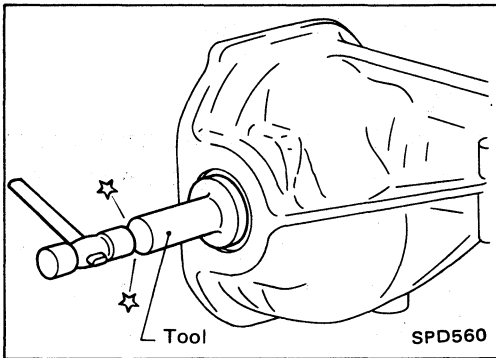

15. Apply multi-purpose grease to cavity at sealing lips of oil seal. Install side oil seal.

Tool number: KV38100200 (J26233)

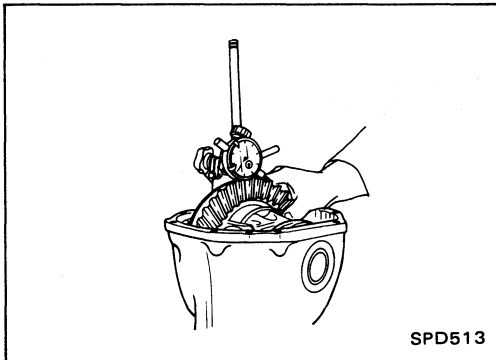

16. Measure ring gear-to-drive pinion backlash with a dial indicator.

Ring gear-to-drive pinion backlash:

0.13 - 0.18 mm (0.0051 - 0.0071 in)

- If backlash is too small, decrease thickness of right shim and increase thickness of left shim by the same amount.

If backlash is too great, reverse the above procedure.

Never change the total amount of shims as it will change the bearing preload.

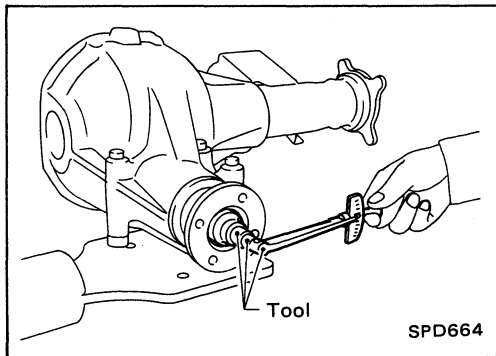

17. Check total preload with Tool.

When checking preload, turn drive pinion in both directions several times to set bearing rollers.

Tool number: ST3127S000 (See J25765-A)

Total preload:

1.23 - 2.30 N·m

(12.5 - 23.5 kg·cm, 10.9 - 20.4 in·lb)

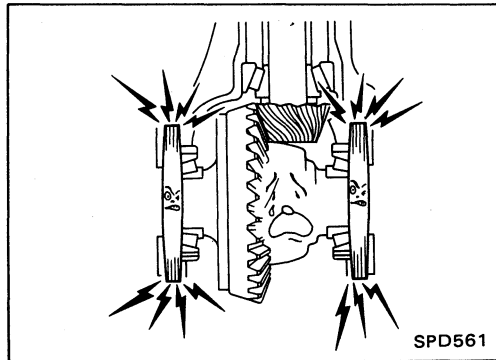

- If preload is too great, remove the same amount of shim from each side.
- If preload is too small, add the same amount of shim to each side.

Never add or remove a different number of shims for each side as it will change ring gear-to-drive pinion backlash.

18. Recheck ring gear-to-drive pinion backlash because increase or decrease in thickness of shims will cause change of ring gear-to-pinion backlash.

ASSEMBLY (Model R200A)

Final Drive Housing (Cont'd)

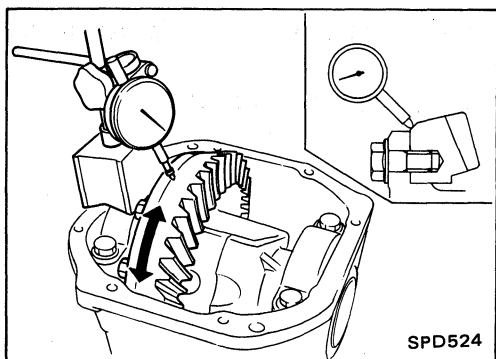

19. Check runout of ring gear with a dial indicator.

Runout limit:

0.05 mm (0.0020 in)

- If backlash varies excessively in different places, the variance may have resulted from foreign matter caught between the ring gear and the differential case.
- If the backlash varies greatly when the runout of the ring gear is within a specified range, the hypoid gear set or differential case should be replaced.

20. Check tooth contact.

Refer to ADJUSTMENT.

21. Install rear cover and gasket.

22. Install differential side shaft assembly.

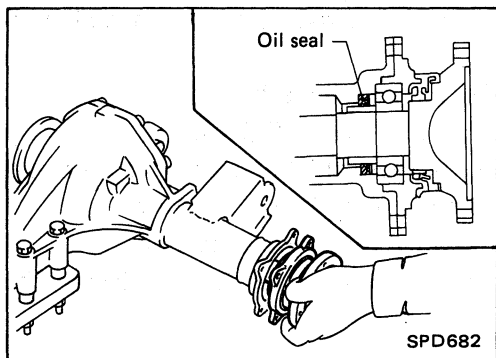

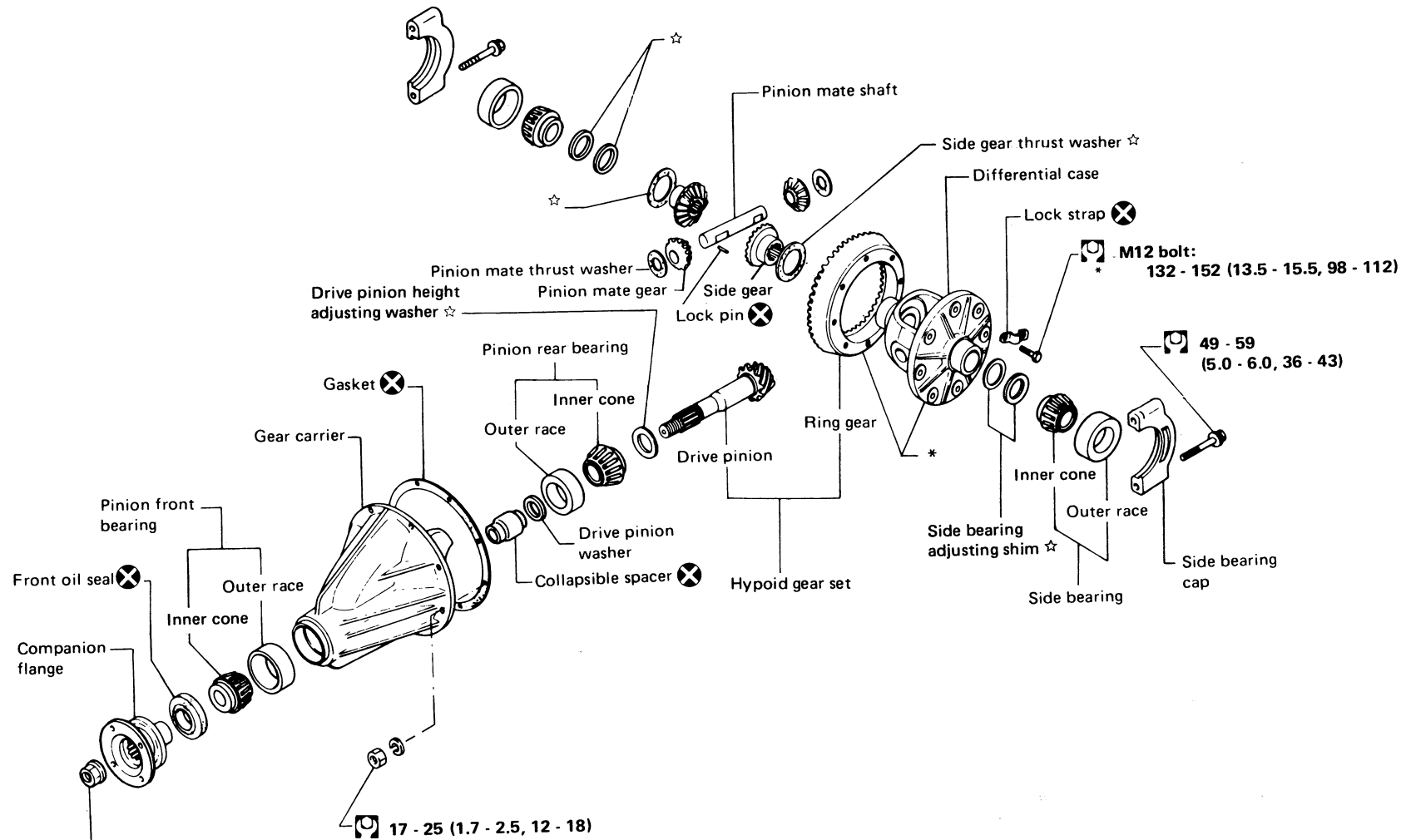

Tighten pinion nut until total preload of 1.2 - 2.2 N·m (12 - 22 kg·cm, 10 - 19 in·lb) is obtained.

- ⊗ : N·m (kg·m, ft·lb)
- ⊗ : Always replace.
- ☆ : Adjustment is required.
- * : Using locking agent [Loctite (stud lock) or equivalent]

DISASSEMBLY (Model H190A)

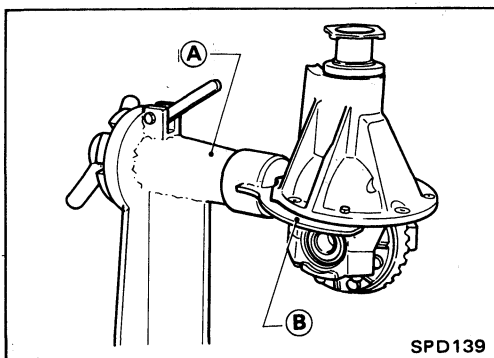
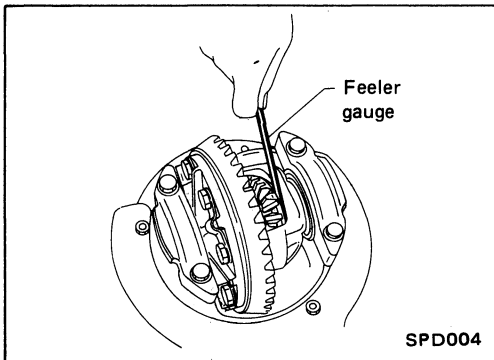
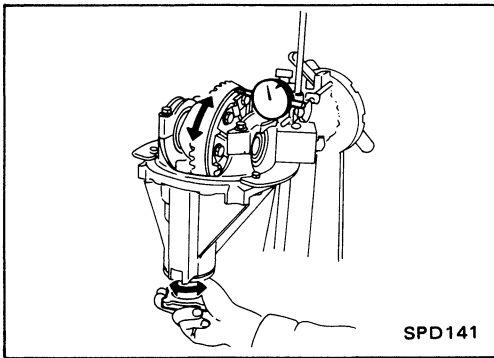
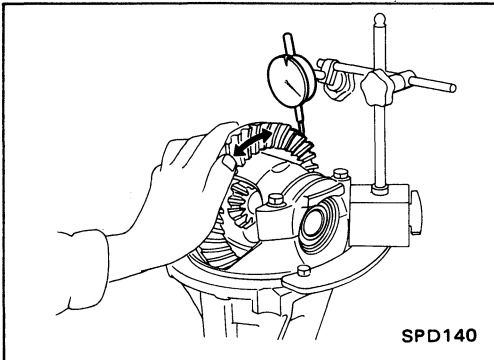
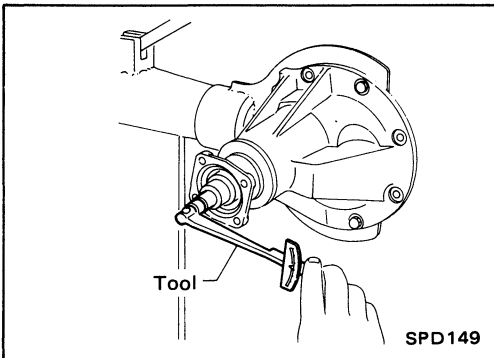

Pre-inspection

Before disassembling final drive, perform the following inspection.

- Total preload
 - 1) Turn drive pinion in both directions several revolutions to seat bearing rollers correctly.
 - 2) Check total preload with Tool.

Tool number: ST3127S000 (See J25765-A)

Total preload:

1.2 - 2.2 N·m

(12 - 22 kg·cm, 10 - 19 in·lb)

- Ring gear to drive pinion backlash
Check backlash of ring gear with a dial indicator at several points.

Ring gear-to-drive pinion backlash:

0.13 - 0.18 mm (0.0051 - 0.0071 in)

- Ring gear runout
Check runout of ring gear with a dial indicator.

Runout limit:

0.08 mm (0.0031 in)

- Tooth contact
Check tooth contact, referring to ADJUSTMENT.
- Side gear to pinion mate gear backlash
Measure clearance between side gear thrust washer and differential case with a feeler gauge.

Clearance between side gear thrust washer and differential case:

0.10 - 0.20 mm (0.0039 - 0.0079 in)

Differential Carrier

1. Mount differential carrier on Tools.

Tool number:

Ⓐ ST0501S000 (—)

Ⓑ ST06310000 (J25602-01)

DISASSEMBLY (Model H190A)

Differential Carrier (Cont'd)

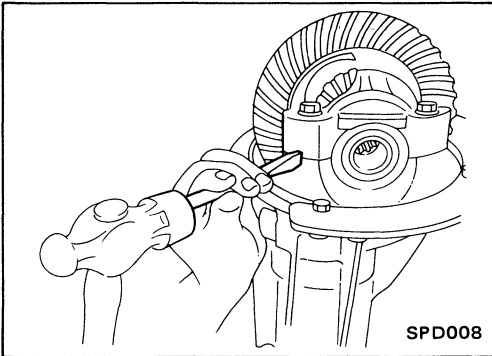

2. Put match marks on one side of side bearing cap with paint or punch to ensure that it is replaced in proper position during reassembly.

Bearing caps are line-bored during manufacture and should be put back in their original places.

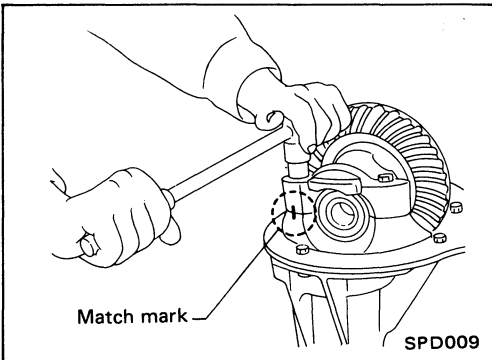

3. Remove side bearing caps.

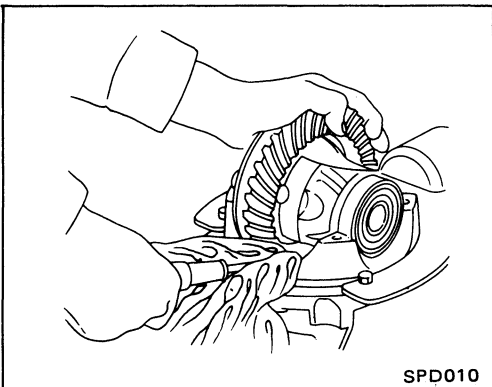

4. Remove differential case assembly with a pry bar. Be careful to keep the side bearing outer races together with their respective inner cones — do not mix them up.

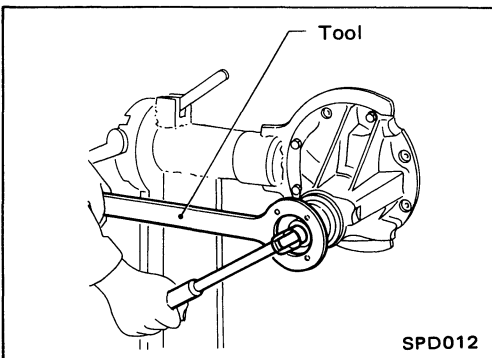
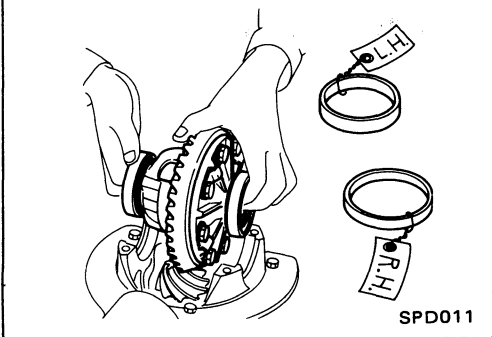

5. Remove drive pinion nut with Tool.
Tool number: ST38060002 (J34311)

DISASSEMBLY (Model H190A)

Differential Carrier (Cont'd)

6. Remove companion flange with puller.

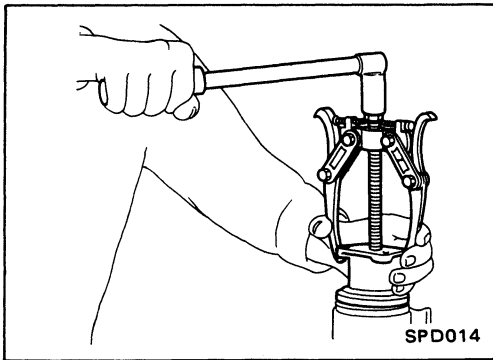

7. Remove drive pinion with soft hammer.

8. Remove oil seal.

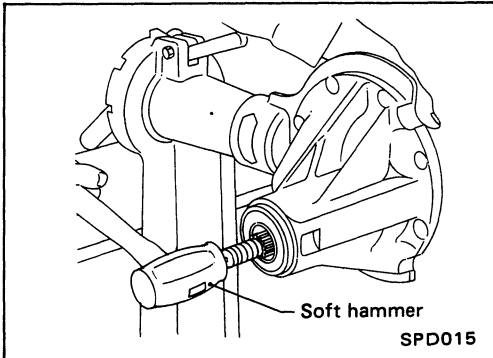

9. Remove pinion bearing outer races with a brass drift.

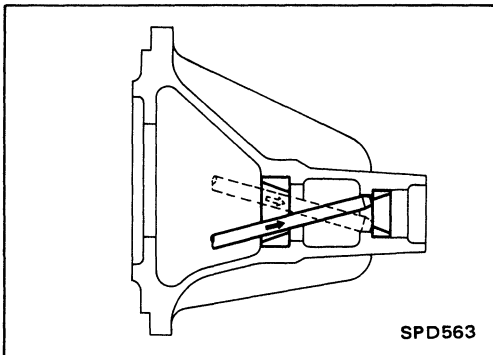

10. Pull out rear bearing inner cone with a press and Tool.
Tool number: ST30031000 (J22912-01)

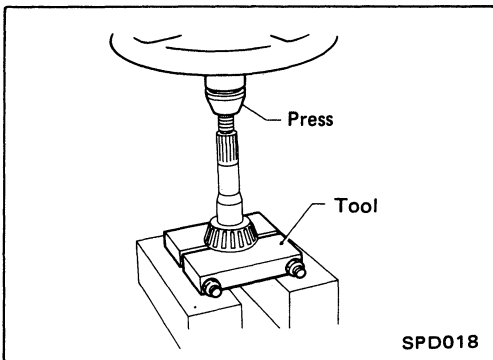

DISASSEMBLY (Model H190A)

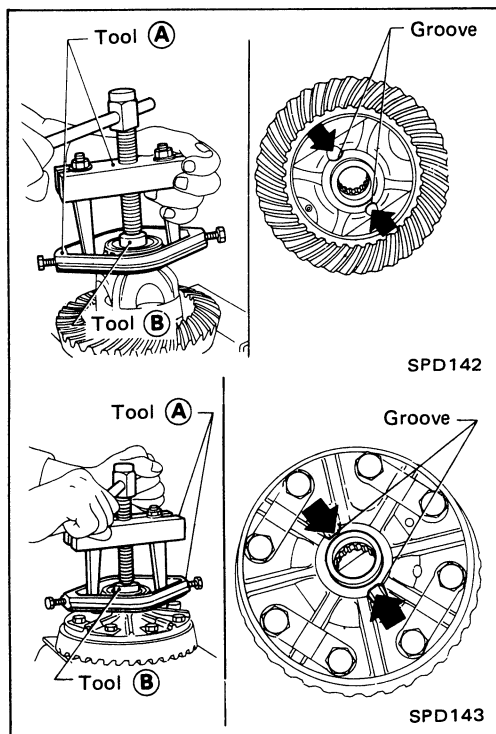

Differential Case

1. Remove side bearing inner cones.

To prevent damage to bearing, engage puller jaws in groove.

Tool number:

- Ⓐ ST33051001 (—)
Equivalent tool (J22888)
- Ⓑ ST33061000 (J8107-2)

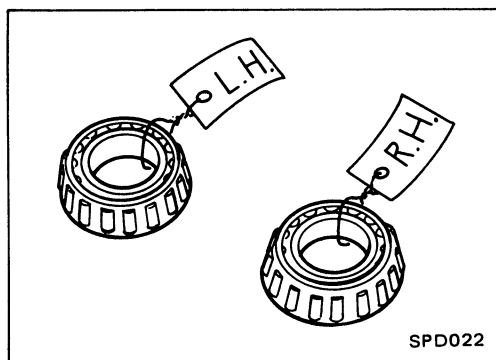

Be careful not to confuse left and right hand parts.

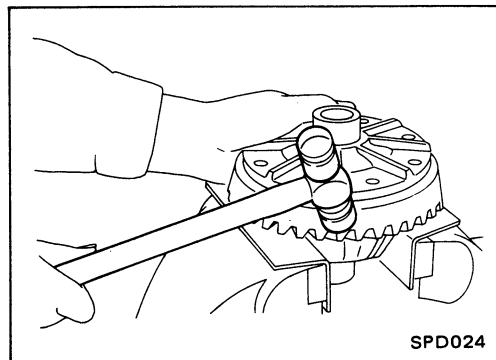

2. Spread out lock straps and loosen ring gear bolts in a criss-cross fashion.

3. Tap ring gear off differential case with a soft hammer.

Tap evenly all around to keep ring gear from binding.

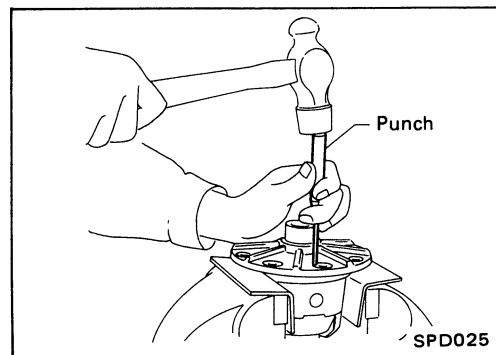

4. Drive out pinion mate shaft lock pin, with Tool from ring gear side.

Lock pin is called at pin hole mouth on differential case.

Ring Gear and Drive Pinion

Check gear teeth for scoring, cracking or chipping.
If any damaged part is evident, replace ring gear and drive pinion as a set (hypoid gear set).

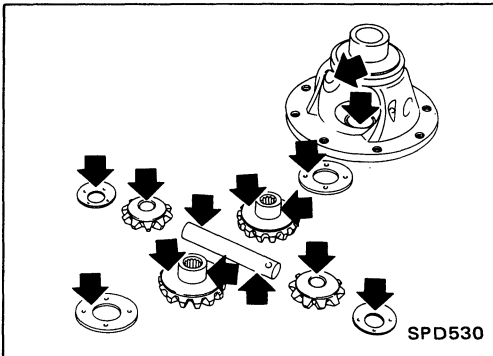

Differential Case Assembly

Check mating surfaces of differential case, side gears, pinion mate gears, pinion mate shaft, and thrust washers.

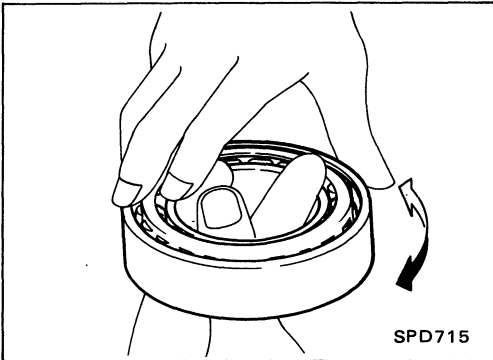

Bearing

1. Thoroughly clean bearing.
2. Check bearings for wear, scratches, pitting or flaking.
Check tapered roller bearing for smooth rotation. If damaged, replace outer race and inner cone as a set.

ADJUSTMENT (Model H190A)

For quiet and reliable final drive operation, the following five adjustments must be made correctly:

1. Side Bearing Preload.
2. Pinion Gear Height.
3. Pinion Bearing Preload. (Refer to ASSEMBLY.)
4. Ring Gear-to-pinion Backlash. (Refer to ASSEMBLY.)
5. Ring and Pinion Gear Tooth Contact Pattern.

Side Bearing Preload

NOTE:

A selection of carrier side bearing preload shims is required for successful completion of this procedure.

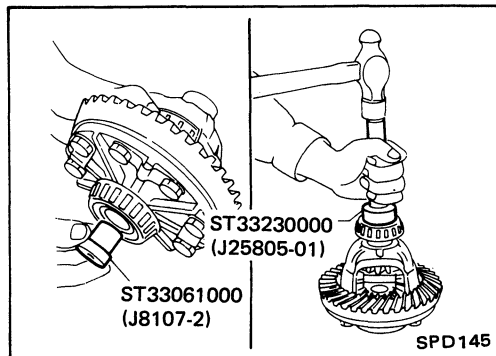
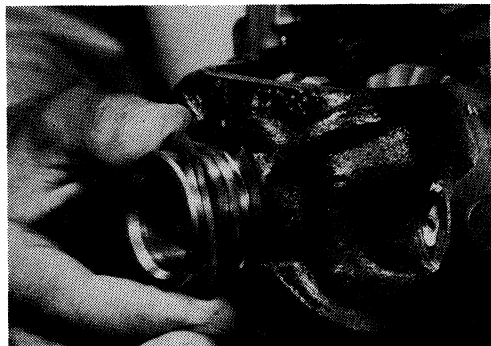
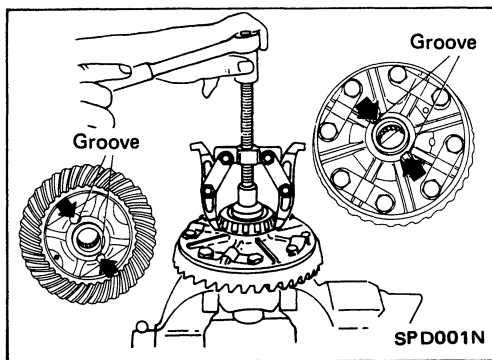

1. Make sure all parts are clean and that the bearings are well lubricated with light oil or Dexron type automatic transmission fluid.
2. Attach side bearing puller Tools J-22888 and J-8107-02 to the carrier side bearing and remove the bearings.
3. Reinstall all of the original side bearing adjusting shims on the carrier side, away from the ring gear.
4. Reinstall the carrier side bearing using Tools J-25805-01 and J-8107-2. Press on the bearings.

ADJUSTMENT (Model H190A)

Side Bearing Preload (Cont'd)

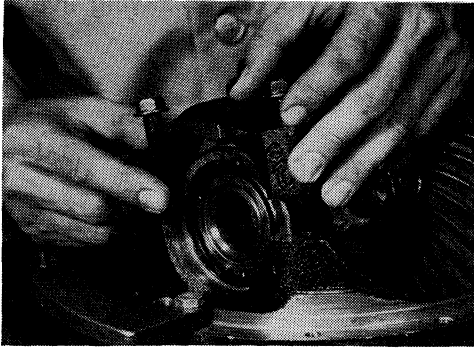

5. Install carrier and bearings into the final drive housing. Install side bearing caps. Torque the bolts and tap on the caps with a soft hammer to seat the bearings.

Side bearing cap bolt torque:

**Specification 49 - 59 N·m
(5 - 6 kg-m, 36 - 43 ft-lb)**

6. After turning the carrier several times to seat the bearings, measure carrier turning force with spring gauge J-8129.

Turning force specification:

**34.3 - 39.2 N (3.5 - 4.0 kg, 7.7 - 8.8 lb)
of pulling force at the ring gear bolt.**

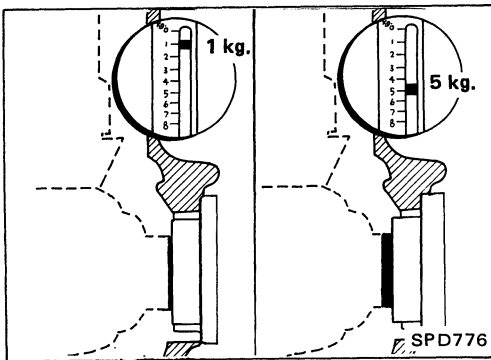

7. If necessary, correct the carrier bearing preload by adding to or subtracting from the *total* amount of shim thickness.

Add shim thickness to increase turning force on the carrier.

Subtract shim thickness to decrease turning force on the carrier.

ADJUSTMENT (Model H190A)

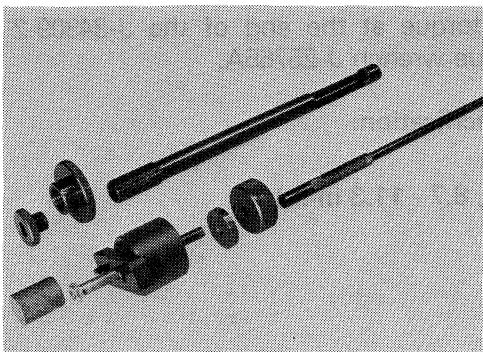

Pinion Gear Height

1. Make sure all parts are clean and that the bearings are well lubricated.
2. Assemble the pinion gear bearings into the pinion pre-load shim selector tool, J-34309.

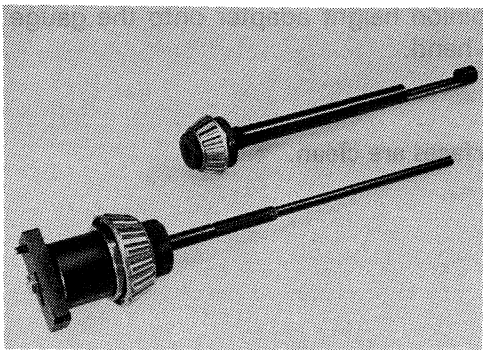

- **Front Pinion Bearing** — make sure the J-34309-3 front pinion bearing is secured tightly against the J-34309 gauge anvil. Then turn the front pinion bearing pilot J-34309-5 to secure the bearing in its proper position.
- **Rear Pinion Bearing** — the rear pinion bearing pilot, J-34309-15, is used to center the rear pinion bearing only. The rear pinion bearing locking seat, J-34309-4 is used to lock the bearing to the assembly.

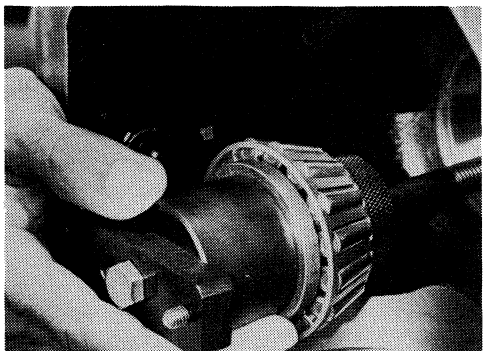

3. Place the pinion pre-load shim selector tool J-34309-1 gauge screw assembly with the pinion rear bearing inner cone installed into the final drive housing.

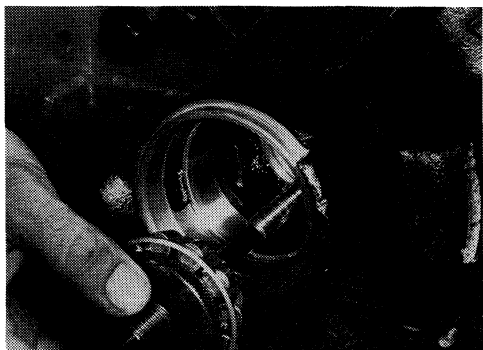

4. Assemble the front pinion bearing inner cone and the J-34309-2 gauge anvil together with the J-34309-1 gauge screw in the final drive housing. Make sure that the pinion height gauge plate, J-34309-16, will turn a full 360 degrees, and tighten the two sections together by hand.

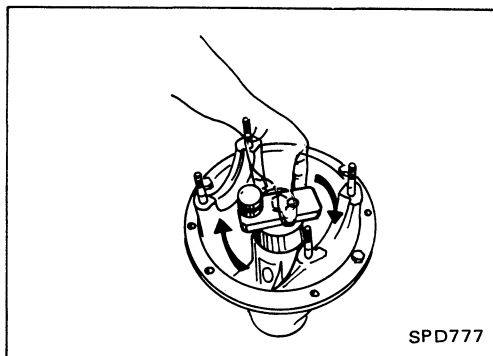

5. Turn the assembly several times to seat the bearings.

ADJUSTMENT (Model H190A)

Pinion Gear Height (Cont'd)

6. Measure the turning torque at the end of the J-34309-2 gauge anvil using torque wrench J-25765A.

Turning torque specification:

1.0 - 1.3 N·m
(10 - 13 kg·cm, 8.7 - 11.3 in·lb)

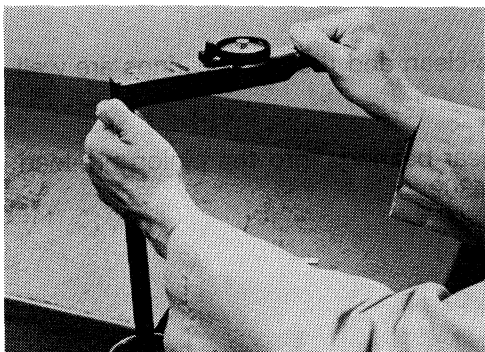

7. Place the J-34309-14 pinion height adapter onto the gauge plate and tighten it by hand.

CAUTION:

Make sure all machined surfaces are clean.

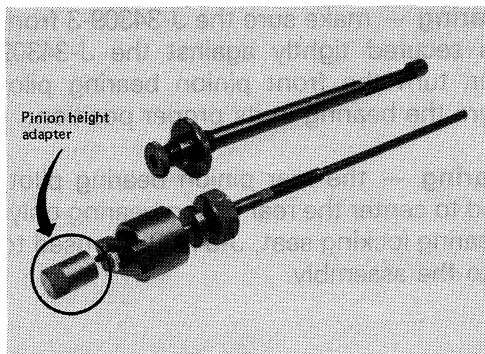

PINION HEIGHT ADJUSTING WASHER SELECTION

8. Now, position the side bearing discs, J-25269-18, and arbor firmly into the side bearing bores.



9. Install the side bearing caps and torque the cap bolts.

Specification:

49 - 59 N·m
(5 - 6 kg·m, 36 - 43 ft·lb)

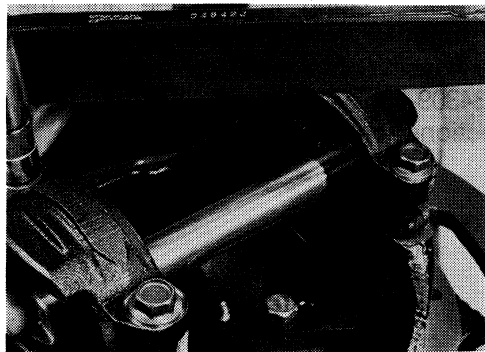

10. Select the correct standard pinion height adjusting washer thickness by using a J-34309-101 feeler gauge. Measure the gap between the J-34309-14 pinion height adapter and the arbor.

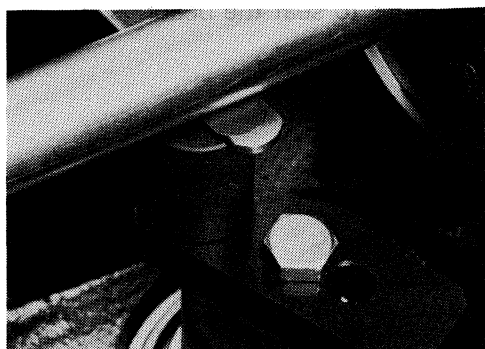

ADJUSTMENT (Model H190A)

Pinion Gear Height (Cont'd)

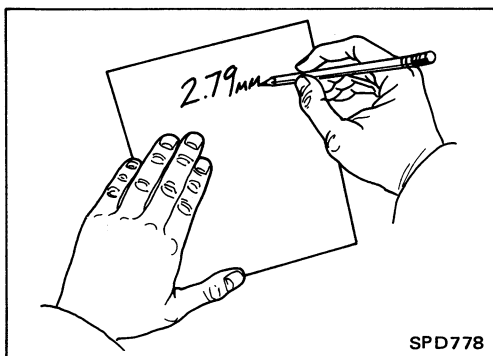

11. Write down your exact total measurement.

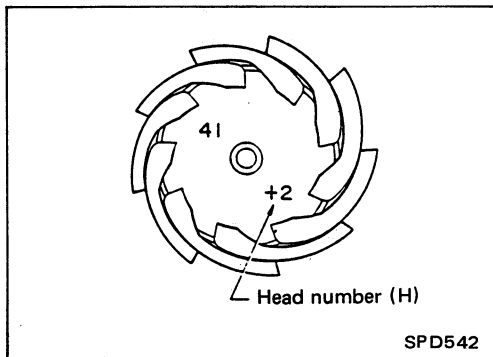

12. Correct the pinion height washer size by referring to the "pinion head number."

NOTE:

There are two numbers painted on the pinion gear. The first one refers to the pinion and ring gear as a matched set and should be the same as the number on the ring gear. The second number is the "pinion head height number," and it refers to the ideal pinion height from standard for the quietest operation.

Use the following chart to determine the correct pinion height washer.

Pinion Head Height Number	Add or Remove From the Standard Pinion Height Washer Thickness Measurement
-6	Add 0.06 mm (0.0024 in)
-5	Add 0.05 mm (0.0020 in)
-4	Add 0.04 mm (0.0016 in)
-3	Add 0.03 mm (0.0012 in)
-2	Add 0.02 mm (0.0008 in)
-1	Add 0.01 mm (0.0004 in)
0	Use the selected washer thickness
+1	Subtract 0.01 mm (0.0004 in)
+2	Subtract 0.02 mm (0.0008 in)
+3	Subtract 0.03 mm (0.0012 in)
+4	Subtract 0.04 mm (0.0016 in)
+5	Subtract 0.05 mm (0.0020 in)
+6	Subtract 0.06 mm (0.0024 in)

ADJUSTMENT (Model H190A)

Pinion Gear Height (Cont'd)

13. Select the correct pinion height washer from the following chart.

Drive Pinion Height Adjusting Washer H190-ML and H190A	
Thickness mm (in)	Part No.
2.58 (0.1016)	38154-P6000
2.61 (0.1028)	38154-P6001
2.64 (0.1039)	38154-P6002
2.67 (0.1051)	38154-P6003
2.70 (0.1063)	38154-P6004
2.73 (0.1075)	38154-P6005
2.76 (0.1087)	38154-P6006
2.79 (0.1098)	38154-P6007
2.82 (0.1110)	38154-P6008
2.85 (0.1122)	38154-P6009
2.88 (0.1134)	38154-P6010
2.91 (0.1146)	38154-P6011
2.94 (0.1157)	38154-P6012
2.97 (0.1169)	38154-P6013
3.00 (0.1181)	38154-P6014
3.03 (0.1193)	38154-P6015
3.06 (0.1205)	38154-P6016
3.09 (0.1217)	38154-P6017
3.12 (0.1228)	38154-P6018
3.15 (0.1240)	38154-P6019
3.18 (0.1252)	38154-P6020

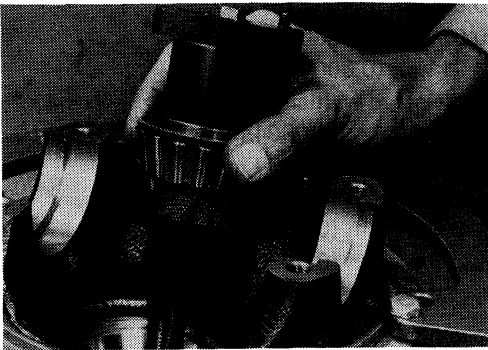

14. Remove the J-34309 pinion preload shim selector tool from the final drive housing and disassemble to retrieve the pinion bearings.

ADJUSTMENT (Model H190A)

Tooth Contact

Checking of gear tooth contact pattern is necessary to verify correct relationship between ring gear and drive pinion.

Hypoid gear sets which are not positioned properly in relation to one another may be noisy, or have short life, or both. With a pattern check, the most desirable contact for low noise level and long life can be assured.

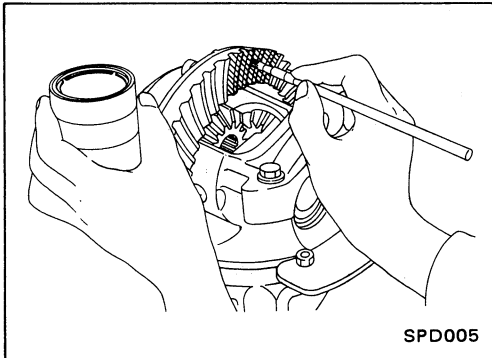

SPD005

1. Thoroughly clean ring gear and drive pinion teeth.
2. Sparingly apply a mixture of powdered ferric oxide and oil or equivalent to 3 or 4 teeth of ring gear drive side.

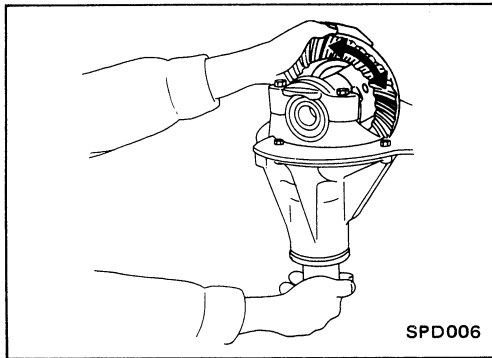

SPD006

3. Hold companion flange steady by hand and rotate the ring gear in both directions.

Usually the pattern will be correct if you have calculated the shims correctly and the backlash is correct. However, in rare cases you may have to use trial-and-error processes until you get a good tooth contact pattern. The tooth pattern is the best indication of how well the final drive has been set up.

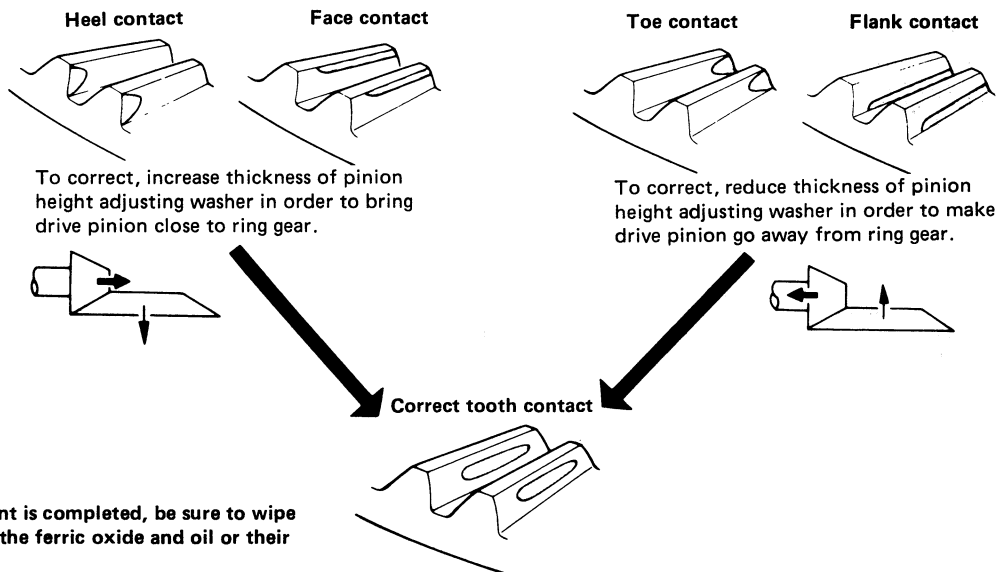

When adjustment is completed, be sure to wipe off completely the ferric oxide and oil or their equivalent.

SPD007

ASSEMBLY (Model H190A)

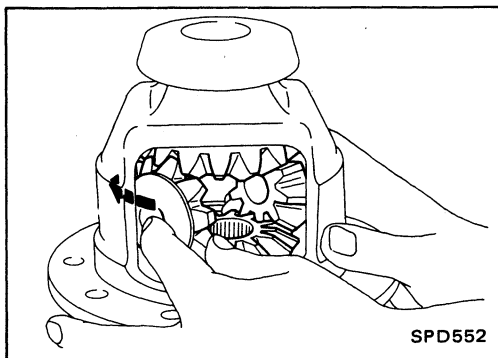

Differential Case

1. Install side gears, pinion mate gears and thrust washers into differential case.

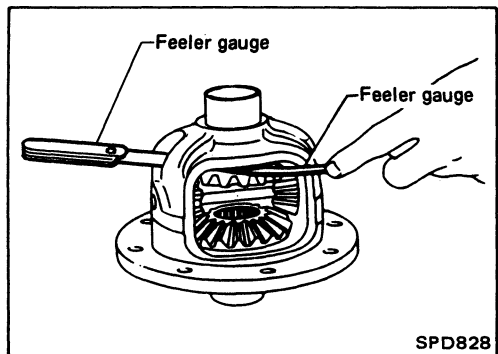

2. Fit pinion mate shaft to differential case so that it meets lock pin holes.
3. Adjust backlash between side gear and pinion mate gear by selecting side gear thrust washer. (Refer to S.D.S.)

**Backlash between side gear and pinion mate gear
(Clearance between side gear thrust washer and differential case):**

0.10 - 0.20 mm (0.0039 - 0.0079 in)

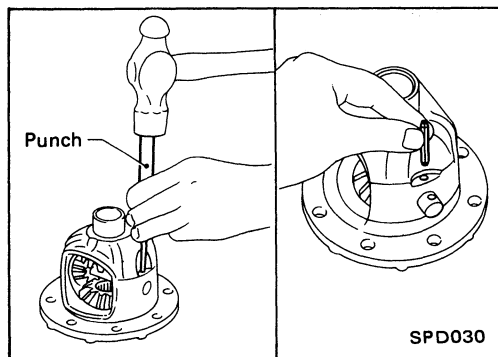

4. Install pinion mate shaft lock pin with a punch.
Make sure lock pin is flush with case.

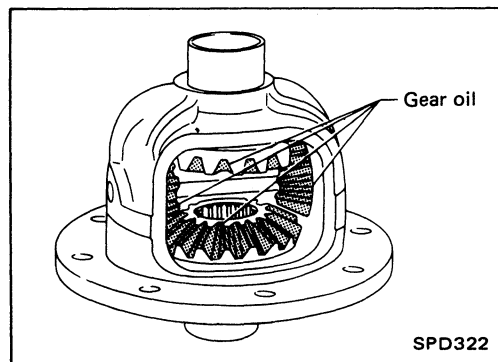

5. Apply gear oil to gear tooth surfaces and thrust surfaces and check to see they turn properly.

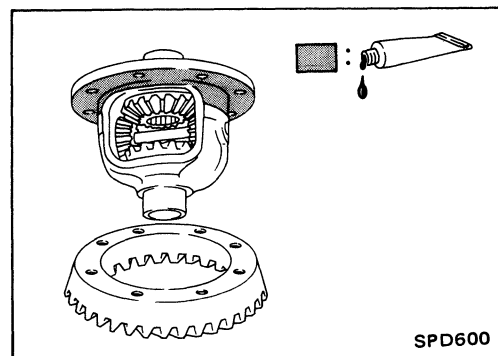

6. Apply locking agent [Loctite (stud lock) or equivalent] to contacting surfaces of ring gear and differential case, then place differential case on ring gear.

ASSEMBLY (Model H190A)

Differential Case (Cont'd)

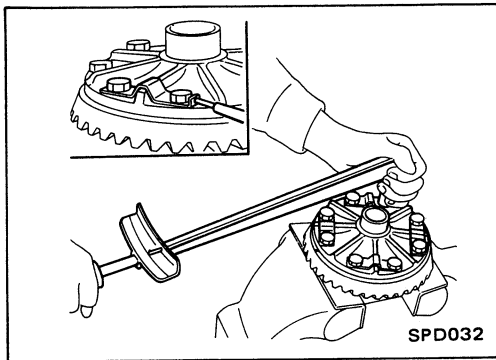

7. Apply a small amount of locking agent (described on previous page) to ring gear bolts.
8. Install new lock straps and ring gear bolts.
 - Tighten bolts in a criss-cross fashion, lightly tapping bolt head with a hammer.
 - Then bend up lock straps to lock the bolts in place.

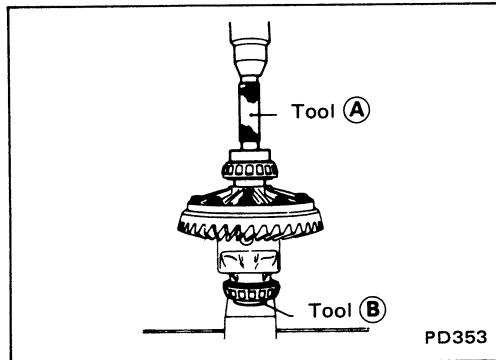

9. Select side bearing adjusting shims.
Refer to ADJUSTMENT.
10. Install the shims behind each bearing and press on side bearing inner cones with Tool.

Tool number:

- (A) ST33230000 (J25805-01)
- (B) ST33061000 (J8107-2)

Differential Carrier

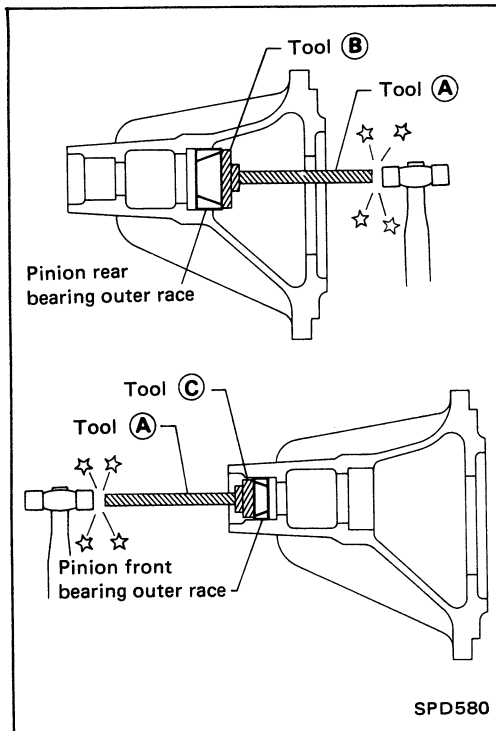

1. Press fit front and rear bearing outer races with Tools.

Tool number:

- (A) ST30611000 (J25742-1)
- (B) ST30621000 (-)
- (C) ST30613000 (J25742-3)

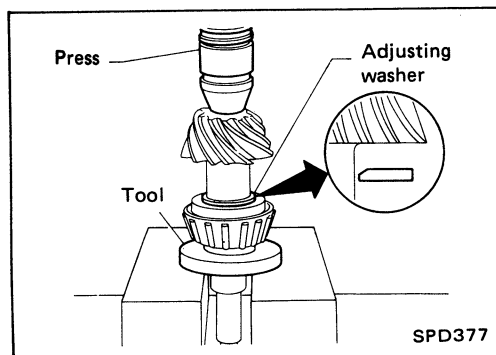

2. Select pinion height adjusting washer, referring to ADJUSTMENT.
3. Install pinion height adjusting washer in drive pinion, and press fit rear bearing inner cone in it with press and Tool.

Tool number: ST30901000 (-)

Equivalent tool (J26010-01)

ASSEMBLY (Model H190A)

Differential Carrier (Cont'd)

- Place pinion front bearing inner cone in gear carrier.

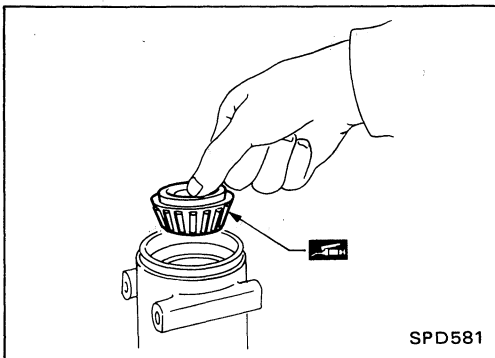

- Apply multi-purpose grease to cavity at sealing lips of oil seal. Install front oil seal.

Tool number:

- Ⓐ ST30720000 (-)
Equivalent tool (J25405)
- Ⓑ KV38102510 (-)

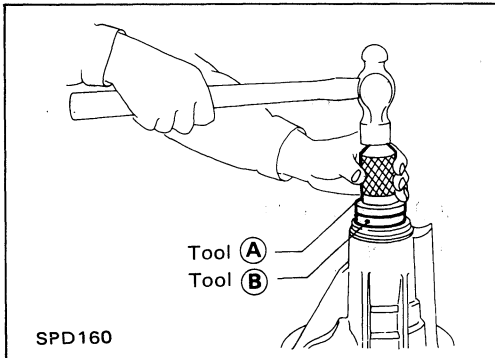

- Install drive pinion washer, collapsible spacer and drive pinion in gear carrier.

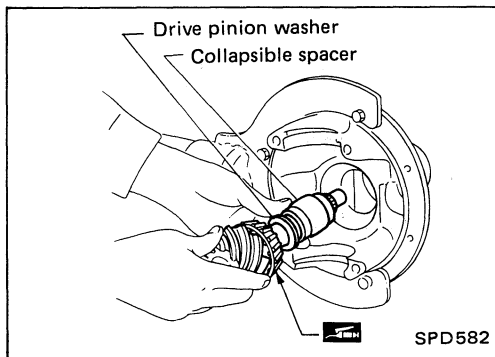

- Install companion flange and hold it firmly. Insert pinion into companion flange by tapping its head with a soft hammer.

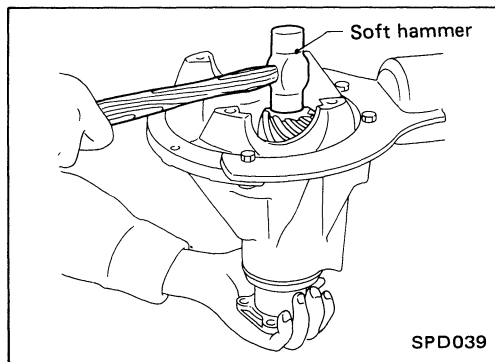

- Temporarily tighten pinion nut until there is no axial play. The threaded portion of drive pinion and pinion nut should be free from oil or grease.

Tool number: ST38060002 (J34311)

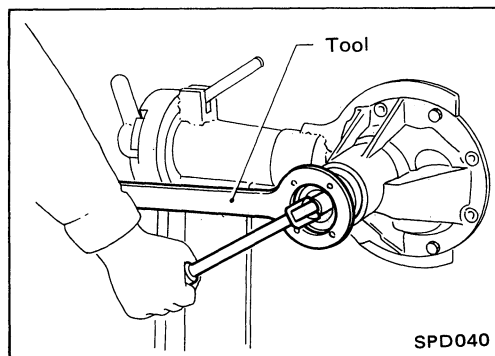

ASSEMBLY (Model H190A)

Differential Carrier (Cont'd)

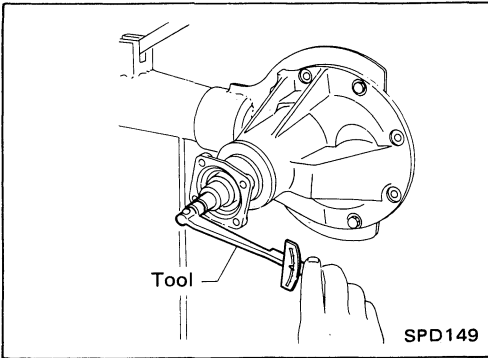

9. Tighten pinion nut by degrees to the specified preload while checking the preload with Tools.

When checking preload, turn drive pinion in both directions several times to seat bearing rollers correctly.

Pinion bearing preload:

1.1 - 1.6 N·m (11 - 16 kg-cm, 9.5 - 13.9 in-lb)

Tool number: ST3127S000 (See J25765-A)

CAUTION:

The preload is achieved by using the permanent set of collapsible spacer. So here, if an overpreload results from excessive turning of the pinion nut, the spacer should be replaced by new one.

10. Select side bearing adjusting shim.

Refer to ADJUSTMENT.

11. Install differential case assembly with side bearing outer races into gear carrier.

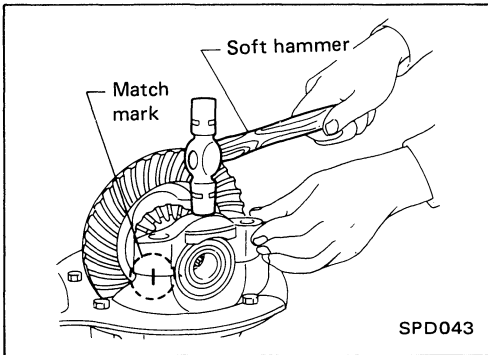
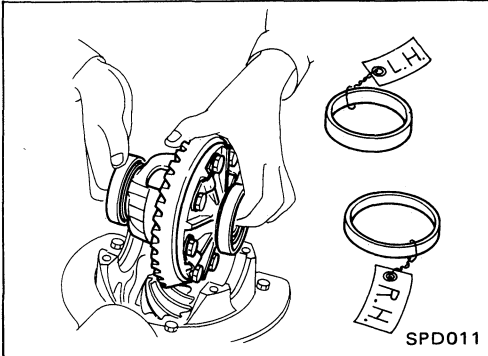

12. Align mark on bearing cap with that on gear carrier and install bearing cap on gear carrier.

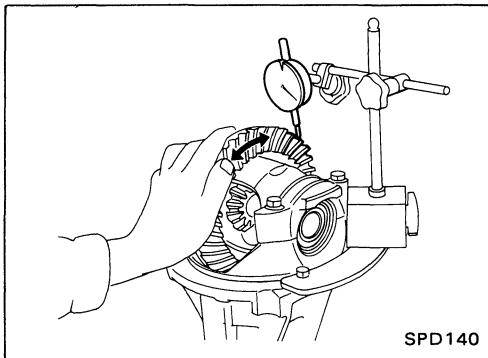

13. Measure ring gear-to-drive pinion backlash with a dial indicator.

Ring gear-to-drive pinion backlash:

0.13 - 0.18 mm (0.0051 - 0.0071 in)

- If backlash is too small, decrease thickness of left shim and increase thickness of right shim by the same amount.
- If backlash is too great, reverse the above procedure.

Never change the total amount of shims as it will change the bearing preload.

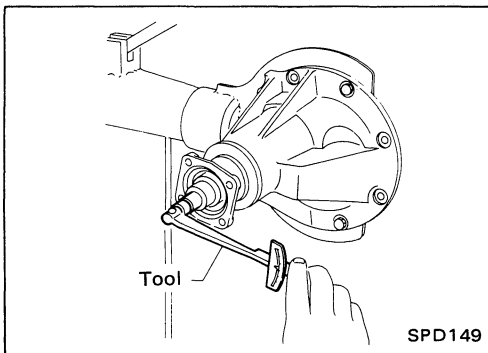

14. Check total preload with Tool.

When checking preload, turn drive pinion in both directions several times to set bearing rollers.

Tool number: ST3127S000 (See J25765-A)

Total preload:

1.2 - 2.2 N·m (12 - 22 kg-cm, 10 - 19 in-lb)

Differential Carrier (Cont'd)

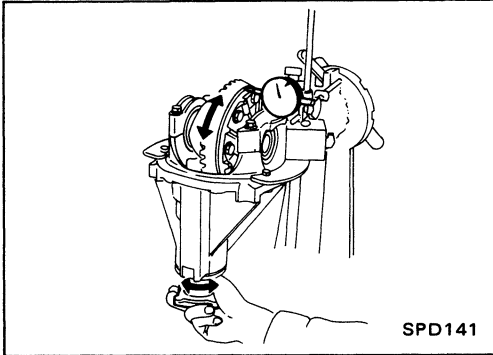
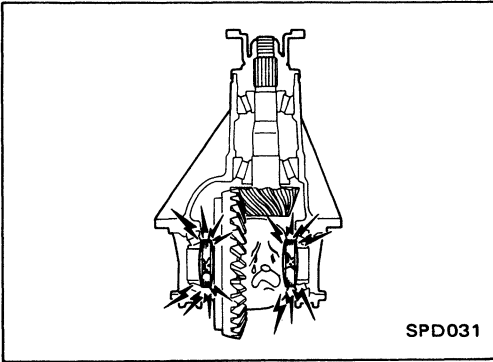

- If preload is too great, remove the same amount of shims from each side.
- If preload is too small, add the same amount of shims to each side.

Never add or remove a different number of shims for each side as it will change ring gear-to-drive pinion backlash.

15. Recheck ring gear-to-drive pinion backlash because an increase or decrease in thickness of shims will cause change of ring gear-to-drive pinion backlash.

16. Check runout of ring gear with a dial indicator.

Runout limit: 0.08 mm (0.0031 in)

- If backlash varies excessively in different places, the variance may have resulted from foreign matter caught between the ring gear and the differential case.
- If the backlash varies greatly when the runout of the ring gear is within a specified range, the hypoid gear set or differential case should be replaced.

17. Check tooth contact.
Refer to Adjustment.

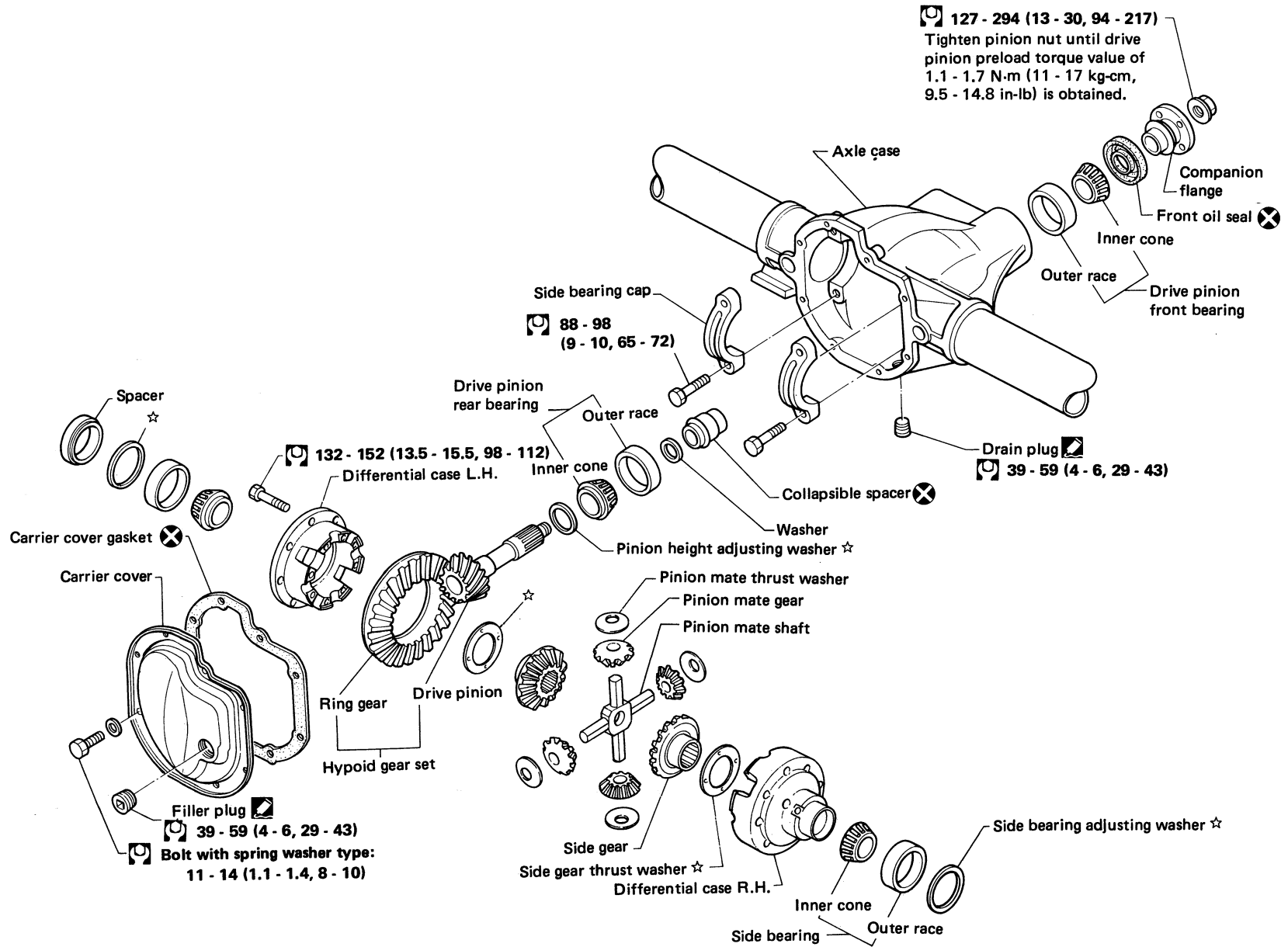

- : N·m (kg·m, ft·lb)
- : Always replace when disassembled.
- : Adjustment is required.

DISASSEMBLY (Model C200)

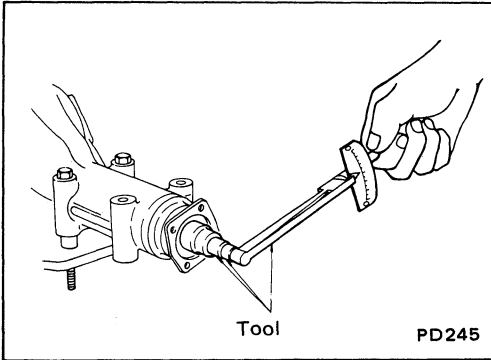

Pre-inspection

Before disassembling final drive, perform the following inspection.

- Total preload
 - 1) Turn drive pinion in both directions several times to set bearing rollers.
 - 2) Check total preload with Tool.

Tool number: ST3127S000 (See J25765-A)

Total preload:

1.2 - 2.3 N·m

(12 - 23 kg-cm, 10 - 20 in-lb)

- Ring gear to drive pinion backlash.
Check backlash of ring gear with a dial indicator at several points.

Ring gear-to-drive pinion backlash:

0.13 - 0.18 mm (0.0051 - 0.0071 in)

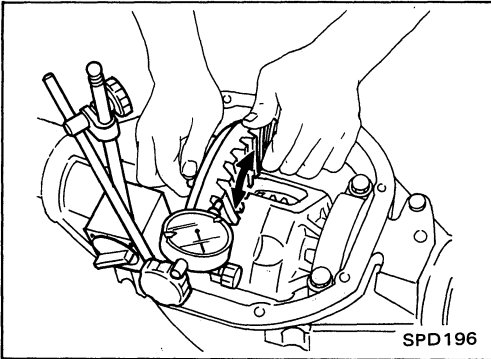

- Ring gear runout
Check runout of ring gear with a dial indicator.

Runout limit: 0.08 mm (0.0031 in)

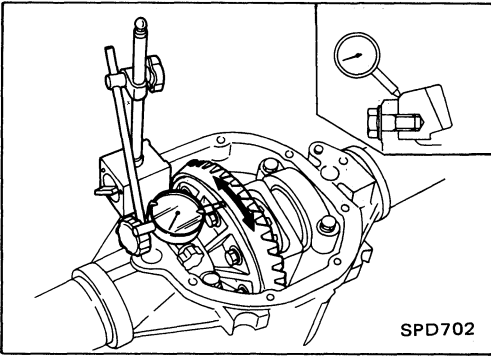

- Tooth contact
Check tooth contact. (Refer to ADJUSTMENT.)
- Side gear to pinion mate gear backlash
Measure clearance between side gear thrust washer and differential case with a feeler gauge.

Clearance between side gear thrust washer and differential case:

0.10 - 0.20 mm (0.0039 - 0.0079 in)

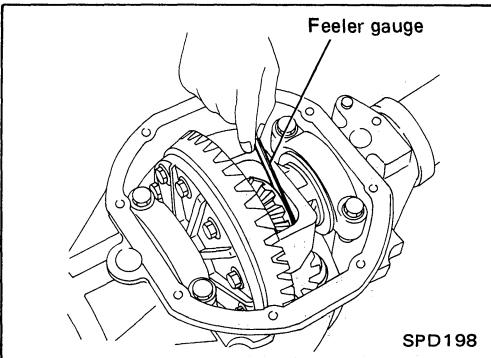

Differential Carrier

1. Remove rear cover and rear cover gasket.
2. Put match marks on one side of side bearing cap with paint or punch to ensure that it is replaced in proper position during reassembly.

Bearing caps are line-bored during manufacture and should be put back in their original places.

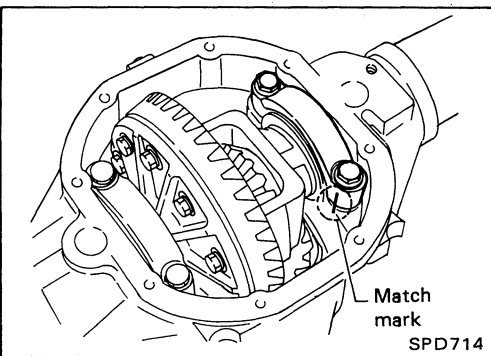

DISASSEMBLY (Model C200)

Differential Carrier (Cont'd)

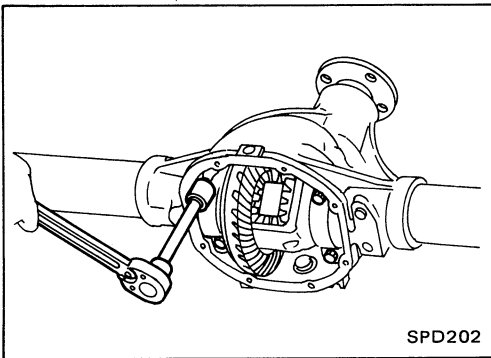

3. Remove side bearing caps.

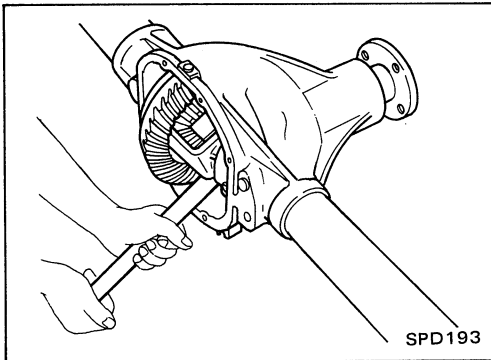

4. Remove differential case assembly with pry bar.

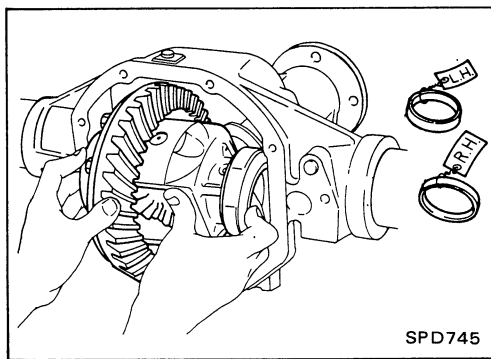

Keep the side bearing outer races together with their respective inner cones – do not mix them up.

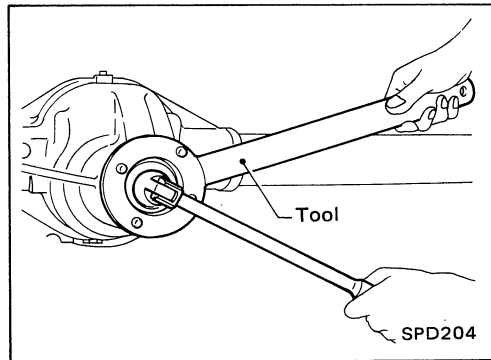

5. Remove pinion nut with Tool.

Tool number:

Except Van and Wagon models

ST38060002 (J34311)

Van and Wagon models

KV38104700 (J34311)

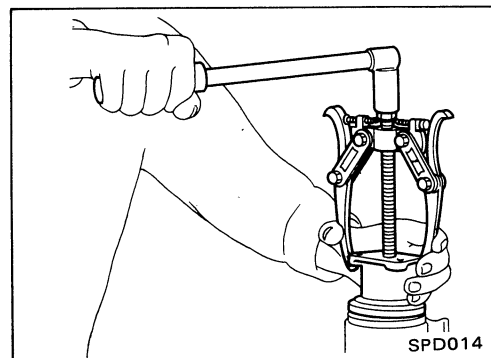

6. Remove companion flange with puller.

DISASSEMBLY (Model C200)

Differential Carrier (Cont'd)

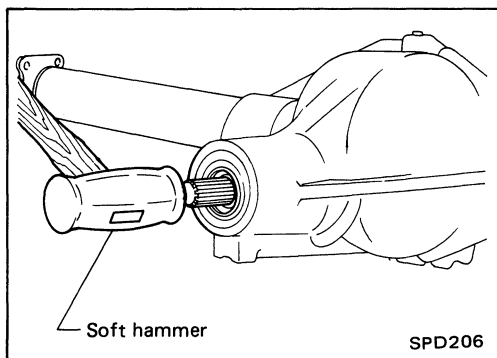

7. Remove drive pinion with soft hammer.
8. Remove front oil seal and pinion front bearing inner cone.

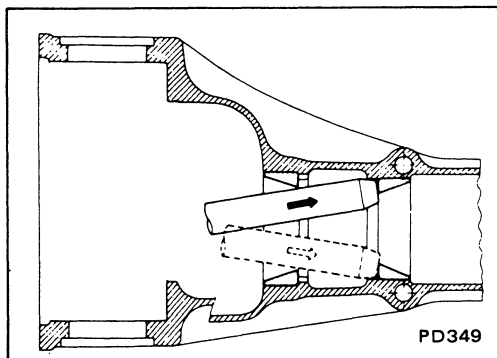

9. Remove side oil seal.
10. Remove pinion bearing outer races with a brass drift.

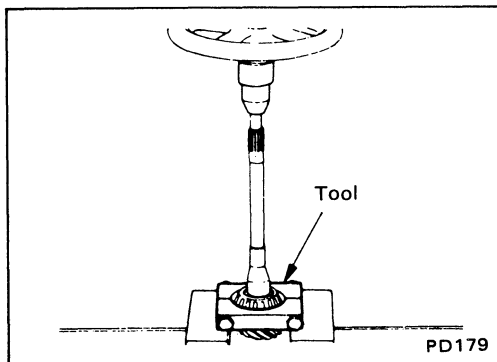

11. Remove pinion rear bearing inner cone and pinion height adjusting washer.

Tool number: ST30031000 (J22912-01)

Differential Case

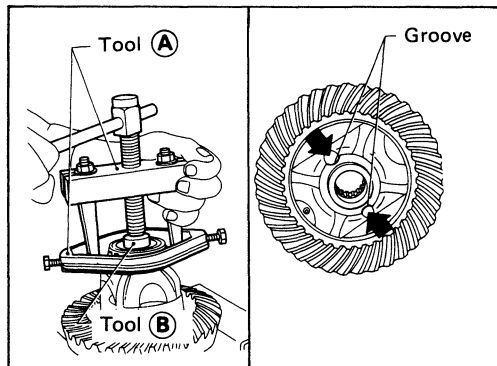

1. Remove side bearing inner cones.
- To prevent damage to bearing, engage puller jaws in grooves.

Tool number:

- (A) ST33051001 (-)
Equivalent tool (J22888)
- (B) ST33061000 (J8107-2)

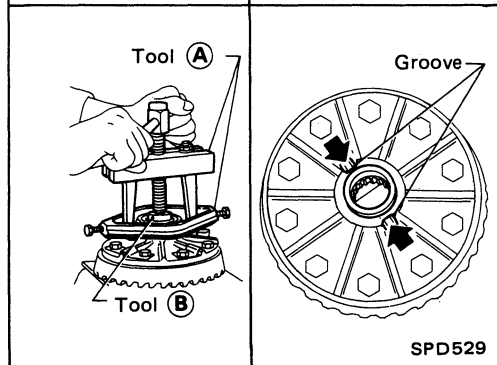

DISASSEMBLY (Model C200)

Differential Case (Cont'd)

Be careful not to confuse the right and left hand parts.

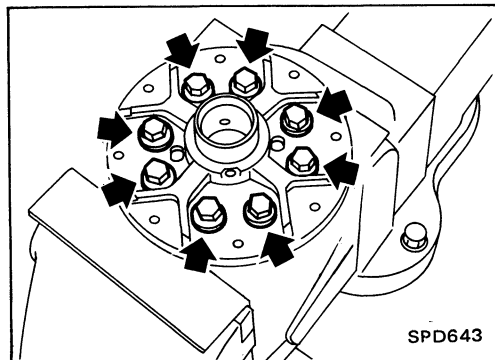
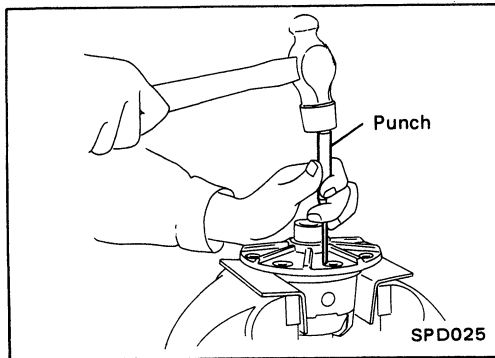
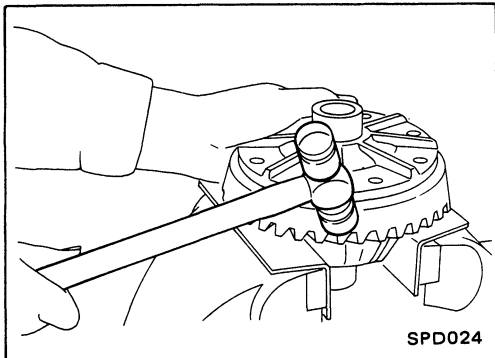
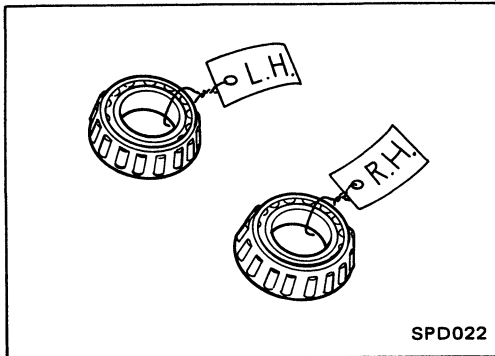

2. Loosen ring gear bolts in a criss-cross fashion.
3. Tap ring gear off the differential case with a soft hammer. Tap evenly all around to keep ring gear from binding.
4. Punch off pinion mate shaft lock pin from ring gear side (2-pinion type differential case). Lock pin is calked at pin hole mouth on differential case.
5. Separate differential case L.H. and R.H. (4-pinion type differential case). Put match marks on both differential case L.H. and R.H. sides prior to separating them.

Ring Gear and Drive Pinion

Check gear teeth for scoring, cracking or chipping. If any damaged part is evident, replace ring gear and drive pinion as a set (hypoid gear set).

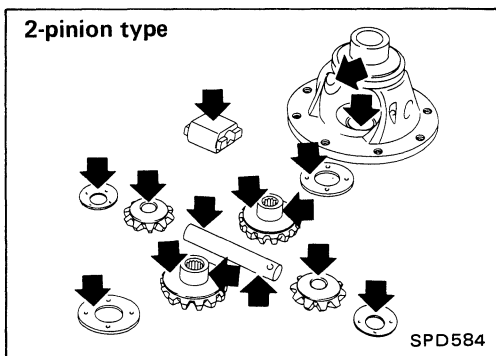

Differential Case Assembly

Check mating surfaces of differential case, side gears, pinion mate gears, pinion mate shaft, thrust block and thrust washers.

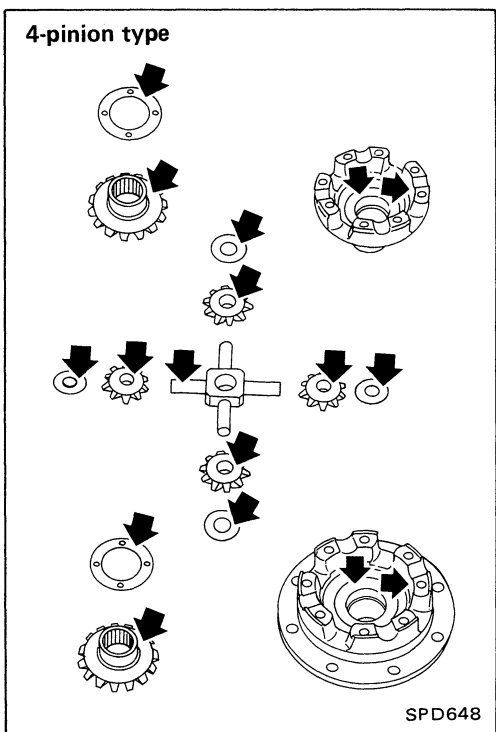

Bearing

1. Thoroughly clean bearing.
2. Check bearings for wear, scratches, pitting or flaking.
Check tapered roller bearing for smooth rotation. If damaged, replace outer race and inner cone as a set.

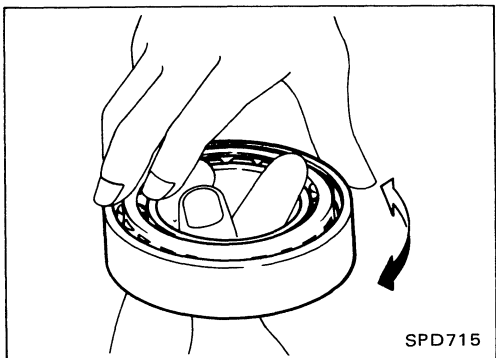

ADJUSTMENT (Model C200)

For quiet and reliable final drive operation, the following five adjustments must be made correctly:

1. Side Bearing Preload.
2. Pinion Gear Height.
3. Pinion Bearing Preload. (Refer to ASSEMBLY.)
4. Ring Gear-to-pinion Backlash. (Refer to ASSEMBLY.)
5. Ring and Pinion Gear Tooth Contact Pattern.

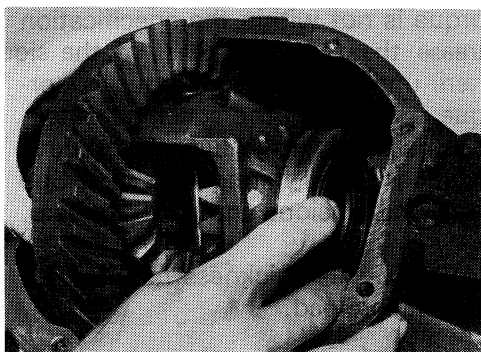

Side Bearing Preload

A selection of carrier side bearing preload shims is required for successful completion of this procedure.

1. Make sure all parts are clean and that the bearings are well lubricated with light oil or Dexron type automatic transmission fluid.
2. Place the differential carrier, with side bearings and bearing races installed, into the final drive housing.
3. Put the side bearing spacer in place on the ring gear end of the carrier.
4. Using the J-25267 side bearing shim installer, place both of the original carrier side bearing preload shims on the carrier end, opposite the ring gear.

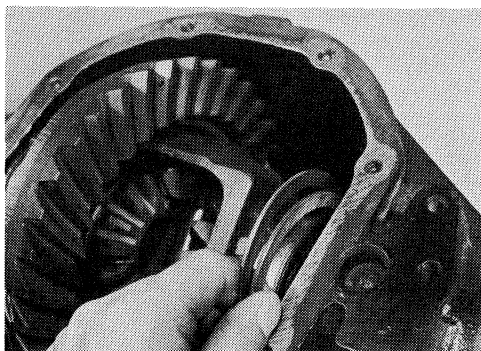
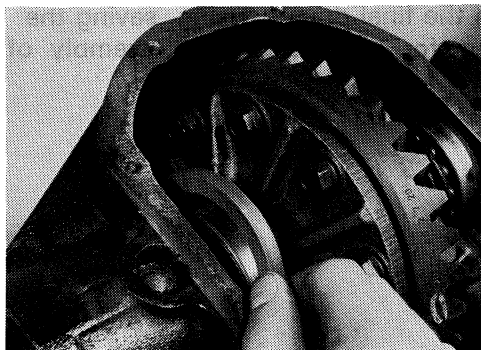

ADJUSTMENT (Model C200)

Side Bearing Preload (Cont'd)

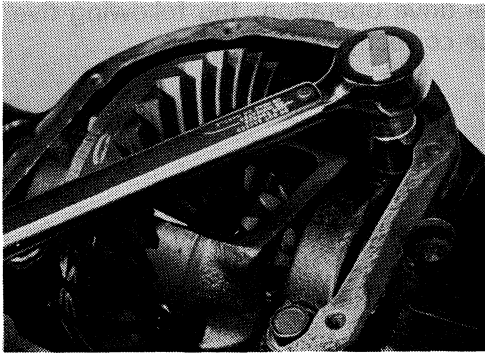

5. Install the side bearing caps in their correct locations and torque the bearing cap retaining bolts.

Specification:

88 - 98 N·m (9 - 10 kg·m, 65 - 72 ft·lb)

6. Turn the carrier several times to seat the bearings.

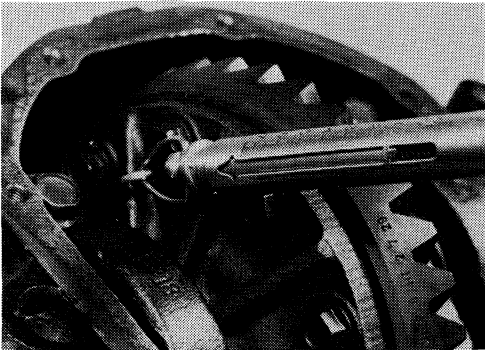

7. Measure the turning torque of the carrier at the ring gear retaining bolts with a spring gauge, J-8129.

Specification:

**34.3 - 39.2 N (3.5 - 4.0 kg, 7.7 - 8.8 lb)
of pulling force at the ring gear bolt**

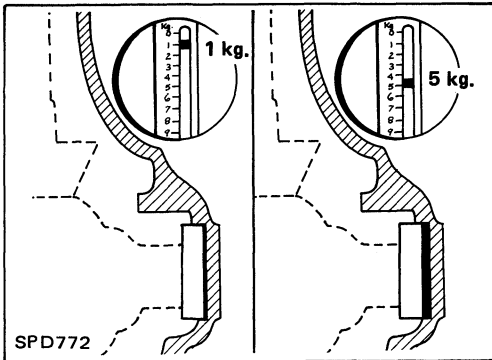

8. If the carrier turning torque is not within the specification range, increase or decrease the total thickness of the side bearing adjusting washers until the turning torque is correct. If the turning torque is less than the specified range, install washers of greater thickness; if the turning torque is greater than the specification, install thinner washers. See the SDS section for washer dimensions and part numbers.

9. Record the total amount of washer thickness required for the correct carrier side bearing preload.

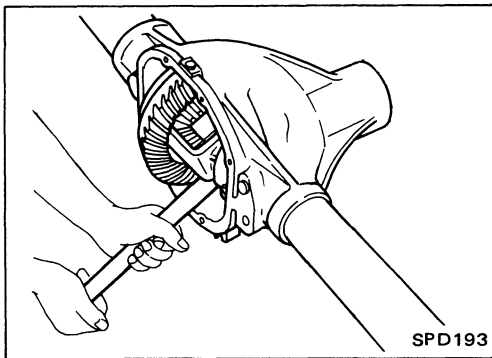

10. Remove the carrier from the final drive housing, saving the selected preload washers for later use during assembly of the final drive unit.

ADJUSTMENT (Model C200)

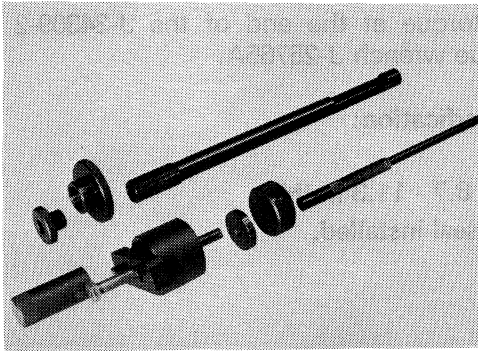

Pinion Gear Height

1. Make sure all parts are clean and that the bearings are well lubricated.
2. Assemble the pinion gear bearings into the pinion pre-load shim selector tool, J-34309.

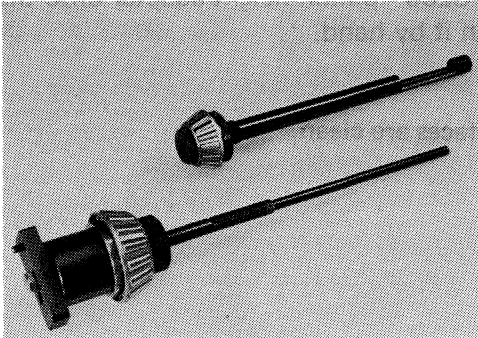

- Front Pinion Bearing — make sure the J-34309-3 front pinion bearing is secured tightly against the J-34309-2 gauge anvil. Then turn the front pinion bearing pilot, J-34309-5, to secure the bearing in its proper position.
- Rear Pinion Bearing — the rear pinion bearing pilot, J-34309-15, is used to center the rear pinion bearing only. The rear pinion bearing locking seat, J-34309-4 is used to lock the bearing to the assembly.

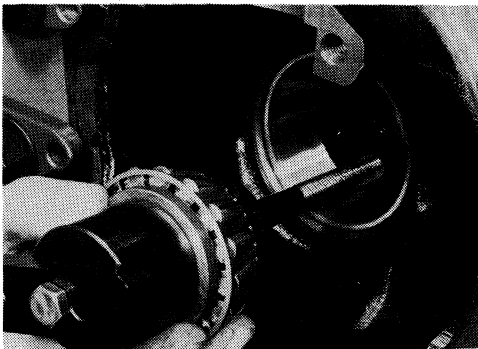

3. Place the pinion preload shim selector tool J-34309-1 gauge screw assembly with the pinion rear bearing inner cone installed into the final drive housing.



4. Assemble the front pinion bearing inner cone and the J-34309-2 gauge anvil together with the J-34309-1 gauge screw in the final drive housing. Make sure that the pinion height gauge plate, J-34309-16, will turn a full 360 degrees, and tighten the two sections together by hand.

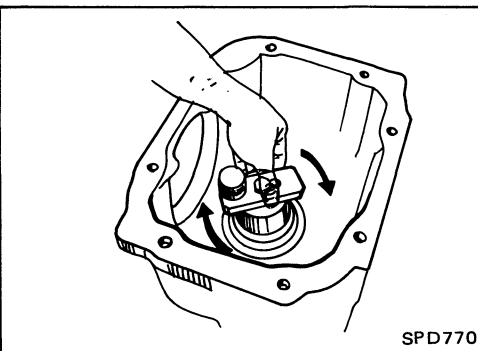

5. Turn the assembly several times to seat the bearings.

ADJUSTMENT (Model C200)

Pinion Gear Height (Cont'd)

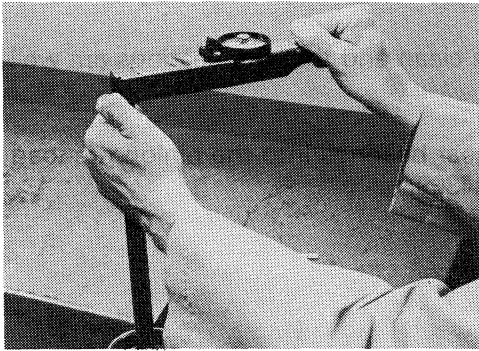

6. Measure the turning torque at the end of the J-34309-2 gauge anvil using torque wrench J-25765A.

Turning torque specification:

1.0 - 1.3 N·m
(10 - 13 kg-cm, 8.7 - 11.3 in-lb)
with no pinion seal installed.

7. Place the J-34309-11 "C200" pinion height adapter onto the gauge plate and tighten it by hand.

CAUTION:

Make sure all machined surfaces are clean.

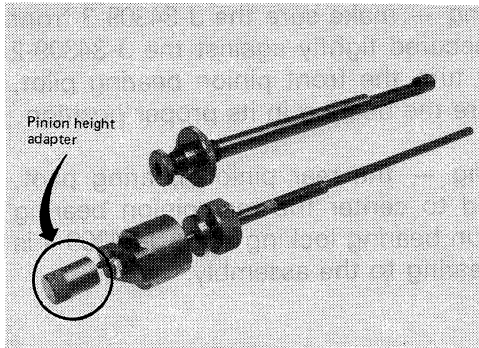

PINION HEIGHT ADJUSTING WASHER SELECTION

8. Now, position the side bearing discs, J-25269-4, and arbor firmly into the side bearing bores.

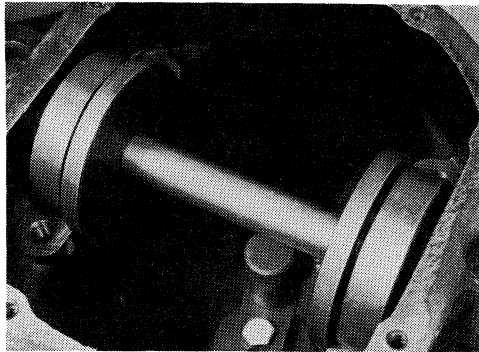

9. Install the side bearing caps and torque the cap bolts.

Specification:

88 - 98 N·m (9 - 10 kg-m, 65 - 72 ft-lb)

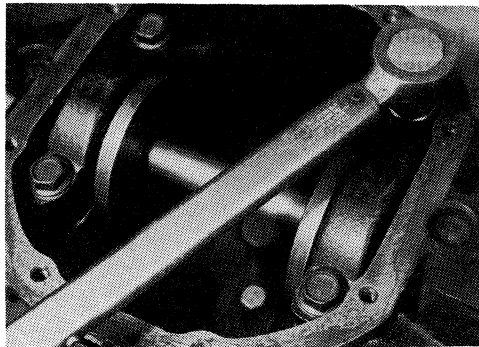

10. Select the correct standard pinion height adjusting washer thickness by using a standard gauge of 3.5 mm (0.138 in) and your J-34309-01 feeler gauge. Measure the gap between the J-34309-11 "C200" pinion height adapter and the arbor.

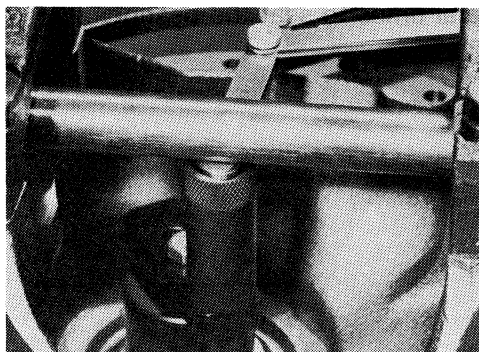

ADJUSTMENT (Model C200)

Pinion Gear Height (Cont'd)

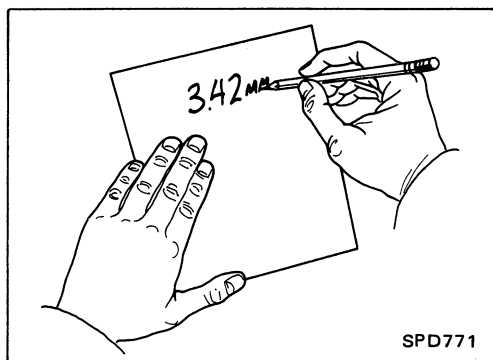

11. Write down your exact total measurement.

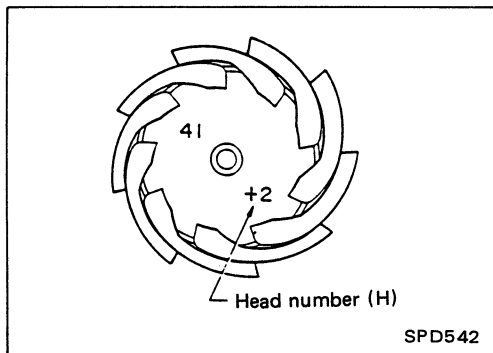

12. Correct the pinion height washer size by referring to the "pinion head number."

NOTE:

There are two numbers painted on the pinion gear. The first one refers to the pinion and ring gear as a matched set and should be the same as the number on the ring gear. The second number is the "pinion head height number," and it refers to the ideal pinion height from standard for the quietest operation.

Use the following chart to determine the correct pinion height washer.

Pinion Height Head Number	Add or Remove From the Standard Pinion Height Washer Thickness Measurement
-6	Add 0.06 mm (0.0024 in)
-5	Add 0.05 mm (0.0020 in)
-4	Add 0.04 mm (0.0016 in)
-3	Add 0.03 mm (0.0012 in)
-2	Add 0.02 mm (0.0008 in)
-1	Add 0.01 mm (0.0004 in)
0	Use the selected washer thickness
+1	Subtract 0.01 mm (0.0004 in)
+2	Subtract 0.02 mm (0.0008 in)
+3	Subtract 0.03 mm (0.0012 in)
+4	Subtract 0.04 mm (0.0016 in)
+5	Subtract 0.05 mm (0.0020 in)
+6	Subtract 0.06 mm (0.0024 in)

ADJUSTMENT (Model C200)

Pinion Gear Height (Cont'd)

13. Select the correct pinion height washer from the following chart.

Drive Pinion Height Adjusting Washer C200	
Thickness mm (in)	Part No.
3.09 (0.1217)	38154-P6017
3.12 (0.1228)	38154-P6018
3.15 (0.1240)	38154-P6019
3.18 (0.1252)	38154-P6020
3.21 (0.1264)	38154-P6021
3.24 (0.1276)	38154-P6022
3.27 (0.1287)	38154-P6023
3.30 (0.1299)	38154-P6024
3.33 (0.1311)	38154-P6025
3.36 (0.1323)	38154-P6026
3.39 (0.1335)	38154-P6027
3.42 (0.1346)	38154-P6028
3.45 (0.1358)	38154-P6029
3.48 (0.1370)	38154-P6030
3.51 (0.1382)	38154-P6031
3.54 (0.1394)	38154-P6032
3.57 (0.1406)	38154-P6033
3.60 (0.1417)	38154-P6034
3.63 (0.1429)	38154-P6035
3.66 (0.1441)	38154-P6036

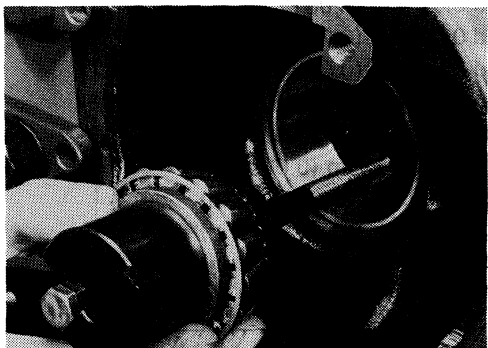

14. Remove the J-34309 pinion preload shim selector tool from the final drive housing and disassemble to retrieve the pinion bearings.

Tooth Contact

Checking gear tooth contact pattern is necessary to verify correct relationship between ring gear and drive pinion.

Hypoid gear sets which are not positioned properly in relation to one another may be noisy, or have short life, or both. With a pattern check, the most desirable contact for low noise level and long life can be assured.

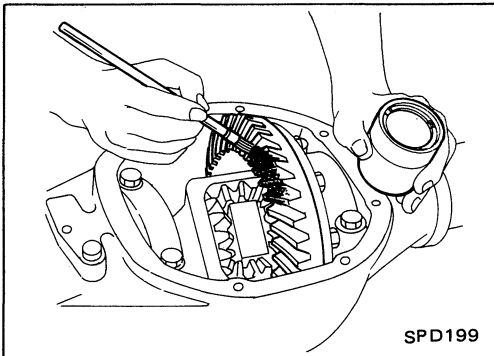

1. Thoroughly clean ring gear and drive pinion teeth.
2. Sparingly apply a mixture of powdered ferric oxide and oil or equivalent to 3 or 4 teeth of ring gear drive side.

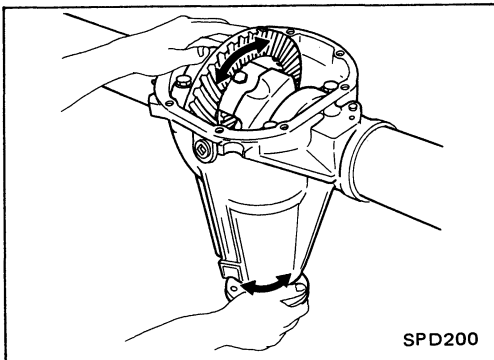

3. Hold companion flange steady by hand and rotate the ring gear in both directions.

Usually the pattern will be correct if you have calculated the shims correctly and the backlash is correct. However, in rare cases you may have to use trial-and-error processes until you get a good tooth contact pattern. The tooth pattern is the best indication of how well the final drive has been set up.

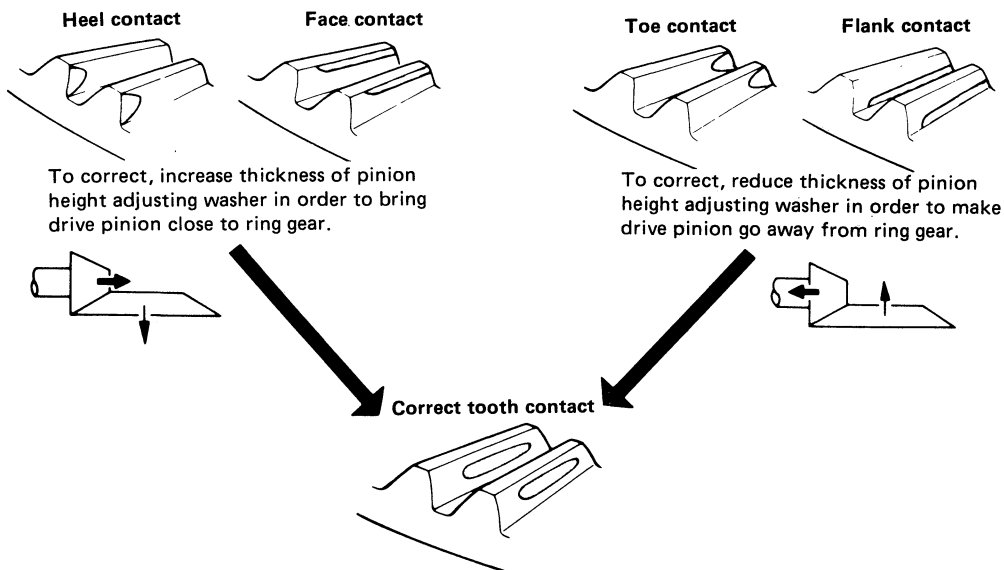

SPD007

ASSEMBLY (Model C200)

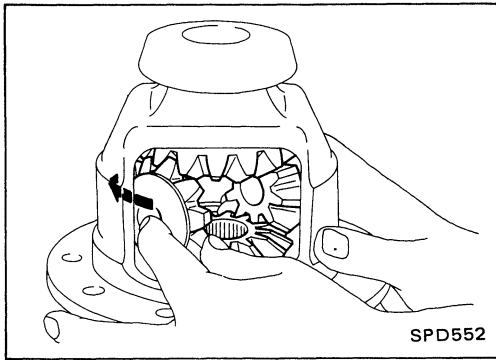

Differential Case — 2-pinion type—

1. Install side gears, pinion mate gears, thrust washers and thrust block into differential case.

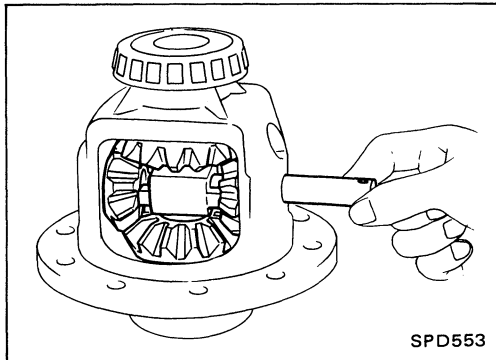

2. Fit pinion mate shaft to differential case so that it meets lock pin holes.

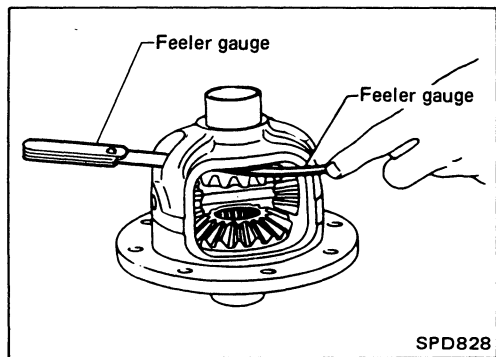

3. Adjust backlash between side gear and pinion mate gear by selecting side gear thrust washer. (Refer to S.D.S.)

**Backlash between side gear and pinion mate gear
(Clearance between side gear thrust washer and
differential case):**

0.10 - 0.20 mm (0.0039 - 0.0079 in)

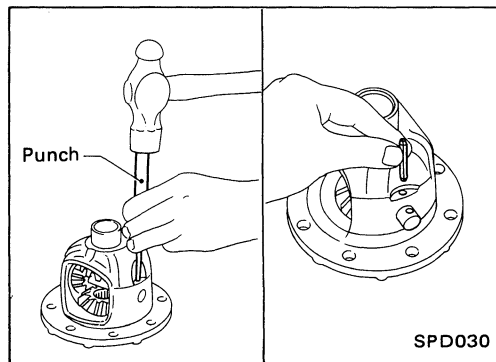

4. Install pinion mate shaft lock pin with a punch.
Make sure lock pin is flush with case.

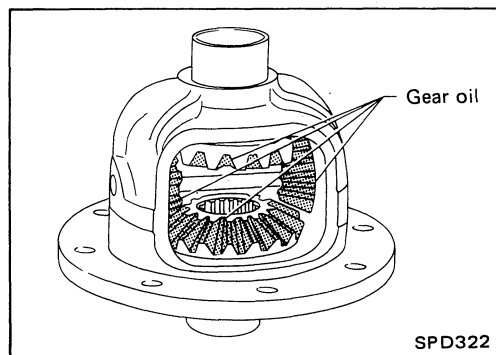

5. Apply gear oil to gear tooth surfaces and thrust surfaces and check to see they turn properly.

ASSEMBLY (Model C200)

Differential Case —2-pinion type— (Cont'd)

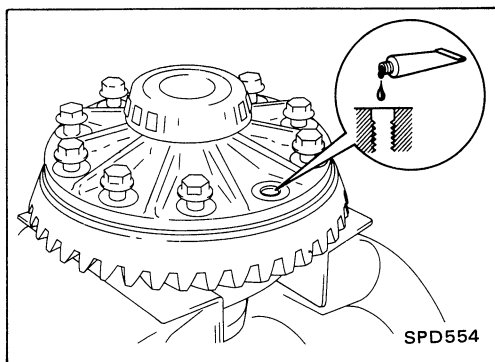

6. Place differential case on ring gear.
7. Apply locking agent [Loctite (stud lock) or equivalent] to ring gear bolts, and install them.

Tighten bolts in a criss-cross fashion, lightly tapping bolt head with a hammer.

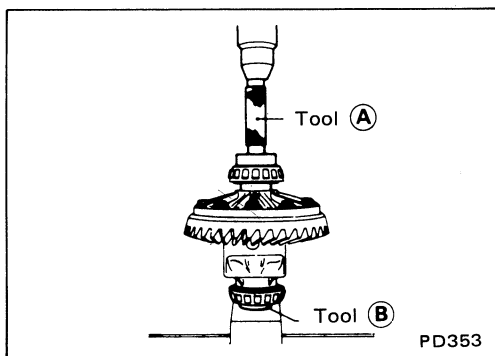

8. Press-fit side bearing inner cones on differential case with Tool.

Tool number:

- Ⓐ ST33230000 (J25805-01)
- Ⓑ ST33061000 (J8107-2)

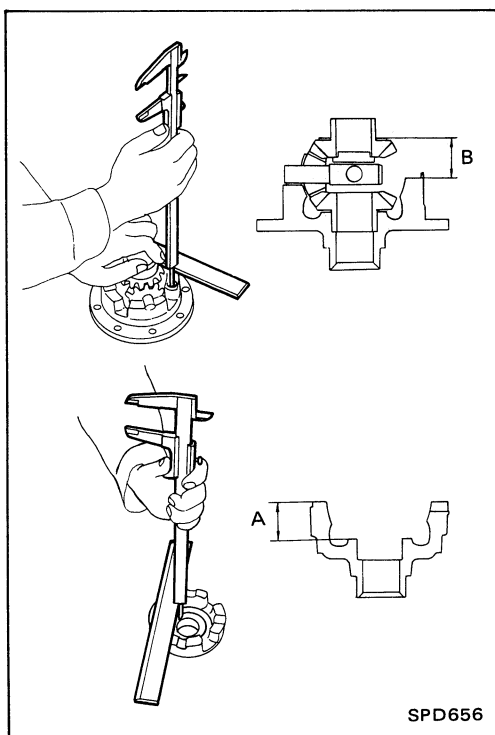

Differential Case —4-pinion type—

1. Measure clearance between side gear thrust washer and differential case.

Clearance between side gear thrust washer and differential case (A - B):

0.10 - 0.20 mm (0.0039 - 0.0079 in)

The clearance can be adjusted with side gear thrust washer. (Refer to S.D.S.)

2. Apply gear oil to gear tooth surfaces and thrust surfaces and check to see they turn properly.

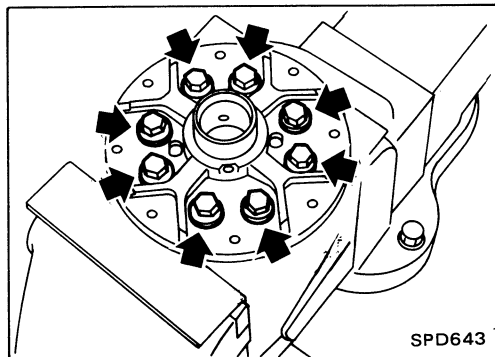

3. Install differential case L.H. and R.H.
4. Install differential case on ring gear.

ASSEMBLY (Model C200)

Differential Case —4-pinion type— (Cont'd)

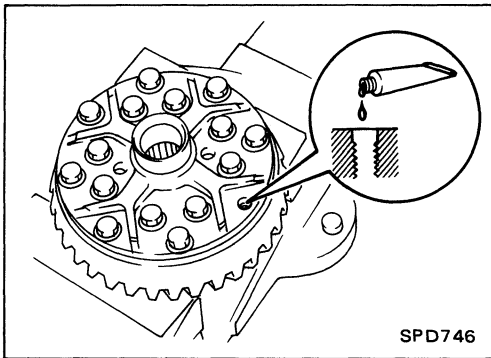

5. Place differential case on ring gear.
6. Apply locking agent [Locktite (stud lock) or equivalent] to ring gear bolts, and install them.

Tighten bolts in a criss-cross fashion, lightly tapping bolt head with a hammer.

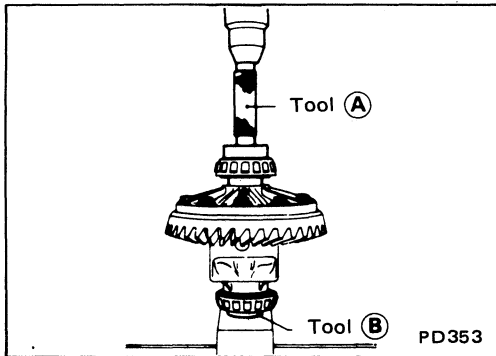

7. Press-fit side bearing inner cones on differential case with Tool.

Tool number:

- (A) ST33230000 (J25805-01)
- (B) ST33061000 (J8107-2)

Differential Carrier

1. Press-fit front and rear bearing outer races with Tools.

Tool number:

- (A) ST30611000 (J25742-1)
- (B) ST30621000 (J25742-5)
- (C) ST30613000 (J25742-3)

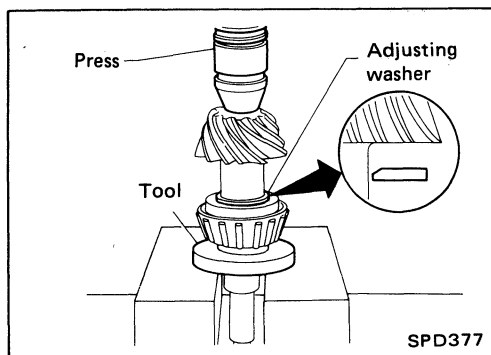
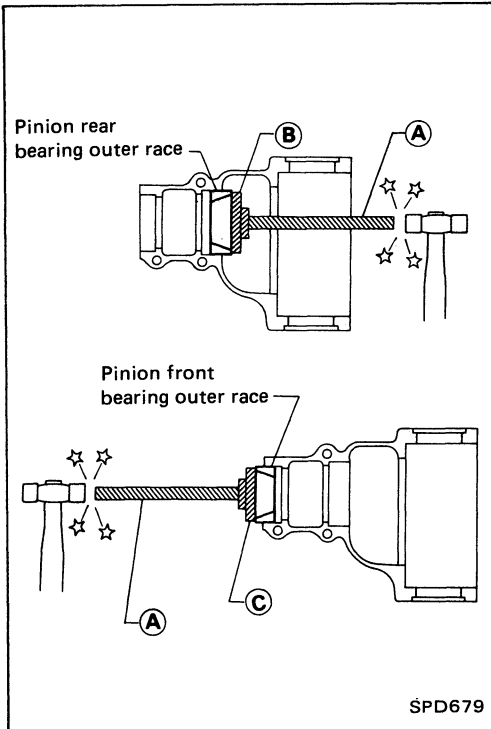

2. Select pinion height adjusting washer, referring to Adjustment.
3. Install pinion height adjusting washer in drive pinion, and press-fit rear bearing inner cone in it, with press and Tool.

Tool number: ST30901000 (-)

Equivalent tool (J26010-01)

ASSEMBLY (Model C200)

Differential Carrier (Cont'd)

4. Place pinion front bearing inner cone in gear carrier.

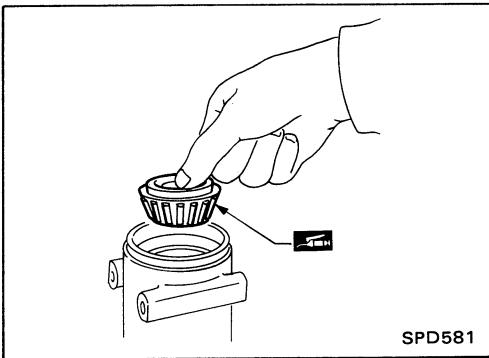

5. Apply multi-purpose grease to cavity at sealing lips of oil seal.
Install front oil seal.

Tool number: KV38100500 (—)

Equivalent tool (J25273)

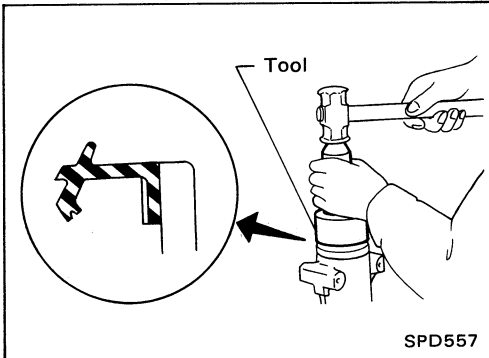

6. Place drive pinion bearing spacer, drive pinion bearing adjusting washer and drive pinion in gear carrier.

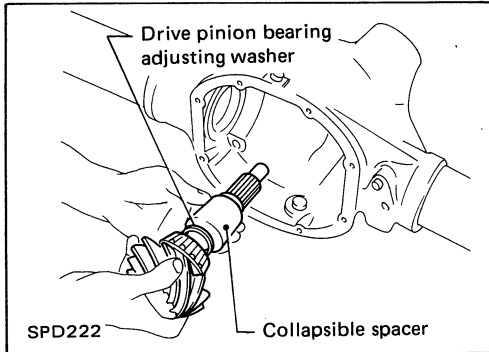

7. Insert companion flange into drive pinion by tapping the companion flange with a soft hammer.

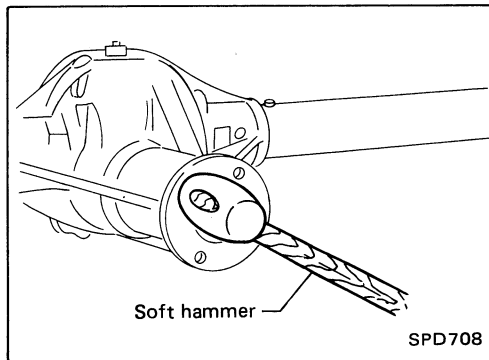

8. Tighten pinion nut to 127 N·m (13 kg·m, 94 ft·lb).
The threaded portion of drive pinion and pinion nut should be free from oil or grease.

Tool number: KV38104700 (J34311)

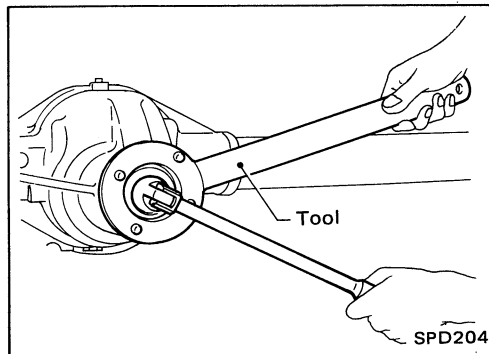

ASSEMBLY (Model C200)

Differential Carrier (Cont'd)

9. Tighten the pinion nut by very small degrees until the specified preload is achieved. When checking the preload, turn the drive pinion in both directions several times to set the bearing rollers.

Tool number: ST3127S000 (See J25765-A)

Pinion bearing preload:

1.1 - 1.7 N·m

(11 - 17 kg·cm, 9.5 - 14.8 in·lb)

This procedure will have to be repeated if:

- Maximum preload is achieved before the minimum pinion nut torque is reached.
- Minimum preload is not achieved before maximum pinion nut torque is reached.

10. Select side bearing adjusting washer.
Refer to Adjustment.

11. Install differential case assembly with side bearing outer races into gear carrier.

12. Insert left and right side bearing adjusting washers in place between side bearing and carrier.

13. Drive in side bearing spacer with Tool.

Tool number: KV38100600 (J25267)

14. Align mark on bearing cap with that on gear carrier and install bearing cap on gear carrier.

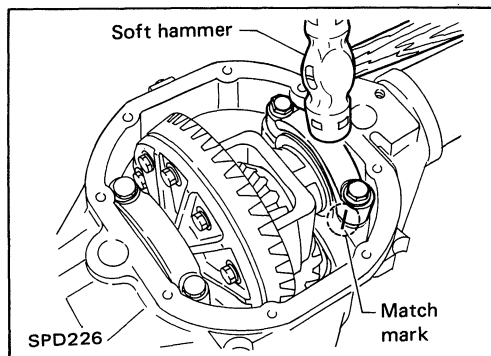
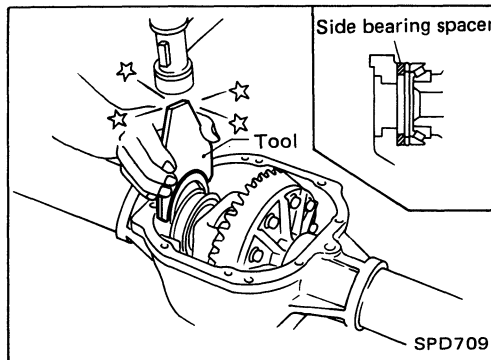
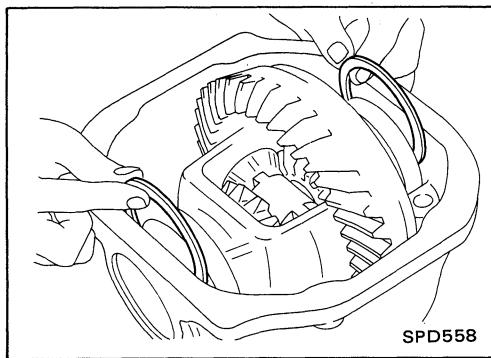
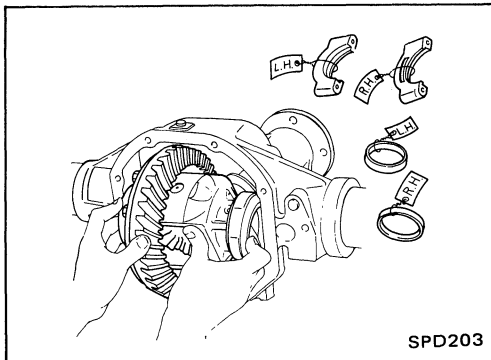
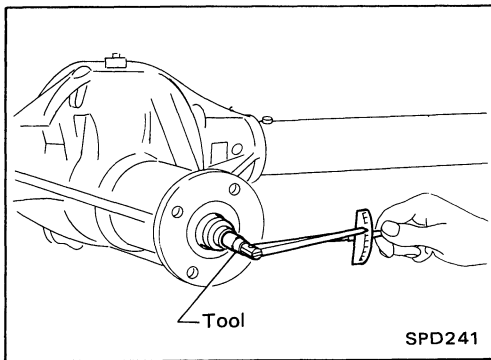

ASSEMBLY (Model C200)

Differential Carrier (Cont'd)

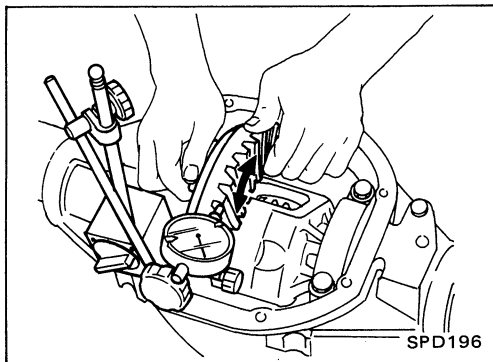

15. Measure ring gear-to-drive pinion backlash with a dial indicator.

Ring gear-to-drive pinion backlash:

0.13 - 0.18 mm

(0.0051 - 0.0071 in)

- If backlash is too small, decrease thickness of right shim and increase thickness of left shim by the same amount.

If backlash is too great, reverse the above procedure.

Never change the total amount of shims as it will change the bearing preload.

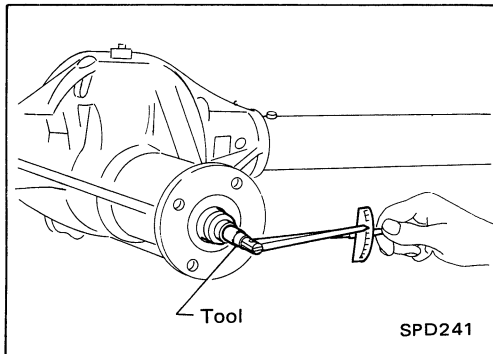

16. Check total preload with Tool.

When checking preload, turn drive pinion in both directions several times to seat bearing rollers correctly.

Total preload:

1.2 - 2.3 N·m

(12 - 23 kg·cm, 10 - 20 in·lb)

Tool number: ST3127S000 (See J25765-A)

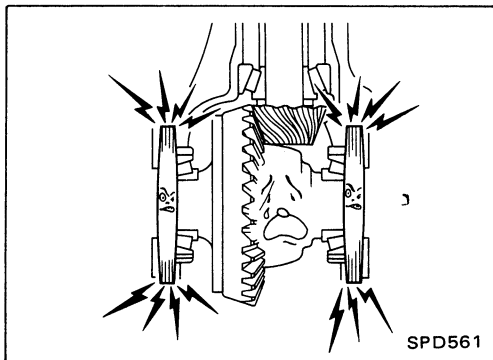

- If preload is too great, remove the same amount of shim from each side.

- If preload is too small, add the same amount of shim to each side.

Never add or remove a different number of shims for each side as it will change ring gear-to-drive pinion backlash.

17. Recheck ring gear-to-drive pinion backlash because increase or decrease in thickness of shims will cause change of ring gear-to-pinion backlash.

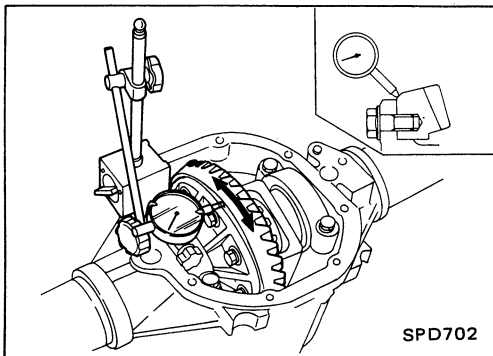

18. Check runout of ring gear with a dial indicator.

Runout limit:

0.08 mm (0.0031 in)

- If backlash varies excessively in different places, the variance may have resulted from foreign matter caught between the ring gear and the differential case.

- If the backlash varies greatly when the runout of the ring gear is within a specified range, the hypoid gear set or differential case should be replaced.

19. Check tooth contact.

Refer to Adjustment.

20. Install rear cover and gasket.

PD-100

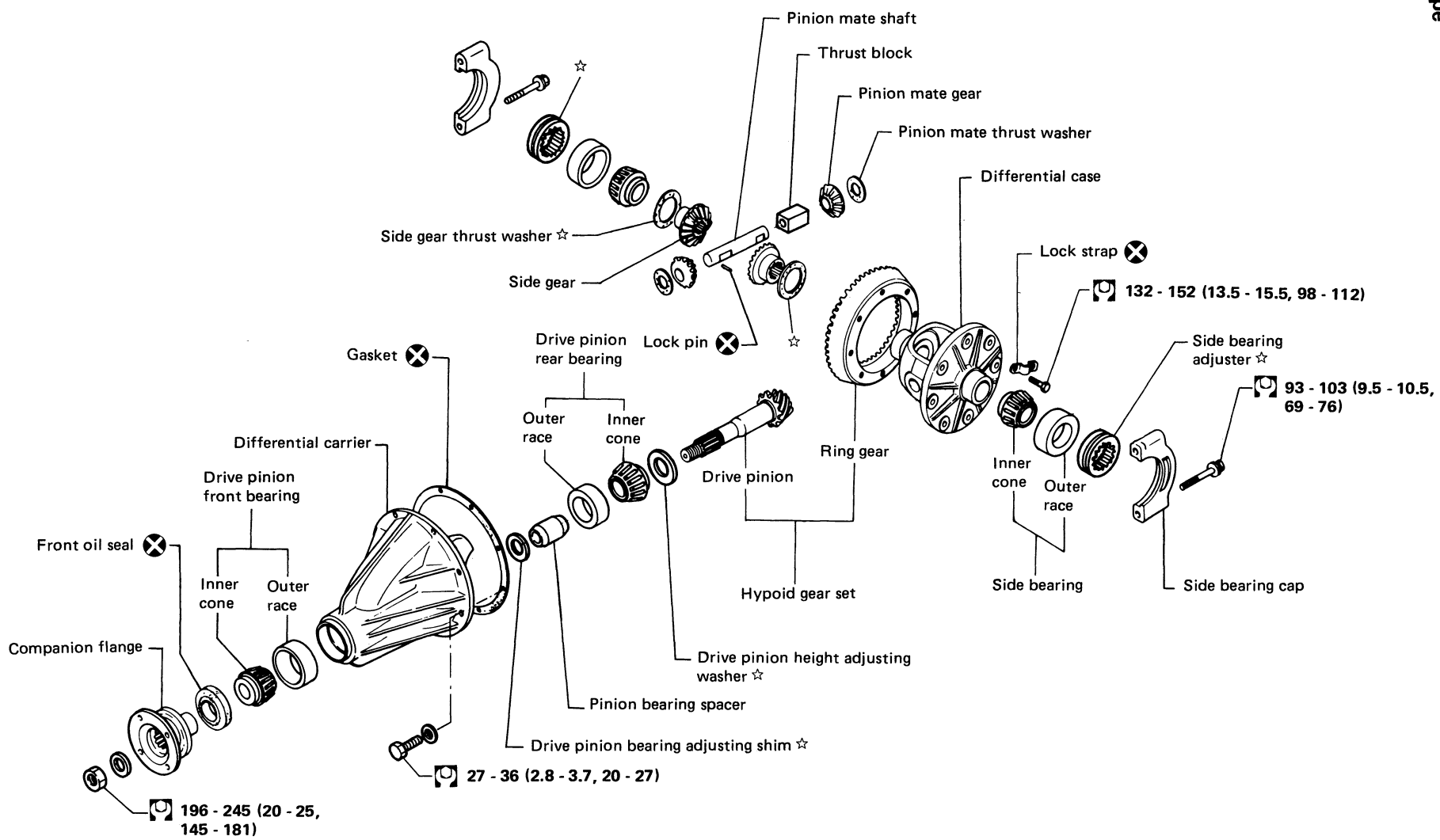

- ⊗ : N·m (kg-m, ft-lb)
- ⊗ : Always replace when disassembled.
- ☆ : Adjustment is required.

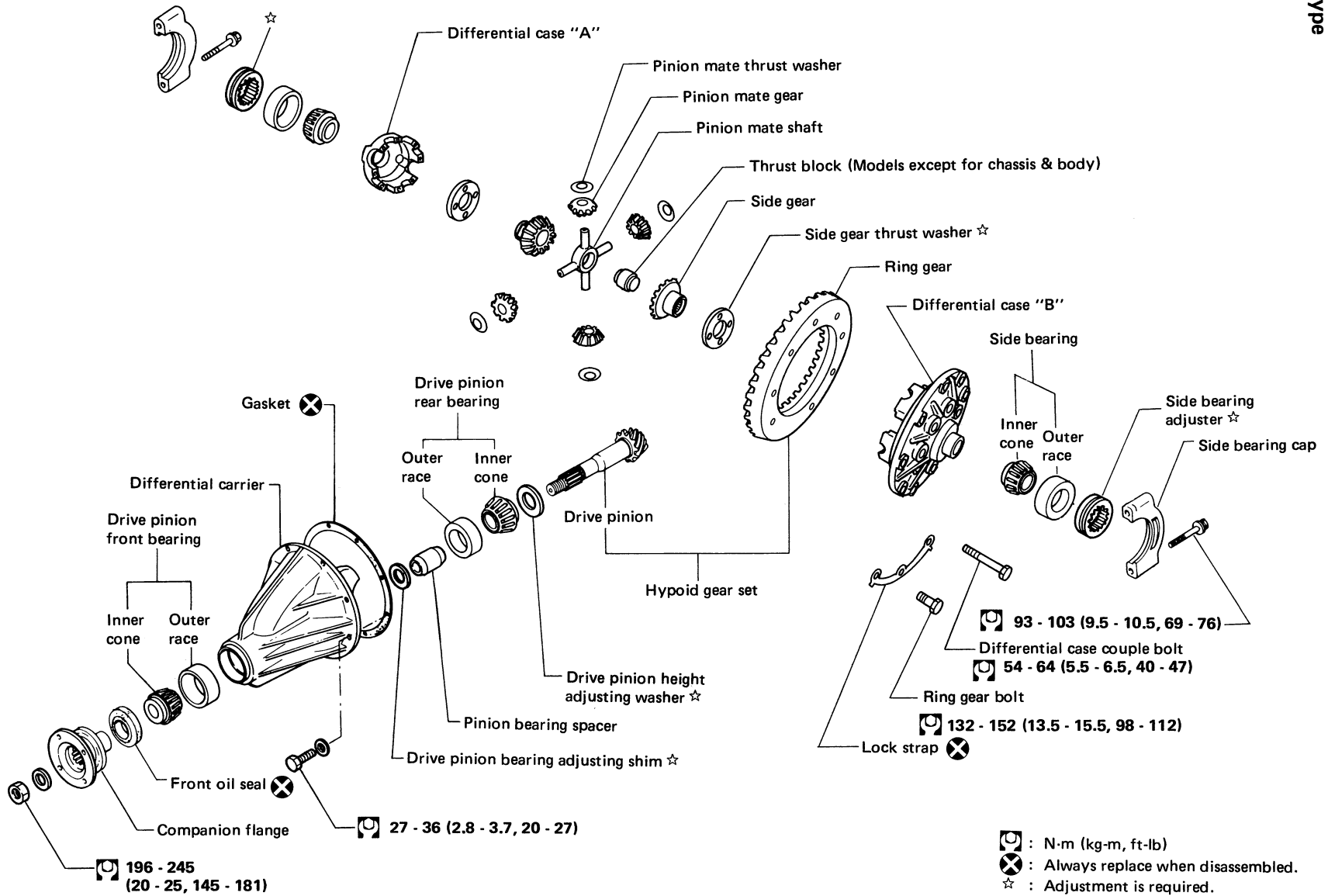

PD-101

SPD785

DISASSEMBLY (Model H233B)

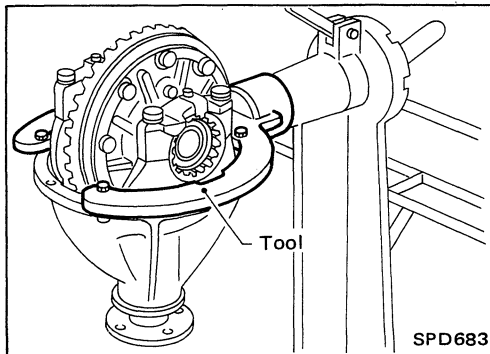
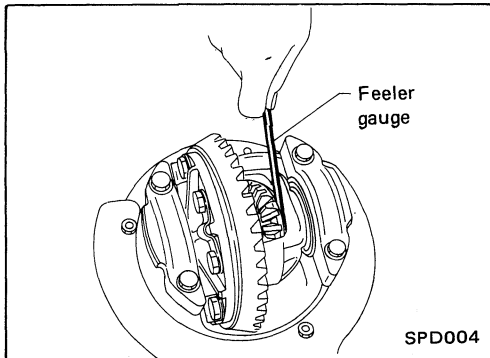
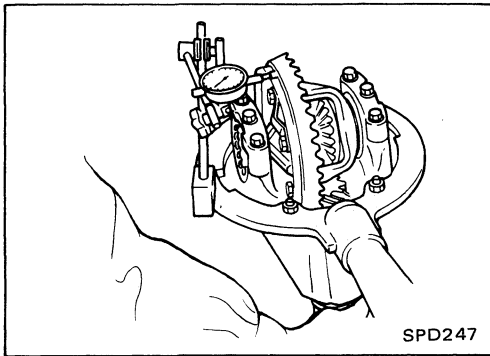
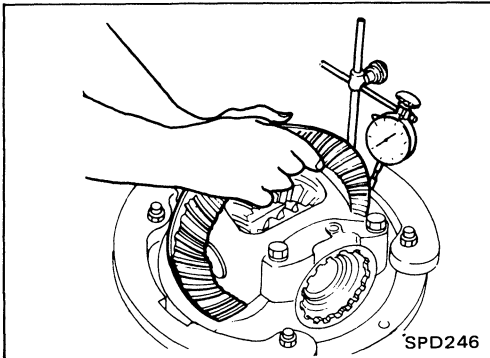
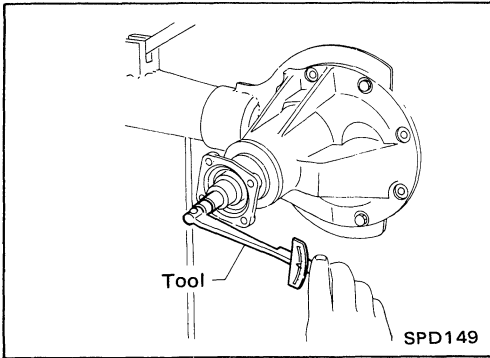

Pre-inspection

Before disassembling final drive, perform the following inspection.

- Total preload
 - 1) Turn drive pinion in both directions several times to seat bearing rollers correctly.
 - 2) Check total preload with Tool.

Total preload:

1.0 - 2.0 N·m

(10 - 20 kg·cm, 8.7 - 17.4 in-lb)

Tool number: ST3127S000 (See J25765-A)

- Ring gear to drive pinion backlash
Check backlash of ring gear with a dial indicator at several points.

Ring gear-to-drive pinion backlash:

0.15 - 0.20 mm (0.0059 - 0.0079 in)

- Ring gear runout
Check runout of ring gear with a dial indicator.

Runout limit:

0.08 mm (0.0031 in)

- Tooth contact
Check tooth contact, referring to ADJUSTMENT.
- Side gear to pinion mate gear backlash
Measure clearance between side gear thrust washer and differential case with a feeler gauge.

Clearance between side gear thrust washer and differential case:

0.10 - 0.20 mm (0.0039 - 0.0079 in)

Differential Carrier

1. Mount final drive assembly on Tool.

Tool number: ST06340000 (-)

Equivalent tool (J25602-3), (J34310)

DISASSEMBLY (Model H233B)

Differential Carrier (Cont'd)

- Put match marks on one side of side bearing cap with paint or punch to ensure that it is replaced in proper position during reassembly.

Bearing caps are line-bored during manufacture and should be put back in their original places.

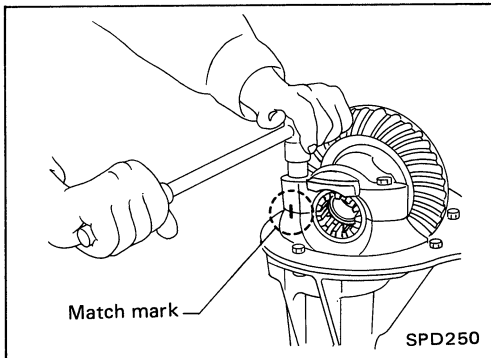
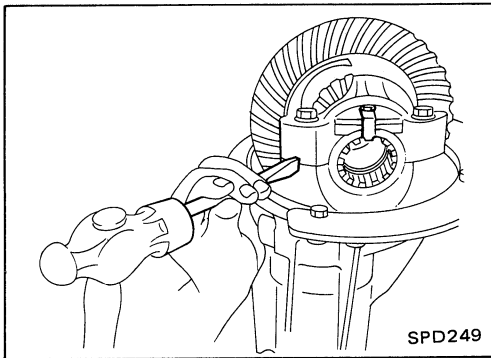

- Remove side lock fingers and side bearing caps.

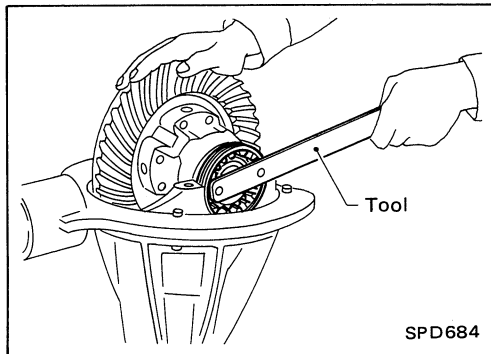

- Remove side bearing adjuster with Tool.
Tool number: ST32580000 (J34312)

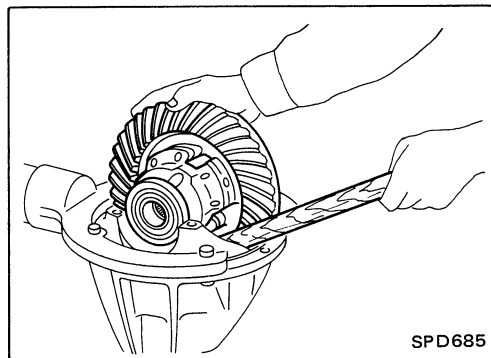

- Remove differential case assembly with a pry bar.

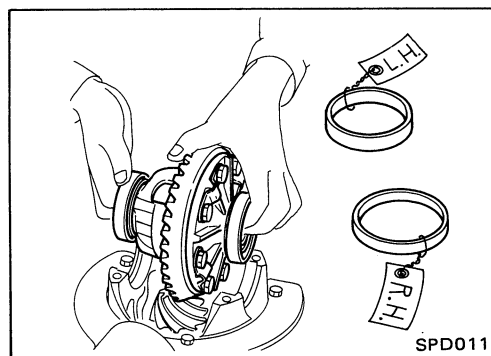

Be careful to keep the side bearing outer races together with their respective inner cones – do not mix them up.

DISASSEMBLY (Model H233B)

Differential Carrier (Cont'd)

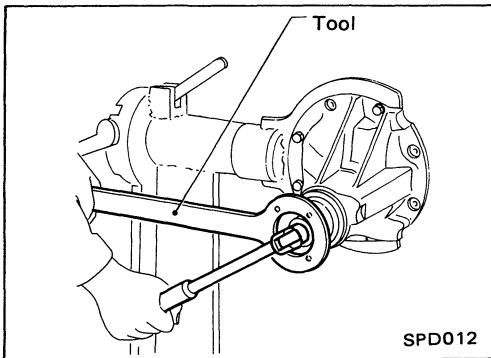

6. Remove drive pinion nut with Tool.
Tool number: KV38104700 (J34311)

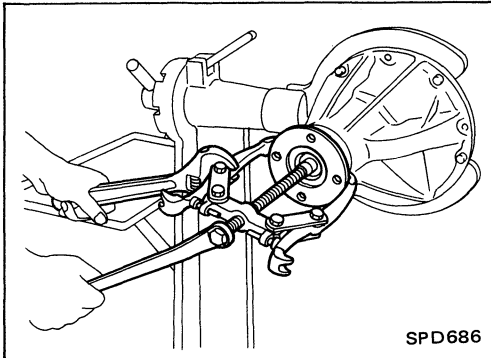

7. Remove companion flange with puller.

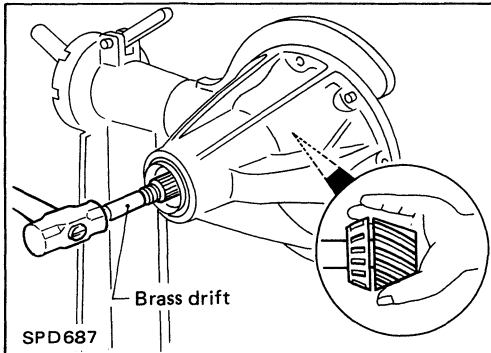

8. Take out drive pinion together with pinion rear bearing inner cone, drive pinion bearing spacer and pinion bearing adjusting shim.

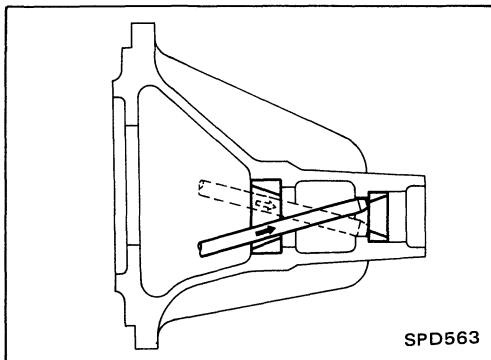

9. Remove front oil seal and pinion front bearing inner cone.
10. Remove pinion bearing outer races with a brass drift.

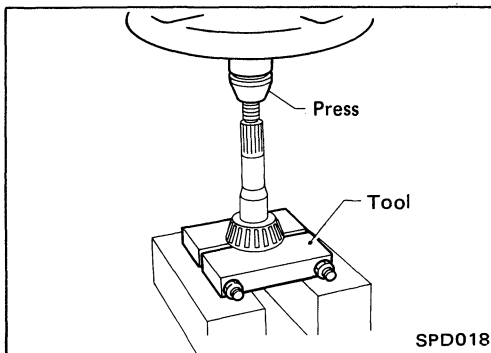

11. Remove pinion rear bearing inner cone and drive pinion adjusting washer.
Tool number: ST30031000 (J22912-01)

DISASSEMBLY (Model H233B)

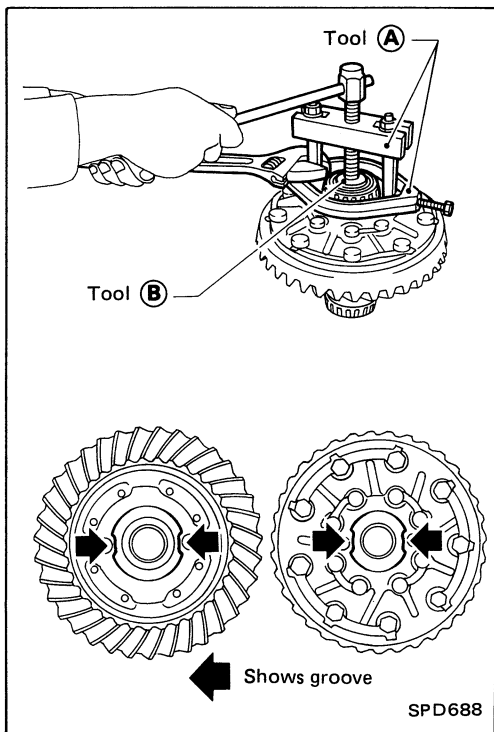

Differential Case

1. Remove side bearing inner cones.
To prevent damage to bearing, engage puller jaws in groove.

Tool number:

- Ⓐ ST33051001 (—)
Equivalent tool (J22888)
- Ⓑ ST33061000 (J8107-2)

Be careful not to confuse left and right hand parts.

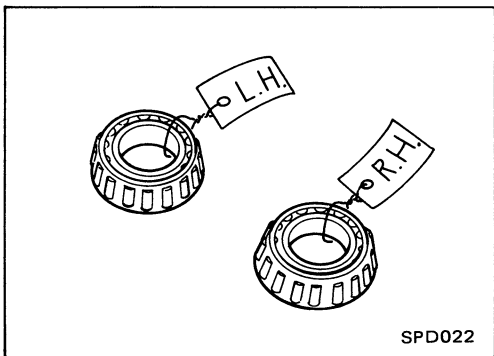

2. Spread out lock straps and loosen ring gear bolts in a criss-cross fashion.

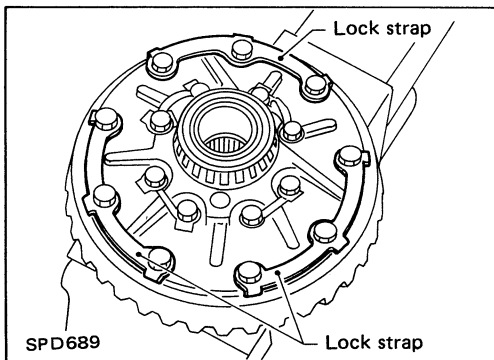

3. Tap ring gear off differential case with a soft hammer.
Tap evenly all around to keep ring gear from binding.

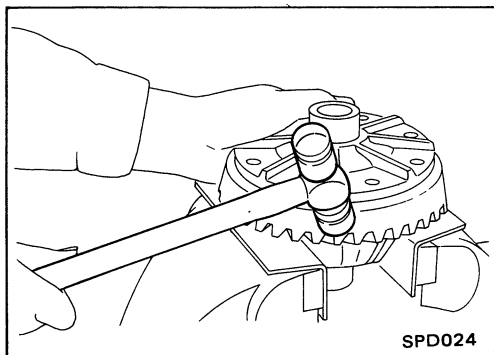

DISASSEMBLY (Model H233B)

Differential Case (Cont'd)

4. Drive out pinion mate shaft lock pin, with Tool from ring gear side (2-pinion type differential case).

Lock pin is calked at pin hole mouth on differential case.

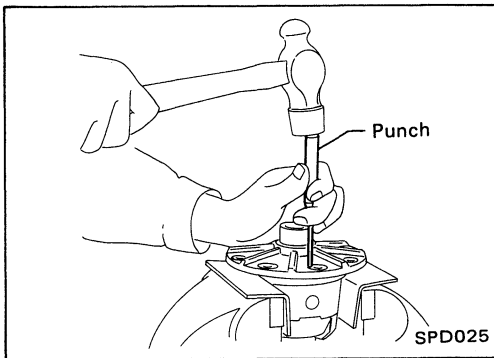

5. Separate differential case L.H. and R.H. (4-pinion type differential case).

Put match marks on both differential case L.H. and R.H. sides prior to separating them.

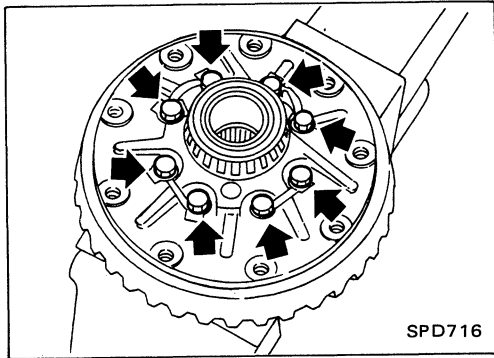

Ring Gear and Drive Pinion

Check gear teeth for scoring, cracking or chipping.
If any damaged part is evident, replace ring gear and drive pinion as a set (hypoid gear set).

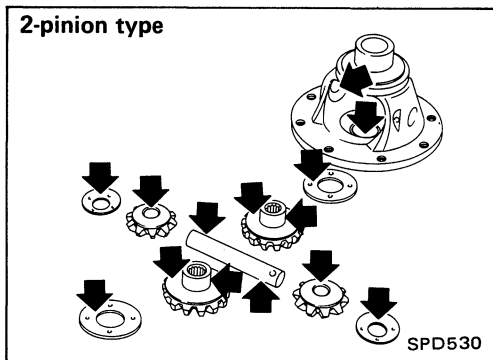

Differential Case Assembly

Check mating surfaces of differential case, side gears, pinion mate gears, pinion mate shaft, and thrust washers.

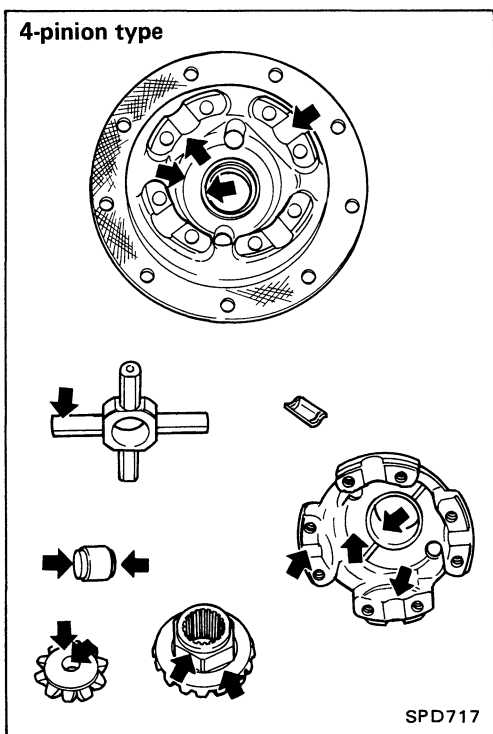

Bearing

1. Thoroughly clean bearing.
2. Check bearings for wear, scratches, pitting or flaking.
Check tapered roller bearing for smooth rotation. If damaged, replace outer race and inner cone as a set.

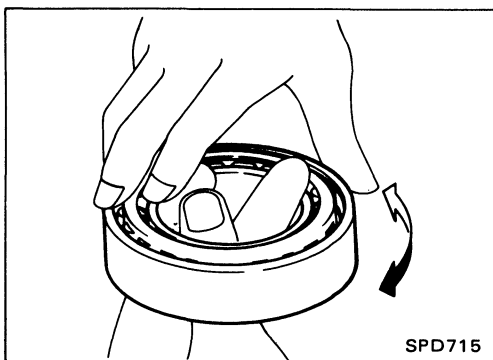

LIMITED SLIP DIFFERENTIAL (For H233B)

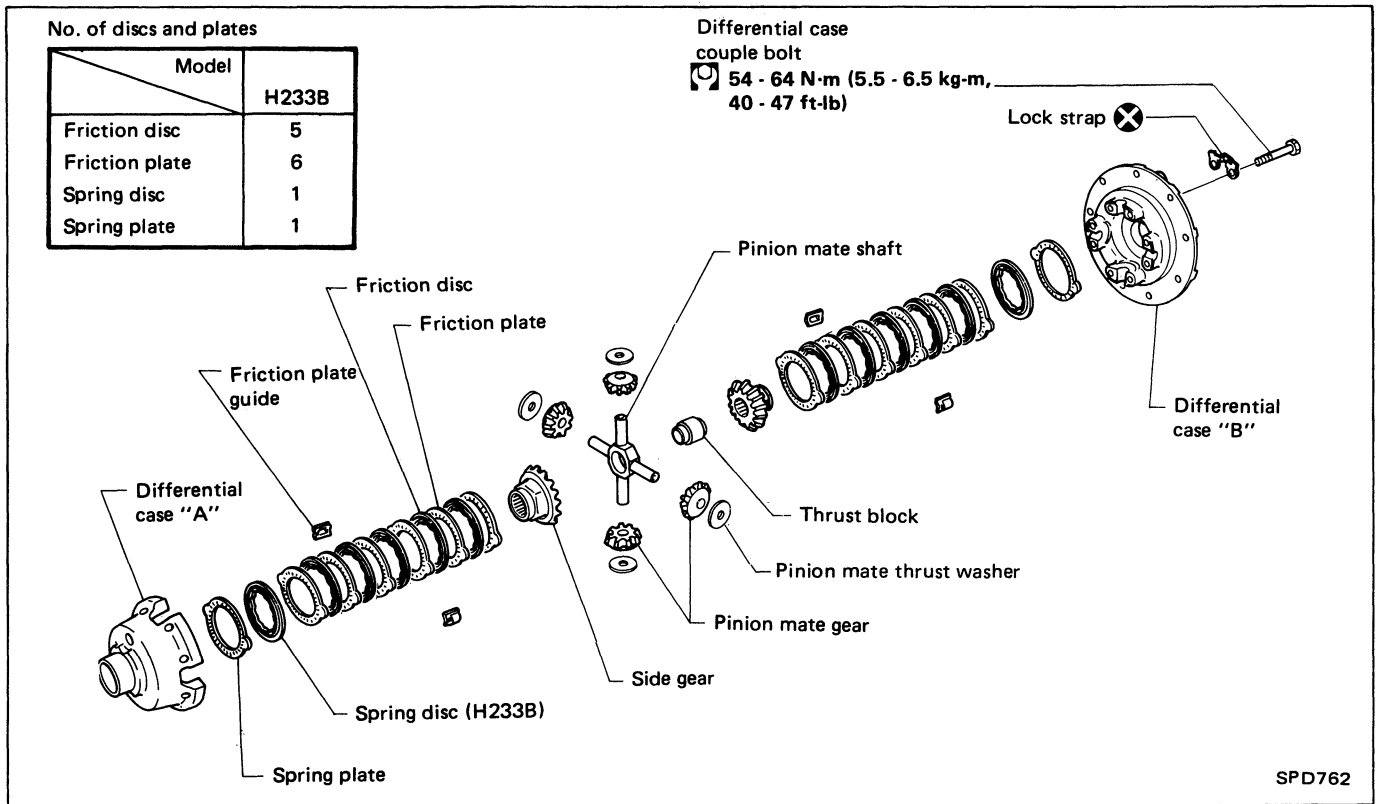

SPD762

CAUTION:

Do not run engine when one wheel (rear) is off the ground.

Preparation for Disassembly

CHECKING DIFFERENTIAL TORQUE

Measure differential torque with Tool.

If it is not within the specifications, inspect components of limited slip differential.

Differential torque:

177 - 216 N·m

(18 - 22 kg·m, 130 - 159 ft·lb)

Tool number:

Ⓐ KV38105210 (-)

Ⓑ KV38105220 (-)

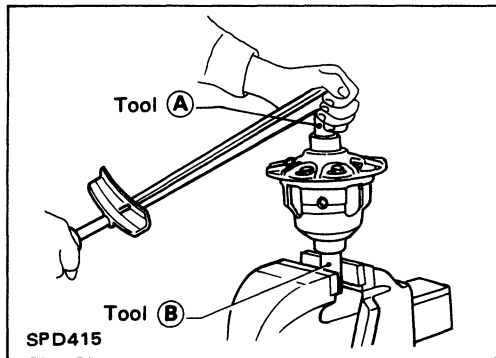

LIMITED SLIP DIFFERENTIAL (For H233B)

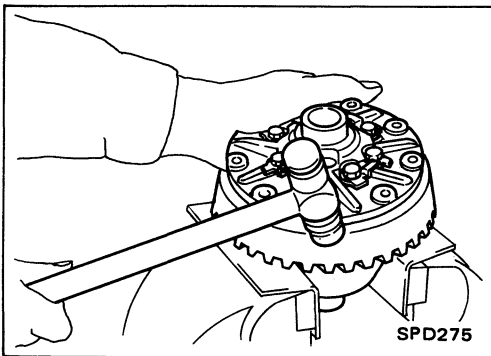

Disassembly

1. Remove side bearing inner cone with Tool.
2. Remove ring gear by spreading out lock straps.
3. Loosen ring gear bolts in a criss-cross fashion.
4. Tap ring gear off gear case with a soft hammer.
Tap evenly all around to keep ring gear from binding.

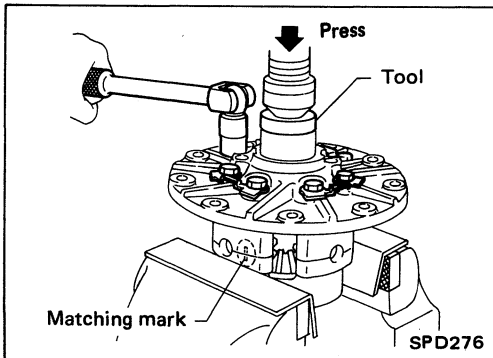

5. Remove differential case by spreading out lock straps.
6. Remove couple bolts on differential cases A and B with a press.

Tool number: ST33081000 (-)

7. Separate differential case A and B.
Draw out component parts (discs and plates, etc.).
Put marks on gears and pressure rings so that they can be reinstalled in their original positions from which they were removed.

Inspection

CONTACT SURFACES

1. Clean the disassembled parts in suitable solvent and blow dry with compressed air.
2. If following surfaces are found with burrs or scratches, smooth with oil stone.

- ① Differential case A
- ② Differential case B
- ③ Side gear
- ④ Pinion mate gear
- ⑤ Pinion mate shaft
- ⑥ Thrust block
- ⑦ Friction plate guide

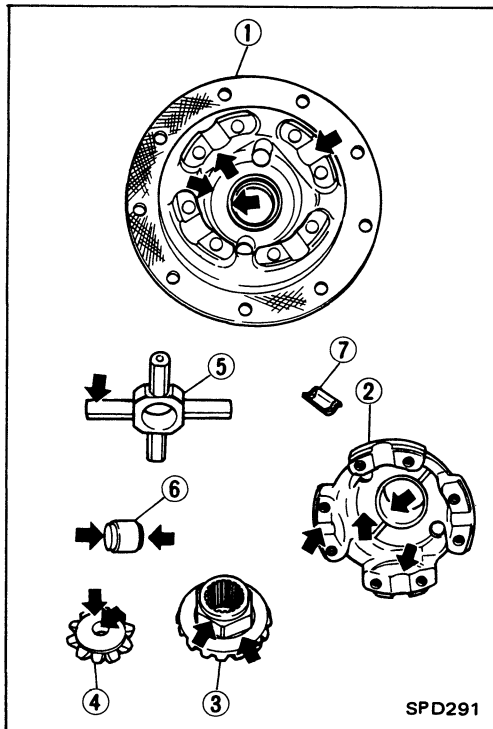

DISC AND PLATE

1. Clean the discs and plates in suitable solvent and blow dry with compressed air.
2. Inspect discs and plates for wear, nicks and burrs.

LIMITED SLIP DIFFERENTIAL (For H238B)

Inspection (Cont'd)

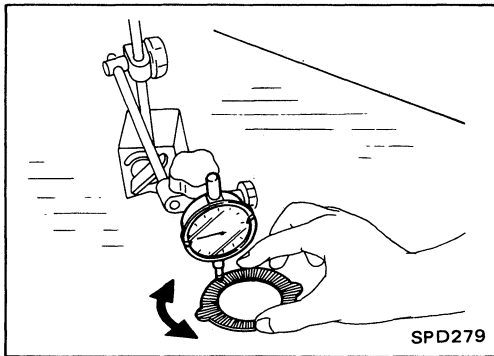

3. To test if friction disc or plate is not distorted, place it on a surface plate and rotate it by hand with indicating finger of dial gauge resting against disc or plate surface.

Allowable warpage:

0.05 - 0.15 mm (0.0020 - 0.0059 in)

If it exceeds limits, replace with a new plate to eliminate possibility of clutch slippage or sticking.

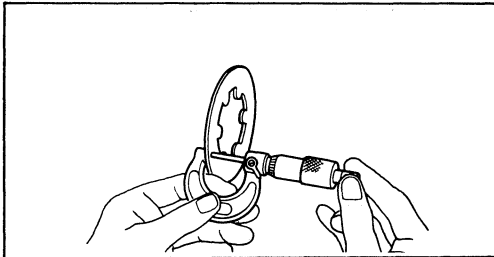

4. Measure frictional surfaces and projected portions of friction disc, friction plate, spring plate, and determine each part's differences to see if the specified wear limit has been exceeded.

5. Measure frictional surfaces and projected portions of friction disc, friction plate; spring plate and spring disc (H233B only). If any part has worn beyond the wear limit, replace it with a new one that is the same thickness as the projected portion.

Wear limit:

0.1 mm (0.004 in) or less

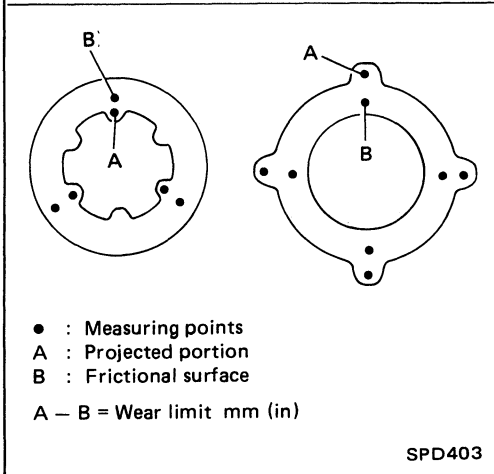

LIMITED SLIP DIFFERENTIAL (For H233B)

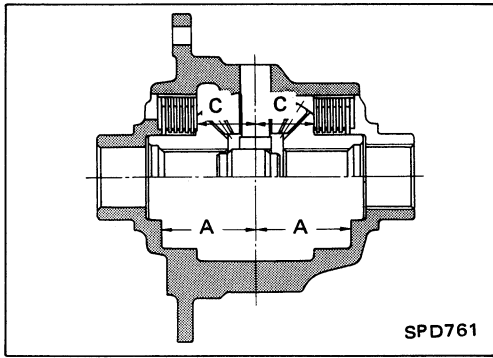

Adjustment

FRICION DISC AND FRICION PLATE END PLAY

End play of friction disc and friction plate can be calculated by using following equation and should be adjusted within following range.

Adjustment can be made by selecting friction disc having two different thicknesses.

End play E:

0.10 - 0.30 mm (0.0039 - 0.0118 in)

$$E = A - (B + C)$$

- A: Length of differential case contact surface to differential case inner bottom.
- B: Total thickness of friction discs, friction plates, spring disc and spring plate in differential case on one side.
- C: Length of differential case contact surface to back side of side gear.

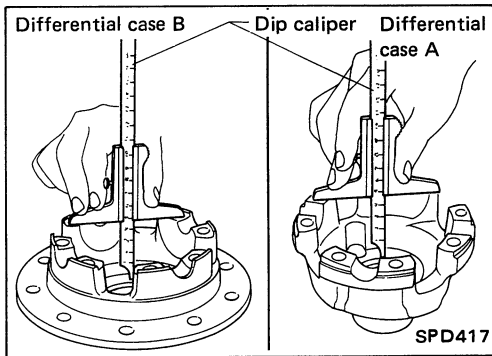

1. Measure values of "A".

Standard length A:

49.50 - 49.55 mm (1.9488 - 1.9508 in)

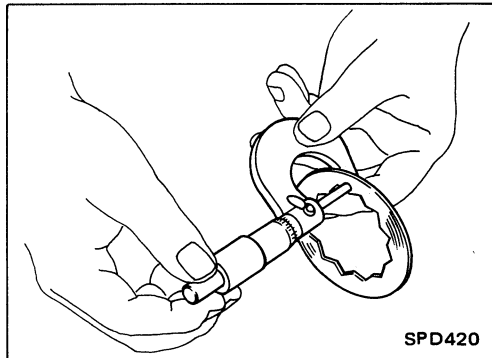

2. Measure thickness of each disc and plate.

Total thickness "B":

19.24 - 20.26 mm (0.7575 - 0.7976 in)

No. of discs and plates

Model	H233B
Friction disc	5
Friction plate	6
Spring disc	1
Spring plate	1

LIMITED SLIP DIFFERENTIAL (For H233B)

Adjustment (Cont'd)

3. Measure values of "C".

(1) Attach a dial indicator to the base plate.

(2) Place differential case B on the base plate, and install a master gauge on case B.

Then adjust the dial indicator scale to zero with its tip on the master gauge.

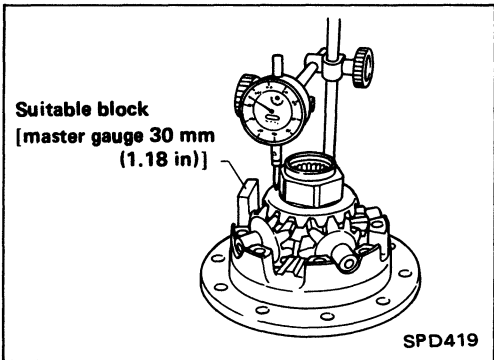
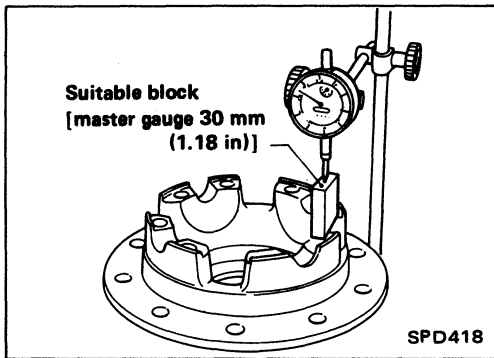

(3) Install pinion mate gears, side gears and pinion mate shaft in differential case B.

(4) Set dial indicator's tip on the side gear, and read the indication.

Example:

$$\begin{aligned} E &= A - D \\ &= A - (B + C) \\ &= 0.1 \text{ to } 0.3 \text{ mm} \end{aligned}$$

$$A = 49.52 \text{ mm}$$

$$B = 19.45 \text{ mm}$$

$$C = 29.7 \text{ mm}$$

$$D = B + C$$

$$B \dots 19.45$$

$$+ C \dots 29.7$$

$$49.15$$

$$E = A - D$$

$$A \dots 49.52$$

$$- D \dots 49.15$$

$$0.37$$

From the above equation, end play of 0.37 mm exceeds the specified range of 0.1 to 0.3 mm.

Select suitable discs and plates to adjust correctly.

Assembly

Prior to assembling discs and plates, properly lubricate them by dipping them in limited slip differential oil.

1. Alternately position specified number of friction plates and friction discs on rear of side gear.

Always position a friction plate first on rear of side gear.

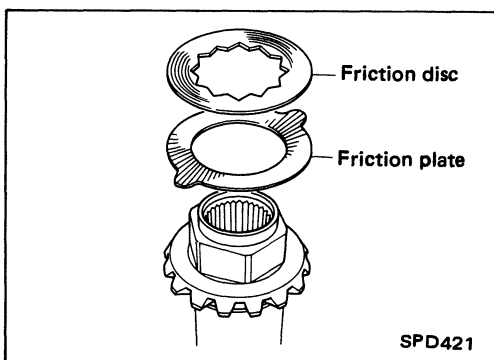

LIMITED SLIP DIFFERENTIAL (For H233B)

Assembly (Cont'd)

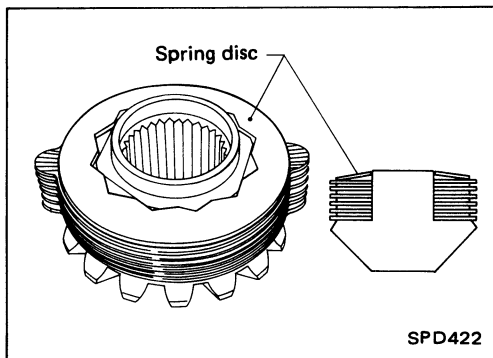

2. Install spring disc.

Align the twelve angular holes in spring disc with the hexagonal area of the side gear.

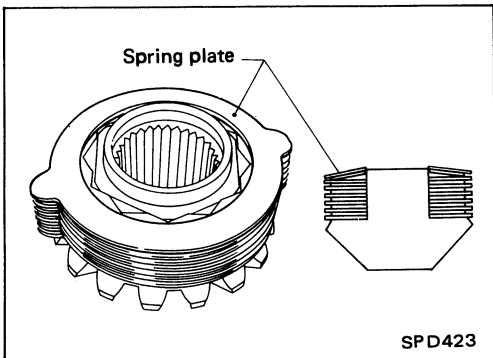

3. Install spring plate.

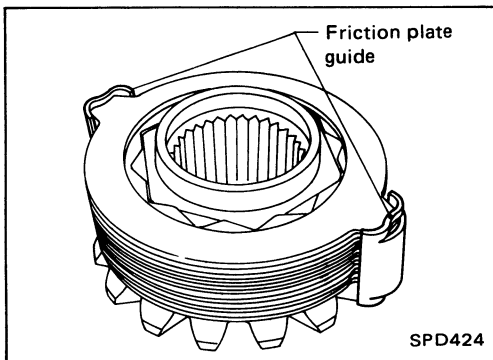

4. Install friction plate guides.

Correctly align the raised portions of friction plates, and apply grease to inner surfaces of friction plate guides to prevent them from falling.

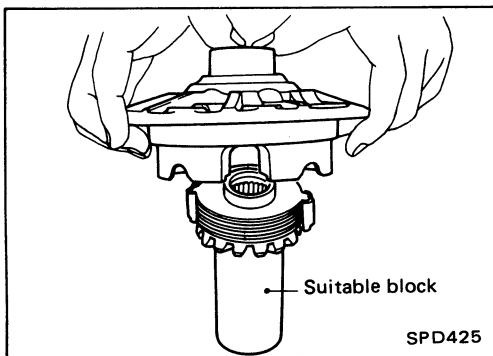

5. Install differential case B over side gear, discs, plates and friction plate guide assembly.

- Install differential case B while supporting friction plate guides with your middle finger inserted through oil hole in differential case.
- Be careful not to detach spring disc from the hexagonal part of the side gear.

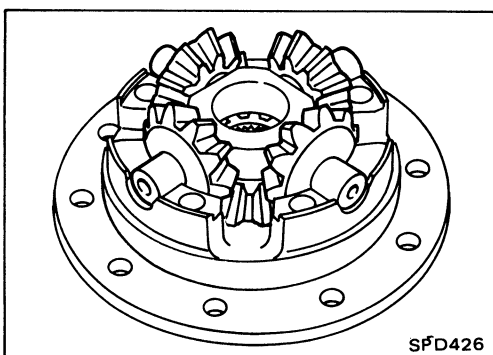

6. Install pinion mate gears and pinion shaft to differential case B.

LIMITED SLIP DIFFERENTIAL (For H233B)

Assembly (Cont'd)

7. Install thrust block.

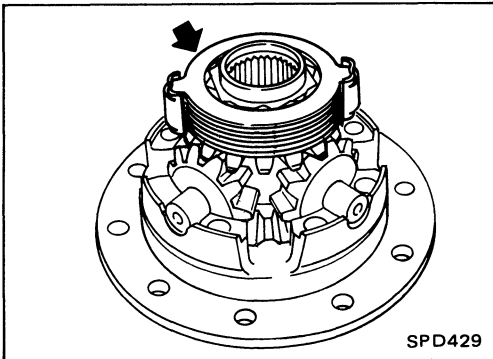
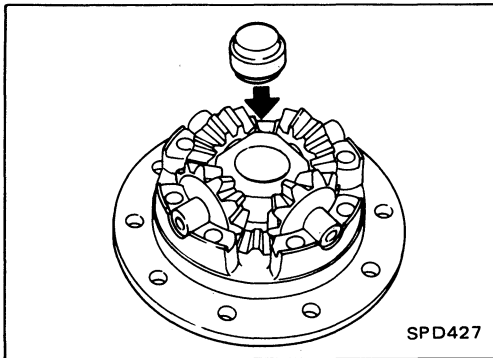

8. Install side gear to pinion mate gears.

9. Install each disc and plate.

Use same procedures as outlined in steps 1. through 4. above.

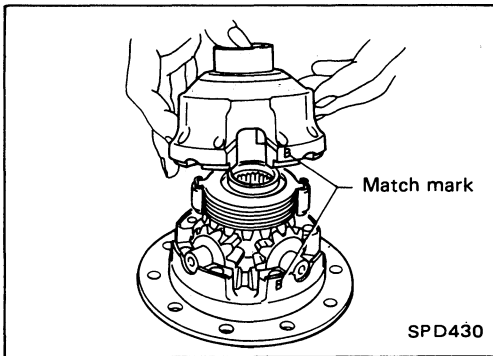

10. Install differential case A.

Position differential cases A and B by correctly aligning marks stamped on cases.

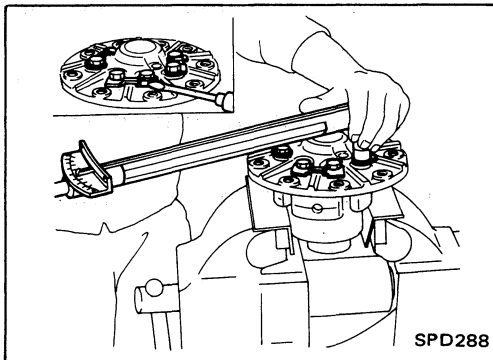

11. Tighten differential case bolts.

12. Place ring gear on differential case and install new lock straps and bolts.

Tighten bolts in a criss-cross fashion, lightly tapping bolt head with a hammer.

Then bend up lock straps to lock the bolts in place.

13. Install side bearing inner cone.

14. Check differential torque.

ADJUSTMENT (Model H233B)

For quiet and reliable final drive operation, the following five adjustments must be made correctly:

1. Pinion Bearing Preload.
2. Pinion Gear Height.
3. Side Bearing Preload.
4. Ring Gear-to-pinion Backlash. (Refer to ASSEMBLY.)
5. Ring and Pinion Gear Tooth Contact Pattern.

Pinion Bearing Preload and Pinion Gear Height

1. Make sure all parts are clean and that the bearings are well lubricated.

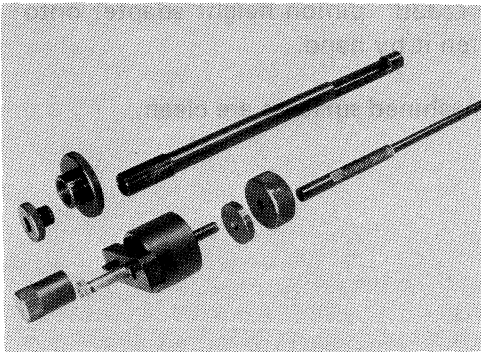

2. Assemble the pinion gear bearings into the pinion pre-load shim selector tool, J-34309.

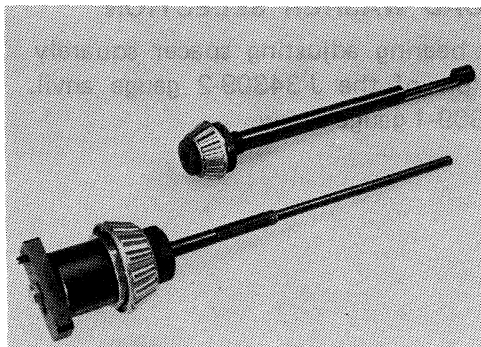

- **Rear Pinion Bearing** — the rear pinion bearing pilot, J-34309-8, is used to center the rear pinion bearing only. The rear pinion bearing locking seat, J-34309-4, is used to lock the bearing to the assembly.
- **Front Pinion Bearing** — make sure the J-34309-3, front pinion bearing seat is secured tightly against the J-34309-2 gauge anvil. Then turn the front pinion bearing pilot, J-34309-5, to secure the bearing in its proper position.

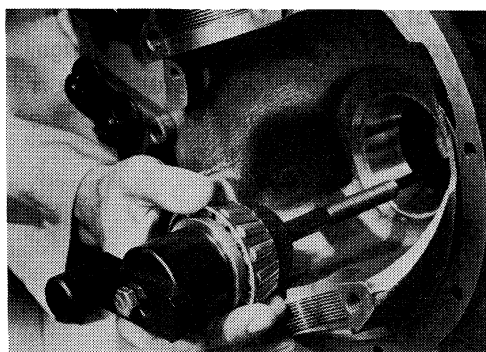

3. Place the pinion preload shim selector tool gauge screw assembly, J-34309-1, with the pinion rear bearing inner cone installed, into the final drive housing.

ADJUSTMENT (Model H233B)

Pinion Bearing Preload and Pinion Gear Height (Cont'd)

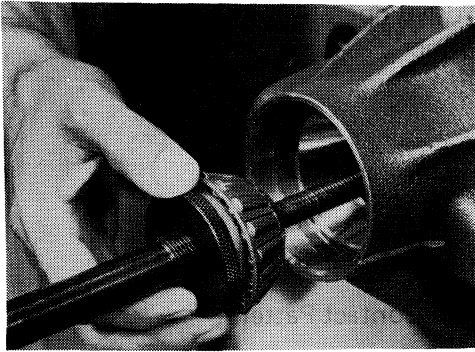

4. Install the J-34309-2 gauge anvil with the front pinion bearing into the final drive housing and assemble it to the J-34309-1 gauge screw. Make sure that the J-34309-16 gauge plate will turn a full 360 degrees, and tighten the two sections by hand to set bearing pre-load.

5. Turn the assembly several times to seat the bearings.

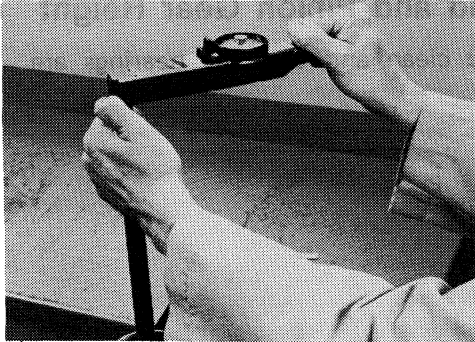

6. Measure the turning torque at the end of the J-34309-2 gauge anvil using torque wrench J-25765A.

Turning torque specification:

0.4 - 0.9 N·m (4 - 9 kg·cm, 3.5 - 7.8 in·lb)

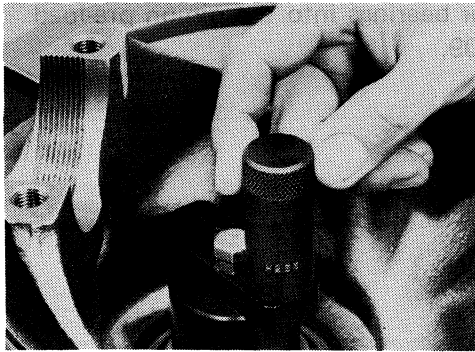

7. Place the J-34309-12 "H233B" pinion height adapter onto the gauge plate and tighten it by hand.

Caution: Make sure all machined surfaces are clean.

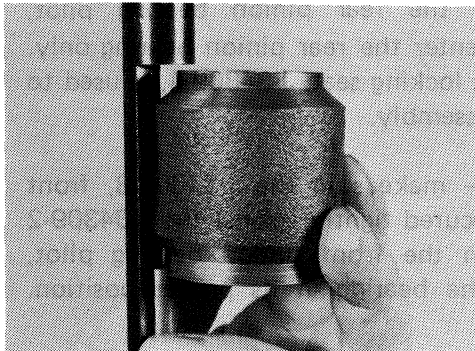

PINION BEARING PRELOAD WASHER SELECTION

8. Place the solid pinion bearing adjusting spacer squarely into the recessed portion of the J-34309-2 gauge anvil. Rest its end on the J-34309-1 gauge screw.

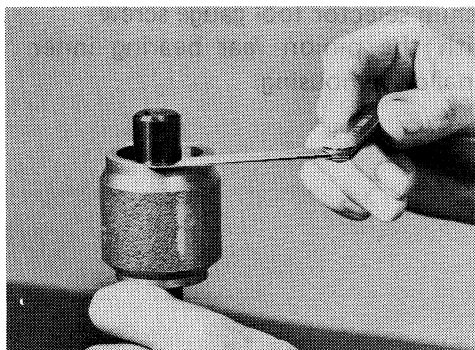

9. Select the correct thickness of pinion bearing preload adjusting washer using your J-34309-101 feeler gauge. *The exact measurement you get with your feeler gauge is the thickness of the adjusting shim required.* Select the correct shim from the following chart.

ADJUSTMENT (Model H233B)

Pinion Bearing Preload and Pinion Gear Height (Cont'd)

Drive pinion bearing preload adjusting shim (H233B)

Thickness mm (in)	Part Number
0.40 (0.0157)	24127-4301P
0.45 (0.0177)	24127-4302P
0.50 (0.0197)	24127-4303P
0.55 (0.0217)	24127-4304P
0.60 (0.0236)	24127-4305P
0.65 (0.0256)	24127-4306P
0.70 (0.0276)	24127-4307P
0.75 (0.0295)	24127-4308P

10. Set correct pinion bearing preload adjusting shim aside for use when assembling the pinion and bearings into the final drive housing.

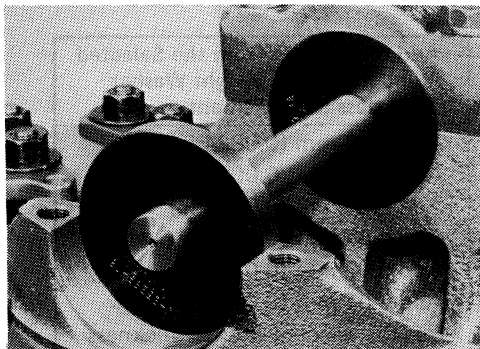

PINION HEIGHT ADJUSTING WASHER SELECTION

11. Position the J-25269-18 side bearing discs and the arbor into the side bearing bores.

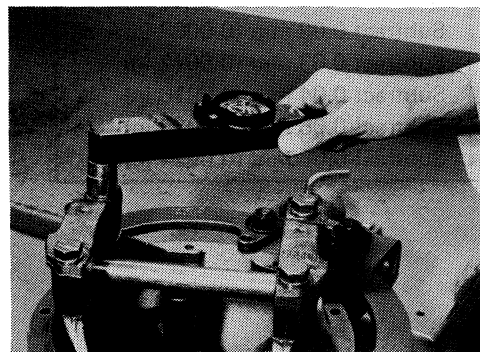

12. Install the bearing caps and torque the bolts.

Specification:

93 - 103 N-m (9.5 - 10.5 kg-m, 69 - 76 ft-lb)

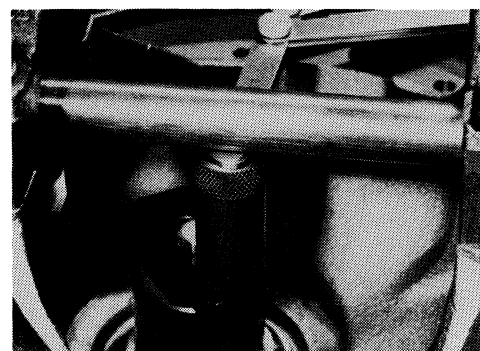

13. Select the correct *standard* pinion height adjusting washer thickness using a standard gauge of 2.5, 3.0, or 3.5 mm (0.098, 0.118, or 0.138 in) and your J-34309-101 feeler gauge. Measure the distance between the J-34309-12 "H233B" pinion height adapter and the arbor.

ADJUSTMENT (Model H233B)

Pinion Bearing Preload and Pinion Gear Height (Cont'd)

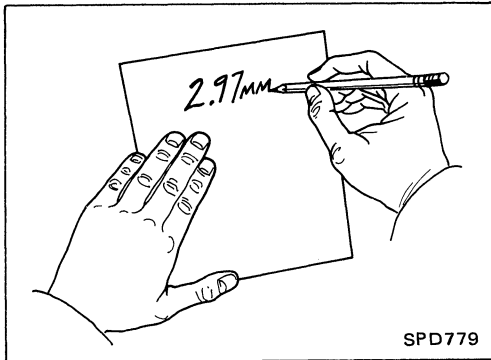

14. Write down your exact total measurement.

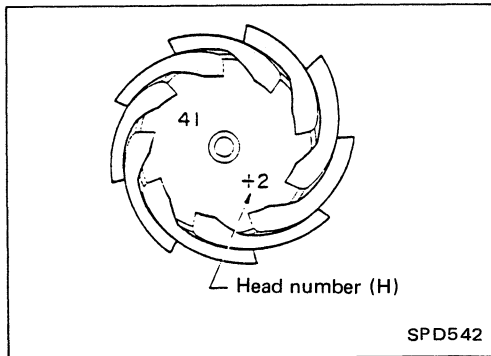

15. Correct the pinion height washer size by referring to the "pinion head height number."

Note: There are two numbers painted on the pinion gear. The first one refers to the pinion and ring gear as a matched set and should be the same as the number on the ring gear. The second number is the "pinion head height number," and it refers to the ideal pinion height from standard for the quietest operation. Use the following chart to determine the correct pinion height washer.

Pinion Head Height Number	Add or Remove from the Selected Standard Pinion Height Washer Thickness Measurement
-6	Add 0.06 mm (0.0024 in)
-5	Add 0.05 mm (0.0020 in)
-4	Add 0.04 mm (0.0016 in)
-3	Add 0.03 mm (0.0012 in)
-2	Add 0.02 mm (0.0008 in)
-1	Add 0.01 mm (0.0004 in)
0	Use the selected washer thickness
+1	Subtract 0.01 mm (0.0004 in)
+2	Subtract 0.02 mm (0.0008 in)
+3	Subtract 0.03 mm (0.0012 in)
+4	Subtract 0.04 mm (0.0016 in)
+5	Subtract 0.05 mm (0.0020 in)
+6	Subtract 0.06 mm (0.0024 in)

ADJUSTMENT (Model H233B)

Pinion Bearing Preload and Pinion Gear Height (Cont'd)

16. Select the correct pinion height washer from the following chart.

Drive pinion height adjusting washer (H233B)

Thickness mm (in)	Part number
2.58 (0.1016)	38154-P6000
2.61 (0.1028)	38154-P6001
2.64 (0.1039)	38154-P6002
2.67 (0.1051)	38154-P6003
2.70 (0.1063)	38154-P6004
2.73 (0.1075)	38154-P6005
2.76 (0.1087)	38154-P6006
2.79 (0.1098)	38154-P6007
2.82 (0.1110)	38154-P6008
2.85 (0.1122)	38154-P6009
2.88 (0.1134)	38154-P6010
2.91 (0.1146)	38154-P6011
2.94 (0.1157)	38154-P6012
2.97 (0.1169)	38154-P6013
3.00 (0.1181)	38154-P6014
3.03 (0.1193)	38154-P6015
3.06 (0.1205)	38154-P6016
3.09 (0.1217)	38154-P6017
3.12 (0.1228)	38154-P6018
3.15 (0.1240)	38154-P6019
3.18 (0.1252)	38154-P6020
3.21 (0.1264)	38154-P6021
3.24 (0.1276)	38154-P6022
3.27 (0.1287)	38154-P6023
3.30 (0.1299)	38154-P6024
3.33 (0.1311)	38154-P6025
3.36 (0.1323)	38154-P6026
3.39 (0.1335)	38154-P6027
3.42 (0.1346)	38154-P6028
3.45 (0.1358)	38154-P6029
3.48 (0.1370)	38154-P6030
3.51 (0.1382)	38154-P6031
3.54 (0.1394)	38154-P6032
3.57 (0.1406)	38154-P6033
3.60 (0.1417)	38154-P6034
3.63 (0.1429)	38154-P6035
3.66 (0.1441)	38154-P6036

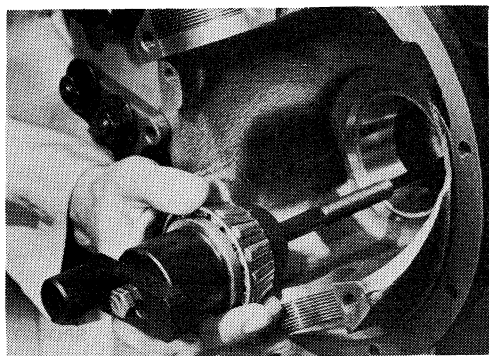

17. Remove the J-34309 pinion preload shim selector tool from the final drive housing and disassemble to retrieve the pinion bearings.

ADJUSTMENT (Model H233B)

Tooth Contact

Gear tooth contact pattern check is necessary to verify correct relationship between ring gear and drive pinion.

Hypoid gear sets which are not positioned properly in relation to one another may be noisy, or have short life or both. With a pattern check, the most desirable contact for low noise level and long life can be assured.

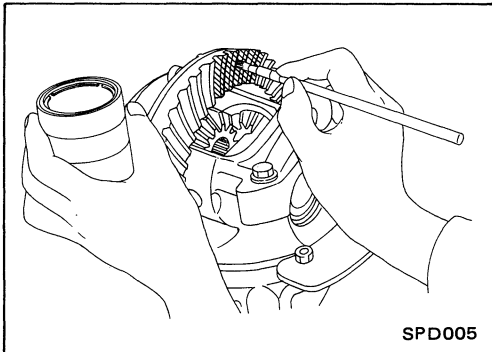

1. Thoroughly clean ring gear and drive pinion teeth.
2. Sparingly apply a mixture of powdered ferric oxide and oil or equivalent to 3 or 4 teeth of ring gear drive side.

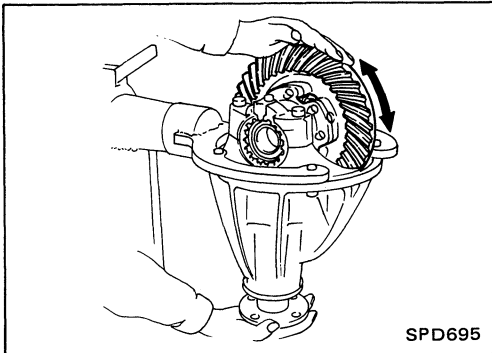

3. Hold companion flange steady by hand and rotate the ring gear in both directions.

Usually the pattern will be correct if you have calculated the shims correctly and the backlash is correct. However, in rare cases you may have to use trial-and-error processes until you get a good tooth contact pattern. The tooth pattern is the best indication of how well a differential has been set up.

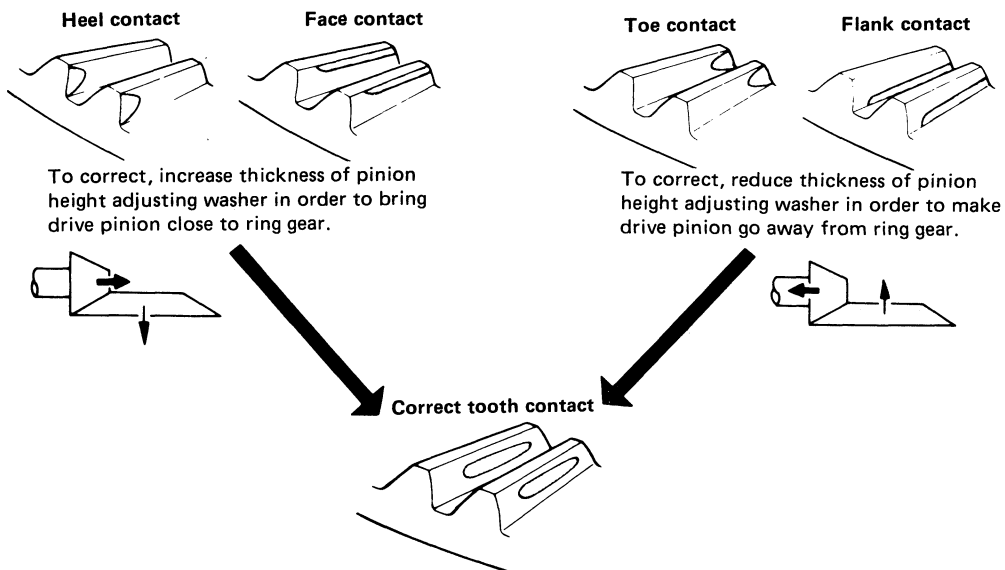

SPD007

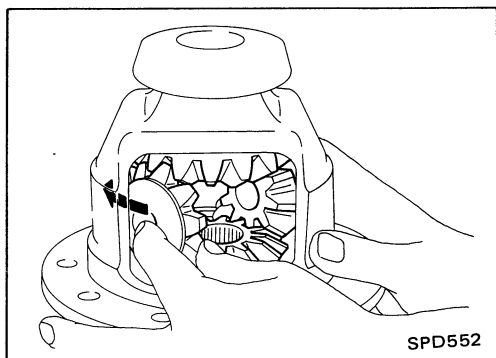

Differential Case —2-pinion type—

1. Install side gears, pinion mate gears and thrust washers into differential case.

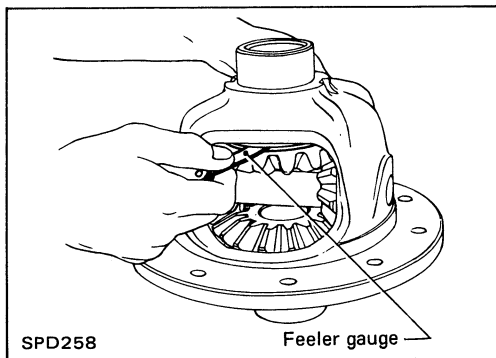

2. Fit pinion mate shaft to differential case so that it meets lock pin holes.
3. Adjust backlash between side gear and pinion mate gear by selecting side gear thrust washer. (Refer to S.D.S.)

**Backlash between side gear and pinion mate gear
(Clearance between side gear thrust washer and
differential case):**

0.10 - 0.20 mm (0.0039 - 0.0079 in)

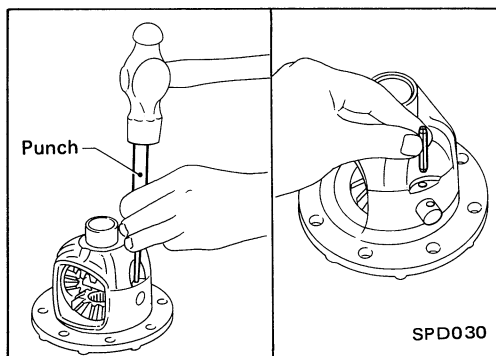

4. Install pinion mate shaft lock pin with a punch.
Make sure lock pin is flush with case.

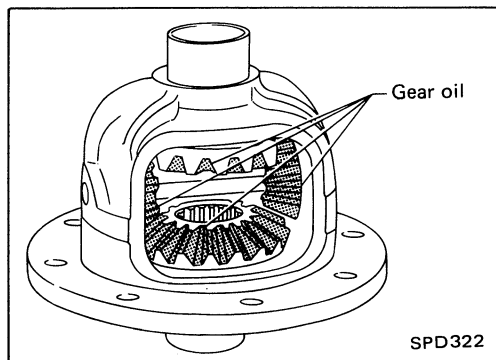

5. Apply gear oil to gear tooth surfaces and thrust surfaces and check to see they turn properly.

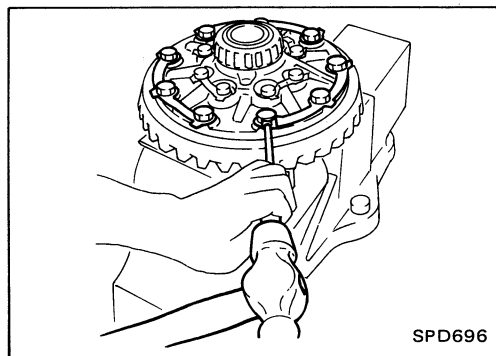

6. Install differential case assembly on ring gear.
7. Install new lock straps and ring gear bolts.
 - Tighten bolts in a criss-cross fashion, lightly tapping bolt head with a hammer.
 - Then bend up lock straps to lock the bolts in place.

ASSEMBLY (Model H233B)

Differential Case —2-pinion type— (Cont'd)

8. Press-fit side bearing inner cones on differential case with Tool.

Tool number:

- Ⓐ ST33190000 (—)
Equivalent tool (J25523)
- Ⓑ ST33081000 (—)

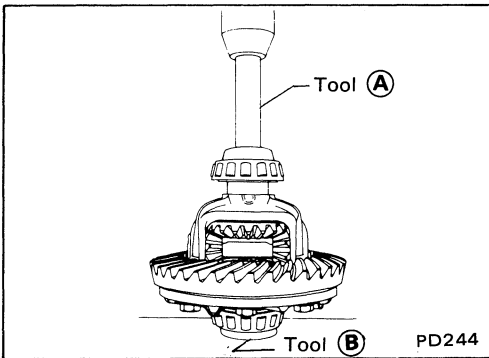

Differential Case —4-pinion type—

1. Measure clearance between side gear thrust washer and differential case.

Clearance between side gear thrust washer and differential case (A - B):

0.10 - 0.20 mm (0.0039 - 0.0079 in)

The clearance can be adjusted with side gear thrust washer. (Refer to S.D.S.)

2. Apply gear oil to gear tooth surfaces and thrust surfaces and check to see they turn properly.

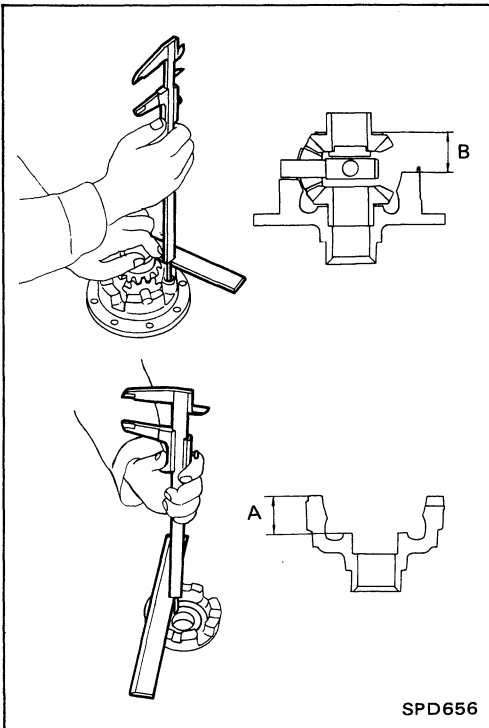

3. Install differential case L.H. and R.H.
4. Install differential case on ring gear.

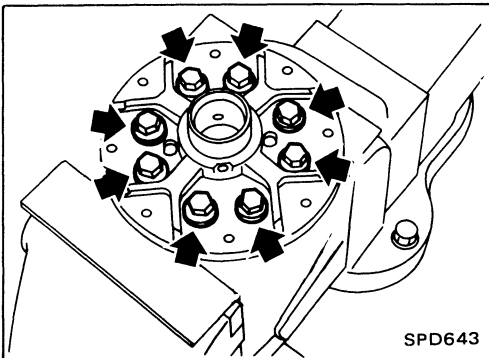

5. Place differential case on ring gear.
6. Apply locking agent [Locktite (stud lock) or equivalent] to ring gear bolts, and install them.

Tighten bolts in a criss-cross fashion, lightly tapping bolt head with a hammer.

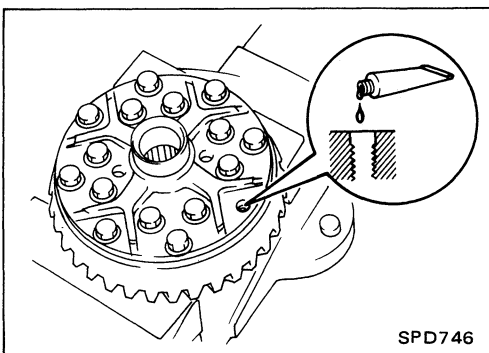

ASSEMBLY (Model H233B)

Differential Case —4-pinion type— (Cont'd)

7. Press-fit side bearing inner cones on differential case with Tool.

Tool number:

- Ⓐ ST33190000 (—)
Equivalent tool (J25523)
- Ⓑ ST33081000 (—)

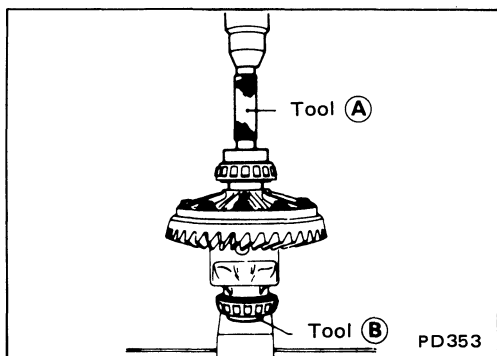

Differential Carrier

1. Press-fit front and rear bearing outer races with Tools.

Tool number:

- Ⓐ ST30611000 (J25742-1)
- Ⓑ ST30621000 (J25742-5)
- Ⓒ ST30613000 (J25742-3)

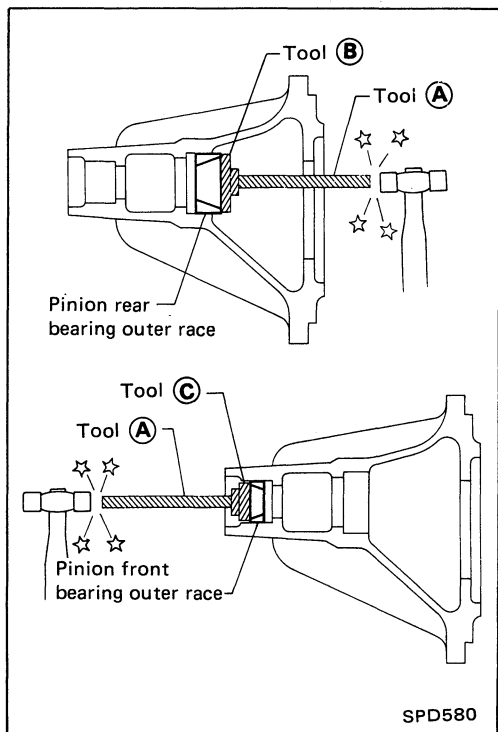

2. Select drive pinion adjusting washer, referring to ADJUSTMENT.
3. Install drive pinion adjusting washer in drive pinion, and press-fit pinion rear bearing inner cone in it with press and Tool.

Tool number: ST30901000 (—)
Equivalent tool (J26010-01)

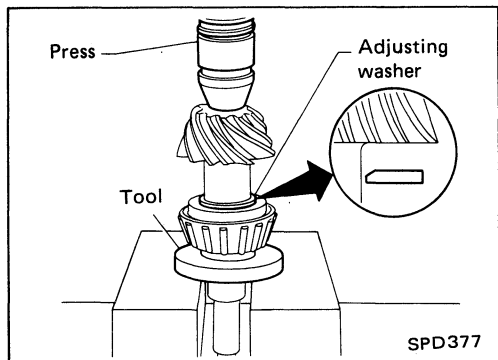

4. Place pinion front bearing inner cone in gear carrier.

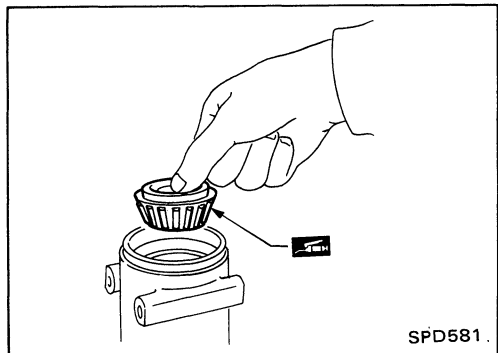

ASSEMBLY (Model H233B)

Differential Carrier (Cont'd)

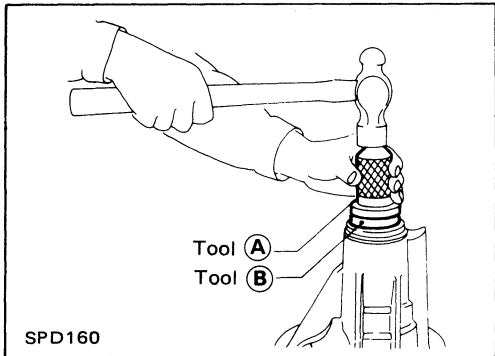

5. Apply multi-purpose grease to cavity at sealing lips of oil seal.
Install front oil seal.

Tool number:

- Ⓐ ST30720000 (-)
Equivalent tool (J25405)
- Ⓑ KV38102510 (-)

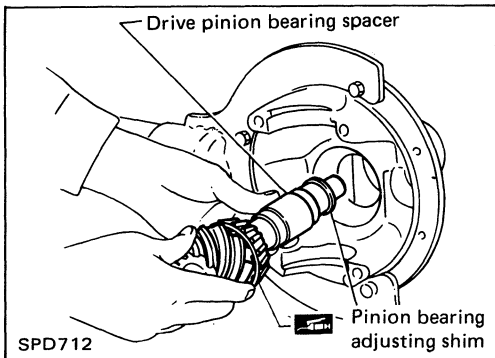

6. Install drive pinion bearing spacer, pinion bearing adjusting shim and drive pinion in gear carrier.

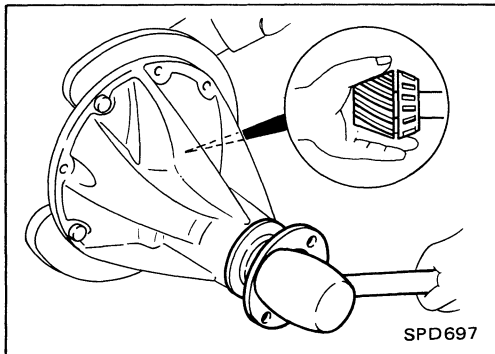

7. Insert companion flange into drive pinion by tapping the companion flange with a soft hammer.

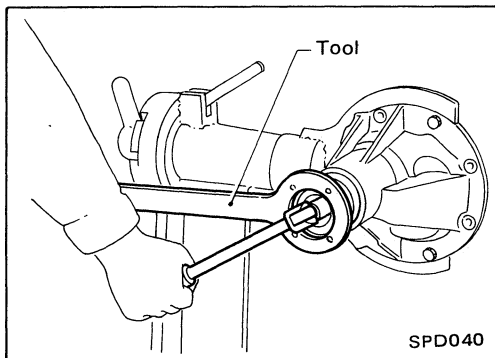

8. Tighten pinion nut to the specified torque.
The threaded portion of drive pinion and pinion nut should be free from oil or grease.

Tool number: KV38104700 (J34311)

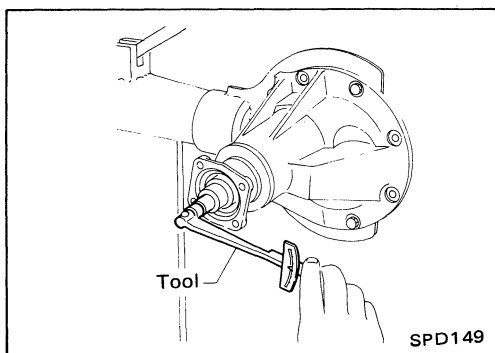

9. Turn drive pinion in both directions several times, and measure pinion bearing preload.

Tool number: ST3127S000 (See J25765-A)

Pinion bearing preload:

0.5 - 1.0 N·m
(5 - 10 kg·cm, 4.3 - 8.7 in·lb)

ASSEMBLY (Model H233B)

Differential Carrier (Cont'd)

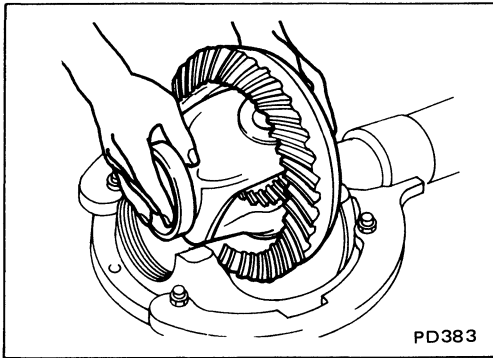

10. Install differential case assembly with side bearing outer races into gear carrier.

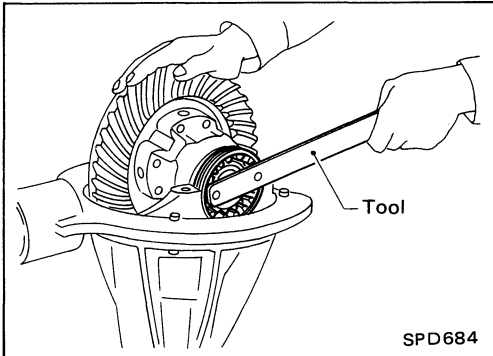

11. Position side bearing adjusters on gear carrier with threads properly engaged; screw in adjusters lightly at this stage of assembly.

Tool number: ST32580000 (J34312)

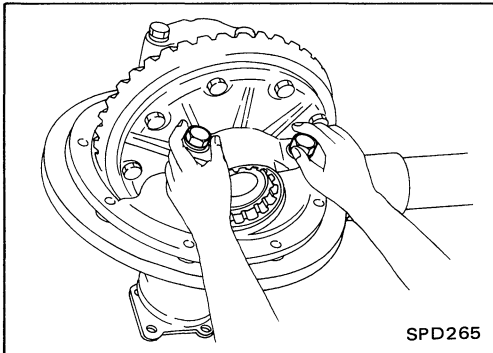

12. Align mark on bearing cap with that on gear carrier and install bearing cap on gear carrier.

- Do not tighten at this point to allow further tightening of side bearing adjusters.

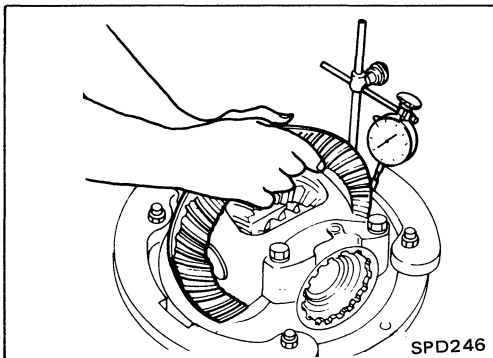

13. Tighten both right and left side bearing adjusters alternately and measure ring gear backlash and total preload at the same time. Adjust right and left side bearing adjusters by tightening them alternately so that proper ring gear backlash and total preload can be obtained.

Ring gear-to-drive pinion backlash:

0.15 - 0.20 mm (0.0059 - 0.0079 in)

- When checking preload, turn drive pinion in both directions several times to set bearing rollers.

Tool number: ST3127S000 (See J25765-A)

Total preload:

1.0 - 2.0 N·m

(10 - 20 kg-cm, 8.7 - 17.4 in-lb)

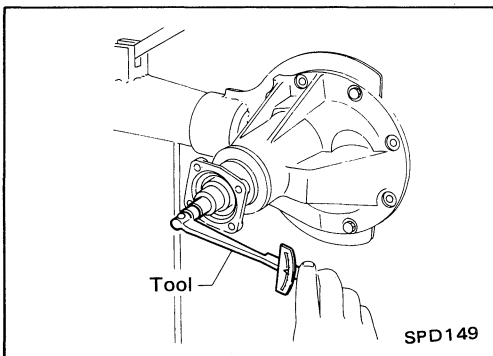

ASSEMBLY (Model H233B)

Differential Carrier (Cont'd)

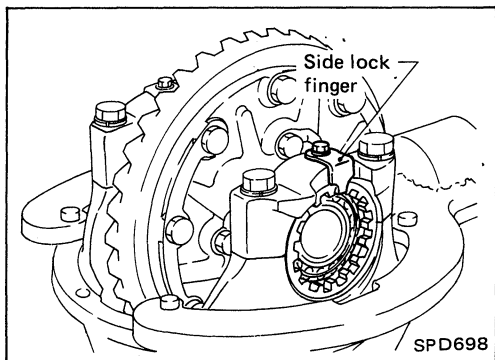

14. Tighten side bearing cap bolts.

15. Install side lock finger in place to prevent rotation during operation.

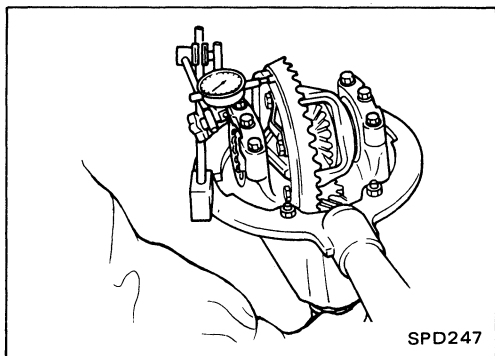

16. Check runout of ring gear with a dial indicator.

Runout limit: 0.08 mm (0.0031 in)

- If backlash varies excessively in different places, the variance may have resulted from foreign matter caught between the ring gear and the differential case.
- If the backlash varies greatly when the runout of the ring gear is within a specified range, the hypoid gear set or differential case should be replaced.

17. Check tooth contact. (Refer to ADJUSTMENT.)

GENERAL SPECIFICATIONS

Applied model	2WD								4WD							
	VG30i				Z24i				Front propeller shaft			Rear propeller shaft				
	M/T		A/T		M/T		A/T		Z24i	VG30i		VG30i		Z24i		
	Standard wheel-base	Long wheel-base	Standard wheel-base	Long wheel-base	Standard wheel-base	Long wheel-base	Standard wheel-base	Long wheel-base	M/T	M/T	A/T	Standard wheel-base	Long wheel-base	Standard wheel-base	Long wheel-base	
Model	3S80B				3S63A				2F63H	2F71H		2S80B	3S80B	2S71H	3S71H	
Number of joints	3				3				2			2	3	2	3	
Coupling method with transmission	Sleeve type								Flange type			Sleeve type				
Distance between yokes mm (in)	80 (3.15)				63 (2.48)				63 (2.48)	71 (2.80)		80 (3.15)		71 (2.80)		
Type of journal bearing	Solid type (Disassembly type)				Shell type (Non-disassembly type)				Solid type (Disassembly type)							
Shaft length (Spider to spider)																
1st mm (in)	690 (27.17)		590 (23.23)		669 (26.34)		569 (22.40)		546 (21.50)	542 (21.34)	540 (21.26)	950 (37.40)	430 (16.93)	965 (37.99)	420 (16.54)	
2nd mm (in)	660 (25.98)	960 (37.80)	660 (25.98)	960 (37.80)	687 (27.05)	987 (38.86)	687 (27.05)	987 (38.86)	-	-		-	819 (32.24)	-	842 (33.15)	
Shaft outer diameter																
1st mm (in)	75 (2.95)				75 (2.95)				63.5 (2.500)	65 (2.56)	50.8 (2.000)	65 (2.56)		75 (2.95)		
2nd mm (in)	65 (2.56)				63.5 (2.500)				-	-		-	65 (2.56)	-	65 (2.56)	

PD-127

Propeller Shaft

SERVICE DATA AND SPECIFICATIONS (S.D.S.)

SERVICE DATA AND SPECIFICATIONS (S.D.S.)

Propeller Shaft (Cont'd)

SERVICE DATA

Unit: mm (in)

Propeller shaft runout limit	0.6 (0.024)
Journal axial play	0 (0)
3S63A	0.2 (0.008) or less
3S63H	0.2 (0.008) or less
2S80B, 3S80B	0.2 (0.008) or less
2F71H, 2F63H	0.2 (0.008) or less

Snap ring (63H)

Unit: mm (in)

Thickness	Color	Part number
2.00 (0.0787)	White	37146-14600
2.02 (0.0795)	Yellow	37147-14600
2.04 (0.0803)	Red	37148-14600
2.06 (0.0811)	Green	37149-14600
2.08 (0.0819)	Blue	37150-14600
2.10 (0.0827)	Light brown	37151-14600
2.12 (0.0835)	No paint	37152-14600

Snap ring (80B)

Unit: mm (in)

Thickness	Color	Part number
1.49 (0.0587)	White	39646-21001
1.52 (0.0598)	Yellow	39647-21001
1.55 (0.0610)	Red	39648-21001
1.58 (0.0622)	Green	39649-21001
1.61 (0.0634)	Blue	39646-21002
1.64 (0.0646)	Light brown	39647-21002
1.67 (0.0657)	Black	39648-21002

Snap ring (71H)

Unit: mm (in)

Thickness	Color	Part number
1.49 (0.0587)	White	37146-01G00
1.52 (0.0598)	Yellow	37147-01G00
1.55 (0.0610)	Red	37148-01G00
1.58 (0.0622)	Green	37149-01G00
1.61 (0.0634)	Blue	37150-01G00
1.64 (0.0646)	Light brown	37151-01G00
1.67 (0.0657)	No paint	37152-01G00

TIGHTENING TORQUE

Unit	N-m	kg-m	ft-lb
Propeller shaft to differential carrier			
63A, 63H, 71H (Truck)	39 - 44	4.0 - 4.5	29 - 33
80B, 71H (Wagon)	78 - 88	8 - 9	58 - 65
Propeller shaft 1st tube to 2nd tube			
63A, 71H	34 - 44	3.5 - 4.5	25 - 33
80B	78 - 88	8 - 9	58 - 65
Center bearing locking nut			
63A, 71H	245 - 294	25 - 30	181 - 217
80B	235 - 275	24 - 28	174 - 203
Center bearing bracket to body	16 - 22	1.6 - 2.2	12 - 16

SERVICE DATA AND SPECIFICATIONS (S.D.S.)

Differential Carrier

GENERAL SPECIFICATIONS

Item	Applied model		Truck								Van & Wagon					
			2WD				4WD				4WD					
	VG30i engine		Z24i engine		VG30i engine		Z24i engine		VG30i engine		VG30i engine				Z24i engine	
	M/T	A/T	M/T	A/T	M/T		M/T		A/T		M/T		A/T		M/T	
				Front	Rear	Front	Rear	Front	Rear	Front	Rear	Front	Rear	Front	Rear	
Final drive model	H233B		H190A		R200A	H233B	R180A	C200	R200A	H233B	R200A	H233B	R200A	H233B	R180A	C200
Ring gear pitch diameter mm (in)	233 (9.17)		190 (7.48)		200 (7.87)	233 (9.17)	180 (7.09)	200 (7.87)	200 (7.87)	233 (9.17)	200 (7.87)	233 (9.17)	200 (7.87)	233 (9.17)	180 (7.09)	200 (7.87)
Gear ratio	3.700	3.900	3.700	3.889	4.375*3		4.375		4.375*1 4.625*3		4.375		4.375*3 4.625*2		4.625	
Number of teeth (Ring gear/Drive pinion)	37/10	39/10	37/10	35/9	37/9*1 35/8*2		35/8		35/8*1 37/8		35/8		35/8 37/8*2		37/8	
Oil capacity (approx.) ℓ (US qt, Imp qt)	2.8 (3, 2-1/2)		1.5 (1-5/8, 1-3/8)		1.5 (1-5/8, 1-3/8)	2.8 (3, 2-1/2)	1.3 (1-3/8, 1-1/8)		1.5 (1-5/8, 1-3/8)	2.8 (3, 2-1/2)	1.5 (1-5/8, 1-3/8)	2.8 (3, 2-1/2)	1.5 (1-5/8, 1-3/8)	2.8 (3, 2-1/2)	1.3 (1-3/8, 1-1/8)	

*1: ST

*2: SE

*3: L.S.D. is optional as sports package.

SERVICE DATA (R180A)

Model	R180A	
Drive pinion bearing preload adjusting method	Adjusting spacer and washer	
Drive pinion preload (With front oil seal) N·m (kg-cm, in-lb)	0.9 - 1.7 (9 - 17, 7.8 - 14.8)	
Side bearing adjusting method	Shim	
Backlash	Drive pinion to ring gear mm (in)	0.13 - 0.18 (0.0051 - 0.0071)
	Side gear to pinion mate gear (Clearance between side gear to differential case) mm (in)	0.10 - 0.20 (0.0039 - 0.0079)
Ring gear runout limit mm (in)	0.08 (0.0031)	
Total preload N·m (kg-cm, in-lb)	1.0 - 2.3 (10 - 23, 8.7 - 20.0)	

Drive pinion height adjusting washer (R180A)

Thickness mm (in)	Part No.
3.09 (0.1217)	38154-P6017
3.12 (0.1228)	38154-P6018
3.15 (0.1240)	38154-P6019
3.18 (0.1252)	38154-P6020
3.21 (0.1264)	38154-P6021
3.24 (0.1276)	38154-P6022
3.27 (0.1287)	38154-P6023
3.30 (0.1299)	38154-P6024
3.33 (0.1311)	38154-P6025
3.36 (0.1323)	38154-P6026
3.39 (0.1335)	38154-P6027
3.42 (0.1346)	38154-P6028
3.45 (0.1358)	38154-P6029
3.48 (0.1370)	38154-P6030
3.51 (0.1382)	38154-P6031
3.54 (0.1394)	38154-P6032
3.57 (0.1406)	38154-P6033
3.60 (0.1417)	38154-P6034
3.63 (0.1429)	38154-P6035
3.66 (0.1441)	38154-P6036

SERVICE DATA AND SPECIFICATIONS (S.D.S.)

Differential Carrier (Cont'd)

Drive pinion bearing adjusting washer (R180A)

Thickness mm (in)	Part No.
6.59 (0.2594)	38127-01G00
6.57 (0.2587)	38127-01G01
6.55 (0.2579)	38127-01G02
6.53 (0.2571)	38127-01G03
6.51 (0.2563)	38127-01G04
6.49 (0.2555)	38127-01G05
6.47 (0.2547)	38127-01G06
6.45 (0.2539)	38127-01G07
6.43 (0.2531)	38127-01G08
6.41 (0.2524)	38127-01G09
6.39 (0.2516)	38127-01G10
6.37 (0.2508)	38127-01G11
6.35 (0.2500)	38127-01G12
6.33 (0.2492)	38127-01G13
6.31 (0.2484)	38127-01G14

Drive pinion bearing adjusting spacer (R180A)

Length mm (in)	Part No.
52.20 (2.0551)	38130-78500
52.40 (2.0630)	38131-78500
52.60 (2.0709)	38132-78500
52.80 (2.0787)	38133-78500
53.00 (2.0866)	38134-78500
53.20 (2.0945)	38135-78500

Side retainer adjusting shim (R180A)

Thickness mm (in)	Part No.
0.20 (0.0079)	38453-01G00
0.25 (0.0098)	38453-01G01
0.30 (0.0118)	38453-01G02
0.40 (0.0157)	38453-01G03
0.50 (0.0197)	38453-01G04

Side gear thrust washer (R180A)

Thickness mm (in)	Part No.
0.775 (0.0305)	38424-W2000
0.825 (0.0325)	38424-W2001
0.875 (0.0344)	38424-W2002
0.925 (0.0364)	38424-W2003
0.975 (0.0384)	38424-W2004

Bearing adjusting shim (R180A)

Thickness mm (in)	Part No.
0.1 (0.0039)	38233-01G11
0.2 (0.0079)	38233-01G12
0.3 (0.0118)	38233-01G13
0.4 (0.0157)	38233-01G14

SERVICE DATA (R200A)

Final drive model	R200A
Drive pinion bearing preload adjusting method	Adjusting spacer and washer
Drive pinion preload (With front oil seal) N·m (kg·cm, in·lb)	1.13 - 1.72 (11.5 - 17.5, 10.0 - 15.2)
Total preload N·m (kg·cm, in·lb)	1.23 - 2.30 (12.5 - 23.5, 10.9 - 20.4)
Side bearing adjusting method	Shim
Backlash Drive pinion to ring gear mm (in)	0.13 - 0.18 (0.0051 - 0.0071)
Side gear to pinion mate gear (Clearance between side gear to differential case) mm (in)	0.10 - 0.20 (0.0039 - 0.0079)
Ring gear runout limit mm (in)	Less than 0.05 (0.0020)

SERVICE DATA AND SPECIFICATIONS (S.D.S.)**Differential Carrier (Cont'd)****Drive pinion adjusting washer (R200A)**

Thickness mm (in)	Part No.
3.09 (0.1217)	38154-P6017
3.12 (0.1228)	38154-P6018
3.15 (0.1240)	38154-P6019
3.18 (0.1252)	38154-P6020
3.21 (0.1264)	38154-P6021
3.24 (0.1276)	38154-P6022
3.27 (0.1287)	38154-P6023
3.30 (0.1299)	38154-P6024
3.33 (0.1311)	38154-P6025
3.36 (0.1323)	38154-P6026
3.39 (0.1335)	38154-P6027
3.42 (0.1346)	38154-P6028
3.45 (0.1358)	38154-P6029
3.48 (0.1370)	38154-P6030
3.51 (0.1382)	38154-P6031
3.54 (0.1394)	38154-P6032
3.57 (0.1406)	38154-P6033
3.60 (0.1417)	38154-P6034
3.63 (0.1429)	38154-P6035
3.66 (0.1441)	38154-P6036

Drive pinion bearing adjusting spacer (R200A)

Length mm (in)	Part No.
54.50 (2.1457)	38165-B4000
54.80 (2.1575)	38165-B4001
55.10 (2.1693)	38165-B4002
55.40 (2.1811)	38165-B4003
55.70 (2.1929)	38165-B4004
56.00 (2.2047)	38165-61001

Side bearing adjusting washer (R200A)

Thickness mm (in)	Part No.
2.00 (0.0787)	38453-N3100
2.05 (0.0807)	38453-N3101
2.10 (0.0827)	38453-N3102
2.15 (0.0846)	38453-N3103
2.20 (0.0866)	38453-N3104
2.25 (0.0886)	38453-N3105
2.30 (0.0906)	38453-N3106
2.35 (0.0925)	38453-N3107
2.40 (0.0945)	38453-N3108
2.45 (0.0965)	38453-N3109
2.50 (0.0984)	38453-N3110
2.55 (0.1004)	38453-N3111
2.60 (0.1024)	38453-N3112

Drive pinion bearing adjusting washer (R200A)

Thickness mm (in)	Part No.
3.80 - 3.82 (0.1496 - 0.1504)	38125-61001
3.82 - 3.84 (0.1504 - 0.1512)	38126-61001
3.84 - 3.86 (0.1512 - 0.1520)	38127-61001
3.86 - 3.88 (0.1520 - 0.1528)	38128-61001
3.88 - 3.90 (0.1528 - 0.1535)	38129-61001
3.90 - 3.92 (0.1535 - 0.1543)	38130-61001
3.92 - 3.94 (0.1543 - 0.1551)	38131-61001
3.94 - 3.96 (0.1551 - 0.1559)	38132-61001
3.96 - 3.98 (0.1559 - 0.1567)	38133-61001
3.98 - 4.00 (0.1567 - 0.1575)	38134-61001
4.00 - 4.02 (0.1575 - 0.1583)	38135-61001
4.02 - 4.04 (0.1583 - 0.1591)	38136-61001
4.04 - 4.06 (0.1591 - 0.1598)	38137-61001
4.06 - 4.08 (0.1598 - 0.1606)	38138-61001
4.08 - 4.10 (0.1606 - 0.1614)	38139-61001

Side gear thrust washer (R200A)

Thickness mm (in)	Part No.
0.75 - 0.80 (0.0295 - 0.0315)	38424-N3100
0.80 - 0.85 (0.0315 - 0.0335)	38424-N3101
0.85 - 0.90 (0.0335 - 0.0354)	38424-N3102
0.90 - 0.95 (0.0354 - 0.0374)	38424-N3103

SERVICE DATA AND SPECIFICATIONS (S.D.S.)

Differential Carrier (Cont'd)

SERVICE DATA (H190A)

Final drive model	H190A
Drive pinion bearing preload adjusting method	Collapsible spacer
Drive pinion preload (With front oil seal) N-m (kg-cm, in-lb)	1.1 - 1.6 (11 - 16, 9.5 - 13.9)
Total preload N-m (kg-cm, in-lb)	1.2 - 2.2 (12 - 22, 10 - 19)
Side bearing adjusting method	Shim
Backlash	
Drive pinion to ring gear mm (in)	0.13 - 0.18 (0.0051 - 0.0071)
Side gear to pinion mate gear (Clearance between side gear to differential case) mm (in)	0.10 - 0.20 (0.0039 - 0.0079)
Ring gear runout limit mm (in)	0.08 (0.0031)

Side bearing adjusting shim (H190A)

Thickness mm (in)	Part No.
0.05 (0.0020)	38453-61200
0.07 (0.0028)	38454-61200
0.10 (0.0039)	38455-61200
0.20 (0.0079)	38456-61200
0.50 (0.0197)	38457-61200

Drive pinion adjusting washer (H190A)

Thickness mm (in)	Part No.
2.58 (0.1016)	38154-P6000
2.61 (0.1028)	38154-P6001
2.64 (0.1039)	38154-P6002
2.67 (0.1051)	38154-P6003
2.70 (0.1063)	38154-P6004
2.73 (0.1075)	38154-P6005
2.76 (0.1087)	38154-P6006
2.79 (0.1098)	38154-P6007
2.82 (0.1110)	38154-P6008
2.85 (0.1122)	38154-P6009
2.88 (0.1134)	38154-P6010
2.91 (0.1146)	38154-P6011
2.94 (0.1157)	38154-P6012
2.97 (0.1169)	38154-P6013
3.00 (0.1181)	38154-P6014
3.03 (0.1193)	38154-P6015
3.06 (0.1205)	38154-P6016
3.09 (0.1217)	38154-P6017
3.12 (0.1228)	38154-P6018
3.15 (0.1240)	38154-P6019
3.18 (0.1252)	38154-P6020

Side gear thrust washer (H190A)

Thickness mm (in)	Part No.
0.775 (0.0305)	38424-E3000
0.825 (0.0325)	38424-E3001
0.875 (0.0344)	38424-E3002
0.925 (0.0364)	38424-E3003

SERVICE DATA (C200)

Final drive model	C200
Drive pinion bearing preload adjusting method	Collapsible spacer
Drive pinion preload (With front oil seal) N-m (kg-cm, in-lb)	1.1 - 1.7 (11 - 17, 9.5 - 14.8)
Total preload N-m (kg-cm, in-lb)	1.2 - 2.3 (12 - 23, 10 - 20)
Side bearing adjusting method	Shim
Backlash	
Drive pinion to ring gear mm (in)	0.13 - 0.18 (0.0051 - 0.0071)
Side gear to pinion mate gear (Clearance between side gear to differential case) mm (in)	0.10 - 0.20 (0.0039 - 0.0079)
Ring gear runout limit mm (in)	0.05 (0.0020)

Side bearing adjusting shim (C200)

Thickness mm (in)	Part No.
2.00 (0.0787)	38453-N3100
2.05 (0.0807)	38453-N3101
2.10 (0.0827)	38453-N3102
2.15 (0.0846)	38453-N3103
2.20 (0.0866)	38453-N3104
2.25 (0.0886)	38453-N3105
2.30 (0.0906)	38453-N3106
2.35 (0.0925)	38453-N3107
2.40 (0.0945)	38453-N3108
2.45 (0.0965)	38453-N3109
2.50 (0.0984)	38953-N3110
2.55 (0.1004)	38453-N3111
2.60 (0.1024)	38453-N3112

SERVICE DATA AND SPECIFICATIONS (S.D.S.)

Differential Carrier (Cont'd)

Drive pinion adjusting washer (C200)

Thickness mm (in)	Part No.
3.09 (0.1217)	38154-P6017
3.12 (0.1228)	38154-P6018
3.15 (0.1240)	38154-P6019
3.18 (0.1252)	38154-P6020
3.21 (0.1264)	38154-P6021
3.24 (0.1276)	38154-P6022
3.27 (0.1287)	38154-P6023
3.30 (0.1299)	38154-P6024
3.33 (0.1311)	38154-P6025
3.36 (0.1323)	38154-P6026
3.39 (0.1335)	38154-P6027
3.42 (0.1346)	38154-P6028
3.45 (0.1358)	38154-P6029
3.48 (0.1370)	38154-P6030
3.51 (0.1382)	38154-P6031
3.54 (0.1394)	38154-P6032
3.57 (0.1406)	38154-P6033
3.60 (0.1417)	38154-P6034
3.63 (0.1429)	38154-P6035
3.66 (0.1441)	38154-P6036

Side gear thrust washer (C200) 2-pinion type differential case

Thickness mm (in)	Part No.
0.775 (0.0305)	38424-N3100
0.825 (0.0325)	38424-N3101
0.875 (0.0344)	38424-N3102

4-pinion type differential case

Thickness mm (in)	Part No.
0.775 (0.0305)	38424-E3000
0.825 (0.0325)	38424-E3001
0.875 (0.0344)	38424-E3002
0.925 (0.0364)	38424-E3003

SERVICE DATA (H233B)

Model		H233B
Drive pinion bearing adjusting method		Pinion bearing adjusting washer
Drive pinion preload (With front oil seal) N·m (kg-cm, in-lb)		0.5 - 1.0 (5 - 10, 4.3 - 8.7)
Side bearing adjusting method		Side adjuster
Backlash	Drive pinion to ring gear mm (in)	0.15 - 0.20 (0.0059 - 0.0079)
	Side gear to pinion mate gear (Clearance between side gear to differential case) mm (in)	0.10 - 0.20 (0.0039 - 0.0079)
Ring gear runout limit mm (in)		0.08 (0.0031)
Total preload N·m (kg-cm, in-lb)		1.0 - 2.0 (10 - 20, 8.7 - 17.4)

Model		H233B
Allowable warpage Friction disc, plate mm (in)		0.05 - 0.15 (0.0020 - 0.0059)
Wear limit Friction disc, plate and spring disc, plate mm (in)		0.1 (0.004) or less
Differential torque N·m (kg-m, ft-lb)		177 - 216 (18 - 22, 130 - 159)

DISCS AND PLATES

(For limited slip differential of H233B)

Unit: mm (in)

Part name	Thickness	Part number
		H233B
Friction plate	1.48 - 1.52 (0.0583 - 0.0598)	38432-C6000
Friction disc	1.48 - 1.52 (0.0583 - 0.0598)	38433-C6000 (Standard type)
	1.58 - 1.62 (0.0622 - 0.0638)	38433-C6001 (Adjusting type)
Spring disc	1.48 - 1.52 (0.0583 - 0.0598)	38436-C6000
Spring plate	1.48 - 1.52 (0.0583 - 0.0598)	38435-C6010

SERVICE DATA AND SPECIFICATIONS (S.D.S.)

Differential Carrier (Cont'd)

Drive pinion bearing adjusting shim (H233B)

Thickness mm (in)	Part No.
0.40 (0.0157)	24127-4301P
0.45 (0.0177)	24127-4302P
0.50 (0.0197)	24127-4303P
0.55 (0.0217)	24127-4304P
0.60 (0.0236)	24127-4305P
0.65 (0.0256)	24127-4306P
0.70 (0.0276)	24127-4307P
0.75 (0.0295)	24127-4308P

Side gear thrust washer

Thickness mm (in)	Part No.
1.75 (0.0689)	38424-T5000
1.80 (0.0709)	38424-T5001
1.85 (0.0728)	38424-T5002

Drive pinion adjusting washer (H233B)

Thickness mm (in)	Part No.
2.58 (0.1016)	38154-P6000
2.61 (0.1028)	38154-P6001
2.64 (0.1039)	38154-P6002
2.67 (0.1051)	38154-P6003
2.70 (0.1063)	38154-P6004
2.73 (0.1075)	38154-P6005
2.76 (0.1087)	38154-P6006
2.79 (0.1098)	38154-P6007
2.82 (0.1110)	38154-P6008
2.85 (0.1122)	38154-P6009
2.88 (0.1134)	38154-P6010
2.91 (0.1146)	38154-P6011
2.94 (0.1157)	38154-P6012
2.97 (0.1169)	38154-P6013
3.00 (0.1181)	38154-P6014
3.03 (0.1193)	38154-P6015
3.06 (0.1205)	38154-P6016
3.09 (0.1217)	38154-P6017
3.12 (0.1228)	38154-P6018
3.15 (0.1240)	38154-P6019
3.18 (0.1252)	38154-P6020
3.21 (0.1264)	38154-P6021
3.24 (0.1276)	38154-P6022
3.27 (0.1287)	38154-P6023
3.30 (0.1299)	38154-P6024
3.33 (0.1311)	38154-P6025
3.36 (0.1323)	38154-P6026
3.39 (0.1335)	38154-P6027
3.42 (0.1346)	38154-P6028
3.45 (0.1358)	38154-P6029
3.48 (0.1370)	38154-P6030
3.51 (0.1382)	38154-P6031
3.54 (0.1394)	38154-P6032
3.57 (0.1406)	38154-P6033
3.60 (0.1417)	38154-P6034
3.63 (0.1429)	38154-P6035
3.66 (0.1441)	38154-P6036

SERVICE DATA AND SPECIFICATIONS (S.D.S.)

Differential Carrier (Cont'd)

TIGHTENING TORQUE (R180A)

Unit	N·m	kg·m	ft·lb
Final drive installation			
Rear cover to mounting insulator	68 - 87	6.9 - 8.9	50 - 64
Mounting insulator to body	68 - 87	6.9 - 8.9	50 - 64
Differential carrier to suspension member	68 - 87	6.9 - 8.9	50 - 64
Companion flange to propeller shaft	39 - 44	4.0 - 4.5	29 - 33
Companion flange to drive shaft	34 - 44	3.5 - 4.5	25 - 33
Final drive assembly			
Drive pinion nut	167 - 196	17 - 20	123 - 145
Ring gear bolt	93 - 113	9.5 - 11.5	69 - 83
Differential case couple bolt (4-pinion)	64 - 78	6.5 - 8.0	47 - 58
Side retainer bolt	9 - 12	0.9 - 1.2	6.5 - 8.7
Rear cover fixing bolt	39 - 49	4 - 5	29 - 36
Filler and drain plugs	39 - 59	4 - 6	29 - 43

TIGHTENING TORQUE (R200A)

Unit	N·m	kg·m	ft·lb
Final drive installation			
Rear cover to mounting insulator	68 - 87	6.9 - 8.9	50 - 64
Mounting insulator to body	68 - 87	6.9 - 8.9	50 - 64
Differential carrier to suspension member	68 - 87	6.9 - 8.9	50 - 64
Companion flange to propeller shaft	39 - 44	4.0 - 4.5	29 - 33
Companion flange to drive shaft	34 - 44	3.5 - 4.5	25 - 33
Final drive assembly			
Drive pinion nut	186 - 294	19 - 30	137 - 217
Ring gear bolt [using Locktite (stud lock) or equivalent]	132 - 152	13.5 - 15.5	98 - 112
Side bearing cap bolt	88 - 98	9.0 - 10.0	65 - 72
Rear cover fixing bolt	39 - 49	4 - 5	29 - 36
Filler and drain plugs	39 - 59	4 - 6	29 - 43

TIGHTENING TORQUE (H190A)

Unit	N·m	kg·m	ft·lb
Final drive installation			
Differential carrier to rear axle case fixing bolt	17 - 25	1.7 - 2.5	12 - 18
Companion flange to propeller shaft	39 - 44	4.0 - 4.5	29 - 33
Final drive assembly			
Drive pinion nut	127 - 294	13 - 30	94 - 217
Ring gear bolt			
M12 bolt	132 - 152	13.5 - 15.5	98 - 112
Side bearing cap bolt	49 - 59	5 - 6	36 - 43
Drain and filler plugs	59 - 98	6 - 10	43 - 72

TIGHTENING TORQUE (C200)

Unit	N·m	kg·m	ft·lb
Final drive installation			
Companion flange to propeller shaft			
2WD	39 - 44	4.0 - 4.5	29 - 33
4WD	78 - 88	8 - 9	58 - 65
Final drive assembly			
Drive pinion nut	127 - 294	13 - 30	94 - 217
Ring gear bolt			
M12 bolt	132 - 152	13.5 - 15.5	98 - 112
Side bearing cap bolt	88 - 98	9 - 10	65 - 72
Rear cover fixing bolt			
Bolt with spring washer type	11 - 14	1.1 - 1.4	8 - 10
Filler plug	39 - 59	4 - 6	29 - 43
Drain plug	59 - 98	6 - 10	43 - 72

TIGHTENING TORQUE (H233B)

Unit	N·m	kg·m	ft·lb
Final drive installation			
Differential carrier to rear axle case fixing bolt	27 - 36	2.8 - 3.7	20 - 27
Companion flange to propeller shaft	78 - 88	8 - 9	58 - 65
Final drive assembly			
Drive pinion nut	196 - 245	20 - 25	145 - 181
Ring gear bolt	132 - 152	13.5 - 15.5	98 - 112
Side bearing cap bolt	93 - 103	9.5 - 10.5	69 - 76
Drain and filler plugs	59 - 98	6 - 10	43 - 72

FRONT AXLE & FRONT SUSPENSION

SECTION **FA**

CONTENTS

PRECAUTIONS	FA- 2
PREPARATION	FA- 3
FRONT AXLE AND FRONT SUSPENSION	FA- 4
CHECK AND ADJUSTMENT – On-vehicle	FA- 6
FRONT AXLE	FA-15
FRONT AXLE (4WD) – Manual-lock Free-running Hub	FA-17
FRONT AXLE (4WD) – Auto-lock Free-running Hub	FA-18
FRONT AXLE – Wheel Hub and Rotor Disc	FA-22
FRONT AXLE – Knuckle Spindle	FA-24
FRONT AXLE (4WD) – Drive Shaft	FA-27
FRONT SUSPENSION	FA-34
ADJUSTABLE SHOCK ABSORBER (Including wiring diagram)	FA-47
SERVICE DATA AND SPECIFICATIONS (S.D.S.)	FA-51

When you read wiring diagrams:

- Read GI section, "HOW TO READ WIRING DIAGRAMS".
- See EL section, "POWER SUPPLY ROUTING" for power distribution circuit.

FA

PRECAUTIONS

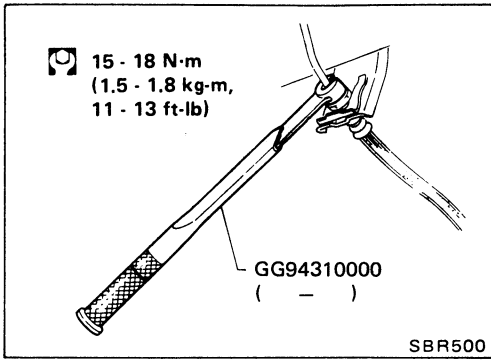

- (1) When installing each rubber part, final tightening must be carried out under unladen condition* with tires on ground.
 - * Fuel, radiator coolant and engine oil full. Spare tire, jack, hand tools, and mats in designated positions.
- (2) When removing each suspension part, check wheel alignment and adjust if necessary.
- (3) Use Tool when removing or installing brake tubes.

PREPARATION

SPECIAL SERVICE TOOLS

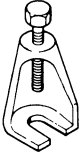
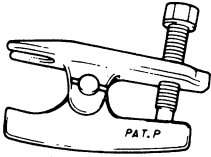
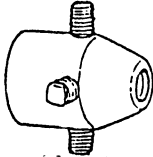
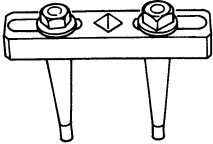
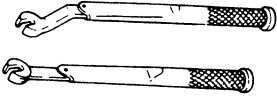
Tool number (Kent-Moore No.) Tool name	Description	Unit application		
		2WD	4WD	
ST29020001 (J24319-01) Gear arm puller		Removing ball joint for knuckle spindle	X	X
HT72520000 (J25730-A) Ball joint remover		Removing tie-rod outer end	X	X
KV401021S0 (-) Bearing race drift		Installing wheel bearing outer race	X	-
KV40105400 (J36001) Wheel bearing lock nut wrench		Removing or installing wheel bearing lock nut	-	X
GG94310000 (-) Flare nut torque wrench		Removing and installing brake piping	X	X

Wheel bearing

- Refer to PRELOAD ADJUSTMENT (2WD) of Front Wheel Bearing in CHECK AND ADJUSTMENT – On-vehicle.

Wheel alignment

- Refer to Front Wheel Alignment of CHECK AND ADJUSTMENT – On-vehicle.

FA-4

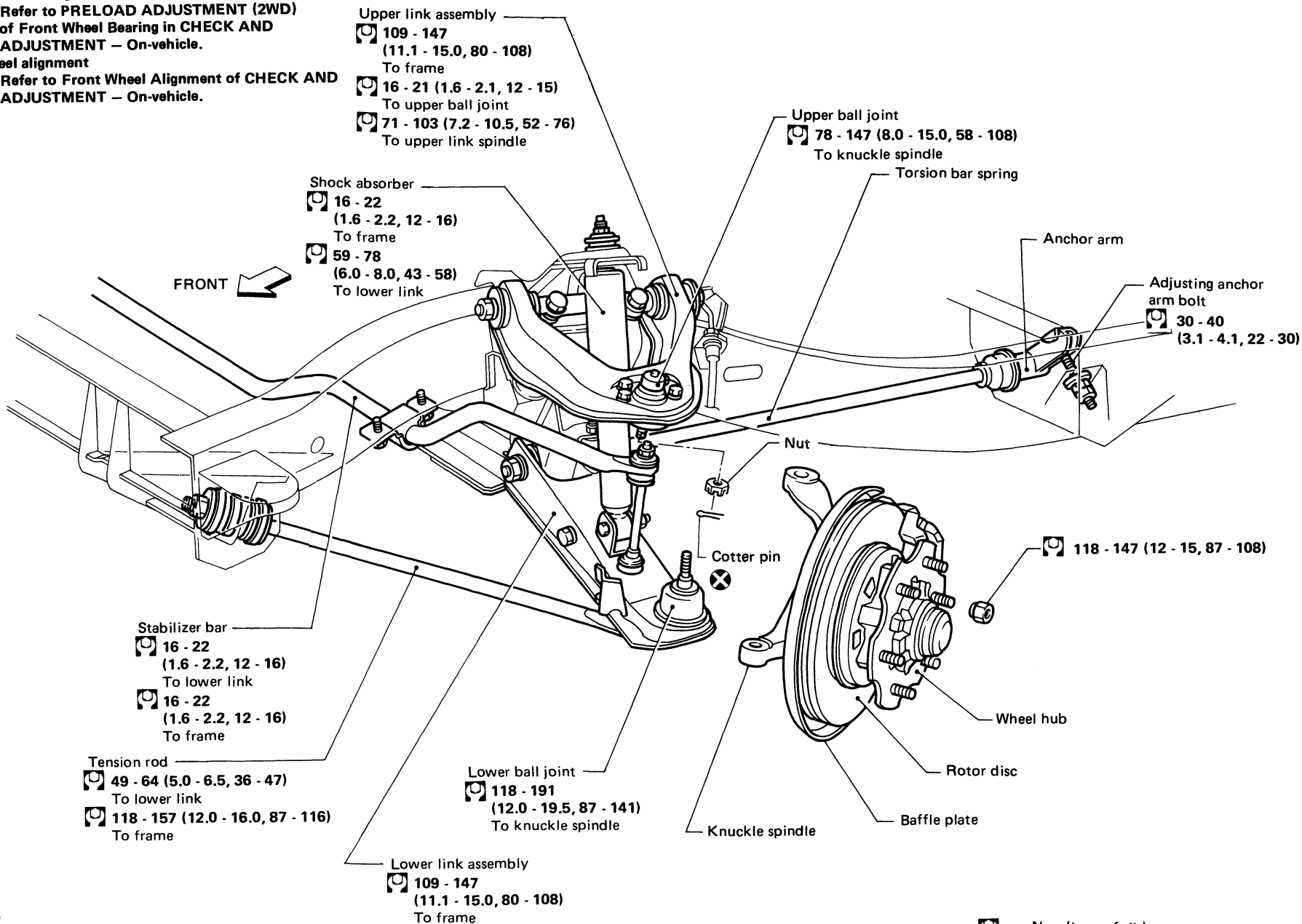

: N·m (kg·m, ft·lb)

Wheel bearing

- Refer to PRELOAD ADJUSTMENT (4WD) of Front Wheel Bearing in CHECK AND ADJUSTMENT – On-vehicle.

Wheel alignment

- Refer to Front Wheel Alignment of CHECK AND ADJUSTMENT – On-vehicle.

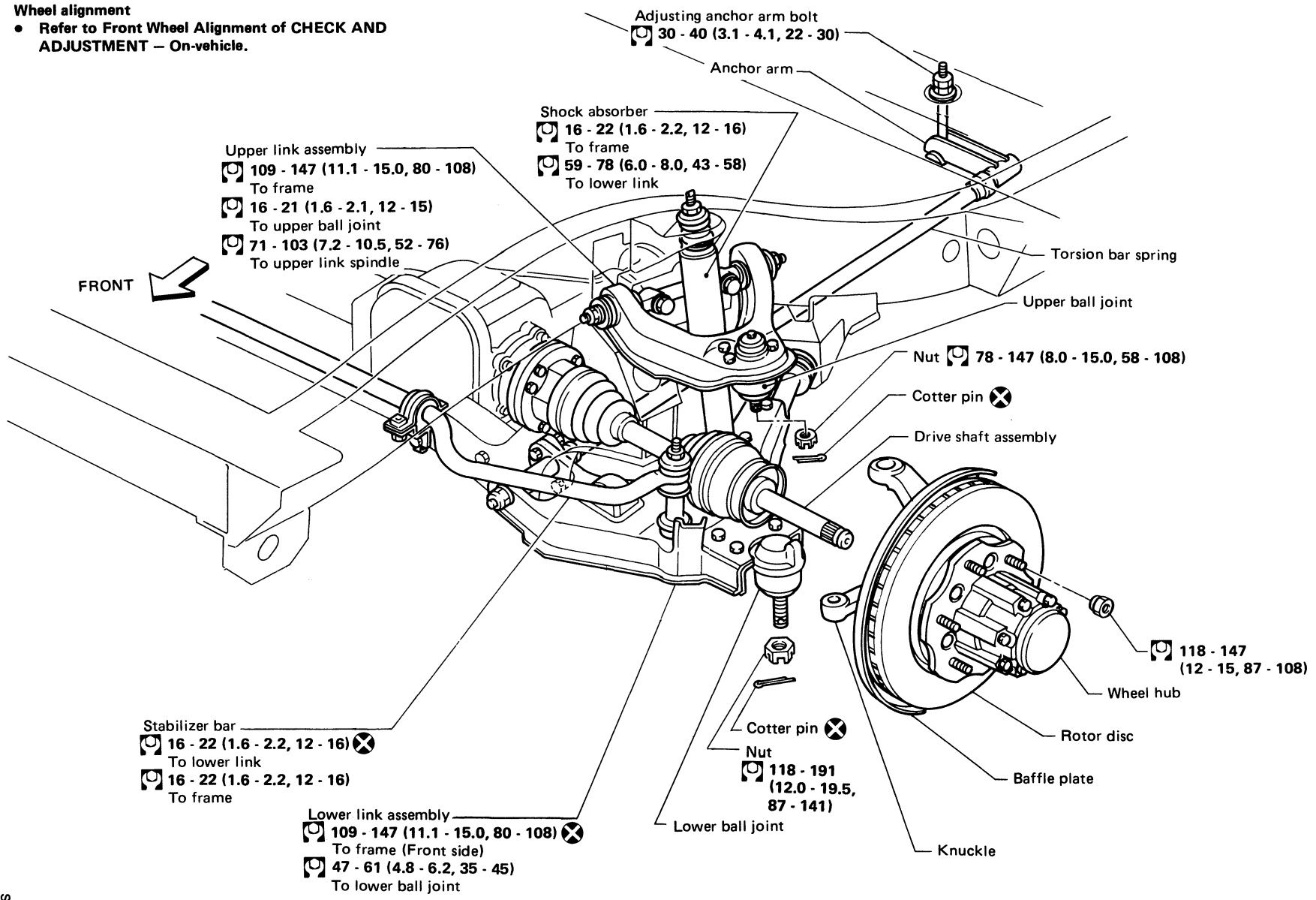

FRONT

FA-5

SFA824

: N·m (kg·m, ft·lb)

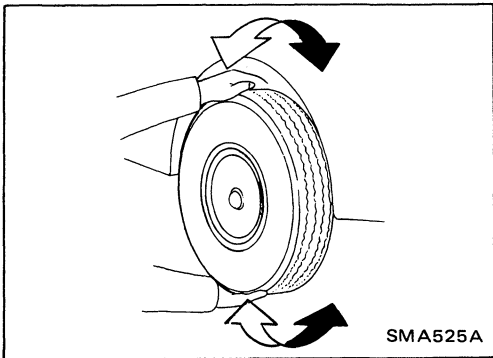

Front Axle and Front Suspension Parts

- Check front axle and front suspension parts for looseness, cracks, wear or other damage.
 - (1) Shake each front wheel.
 - (2) Make sure that cotter pin is inserted.
 - (3) Retighten all nuts and bolts to the specified torque.

Tightening torque: Refer to S.D.S.

- (4) Check front axle and front suspension parts for wear, cracks or other damage.

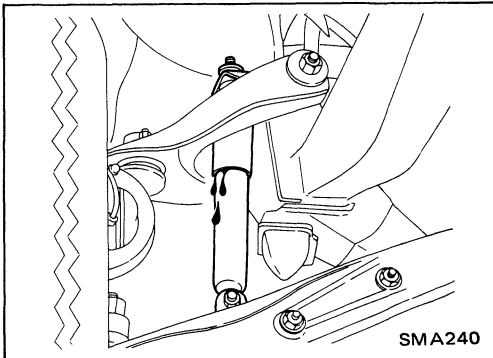

- Check shock absorber for oil leakage or other damage.

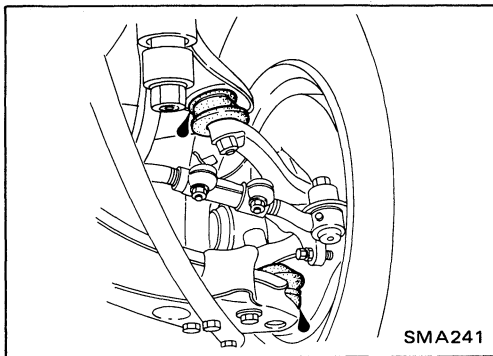

- Check suspension ball joint for grease leakage and ball joint dust cover for cracks or other damage.

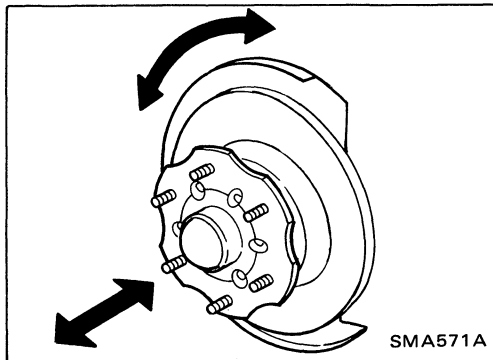

Front Wheel Bearing

- Check that wheel bearings operate smoothly.
- Check axial end play.

Axial end play: 0 mm (0 in)
- Adjust wheel bearing preload if there is any axial end play or wheel bearing does not turn smoothly.

PRELOAD ADJUSTMENT (2WD)

Adjust wheel bearing preload after wheel bearing has been replaced or front axle has been reassembled.

Adjust wheel bearing preload as follows.

1. Before adjustment, thoroughly clean all parts to prevent dirt entry.

Front Wheel Bearing (Cont'd)

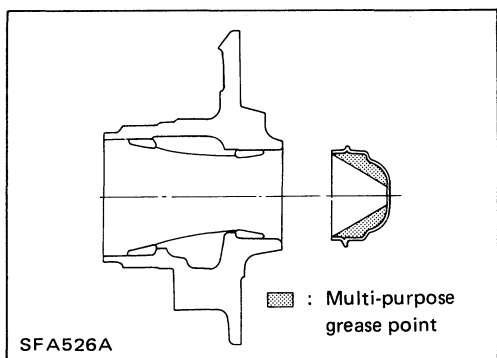

2. Apply multi-purpose grease sparingly to the following parts:

- Rubbing surface of spindle
- Contact surface between lock washer and outer wheel bearing
- Hub cap (as shown at left)
- Grease seal lip

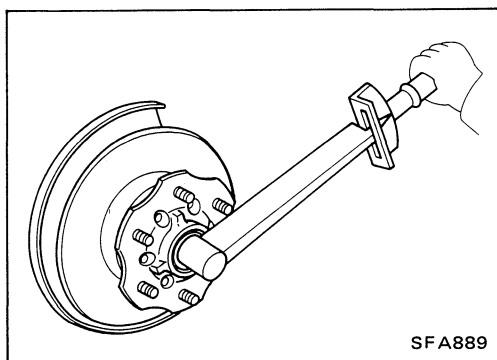

3. Tighten wheel bearing lock nut to the specified torque.

 : 34 - 39 N·m (3.5 - 4.0 kg·m, 25 - 29 ft·lb)

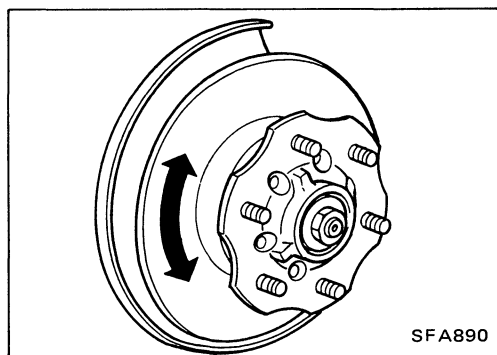

4. Turn wheel hub several times in both directions to seat wheel bearing correctly.

5. Again tighten wheel bearing lock nut to the specified torque.

 : 34 - 39 N·m (3.5 - 4.0 kg·m, 25 - 29 ft·lb)

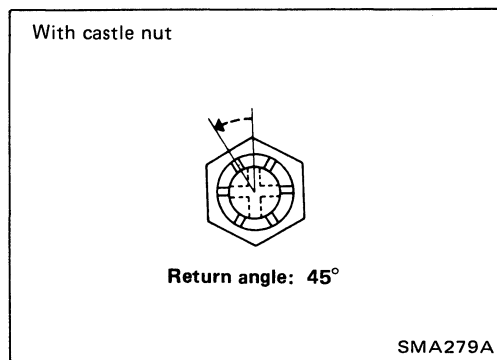

6. Turn back wheel bearing lock nut 45 degrees.

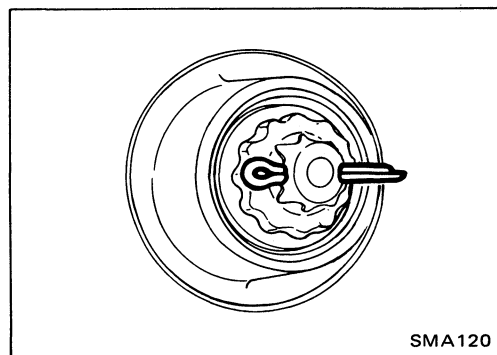

7. Fit adjusting cap and new cotter pin. Align cotter pin slot by loosening nut 15 degrees or less.

CHECK AND ADJUSTMENT — On-vehicle

Front Wheel Bearing (Cont'd)

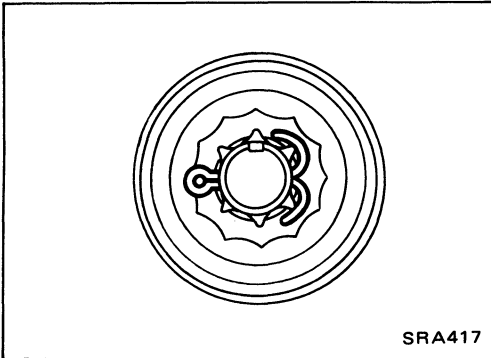
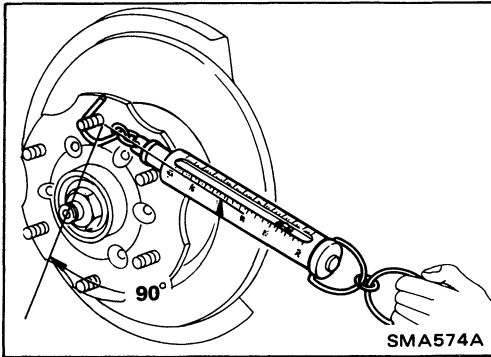

8. Measure wheel bearing preload and axial end play.

Axial end play: 0 mm (0 in)

Wheel bearing preload

(As measured at wheel hub bolt):

[New grease seal]

9.8 - 28.4 N (1.0 - 2.9 kg, 2.2 - 6.4 lb)

[Used grease seal]

9.8 - 23.5 N (1.0 - 2.4 kg, 2.2 - 5.3 lb)

Repeat above procedures until correct bearing preload is obtained.

9. Spread cotter pin.

10. Install hub cap.

PRELOAD ADJUSTMENT (4WD)

Adjust wheel bearing preload after wheel bearing has been replaced or front axle has been reassembled.

Adjust wheel bearing preload as follows:

1. Before adjustment, thoroughly clean all parts to prevent dirt entry.

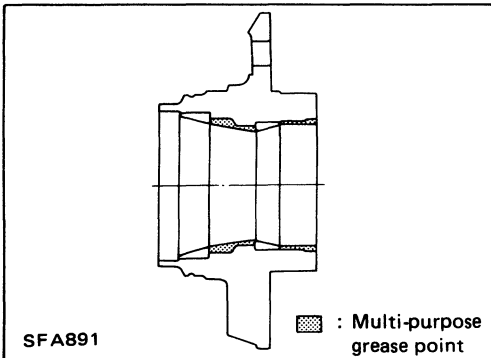

2. Apply multi-purpose grease sparingly to the following parts:

- Threaded portion of spindle
- Contact surface between wheel bearing washer and outer wheel bearing
- Grease seal lip
- Wheel hub (as shown at left)

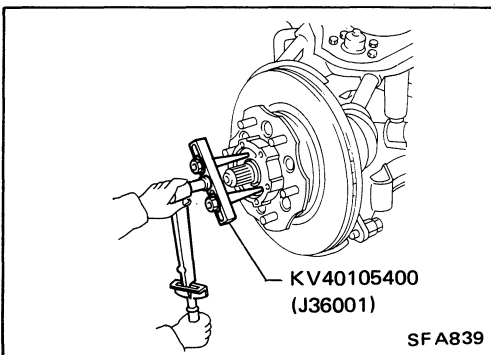

3. Tighten wheel bearing lock nut with Tool.

 : **78 - 98 N·m**

(8 - 10 kg-m, 58 - 72 ft-lb)

4. Turn wheel hub several times in both directions.

5. Loosen wheel bearing lock nut so that torque becomes 0 N·m (0 kg-m, 0 ft-lb).

6. Retighten wheel bearing lock nut with Tool.

 : **0.5 - 1.5 N·m**

(0.05 - 0.15 kg-m, 0.4 - 1.1 ft-lb)

Front Wheel Bearing (Cont'd)

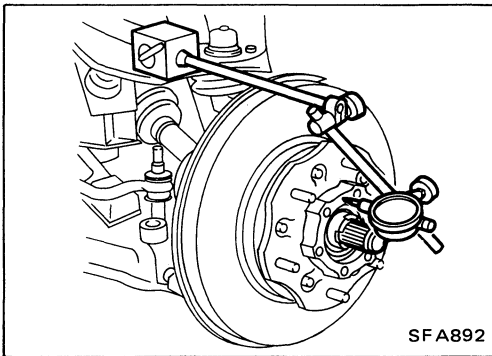

7. Turn wheel hub several times in both directions.
8. Retighten wheel bearing lock nut with Tool.
☞ : 0.5 - 1.5 N·m
(0.05 - 0.15 kg·m, 0.4 - 1.1 ft·lb)
9. Measure wheel bearing axial end play.
Axial end play: 0 mm (0 in)

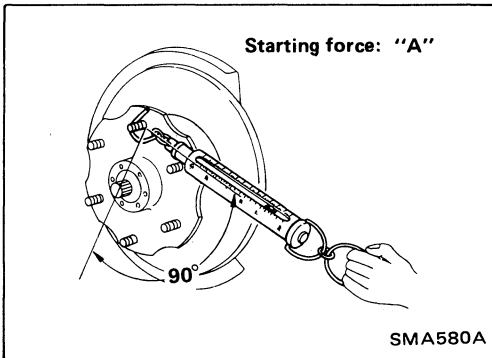

10. Measure starting force "A" at wheel hub bolt.

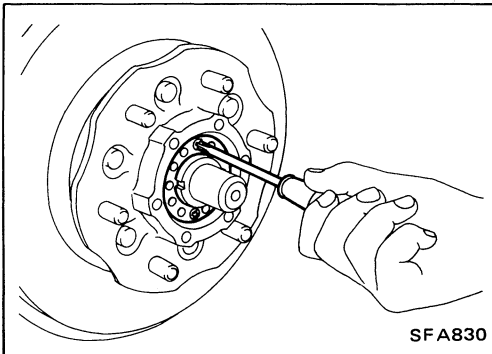

11. Install lock washer by tightening the lock nut within 15 to 30 degrees.
12. Turn wheel hub several times in both directions to seat wheel bearing correctly.
13. Measure starting force "B" at wheel hub bolt. Refer to procedure 10.

14. Wheel bearing preload "C" can be calculated as shown below.

$$C = B - A$$

Wheel bearing preload "C":

7.06 - 20.99 N

(0.72 - 2.14 kg, 1.59 - 4.72 lb)

15. Repeat above procedures until correct axial end play and wheel bearing preload are obtained.
16. Install free-running hub and brake pads.

Front Wheel Alignment

Before checking front wheel alignment, be sure to make a preliminary inspection.

PRELIMINARY INSPECTION

1. Check the tires for wear and proper inflation.

CHECK AND ADJUSTMENT — On-vehicle

Front Wheel Alignment (Cont'd)

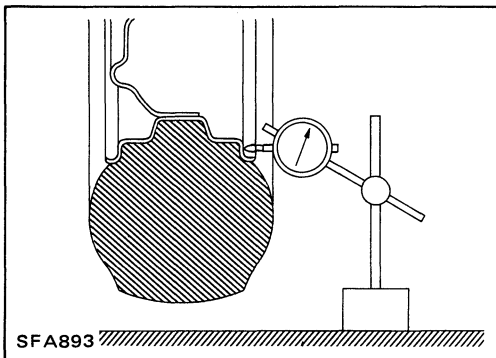

2. Check the wheel runout.

Lateral runout:

Refer to Wheel Inspection of section MA.

3. Check the front wheel bearings for looseness.
4. Check the front suspension for looseness.
5. Check the steering linkage for looseness.
6. Check that the front shock absorbers work properly by using the standard bounce test.

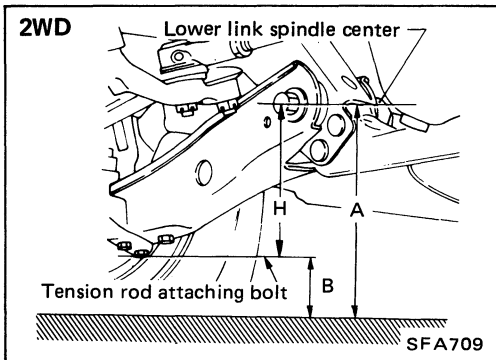

7. Measure vehicle height (Unladen): $H = A - B$ mm (in)

Refer to S.D.S.

(1) Exercise the front suspension by bouncing the front of the vehicle 4 or 5 times to ensure that the vehicle is in a neutral height attitude.

(2) Measure wheel alignment.

(Refer to **B** SERVICE CHECKING on S.D.S.)

(3) If wheel alignment is not as specified, adjust vehicle posture.

(Refer to **A** SERVICE SETTING on S.D.S.)

(4) Adjust wheel alignment.

(Refer to **B** SERVICE SETTING on S.D.S.)

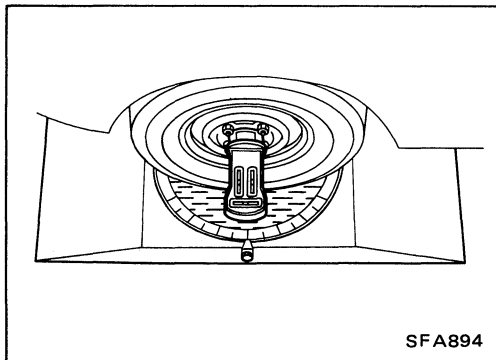
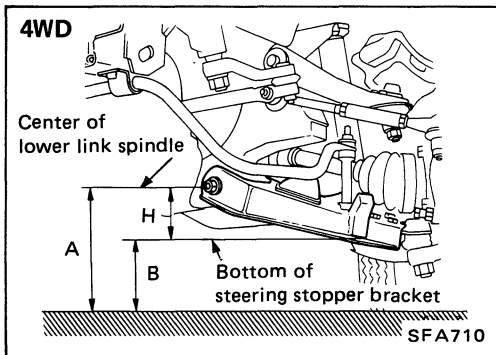

CAMBER, CASTER AND KINGPIN INCLINATION

Before checking camber, caster or kingpin inclination, move vehicle up and down on turning radius gauge to minimize friction. Ensure that vehicle is in correct posture.

- Measure camber, caster and kingpin inclination of both right and left wheels with a suitable alignment gauge and adjust in accordance with the following procedures.

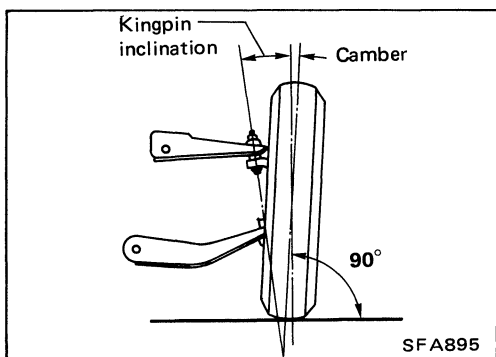

Camber (Unladen):

Refer to S.D.S.

Kingpin inclination (Unladen):

Refer to S.D.S.

Front Wheel Alignment (Cont'd)

Caster (Unladen):
Refer to S.D.S.

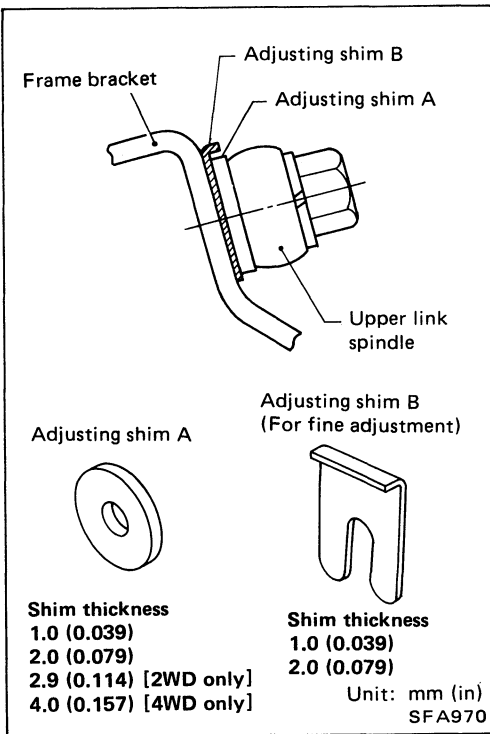
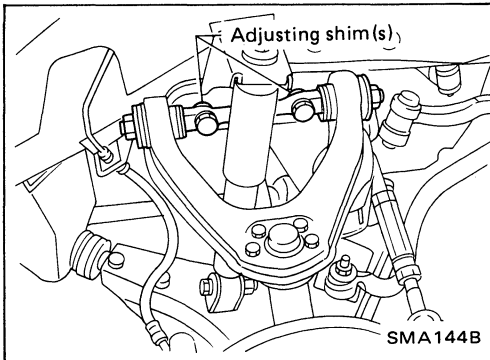
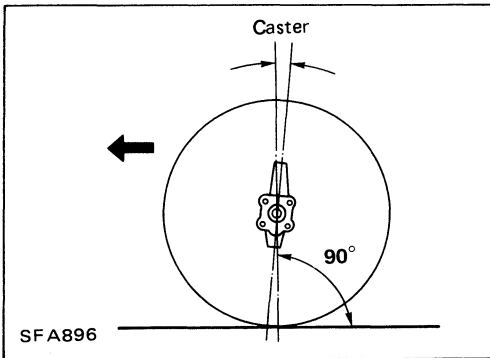

ADJUSTMENT

Both camber and caster angles are adjusted by increasing or decreasing the number of adjusting shims inserted between upper link spindle and frame.

Before removing or installing adjusting shim(s), be sure to place a jack under lower link.

Adjusting shim standard thickness:

2WD	2.9 mm (0.114 in)
4WD	4.0 mm (0.157 in)

- Do not use three or more shims at one place.
- When installing shim B, always face the pawl towards spindle and insert them from bracket side. Use only one shim in a place.
- Total thickness of shims must be within 8.0 mm (0.315 in).

Camber

To adjust camber, equalize thickness of front and rear shims by adding or removing shim(s).

Camber (Unladen):

Refer to S.D.S.

- When adding 1.0 mm (0.039 in) shim to each of the front and rear.

Camber increases:

2WD	12'
4WD	14'

Front Wheel Alignment (Cont'd)

Caster

To adjust caster, make a difference in thickness between front and rear shims.

Caster (Unladen):

Refer to S.D.S.

- When front shim(s) is 1.0 mm (0.039 in) thicker than rear one(s),

	2WD	4WD
Caster increases	19'	26'
Camber increases	6'	6'

- When rear shim(s) is 1.0 mm (0.039 in) thicker than front one(s),

	2WD	4WD
Caster decreases	19'	20'
Camber increases	6'	8'

- Difference of total thickness of the front and rear must be within 2.0 mm (0.079 in).
- When caster is adjusted, camber angle changes and camber needs to be measured again. If necessary, adjust camber.

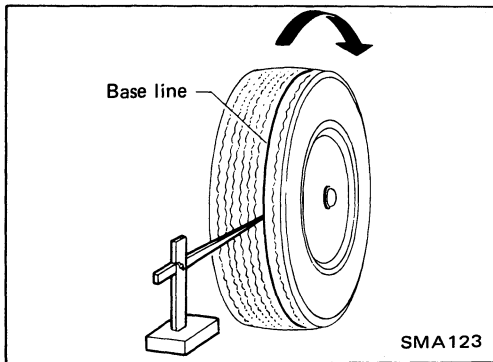

TOE-IN

1. Mark a base line across the tread.

After lowering front of vehicle, move it up and down to eliminate friction, and set steering wheel in straight ahead position.

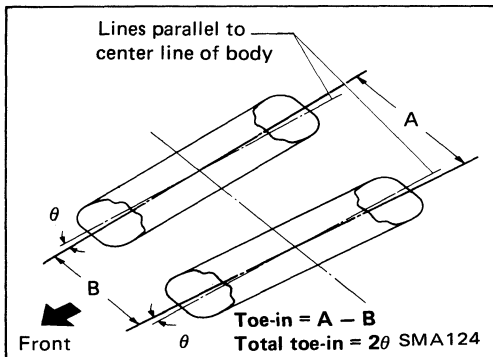

2. Measure toe-in.

Measure distance "A" and "B" at the same height as hub center.

Toe-in (Unladen):

Refer to S.D.S.

CHECK AND ADJUSTMENT — On-vehicle

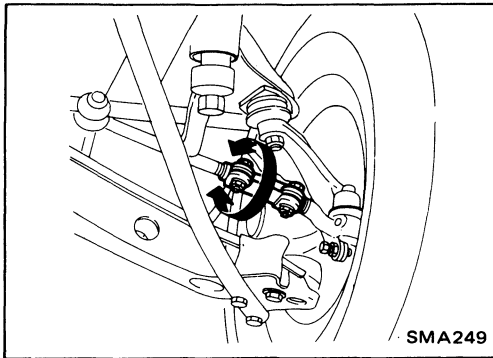

Front Wheel Alignment (Cont'd)

3. Adjust toe-in by varying the length of steering tie-rods.

- (1) Loosen clamp bolts or lock nuts.
- (2) Adjust toe-in by turning the left and right tie-rod tubes an equal amount.

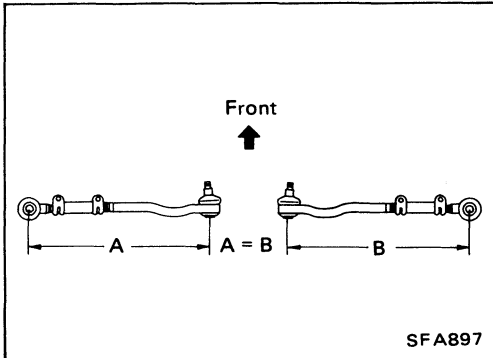

Make sure that the tie-rod bars are screwed into the tie-rod tube more than 35 mm (1.38 in).

Make sure that the tie-rods are the same length.

Standard length (A = B):

2WD 344 mm (13.54 in)

4WD 281 mm (11.06 in)

- (3) Tighten clamp bolts or lock nuts, then torque them.

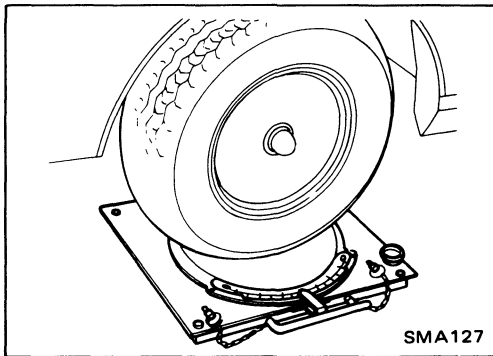

FRONT WHEEL TURNING ANGLE

1. Set wheels in straight ahead position and then move vehicle forward until front wheels rest on turning radius gauge properly.

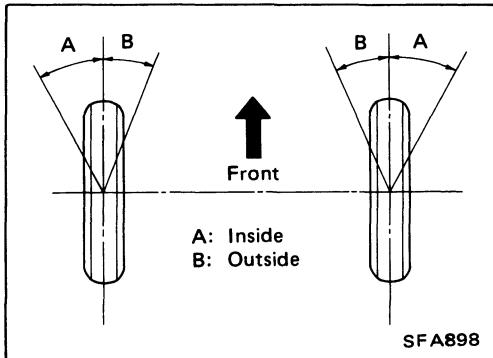

2. Rotate steering wheel all the way right and left; measure turning angle.

Wheel turning angle		2WD	4WD	
			31 x 10.5R15*	
Full turns	Inside wheel	36° - 38°	33° - 35°	27° - 29°
	Outside wheel	33° - 35°	31° - 33°	25° - 27°
Toe-out turn (at 20°)	Inside wheel	22°		
	Outside wheel	20°		

*: Tire size

Front Wheel Alignment (Cont'd)

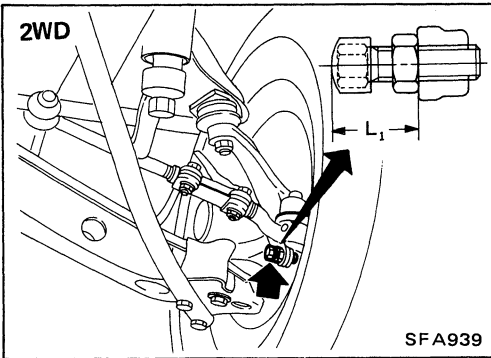

3. Adjust by stopper bolt if necessary.

[2WD]

Standard length " L_1 ": 20 mm (0.79 in)

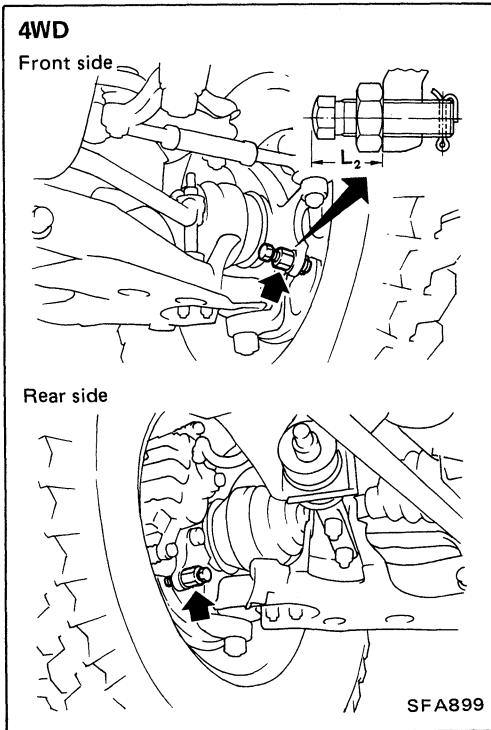

[4WD]

Standard length " L_2 ":

26.5 mm (1.043 in)

[Except tire size: 31x10.5R15]

37.5 mm (1.476 in)

[Tire size: 31x10.5R15]

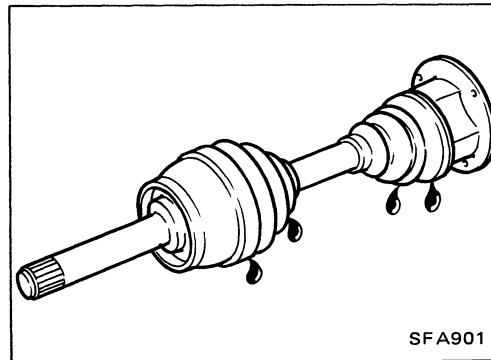

Drive Shaft

- Check for grease leakage or other damage.

FRONT AXLE

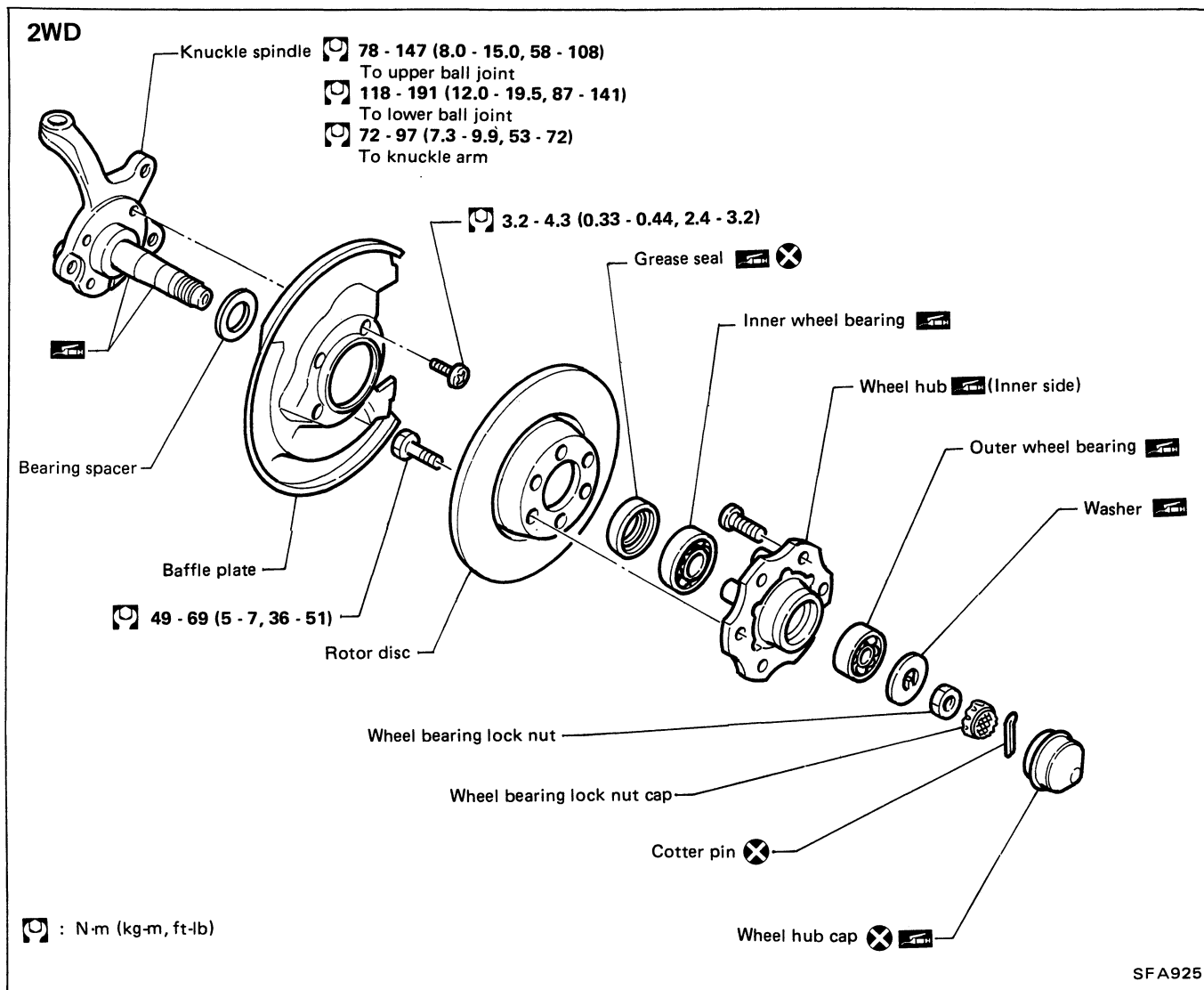

FRONT AXLE

4WD

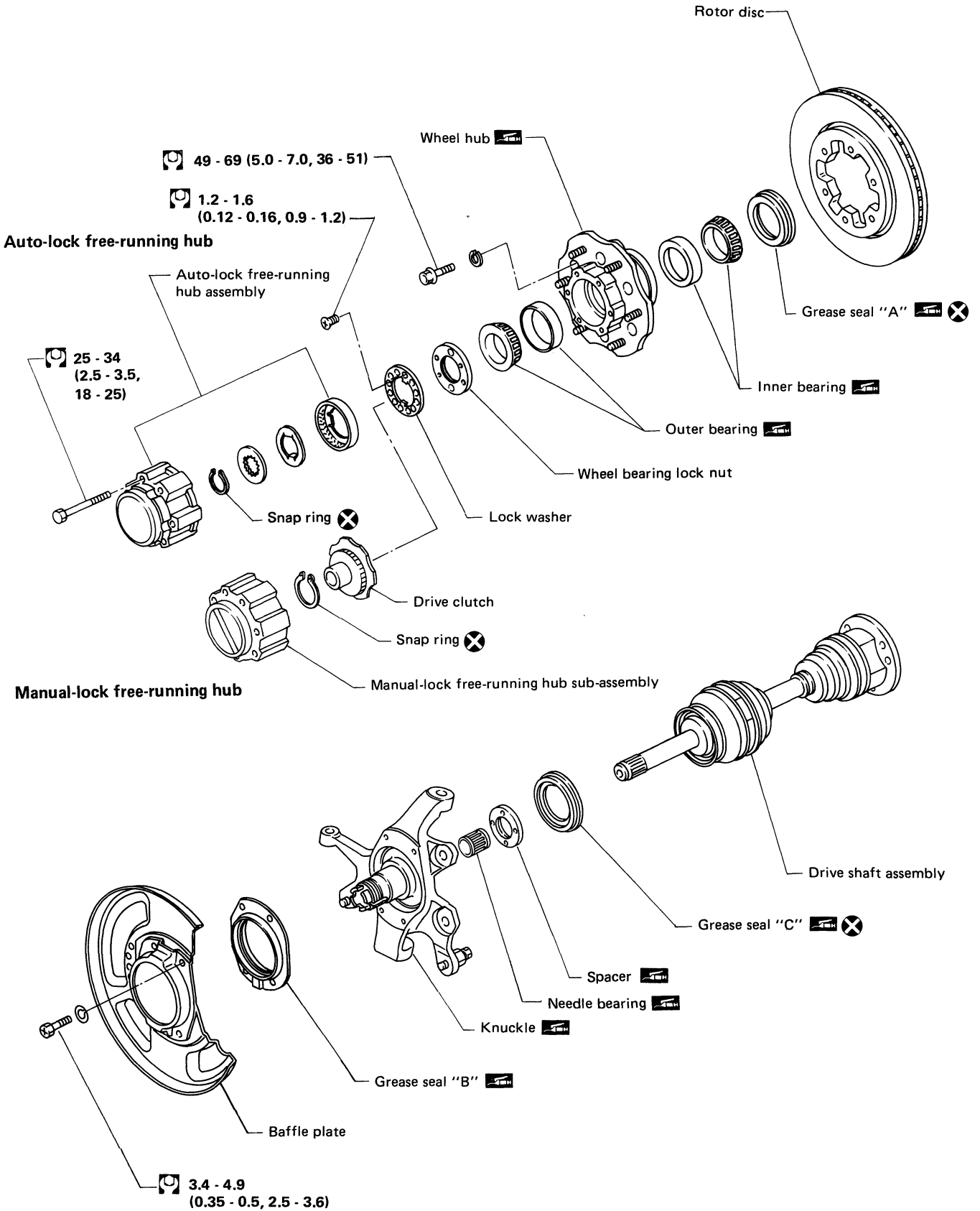

: N·m (kg-m, ft-lb)

SFA825

FRONT AXLE (4WD) — Manual-lock Free-running Hub

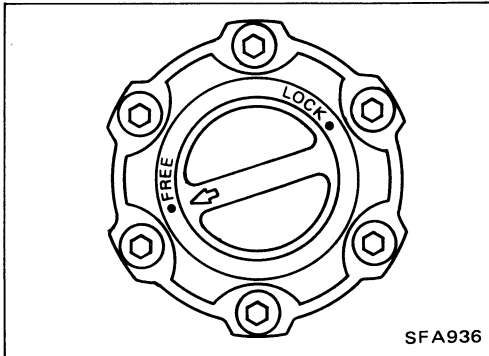
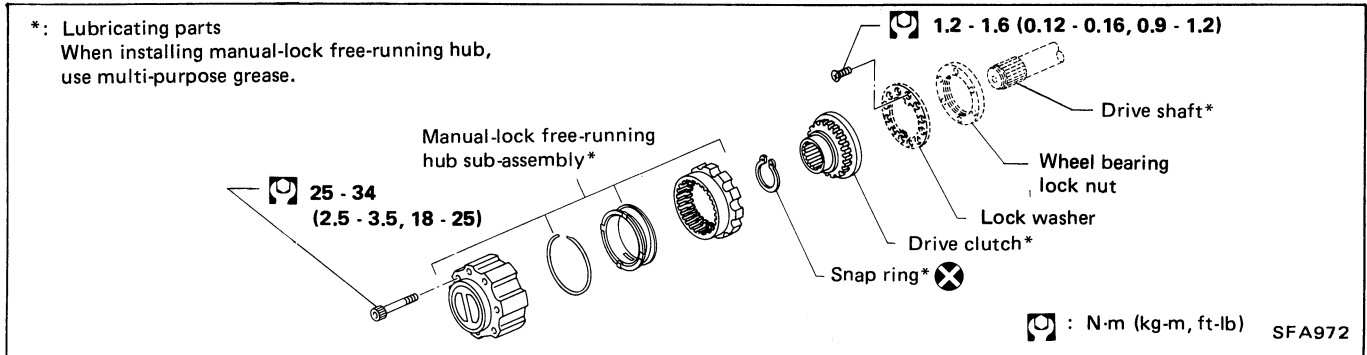

Removal and Installation

- Set knob of manual-lock free-running hub in position "Free".
- Remove manual-lock free-running hub with brake pedal depressed.

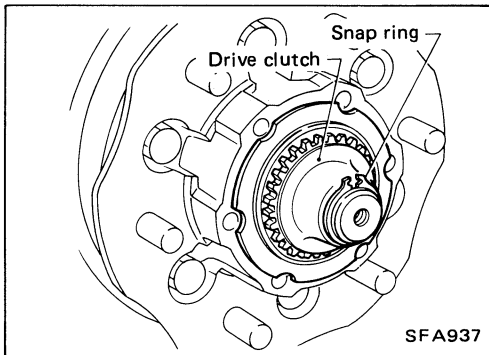

- Remove snap ring and then draw out drive clutch.

- When installing manual-lock free-running hub, make sure the position is in "Free".

Apply multi-purpose grease to the parts shown in the above illustration.

- Check operation of manual-lock free-running hub after installing it.

Inspection

- Check that knob moves smoothly and freely.
- Check that the clutch moves smoothly in the body.

FRONT AXLE (4WD) — Auto-lock Free-running Hub

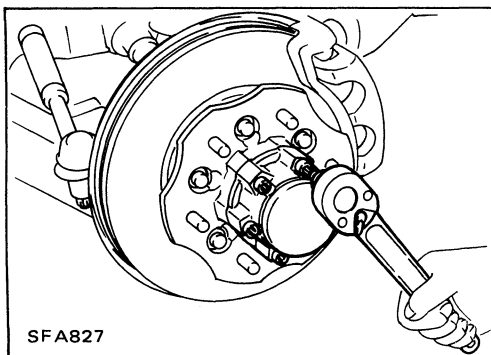
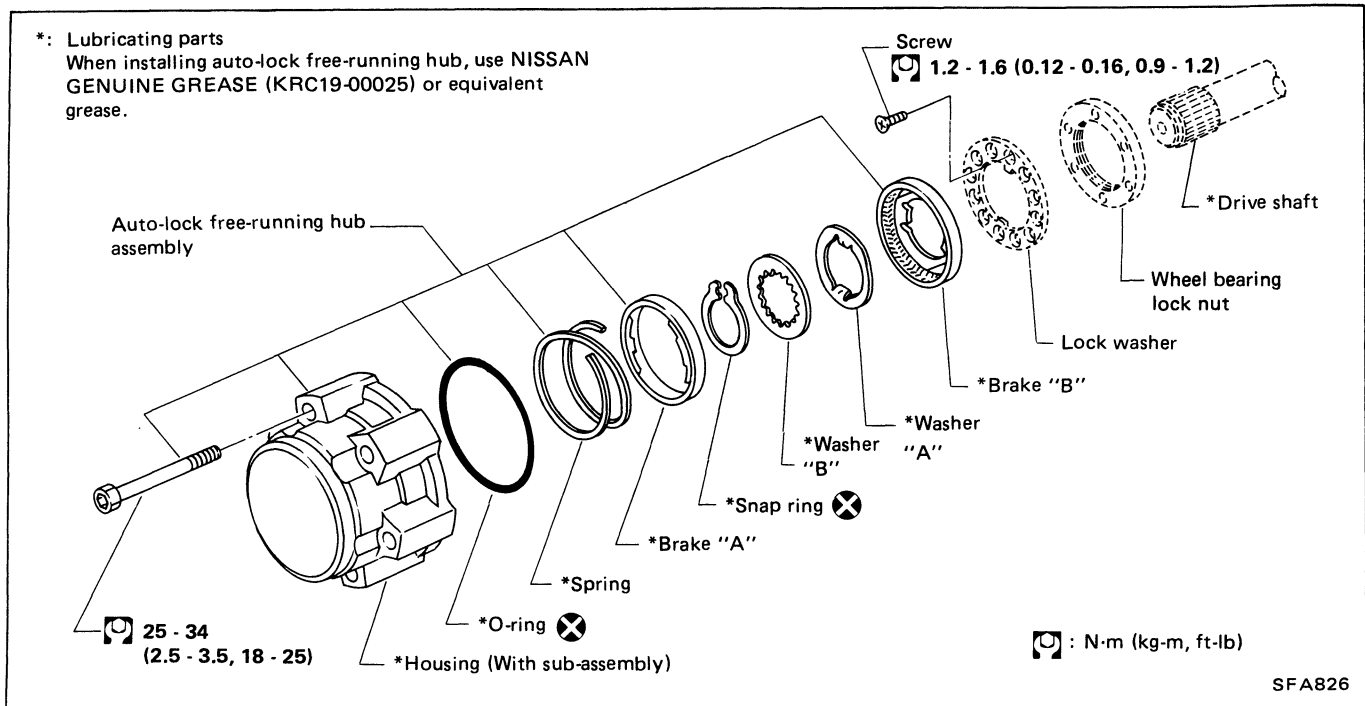

Removal and Installation

- Set auto-lock free-running hub in position "Free".
- Remove auto-lock free-running hub with brake pedal depressed.

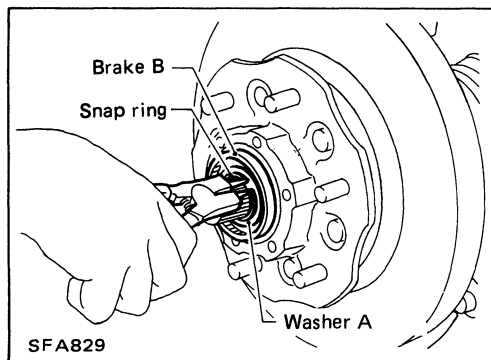

- Remove snap ring.
- Remove washer B, washer A and brake B.
- After installing auto-lock free-running hub, check operation it.

When installing it, apply recommended grease to the parts shown in the above illustration.

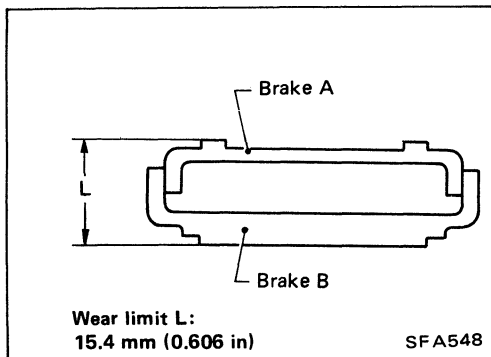

Inspection

Thoroughly clean parts with cleaning solvent and dry with compressed air.

Brake "A" and "B"

Measure the thickness "L" of brake "A" and "B".

If thickness is less than the specified limit, replace brake "A" and "B" as a set.

Trouble-shooting

Noise occurring in the auto hub under any of the conditions described below is not indicative of a problem. Noise can be eliminated by properly operating the transfer lever or the vehicle.

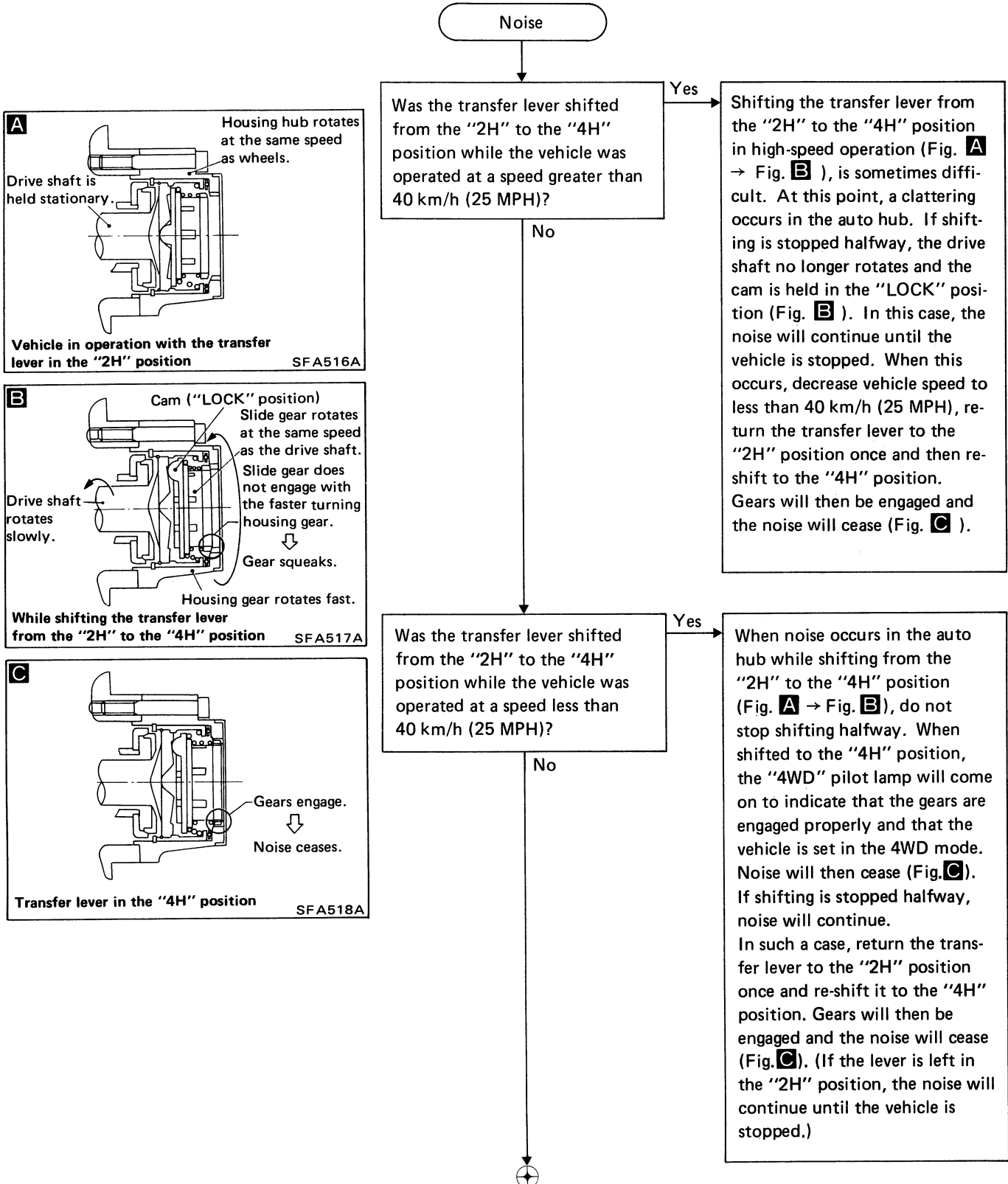

FRONT AXLE (4WD) — Auto-lock Free-running Hub

Trouble-shooting (Cont'd)

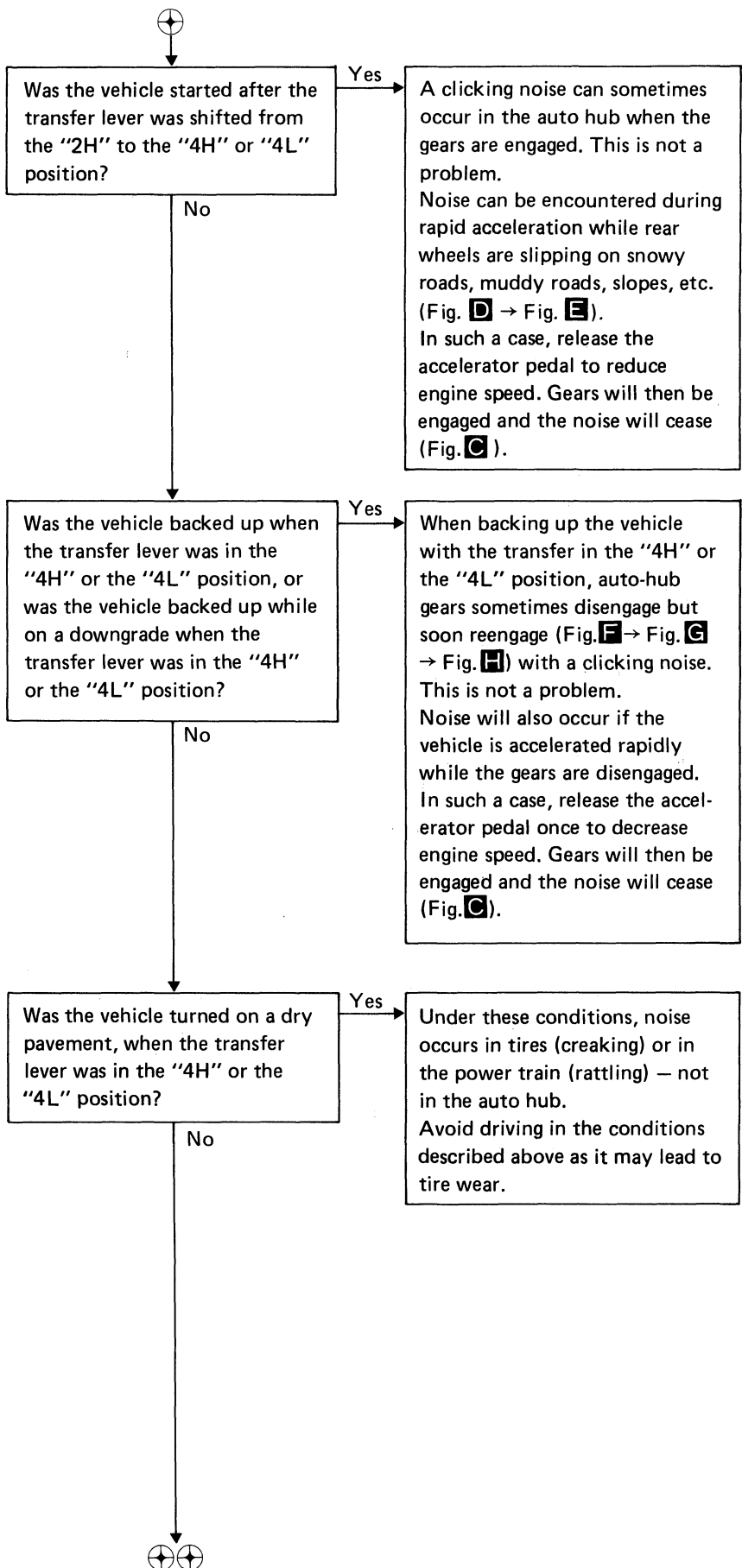
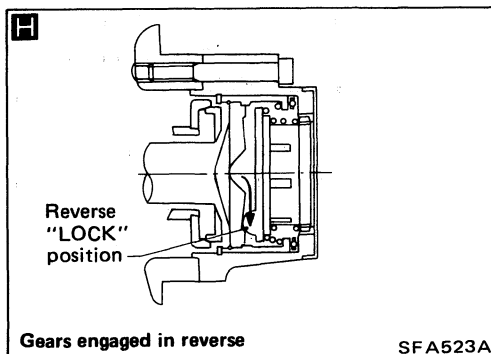
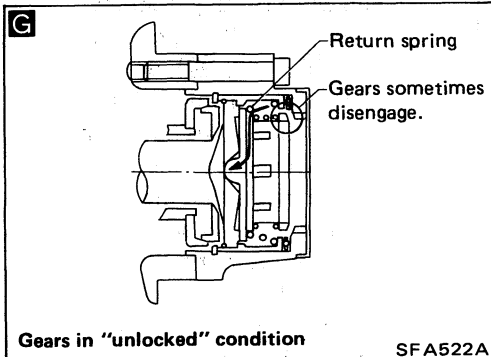
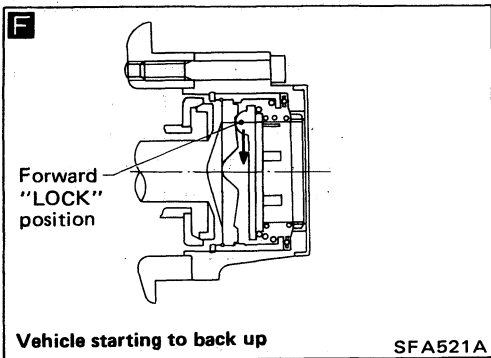
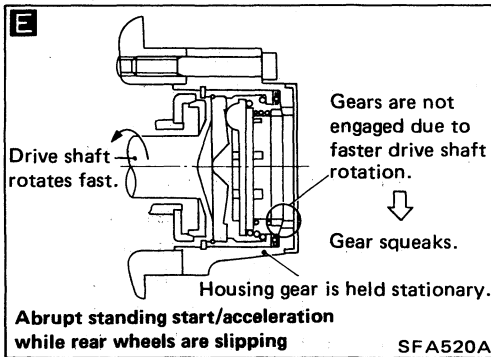
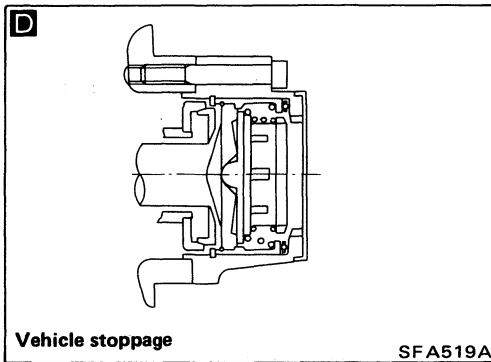

FRONT AXLE (4WD) — Auto-lock Free-running Hub

Trouble-shooting (Cont'd)

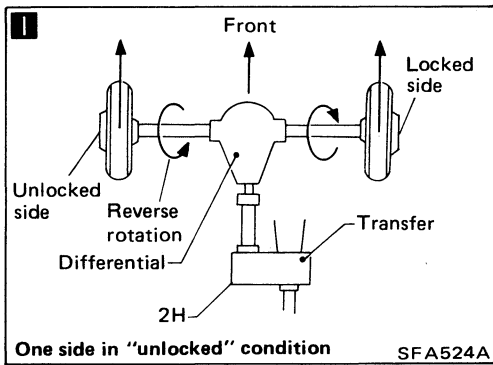

Was the vehicle moved in one direction after the vehicle was driven in another direction when the transfer lever was in the "4H" or the "4L" position and then returned to the "2H" position?

Yes

Auto-hub gears will disengage with a resultant noise (clicking). If the distance the vehicle is moved in the opposite direction is short [less than 1 m (3 ft)] or if the rotation angle of the left and right wheels is not the same (as in rounding a corner), gears on one side will disengage (Fig. I). Under this condition, a noise (crushing, etc.) might occur while driving in the "2H" position. If only gears on one side are unlocked, the locked drive shaft rotates at the same speed as wheels; however, the unlocked drive shaft is made to rotate in the reverse direction by the differential. This forces the auto hub's slide gear to lock in the reverse direction. As a result, noise occurs. If this happens, slowly move the vehicle straight back approximately 2 to 3 m (7 to 10 ft) with the transfer lever in the "2H" position to disengage the gears on the other side.

No

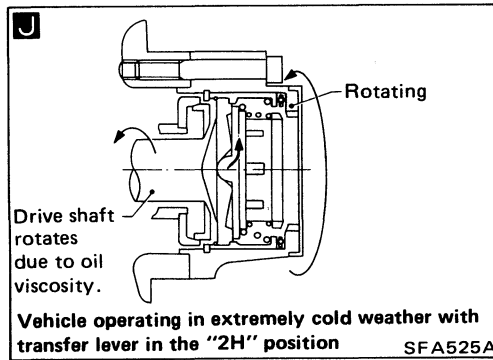

Was the vehicle driven with the transfer lever in the "2H" position in extremely cold weather?

Yes

In extremely cold weather (areas), the viscosity of differential oil is greater than in moderate weather. When the auto hubs are unlocked with the transfer lever set to the "2H" position, one auto hub can sometimes remain locked. This causes noise during operation. Noise can also occur in the auto hub when the front propeller shaft is rotated due to the viscosity resistance of the transfer fluid (Fig. J). In such a case, drive in the "4H" position for approximately 10 minutes until the vehicle warms up, and return the transfer lever to the "2H" position to eliminate the noise.

No

Disassemble and check the auto hub.
(Refer to page FA-18.)

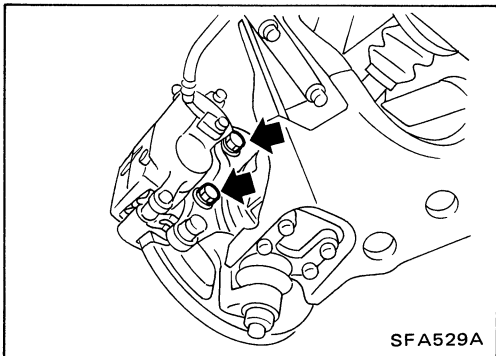

Removal and Installation

- Remove free-running hub assembly.
Refer to FRONT AXLE (4WD) — Auto-lock Free-running Hub or Manual-lock Free-running Hub.

- Remove brake caliper assembly.

Brake hose does not need to be disconnected from brake caliper. Be careful not to depress brake pedal, or piston will pop out. Make sure brake hose is not twisted.

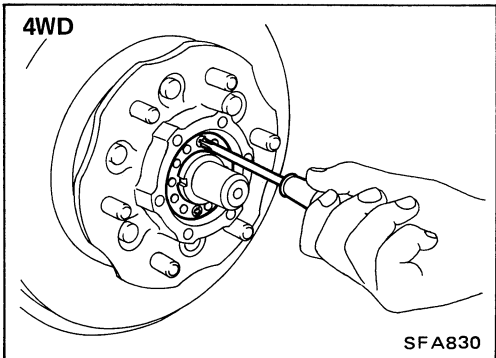

- Remove lock washer. — 4WD —

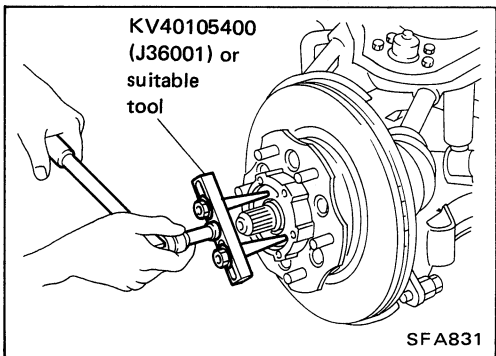

- Remove wheel bearing lock nut.
2WD: With suitable tool
4WD: With Tool

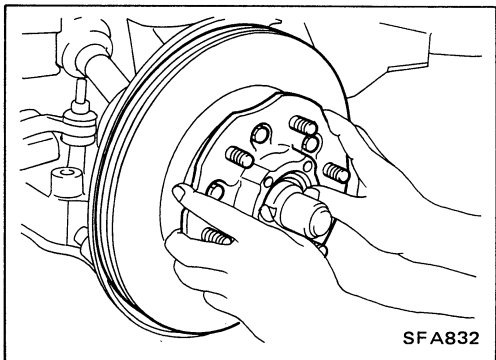

- Remove wheel hub and wheel bearing.
Be careful not to drop outer bearing.
- After installing wheel hub and wheel bearing, adjust wheel bearing preload.
Refer to PRELOAD ADJUSTMENT (2WD, 4WD) of Front Wheel Bearing in CHECK AND ADJUSTMENT — On-vehicle.

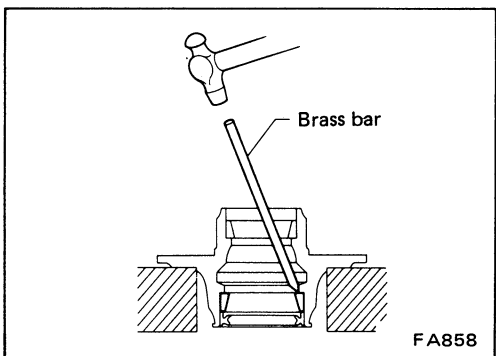

Disassembly

- Remove bearing outer races with suitable brass bar.

Inspection

Thoroughly clean wheel bearings and wheel hub.

WHEEL BEARING

- Make sure wheel bearing rolls freely and is free from noise, crack, pitting or wear.

WHEEL HUB

- Check wheel hub for crack by using a magnetic exploration or dyeing test.

Assembly

- Install bearing outer race with Tool until it seats in hub.

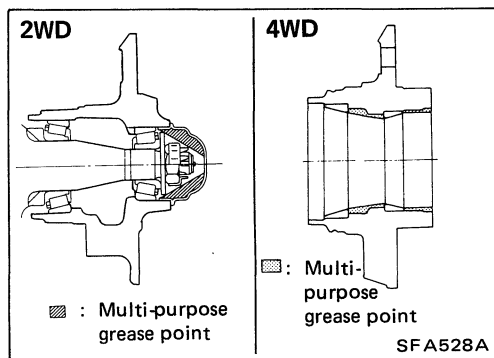
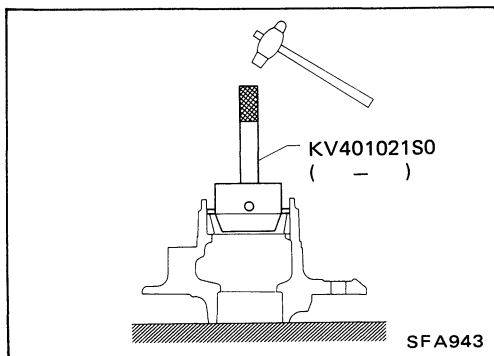

- Pack multi-purpose grease to hub and hub cap.

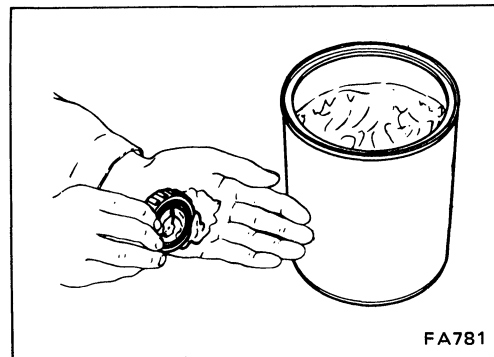

- Apply multi-purpose grease to each bearing cone.

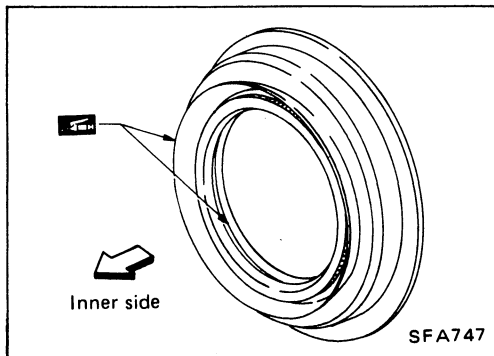

- Pack grease seal lip with multi-purpose grease, then install it into wheel hub with suitable drift.

FRONT AXLE — Knuckle Spindle

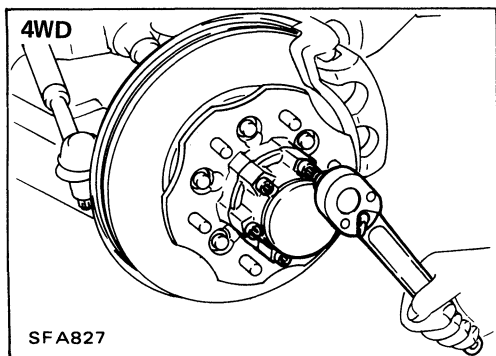

Removal

- Remove free-running hub assembly. — 4WD —
Refer to FRONT AXLE (4WD) — Auto-lock Free-running Hub or Manual-lock Free-running Hub.

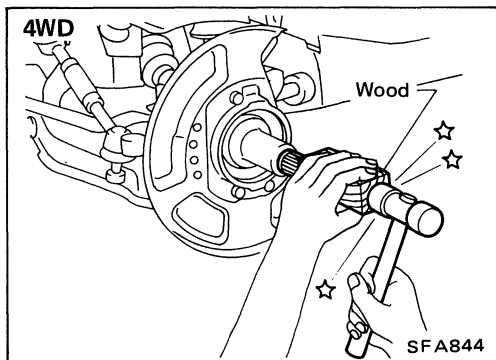

- Separate drive shaft from knuckle spindle by slightly tapping drive shaft end. — 4WD —

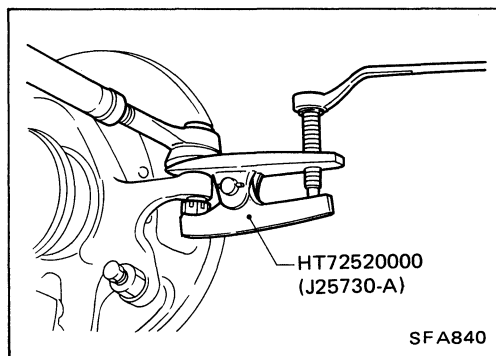

- Separate tie-rod from knuckle spindle with Tool.
Install stud nut conversely on stud bolt so as not to damage stud bolt.

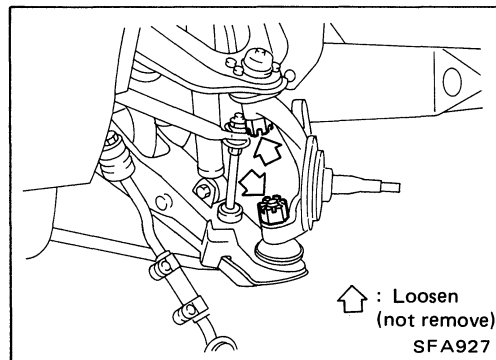

- Separate knuckle spindle from ball joints.
(1) Loosen (not remove) upper and lower ball joint tightening nuts.

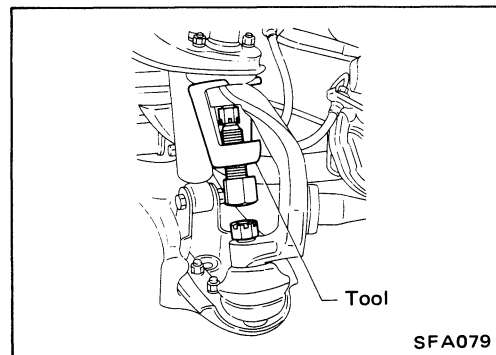

- (2) Separate knuckle spindle from upper and lower ball joint studs with Tool.
During above operation, never remove ball joint nuts which are loosened in step (1) above.

Tool:

- | | | |
|-----|------------|-------------|
| 2WD | ST29020001 | (J24319-01) |
| 4WD | HT72520000 | (J25730-A) |

FRONT AXLE — Knuckle Spindle

Removal (Cont'd)

- (3) Remove ball joint tightening nuts.
Support lower link with jack.
- (4) Remove knuckle spindle from upper and lower links.

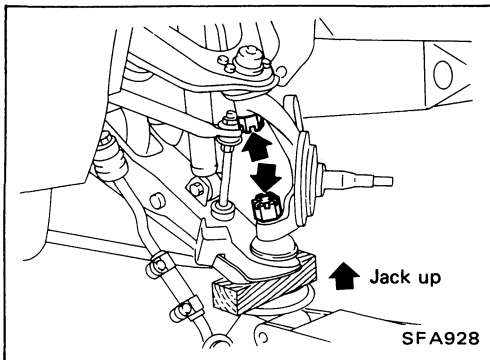

Inspection

KNUCKLE SPINDLE

- Check knuckle spindle for deformation, cracks or other damage by using a magnetic exploration or dyeing test.

BEARING SPACER — 2WD —

- Check bearing spacer for damage.

NEEDLE BEARING — 4WD —

- Check needle bearing for wear, scratches, pitting, flaking and burn marks.

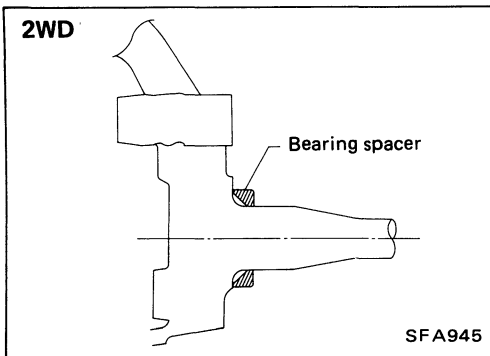

Installation

- Install bearing spacer onto knuckle spindle. — 2WD —
Make sure that bearing spacer is facing in proper direction.
Apply multi-purpose grease.

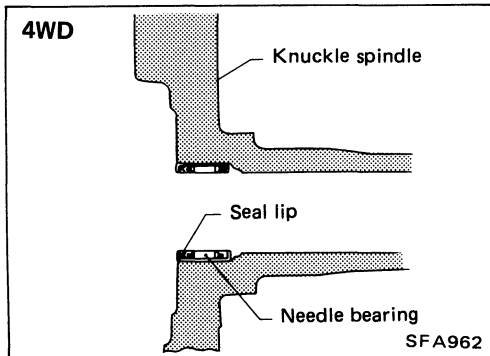

- Install needle bearing into knuckle spindle. — 4WD —
Make sure that needle bearing is facing in proper direction.
Apply multi-purpose grease.

FRONT AXLE — Knuckle Spindle

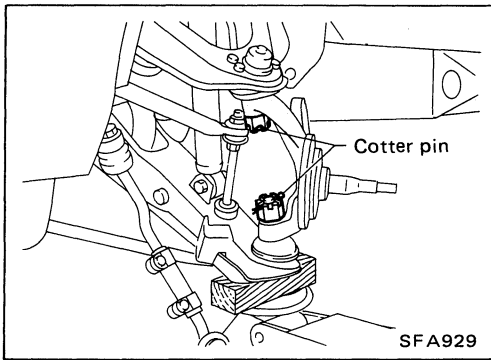

Installation (Cont'd)

- Install knuckle spindle to upper and lower ball joints with lower link jacked up.

CAUTION:

Make sure that oil or grease does not come into contact with tapered areas of ball joint and knuckle spindle and threads of ball joint.

- After installing knuckle spindle, adjust wheel bearing preload. Refer to PRELOAD ADJUSTMENT (2WD, 4WD) of Front Wheel Bearing in CHECK AND ADJUSTMENT — On-vehicle.

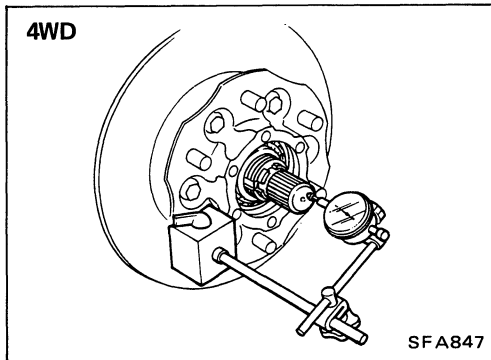

- After installing drive shaft, check drive shaft axial end play. Do not reuse snap ring once it has been removed. Refer to FRONT AXLE (4WD) — Drive shaft.

FRONT AXLE (4WD) — Drive Shaft

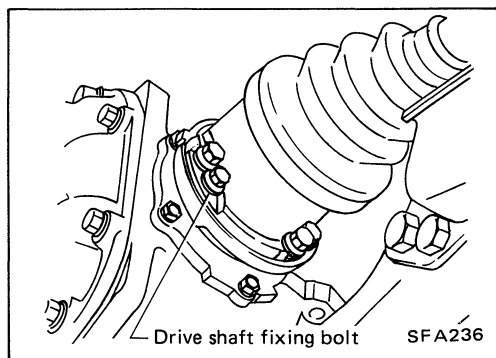
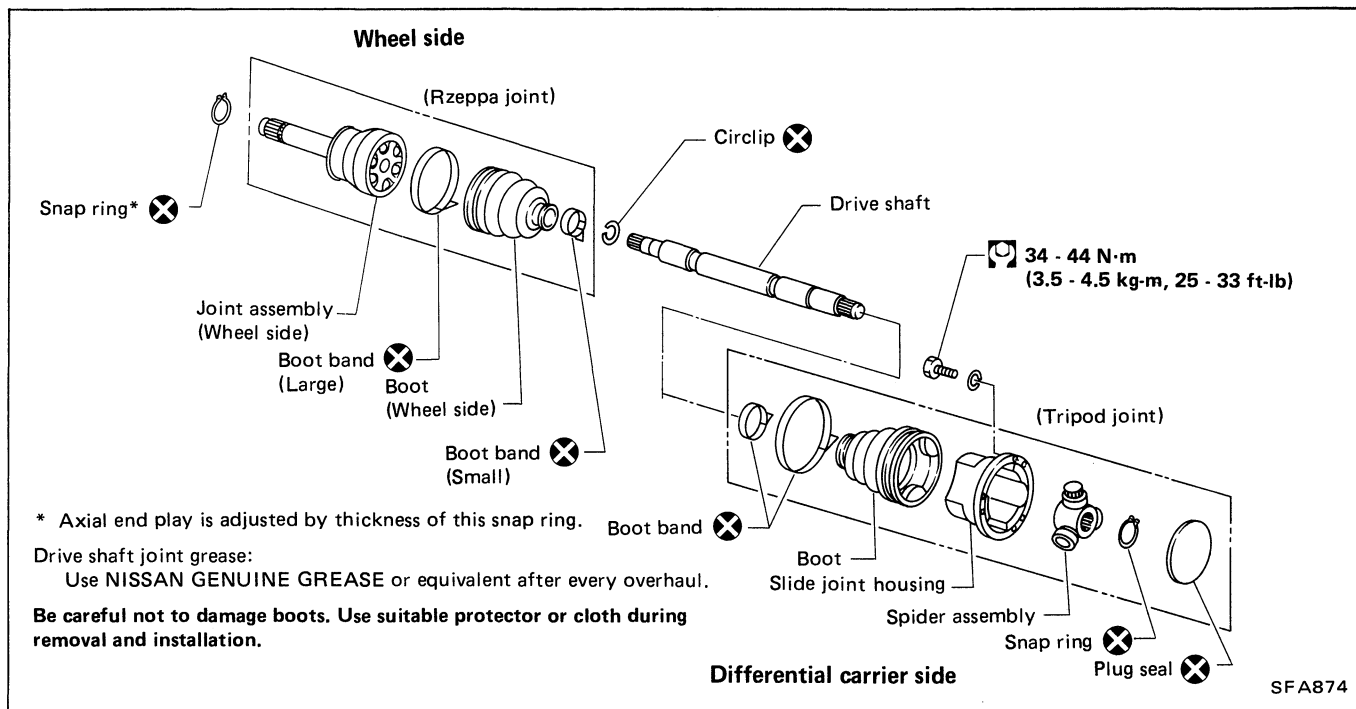

Removal

1. Remove bolts fixing drive shaft to differential carrier with brake pedal depressed.

2. Remove free-running hub assembly with brake pedal depressed. Refer to FRONT AXLE (4WD) — Auto-lock Free-running Hub or Manual-lock Free-running Hub.

- Remove brake caliper assembly without disconnecting brake hydraulic line.

Make sure that brake hose is not twisted.

- Remove tie-rod ball joint. Refer to FRONT AXLE (4WD) — Knuckle Spindle.

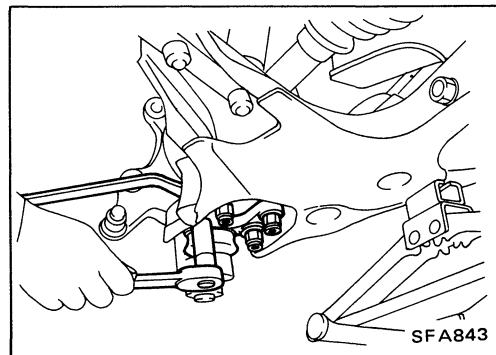

3. Remove nuts fixing lower ball joint on lower link.
Support lower link with jack.

FRONT AXLE (4WD) — Drive Shaft

Removal (Cont'd)

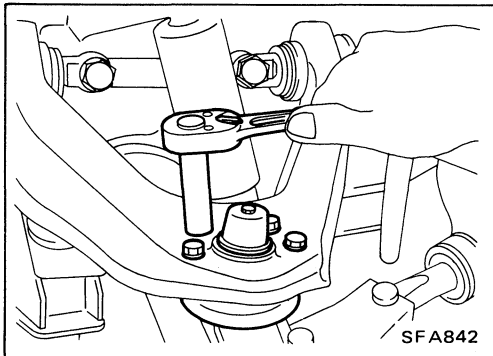

4. Remove upper ball joint fixing bolt.

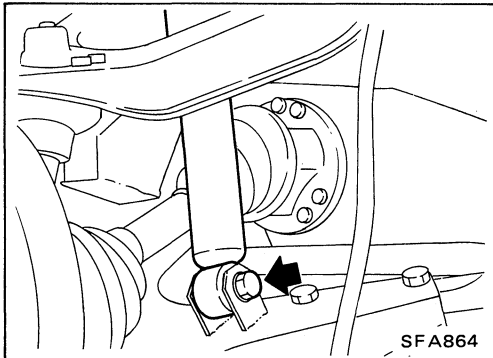

5. Remove shock absorber lower bolt.

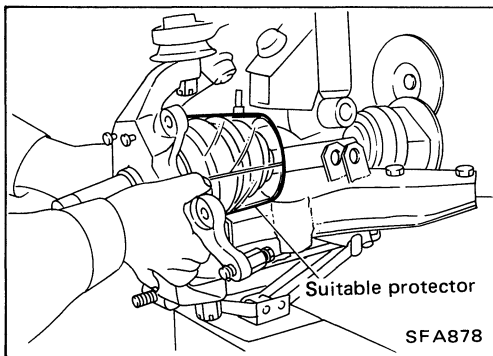

6. Remove drive shaft with knuckle.
Cover drive shaft boot with a suitable protector.

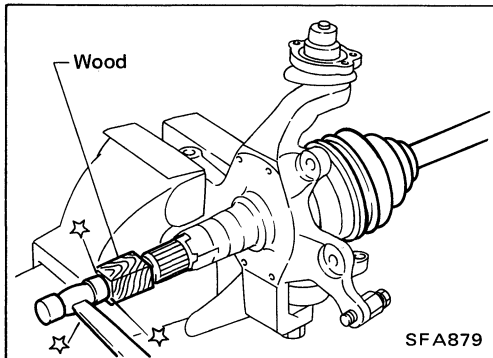

7. Separate drive shaft from knuckle by slightly tapping it.

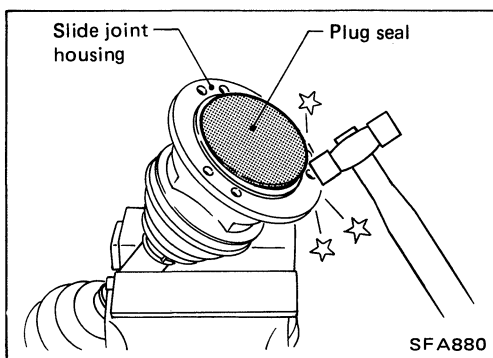

Disassembly

DIFFERENTIAL CARRIER SIDE

CAUTION:

Spider assembly is a non-disassembling type.

1. Remove plug seal from slide joint housing by lightly tapping around slide joint housing.

FRONT AXLE (4WD) — Drive Shaft

Disassembly (Cont'd)

2. Remove boot bands.

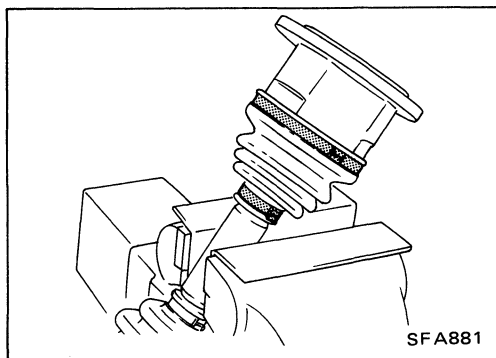

3. Move boot and slide joint housing toward wheel side, and put matching marks.

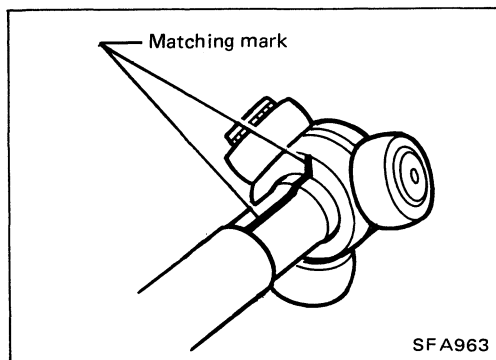

4. Pry off snap ring.

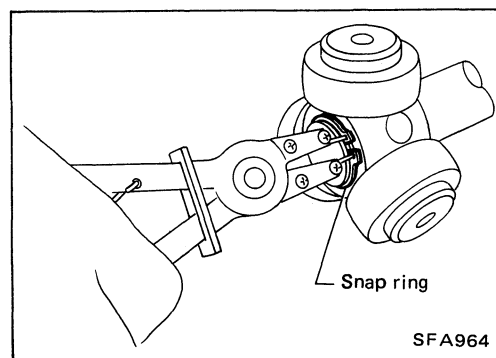

5. Detach spider assembly with press.

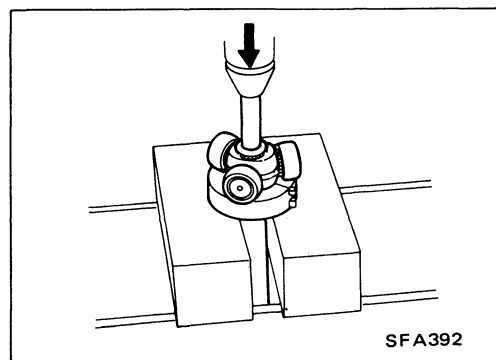

6. Draw out boot.

Cover drive shaft serration with tape so as not to damage the boot.

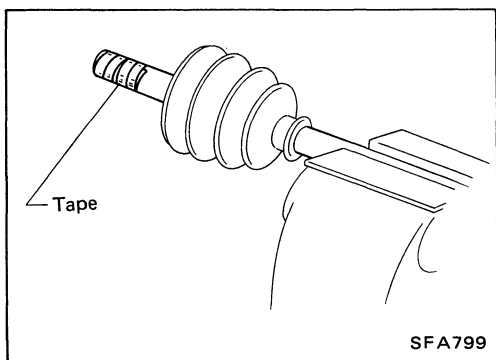

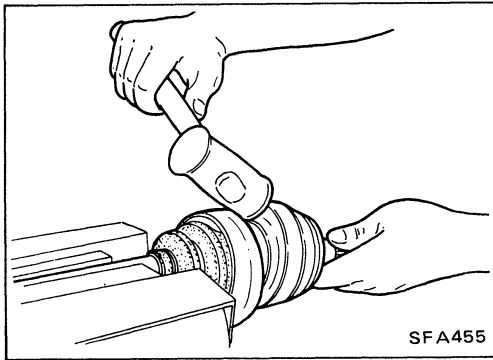

Disassembly (Cont'd)

WHEEL SIDE

CAUTION:

The joint on the wheel side employs a non-disassembling design.

- Before separating joint assembly, put matching marks on drive shaft and joint assembly.
- Remove boot bands.
- Separate joint assembly by lightly tapping it.

Inspection

Thoroughly clean all parts in cleaning solvent, and dry with compressed air. Check parts for evidence of deformation or other damage.

DRIVE SHAFT

Replace drive shaft if it is twisted or cracked.

BOOT

Check boot for fatigue, cracks, or wear. Replace boot with new boot bands.

JOINT ASSEMBLY (Differential carrier side)

- Check spider assembly for needle bearing and washer damage. Replace spider assembly if necessary.
- Check roller surfaces for scratches, wear or other damage. Replace if necessary.
- Check serration for deformation. Replace if necessary.
- Check slide joint housing for any damage. Replace if necessary.

JOINT ASSEMBLY (Wheel side)

Replace joint assembly if it is deformed or damaged.

Assembly

- After drive shaft has been assembled, ensure that it moves smoothly over its entire range without binding.
- Use NISSAN GENUINE GREASE or equivalent after every overhaul.

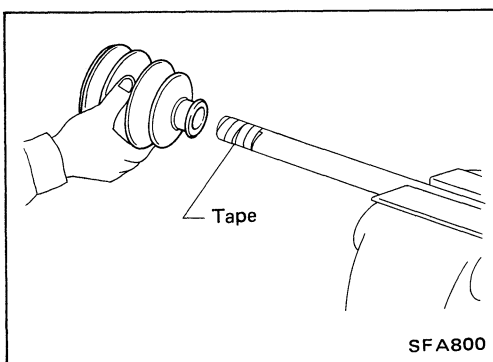

DIFFERENTIAL CARRIER SIDE

1. Install new small boot band, boot and side joint housing to drive shaft.

Cover drive shaft serration with tape so as not to damage boot during installation.

FRONT AXLE (4WD) — Drive Shaft

Assembly (Cont'd)

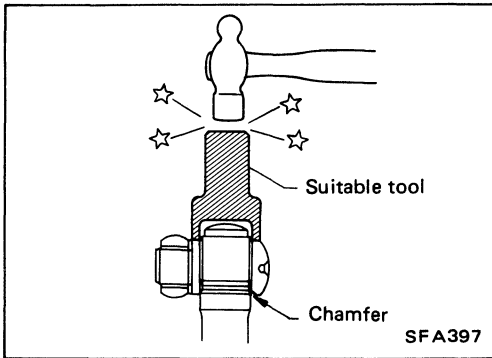

2. Install spider assembly securely, ensuring marks are properly aligned.
- Press-fit with spider assembly serration chamfer facing shaft.
3. Install new snap ring.

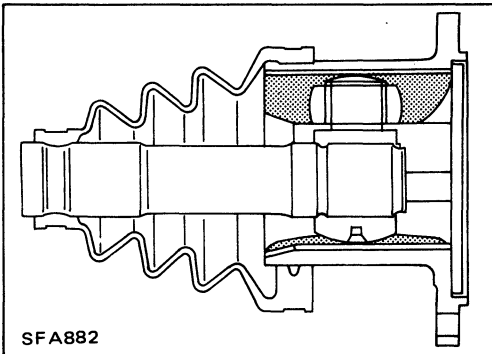

4. Pack with grease.
Specified amount of grease:
150 - 160 g (5.29 - 5.64 oz.)

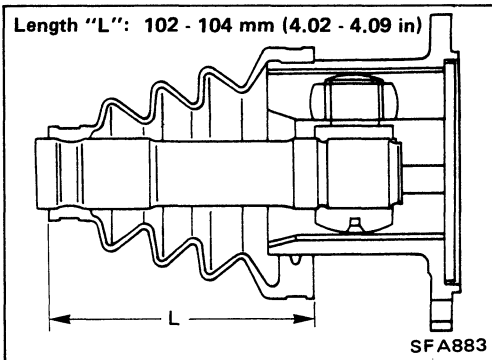

5. Set boot so that it does not swell and deform when its length is "L".
Make sure that boot is properly installed on the drive shaft groove.

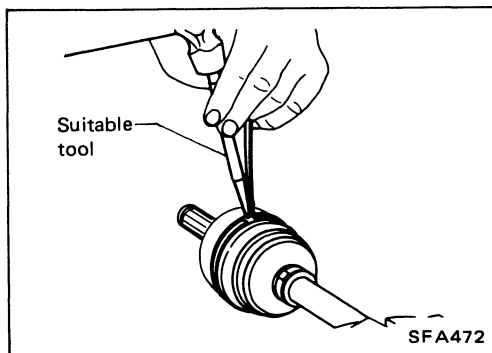
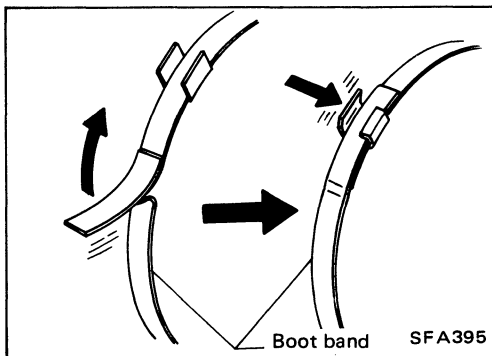

6. Lock new larger boot band securely with a suitable tool, then lock new smaller boot band.
7. Install new plug seal to slide joint housing by lightly tapping it.
Apply sealant to mating surface of plug seal.

FRONT AXLE (4WD) — Drive Shaft

Assembly (Cont'd)

WHEEL SIDE

1. Install new small boot band and boot on drive shaft.

Cover drive shaft serration with tape so as not to damage boot during installation.

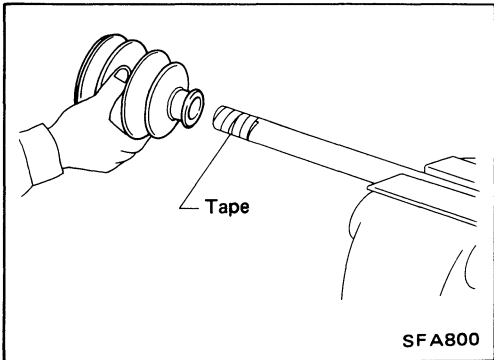

2. Set joint assembly onto drive shaft by lightly tapping it. Install joint assembly securely, ensuring marks which were made during disassembly are properly aligned.

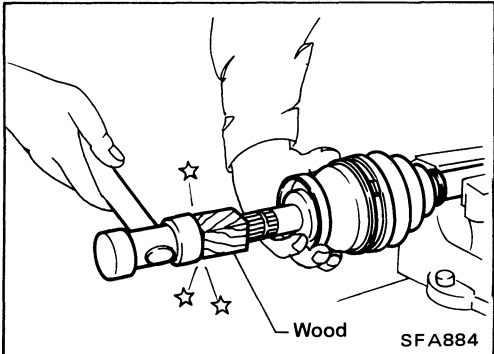

3. Pack drive shaft with specified amount of grease.

Specified amount of grease:

210 - 220 g (7.41 - 7.76 oz)

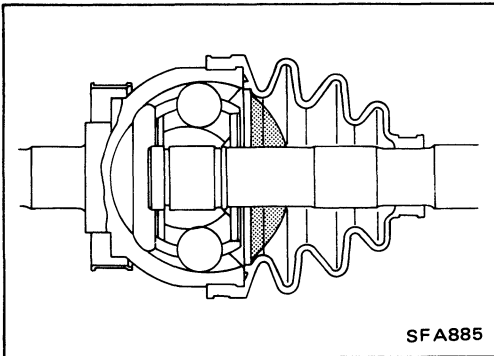

4. Set boot so that it does not swell and deform when its length is "L".

Make sure that boot is properly installed on the drive shaft groove.

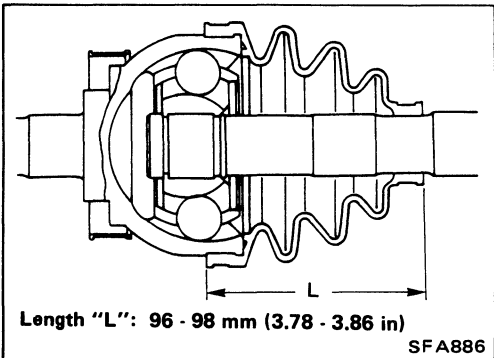

5. Lock new larger boot band securely with a suitable tool.

6. Lock new smaller boot band.

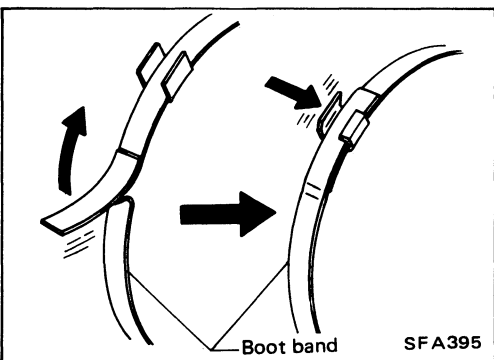

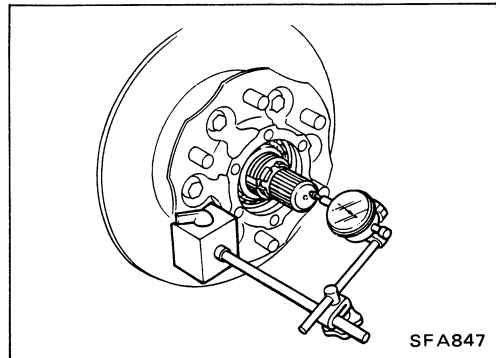
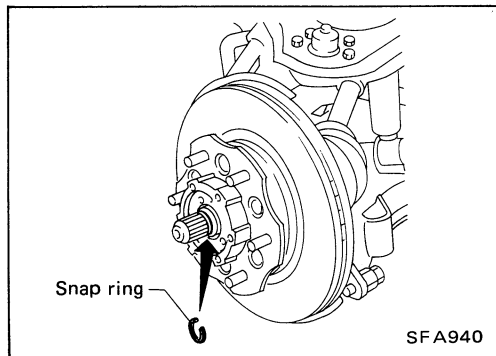
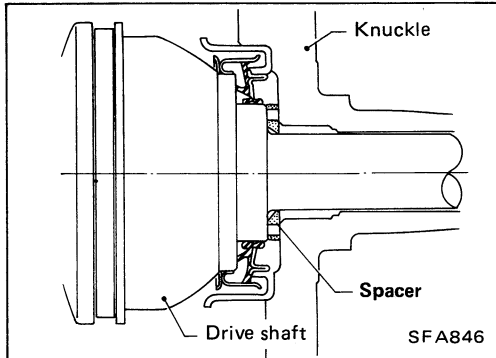
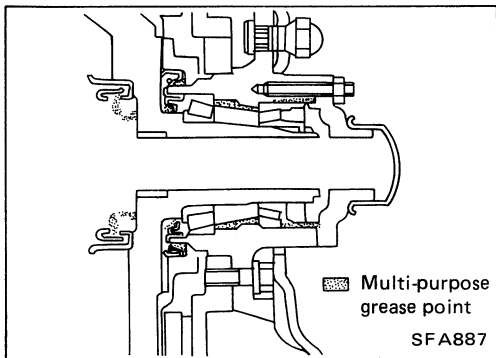

Installation

- Apply multi-purpose grease.

- Install bearing spacer onto drive shaft.
Make sure that bearing spacer is facing in proper direction.

- When installing drive shaft, adjust drive shaft axial end play by selecting a suitable snap ring.

- (1) Temporarily install new snap ring on drive shaft in the same thickness as it was installed before removal.

- (2) Set dial gauge on drive shaft end.

- (3) Measure axial end play of drive shaft.

Axial end play: 0.1 - 0.3 mm (0.004 - 0.012 in)

- (4) If axial end play is not within the specified limit, select another snap ring.

1.1 mm (0.043 in)

1.3 mm (0.051 in)

1.5 mm (0.059 in)

1.7 mm (0.067 in)

1.9 mm (0.075 in)

2.1 mm (0.083 in)

2.3 mm (0.091 in)

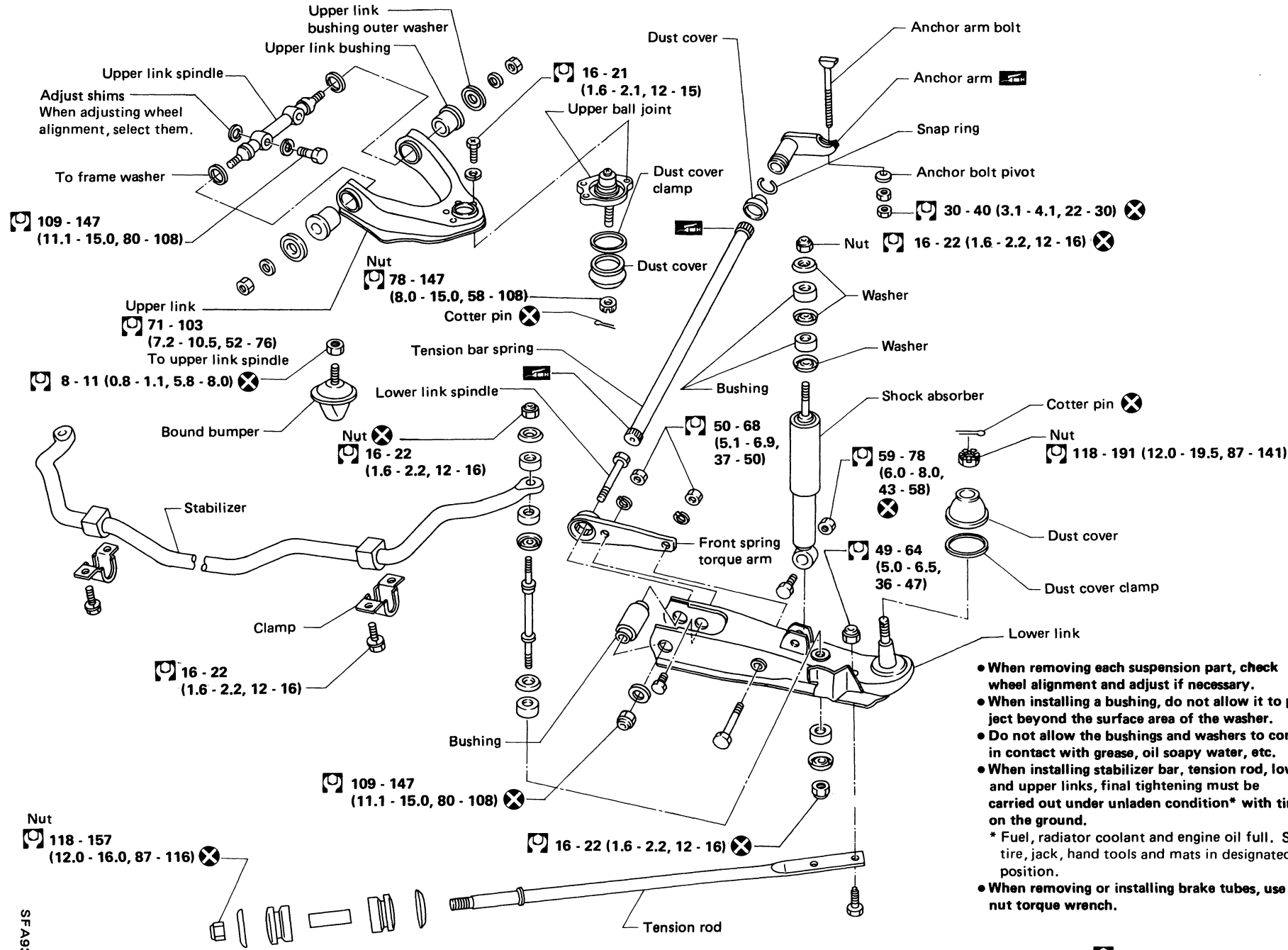

- When removing each suspension part, check wheel alignment and adjust if necessary.
 - When installing a bushing, do not allow it to project beyond the surface area of the washer.
 - Do not allow the bushings and washers to come in contact with grease, oil soapy water, etc.
 - When installing stabilizer bar, tension rod, lower and upper links, final tightening must be carried out under unladen condition* with tires on the ground.
- * Fuel, radiator coolant and engine oil full. Spare tire, jack, hand tools and mats in designated position.
- When removing or installing brake tubes, use flare nut torque wrench.

: N·m (kg·m, ft·lb)

FA-34

SFA930

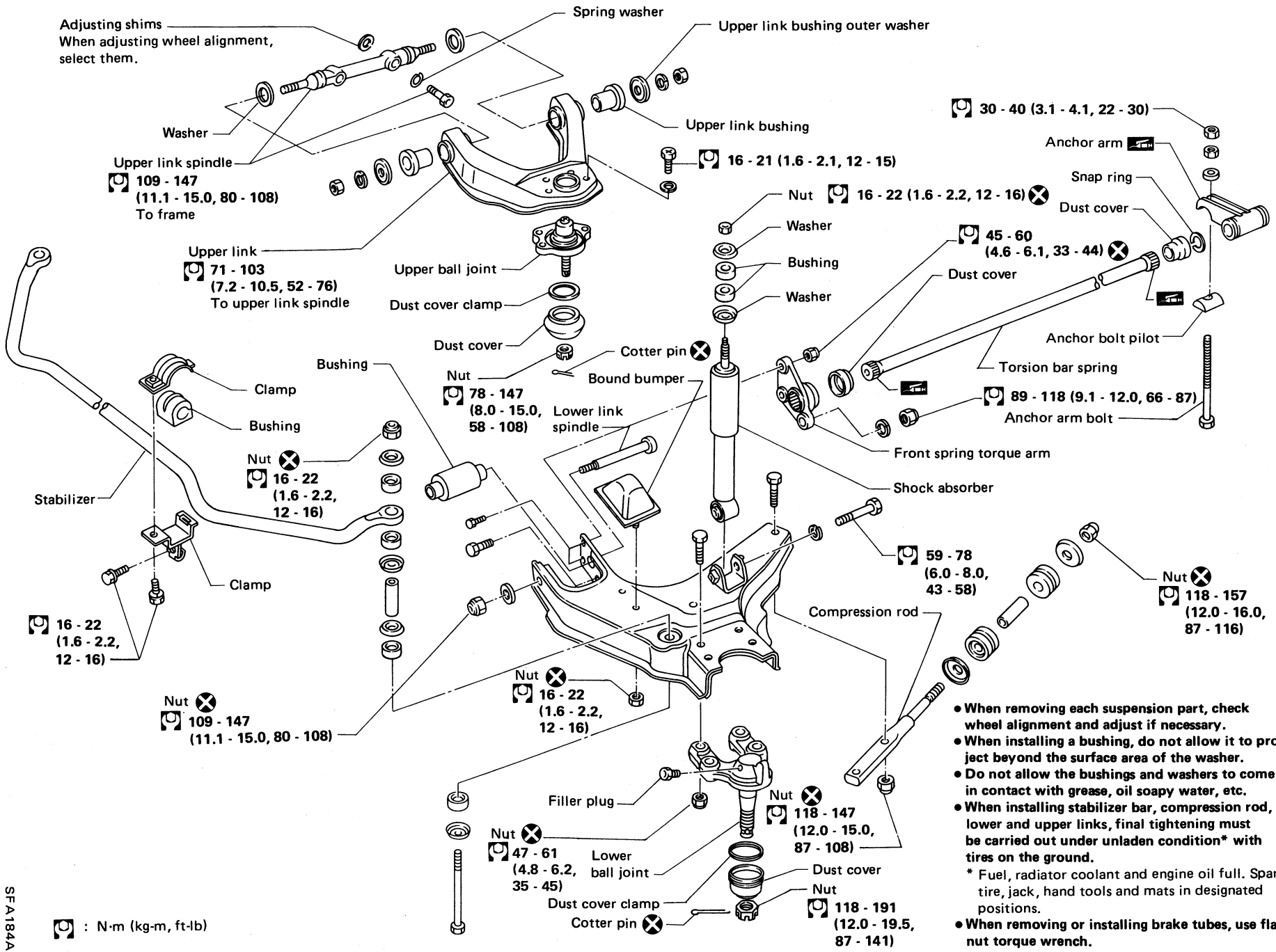

Adjusting shims
When adjusting wheel alignment,
select them.

Upper link spindle
109 - 147
(11.1 - 15.0, 80 - 108)
To frame

Upper link
71 - 103
(7.2 - 10.5, 52 - 76)
To upper link spindle

Nut
16 - 22
(1.6 - 2.2,
12 - 16)

Nut
109 - 147
(11.1 - 15.0, 80 - 108)

Nut
16 - 22
(1.6 - 2.2,
12 - 16)

Nut
47 - 61
(4.8 - 6.2,
35 - 45)

Nut
16 - 22 (1.6 - 2.2, 12 - 16)

30 - 40 (3.1 - 4.1, 22 - 30)

Nut
16 - 22 (1.6 - 2.2, 12 - 16)

45 - 60
(4.6 - 6.1, 33 - 44)

89 - 118 (9.1 - 12.0, 66 - 87)

59 - 78
(6.0 - 8.0,
43 - 58)

Nut
118 - 157
(12.0 - 16.0,
87 - 116)

Nut
118 - 147
(12.0 - 15.0,
87 - 108)

Nut
118 - 191
(12.0 - 19.5,
87 - 141)

: N·m (kg·m, ft·lb)

FA-35

SFA184A

FRONT SUSPENSION

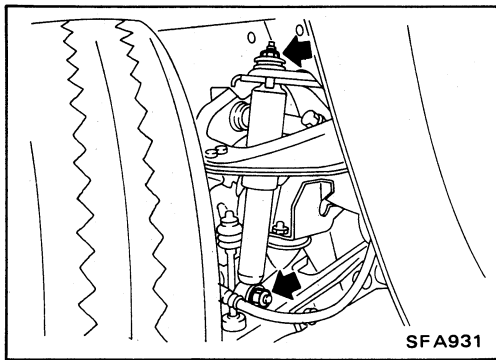

Shock Absorber

REMOVAL AND INSTALLATION

When removing and installing shock absorber, do not allow oil or grease to come into contact with rubber parts.

INSPECTION

Wash all parts, except for nonmetallic parts, clean with suitable solvent and dry with compressed air.

Blow dirt and dust off of nonmetallic parts with compressed air.

- Check for oil leakage and cracks. Replace if necessary.
- Check piston rod for cracks, deformation or other damage. Replace if necessary.
- Check rubber parts for wear, cracks, damage or deformation. Replace if necessary.

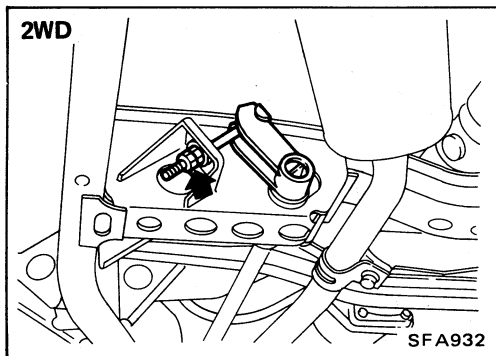

Torsion Bar Spring

REMOVAL

- Remove adjusting nut.

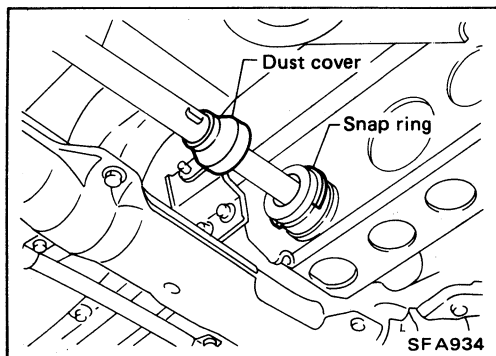
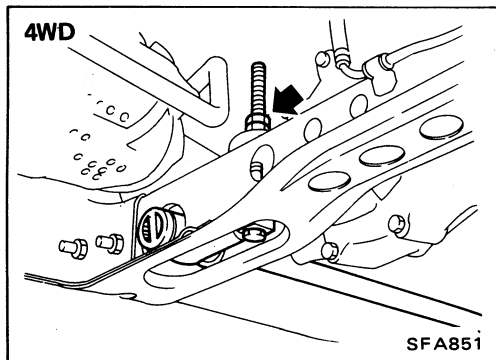

- Move dust cover, then detach snap ring from anchor arm.
- Pull out anchor arm rearward, then withdraw torsion bar spring rearward. – 2WD –
- Remove torque arm. – 2WD –

FRONT SUSPENSION

Torsion Bar Spring (Cont'd)

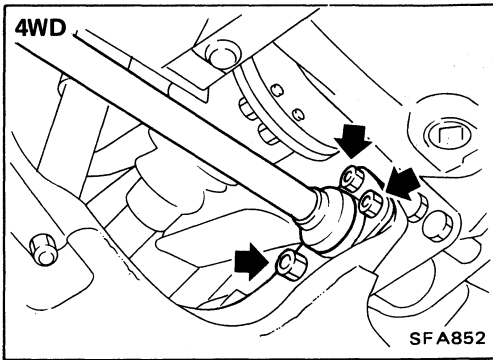

- Remove torque arm fixing nuts, then withdraw torsion bar spring forward with torque arm. — 4WD —

INSPECTION

- Check torsion bar spring for wear, twist, bend and other damage.
- Check serrations of each part for cracks, wear, twist and other damage.
- Check dust cover for cracks.

INSTALLATION AND ADJUSTMENT

Adjustment of anchor arm adjusting nut is in tightening direction only.

Do not adjust by loosening anchor arm adjusting nut.

1. Install torque arm to lower link. — 2WD —
2. Coat multi-purpose grease on the serration of torsion bar spring.

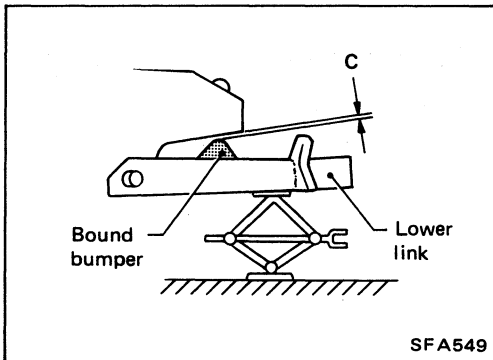

3. Place lower link in the position where bound buffer clearance "C" is 0.

Clearance "C": 0 mm (0 in)

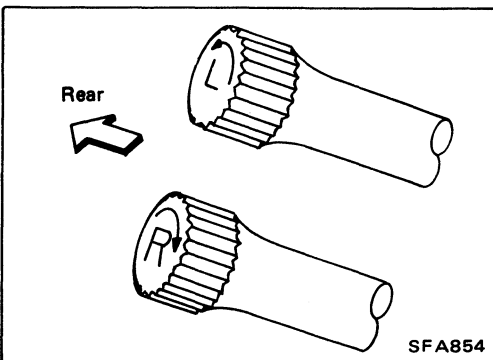

4. Install torsion bar spring. — 2WD —
- Install torsion bar spring with torque arm. — 4WD —
- Be sure to install right and left torsion bar springs correctly.

FRONT SUSPENSION

Torsion Bar Spring (Cont'd)

5. Set anchor arm.

Standard length "G":

2WD 6 - 18 mm (0.24 - 0.71 in)

4WD 50 - 60 mm (1.97 - 2.36 in)

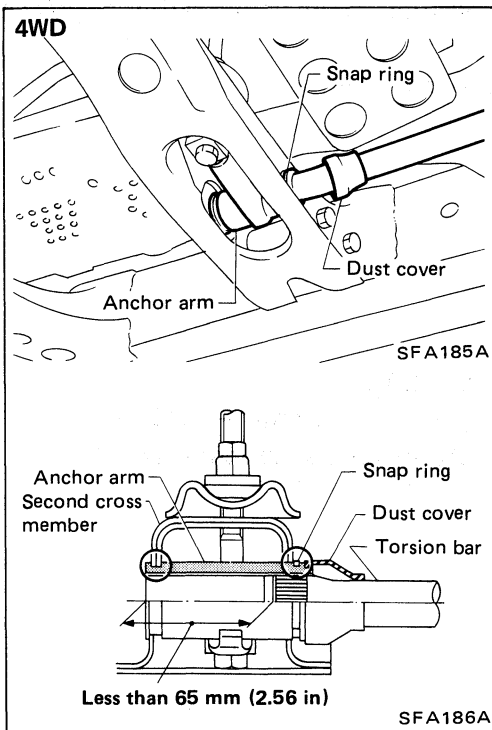
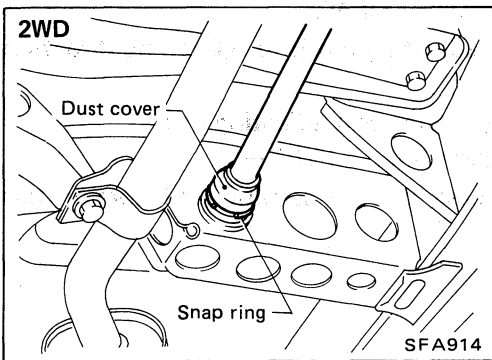
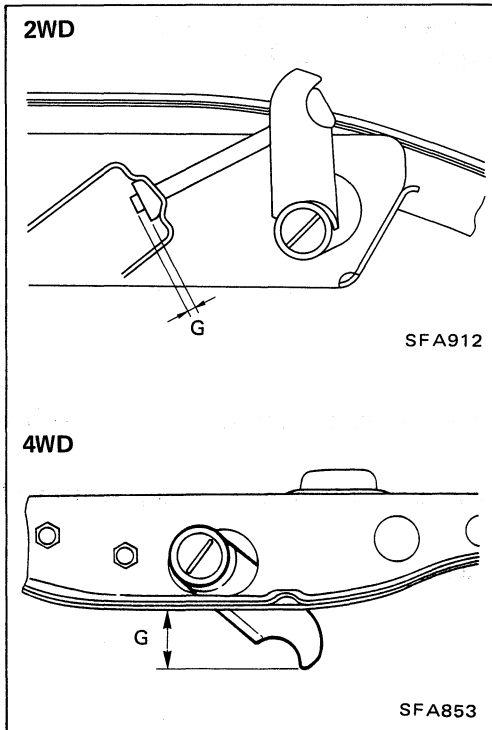

6. Install snap ring to anchor arm and dust cover.

—2WD—

Make sure that snap ring is properly installed on the anchor arm groove.

—4WD—

Make sure that snap ring and anchor arm are properly installed.

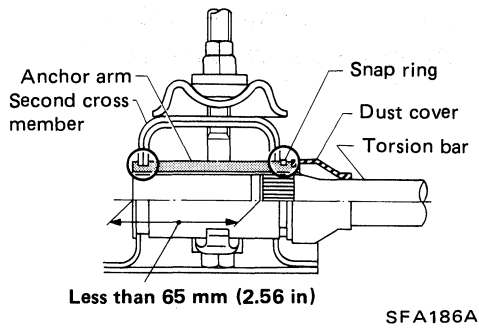

FRONT SUSPENSION

Torsion Bar Spring (Cont'd)

7. Tighten anchor arm adjusting nut to get L dimension.

Standard length "L":

2WD

For Heavy Duty, Cab & Chassis and
STD models

35 mm (1.38 in)

Except above models

49 mm (1.93 in)

4WD 77 mm (3.03 in)

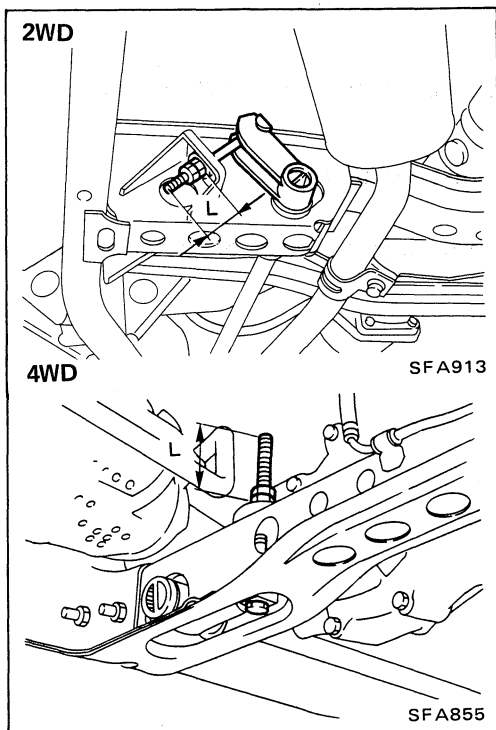

8. Bounce vehicle with tires on ground (Unladen) to eliminate friction of suspension.

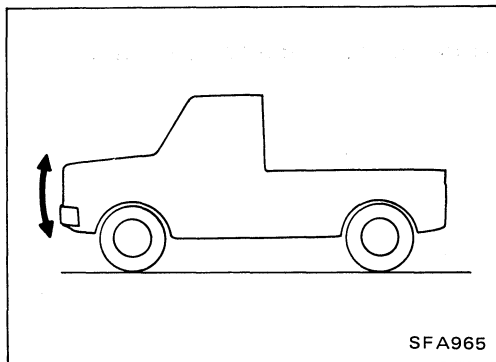

9. Measure vehicle posture "H".

$H = A - B$ mm (in) "Unladen"

Refer to S.D.S.

(1) Exercise the front suspension by bouncing the front of the vehicle 4 or 5 times to ensure that the vehicle is in a neutral height attitude.

(2) Measure vehicle posture ... Dimension "H".

(Refer to **A** SERVICE CHECKING on S.D.S.)

(3) If height of the vehicle is not as specified, adjust vehicle posture.

(Refer to **A** SERVICE SETTING on S.D.S.)

(4) Check wheel alignment if necessary.

(Refer to **B** SERVICE CHECKING on S.D.S.)

10. If "H" dimension is not within the specified value, readjust vehicle posture using anchor arm adjusting nut.

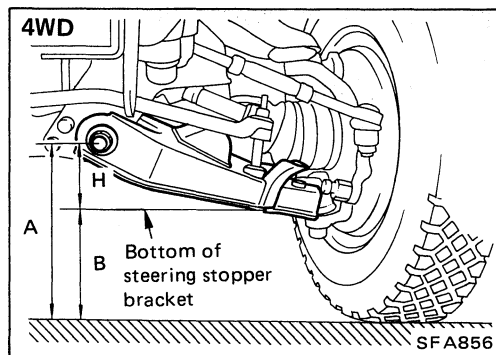
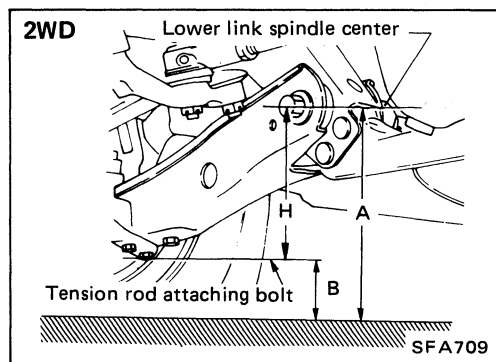

FRONT SUSPENSION

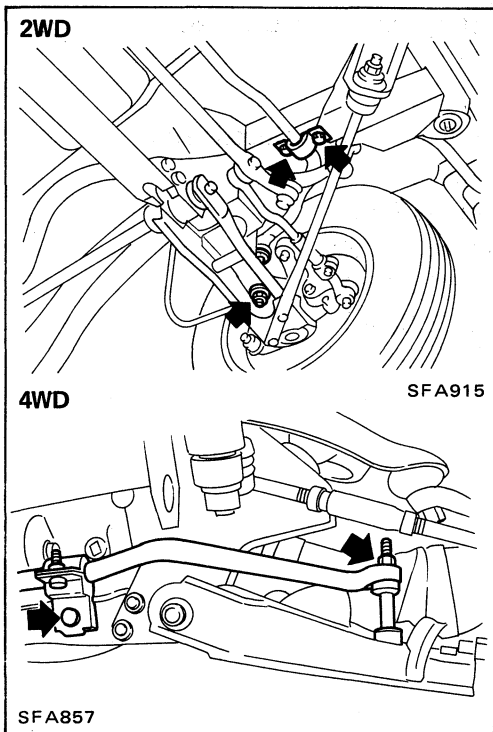

Stabilizer Bar

REMOVAL

- Remove stabilizer bar connecting bolt and a clamp bolt.

INSPECTION

- Check stabilizer bar for twist and deformation. Replace if necessary.
- Check rubber bushing for cracks, wear or deterioration. Replace if necessary.

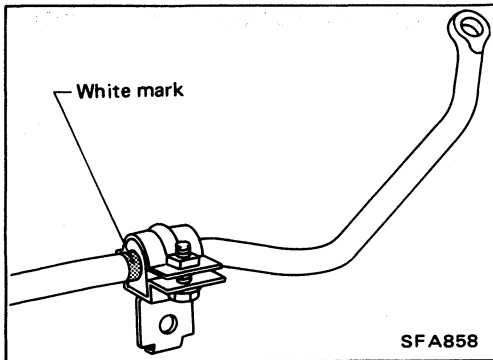

INSTALLATION

- Install bushing outside white mark painted on stabilizer.

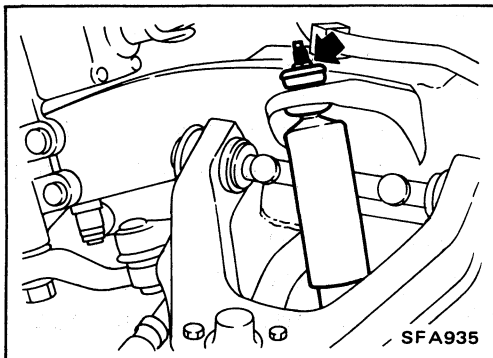

Upper Link

REMOVAL

- Remove shock absorber upper fixing nut.

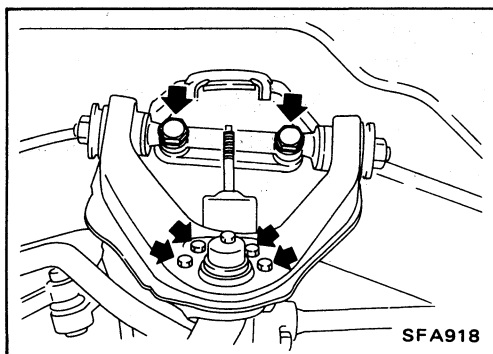

- Remove bolts fixing upper ball joint on upper link.
- Support lower link with jack.**
- Remove upper link spindle fixing bolts.

FRONT SUSPENSION

Upper Link (Cont'd)

INSTALLATION

- Tighten upper link spindle with camber adjusting shims.
- After fitting, check dimensions "A" and "B".
 - A: 110 mm (4.33 in)
 - B: 32 mm (1.26 in)

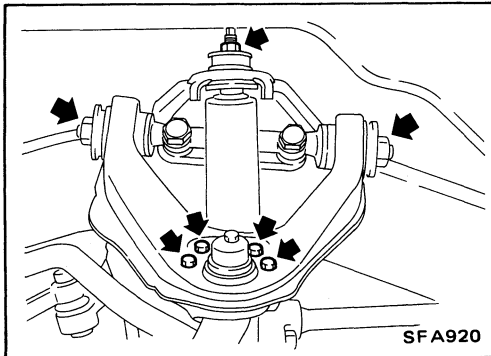
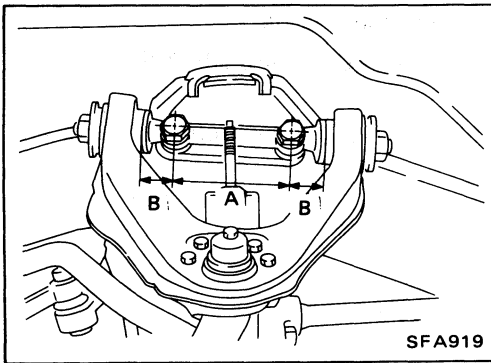

- Install upper ball joint on upper link.
- Install shock absorber upper fixing nut.
- Tighten upper link spindle lock nuts under unladen condition with tires on ground.
- After installing, check wheel alignment. Adjust if necessary. Refer to Front Wheel Alignment of CHECK AND ADJUSTMENT – On-vehicle.

DISASSEMBLY

- Press out upper link spindle with bushings.

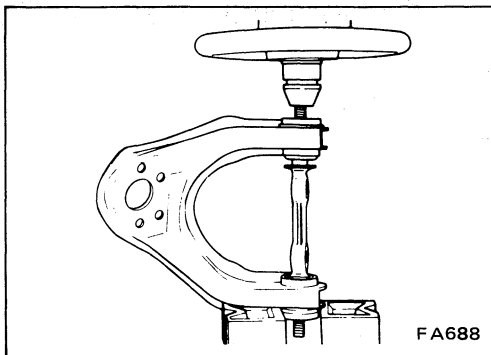

INSPECTION

- Check upper link spindle and rubber bushings for damage. Replace if necessary.
- Check upper link for deformation or cracks. Replace if necessary.

ASSEMBLY

- Apply soapsuds to rubber bushing.
- Press upper link bushing.

Press bushing so that flange of bushing securely contacts end surface of upper link collar.

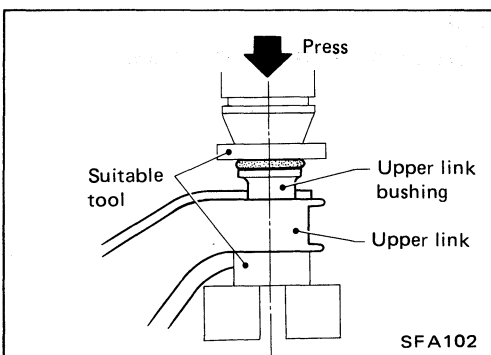

FRONT SUSPENSION

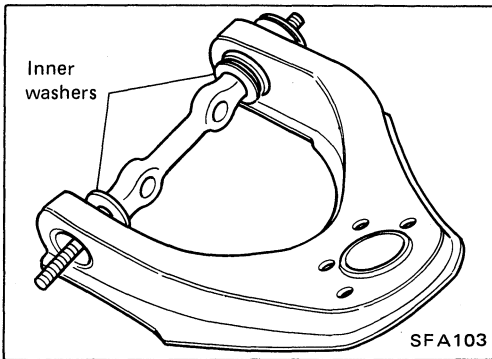

Upper Link (Cont'd)

- Insert upper link spindle and inner washers.
Install inner washers with rounded edges facing inward.
- Press another bushing.
Press bushing so that flange of bushing securely contacts end surface of upper link collar.

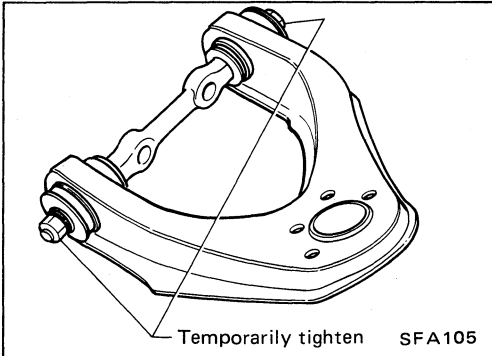

- Temporarily tighten nuts.

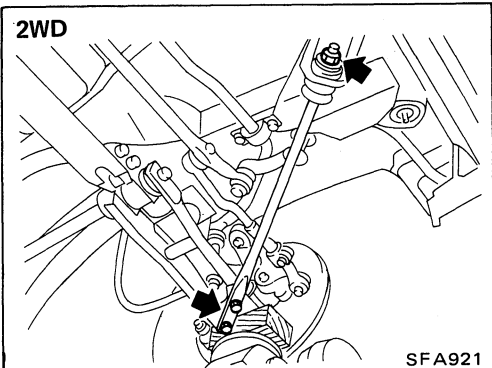

Tension Rod (2WD) or Compression Rod (4WD)

REMOVAL AND INSTALLATION

- Remove fixing nuts on lower link and frame.
Support lower link with jack.

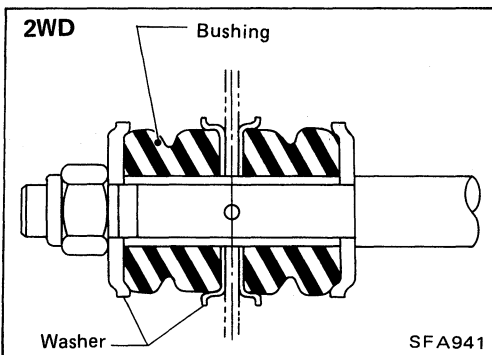
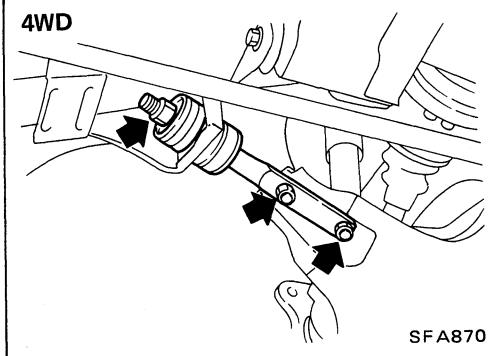

- Install tension rod. — 2WD —
Make sure that bushings and washers are installed properly.

FRONT SUSPENSION

Tension Rod (2WD) or Compression Rod (4WD) (Cont'd)

- Install compression rod. – 4WD –
Make sure that bushings and washers are installed properly.

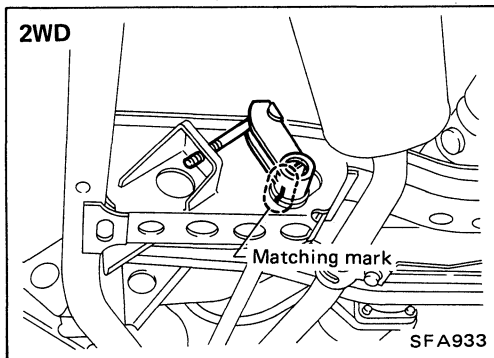
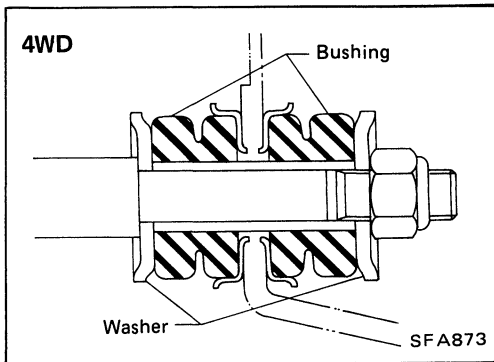

Lower Link

REMOVAL AND INSTALLATION

- Remove torsion bar spring. Refer to REMOVAL of Torsion Bar Spring.

Make matching mark on anchor arm and crossmember when loosening adjusting nut until there is no tension on torsion bar spring.

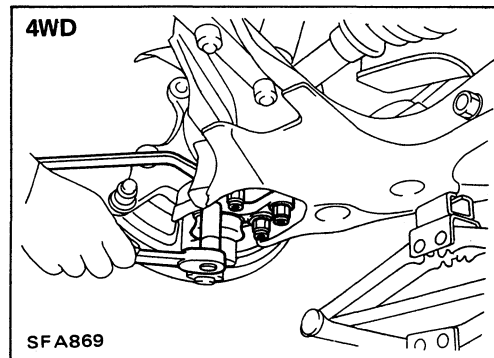
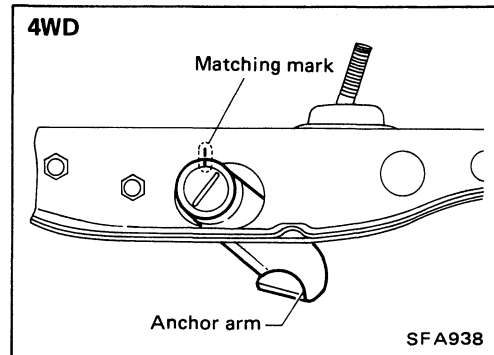

- Separate lower link ball joint from knuckle spindle. – 2WD –
Refer to FRONT AXLE – Knuckle Spindle.
- Separate lower ball joint from lower link. – 4WD –

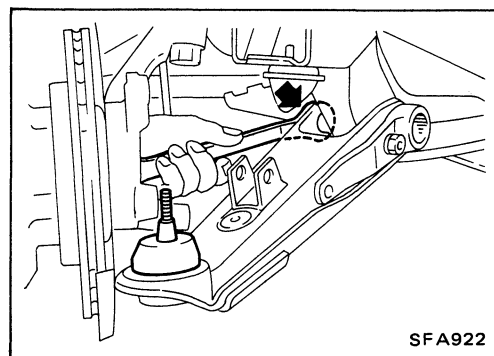

- Remove front lower link fixing nut.

FRONT SUSPENSION

Lower Link (Cont'd)

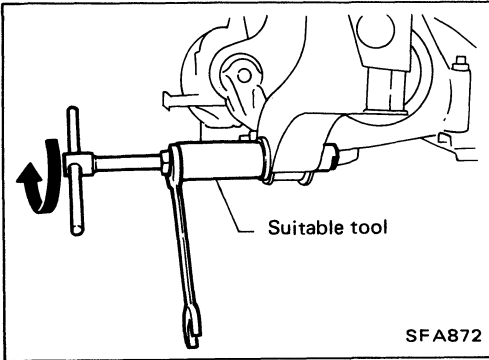

- Remove bushing of lower link spindle from frame with suitable tool.
- When installing bushing, apply soapy water on bushing.
- After installing lower link, adjust wheel alignment and vehicle height. Refer to Front Wheel Alignment of CHECK AND ADJUSTMENT – On-vehicle.

INSPECTION

Lower link and lower link spindle

- Check lower link and lower link spindle for deformation or cracks. Replace if necessary.

Lower link bushing

- Check bushing for distortion or other damage. Replace if necessary.

Upper Ball Joint and Lower Ball Joint

REMOVAL AND INSTALLATION

- Separate knuckle spindle from upper and lower links. Refer to FRONT AXLE – Knuckle Spindle.

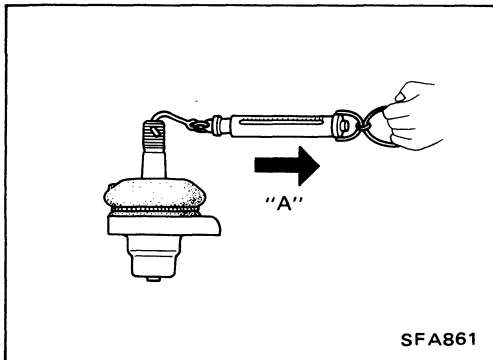

INSPECTION

- Check ball joint for turning torque "A".

Upper ball joint:

[2WD]

[4WD]

31.87 - 199.38 N

(3.25 - 20.33 kg, 7.17 - 44.83 lb)

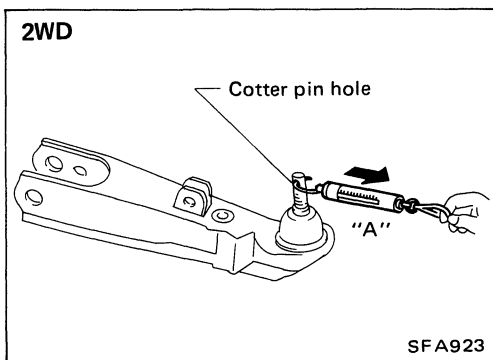

2WD

Lower ball joint:

[2WD]

13.63 - 54.43 N

(1.39 - 5.55 kg, 3.06 - 12.24 lb)

FRONT SUSPENSION

Upper Ball Joint and Lower Ball Joint (Cont'd)

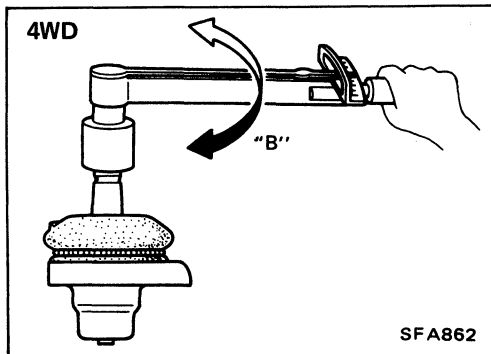
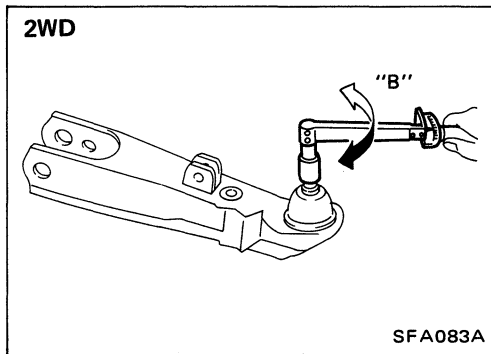
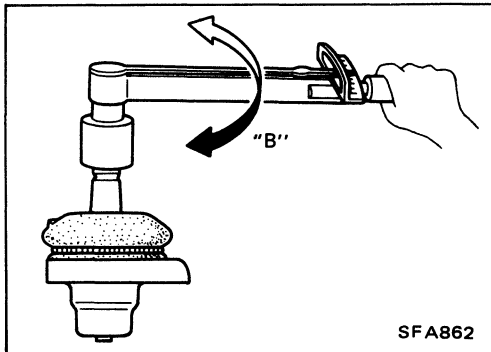
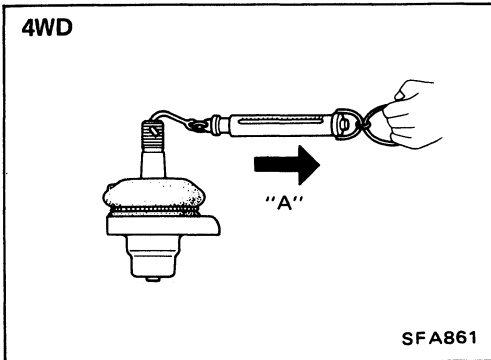

[4WD]

0 - 67.7 N

(0 - 6.9 kg, 0 - 15.2 lb)

If turning torque A is not within above specifications, replace ball joint assembly.

- Check ball joint for turning torque "B".

Upper ball joint:

[2WD]

[4WD]

1.0 - 4.9 N·m

(10 - 50 kg-cm, 8.7 - 43.4 in-lb)

Lower ball joint:

[2WD]

1.0 - 3.9 N·m

(10 - 40 kg-cm, 8.7 - 34.7 in-lb)

[4WD]

0 - 4.9 N·m

(0 - 50 kg-cm, 0 - 43 in-lb)

If turning torque B is not within above specifications, replace ball joint assembly.

FRONT SUSPENSION

Upper Ball Joint and Lower Ball Joint (Cont'd)

- Check ball joint for vertical end play "C" (on vehicle).

Upper ball joint:

[2WD]

[4WD]

1.6 mm (0.063 in) or less

- (1) Jack up front of vehicle and set the stands.
- (2) Clamp dial indicator onto transverse link and place indicator tip on lower edge of brake caliper.
- (3) Make sure front wheels are straight and brake pedal is depressed.
- (4) Place a pry bar between transverse link and inner rim of road wheel.
- (5) While pushing and releasing pry bar, observe maximum dial indicator value.
- (6) Replace lower link or lower ball joint if ball joint movement is beyond specifications.

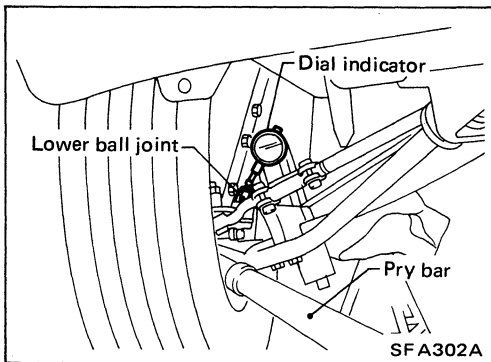

Lower ball joint:

[2WD]

1.6 mm (0.063 in) or less

[4WD]

0.5 mm (0.020 in) or less

- (1) Jack up front of vehicle and set the stands.
 - (2) Remove road wheel.
 - (3) Clamp dial indicator onto upper link and place indicator tip on knuckle near ball joint.
 - (4) Jack up lower link [Approx. 20 mm (0.79 in)].
 - (5) Place a pry bar between upper link and upper link spindle.
 - (6) While pushing and releasing pry bar, observe maximum dial indicator value.
 - (7) Replace upper ball joint if ball joint movement is beyond specifications.
- Check dust cover for damage.
Replace dust cover and dust cover clamp if necessary.

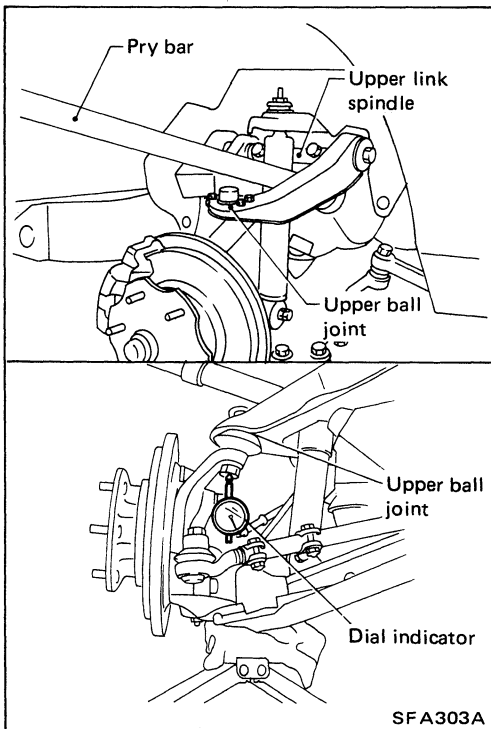

ADJUSTABLE SHOCK ABSORBER

Description

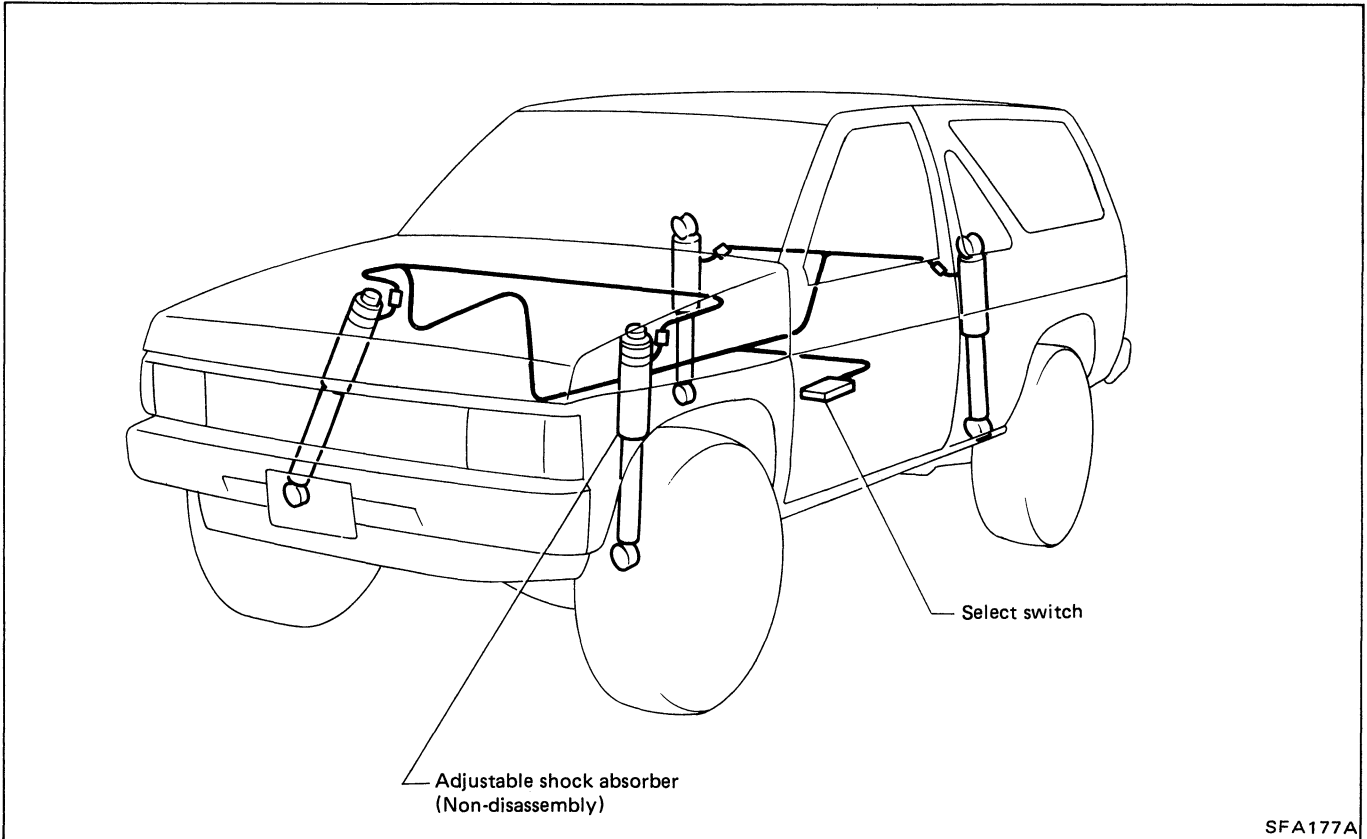

SFA177A

Schematic

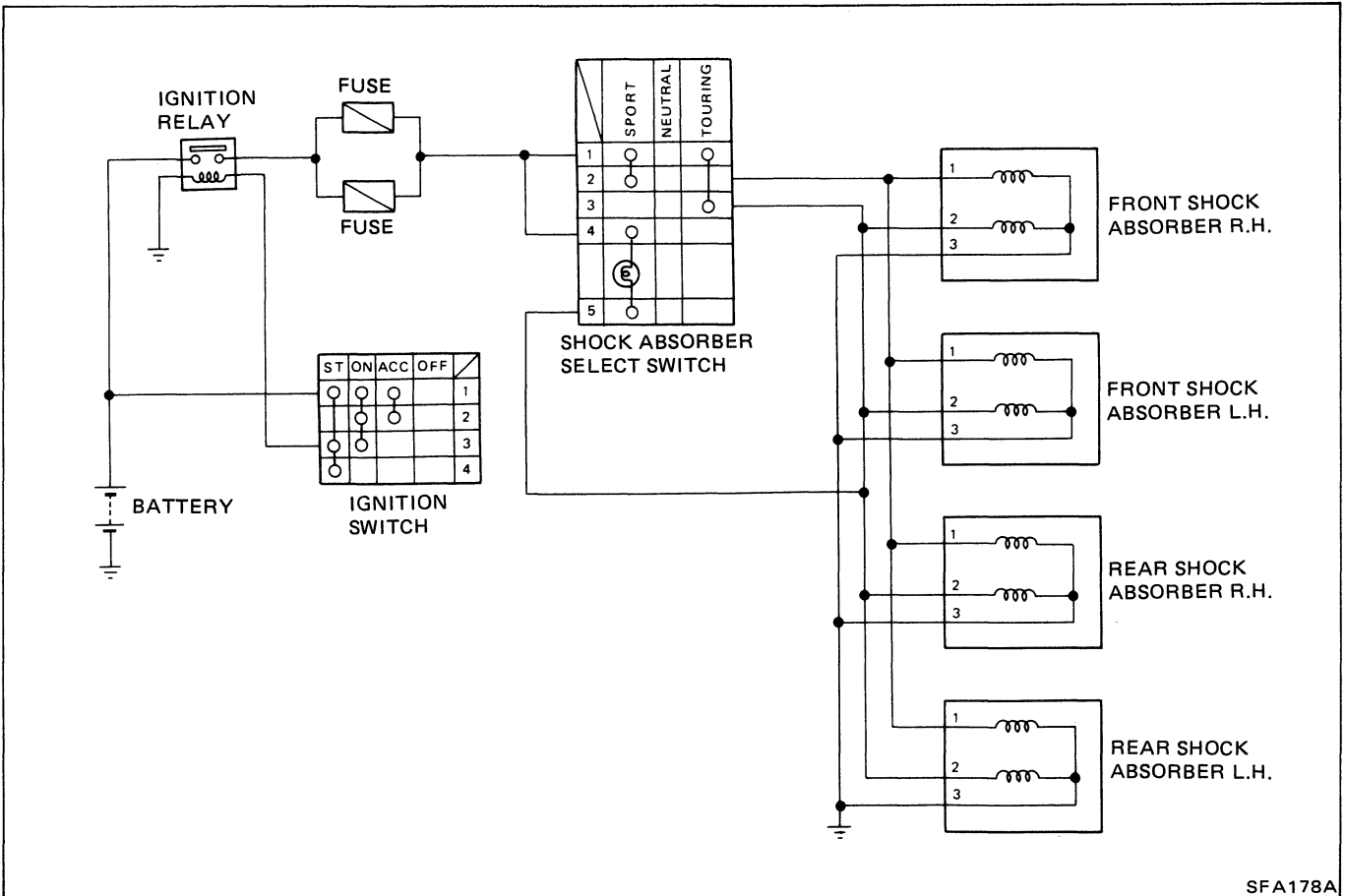

SFA178A

ADJUSTABLE SHOCK ABSORBER

Wiring Diagram

SHOCK ABSORBER SELECT SWITCH

	SPORT	N	TOURING
1			
2	○		
3			○
4		⊕	
5			○

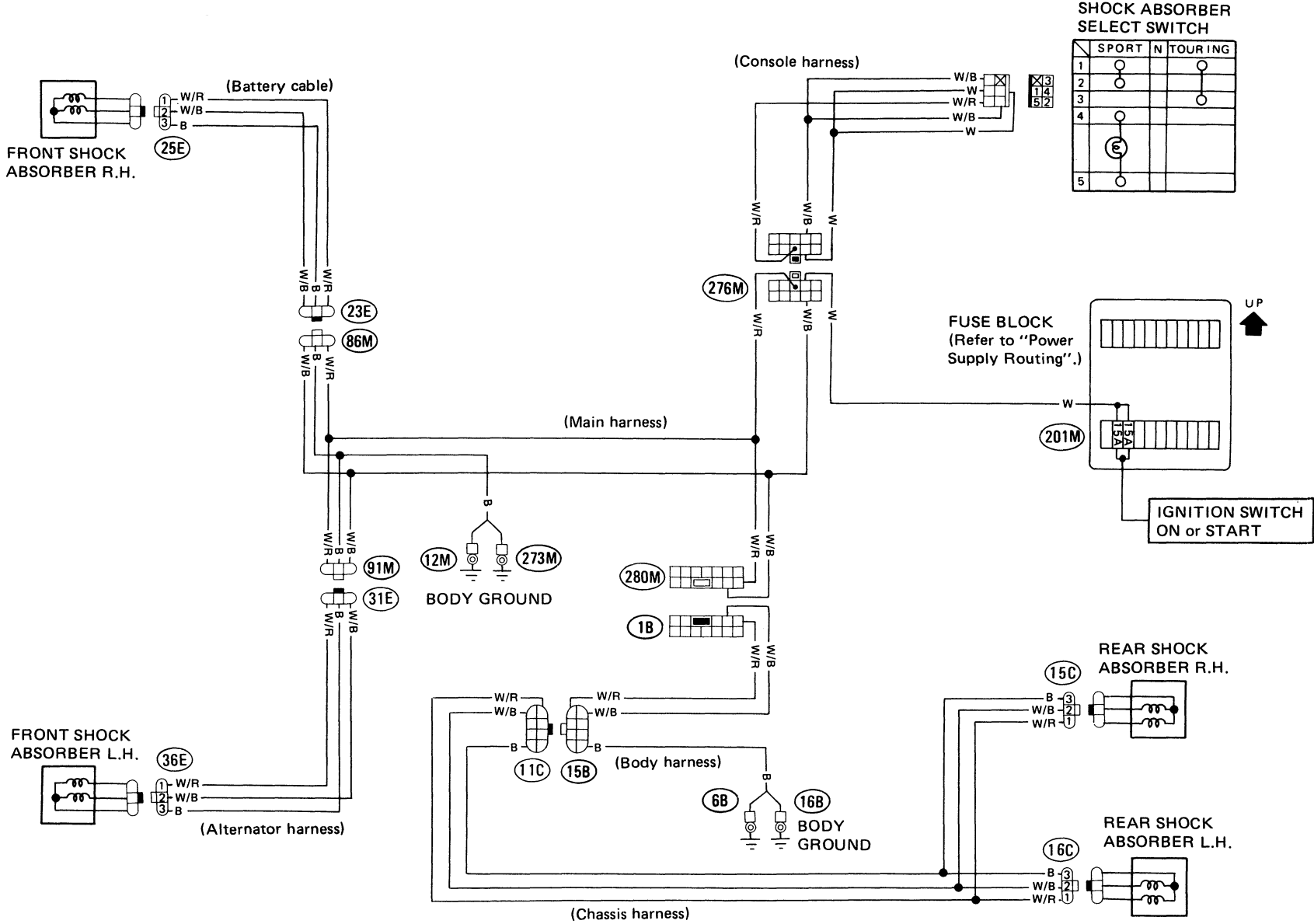

FA-48

SFA378A

ADJUSTABLE SHOCK ABSORBER

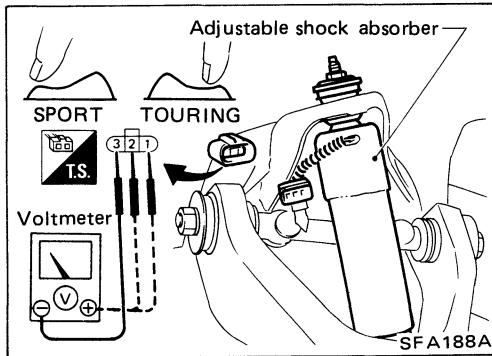
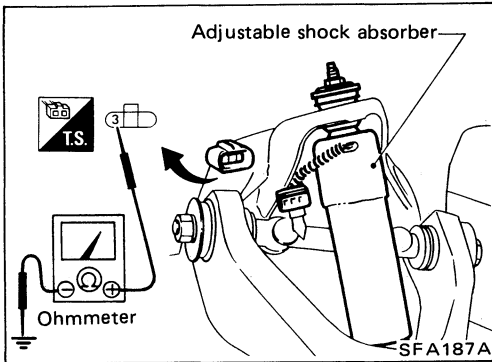

Terminal check

POWER SUPPLY CIRCUIT CHECK

1. Disconnect adjustable shock absorber connector.
2. Check for continuity between terminal ③ and body ground.

Ohmmeter terminal		Continuity
(+)	(-)	
③	Body ground	Yes

3. Connect a voltmeter from terminal side.
4. Measure voltage across terminal ③ and terminals ② & ①.

Voltmeter (+)	Voltmeter (-)	Voltage	Select switch position
			①
		0	Release the switch.
②	③	Approx. 12V	Push the TOURING end of the switch continuously.
		Approx. 12V	Release the switch.

SELECT SWITCH CHECK

1. Disconnect select switch connector, then connect an ohmmeter to switch.
2. Check for continuity between terminals at each switch position.

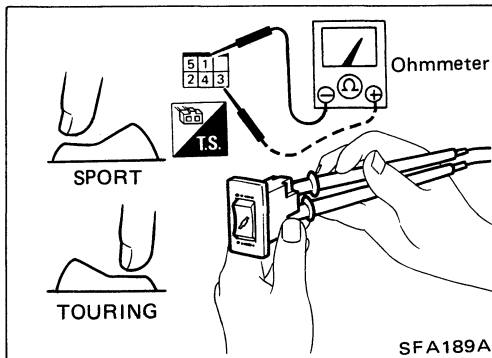

Terminal	①	②	③	④	⑤
Switch position					
NEUTRAL				Approx. 20Ω	
SPORT	○—○				
TOURING	○—○		○—○		

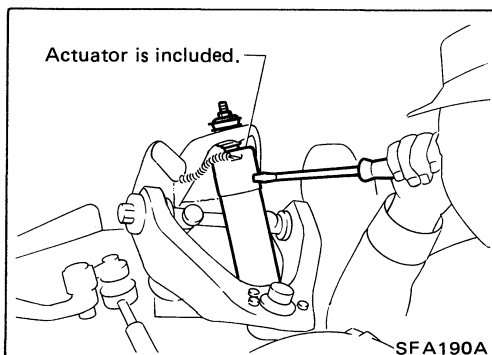

Shock Absorber Check

[Method A]

Attach a suitable tool to the shock absorber. Check operating sound of the actuator when the select switch is moved from one position (SPORT) to the other (TOURING) and vice versa.

ADJUSTABLE SHOCK ABSORBER

Shock Absorber Check (Cont'd)

[Method B]

1. Compress the shock absorber as much as possible.
2. Apply battery voltage across terminals (③ and ① , ③ and ②) of the shock absorber.
3. Check if speed varies with expansion of the shock absorber when switching to A side and B side.

If speed changes, the actuator is functioning properly. (In other words, oil passages in the shock absorber are properly switched by the actuator.)

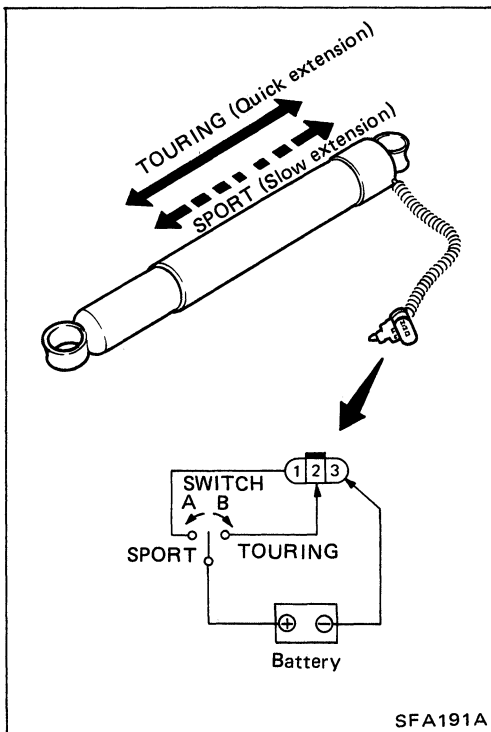

SERVICE DATA AND SPECIFICATIONS (S.D.S.)

General Specifications

TORSION BAR SPRING

Applied model	2WD		4WD
	Heavy duty and standard	Except Heavy duty and standard	
Spring diameter x Length Truck	24.4 x 885 (0.961 x 34.84)	22.6 x 885 (0.890 x 34.84)	25.0 x 1,205 (0.984 x 47.44)
Van and Wagon	24.8 x 1,230 (0.976 x 48.43)		

SHOCK ABSORBER

Applied model	Truck			Van and Wagon		
	2WD		4WD	2WD	4WD	
	Except Heavy duty and Canada	Heavy duty and Canada				
Shock absorber type	Non-adjustable			Non-adjustable	Adjustable	
Stroke mm (in)	120 (4.72)		110 (4.33)	141 (5.55)	99 (3.90)	
Damping force [At 0.3 m (1.0 ft) sec.]					TOURING	SPORT
Expansion N (kg, lb)	686 (70, 154)	1,275 (130, 287)	1,471 (150, 331) 1,961 (200, 441)*	1,471 (150, 331)	1,667 (170, 375)	2,550 (260, 573)
Compression N (kg, lb)	275 (28, 62)	392 (40, 88)	245 (25, 55) 539 (55, 121)*	588 (60, 132)	539 (55, 121)	834 (85, 187)

* : With 31 x 10.5R15 tire models

STABILIZER BAR

Model	Item	Diameter mm (in)
Truck	2WD	23 (0.91)
	4WD	20 (0.79)
Van, Wagon	4WD	23 (0.91)

TENSION ROD

Applied model	2WD
Diameter mm (in)	22 (0.87)

DRIVE SHAFT

	Wheel side	Differential carrier side
Model	ZF100	TS82F
Joint type	Rzeppa	Tripod
Maximum winding degree	46.5°	23°
Length "L" mm (in)		
Maximum	416 (16.38)	
Standard	302 (11.89)	

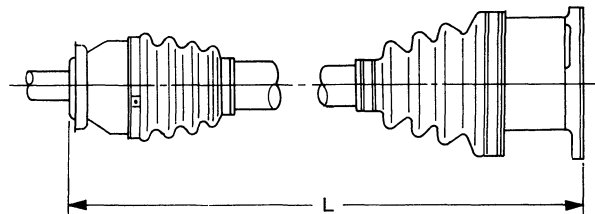

Grease Name	Nissan genuine grease or equivalent	
Capacity g (oz)	210 - 220 (7.41 - 7.76)	150 - 160 (5.29 - 5.64)

SERVICE DATA AND SPECIFICATIONS (S.D.S.)

Inspection and Adjustment

WHEEL ALIGNMENT (Unladen*1)

		B SERVICE CHECKING		B SERVICE SETTING	
		2WD	4WD	2WD	4WD
Applied model		2WD	4WD	2WD	4WD
Camber	degree	-20' to 1°10' [25'±45']	-5' to 1°25' [40'±45']	25'±30'	40'±30'
Caster	degree	-23' to 1°07' [22'±45']	33' - 2°03' [1°18'±45']	22'±30'	1°18'±30'
Kingpin inclination	degree	8°20' - 9°50' [9°05'±45']	7°21' - 8°51' [8°06'±45']	9°05'±30'	8°06'±30'
Toe-in	mm (in) (Total toe-in) degree				
Radial tire		1 - 5 (0.04 - 0.20) 7' - 27' [3±2 (0.12±0.08)] 17'±10'	2 - 6 (0.08 - 0.24) 10' - 28' [4±2 (0.16±0.08)] 19'±9' 0 - 4 (0 - 0.16)*2 0' - 19' [2±2 (0.08±0.08)] 9.5'±9.5'	3±1 (0.12±0.04) 17'±5'	4±1 (0.16±0.04) 17'±5' 2±1 (0.08±0.04)*2 10'±5'
Side to side caster difference	degree	45' or less		45' or less	
Side to side camber difference	degree	45' or less		45' or less	
Front wheel turning angle (full turn)	degree				
Inside		36° - 38°		36° - 38°	33° - 35°, 27° - 29°*3
Outside		33° - 35°		33° - 35°	31° - 33°, 25° - 27°*3
Front wheel toe-out turn	degree				
Inside		22°		22°	
Outside		20°		20°	

*1: Tankful of fuel, radiator coolant and engine oil full.
Spare tire, jack, hand tools, mats in designated positions.

*2: Van and Wagon models
*3: With 31 x 10.5R15 tire models

SERVICE DATA AND SPECIFICATIONS (S.D.S.)

Inspection and Adjustment (Cont'd)

VEHICLE POSTURE (Unladen*)

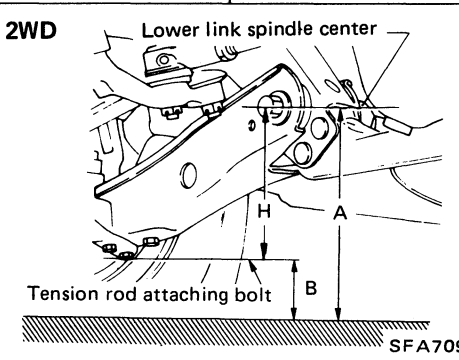
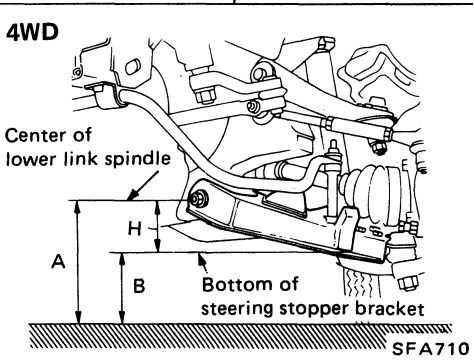
		A SERVICE CHECKING		A SERVICE SETTING	
		2WD	4WD	2WD	4WD
Applied model					
Dimension "H"	mm (in)	108 - 118 (4.25 - 4.65) [113±5 (4.45±0.20)]	41 - 51 (1.61 - 2.01) [46±5 (1.81±0.20)]	113±2 (4.45±0.08)	46±2 (1.81±0.08)
		2WD  <p>Lower link spindle center</p> <p>Tension rod attaching bolt</p> <p>SFA709</p>	4WD  <p>Center of lower link spindle</p> <p>Bottom of steering stopper bracket</p> <p>SFA710</p>		

*: Tankful of fuel, radiator coolant and engine oil full. Spare tire, jack, hand tools, mats in designated positions.

SERVICE DATA AND SPECIFICATIONS (S.D.S.)

Inspection and Adjustment (Cont'd)

WHEEL BEARING (2WD)

Wheel bearing axial end play		
mm (in)		0 (0)
Wheel bearing lock nut		
Tightening torque		34 - 39
N·m (kg-m, ft-lb)		(3.5 - 4.0, 25 - 29)
Return angle	degree	45°
Wheel bearing starting torque		
At wheel hub bolt		
With new grease seal		9.8 - 28.4
N (kg, lb)		(1.0 - 2.9, 2.2 - 6.4)
With used grease seal		9.8 - 23.5
N (kg, lb)		(1.0 - 2.4, 2.2 - 5.3)

WHEEL BEARING (4WD)

Wheel bearing lock nut		
Tightening torque		78 - 98
N·m (kg-m, ft-lb)		(8 - 10, 58 - 72)
Retightening torque after loosening wheel bearing lock nut		0.5 - 1.5
N·m (kg-m, ft-lb)		(0.05 - 0.15, 0.4 - 1.1)
Axial end play	mm (in)	0 (0)
Starting force at wheel hub bolt	N (kg, lb)	A
Turning angle	degree	15° - 30°
Starting force at wheel hub bolt	N (kg, lb)	B
Wheel bearing preload at wheel hub bolt	N (kg, lb)	7.06 - 20.99
B-A		(0.72 - 2.14, 1.59 - 4.72)

DRIVE SHAFT

Drive shaft axial end play		
mm (in)		0.1 - 0.3 (0.004 - 0.012)

Drive shaft end snap ring

Thickness mm (in)	Part No.
1.1 (0.043)	39253-31G10
1.3 (0.051)	39253-31G11
1.5 (0.059)	39253-31G12
1.7 (0.067)	39253-31G13
1.9 (0.075)	39253-31G14
2.1 (0.083)	39253-31G15
2.3 (0.091)	39253-31G16

UPPER BALL JOINT

	2WD	4WD
Turning torque "A" (Measuring point: cotter pin hole of ball stud) N (kg, lb)	31.87 - 199.38 (3.25 - 20.33, 7.17 - 44.83)	
Turning torque "B" N·m (kg-cm, in-lb)	1.0 - 4.9 (10 - 50, 8.7 - 43.4)	
Vertical end play "C" mm (in)	1.6 (0.063) or less	

LOWER BALL JOINT

	2WD	4WD
Turning torque "A" (Measuring point: cotter pin hole of ball stud) N (kg, lb)	13.63 - 54.43 (1.39 - 5.55, 3.06 - 12.24)	0 - 67.7 (0 - 6.9, 0 - 15.2)
Turning torque "B" N·m (kg-cm, in-lb)	1.0 - 3.9 (10 - 40, 8.7 - 34.7)	0 - 4.9 (0 - 50, 0 - 43)
Vertical end play "C" mm (in)	1.6 (0.063) or less	0.5 (0.020) or less

SERVICE DATA AND SPECIFICATIONS (S.D.S.)

Tightening Torque

Unit	N-m	kg-m	ft-lb
Wheel hub			
Wheel hub nut	118 - 147	12 - 15	87 - 108
Wheel hub-to-disc brake rotor	49 - 69	5 - 7	36 - 51
Knuckle arm and knuckle spindle			
Knuckle arm-to-tie rod	54 - 98	5.5 - 10.0	40 - 72
Knuckle arm-to-knuckle spindle	72 - 97	7.3 - 9.9	53 - 72
Knuckle spindle-to-caliper	72 - 97	7.3 - 9.9	53 - 72
Ball joint			
Upper ball joint-to-knuckle spindle			
2WD	78 - 147	8.0 - 15.0	58 - 108
4WD	78 - 147	8.0 - 15.0	58 - 108
Upper ball joint-to-upper link	16 - 21	1.6 - 2.1	12 - 15
Lower ball joint-to-knuckle spindle	118 - 191	12.0 - 19.5	87 - 141
Lower ball joint-to-lower link (4WD)	47 - 61	4.8 - 6.2	35 - 45
Shock absorber			
Shock absorber upper end to frame	16 - 22	1.6 - 2.2	12 - 16
Shock absorber lower end-to-lower link	59 - 78	6.0 - 8.0	43 - 58
Torsion bar spring			
Anchor adjusting bolt lock nut	30 - 40	3.1 - 4.1	22 - 30
Torque arm-to-lower link			
 Inside			
2WD	50 - 68	5.1 - 6.9	37 - 50
4WD	45 - 60	4.6 - 6.1	33 - 44
 Outside			
2WD	50 - 68	5.1 - 6.9	37 - 50
4WD	89 - 118	9.1 - 12.0	66 - 87
Bound bumper			
Bound bumper-to-frame			
2WD	8 - 11	0.8 - 1.1	5.8 - 8.0
Bound bumper-to-lower link			
4WD	16 - 22	1.6 - 2.2	12 - 16

Unit	N-m	kg-m	ft-lb
Upper link			
Upper link spindle-to-upper link	71 - 103	7.2 - 10.5	52 - 76
Upper link spindle-to-frame	109 - 147	11.1 - 15.0	80 - 108
Lower link			
Lower link-to-frame	109 - 147	11.1 - 15.0	80 - 108
Tension rod			
Tension rod-to-lower link	49 - 64	5.0 - 6.5	36 - 47
Tension rod-to-frame	118 - 157	12.0 - 16.0	87 - 116
Stabilizer bar			
Stabilizer bar-to-frame	16 - 22	1.6 - 2.2	12 - 16
Stabilizer bar-to-lower link	16 - 22	1.6 - 2.2	12 - 16
Steering stopper bolt			
Steering stopper bolt lock nut			
2WD	26 - 36	2.7 - 3.7	20 - 27
4WD	76 - 98	7.8 - 10	56 - 72
Compression rod 4WD			
Compression rod-to-lower link	118 - 147	12.0 - 15.0	87 - 108
Compression rod-to-body	118 - 157	12.0 - 16.0	87 - 116
Drive shaft 4WD			
Drive shaft-to-differential carrier	34 - 44	3.5 - 4.5	25 - 33
Free-running hub 4WD			
Manual-lock			
Free-running hub-to-wheel hub	25 - 34	2.5 - 3.5	18 - 25
Auto-lock			
Free running hub-to-wheel hub	25 - 34	2.5 - 3.5	18 - 25

REAR AXLE & REAR SUSPENSION

SECTION **RA**

CONTENTS

PRECAUTIONS AND PREPARATION	RA- 2
REAR AXLE AND REAR SUSPENSION	RA- 4
CHECK AND ADJUSTMENT – On-vehicle	RA- 6
REAR AXLE – Single-tire Models	RA- 7
REAR SUSPENSION – Leaf Spring Type	RA-12
REAR AXLE AND REAR SUSPENSION – 5-link Type	RA-17
REAR SUSPENSION – 5-link Type	RA-18
SERVICE DATA AND SPECIFICATIONS (S.D.S.)	RA-21

* For adjustable shock absorber, refer to FA section.

RA

PRECAUTIONS AND PREPARATION

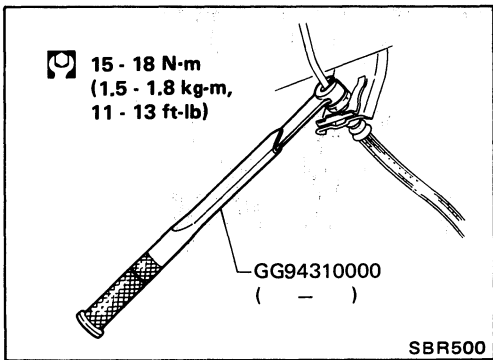



Precautions

- (1) When installing each rubber part, final tightening must be carried out under unladen condition* with tires on ground.
 - * Fuel, radiator coolant and engine oil full. Spare tire, jack, hand tools and mats in designated positions.
- (2) Use Tool when removing or installing brake tubes.

Preparation

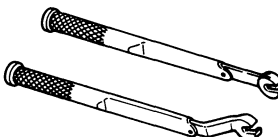
SPECIAL SERVICE TOOLS

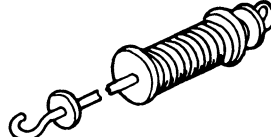
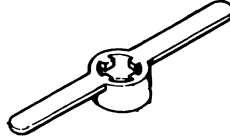
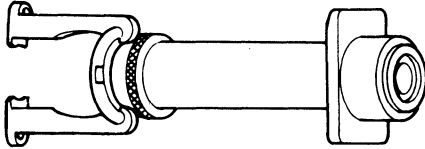
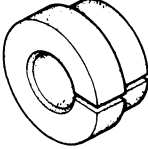
Tool number (Kent-Moore No.) Tool name	Description
GG94310000 (-) Flare nut torque wrench	 <p>Removing or installing brake piping</p>
KV40101000 (J25604-01) Axle stand	 <p>Removing rear axle shaft</p>
ST36230000 (J25840-A) Sliding hammer	 <p>Removing rear axle shaft</p>
ST38020000 (-) Bearing lock nut wrench	 <p>Removing wheel bearing lock nut</p>
HT72480000 (J25852-B) Rear axle shaft bearing puller	 <p>Removing wheel bearing</p>
ST37840000 (-) Rear axle shaft guide	 <p>Installing rear axle shaft</p>

PRECAUTIONS AND PREPARATION

Preparation (Cont'd)

COMMERCIAL SERVICE TOOLS

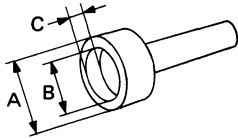
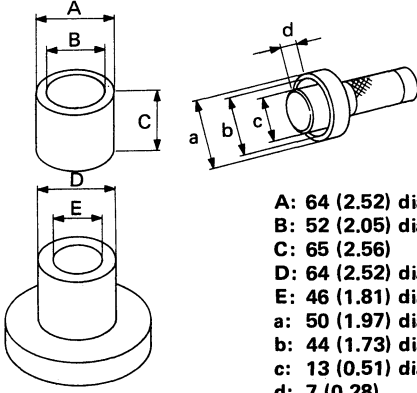
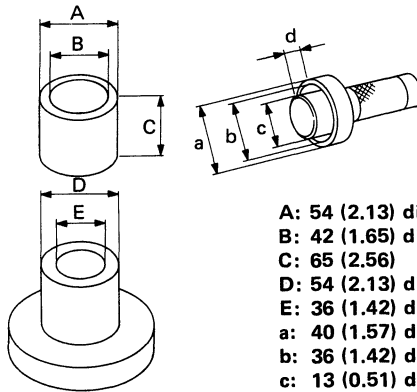
Tool name	Description	Unit application		
		Leaf	5-link	
Rear axle oil seal drift	 <p style="margin-left: 40px;"> A: 74 mm (2.91 in) dia. B: 68 mm (2.68 in) dia. C: 10 mm (0.39 in) </p>	Installing oil seal	X	X
Drift-lower and upper links bushing	 <p style="margin-left: 40px;"> A: 64 (2.52) dia. B: 52 (2.05) dia. C: 65 (2.56) D: 64 (2.52) dia. E: 46 (1.81) dia. a: 50 (1.97) dia. b: 44 (1.73) dia. c: 13 (0.51) dia. d: 7 (0.28) </p> <p style="margin-left: 40px;">Unit: mm (in)</p>	Removing or installing lower and upper links bushing	-	X
Drift-panhard rod bushing	 <p style="margin-left: 40px;"> A: 54 (2.13) dia. B: 42 (1.65) dia. C: 65 (2.56) D: 54 (2.13) dia. E: 36 (1.42) dia. a: 40 (1.57) dia. b: 36 (1.42) dia. c: 13 (0.51) dia. d: 6 (0.24) </p> <p style="margin-left: 40px;">Unit: mm (in)</p>	Removing or installing panhard rod bushing	-	X

REAR AXLE AND REAR SUSPENSION

2WD MODELS

Single-tire models

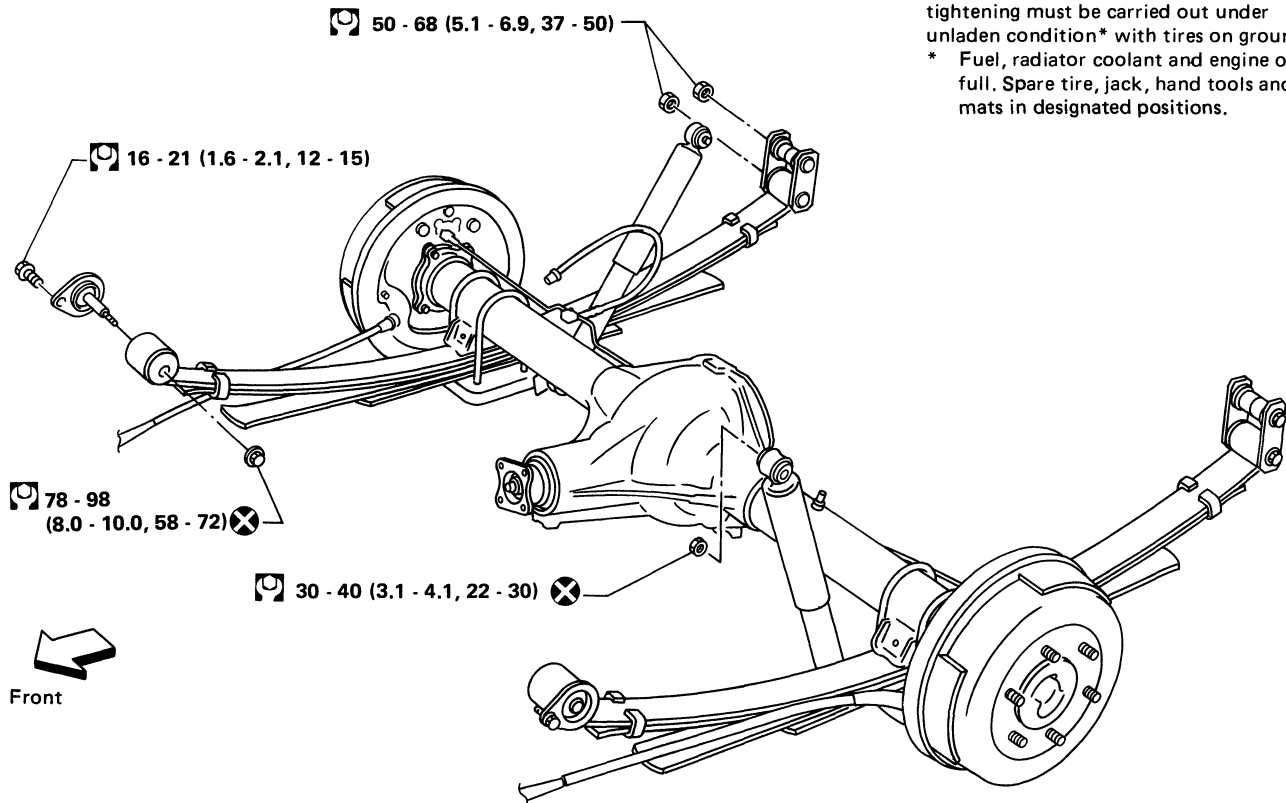

When installing each rubber part, final tightening must be carried out under unladen condition* with tires on ground.
* Fuel, radiator coolant and engine oil full. Spare tire, jack, hand tools and mats in designated positions.

 : N·m (kg·m, ft·lb)

SRA732

REAR AXLE AND REAR SUSPENSION

4WD MODELS

Except Van and Wagon models

When installing each rubber part, final tightening must be carried out under unladen condition* with tires on ground.
 * Fuel, radiator coolant and engine oil full. Spare tire, jack, hand tools and mats in designated positions.

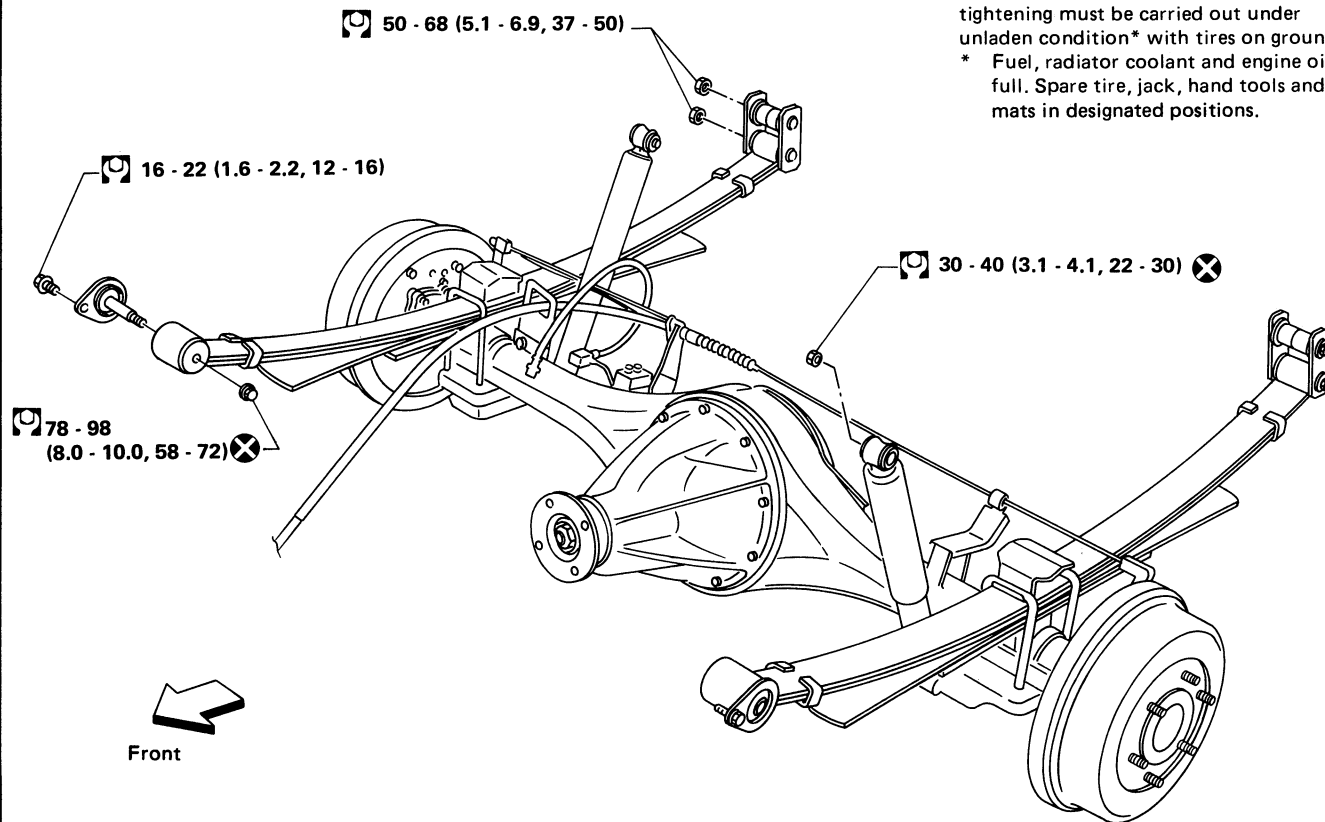

SRA733

Van and Wagon models

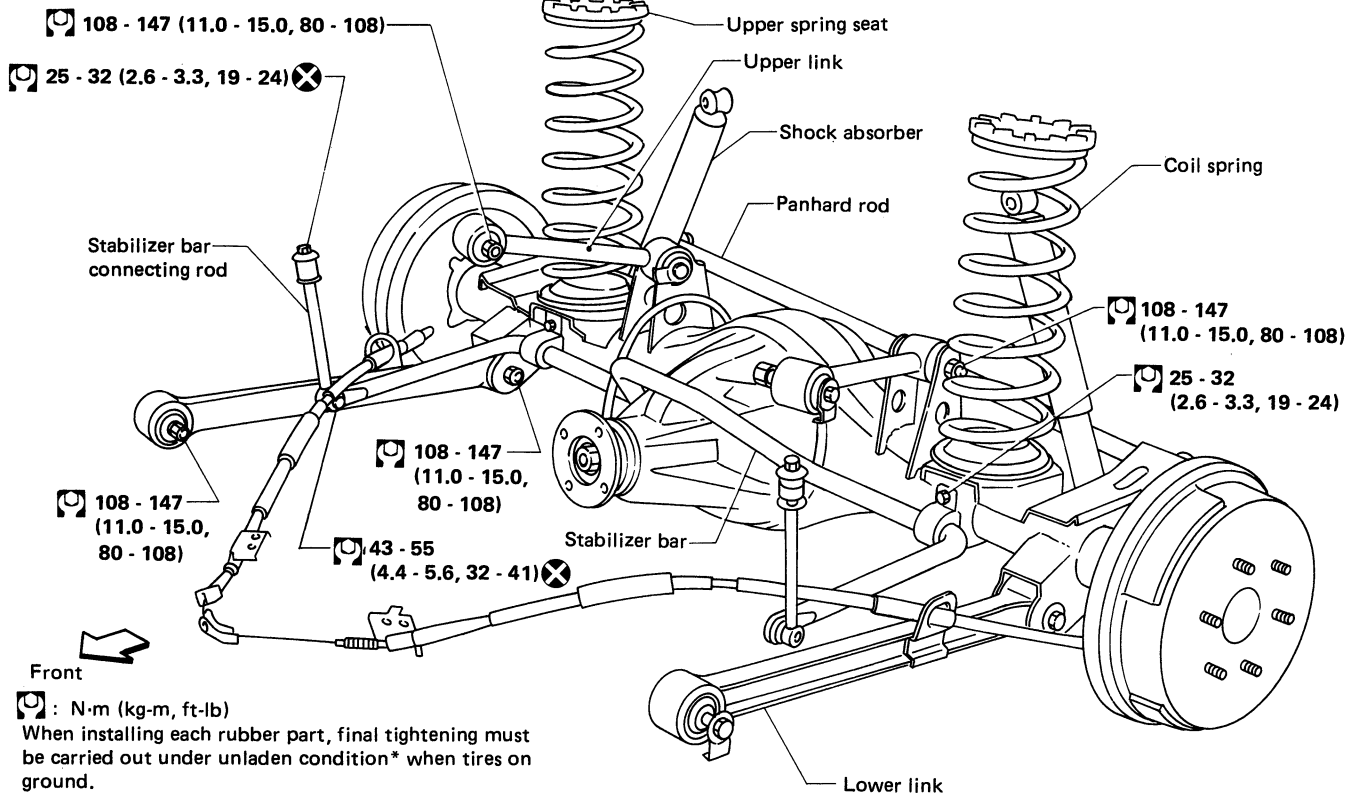

SRA905

CHECK AND ADJUSTMENT — On-vehicle

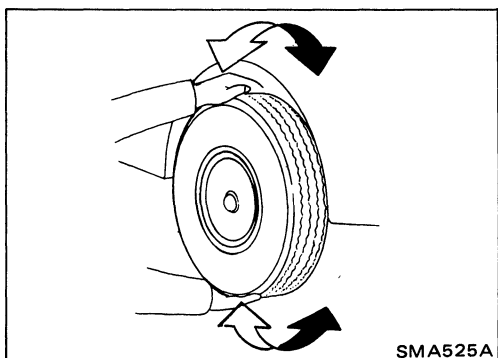

Rear Axle and Rear Suspension Parts

- Check rear axle and rear suspension parts for looseness, wear or damage.

(1) Shake each rear wheel.

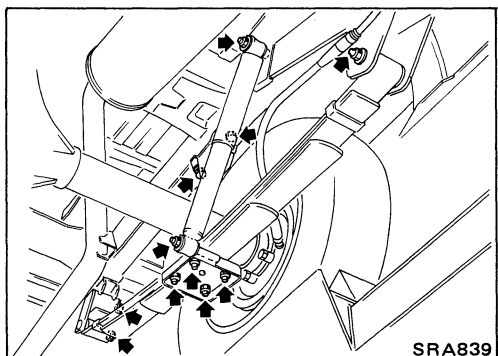

(2) Retighten all nuts and bolts to the specified torque.

Tightening torque: Refer to S.D.S.

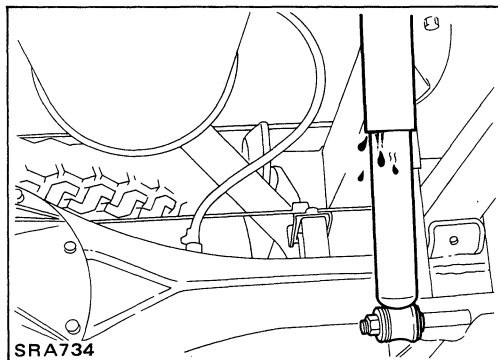

- Check shock absorber for oil leakage or other damage.

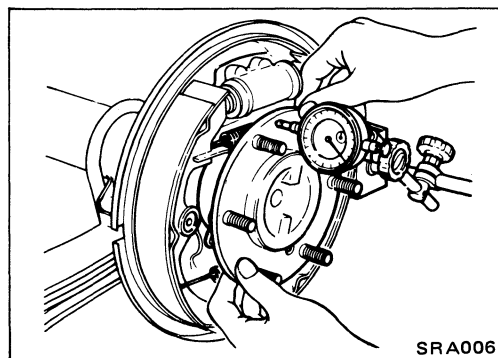

Rear Wheel Bearing

SINGLE-TIRE MODELS

- Check that wheel bearings operate smoothly.
- Check axial end play. Refer to Installation of REAR AXLE — Single-tire Models.

REAR AXLE — Single-tire Models

Components

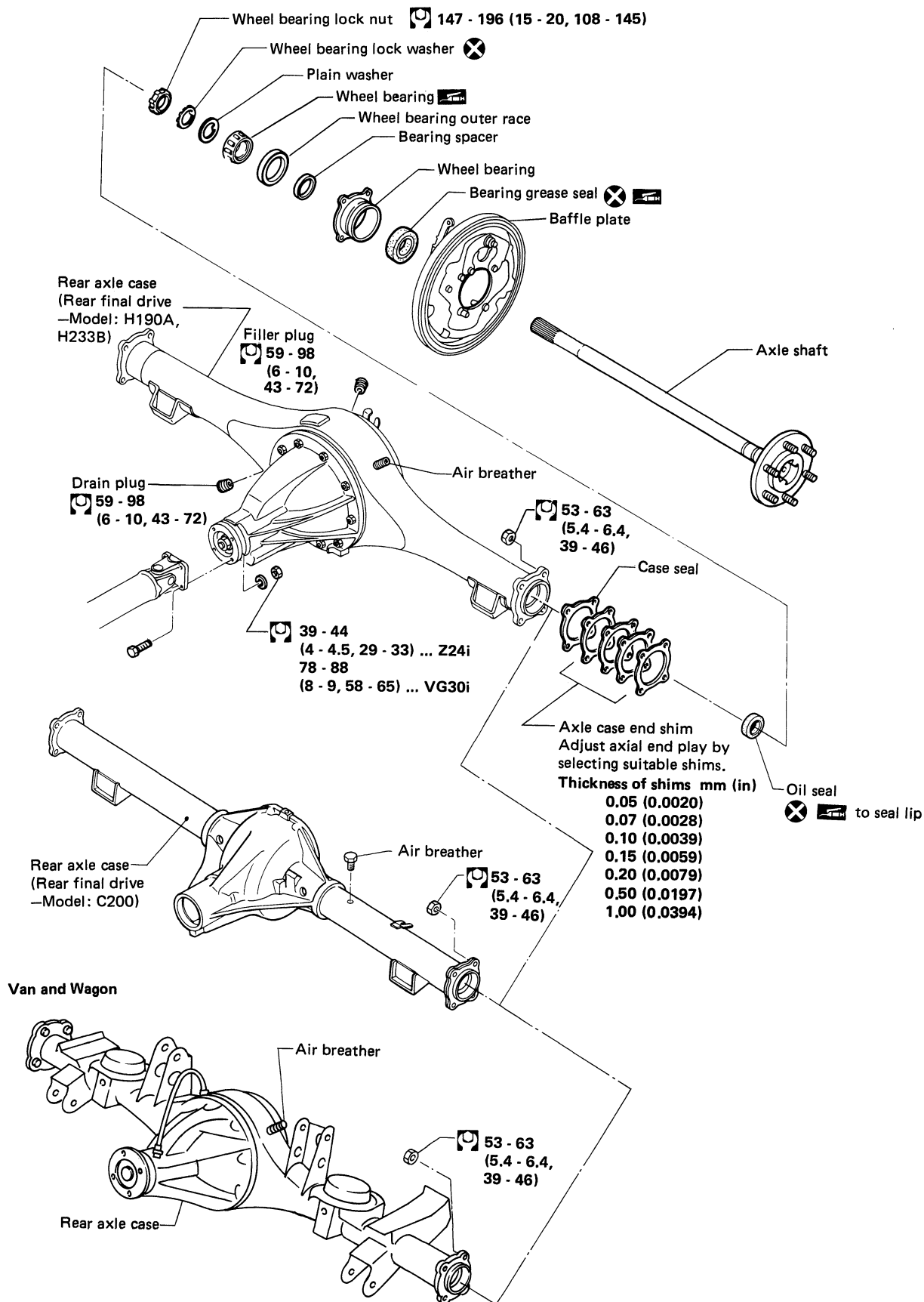

: N·m (kg·m, ft·lb)

SRA934

REAR AXLE — Single-tire Models

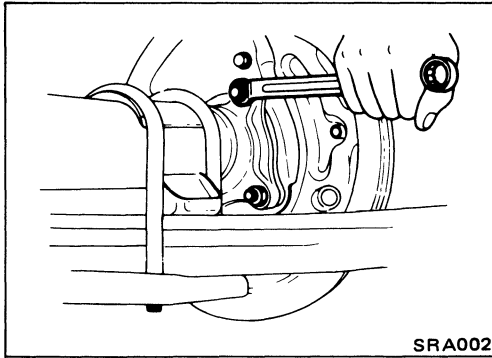

Removal

- Disconnect parking brake cable and brake tube.
- Remove nuts securing wheel bearing cage with baffle plate.

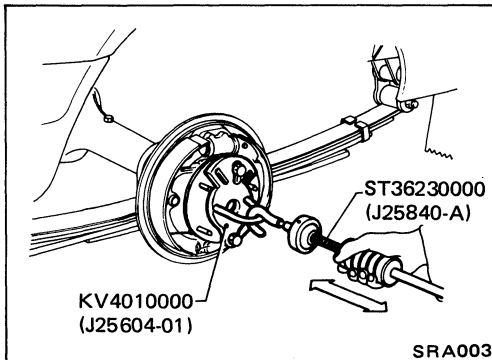

- Draw out axle shaft with Tool.
When drawing out axle shaft, be careful not to damage oil seal.

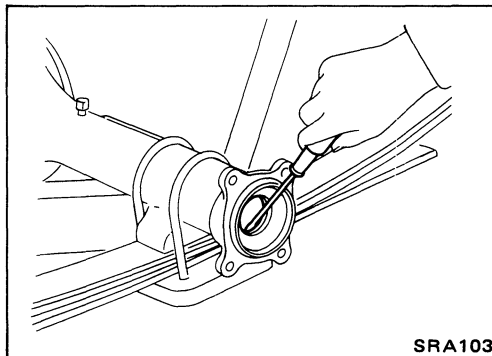

- Remove oil seal.
Do not reuse oil seal once it is removed.
Always install new one.

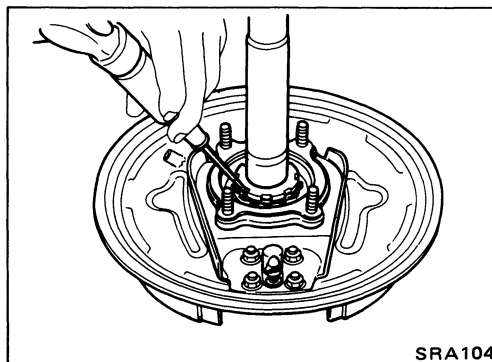

- Unbend lock washer with a screwdriver.

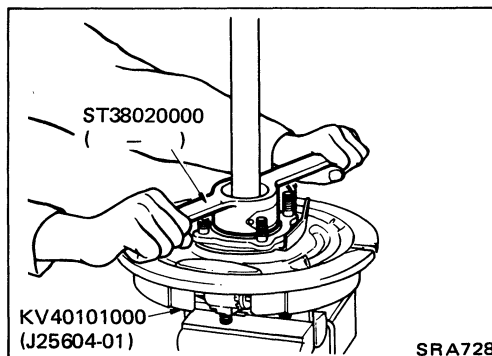

- Remove bearing lock nut with Tool.

REAR AXLE — Single-tire Models

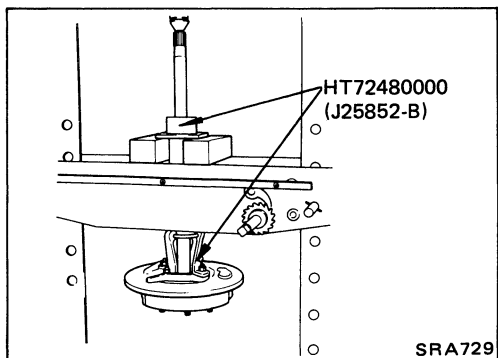

Removal (Cont'd)

- Remove wheel bearing together with bearing cage and baffle plate from axle shaft.

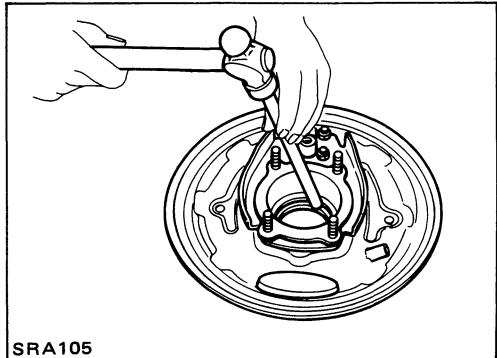

- Remove grease seal in bearing cage with suitable bar.

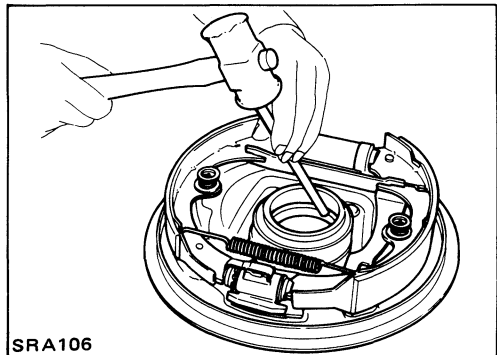

- Remove wheel bearing outer race with a brass drift.

Inspection

AXLE SHAFT

- Check axle shaft for straightness, cracks, damage, wear or distortion. Replace if necessary.

WHEEL BEARING

- Make sure wheel bearing rolls freely and is free from noise, cracks, pitting or wear.

AXLE CASE

- Check axle case for yield, deformation or cracks. Replace if necessary.

REAR AXLE — Single-tire Models

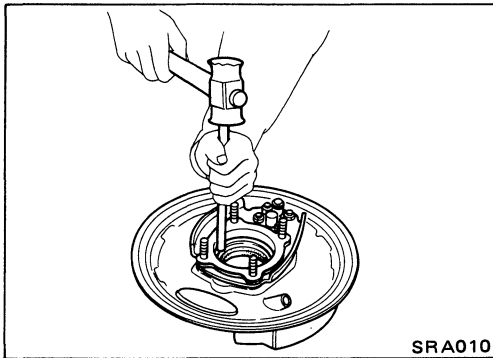

Installation

- Install wheel bearing outer race with a brass drift.
 - Install a new grease seal in bearing cage.
- After installing new grease seal, coat sealing lip with multi-purpose grease.

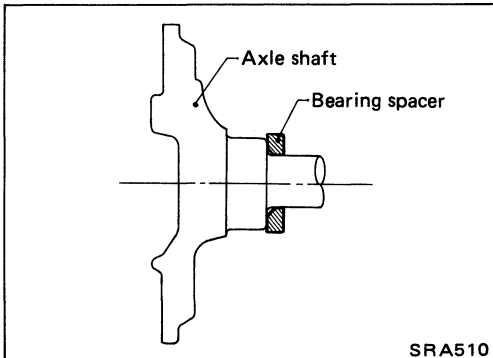

- Install bearing spacer with chamfer side facing axle shaft flange.

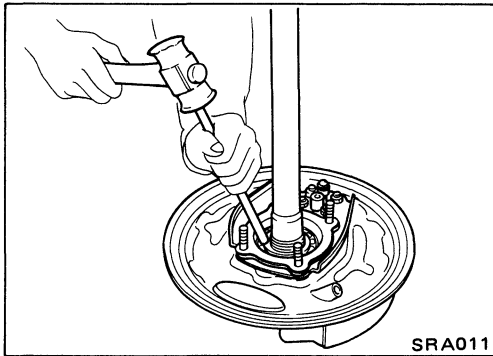

- Install wheel bearing inner race with a brass drift.
- Coat each bearing cone with multi-purpose grease.

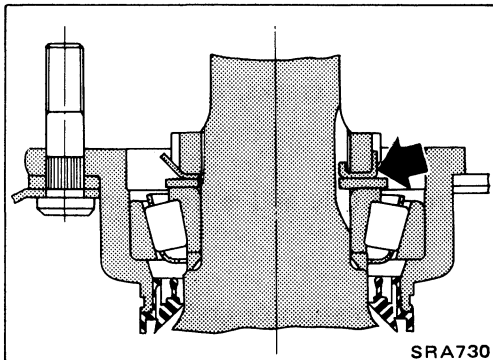

- Install plain washer and a new wheel bearing lock washer.
 - Tighten wheel bearing lock nut.
- Fit wheel bearing lock washer lip in wheel bearing lock nut groove correctly by tightening lock nut. Be sure to bend it up.

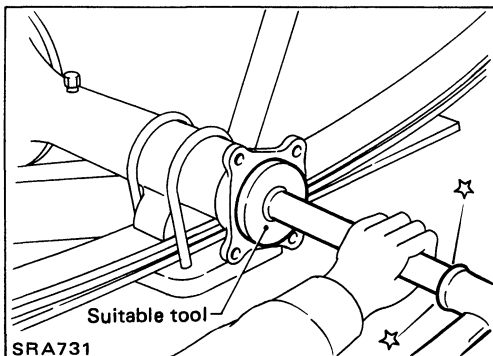

- Install a new oil seal with suitable tool.
- After installing new oil seal, coat sealing lip with multi-purpose grease.

REAR AXLE — Single-tire Models

Installation (Cont'd)

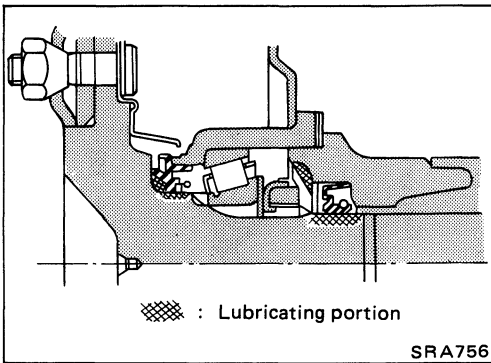

- Apply recess of axle case end with multi-purpose grease.
- Apply gear oil to the spline of axle shaft. Coat seal surface of axle shaft with multi-purpose grease (as shown left).

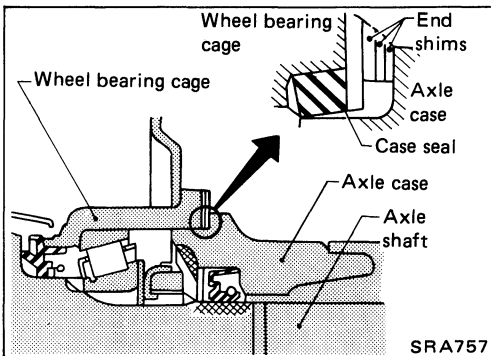

- Adjust axial end play.

(1) Select end shims.

Standard thickness: 1.5 mm (0.059 in)

Axle case end shim: Refer to S.D.S.

Do not insert end shims between case seal and bearing cage.

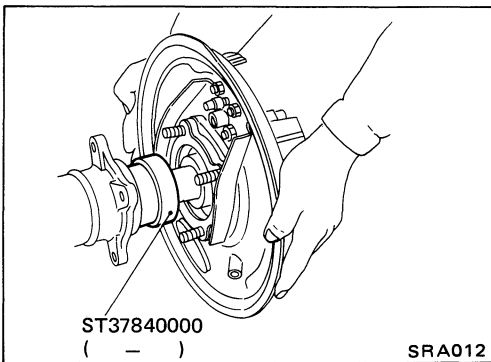

(2) Insert axle shaft with Tool as a guide.

When inserting axle shaft, be careful not to damage oil seal.

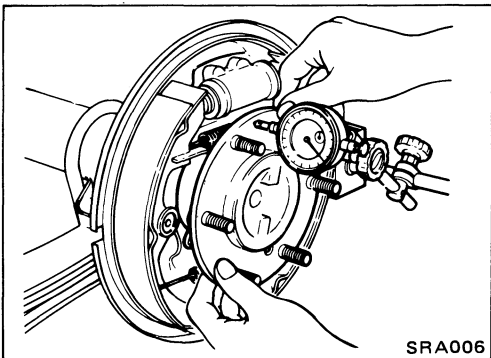

(3) Measure end play of axle shaft.

Axial end play:

 Servicing one side axle

 0.02 - 0.15 mm (0.0008 - 0.0059 in)

 Servicing both side axles

 On first axle (right or left)

 0.30 - 0.90 mm (0.0118 - 0.0354 in)

 On second axle

 0.02 - 0.15 mm (0.0008 - 0.0059 in)

(4) If axial end play is not within the specified limit, reselect axle case end shims.

While adjusting axial end play, be careful not to damage oil seal.

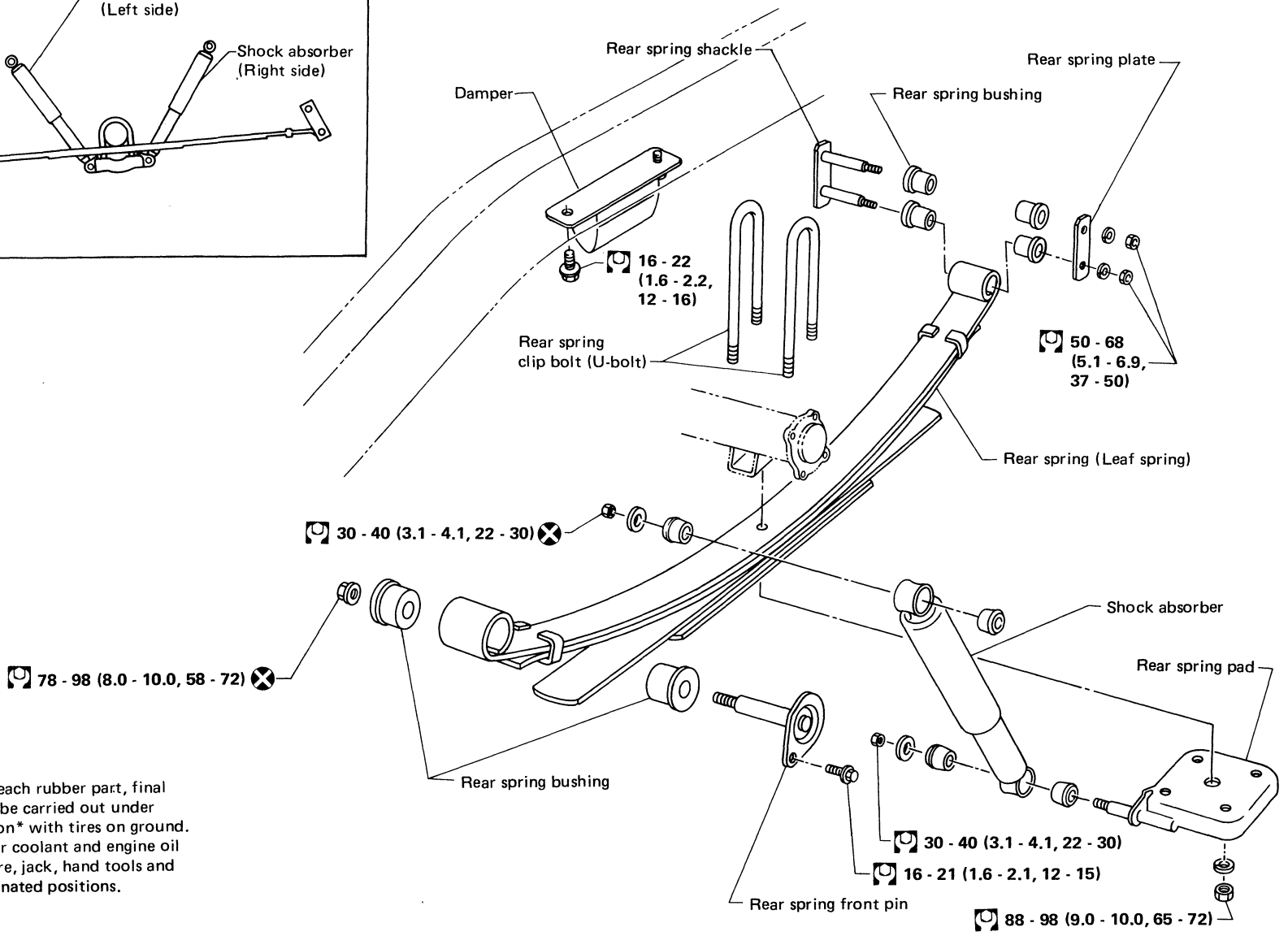
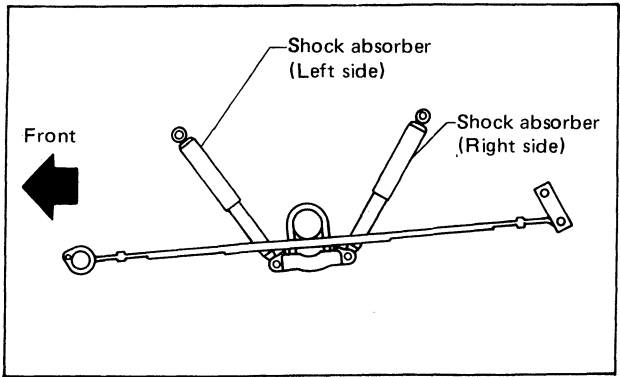

When installing each rubber part, final tightening must be carried out under unladen condition* with tires on ground.
 * Fuel, radiator coolant and engine oil full. Spare tire, jack, hand tools and mats in designated positions.

: N·m (kg·m, ft·lb)

RA-13

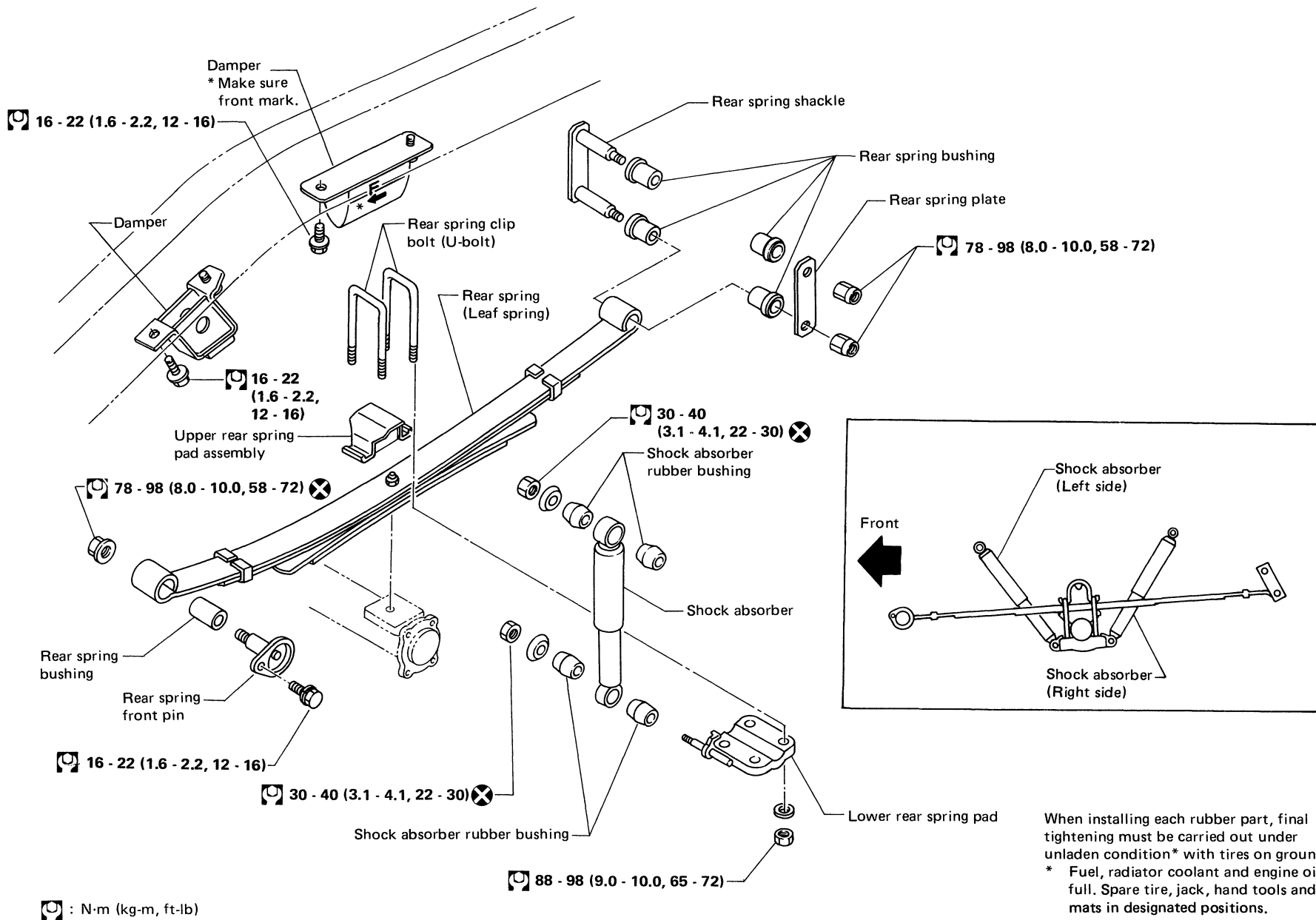

When installing each rubber part, final tightening must be carried out under unladen condition* with tires on ground.
 * Fuel, radiator coolant and engine oil full. Spare tire, jack, hand tools and mats in designated positions.

REAR SUSPENSION — Leaf Spring Type

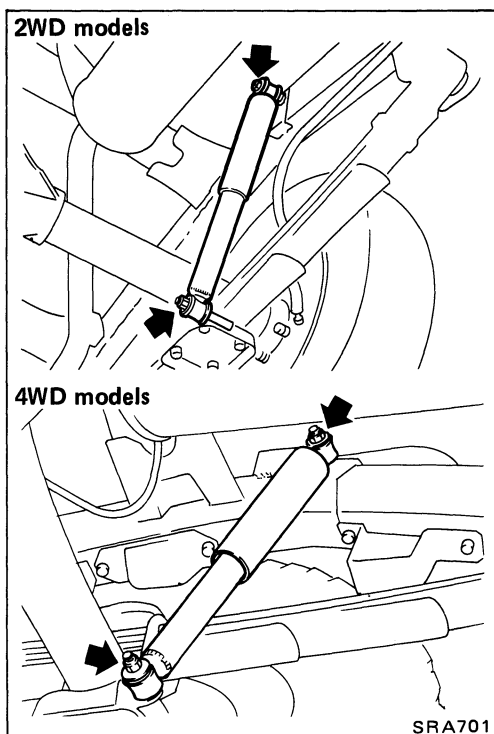

Shock Absorber REMOVAL AND INSTALLATION

- Remove shock absorber by disconnecting upper and lower end.

INSPECTION

- If oil leakage, cracks or deformation occurs, replace shock absorber assembly.
- If rubber bushings are cracked or deformed, replace rubber bushings.

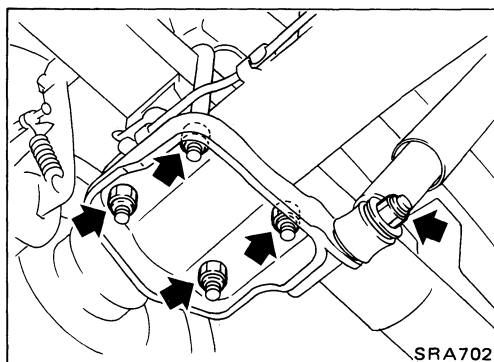

Leaf Spring REMOVAL AND INSTALLATION

- Disconnect shock absorber lower end, and remove U-bolts.

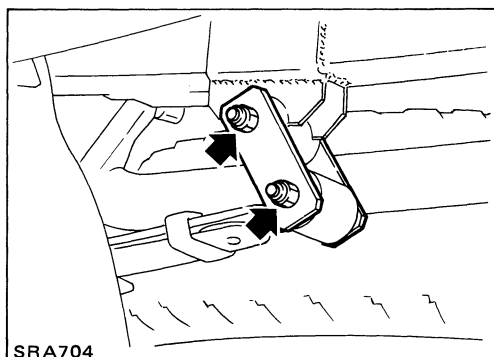

- Disconnect spring shackle.

REAR SUSPENSION — Leaf Spring Type

Leaf Spring (Cont'd)

- Disconnect front pin.

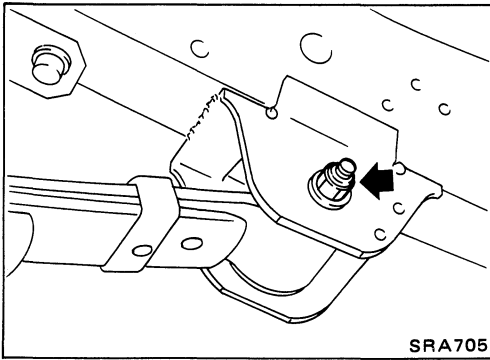

INSPECTION

- Check leaf spring for cracks. Replace if necessary.
- Check front bracket and pin, shackle, U-bolts and spring pad for wear, cracks, straightness or damaged threads. Replace if necessary.

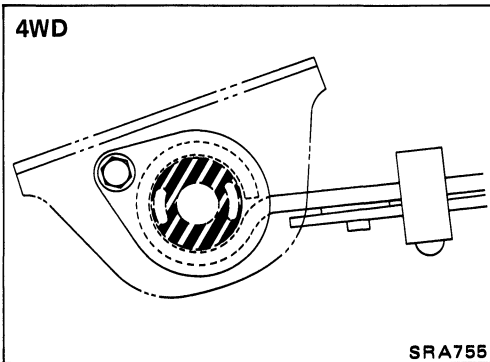

- Check all bushings for deformation or cracks. Replace if necessary.

[4WD: Rear spring front bushing]

Make sure that front bushing is properly installed.

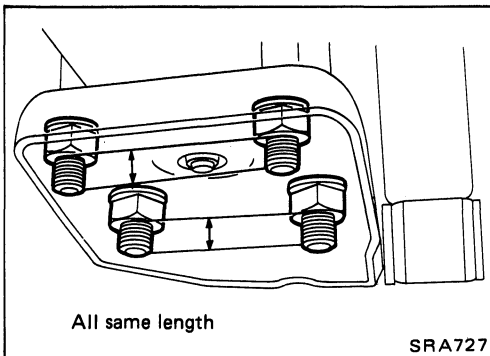

INSTALLATION

- Apply soapsuds to rubber bushing.
- Install spring shackle and front pin, and finger tighten the nuts.
- Install spring pad and nuts under rear spring or axle case.
- Tighten U-bolt mounting nuts diagonally.

Tighten U-bolts so that the length of all U-bolts under spring pad are the same.

- Install shock absorber, and finger tighten the nuts.

- Remove stands and bounce the vehicle to stabilize suspension. (Unladen)

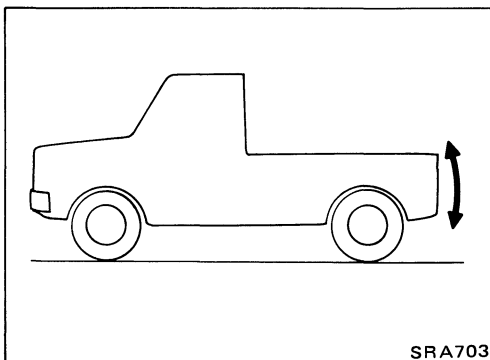

REAR SUSPENSION — Leaf Spring Type

Leaf Spring (Cont'd)

- Tighten spring shackle nuts, front pin nuts and shock absorber nuts.

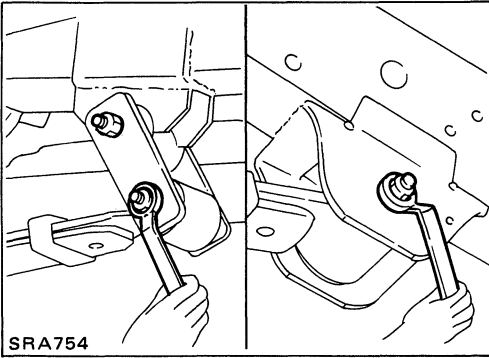

REAR AXLE AND REAR SUSPENSION — 5-link Type

Removal and Installation

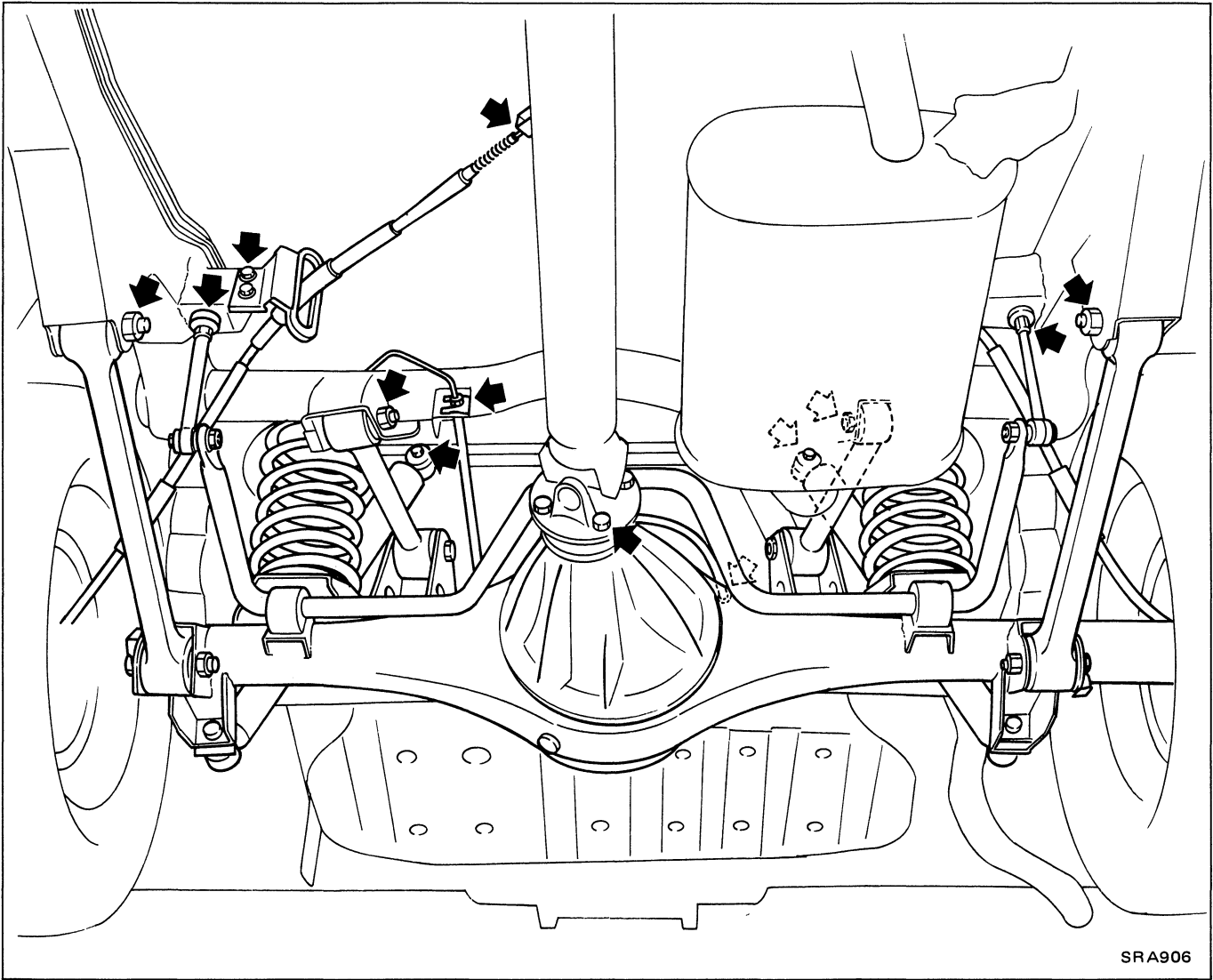

SRA906

 15 - 18 N·m
(1.5 - 1.8 kg·m,
11 - 13 ft·lb)

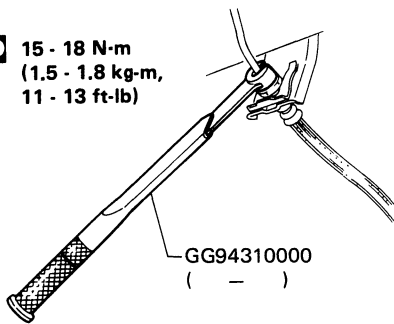

SBR500

- Disconnect brake hydraulic line and parking brake cable.

CAUTION:

Use Tool when removing or installing brake tubes.

- Remove stabilizer bar from body.
- Remove upper links and lower links from body.
- Remove panhard rod from body.
- Disconnect propeller shaft. Refer to section PD.
- Remove upper end nuts of shock absorber.

Final tightening for rubber parts requires to be carried out under unladen condition with tires on ground.

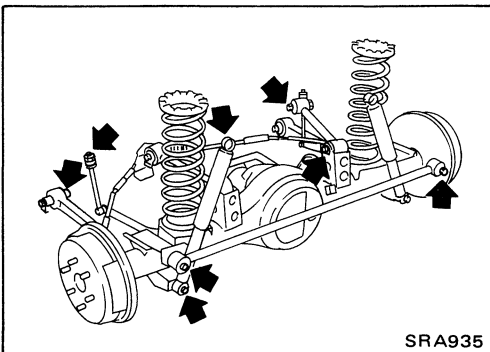

SRA935

RA-18

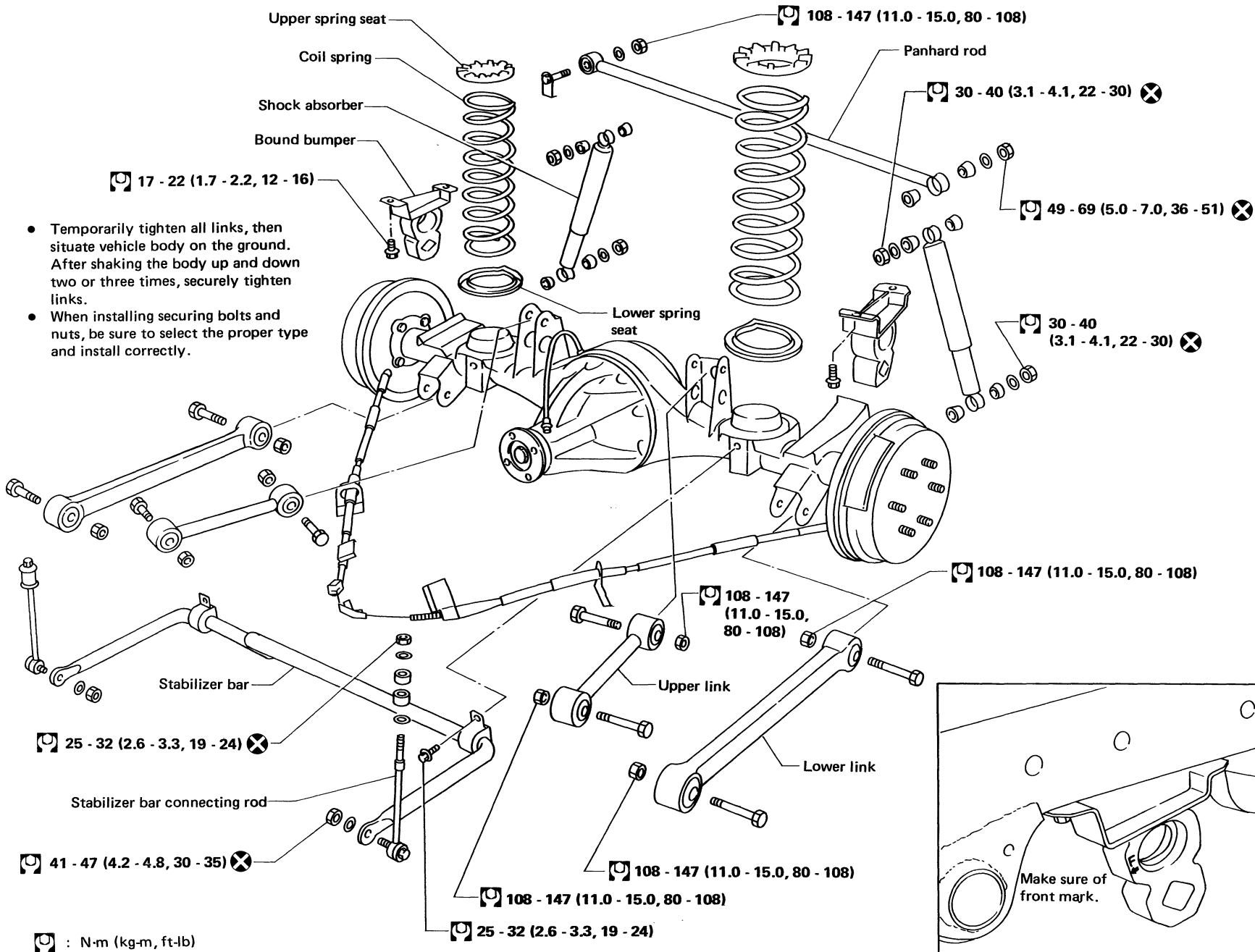

- Temporarily tighten all links, then situate vehicle body on the ground. After shaking the body up and down two or three times, securely tighten links.
- When installing securing bolts and nuts, be sure to select the proper type and install correctly.

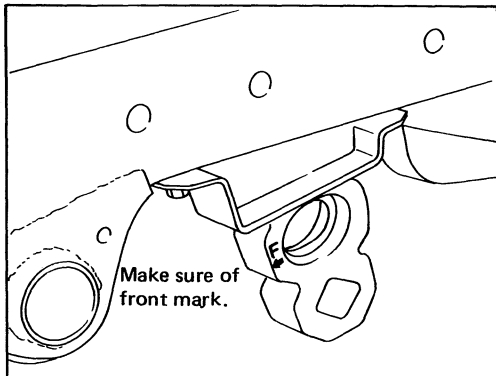

⊗ : N·m (kg·m, ft·lb)

SRA092A

REAR SUSPENSION — 5-link Type

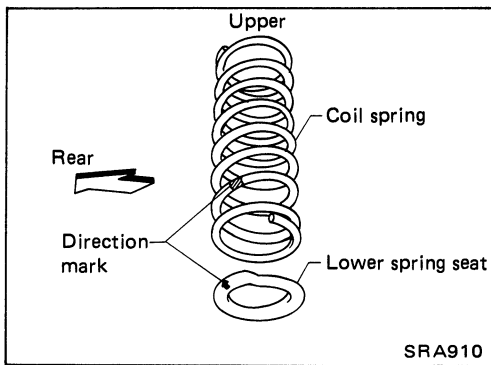

Coil Spring and Shock Absorber

REMOVAL AND INSTALLATION

- Refer to Removal and Installation of REAR AXLE AND REAR SUSPENSION — 5-link Type.

When installing coil spring and lower spring seat, pay attention to its direction.

Be sure spring rubber seat is not twisted and has not slipped off when installing coil spring.

INSPECTION

- Check coil spring for yield, deformation or cracks.
- Check coil spring specifications. Refer to S.D.S.
- Check shock absorber for oil leakage, cracks or deformation.
- Check shock absorber specifications. Refer to S.D.S.
- Check all rubber parts for wear, cracks or deformation. Replace if necessary.

Upper Link, Lower Link and Panhard Rod

INSPECTION

Check for cracks, distortion or other damage. Replace if necessary.

BUSHING REPLACEMENT

Check for cracks or other damage. Replace with suitable tool if necessary.

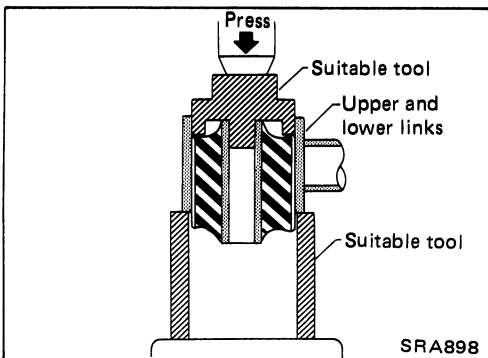

Upper and lower links bushing

- Remove upper and lower links bushing with suitable tool.

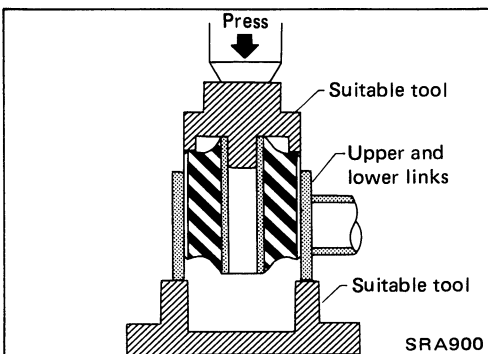

When installing upper and lower links bushing, apply a coating of 1% soap water to outer wall of bushing.

Always install new bushing.

Do not tap end face of bushing directly with a hammer.

REAR SUSPENSION — 5-link Type

Upper Link, Lower Link and Panhard Rod (Cont'd)

Panhard rod bushing

- Remove panhard rod bushing with suitable tool.

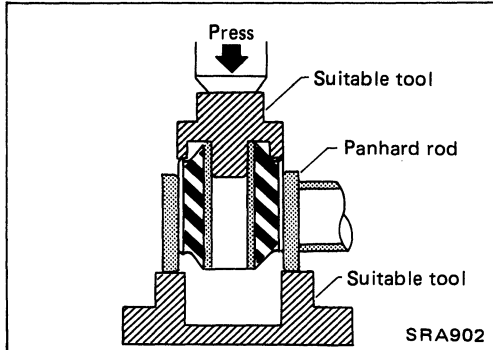
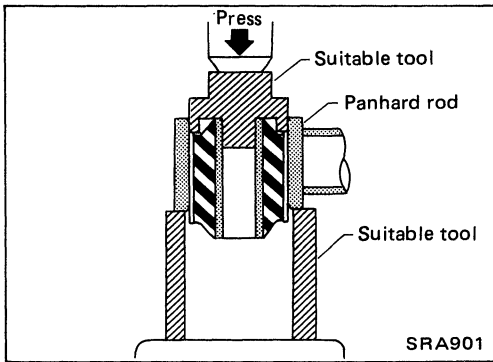

When installing panhard rod bushing, apply a coating of 1% soap water to outer wall of bushing.

Always install new bushing.

Do not tap end face of bushing directly with a hammer.

INSTALLATION

When installing each link, pay attention to direction of bolts and nuts.

When installing each rubber part, final tightening must be carried out under unladen condition with tires on ground.

Stabilizer Bar

REMOVAL AND INSTALLATION

- When removing and installing stabilizer bar, fix portion A.

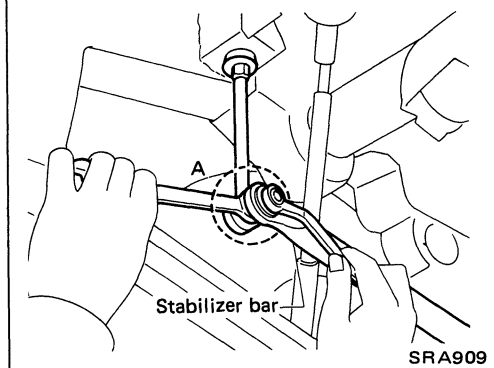
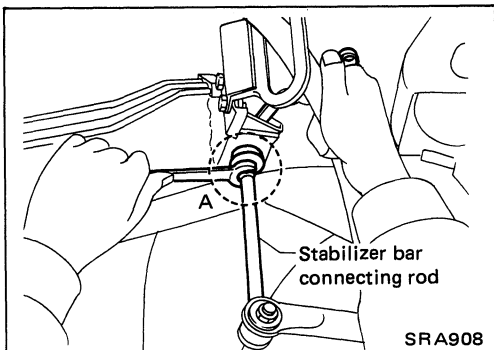

LEAF SPRING

Model	2WD				4WD		
	U.S.A.	Canada	Regular Cab*	Heavy duty			
Suspension type	Semi-elliptic leaf spring						
Leaf spring	Length x width x thickness - number of leaves mm (in)	1,200 x 60 x 7 - 2 13 - 1 (47.24 x 2.36 x 0.28 - 2) 0.51 - 1	1,200 x 60 x 7 - 2 12 - 2 (47.24 x 2.36 x 0.28 - 2) 0.47 - 2	1,200 x 60 x 7 - 2 13 - 1 (47.24 x 2.36 x 0.28 - 2) 0.51 - 1	1,200 x 60 x 8 - 2 14 - 2 (47.24 x 2.36 x 0.31 - 2) 0.55 - 2	1,200 x 60 x 7 - 1 8 - 1 12 - 1 13 - 1 (47.24 x 2.36 x 0.28 - 1) 0.31 - 1 0.47 - 1 0.51 - 1	
	Free camber "S" mm (in)	171 (6.73)	164.5 (6.48)	171 (6.73)	134.5 (5.30)	106 (4.17)	
	Spring constant N/mm (kg/mm, lb/in)	20.9 - 58.0 (2.13 - 5.91, 119.3 - 331.0)	22.3 - 76.5 (2.27 - 7.8, 127.1 - 436.8)	20.9 - 58.0 (2.13 - 5.91, 119.3 - 331.0)	32.6 - 114.7 (3.32 - 11.7, 185.9 - 655.2)	24.1 - 90.2 (2.46 - 9.2, 137.8 - 515.2)	
Shock absorber	Maximum length "L" mm (in)	508 (20.00)				528 (20.79)	
	Stroke mm (in)	200 (7.87)				210 (8.27)	
	Damping force [0.3 m/sec. (1.0 ft/sec.)] N (kg, lb) Expansion	785 (80, 176)			981 (100, 221)	Except Canada 785 (80, 176)	Canada 1,716 (175, 386)
		216 (22, 49)			216 (22, 49)	216 (22, 49)	343 (35, 77)



SRA111

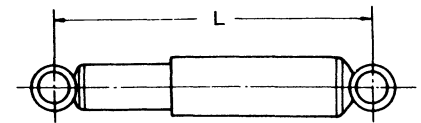

RA260

*: 4-speed M/T models only

RA-21

General Specifications (Leaf spring type)

SERVICE DATA AND SPECIFICATIONS (S.D.S.)

SERVICE DATA AND SPECIFICATIONS (S.D.S.)

General Specifications (5-link type)

SHOCK ABSORBER

Suspension type	5-link		
Shock absorber type	Non-adjustable	Adjustable	
Stroke mm (in)	234 (9.21)	211 (8.31)	
Maximum length "L" mm (in)	586 (23.07)	585 (23.03)	
Damping force at 0.3 m (1.0 ft)/sec.	785 (80, 176)	TOURING	SPORT
		628 (64, 141)	1,491 (152, 335)
Expansion N (kg, lb)			
Compression N (kg, lb)	343 (35, 77)	382 (39, 86)	667 (68, 150)

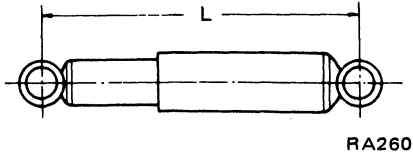

COIL SPRING

Suspension type	5-link	
Wire diameter mm (in)	13.2 (0.520)	
Coil diameter mm (in)	117.2 (4.61)	
Free length mm (in)	417 (16.42)	
Spring constant N/mm (kg/mm, lb/in)	25.5 (2.6, 146)	
Identification color	White x 1, Blue x 1	

Inspection and Adjustment

SINGLE-TIRE

Unit: mm (in)

Total end play	0.02 - 0.15 (0.0008 - 0.0059)	
	Thickness	Part No.
Rear axle case end shim	0.05 (0.0020)	43086 P0110
	0.07 (0.0028)	43087 P0110
	0.10 (0.0039)	43088 P0110
	0.15 (0.0059)	43086 B9500
	0.20 (0.0079)	43089 P0110
	0.50 (0.0197)	43090 P0110
	1.00 (0.0394)	43036 01G00

SERVICE DATA AND SPECIFICATIONS (S.D.S.)

Tightening Torque

Unit	N-m	kg-m	ft-lb
Drain plug	59 - 98	6 - 10	43 - 72
Filler plug			
H190A	59 - 98	6 - 10	43 - 72
H233B	59 - 98	6 - 10	43 - 72
C200	39 - 59	4 - 6	29 - 43
Back plate fixing bolt	53 - 63	5.4 - 6.4	39 - 46
Wheel bearing lock nut	147 - 196	15 - 20	108 - 145
Wheel cylinder air breather	7 - 9	0.7 - 0.9	5.1 - 6.5
Differential gear carrier to axle case nut			
H190A	16 - 24	1.6 - 2.4	12 - 17
C200	11 - 14	1.1 - 1.4	8 - 10
H233B	27 - 36	2.8 - 3.7	20 - 27
Wheel nut			
Aluminum wheel	118 - 147	12 - 15	87 - 108
Steel wheel	118 - 147	12 - 15	87 - 108
Brake tube flare nut	15 - 18	1.5 - 1.8	11 - 13
Propeller shaft to companion flange			
Z24i engine	39 - 44	4 - 4.5	29 - 33
VG30i engine	78 - 88	8 - 9	58 - 65

5-link type

Unit	N-m	kg-m	ft-lb
Shock absorber upper end fixing nut	30 - 40	3.1 - 4.1	22 - 30
Shock absorber lower end fixing nut	30 - 40	3.1 - 4.1	22 - 30
Bumper rubber fixing bolt	17 - 22	1.7 - 2.2	12 - 16
Upper link fixing bolt	108 - 147	11.0 - 15.0	80 - 108
Lower link fixing bolt	108 - 147	11.0 - 15.0	80 - 108
Panhard rod fixing bolt (R.H. side)	108 - 147	11.0 - 15.0	80 - 108
Panhard rod fixing nut (L.H. side)	49 - 69	5.0 - 7.0	36 - 51
Stabilizer bar to connecting rod	41 - 47	4.2 - 4.8	30 - 35
Connecting rod to body	25 - 32	2.6 - 3.3	19 - 24
Stabilizer bar bracket to axle case	25 - 32	2.6 - 3.3	19 - 24

Leaf spring type

Unit	N-m	kg-m	ft-lb
Shock absorber upper end nut	30 - 40	3.1 - 4.1	22 - 30
Shock absorber lower end nut	30 - 40	3.1 - 4.1	22 - 30
Leaf spring U-bolt nut	88 - 98	9.0 - 10.0	65 - 72
Spring front pin nut	78 - 98	8.0 - 10.0	58 - 72
Spring front pin bolt to frame			
(2WD)	16 - 21	1.6 - 2.1	12 - 15
(4WD)	16 - 22	1.6 - 2.2	12 - 16
Spring shackle	78 - 98	8.0 - 10.0	58 - 72
Bumper rubber fixing bolt	16 - 22	1.6 - 2.2	12 - 16

BRAKE SYSTEM

SECTION **BR**

CONTENTS

PRECAUTIONS AND PREPARATION	BR- 2
CHECK AND ADJUSTMENT	BR- 3
BRAKE HYDRAULIC LINE	BR- 4
BRAKE PEDAL AND BRACKET	BR- 7
BRAKE BOOSTER	BR- 9
VACUUM PIPING	BR-10
MASTER CYLINDER	BR-12
LOAD SENSING VALVE	BR-13
FRONT DISC BRAKE (CL28VA and CL28VD) – Caliper	BR-16
FRONT DISC BRAKE (CL28VA and CL28VD) – Rotor	BR-20
REAR DRUM BRAKE (DS22, DS25B, DS25C and LT26B)	BR-21
REAR DISC BRAKE (AD14VB) – Caliper	BR-26
REAR DISC BRAKE (AD14VB) – Rotor	BR-30
PARKING BRAKE CONTROL	BR-31
PARKING DRUM BRAKE (DS19HB) – Rear Disc Brake (AD14VB) Model	BR-34
SERVICE DATA AND SPECIFICATIONS (S.D.S.)	BR-36

PRECAUTIONS AND PREPARATION

Precautions

- Recommended fluid is brake fluid "DOT 3".
- Never reuse drained brake fluid.
- Be careful not to splash brake fluid on painted areas.
- To clean or wash all parts of master cylinder, disc brake caliper and wheel cylinder, use clean brake fluid.
- Never use mineral oils such as gasoline or kerosene. They will ruin the rubber parts of the hydraulic system.

WARNING:

- Clean pad and shoe dust using a dust collector after cleaning with waste cloth.

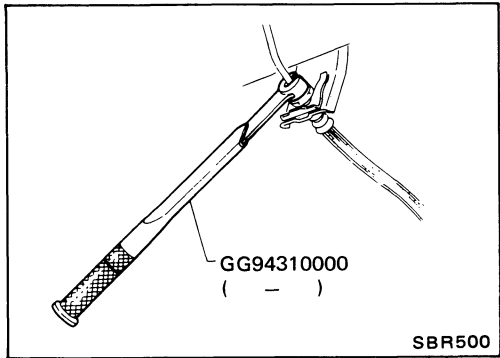

- Use Tool when removing and installing brake tube.

Preparation SPECIAL SERVICE TOOL

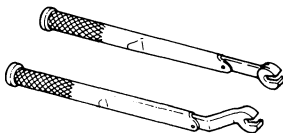
Tool number (Kent-Moore No.) Tool name	Description
GG94310000 (-) Flare nut torque wrench	 <p>Removing and installing each brake piping</p>

CHECK AND ADJUSTMENT

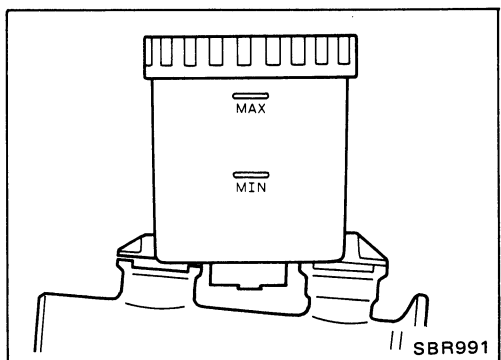

Checking Brake Fluid Level

- Check fluid level in reservoir tank. It should be between Max. and Min. lines on reservoir tank.
- If fluid level is extremely low, check brake system for leaks.

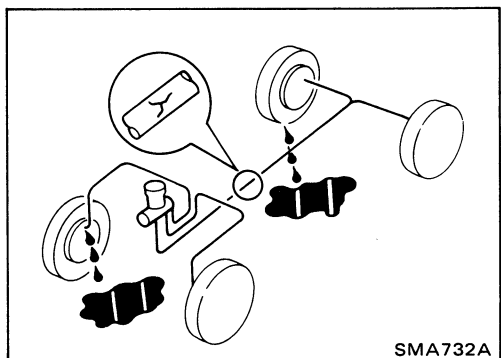

Checking Brake System

- Check brake lines (tubes and hoses) for evidence of cracks, deterioration or other damage. Replace any damaged parts. If leakage occurs around joints, retighten or, if necessary, replace damaged parts.
- Be sure to check for oil leakage by fully depressing brake pedal.

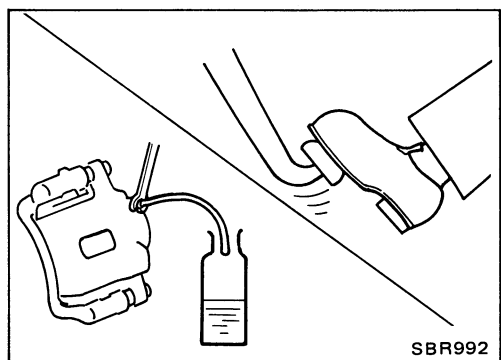

Changing Brake Fluid

1. Drain brake fluid in each air bleeder valve.
 2. Refill until new brake fluid comes out of each air bleeder valve.
- Use same procedure as in bleeding hydraulic system to refill brake fluid.
Refer to Bleeding Procedure of BRAKE HYDRAULIC LINE.
- Refill with recommended brake fluid "DOT 3".
 - Never reuse drained brake fluid.
 - Be careful not to splash brake fluid on painted areas.

BRAKE HYDRAULIC LINE

Model equipped with proportioning valve

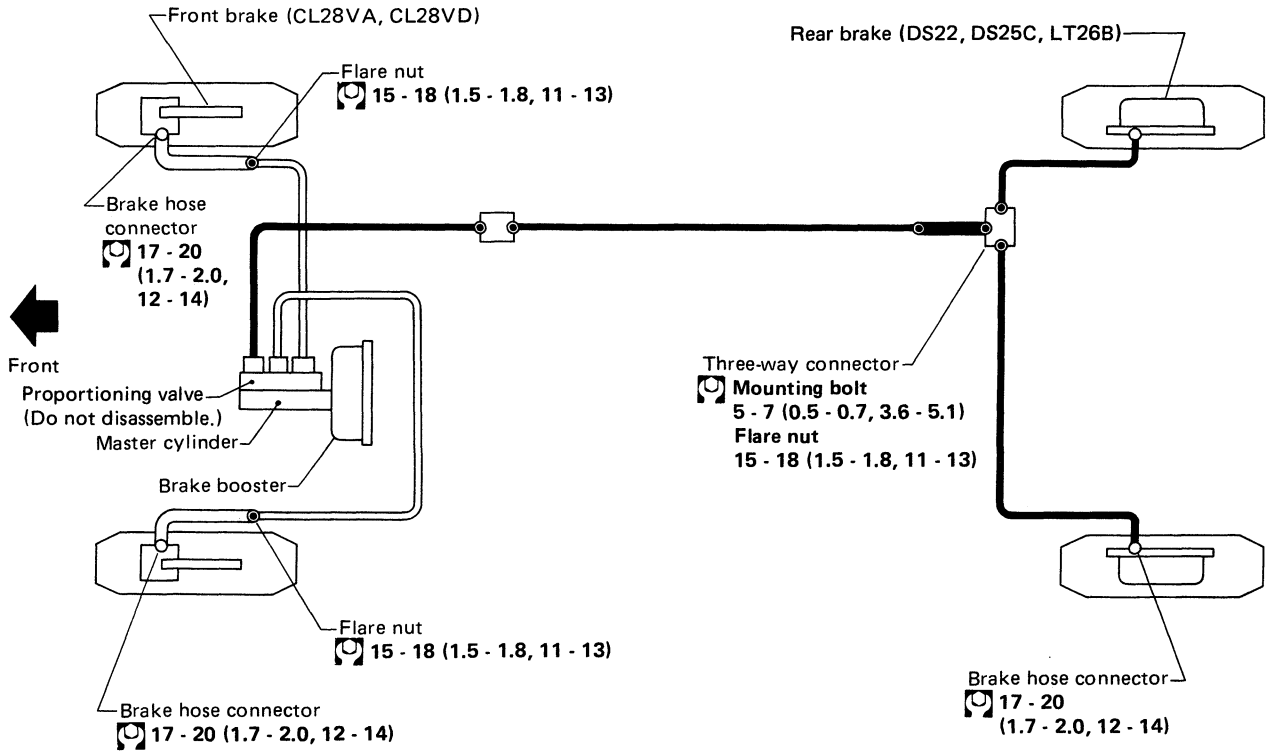

Model equipped with L.S.V. (A-type)

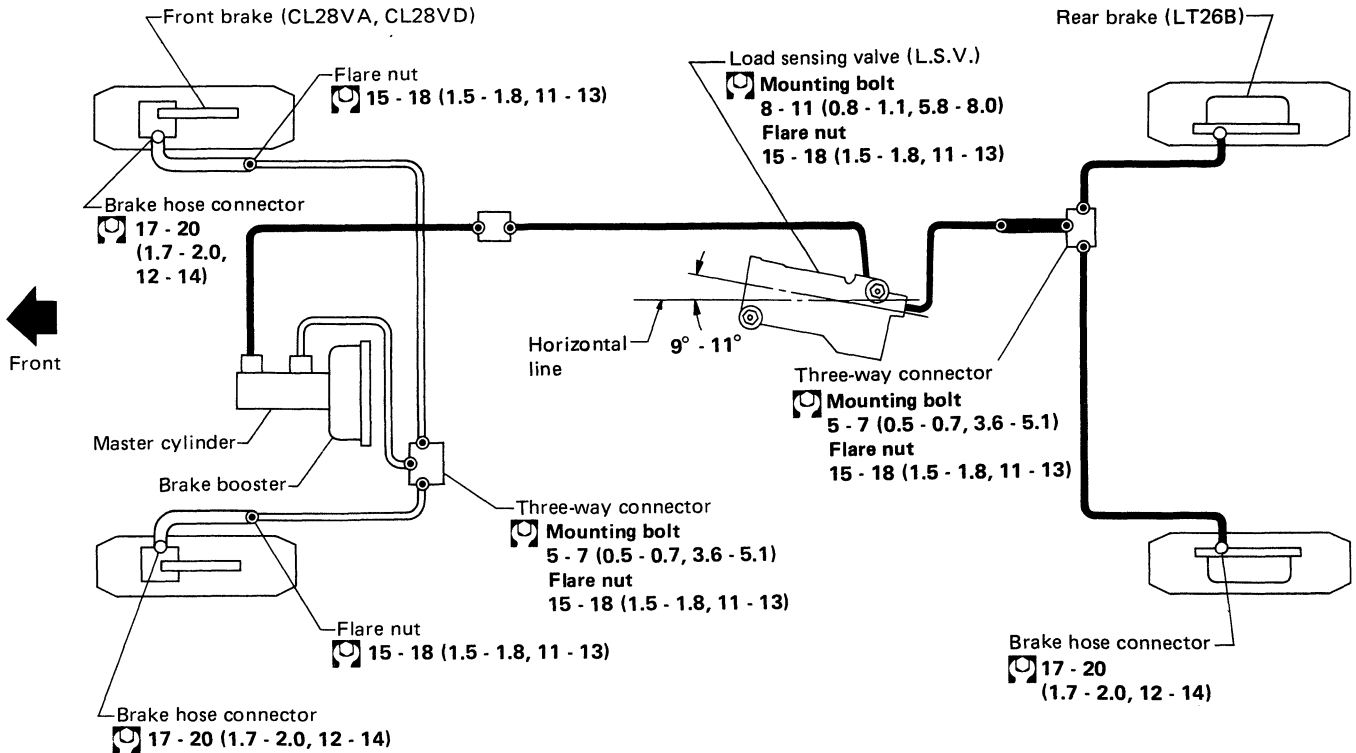

- ==== Primary line
- Secondary line
- ⊗ : N·m (kg·m, ft·lb)

BRAKE HYDRAULIC LINE

Model equipped with L.S.V. (B-type)

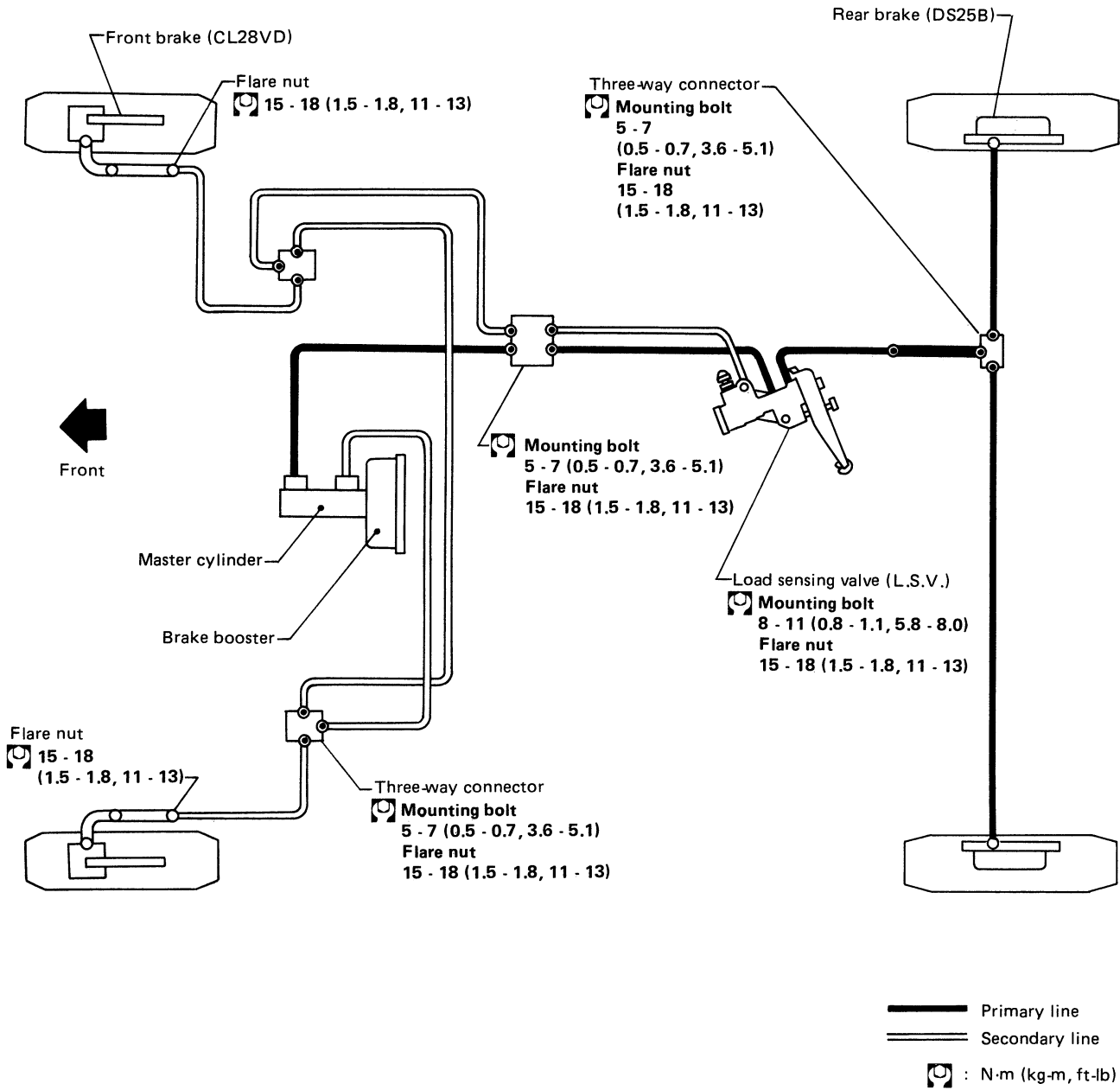

SBR169A

BRAKE HYDRAULIC LINE

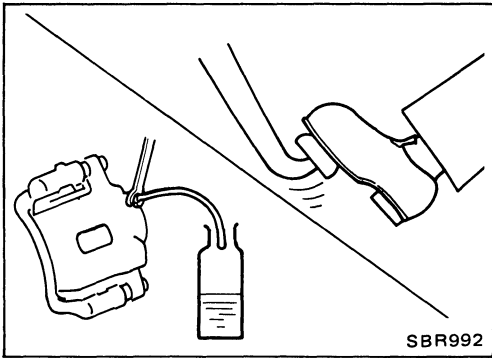

Bleeding Procedure

Model not equipped with L.S.V.

- Bleed air according to the following procedure:
Left rear wheel cylinder → Right rear wheel cylinder → Left front caliper → Right front caliper

Model equipped with L.S.V.

- Bleed air according to the following procedure:
L.S.V. air bleeder → Left rear wheel cylinder → Right rear wheel cylinder → Left front caliper → Right front caliper

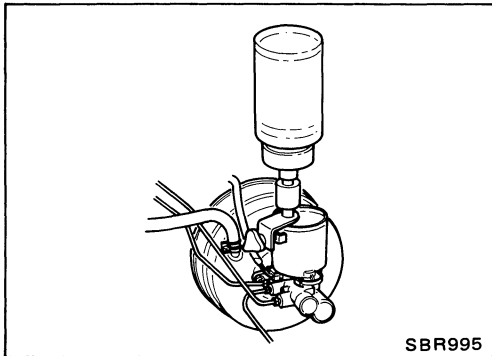

- Connect a transparent vinyl tube to air bleeder valve of L.S.V., caliper or wheel cylinder.
- Carefully monitor brake fluid level at master cylinder during bleeding operation.
- Tighten air bleeder to the specified torque.

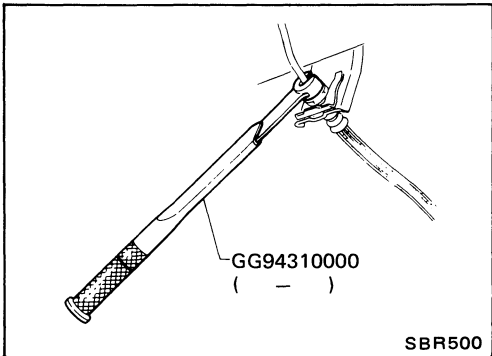

Removal and Installation

CAUTION:

- a. Use Tool when removing and installing brake tube.

- b. **Cover openings to prevent entrance of dirt whenever disconnecting hydraulic line.**

- To remove brake hose, first remove flare nut securing brake tube to hose, then withdraw lock spring. Next disconnect the other side.
- All hoses must be free from excessive bending, twisting and pulling.
- After installing brake lines, be sure to check for oil leakage by fully depressing brake pedal.

Inspection

Check brake lines (tubes and hoses) for evidence of cracks, deterioration or other damage. Replace any damaged parts.

If leakage occurs around joints, retighten or, if necessary, replace damaged parts.

BRAKE PEDAL AND BRACKET

Removal and Installation

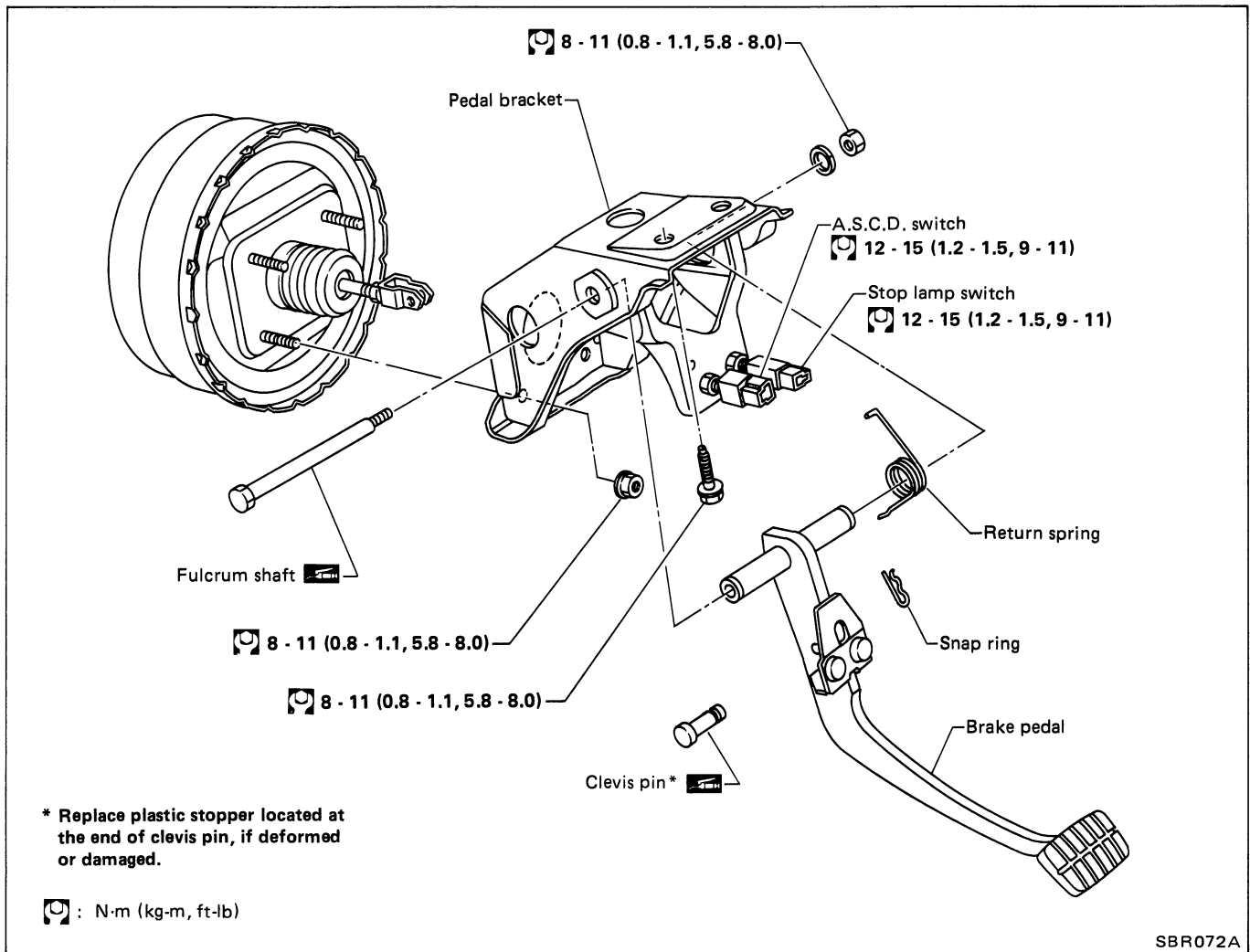

Inspection

Check brake pedal for the following items.

- Brake pedal bend
- Clevis pin deformation
- Crack of any welded portion

BRAKE PEDAL AND BRACKET

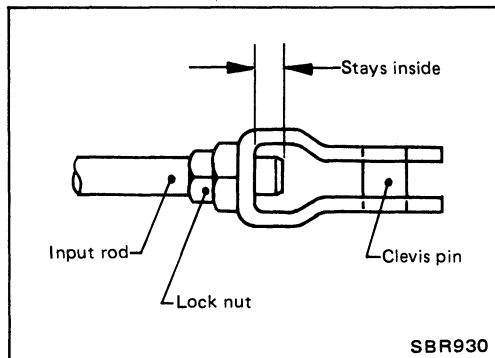
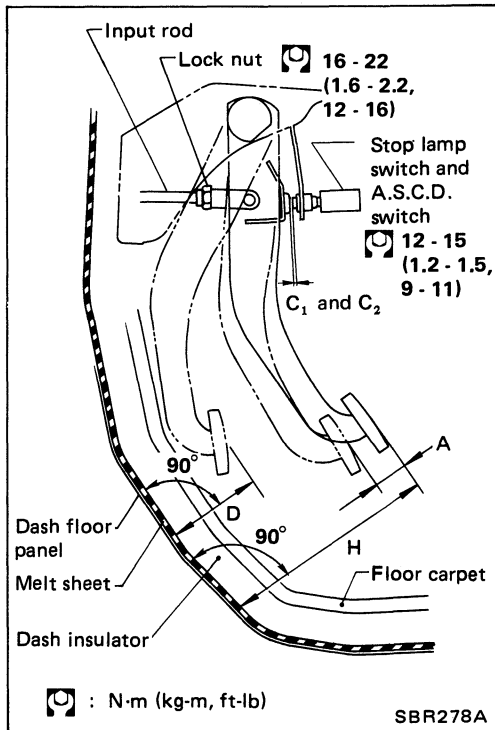

Adjustment

Check brake pedal free height from melt sheet. Adjust if necessary.

H: Free height

Refer to S.D.S.

D: Depressed height

Refer to S.D.S.

Under force of 490 N (50 kg, 110 lb) with engine running

C₁: Clearance between pedal stopper and threaded end of stop lamp switch

0.3 - 1.0 mm (0.012 - 0.039 in)

C₂: Clearance between pedal stopper and threaded end of A.S.C.D. switch

0.3 - 1.0 mm (0.012 - 0.039 in)

A: Pedal free play

1 - 3 mm (0.04 - 0.12 in)

1. Adjust pedal free height with brake booster input rod. Then tighten lock nut.

Make sure that the tip of input rod stays inside.

2. Adjust clearance "C₁" and "C₂" with stop lamp switch and A.S.C.D. switch respectively. Then tighten lock nuts.

3. Check pedal free play.

Make sure that stop lamp is off when pedal is released.

4. Check brake pedal depressed height with engine running.

If depressed height is below the specified value, check brake system for leaks, accumulation of air or any damage components such as master cylinder, wheel cylinder, etc. Make the necessary repairs, if necessary.

BRAKE BOOSTER

Removal and Installation

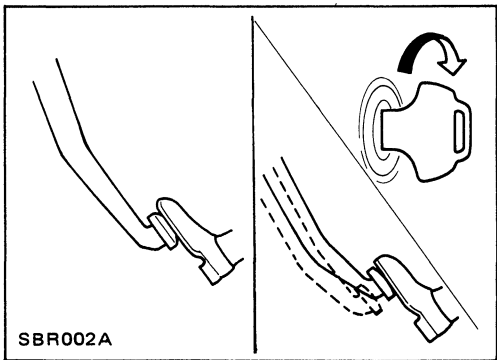
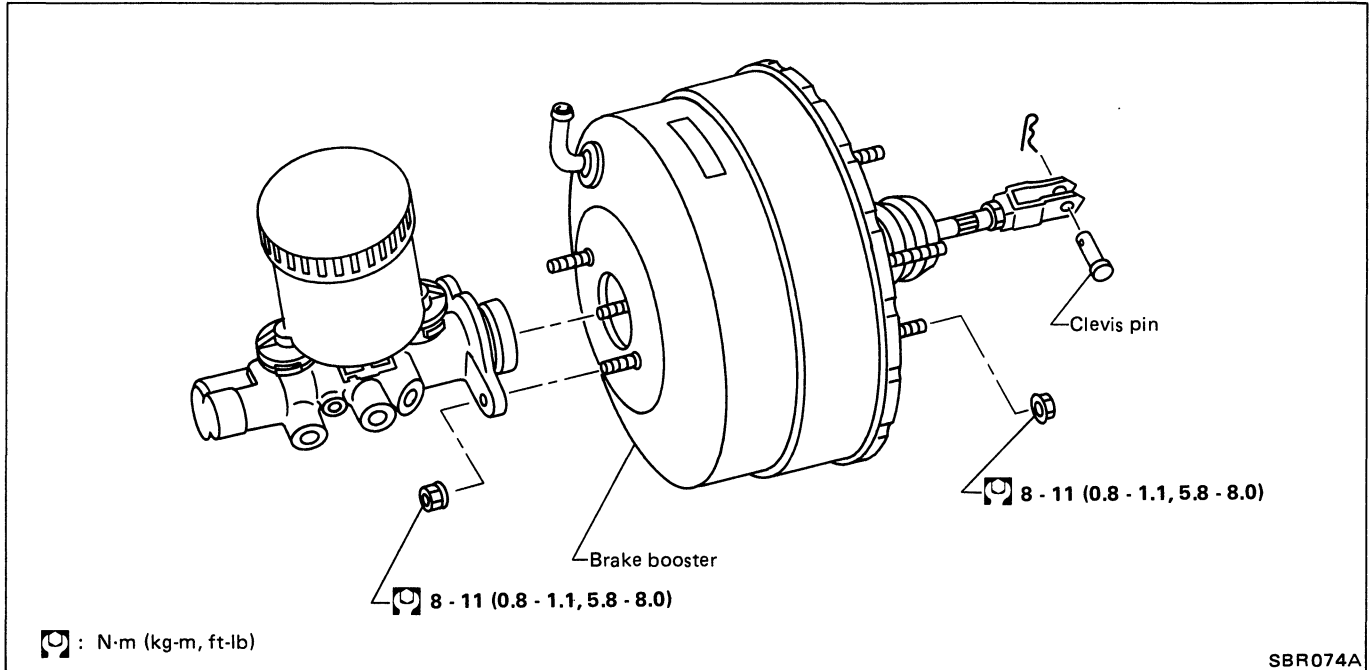

Inspection

OPERATING CHECK

- Depress brake pedal several times with engine off, then check that there is no change in pedal stroke.
- Depress brake pedal, then start engine. If pedal goes down slightly, operation is normal.

AIRTIGHT CHECK

- Start engine, then stop it in one or two minutes. Depress brake pedal several times slowly. If pedal goes further down the first time and gradually rises after second or third time, the booster is airtight.
- Depress brake pedal while engine is running, then stop engine with pedal depressed. If there is no change in pedal stroke for thirty seconds, brake booster is airtight.

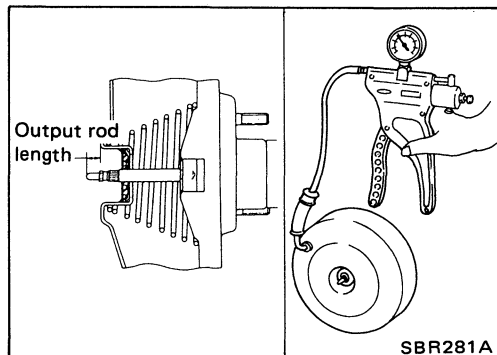

OUTPUT ROD LENGTH CHECK

1. Supply brake booster with vacuum of -66.7 kPa (-500 mmHg, -19.69 inHg) using a handy vacuum pump.
2. Check output rod length.

Specified length:

10.275 - 10.525 mm (0.4045 - 0.4144 in)

VACUUM PIPING

Removal and Installation

Gasoline engine models

(4 way type)

Check valve

Vacuum hose

(2 way type)

Check valve

Vacuum hose

CAUTION:
Do not apply any oil or lubricants to vacuum hose and check valve.

SBR496A

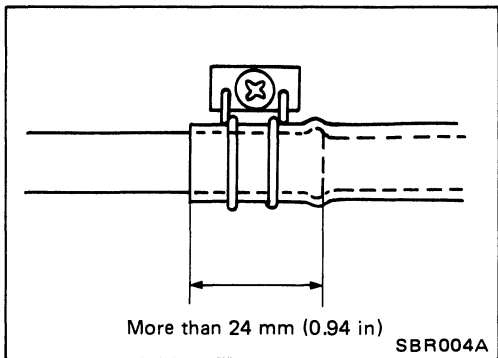

- Insert vacuum tube into vacuum hose more than 24 mm (0.94 in).

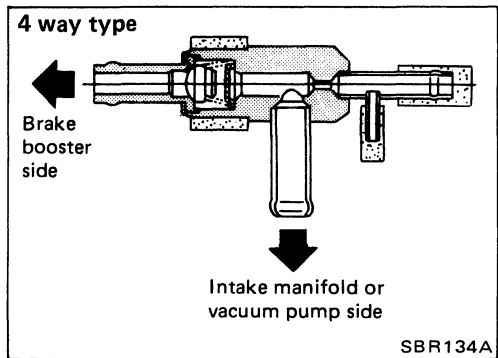

- Install check valve properly paying attention to its direction.

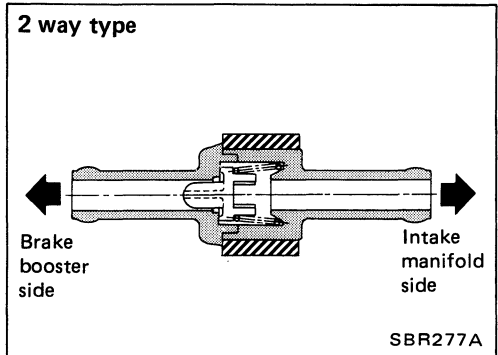

VACUUM PIPING

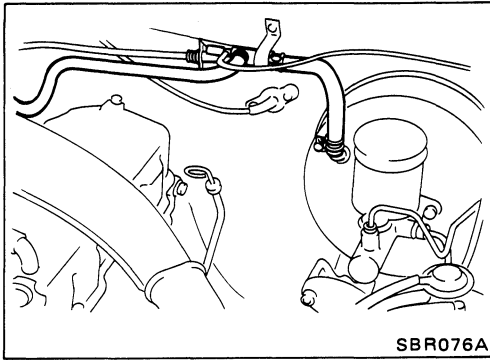

Inspection

HOSES AND CONNECTORS

- Check condition of vacuum hoses and connectors.
- Check vacuum hoses for air tightness.

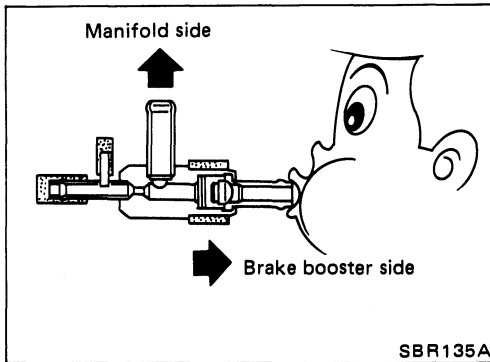

CHECK VALVE

- If valve does not open, replace check valve with a new one when pressure is applied to the brake booster side of check valve.

MASTER CYLINDER

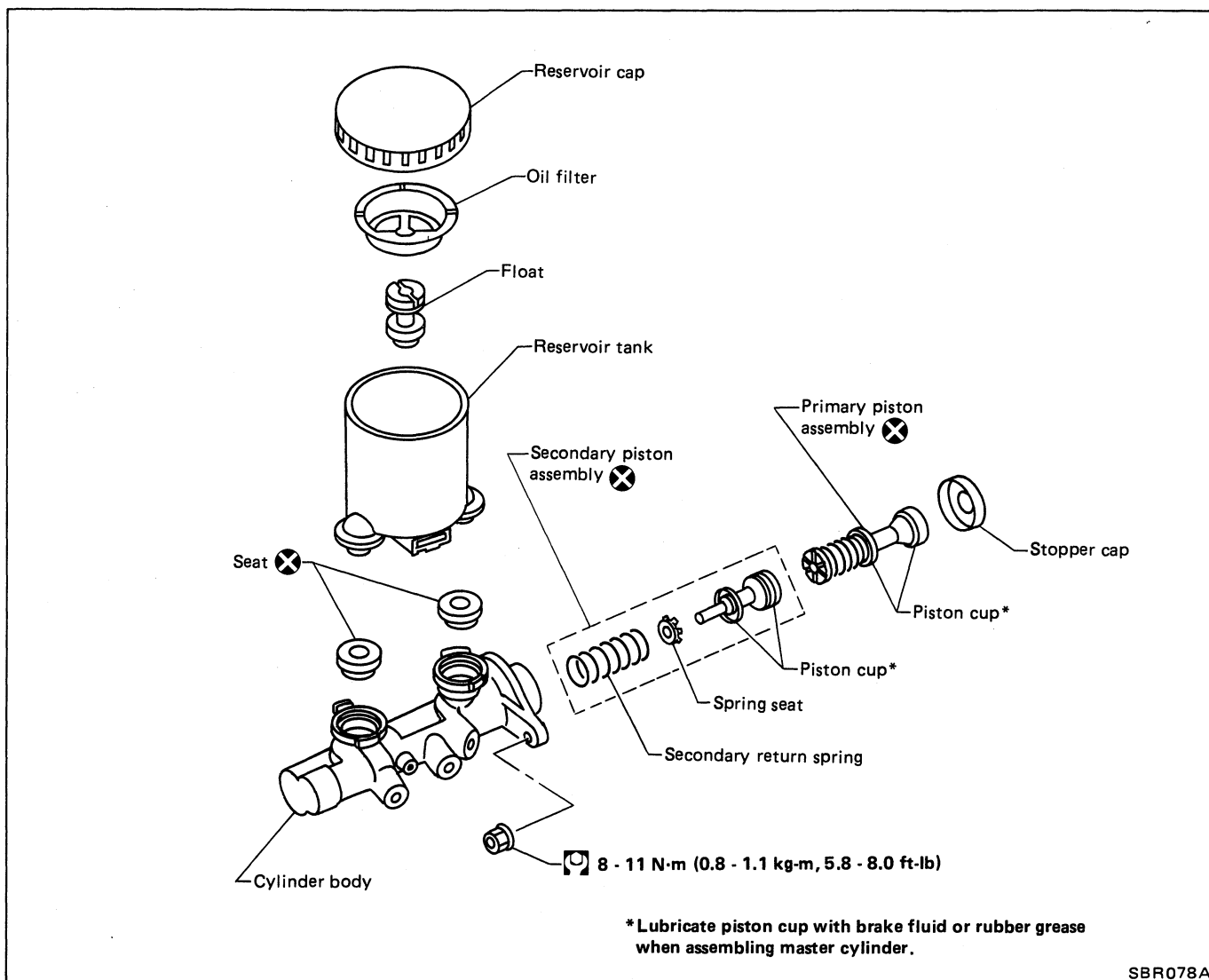

SBR078A

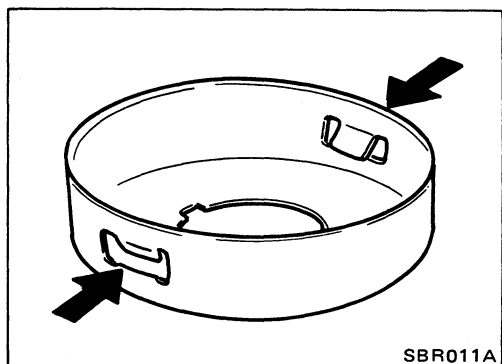

- Replace stopper if the claw is damaged or deformed.
- Bend claws inside when installing stopper.

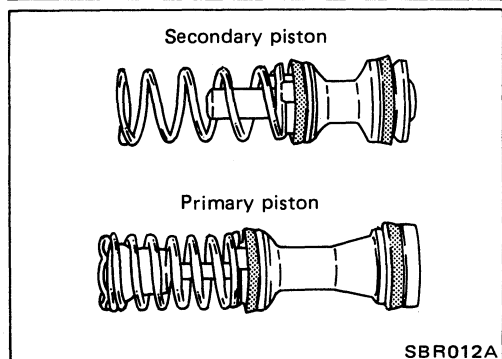

- Replace piston assembly when disassembled.
- Pay attention to the direction of piston cups.
- Check parts for wear or damage. Replace if any of the above conditions are observed.

LOAD SENSING VALVE

Load Sensing Valve (A-type)

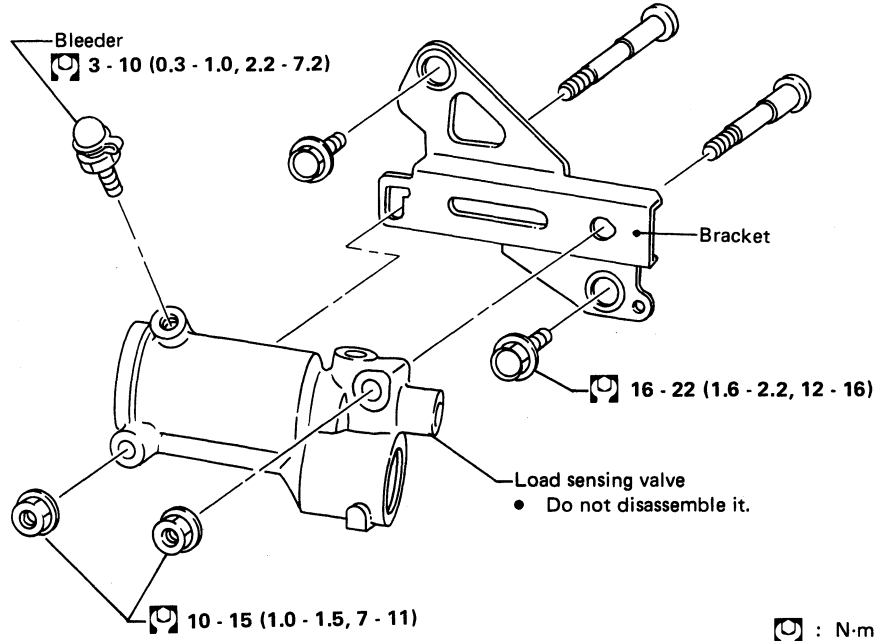

SBR122A

- Do not reuse Load Sensing Valve once it is disassembled.
- Replace damaged Load Sensing Valve as an assembly.

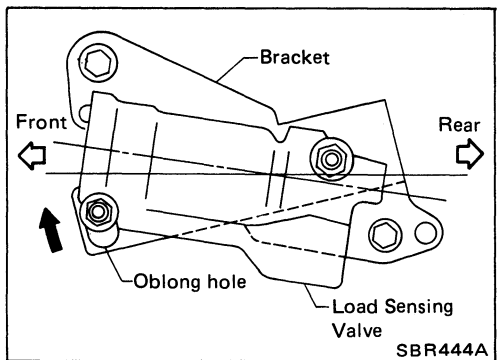

- When installing Load Sensing Valve to bracket, secure it to area above oblong hole.

LOAD SENSING VALVE

Load Sensing Valve (B-type)

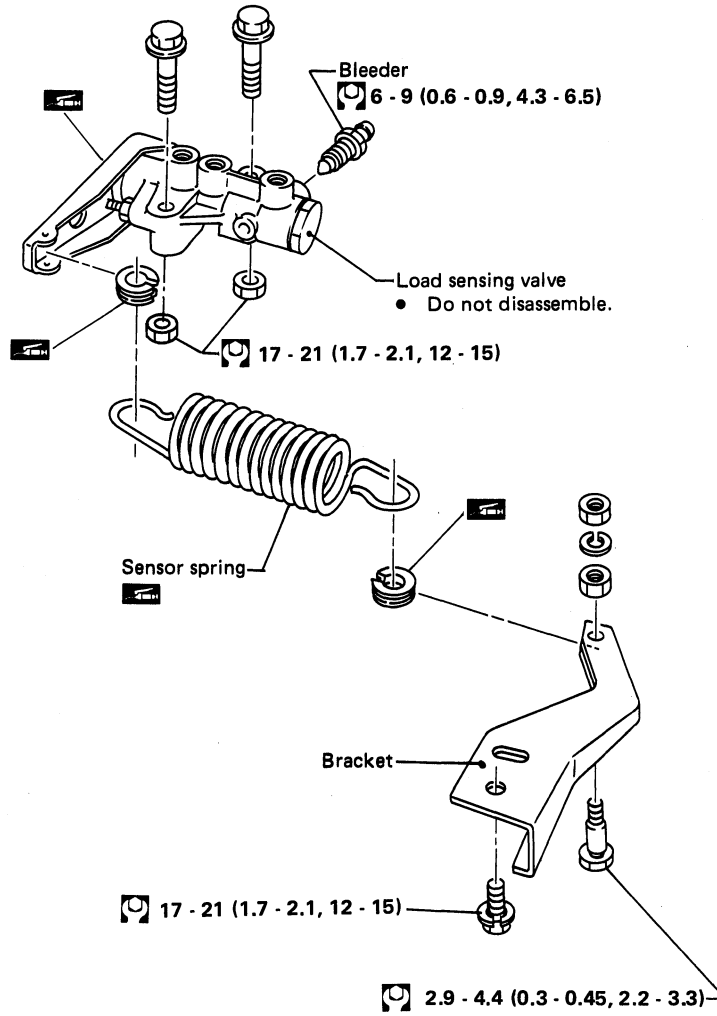

SBR123A

- Do not reuse Load Sensing Valve once it is disassembled.
- Replace damaged Load Sensing Valve as an assembly.
- When disassembling, apply multi-purpose grease to all rubbing areas.

LOAD SENSING VALVE

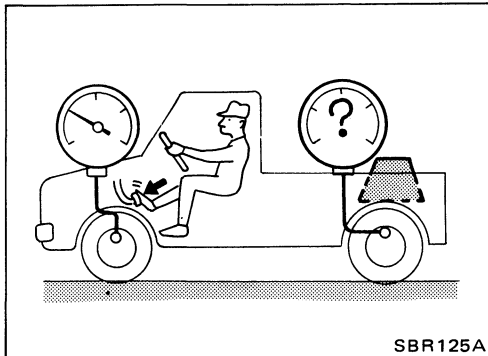
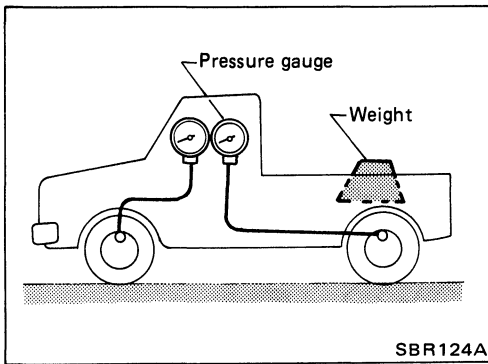

Inspection (L. S. V. B-type)

1. Set weight slowly on axle center.

Weight: 100 kg (221 lb)

2. Install pressure gauge to front and rear brake.

3. Raise front brake pressure to 4,904 kPa (50 kg/cm², 711 psi) and check rear brake pressure.

Rear brake pressure:

2,256 - 3,236 kPa

(23 - 33 kg/cm², 327 - 469 psi)

4. Raise front brake pressure to 9,807 kPa (100 kg/cm², 1,422 psi) and check rear brake pressure.

Rear brake pressure:

3,138 - 4,511 kPa

(32 - 46 kg/cm², 455 - 654 psi)

If rear brake pressure is not within specification, adjust bracket as follows:

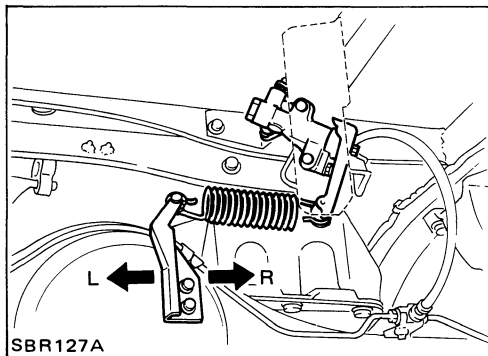

5. Adjust bracket to direction of L when rear brake pressure is above specification.

6. Adjust bracket to direction of R when rear brake pressure is below specification.

Repeat steps (3) and (4) until rear brake pressure is within specification.

FRONT DISC BRAKE (CL28VA and CL28VD) — Caliper

CL28VA

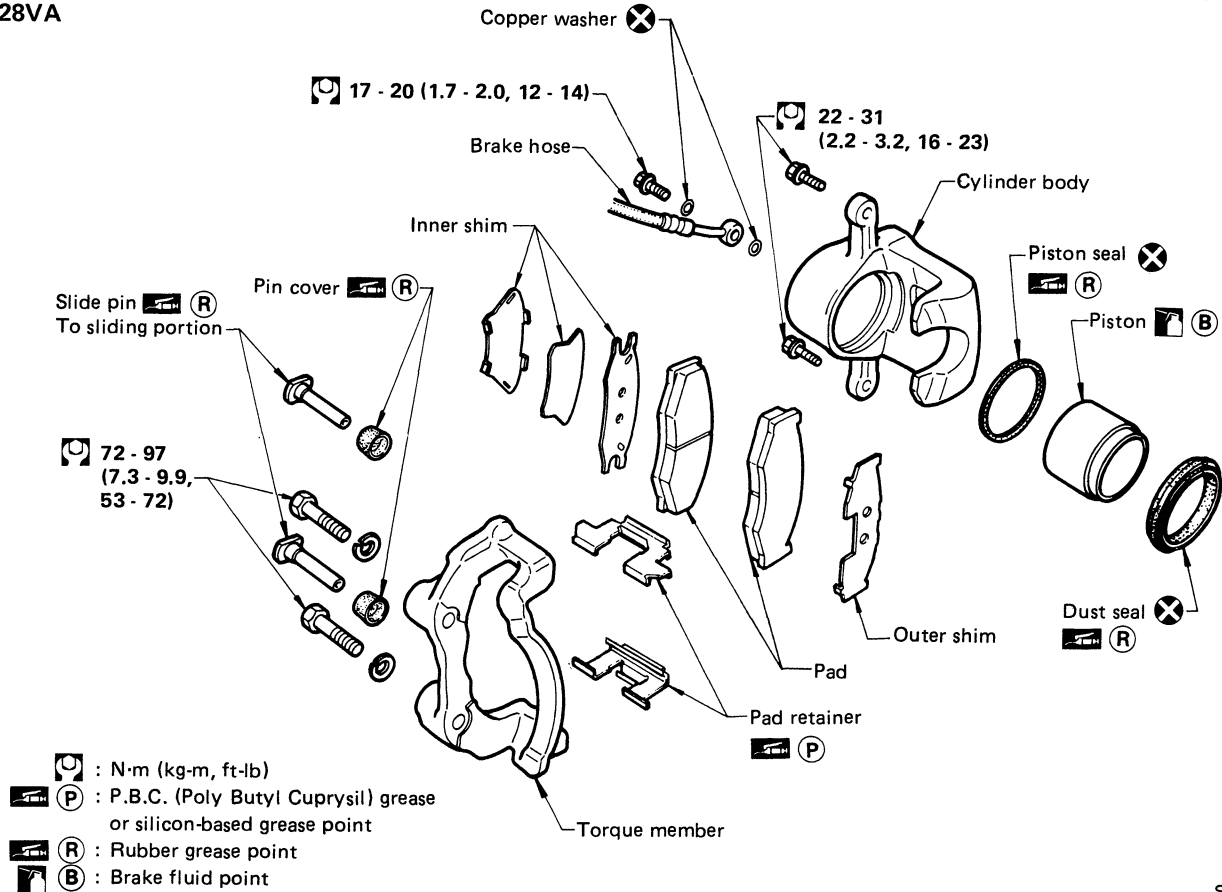

SBR272A

CL28VD

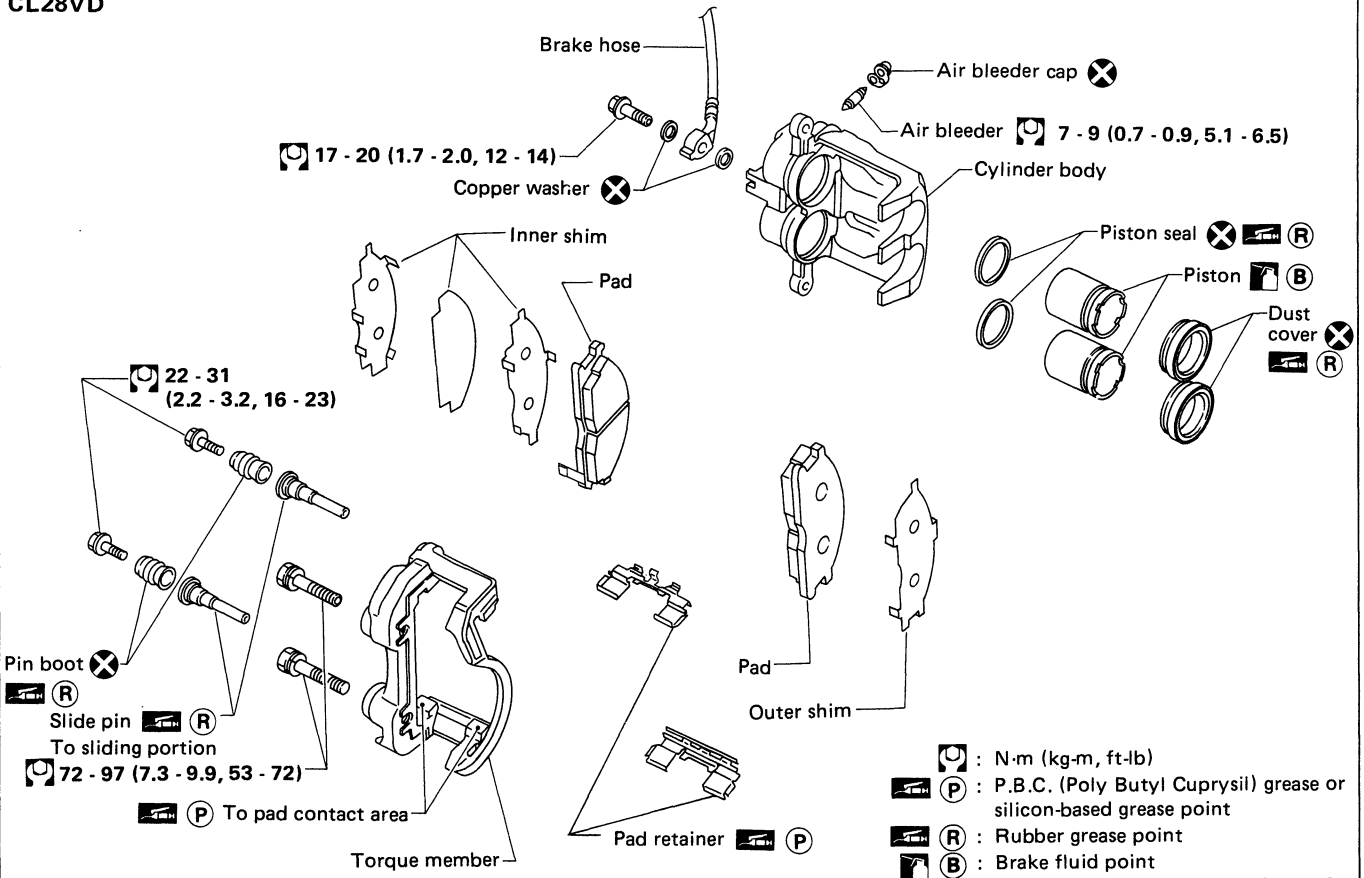

SBR273A

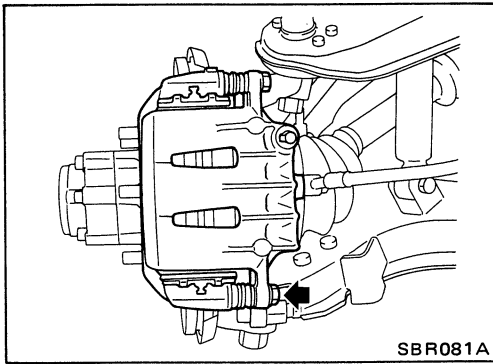

Pad Replacement

1. Remove pin bolt.

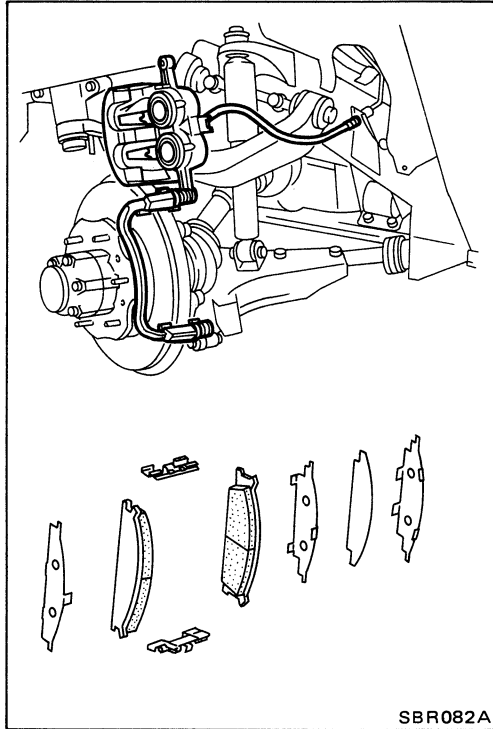

2. Swing cylinder body upward. Then remove pad retainers, and inner and outer shims.

CAUTION:

- When cylinder body is swung up, do not depress brake pedal because piston will pop out.
- Be careful not to damage dust cover or get oil on rotor. Always replace shims when replacing pads.

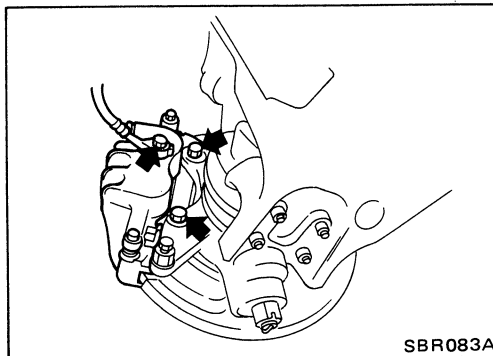

Removal and Installation

- Remove torque member fixing bolts and union bolt.

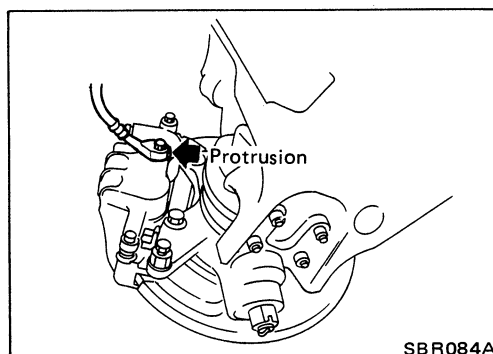

- Install brake hose to caliper securely.

FRONT DISC BRAKE (CL28VA and CL28VD) — Caliper

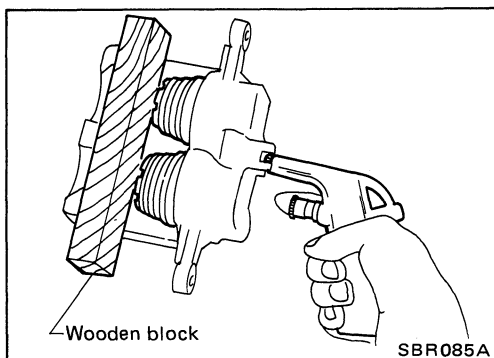

Disassembly

Push out piston with dust cover with compressed air.
For CL28VD (2-piston type), use a wooden block so that the 2 pistons come out evenly.

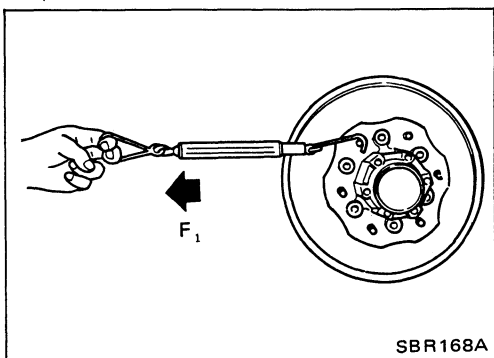

Inspection

INSPECTION OF BRAKE DRAG FORCE

- (1) Swing cylinder body upward.
- (2) Make sure that wheel bearing is adjusted properly. Refer to section FA.
- (3) Measure rotating force (F_1).

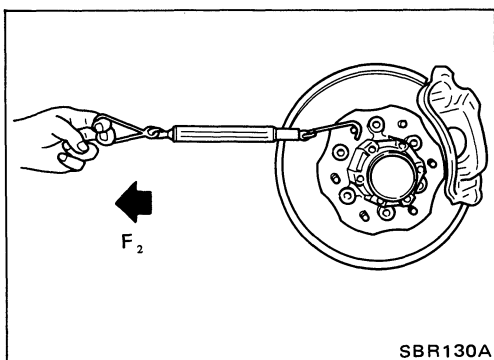

- (4) Install caliper with pads to the original position.
- (5) Depress brake pedal for 5 seconds.
- (6) Release brake pedal, rotate disc rotor 10 revolutions.
- (7) Measure rotating force (F_2).
- (8) Calculate brake drag force by subtracting F_1 from F_2 .

Maximum brake drag force ($F_2 - F_1$):

103.0 N (10.5 kg, 23.2 lb)

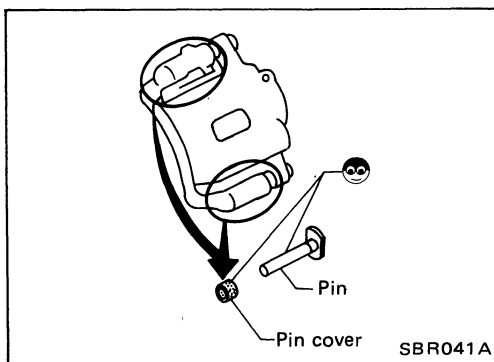

If it is not within specification, check pins and pin boots in caliper.

- Make sure that wheel bearing is adjusted properly.
- Disc pads and disc rotor must be dried.

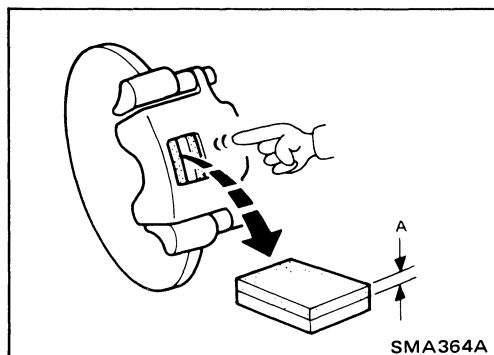

DISC PAD

Check disc pad for wear or damage.

Pad wear limit (A):

2.0 mm (0.079 in)

Inspection (Cont'd)

CYLINDER BODY

- Check inside surface of cylinder for score, rust, wear, damage or presence of foreign materials. If any of the above conditions are observed, replace cylinder body.
- Minor damage from rust or foreign materials may be eliminated by polishing the surface with a fine emery paper. Replace cylinder body if necessary.

CAUTION:

Use brake fluid to clean. Never use mineral oil.

PISTON

Check piston for score, rust, wear, damage or presence of foreign materials. Replace if any of the above conditions are observed.

CAUTION:

Piston sliding surface is plated. Do not polish with emery paper even if rust or foreign materials are stuck to sliding surface.

PIN, PIN BOLT AND PIN BOOT

Check for wear, cracks or other damage. Replace if any of the above conditions are observed.

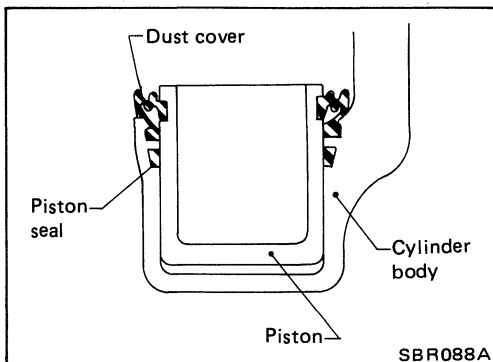
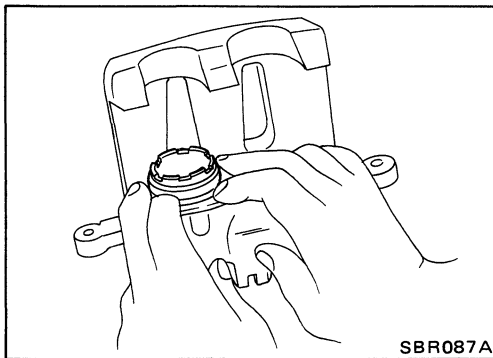

Assembly

- Insert piston seal into groove on cylinder body.
- With dust seal fitted to piston, install piston into cylinder body.

CAUTION:

- Secure dust seal properly.

FRONT DISC BRAKE (CL28VA and CL28VD) — Rotor

Inspection

RUBBING SURFACE

Check rotor for roughness, cracks or chips.

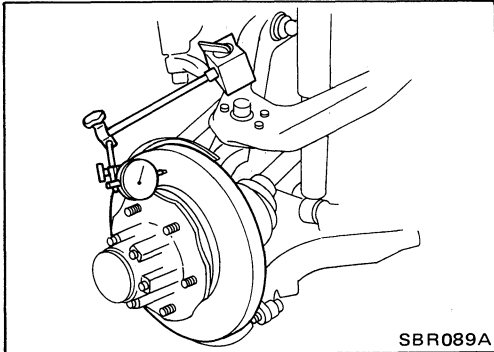

RUNOUT

Make sure that axial end play is within the specifications before measuring. Refer to section FA.

Rotor repair limit:

Maximum runout

(Total indicator reading at center of rotor pad contact surface)

0.07 mm (0.0028 in)

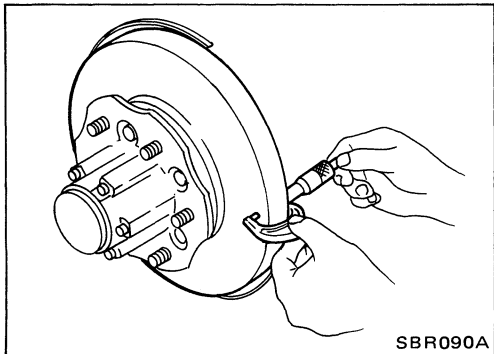

THICKNESS

Rotor repair limit:

Minimum thickness

CL28VA 20.0 mm (0.787 in)

CL28VD 24.0 mm (0.945 in)

REAR DRUM BRAKE (DS22, DS25B, DS25C and LT26B)

DS22, DS25B

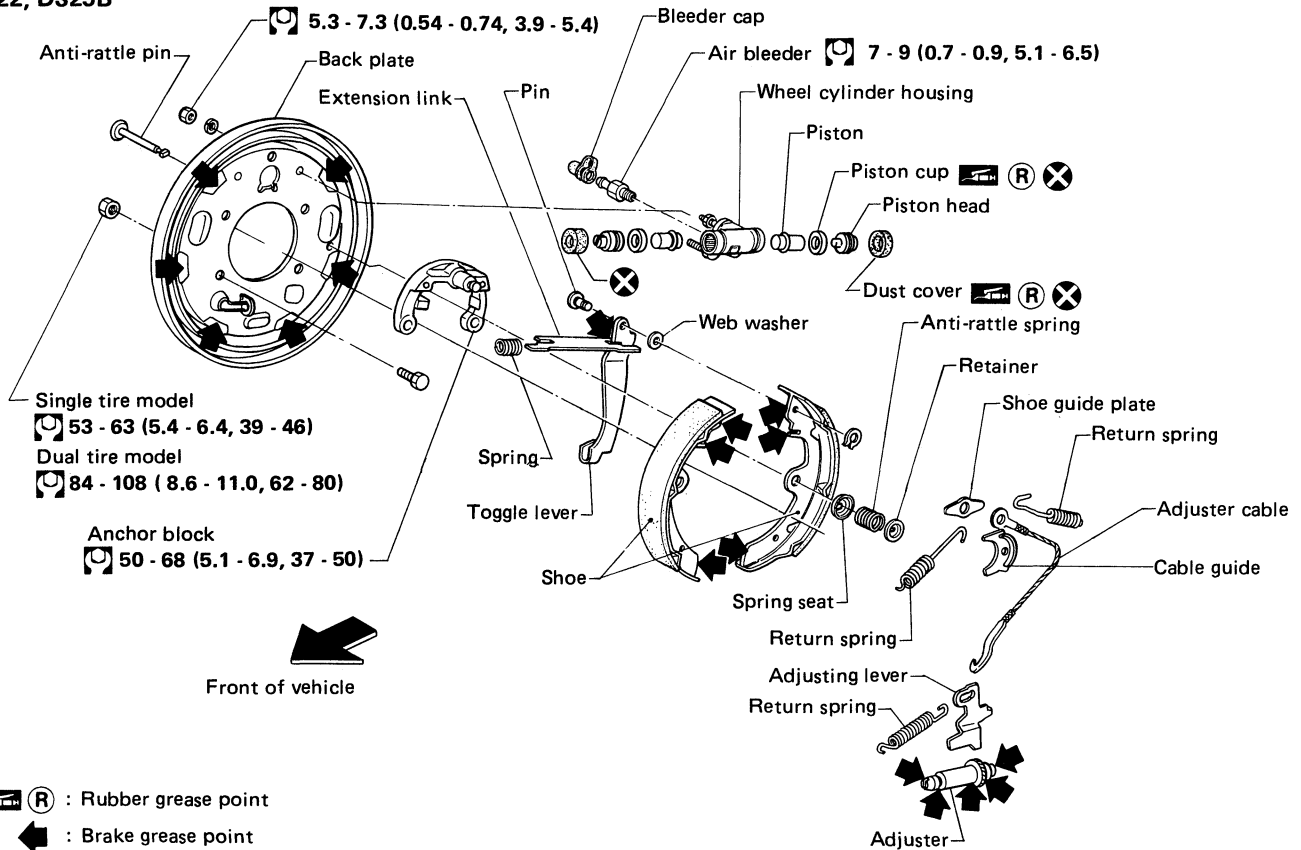

SBR091A

DS25C

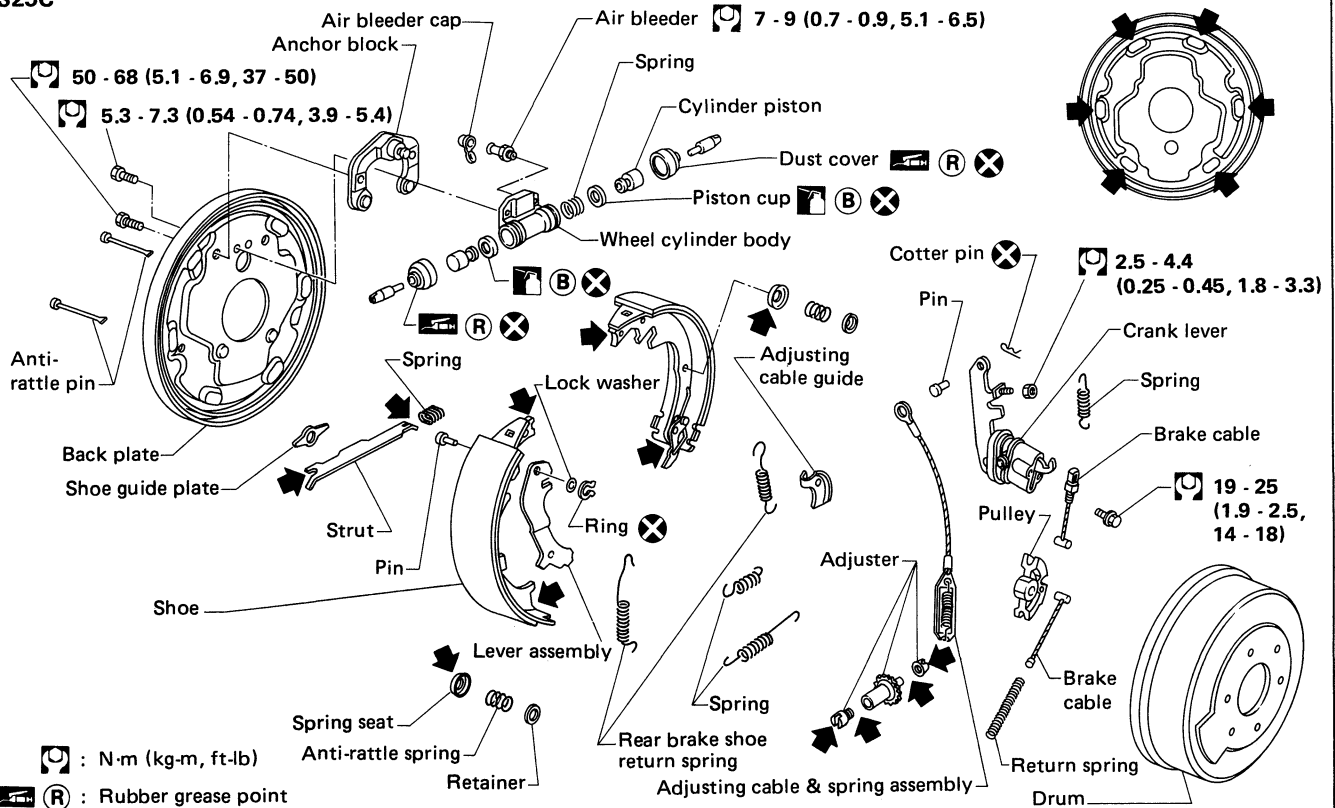

SBR092A

REAR DRUM BRAKE (DS22, DS25B, DS25C and LT26B)

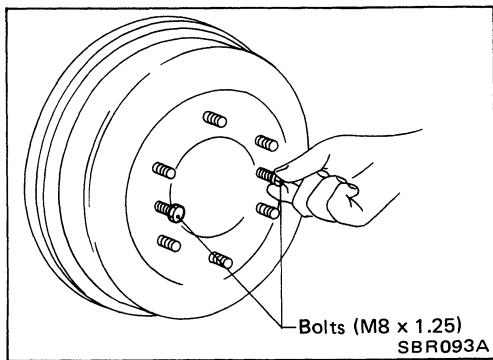
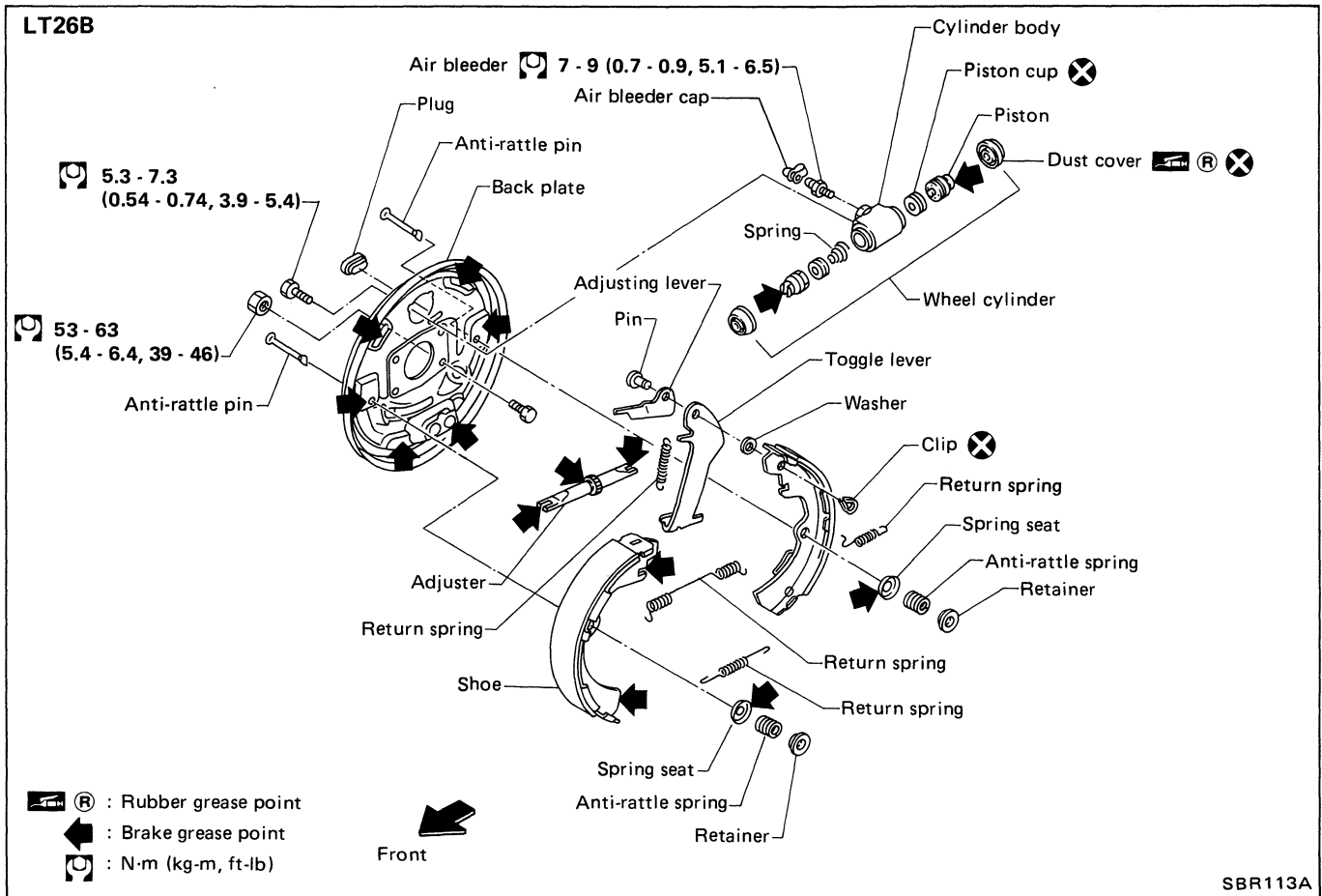

Brake Drum Removal

- Release parking brake control lever fully.
- Tighten two bolts gradually if brake drum is hard to remove.

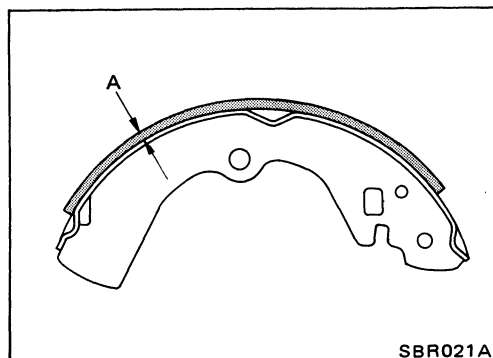

Shoe Replacement

- Measure lining thickness.

Lining wear limit (A):

1.5 mm (0.059 in)

Before installing new shoes, rotate nut until adjuster rod is at its shortest point.

After installation is completed, adjust shoe-to-drum clearance. Refer to Removal and Installation of Adjuster.

Wheel Cylinder Inspection

Check parts for score, wear or damage. Replace if any of the above conditions are observed.

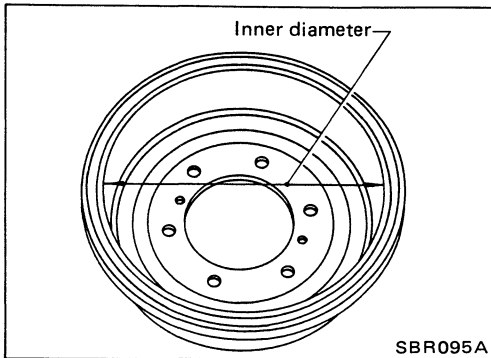
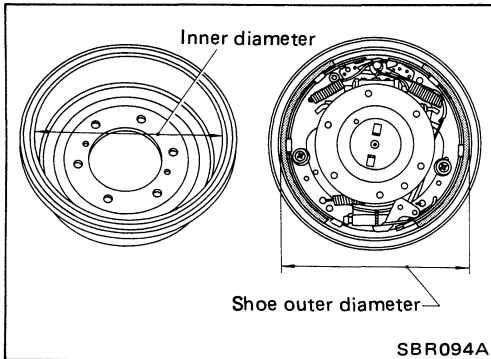

Removal and Installation of Adjuster

When installing, measure inner diameter of the drum and adjust so that shoe outer diameter at its center is smaller than drum inner diameter by 0.25 to 0.4 mm (0.0098 to 0.0157 in) by rotating the adjuster. Then operate parking brake lever to adjust shoe clearance.

Drum Inspection

Standard inner diameter:

DS22	220.0 mm (8.66 in)
DS25B, DS25C	254.0 mm (10.00 in)
LT26B	260.0 mm (10.24 in)

Maximum inner diameter:

DS22	221.5 mm (8.72 in)
DS25B, DS25C	255.5 mm (10.06 in)
LT26B	261.5 mm (10.30 in)

Out-of-roundness (ellipticity):

0.03 mm (0.0012 in) or less

Radial runout (Total indicator reading):

0.05 mm (0.0020 in) or less

- Contact surface should be finefinished with No. 120 to 150 emery paper.
- Using a drum racer, lathe brake drum if it shows score marks, partial wear or stepped wear.
- After brake drum has been completely reconditioned or replaced, check drum and shoes for proper contact pattern.

REAR DRUM BRAKE (DS22, DS25B, DS25C and LT26B)

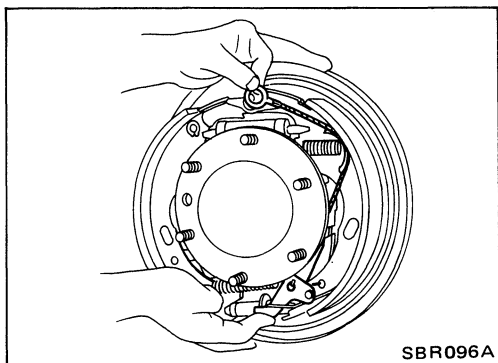

Shoe Installation

- Place adjuster cable by pulling adjusting lever upward.

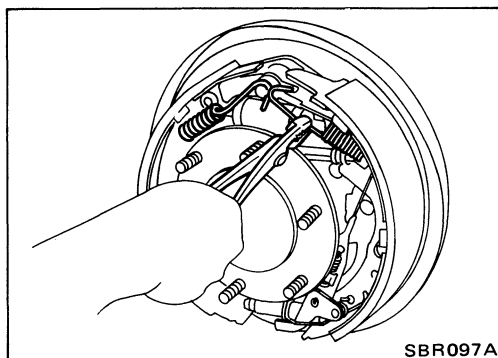

- Install return springs.

REAR DRUM BRAKE (DS22, DS25B, DS25C and LT26B)

Shoe Installation (Cont'd)

- Install all the parts by referring to the figure below.

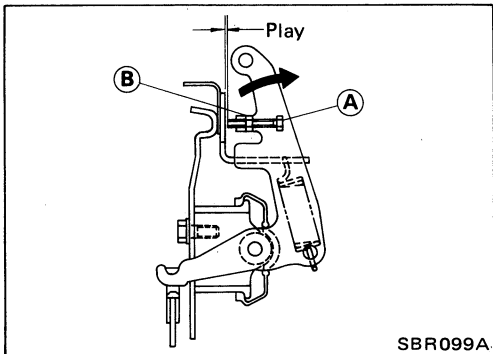
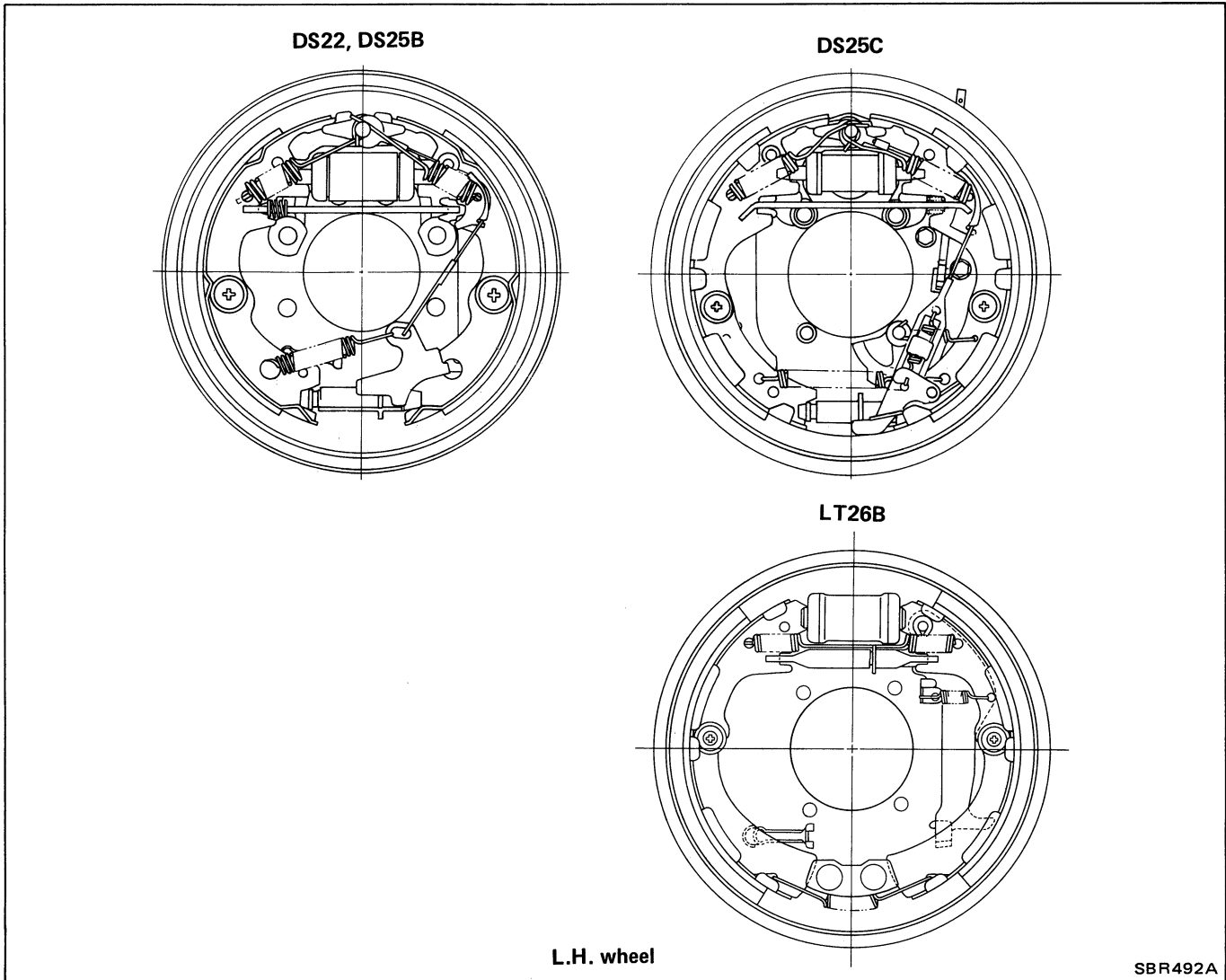

DS25C model

- After installing crank lever on back plate, make sure that there is no play between crank lever and back plate when pulling crank lever. If play exists, adjust bolt **A** and lock nut **B**.

REAR DISC BRAKE (AD14VB) — Caliper

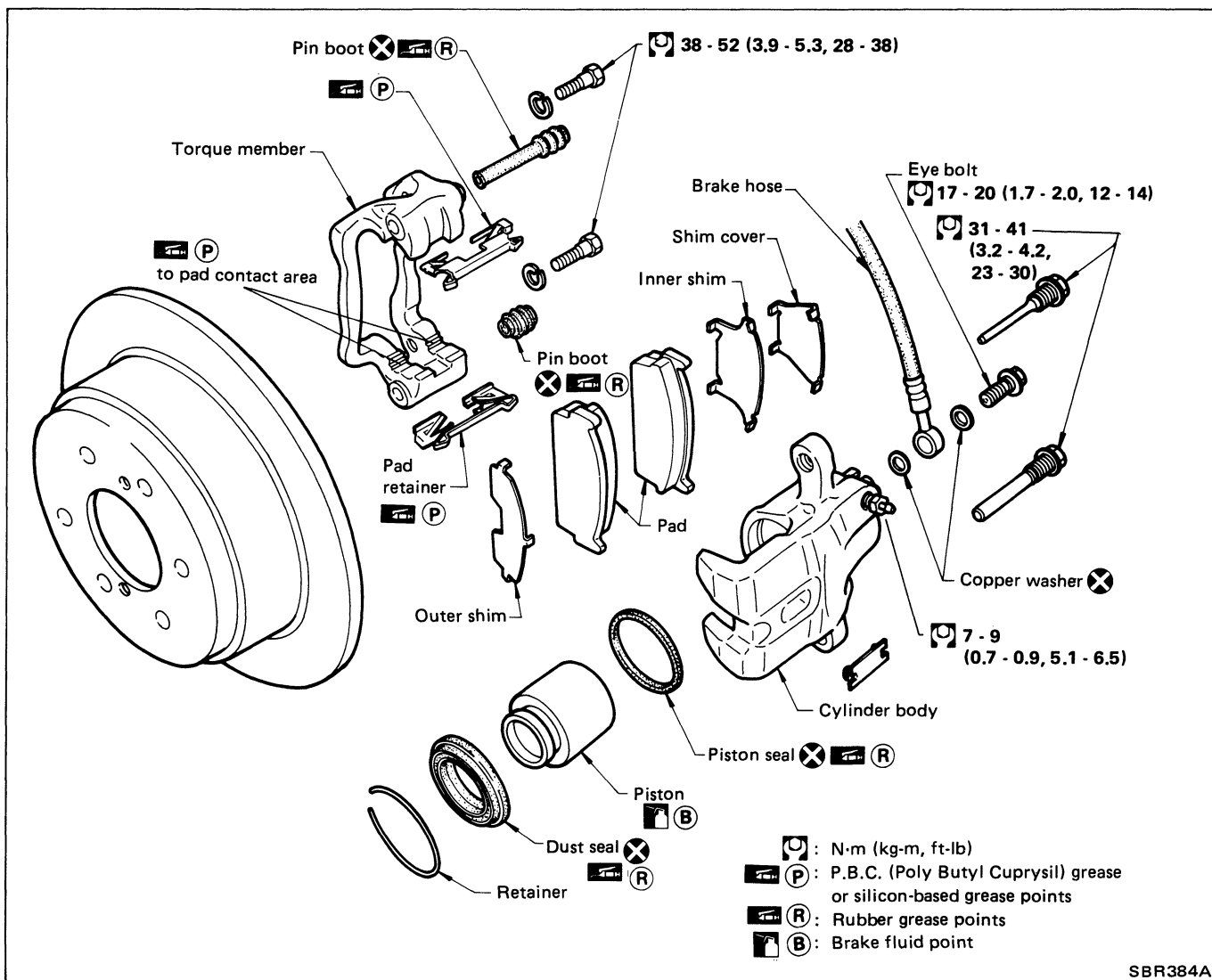

SBR384A

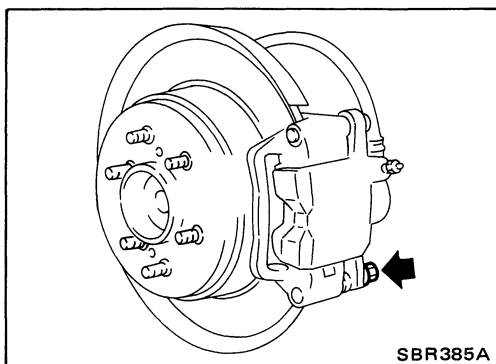

Pad Replacement

1. Remove guide pin.

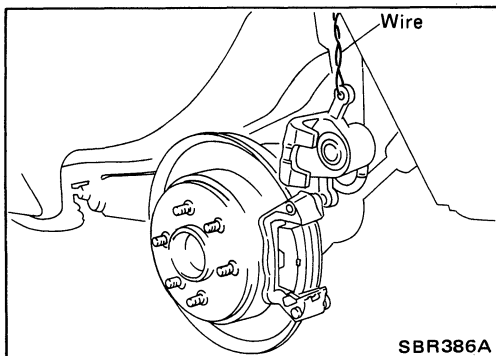

2. Swing cylinder body upward. Then remove pad retainer and inner and outer shims.

CAUTION:

- When cylinder body is swung up, do not depress brake pedal because piston will pop out.
- Be careful not to damage dust seal or get oil on rotor. Always replace shims when replacing pads.

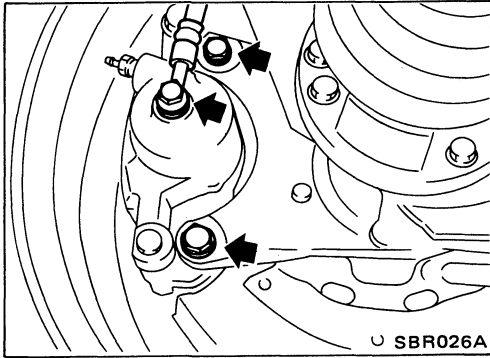

Removal and Installation

- Remove torque member fixing bolts and eye bolt.

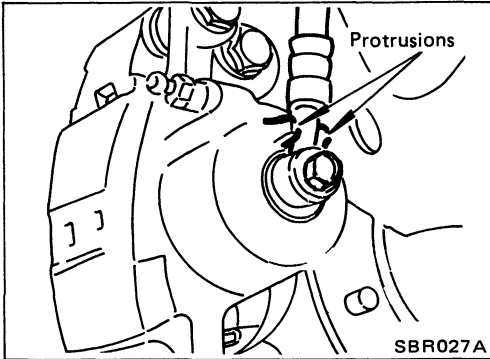

- Install brake hose to caliper securely.

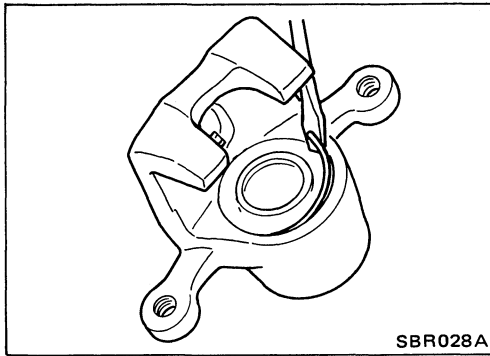

- Remove retainer with a screwdriver.

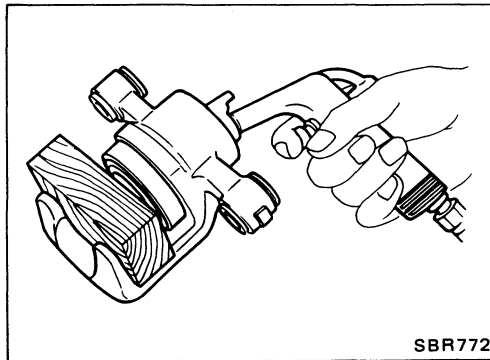

- Push out piston with dust seal with compressed air.

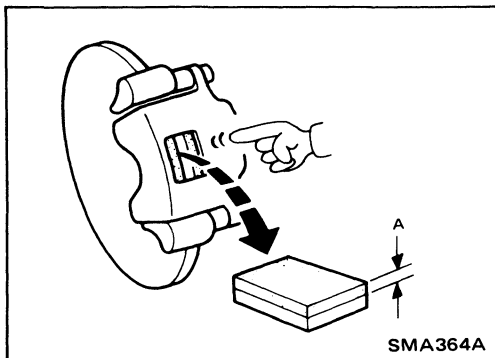
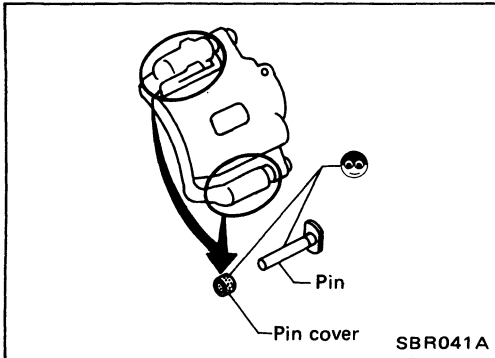
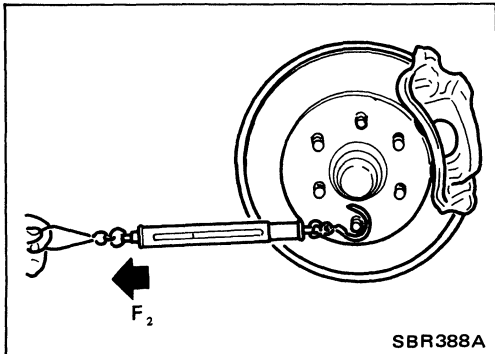
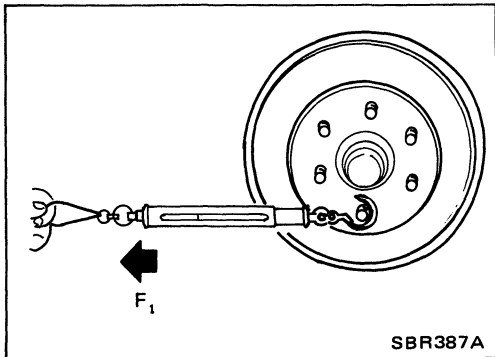

Inspection

INSPECTION OF BRAKE DRAG FORCE

- (1) Swing cylinder body upward.
- (2) Make sure that wheel bearing is adjusted properly. Refer to section RA.
- (3) Measure rotating force (F_1).

- (4) Install caliper with pads to the original position.
- (5) Depress brake pedal for 5 seconds.
- (6) Release brake pedal, rotate disc rotor 10 revolutions.
- (7) Measure rotating force (F_2).
- (8) Calculate brake drag force by subtracting F_1 from F_2 .

Maximum brake drag force ($F_2 - F_1$):

103.0 N (10.5 kg, 23.2 lb)

If it is not within specification, check pins and pin boots in caliper.

- Make sure that wheel bearing is adjusted properly.
- Disc pads and disc rotor must be dried.

DISC PAD

Check disc pad for wear or damage.

Pad wear limit (A):

2.0 mm (0.079 in)

CYLINDER BODY

- Check inside surface of cylinder body for score, rust, wear, damage or presence of foreign materials. If any of the above conditions are observed, replace cylinder body.
- Minor damage from rust or foreign materials may be eliminated by polishing surface with a fine emery paper. Replace cylinder body if necessary.

CAUTION:

Use brake fluid to clean. Never use mineral oil.

Inspection (Cont'd)

PISTON

Check piston for score, rust, wear, damage or presence of foreign materials. Replace if any of the above conditions are observed.

CAUTION:

Piston sliding surface is plated. Do not polish with emery paper even if rust or foreign materials are stuck to sliding surface.

PIN, PIN BOLT, RETAINER, PISTON SEAL,

DUST SEAL AND PIN BOOT

Check for wear, cracks or other damage. Replace if any of the above conditions are observed.

Assembly

- With dust seal fitted to piston, insert dust seal into groove on cylinder body and install piston.
- Properly secure dust seal.

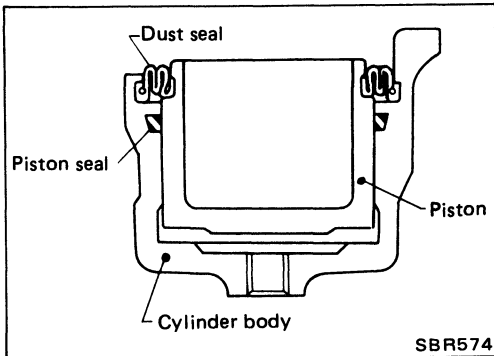

REAR DISC BRAKE (AD14VB) — Rotor

Inspection

RUBBING SURFACE

Check rotor for roughness, cracks or chips. Repair or replace if necessary.

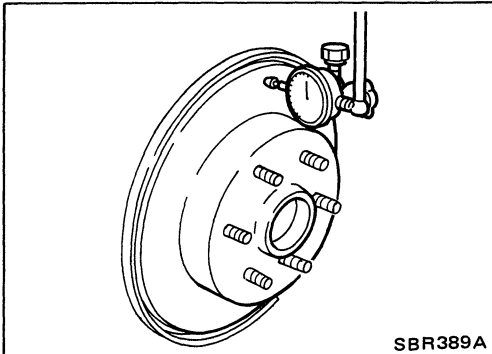

RUNOUT

Make sure that axial end play is within the specifications before measuring. Refer to section RA.

Then check runout with a dial gauge.

Rotor repair limit

Maximum runout

(Total indicator reading at center of rotor pad contact surface)

0.07 mm (0.0028 in)

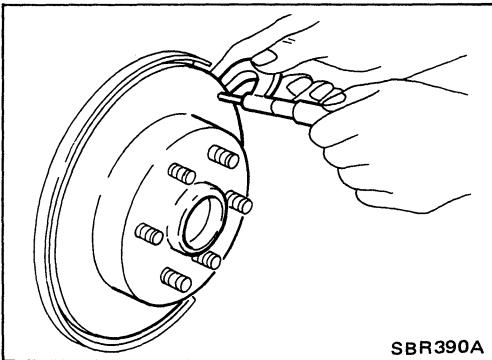

THICKNESS

Rotor repair limit:

Minimum thickness

9.0 mm (0.354 in)

PARKING BRAKE CONTROL

TRUCK-2WD

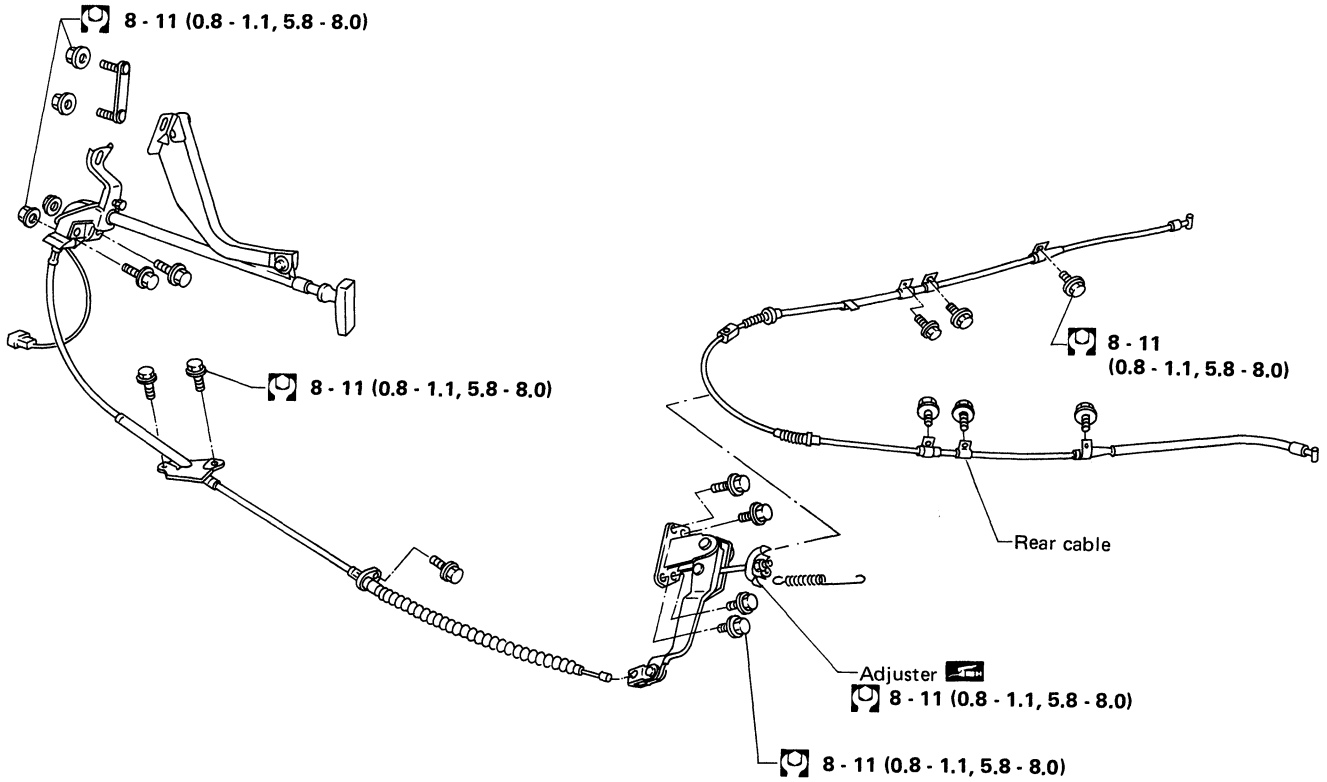

TRUCK-4WD

Stick lever type

8 - 11 (0.8 - 1.1, 5.8 - 8.0)

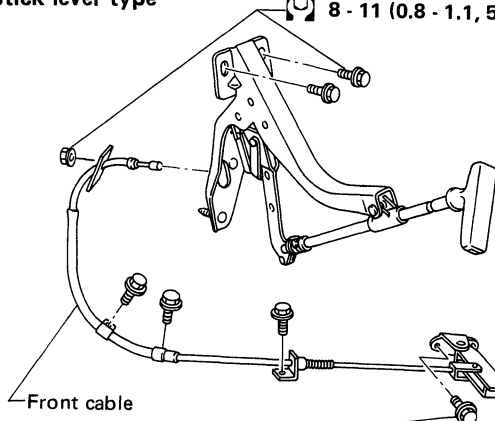

Center lever type

8 - 11 (0.8 - 1.1, 5.8 - 8.0)

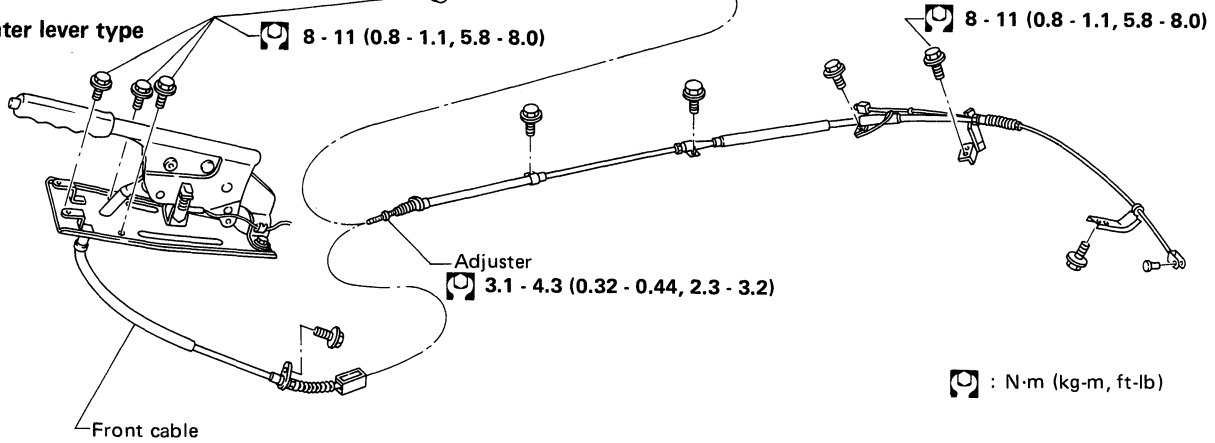

SBR100A

PARKING BRAKE CONTROL

VAN & WAGON

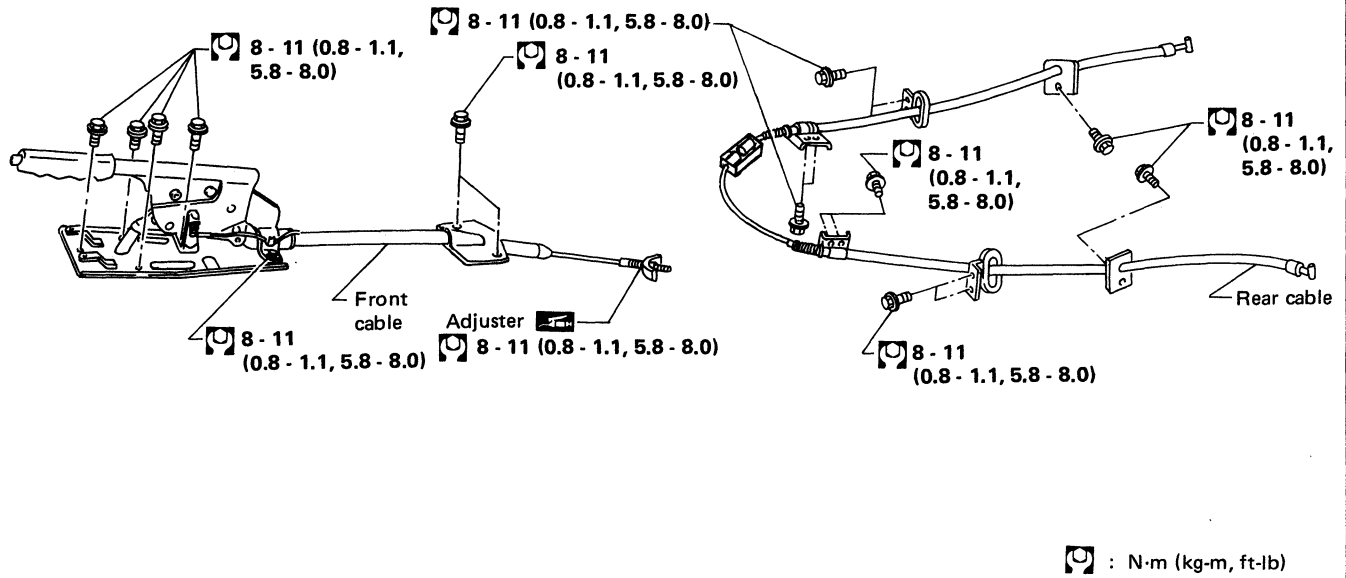

SBR380A

Removal and Installation

- Be careful not to damage cable.
- Make sure there is no free play after installation.

Inspection

1. Check control lever for wear or other damage. Replace if necessary.
2. Check wires for discontinuity or deterioration. Replace if necessary.
3. Check warning lamp and switch. Correct if necessary.
4. Check parts at each connecting portion and, if found deformed or damaged, replace.

Adjustment

Adjust control lever stroke as follows:

PARKING BRAKE CONTROL

Adjustment (Cont'd)

1. Loosen lock nut **(A)** , rotate adjuster **(B)** .
2. Tighten lock nut **(A)** .

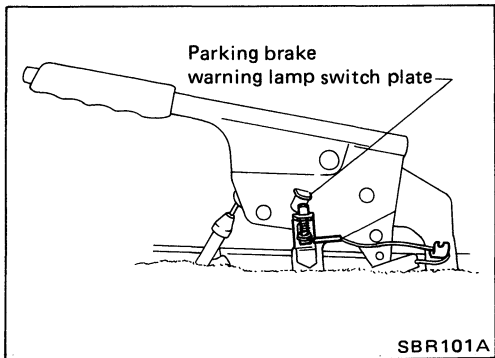
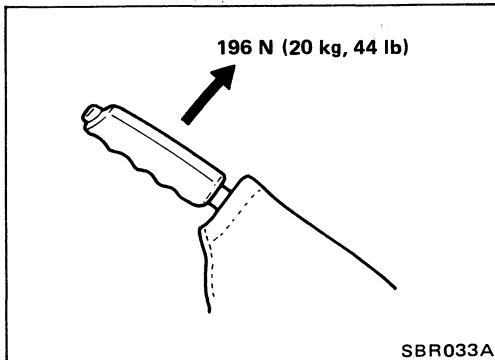
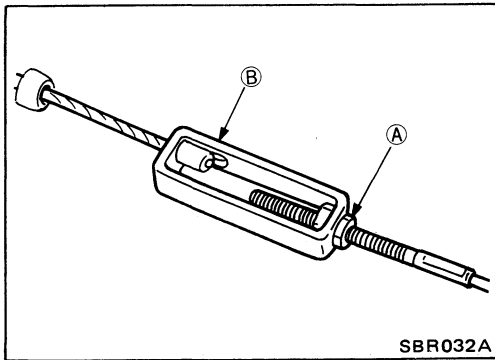

3. Pull control lever with specified amount of force. Check lever stroke and ensure smooth operation.

Number of notches:

Truck

Center lever type	10 - 12
Stick lever type	10 - 12 (2WD) 9 - 11 (4WD)

Van & Wagon

Center lever type	7 - 9
-------------------	-------

4. Bend parking brake warning lamp switch plate so that brake warning light comes on when ratchet at parking brake lever is pulled "A" notches and goes out when fully released.

Number of notches "A":

Truck

Center lever type	1
Stick lever type	2

Van & Wagon

Center lever type	2
-------------------	---

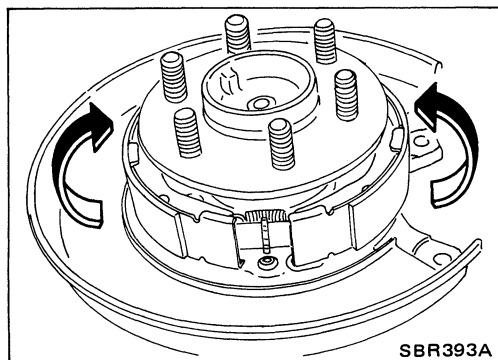
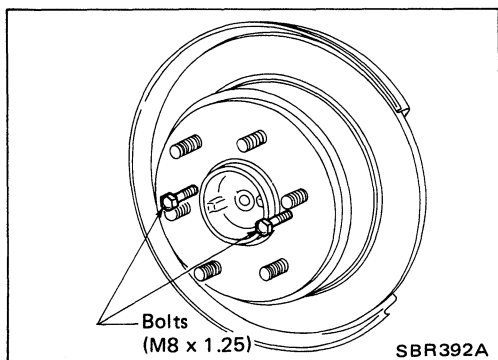
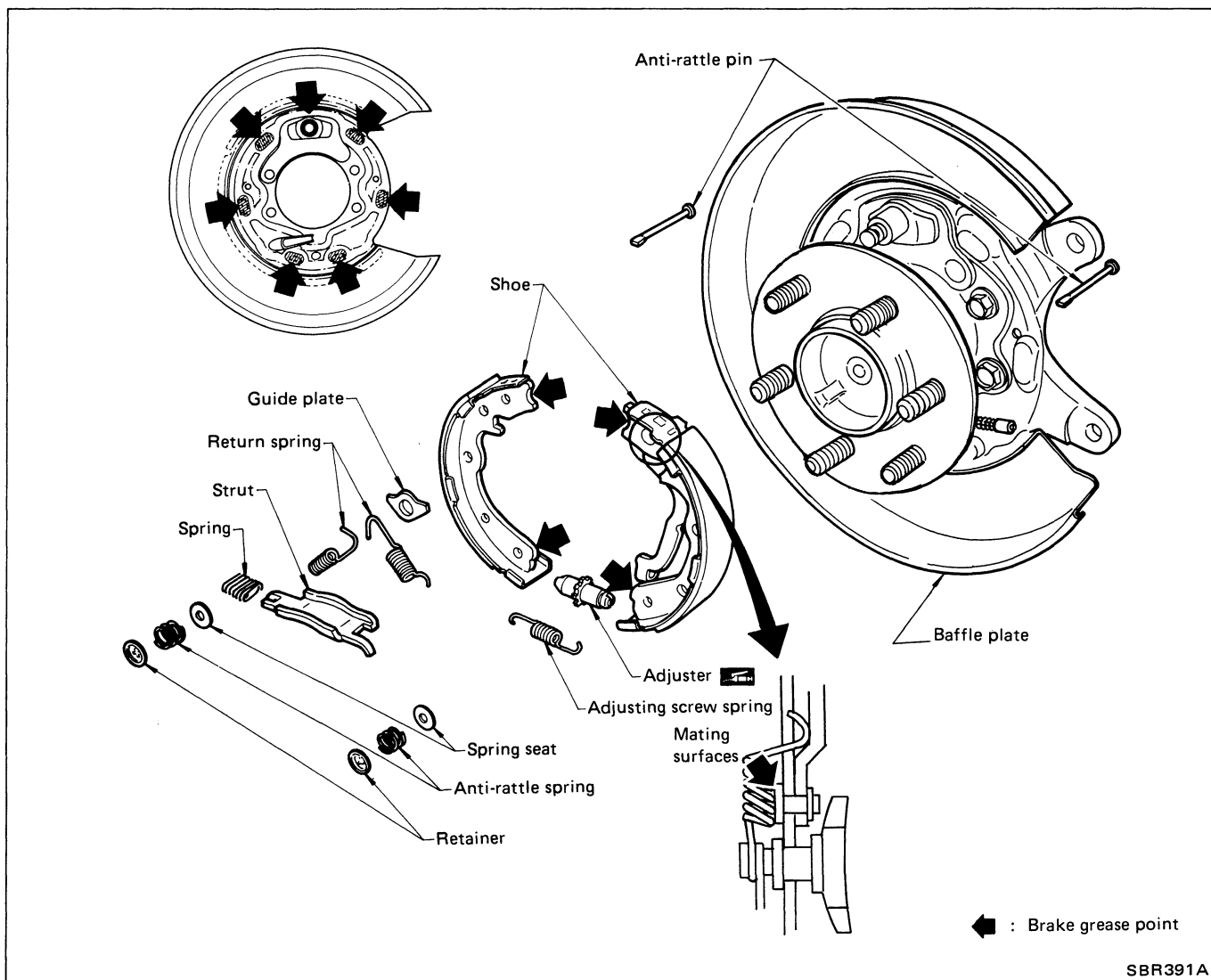

Shoe Replacement

1. Remove disc rotor (With parking drum brake).
Tighten two bolts gradually if disc rotor is hard to remove.
2. After removing retainer, remove spring by rotating shoes.
Be careful not to damage parking brake cable when separating it.

Shoe Replacement (Cont'd)

3. Apply brake grease to the contact areas shown at left.

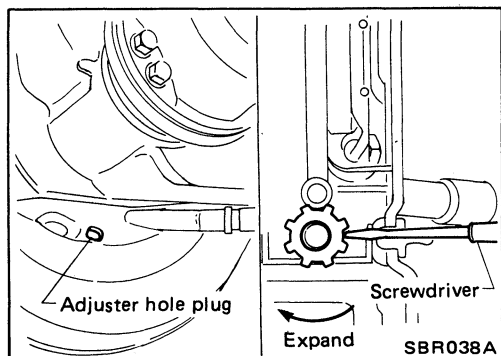
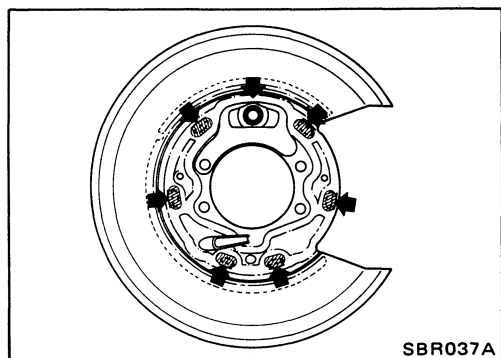

Shoe Clearance Adjustment

1. Remove adjuster hole plug, and turn down adjuster wheel with a screwdriver until shoe touches brake drum.

Make sure that parking control lever is released completely.

2. Return adjuster wheel 7 to 8 latches.
3. Install adjuster hole plug, and make sure that there is no drag between shoes and brake drum when rotating disc rotor.

Breaking in Drum and Lining

1. Set transfer lever in the "2H" position. Using either low or 2nd transmission speed, drive the unloaded vehicle at approximately 30 km/h (19 MPH) on a safe, level and dry road.
2. Depress the release button of parking brake lever, then pull the lever with a force of 98 N (10 kg, 22 lb).
3. While holding the lever back, continue to drive the vehicle 100 m (328 ft).
4. Repeat steps 1 through 3 two or three times.

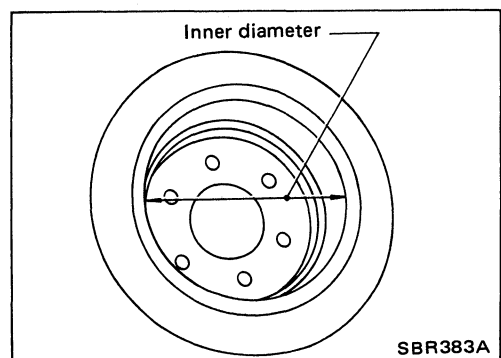

Drum Inspection

Standard inner diameter:

190.0 mm (7.48 in)

Maximum inner diameter:

191.0 mm (7.52 in)

Out-of-roundness (ellipticity):

0.04 mm (0.0016 in)

Radial runout (Total indicator reading):

0.1 mm (0.004 in)

SERVICE DATA AND SPECIFICATIONS (S.D.S.)

General Specifications

	Model	2WD				4WD	4WD and 2WD
	Engine	Z24i		VG30i		VG30i, Z24i	
	Grade	Except STD Regular Bed	STD Regular Bed	Except Heavy Duty Cab & Chassis	Heavy Duty	Truck	Van & Wagon
Front brake							
Brake model		CL28VA		CL28VD			
Pad dimensions Width x thickness x length mm (in)		IN 43 x 11 x 126.5 (1.69 x 0.43 x 4.98) OUT 43 x 11 x 129 (1.69 x 0.43 x 5.08)		48.5 x 10 x 146.6 (1.909 x 0.39 x 5.77)			
Rotor outer diameter	mm (in)	250 (9.84)		260 (10.24)		277 (10.91)	
Cylinder inner diameter	mm (in)	60.6 (2.386)		42.8 (1.685) x 2			
Rear brake							
Brake model		LT26B		DS25B	DS25C	LT26B AD14VB*4 DS19HB*4	
Cylinder inner diameter	mm (in)	22.22 (7/8)		23.81 (15/16)	17.46 (11/16)		20.64 (13/16), 42.83 (1.6862) *4
Lining dimensions Width x thickness x length mm (in)		50 x 5.5 x 249.6 (1.97 x 0.217 x 9.83)		45 x 3.9 x 265.9 (1.77 x 0.154 x 10.47)	60 x 6 x 265.9 (2.36 x 0.24 x 10.47)	50 x 5.5 x 249.6 (1.97 x 0.217 x 9.83), 25.3 x 10 x 100.8 (0.996 x 0.39 x 3.97)*4, 30.0 x 3.0 x 182.3 (1.181 x 0.118 x 7.18)*4	
Drum inner diameter /Rotor outer diameter	mm (in)	260 (10.24)		254 (10.00)		260 (10.24), 286 (11.26)*4, 190 (7.48)*4	
Master cylinder Inner diameter	mm (in)	23.81 (15/16)		25.4 (1)	23.81 (15/16)		
Brake booster							
Model		M20T M195T	G23, M23	M195T, M20T		M195T M215T*4	
Diaphragm diameter	mm (in)	Pri 205 (8.07), 205 (8.07)*5 Sec 180 (7.09), 201 (7.91)*5	230 (9.06)	Pri 205 (8.07), 205 (8.07)*5 Sec 180 (7.09), 201 (7.91)*5		Pri 205 (8.07), 230 (9.06)*4 Sec 201 (7.91), 205 (8.07)*4	
Control valve							
Type		P.V.*3		L.S.V.*1	L.S.V.*2	P.V.*3	
Split point x Reducing ratio kPa (kg/cm ² , psi) x ratio		2,452 (25, 356) x 0.1		(Variable) x 0.1	(Variable) x 0.23	1,961 (20, 284) x 0.1	2,942 (30, 427) x 0.2, 3,923 (40, 569) x 0.4*4

*1: Load sensing valve (A-type)

*2: Load sensing valve (B-type)

*3: Proportioning valve (within master cylinder)

*4: Option as sports package

DS19HB for parking brake

*5: Model M20T type

SERVICE DATA AND SPECIFICATIONS (S.D.S.)

Inspection and Adjustment

BRAKE PEDAL

Model		A/T	M/T
Free height "H"	mm (in)	212 - 222 (8.35 - 8.74)	209 - 219 (8.23 - 8.62)
Depressed height "D" [Under force of 490 N (50 kg, 110 lb) with engine running]	mm (in)	120 (4.72) or more	
Clearance between pedal stopper and threaded end of stop lamp switch "C ₁ "	mm (in)	0.3 - 1.0 (0.012 - 0.039)	
Clearance between pedal stopper and threaded end of A.S.C.D. switch "C ₂ "	mm (in)	0.3 - 1.0 (0.012 - 0.039)	
Pedal free play "A"	mm (in)	1 - 3 (0.04 - 0.12)	

PARKING BRAKE

Type	Center lever type	Stick lever type
Number of notches when warning lamp switch comes on	2*1 2*2	1
Number of notches [When pulled under force of 196 N (20 kg, 44 lb)]	10 - 12*1 7 - 9*2	10 - 12 (2WD)
		9 - 11 (4WD)

*1: Truck model

*2: Van & Wagon model

DISC BRAKE

Brake model	CL28VA	CL28VD	AD14VB
Pad replacement limit Minimum thickness mm (in)	2.0 (0.079)		
Rotor repair limit Maximum runout mm (in)	0.07 (0.0028)		
Minimum thickness mm (in)	20.0 (0.787)	24.0 (0.945)	16.0 (0.630)

DRUM BRAKE

Brake model	DS25B, DS25C	DS22	LT26B	DS19HB
Lining replacement limit Minimum thickness mm (in)	1.5 (0.059)			
Drum repair limit Inner diameter (Max.) mm (in)	255.5 (10.06)	221.5 (8.72)	261.5 (10.30)	191.0 (7.52)
Out-of-round mm (in)	0.03 (0.0012) or less			0.04 (0.0016)
Runout mm (in)	0.05 (0.0020) or less			0.1 (0.004)

SERVICE DATA AND SPECIFICATIONS (S.D.S.)

Tightening Torque

Item	N-m	kg-m	ft-lb	Item	N-m	kg-m	ft-lb
Brake pedal				Crank lever support fixing bolt	19 - 25	1.9 - 2.5	14 - 18
Pedal bracket to body	8 - 11	0.8 - 1.1	5.8 - 8.0	L.S.V. (A-type)			
Stop lamp switch lock nut	12 - 15	1.2 - 1.5	9 - 11	L.S.V. bracket to side member	16 - 22	1.6 - 2.2	12 - 16
Brake booster				L.S.V. mounting bolt	10 - 15	1.0 - 1.5	7 - 11
Brake booster to body	8 - 11	0.8 - 1.1	5.8 - 8.0	Air bleeder	3 - 10	0.3 - 1.0	2.2 - 7.2
Input rod lock nut	16 - 22	1.6 - 2.2	12 - 16	L.S.V. (B-type)			
Brake booster to master cylinder	8 - 11	0.8 - 1.1	5.8 - 8.0	L.S.V. bracket to axle case	17 - 21	1.7 - 2.1	12 - 15
Three-way connector				L.S.V. mounting bolt	17 - 21	1.7 - 2.1	12 - 15
Three-way connector to brake tube	17 - 20	1.7 - 2.0	12 - 14	Air bleeder	6 - 9	0.6 - 0.9	4.3 - 6.5
Three-way connector mounting bolt	5 - 7	0.5 - 0.7	3.6 - 5.1				
Brake tube flare nut	15 - 18	1.5 - 1.8	11 - 13				
Wheel cylinder air bleeder	7 - 9	0.7 - 0.9	5.1 - 6.5				
Front disc brake							
Union bolt	17 - 20	1.7 - 2.0	12 - 14				
Disc rotor to wheel hub	49 - 69	5.0 - 7.0	36 - 51				
Torque member fixing bolt	72 - 97	7.3 - 9.9	53 - 72				
Torque member to cylinder body	22 - 31	2.2 - 3.2	16 - 23				
Baffle plate fixing bolt							
DS22	3.4 - 4.9	0.35 - 0.5	2.5 - 3.6				
DS25B, LT26B, DS25C	6 - 11	0.6 - 1.1	4.3 - 8.0				
Rear drum brake							
Wheel cylinder to back plate	5.3 - 7.3	0.54 - 0.74	3.9 - 5.4				
Rear drum anchor block fixing bolt	50 - 68	5.1 - 6.9	37 - 50				
Back plate fixing							
Single tire model	53 - 63	5.4 - 6.4	39 - 46				
Dual tire model	84 - 108	8.6 - 11.0	62 - 80				
Lock nut of crank lever	2.5 - 4.4	0.25 - 0.45	1.8 - 3.3				
Rear disc brake							
Torque member fixing bolt	54 - 64	5.5 - 6.5	40 - 47				
Torque member to cylinder body	22 - 31	2.2 - 3.2	16 - 23				
Union bolt	17 - 20	1.7 - 2.0	12 - 14				
Parking brake							
Control lever to body							
Center lever type	8 - 11	0.8 - 1.1	5.8 - 8.0				
Stick lever type	8 - 11	0.8 - 1.1	5.8 - 8.0				
Adjuster lock nut							
2WD	8 - 11	0.8 - 1.1	5.8 - 8.0				
4WD (Truck)	3.1 - 4.3	0.32 - 0.44	2.3 - 3.2				
(Van & Wagon)	8 - 11	0.8 - 1.1	5.8 - 8.0				
Front cable clamp to body							
Center lever type	8 - 11	0.8 - 1.1	5.8 - 8.0				
Stick lever type	8 - 11	0.8 - 1.1	5.8 - 8.0				
Parking brake assembly fixing bolt	53 - 63	5.4 - 6.4	39 - 46				

STEERING SYSTEM

SECTION **ST**

CONTENTS

PRECAUTIONS	ST- 2
PREPARATION	ST- 3
DESCRIPTION	ST- 5
ON-VEHICLE INSPECTION	ST- 6
STEERING WHEEL AND STEERING COLUMN	ST-10
MANUAL STEERING GEAR (Model: B56S)	ST-14
POWER STEERING SYSTEM (Model: PB56S)	ST-20
POWER STEERING GEAR (Model: PB56S)	ST-21
POWER STEERING SYSTEM (Model: PB48S)	ST-30
POWER STEERING GEAR (Model: PB48S)	ST-31
POWER STEERING OIL PUMP	ST-37
STEERING LINKAGE	ST-41
SERVICE DATA AND SPECIFICATIONS (S.D.S.)	ST-45



PRECAUTIONS

- Before disassembly, thoroughly clean the outside of the unit.
- Disassembly should be done in a clean work area. It is important to prevent the internal parts from becoming contaminated by dirt or other foreign matter.
- When disassembling parts, be sure to place them in order in parts rack so they can be put back in the unit in their proper positions.
- Use a nylon cloth or paper towel for wiping parts clean. Common shop rags can leave lint that might interfere with the operation.
- All parts should be carefully cleaned with a general purpose, non-flammable solvent before inspection or reassembly.
- Before assembly, apply a coat of recommended A.T.F.* to hydraulic parts. Vaseline may be applied to O-rings and seals. Do not use any grease.
- Gaskets, seals, and O-rings should be replaced. Care should be taken to avoid damaging O-rings, seals and gaskets when assembling. It is also very important to perform functional tests whenever it is designated.

*A.T.F.: Automatic transmission fluid

PREPARATION

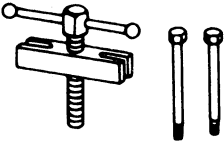
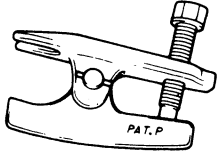
SPECIAL SERVICE TOOLS

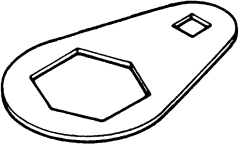
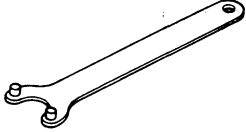
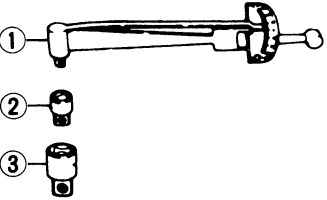
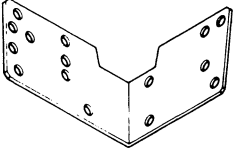
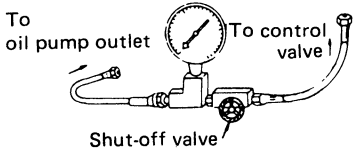
Tool number (Kent-Moore No.) Tool name	Description	Unit application		
		Manual steering	Power steering	
ST27180001 (J25726-A) Steering wheel puller		Removing steering wheel	X	X
HT72520000 (J25730-A) Ball joint remover		Removing ball joint	X	X
ST29020001 (J24319-01) Steering gear arm puller		Removing pitman arm	X	X
KV48101500 (J28802) Lock nut wrench			X	-
KV48101400 (J28803) Adjusting plug wrench		Adjusting and tightening lock nut	X	-
ST3127S000 (See J25765-A) ① GG91030000 (J25765-A) Torque wrench ② HT62940000 (-) Socket adapter ③ HT62900000 (-) Socket adapter		Measuring turning torque	X	X
KV48100301 (-) Strut & steering gearbox attachment		Steering gear is installed.	X	X
ST27091000 (J26357) Pressure gauge		Measuring oil pressure	-	X

PREPARATION

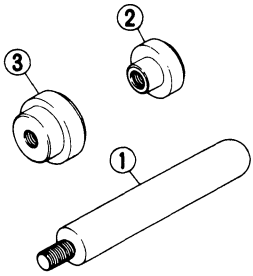
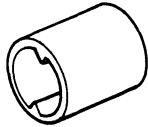
Tool number (Kent-Moore No.) Tool name	Description	Unit application	
		Manual steering	Power steering
KV481009S0 (-) Oil seal drift set ① KV48100910 (-) Drift ② KV48100920 (J26367) Adapter ③ KV48100930 (J26367) Adapter	Installing oil seal 	-	X
KV48100700 (J26364) Torque adapter	Adjusting worm bearing preload 	X	X

COMMERCIAL SERVICE TOOL

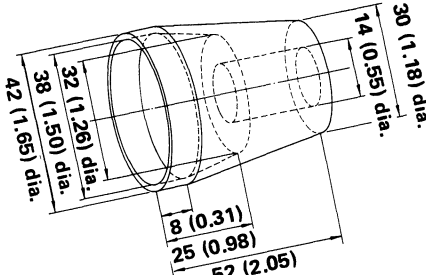
Tool name	Description	Unit application	
		Manual steering	Power steering
Boot band attachment	Installing boot band  <p style="text-align: right;">Unit: mm (in) SST671A</p>	X	X

DESCRIPTION

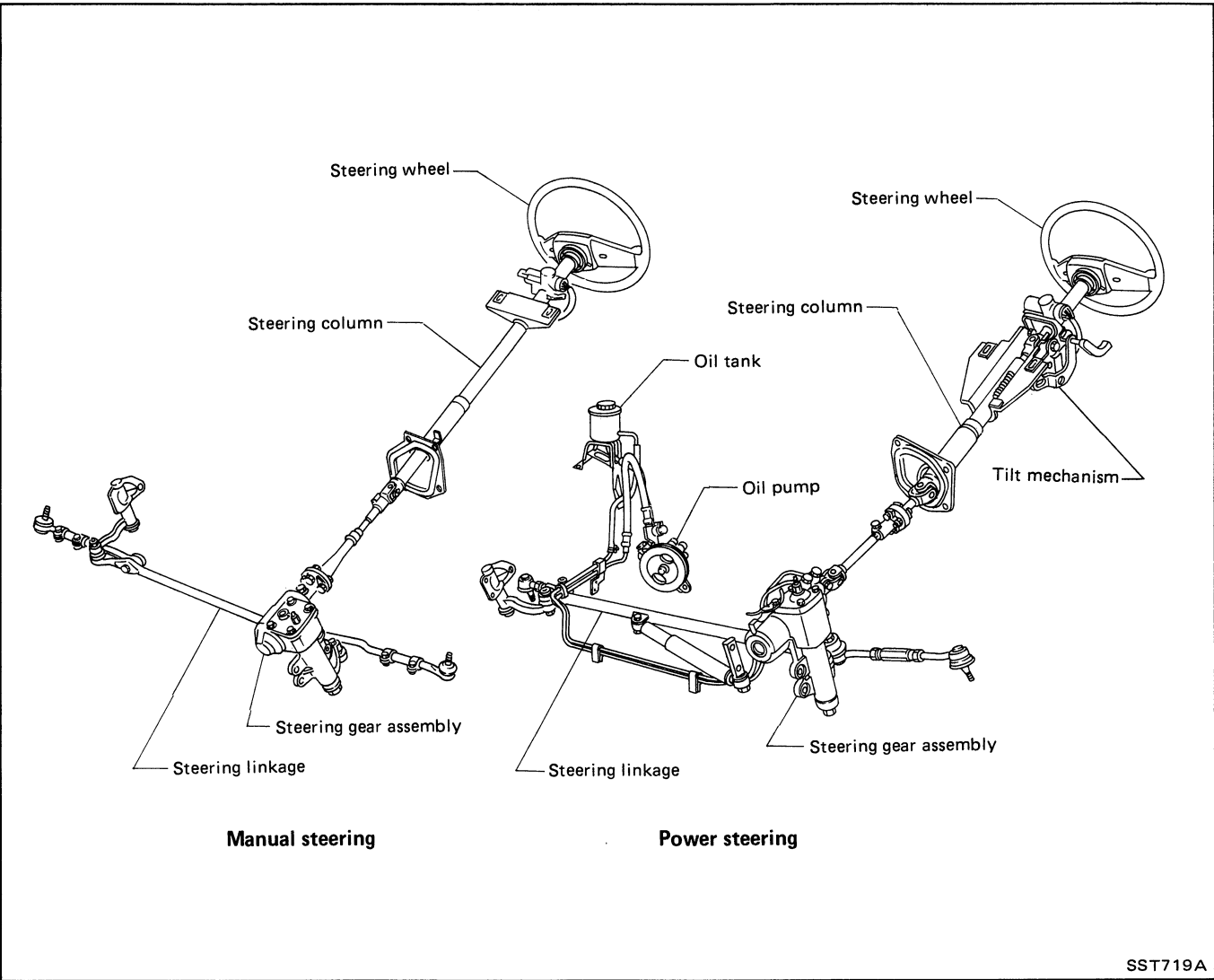

ON-VEHICLE INSPECTION

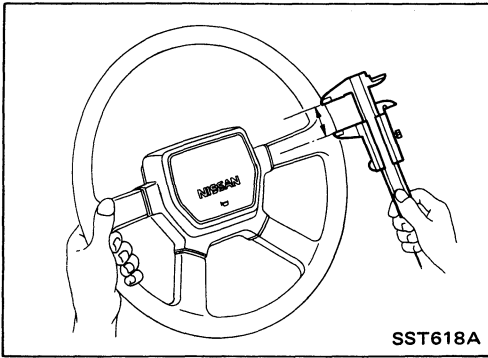

Checking Steering Wheel Play

- With wheels in a straight ahead position and check steering wheel play.

Steering wheel play:

35 mm (1.38 in) or less

- If it is not within specification, check backlash of steering gear, tie-rod outer and inner ball joints.

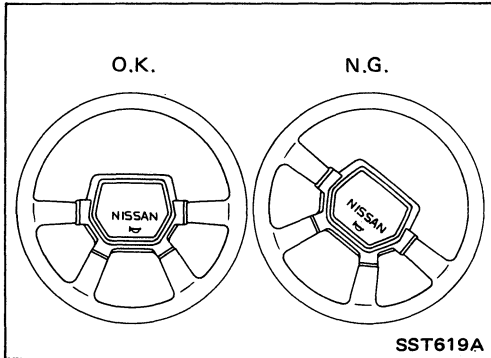

Checking Neutral Position on Steering Wheel

Pre-checking

- Verify that the steering gear is centered before removing the steering wheel.

Checking

- Check that the steering wheel is in the neutral position when driving straight-ahead.
- If it is not in the neutral position, remove the steering wheel and reinstall it correctly in the neutral position.
- If the neutral position is between two serrated teeth, loosen tie-rod lock nut and move tie-rod in the opposite direction by the same amount on both left and right sides to compensate for error in the neutral position.

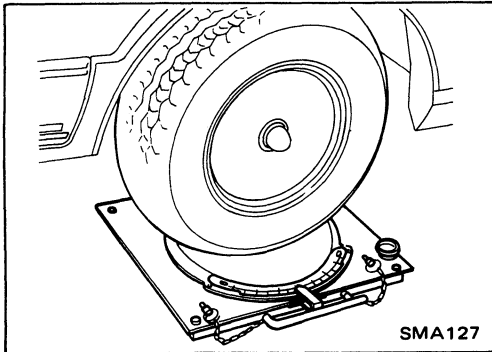

Checking Front Wheel Turning Angle

- Rotate steering wheel all the way right and left; measure turning angle.

Turning angle:

Full turns and toe-out turn

Refer to section FA for S.D.S.

Checking and Adjusting Drive Belts (Power steering)

- Refer to section MA for Drive Belt Inspection.

ON-VEHICLE INSPECTION

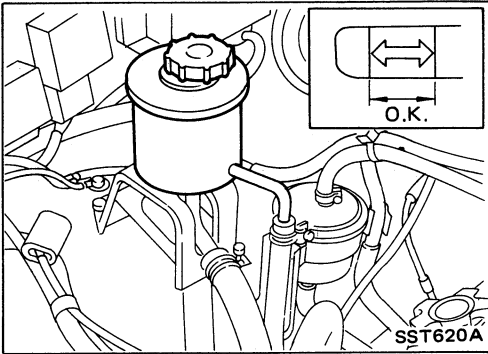

Checking Fluid Level (Power steering)

Check the fluid level when the fluid is cold.

CAUTION:

- Do not overfill.
- Recommended fluid is Automatic Transmission Fluid "Dexron Type".

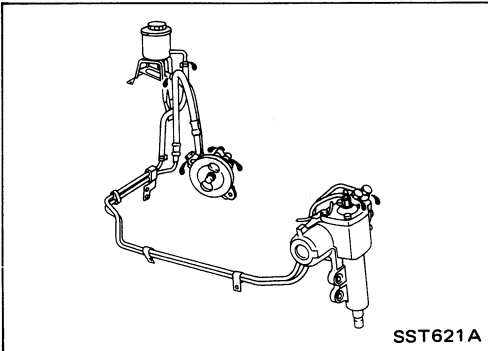

Checking Fluid Leakage (Power steering)

Check lines for proper attachment, leaks, cracks, damage, loose connections, chafing and deterioration.

1. Run engine at idle speed or 1,000 rpm.
Make sure temperature of fluid in oil tank rises to 60 to 80°C (140 to 176°F).
2. Turn steering wheel right-to-left several times.
3. Hold steering wheel at each "lock" position for five seconds and carefully check for fluid leakage.

CAUTION:

Do not hold steering wheel at lock position for more than fifteen seconds at a time.

4. If fluid leakage at connectors is noticed, loosen flare nut and then retighten.

Do not overtighten connector as this can damage O-ring, washer and connector.

Bleeding Hydraulic System (Power steering)

1. Raise front end of vehicle until wheels clear ground.
2. While adding fluid, quickly turn steering wheel fully to right and left until it lightly touches steering stoppers.

CAUTION:

Do not hold steering wheel in lock position for more than fifteen seconds.

Repeat steering wheel operation until fluid level no longer decreases.

3. Start engine.

Repeat step 2 above.

- Incomplete air bleeding will cause the following to occur. When this happens, bleed air again.
 - ① Generation of air bubbles in reservoir tank
 - ② Generation of clicking noise in oil pump
 - ③ Excessive buzzing in oil pump

ON-VEHICLE INSPECTION

Bleeding Hydraulic System (Power steering) (Cont'd)

In steering while the vehicle is stationary, or when moving wheel slowly, fluid noise may be caused in the valve or oil pump. This type of fluid noise is inherent in an integral power steering system, and it will not affect performance or durability of the system.

Checking Steering Wheel Turning Torque (Power steering)

1. Park vehicle on a level, dry surface and set parking brake.
2. Bring power steering fluid up to adequate operating temperature. [Make sure temperature of fluid is approximately 60 to 80°C (140 to 176°F)].

Tires need to be inflated to normal pressure.

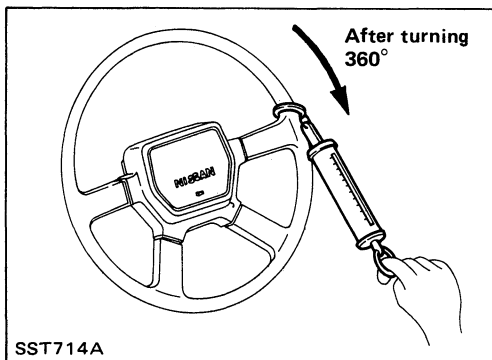

3. Check steering wheel turning force when steering wheel has been turned 360° from neutral position.

Steering wheel turning force:

PB48S-type

24.5 - 29.4 N (2.5 - 3.0 kg, 5.5 - 6.6 lb)

PB56S-type

39 N (4 kg, 9 lb) or less

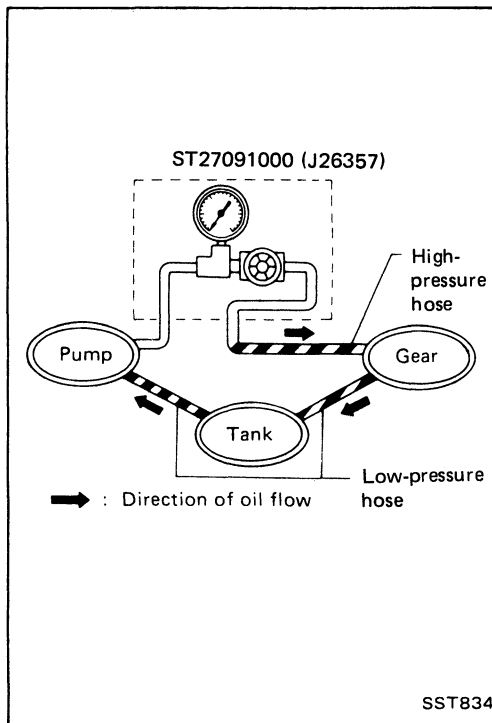

Checking Hydraulic System (Power steering)

Before starting, check belt tension, driving pulley and tire pressure.

1. Set Tool. Open shut-off valve. Then bleed air. (See "Bleeding Hydraulic System".)
2. Run engine.
Make sure temperature of fluid in tank rises to 60 to 80°C (140 to 176°F).

WARNING:

Warm up engine with shut-off valve fully opened. If engine is started with shut-off valve closed, oil pressure in oil pump will increase to relief pressure, resulting in an abnormal rise in oil temperature.

3. Check pressure with steering wheel fully turned to left and right positions.

ON-VEHICLE INSPECTION

Checking Hydraulic System (Power steering) (Cont'd)

CAUTION:

Do not hold steering wheel at lock position for more than fifteen seconds.

Oil pump standard pressure:

7,649 - 8,238 kPa

(78 - 84 kg/cm² , 1,109 - 1,194 psi) at idling

4. If oil pressure is below the standard, slowly close shut-off valve and check pressure.
 - When pressure becomes standard, gear is damaged.
 - When pressure remains beyond standard, pump is damaged.
5. If oil pressure is higher than the standard level, pump is damaged.

CAUTION:

Do not close shut-off valve for more than fifteen seconds.

6. After checking hydraulic system, remove Tool and add fluid as necessary, then completely bleed air out of system.

STEERING WHEEL AND STEERING COLUMN

Removal and Installation

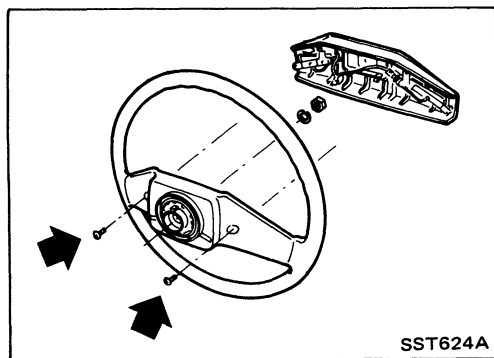
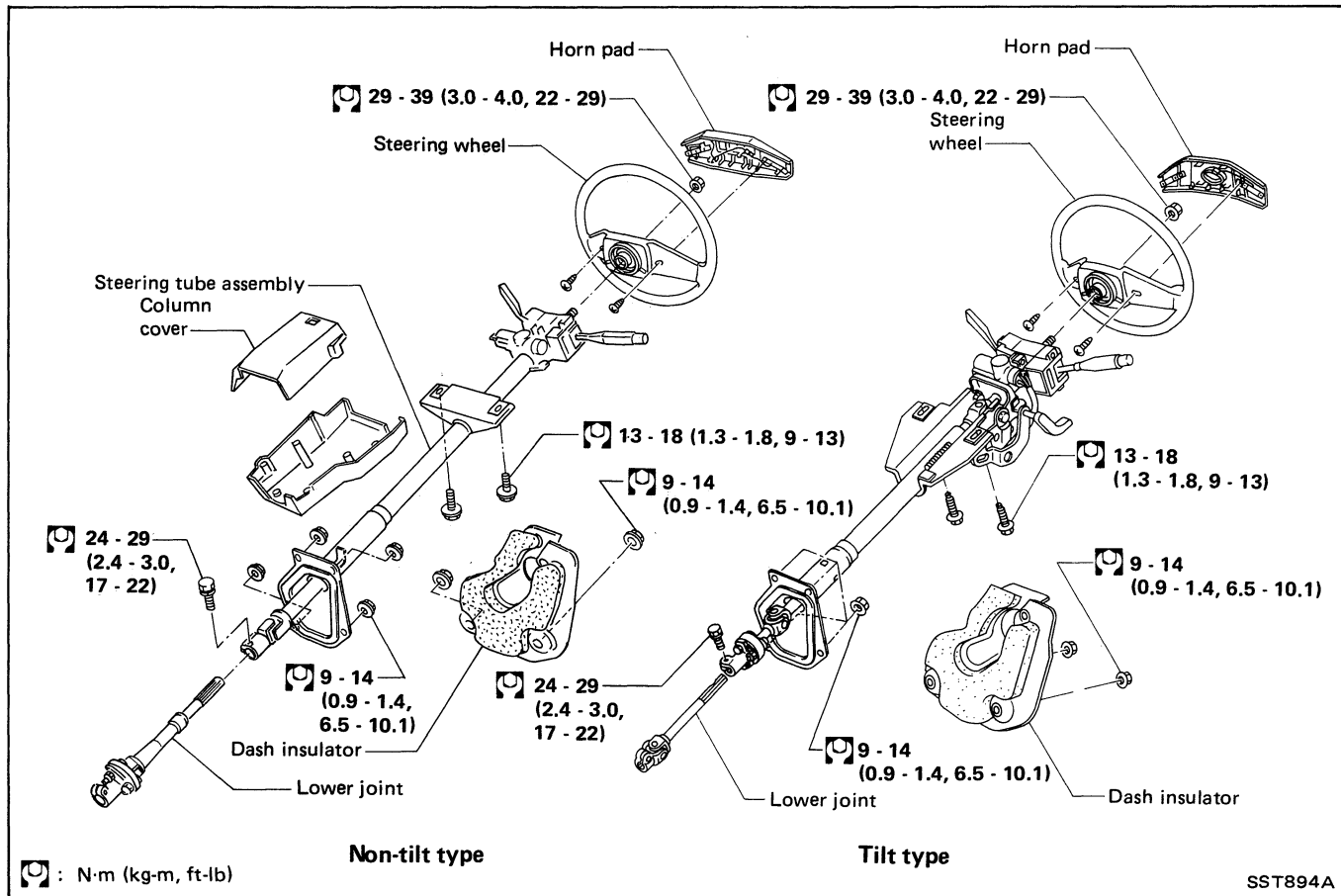

STEERING WHEEL

- Remove two screws from the rear of steering wheel.

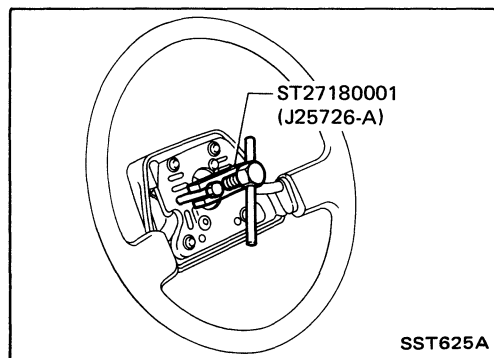

- Remove steering wheel with Tool.

STEERING WHEEL AND STEERING COLUMN

Removal and Installation (Cont'd)

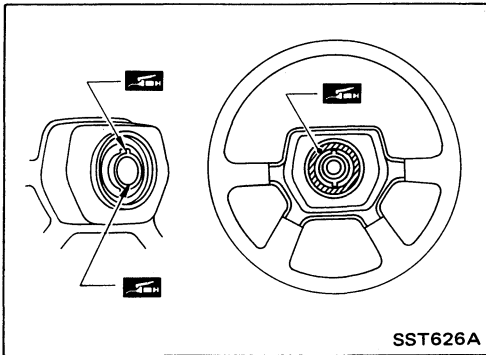

- When installing steering wheel, apply multi-purpose grease to entire surface of turn signal cancel pin (both portions) and also to horn contact slip ring.

- Install steering wheel on column shaft in a straight-ahead position.
- After installing, turn steering wheel to make sure it moves smoothly and that the number of turns from the straight forward position to left and right locks are equal.

STEERING COLUMN

- When installing steering column, finger-tighten all lower bracket and clamp retaining bolts; then retighten them securely. Make sure that undue stress is not applied to steering column.

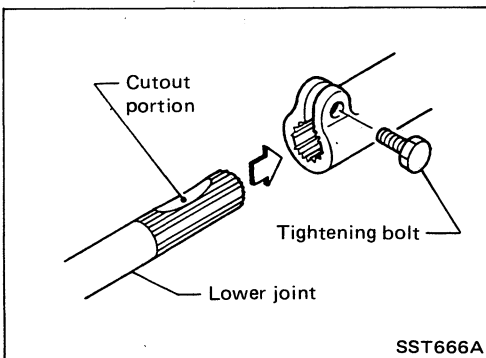

- When fitting steering lower joint, be sure tightening bolt faces cutout portion perfectly.

STEERING WHEEL AND STEERING COLUMN

Disassembly and Assembly

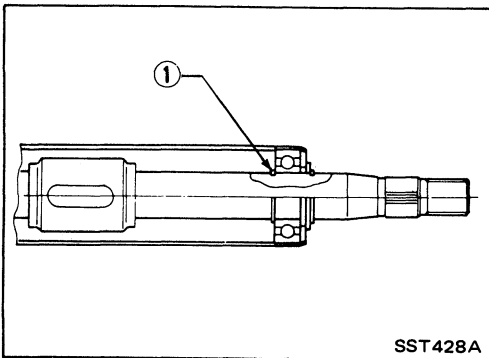
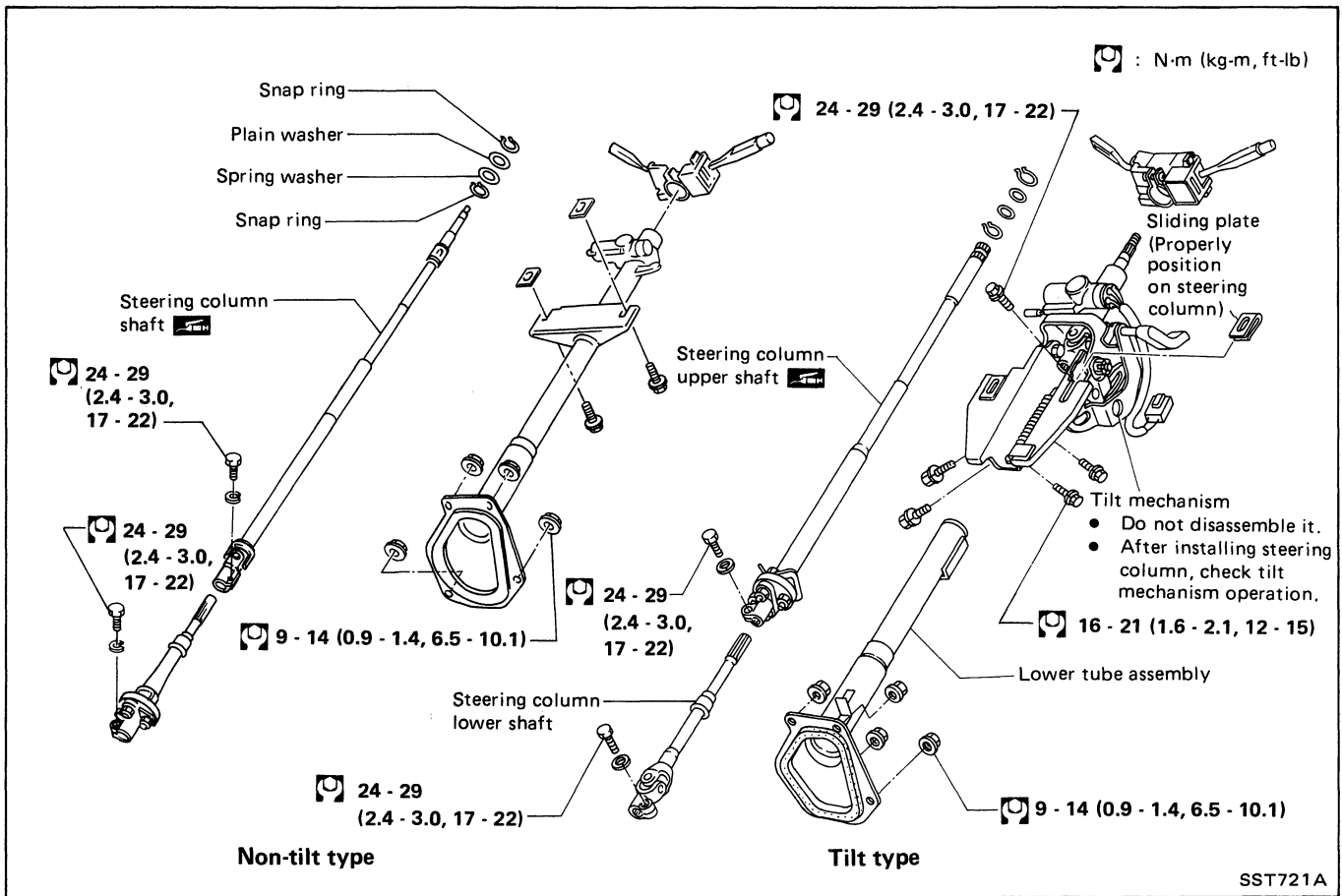

- When disassembling and assembling, unlock steering lock with key.
- Ensure that rounded surface of snap ring faces toward bearing when snap ring is installed.
- Install snap ring ① before inserting shaft into jacket tube.

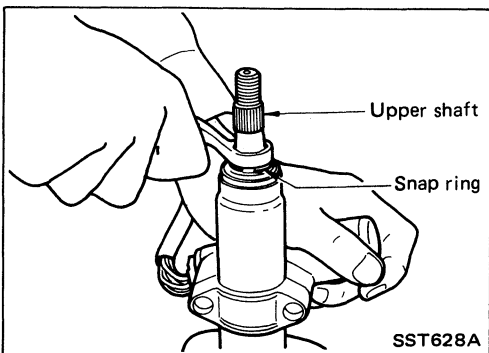

- Install snap ring on upper shaft with tool.

STEERING WHEEL AND STEERING COLUMN

Disassembly and Assembly (Cont'd)

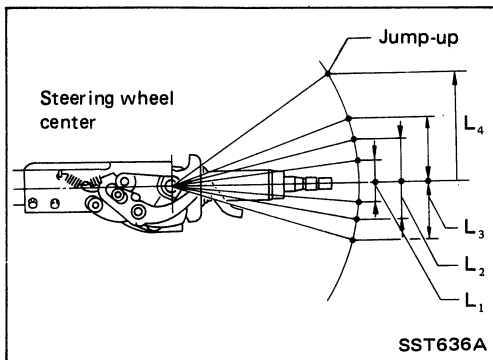

- Tilt type
After installing steering column, check tilt mechanism operation.

L ₁	:	8.7 mm (0.343 in)
L ₂	:	17.3 mm (0.681 in)
L ₃	:	26.0 mm (1.024 in)
L ₄	:	100.0 mm (3.937 in)

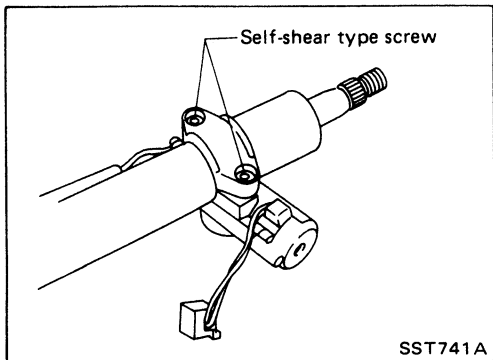

- Steering lock
a) Break self-shear type screws with a drill or other appropriate tool.

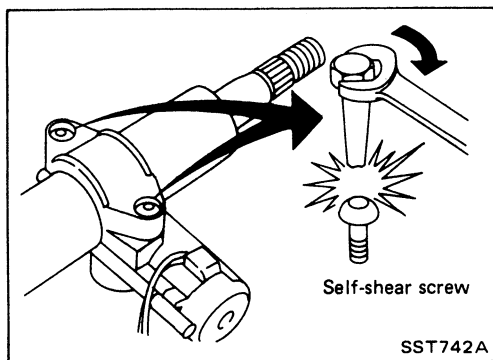

- b) Install self-shear type screws and then cut off self-shear type screw heads.

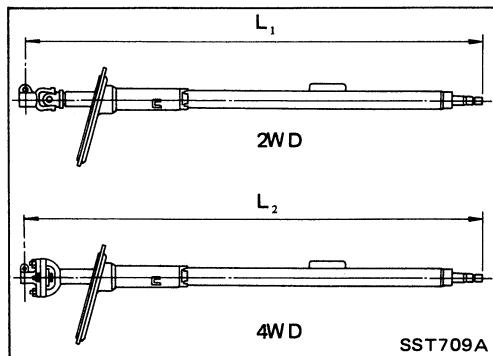

Inspection

- When steering wheel can not be rotated smoothly, check the steering column for the following matters and replace damaged parts.
 - (1) Check column bearings for damage or unevenness. Lubricate with recommended multi-purpose grease or replace steering column as an assembly, if necessary.
 - (2) Check jacket tube for deformation or breakage. Replace if necessary.
- When the vehicle is involved in a light collision, check dimension "L". If it is not within specifications, replace steering column as an assembly.

Column length "L₁ & L₂":

L ₁	=	918.0 - 919.6 mm (36.14 - 36.20 in)
L ₂	=	886.1 - 887.7 mm (34.89 - 34.95 in)

MANUAL STEERING GEAR (Model : B56S)

Removal and Installation

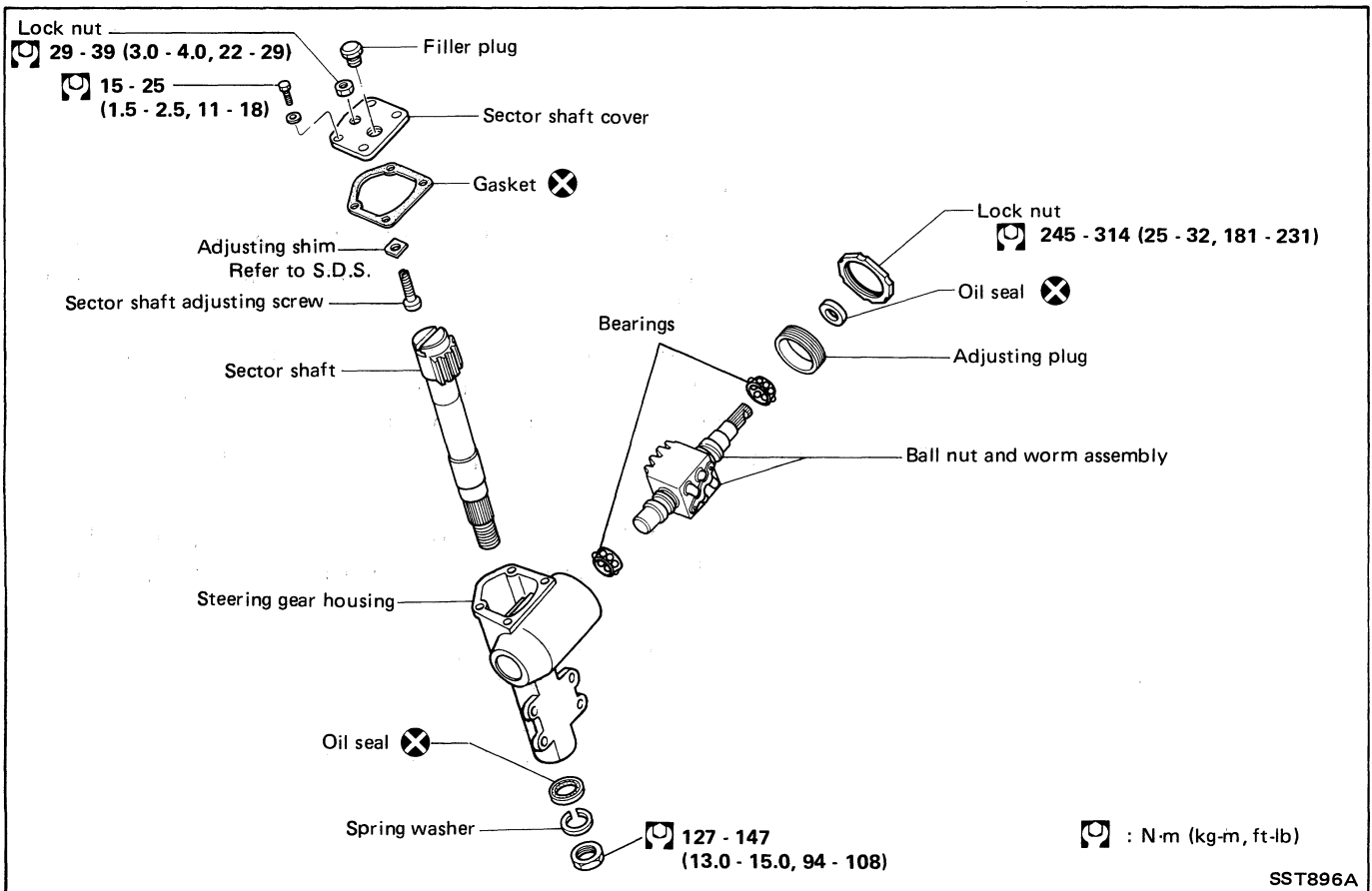
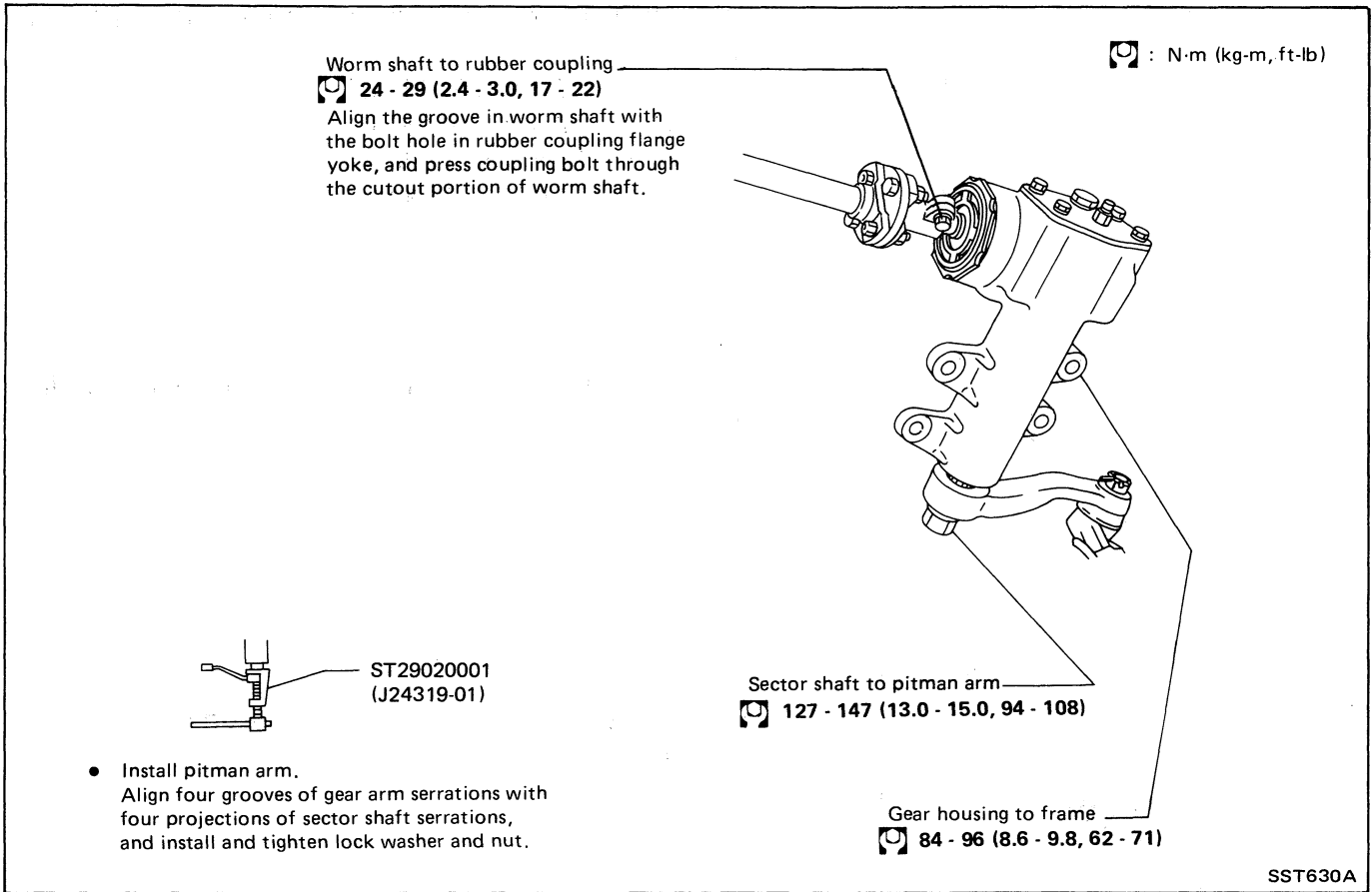

MANUAL STEERING GEAR (Model : B56S)

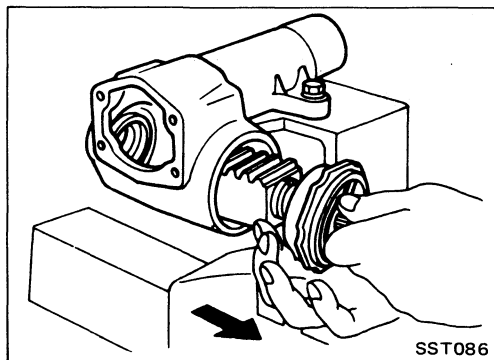
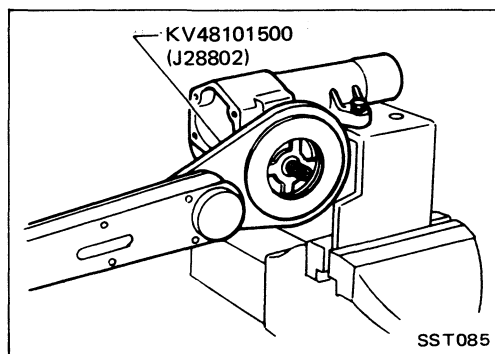
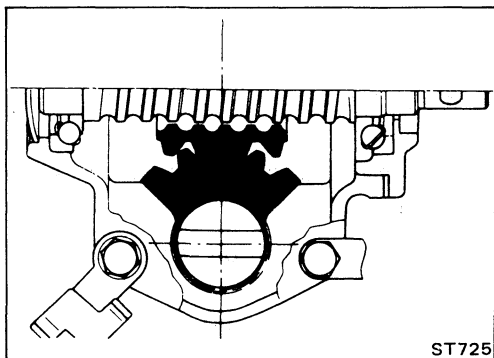
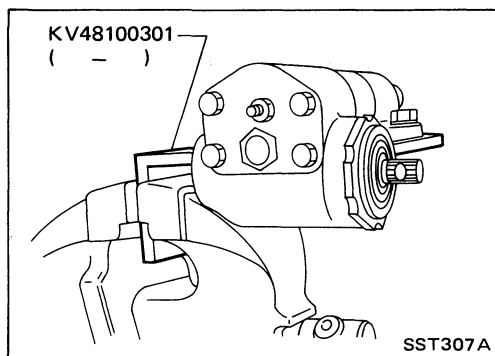

Disassembly

1. Place steering gear in a vise with Tool.

2. Set worm gear in a straight-ahead position.

3. Remove sector shaft with sector shaft cover.

CAUTION:

- When pulling sector shaft out, be careful not to damage oil seal or associated parts.
- Set worm gear in a straight-ahead position.
- Do not remove sector shaft needle bearings from steering gear housing. If necessary, replace gear housing assembly.

4. Loosen adjusting plug lock nut with Tool.

5. Draw out worm gear with worm bearing.

CAUTION:

- Be careful not to allow ball nut to run down to either end of worm.
Ends of ball guides will be damaged if nut is rotated until it stops at end of worm.
- Do not detach ball nut from worm shaft assembly.
If necessary, replace entire unit as an assembly.
- Do not remove sector shaft needle bearings from steering gear housing.
If necessary, replace entire gear housing as an assembly.

MANUAL STEERING GEAR (Model : B56S)

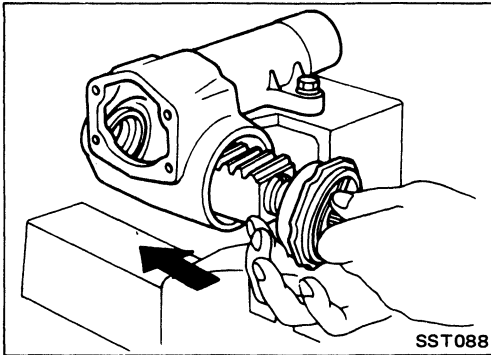

Assembly and Adjustment

Fill space between sealing lips of new sector shaft and adjusting plug oil seals with multi-purpose grease.

WORM BEARING PRELOAD

1. Fit worm gear assembly with worm bearing in gear housing.

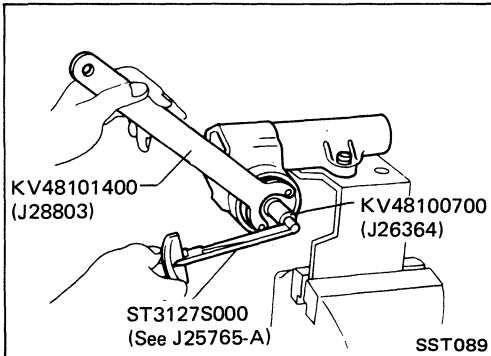

2. Adjust worm bearing preload with Tools.

CAUTION:

- Always adjust worm bearing preload by turning adjusting plug in "tighten" direction.
- Rotate worm shaft a few turns in both directions to settle down worm bearing and measure preload.

Worm bearing preload (without oil seal):

0.20 - 0.59 N·m

(2.0 - 6.0 kg-cm, 1.7 - 5.2 in-lb)

3. Apply suitable sealant around lock nut inner surface.

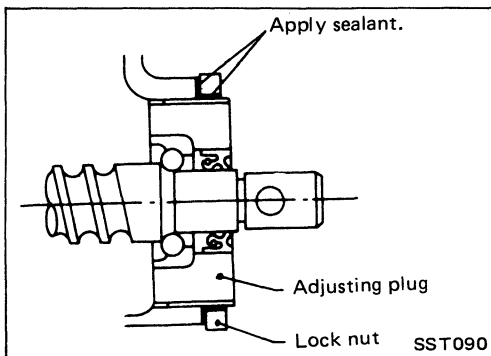

4. Tighten lock nut using Tools.

5. After tightening lock nut, check worm bearing preload to make sure it is within specification.

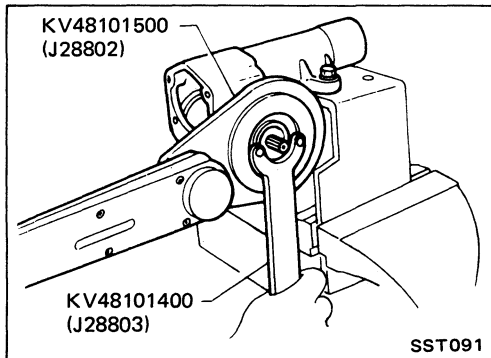

MANUAL STEERING GEAR (Model : B56S)

Assembly and Adjustment (Cont'd)

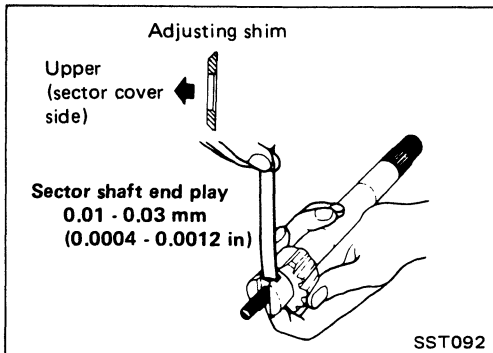
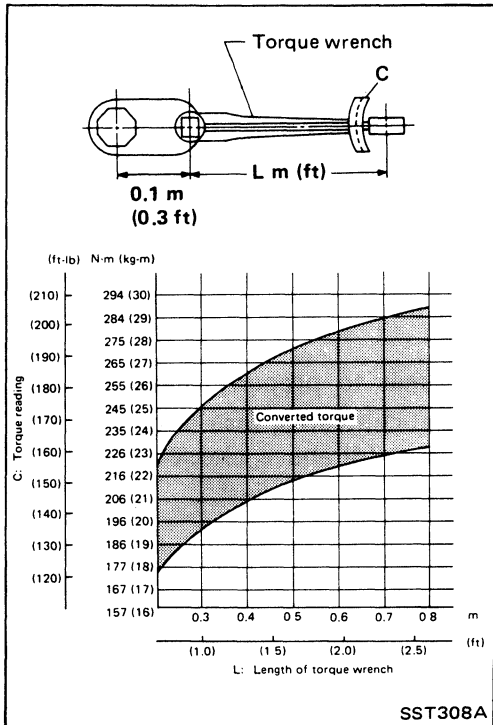

SECTOR SHAFT END PLAY

Select suitable adjusting shim and adjust end play between sector shaft and adjusting screw.

Sector shaft end play:

0.01 - 0.03 mm (0.0004 - 0.0012 in)

Sector shaft adjusting screw shims:

Refer to S.D.S.

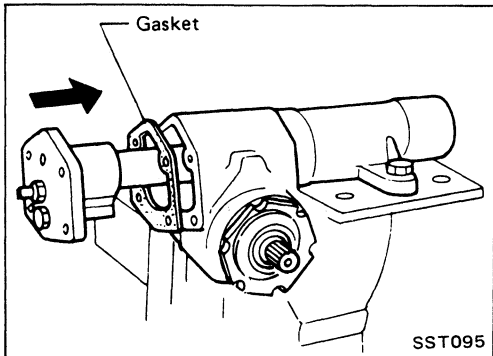

STEERING GEAR PRELOAD AND BACKLASH

1. Set worm gear in a straight-ahead position.

Carefully insert sector shaft in place, using care not to scratch oil seal.

2. Adjust adjusting screw until sector shaft just contacts ball nut. Temporarily tighten lock nut.

3. Lubricate contacting portion of sector shaft and ball nut with gear oil or bearing grease.

4. Tighten adjusting screw further to increase worm gear preload, and lock with lock nut.

Preload increment:

0.2 - 0.4 N-m (2 - 4 kg-cm, 1.7 - 3.5 in.-lb)

CAUTION:

- Always adjust steering gear preload by turning adjusting screw in "tighten" direction.
- Rotate worm gear a few turns in both directions to settle down steering gear.

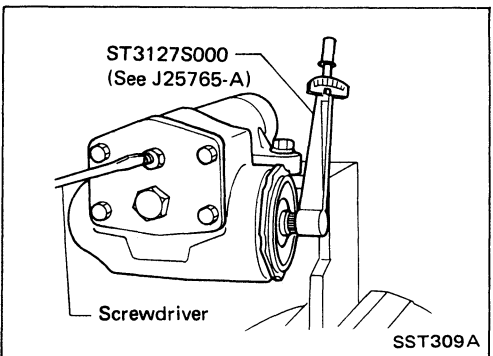

MANUAL STEERING GEAR (Model : B56S)

Assembly and Adjustment (Cont'd)

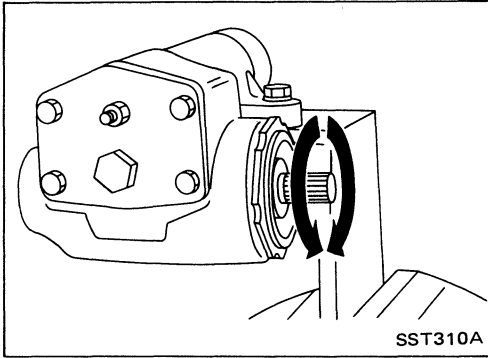

5. Turn worm gear several times by hand to properly break in worm bearing.
6. Check steering gear preload. If not within specification, readjust it.

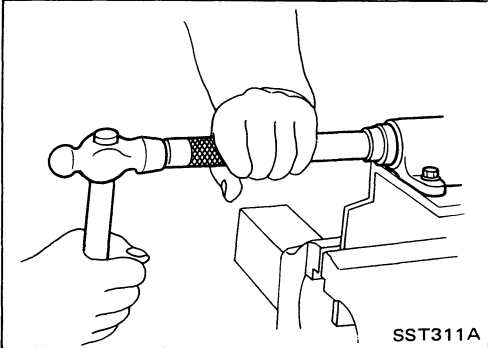

7. Drive oil seal into place.
Before pressing oil seal, coat seal contacting face of oil seal with gear fluid.

8. Measure total preload.

Steering gear total preload (with oil seals):

New parts

0.83 - 1.23 N·m

(8.5 - 12.5 kg·cm, 7.4 - 10.9 in·lb)

Used parts

0.59 - 0.98 N·m

(6.0 - 10.0 kg·cm, 5.2 - 8.7 in·lb)

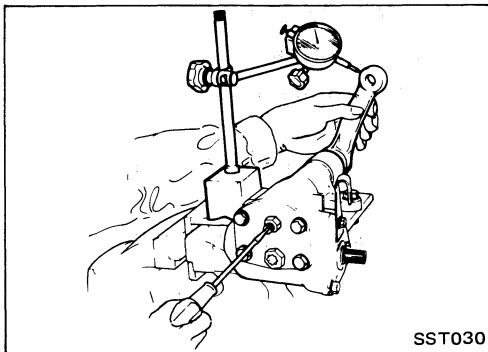

9. Check backlash.
Measure backlash at pitman arm top end in straight-ahead position.

Backlash (in straight-ahead position):

New gear: 0.1 mm (0.004 in) or less

Used gear: 0.3 mm (0.012 in) or less

Inspection

Wash clean all the disassembled parts in solvent and check for condition.

SECTOR SHAFT

1. Check gear tooth surface for pitting, burrs, cracks or any other damage, and replace if necessary.
2. Check sector shaft for distortion on its serration, and replace if necessary. Also check gear housing for deformation.

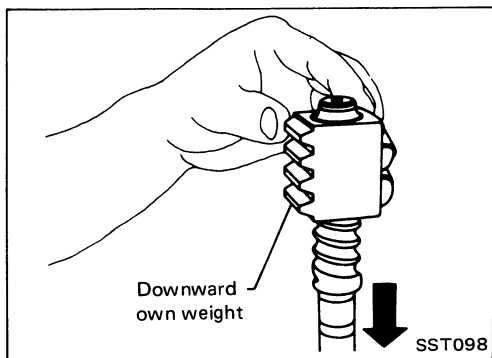

Inspection (Cont'd)

STEERING WORM ASSEMBLY

1. Inspect ball nut gear tooth surface, and replace if pitting, burrs, wear or any other damage is found.
2. Ball nut must rotate smoothly on worm gear. If found too tight, assembly should be replaced. Check rotation of ball nut as follows:
 - (1) Move ball nut to either end of worm gear, and gradually stand worm shaft and ball nut assembly until ball nut moves downward on worm gear under its own weight.
 - (2) If ball nut does not move freely over entire stroke, replace assembly.

Be careful not to damage ball nut guide tube while check is being made.

CAUTION:

Be careful not to allow ball nut to run down to either end of worm.

BEARING

1. Inspect worm bearing for wear, pitting or any other damage. Replace as required.

When replacing worm bearing, replace it as a set of bearing and outer race.

2. If sector shaft needle bearings are worn or damaged, replace as an assembly of gear housing and bearings.

OIL SEALS

- Discard any oil seal which has once been removed.
- Replace oil seal if sealing lip is deformed or cracked.
- Discard oil seal if spring is fatigued or dislocated.

POWER STEERING SYSTEM (Model : PB56S)

Description

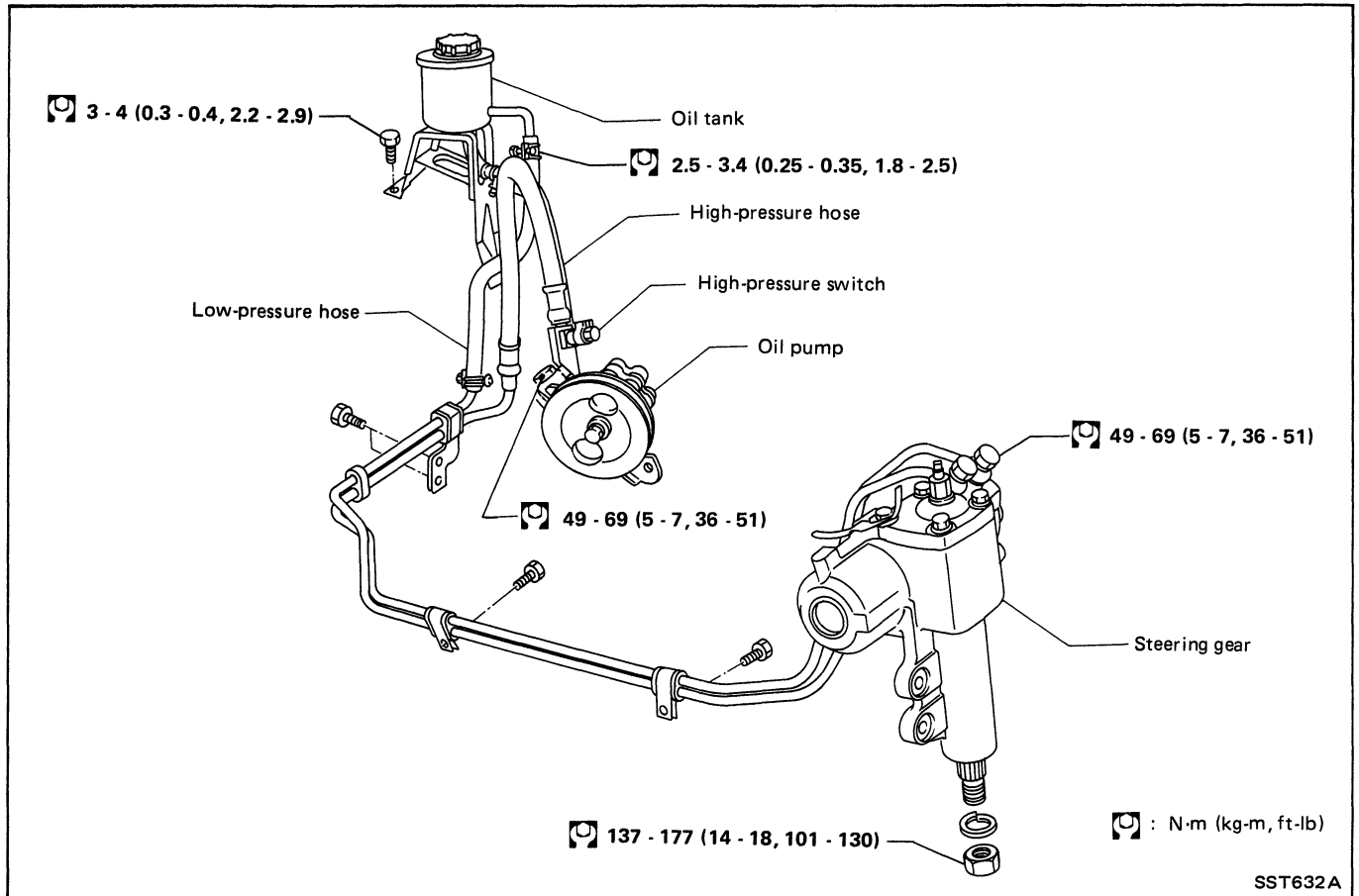

This power steering adopts spool valve control which was developed in a technical tie-up with the ZF Company.

Only the sealing parts can be replaced. The remaining parts must be replaced as an assembly.

CAUTION:

- The parts which can be disassembled are strongly restricted, and never disassemble other parts than the specified ones.
- Disassembly should be performed in a place as clean as possible.
- Hands should be cleaned before disassembly.
- Do not use a rag. Be sure to use nylon or paper cloth.
- Be sure to follow procedures and cautions indicated in the Service Manual.

POWER STEERING GEAR (Model : PB56S)

Removal

Before removing, clean exteriors or gear housing and oil pump with steam and dry with compressed air.

STEERING GEAR

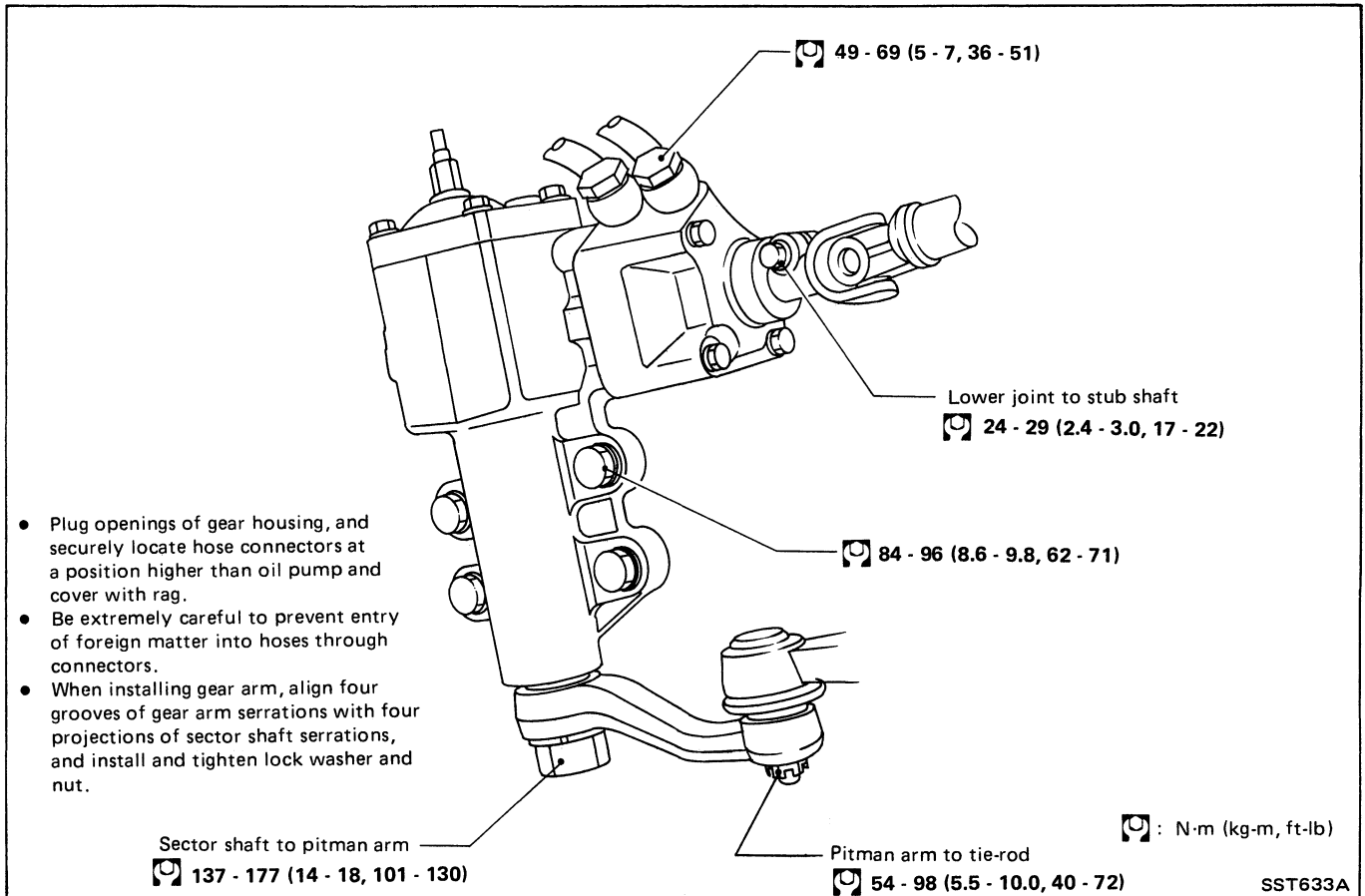

POWER STEERING GEAR (Model : PB56S)

Power Steering Gear Component

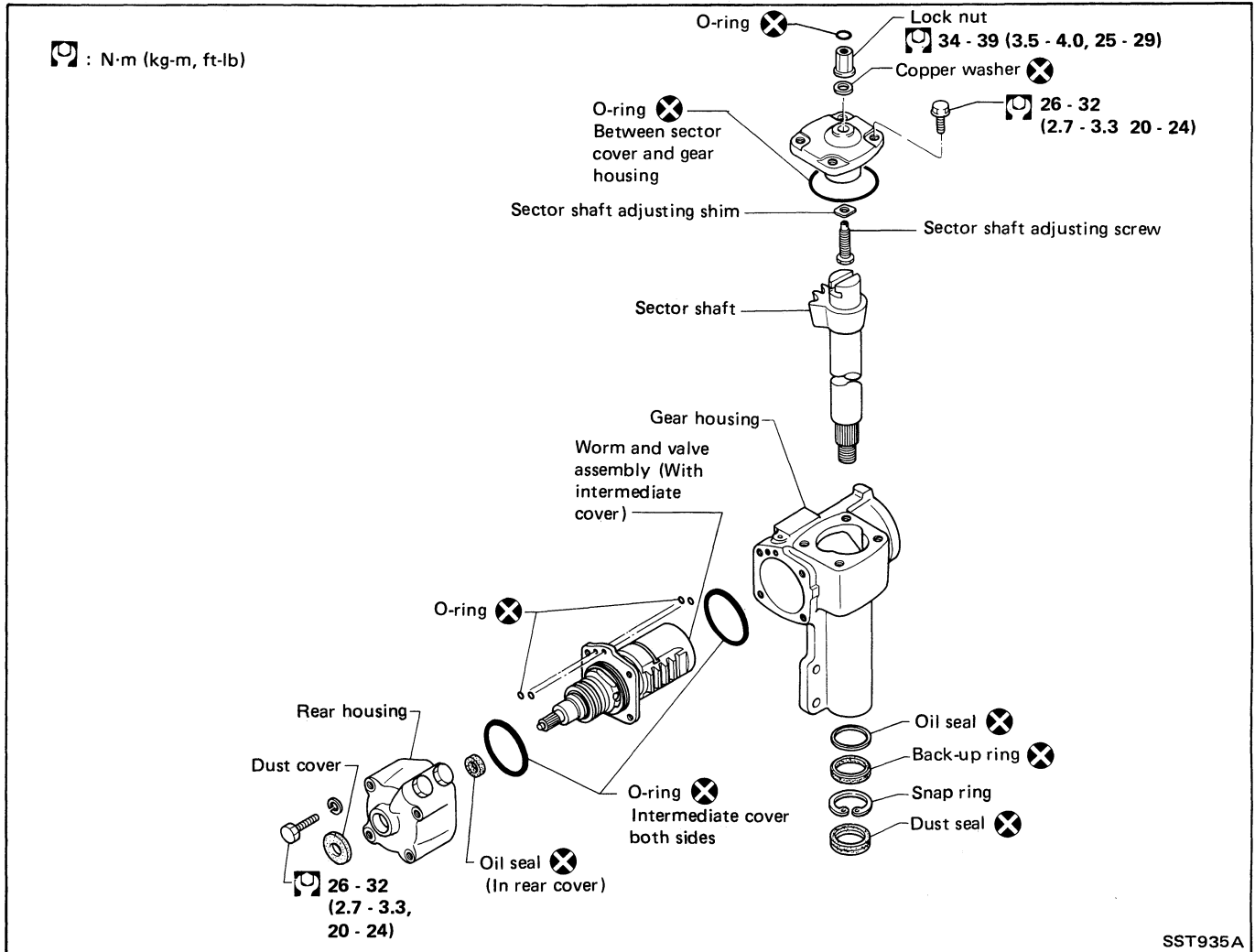

Inspection and Adjustment

Before disassembling power steering gear component parts, make sure there is no oil leakage around sealing portion and check steering turning torque as follows:

Check sealing portion.

- Adjusting screw nut O-ring
- Sector shaft cover O-ring
- Sector shaft oil seal
- Rear cover oil seal and O-ring
- Rear housing O-ring
- Gear housing O-ring

Discard any oil seal and O-ring which have once been removed. Replace oil seal and O-ring if sealing surface is deformed or cracked.

POWER STEERING GEAR (Model : PB56S)

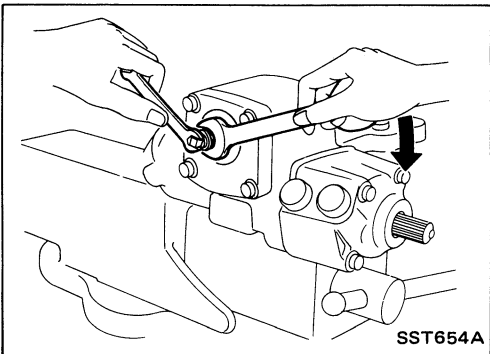
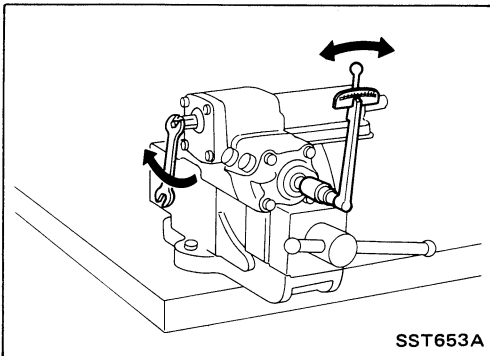
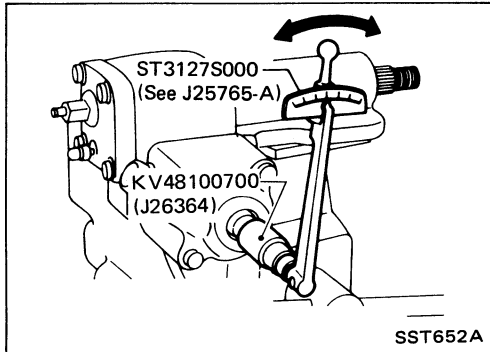
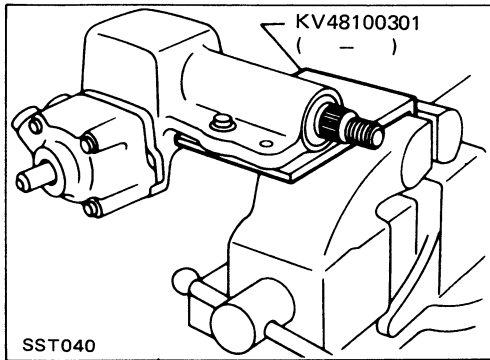

Inspection and Adjustment (Cont'd)

TURNING TORQUE MEASUREMENT

1. Measure turning torque at 360° position.

(1) Install steering gear on Tool.

(2) Turn stub shaft all the way to right and left several times.

(3) Measure turning torque at 360° position from straight-ahead position with Tools.

Turning torque at 360° :

0.7 - 1.2 N·m

(7 - 12 kg·cm, 6.1 - 10.4 in·lb)

(4) Measure turning torque at straight-ahead position.

Straight-ahead position is a position where stub shaft is turned 2.14 turns (two full turns and 50°) from lock position.

Turning torque at straight-ahead position:

0.1 - 0.4 N·m

(1 - 4 kg·cm, 0.9 - 3.5 in·lb) higher than at 360°

If they are not within specifications, adjust turning torque by turning sector shaft adjusting screw.

2. Tighten adjusting screw lock nut with tools.

Disassembly

Before disassembly, measure turning torque.

If they are not within specifications, replace steering gear assembly.

CAUTION:

Each oil sealing parts, dust cover, copper washer and snap ring once removed must not be used again.

POWER STEERING GEAR (Model : PB56S)

Disassembly (Cont'd)

ADJUSTING SCREW LOCK NUT O-RING

Remove adjusting screw lock nut, and replace O-ring.

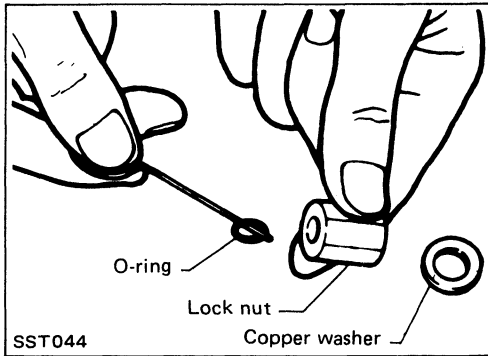

SECTOR SHAFT OIL SEAL AND DUST SEAL

1. Set stub shaft in a straight-ahead position.

Straight-ahead position is a position where stub shaft is turned 2.14 turns (two full turns and 50°) from lock position.

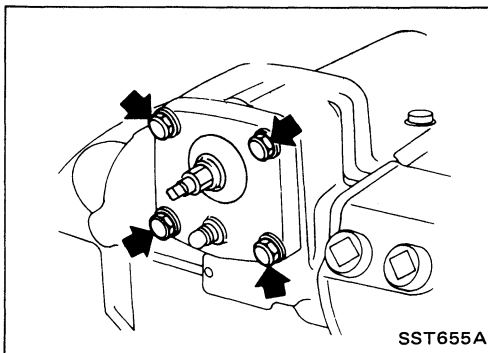

2. Disconnect sector shaft cover bolt.

Do not turn lock nut unless necessary; otherwise it will damage O-ring, resulting in an oil leak.

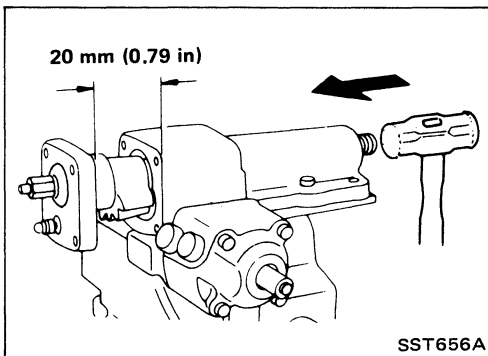

3. Draw out sector shaft.

Knock out end of sector shaft approximately 20 mm (0.79 in).

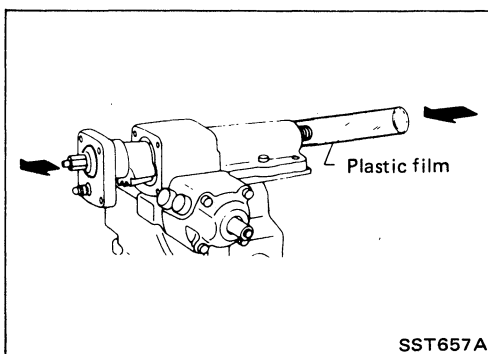

4. Connect a roll of plastic film to sector shaft.

Plastic film:

Thickness 0.1 mm (0.004 in)

Length x width

200 x 200 mm (7.87 x 7.87 in)

5. Pull out sector shaft by hand.

Attach plastic film to needle bearings located at two places inside gear housing while simultaneously pulling out sector shaft so that bearings will not drop into housing.

POWER STEERING GEAR (Model : PB56S)

Disassembly (Cont'd)

6. Remove gear housing dust seal.
7. Remove snap ring.

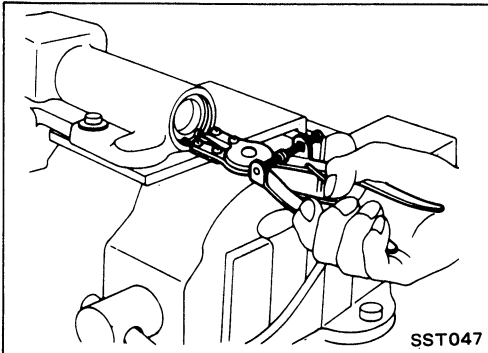

8. Remove back-up ring and oil seal.
9. Remove O-ring.

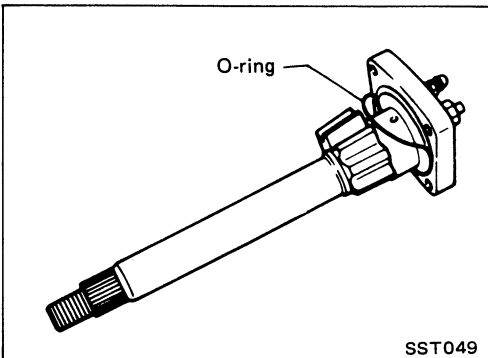

REAR HOUSING O-RING

1. Remove sector shaft.
2. Loosen (do not remove) rear housing bolts.

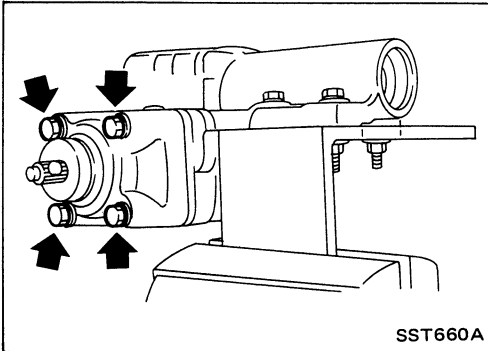

3. Turn stub shaft counterclockwise slightly to raise intermediate cover through piston.

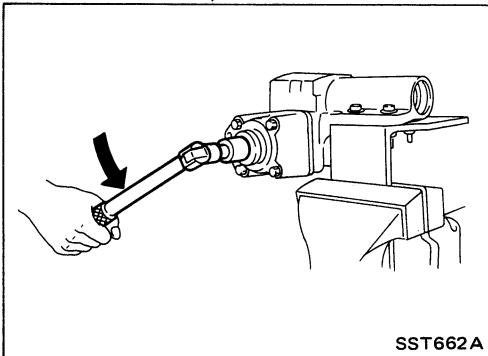

4. Remove rear housing together with worm gear assembly.

CAUTION:

- a. When worm assembly is removed, piston may turn and come off under its own weight. Hold piston to prevent it from turning.

If piston-to-rear housing clearance exceeds 35 mm (1.38 in) by loosening, recirculating ball will be out of groove of worm; do not reinstall piston but replace the entire assembly.

- b. Take care not to damage teflon ring at piston end when removing.

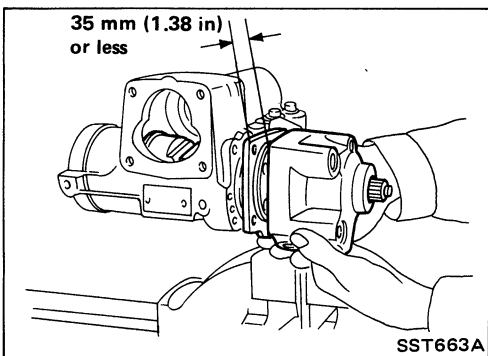

POWER STEERING GEAR (Model : PB56S)

Disassembly (Cont'd)

5. Remove rear housing, turn worm assembly upside down, and lightly tap stub shaft end on top of workbench.

CAUTION:

- Do not strike shaft with a hammer or pry it with a screwdriver.
- Do not disassemble worm and valve.

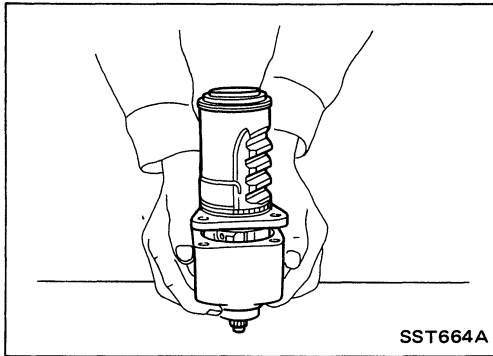

6. Remove rear housing oil seal with tool.

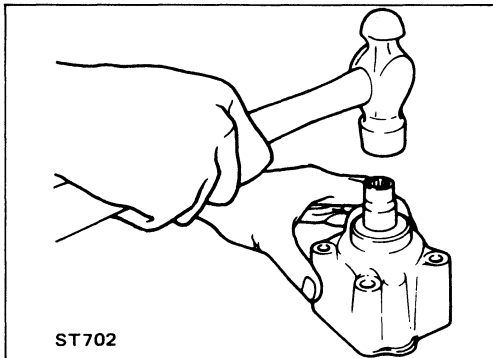

7. Remove O-ring on both sides of intermediate cover.

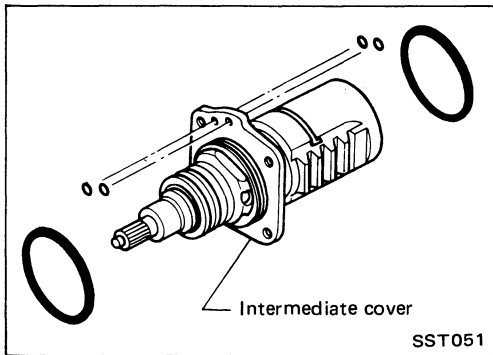

Assembly

Rear housing seal and intermediate cover (between worm and valve)

1. Install new rear housing oil seal with Tool.
Before installing oil seal, apply multi-purpose grease to lips.

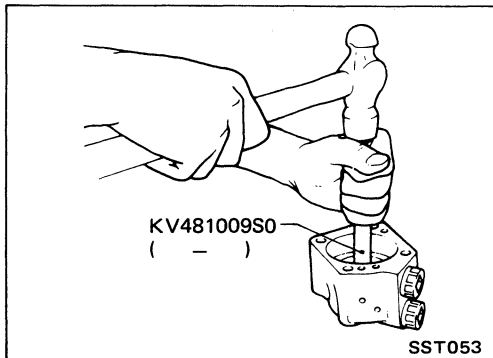

2. Install new O-rings on both sides of intermediate cover.
 - Apply a thin coat of vaseline to new O-rings prior to their installation.
 - Be careful not to install wrong O-rings as some of them resemble in size.

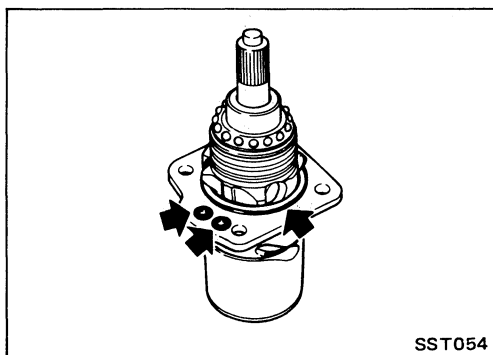

POWER STEERING GEAR (Model : PB56S)

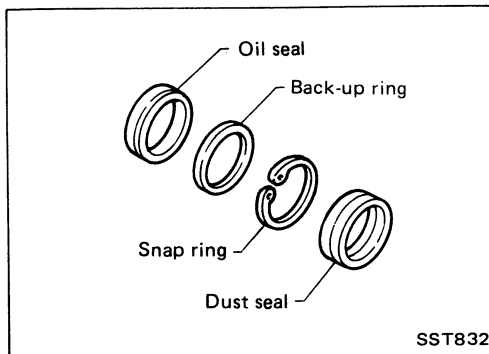
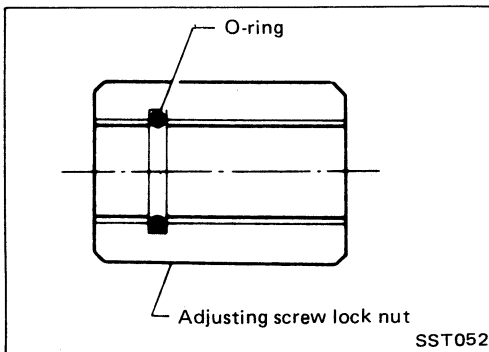
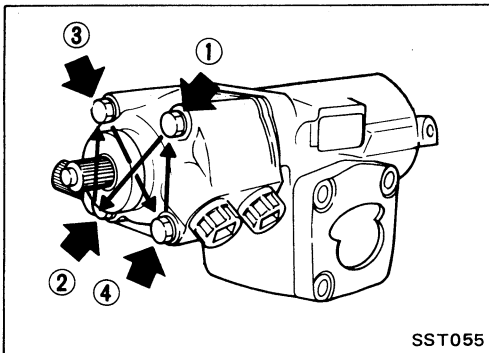
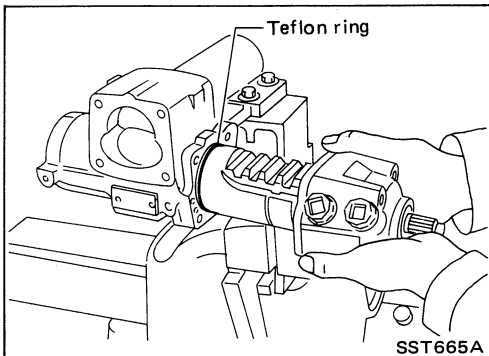
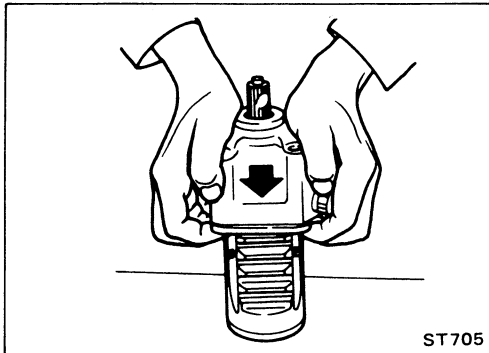

Assembly (Cont'd)

3. Fit rear housing onto intermediate cover with worm gear assembly.

CAUTION:

- Do not tilt ball bearing on rear cover side.
- Make sure that O-rings are not protruding or extruding.
- Be careful not to separate worm and stub shaft.
- Wrap vinyl tape around serration of stub shaft to prevent oil seal lip from being damaged during insertion.

4. Install worm gear assembly with rear housing and intermediate cover into gear housing.

CAUTION:

- Apply a thin coat of A.T.F. inside gear housing and piston before insertion.
- Be sure that teflon ring at piston end is not damaged during insertion of gear housing. If it is damaged, replace entire assembly.
- Be sure that teflon ring settles in its correct position.

5. Gradually tighten rear housing bolts in a criss-cross fashion.

ADJUSTING SCREW LOCK NUT O-RING

Insert new O-ring into adjusting screw lock nut.

- Before inserting, apply a thin coat of vaseline to O-ring.
- Insert O-ring to make sure it fits into groove.

SECTOR SHAFT OIL SEAL

- When installing, be sure to use new oil seal, dust seal, back-up ring and snap ring.
- Before installing, apply a thin coat of vaseline to new oil seal and dust seal.

POWER STEERING GEAR (Model : PB56S)

Assembly (Cont'd)

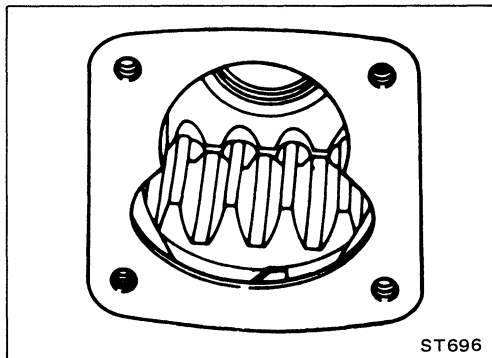
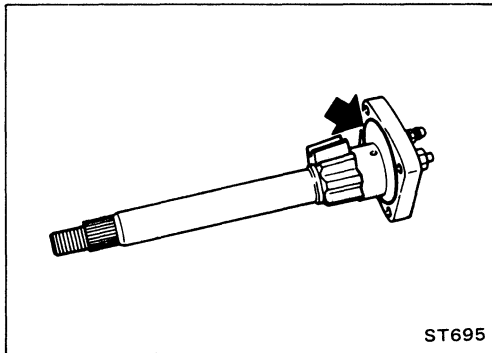
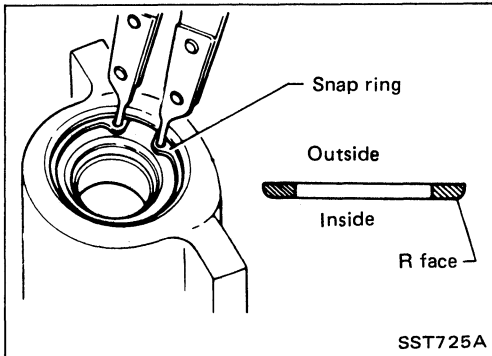
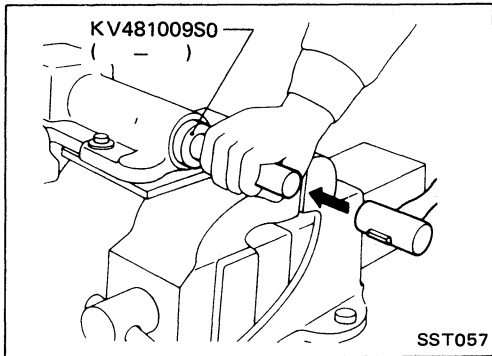

1. Press new oil seal and then install back-up ring with Tool.

2. Install a new snap ring into gear housing.

CAUTION:

- Turn snap ring to make sure it fits into groove.
- Always install snap ring with R face facing inward.

3. Fit new O-ring into sector shaft cover.

- Before installing, apply a thin coat of vaseline to O-ring.
- Make certain that O-ring is installed properly, and not damaged by sector shaft.

SECTOR SHAFT

1. Set piston rack at straight-ahead position.

Turn piston rack about 10° to 15° toward yourself with your finger.

This is for smooth insertion of sector gear.

2. Gradually insert sector shaft into gear housing.

When inserting sector shaft, simultaneously pull out plastic film so that bearings will not drop into housing.

POWER STEERING GEAR (Model : PB56S)

Assembly (Cont'd)

3. Tighten sector shaft cover bolts.

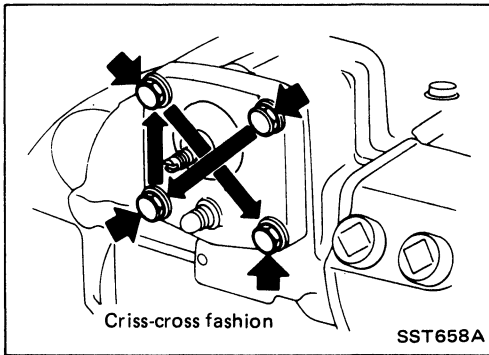

4. Check turning torque and steering gear preload.

Refer to Inspection and Adjustment.

- If there is more than 0.2 N·m (2 kg-cm, 1.7 in-lb) difference between values of turning torque before and after disassembly, it must be assumed that some new problem has occurred. It will be necessary to replace the entire assembly.

POWER STEERING SYSTEM (Model : PB48S)

Description

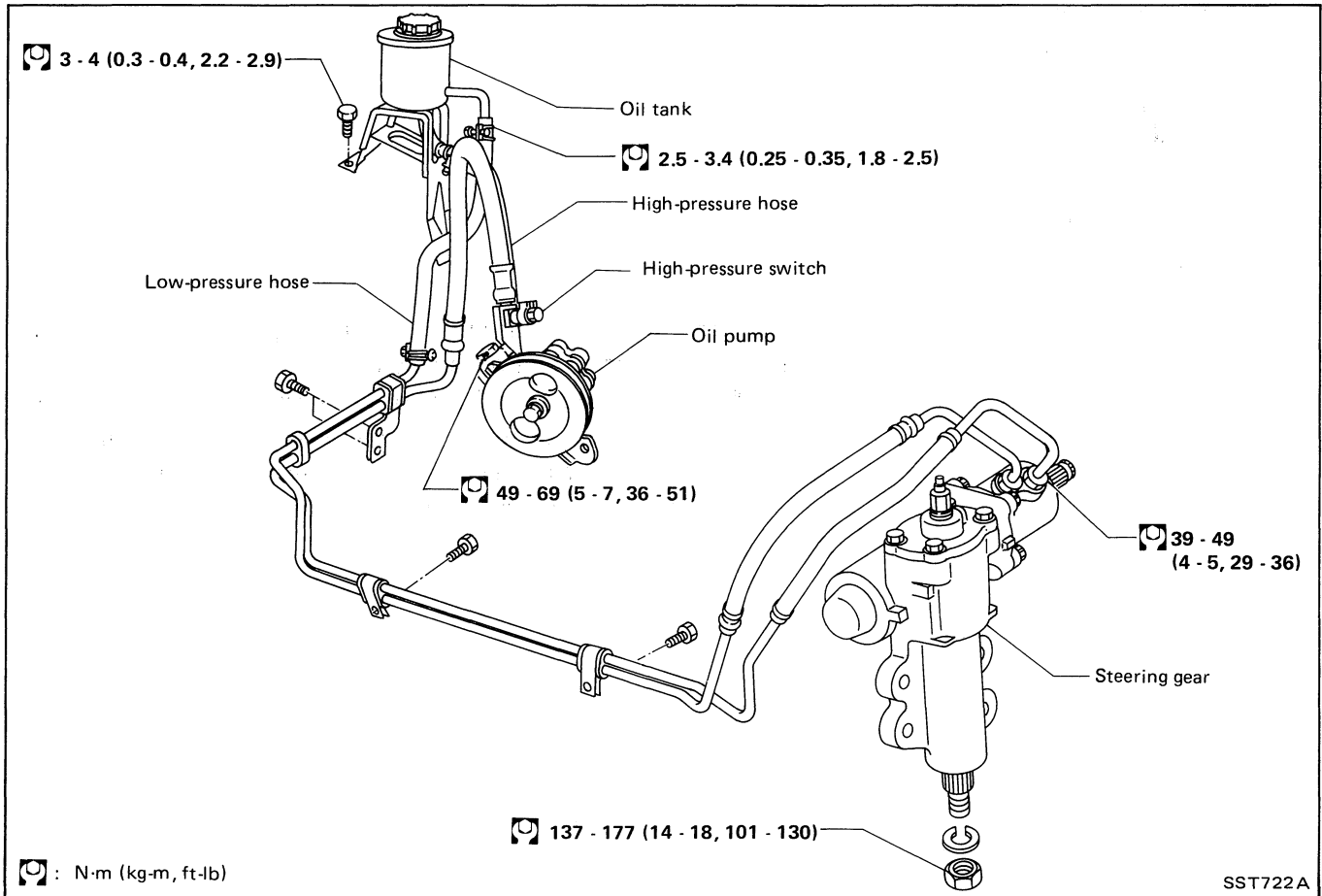

This power steering adopts spool valve control which was developed in a technical tie-up with the ZF Company.

Only the sealing parts can be replaced. The remaining parts must be replaced as an assembly.

CAUTION:

- The parts which can be disassembled are strongly restricted, and never disassemble other parts than the specified ones.
- Disassembly should be performed in a place as clean as possible.
- Hands should be cleaned before disassembly.
- Do not use a rag. Be sure to use nylon or paper cloth.
- Be sure to follow procedures and cautions indicated in the Service Manual.

POWER STEERING GEAR (Model : PB48S)

Removal

Before removing, clean exteriors of gear housing and oil pump with steam and dry with compressed air.

STEERING GEAR

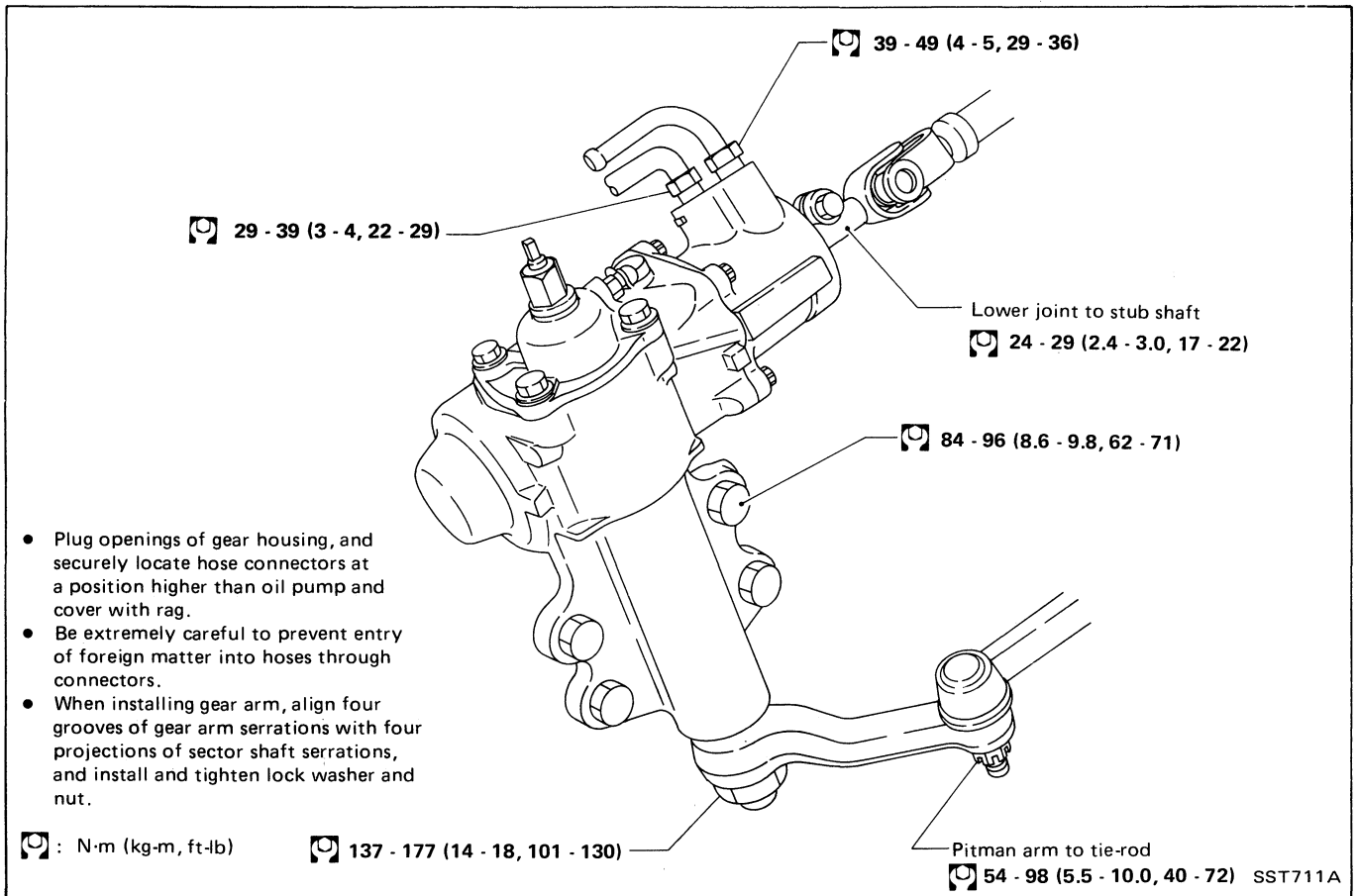

POWER STEERING GEAR (Model : PB48S)

Power Steering Gear Component

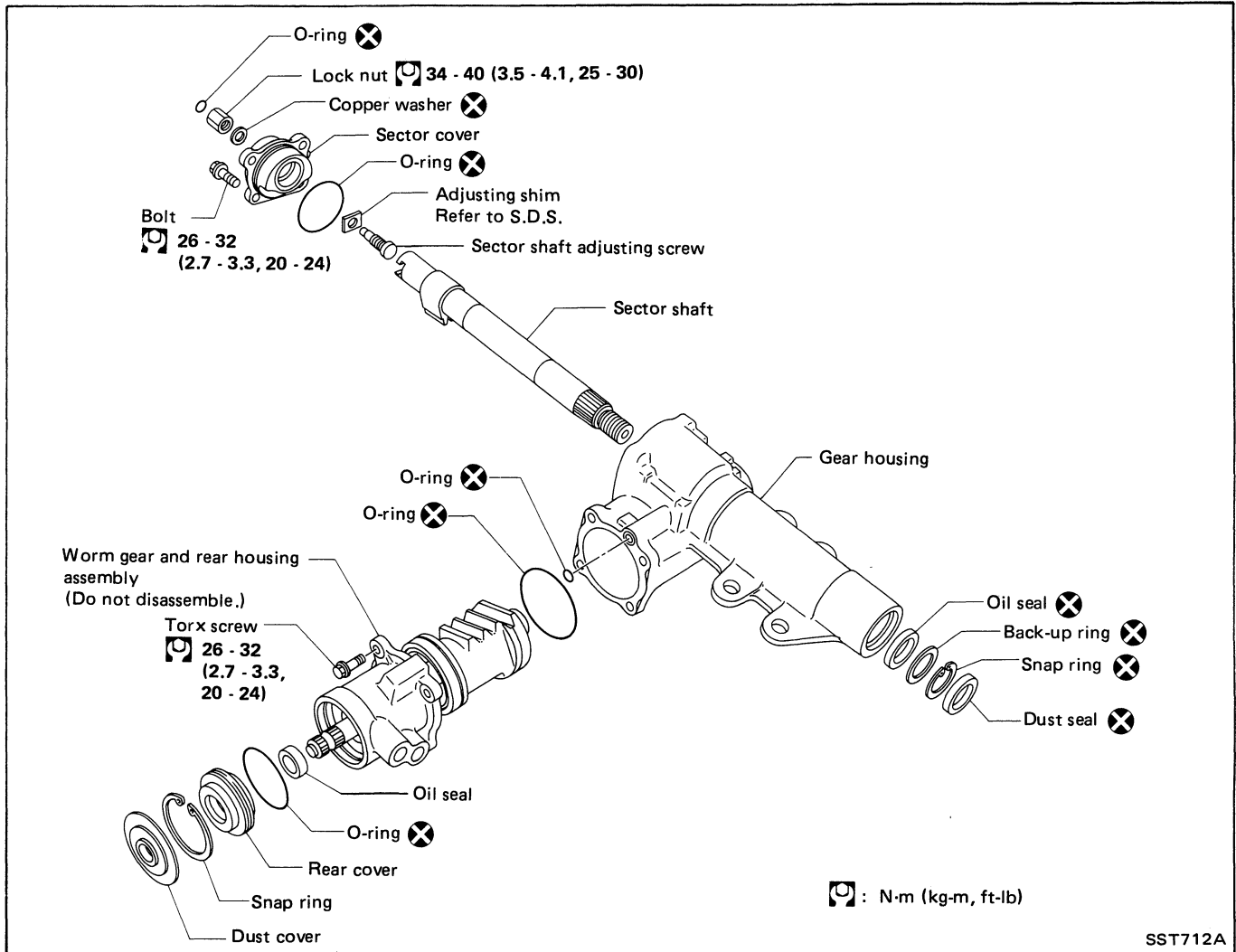

Inspection and Adjustment

Before disassembling power steering gear component parts, make sure there is no oil leakage around sealing portion and check steering turning torque as follows:

Check sealing portion.

- Adjusting screw nut O-ring
- Sector shaft cover O-ring
- Sector shaft oil seal
- Rear cover oil seal and O-ring
- Rear housing O-ring
- Gear housing O-ring

Discard any oil seal and O-ring which have once been removed. Replace oil seal and O-ring if sealing surface is deformed or cracked.

Servicing procedures for PB48S model are almost the same as those for PB56S model. Except for Disassembly and Assembly sections, refer to POWER STEERING GEAR (Model: PB56S).

POWER STEERING GEAR (Model : PB48S)

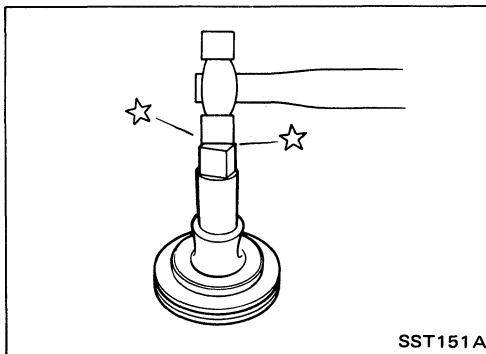
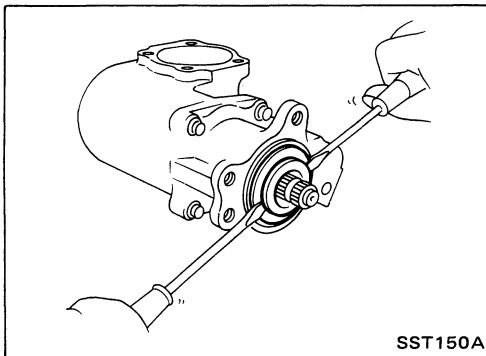
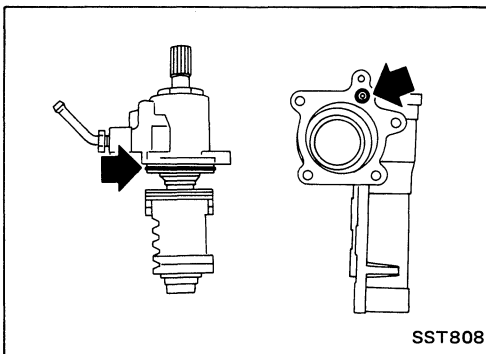
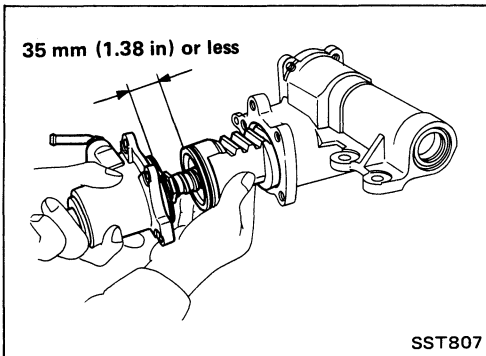
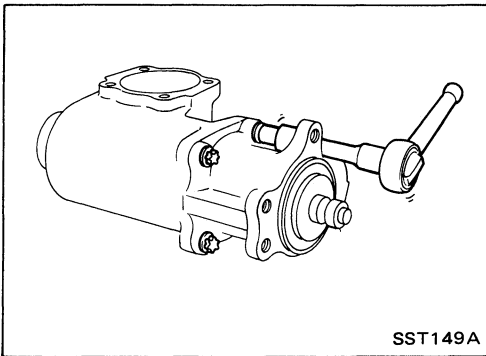

Disassembly

REAR HOUSING O-RING

1. Remove sector shaft. Refer to steps 1 through 5 in "Disassembly of Sector Shaft Oil Seal in POWER STEERING GEAR (Model: PB56S)".
2. Remove torx screws.

3. Remove rear housing together with worm gear assembly.

CAUTION:

- a. When worm assembly is removed, piston may turn and come off under its own weight. Hold piston to prevent it from turning.
If piston-to-rear housing clearance exceeds 35 mm (1.38 in) by loosening recirculating ball will be out of groove of worm; do not reinstall piston but replace the entire assembly.
 - b. Take care not to damage teflon ring at piston end when removing.
4. Remove O-rings.

REAR COVER O-RING AND OIL SEAL

1. Remove snap ring, then rear cover.
2. Remove O-ring and oil seal.

POWER STEERING GEAR (Model : PB48S)

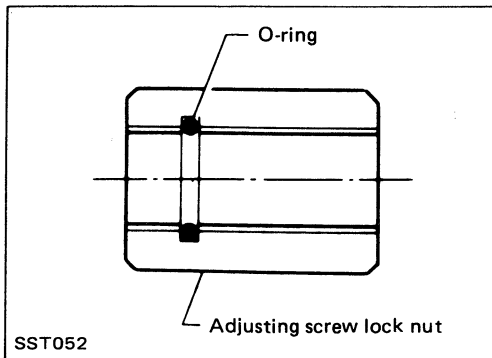

Assembly

ADJUSTING SCREW LOCK NUT O-RING

Insert new O-ring into adjusting screw lock nut.

- Before inserting, apply a thin coat of vaseline to O-ring.
- Insert O-ring to make sure it fits into groove.

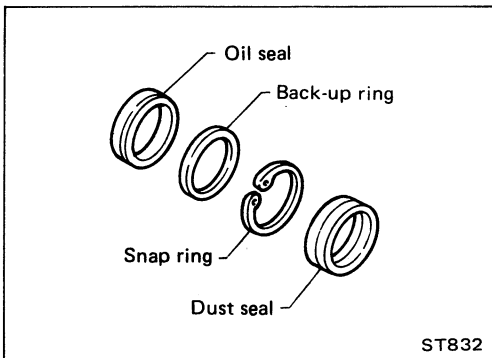

SECTOR SHAFT OIL SEAL

- When installing, be sure to use new oil seal, dust seal, back-up ring and snap ring.
- Before installing, apply a thin coat of vaseline to new oil seal and dust seal.

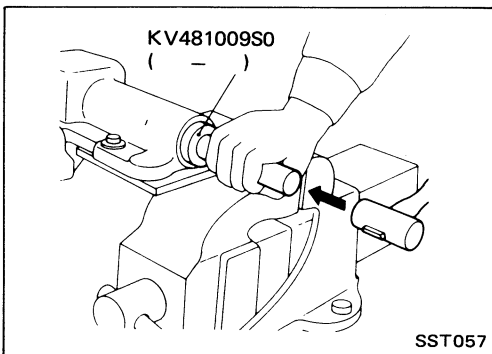

1. Press new oil seal and then install back-up ring with Tool.

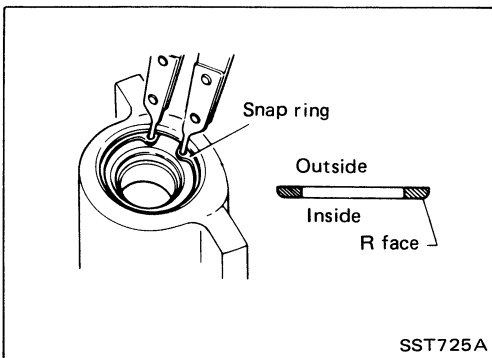

2. Install a new snap ring into gear housing.

CAUTION:

- a. Turn snap ring to make sure it fits into groove.
- b. Always install snap ring with R face facing inward.

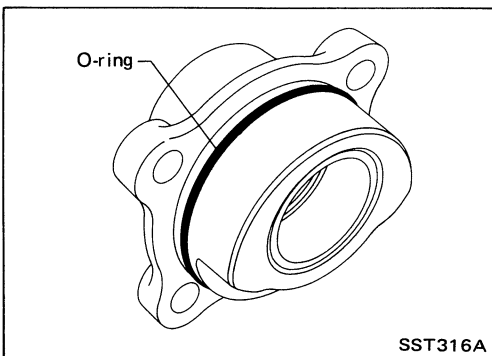

3. Press a new dust seal.

4. Fit new O-ring into sector shaft cover.

- Before installing, apply a thin coat of vaseline to O-ring.
- Make certain that O-ring is installed properly, and not damaged by sector shaft.

POWER STEERING GEAR (Model : PB48S)

Assembly (Cont'd)

SECTOR SHAFT END PLAY

Select suitable adjusting shim and adjust end play between sector shaft and adjusting screw.

Sector shaft end play:

0.01 - 0.03 mm (0.0004 - 0.0012 in)

Sector shaft adjusting screw shims:

Refer to S.D.S.

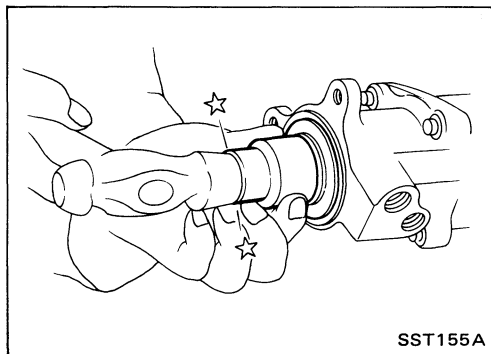
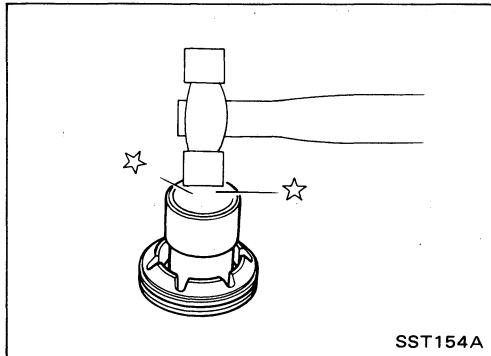
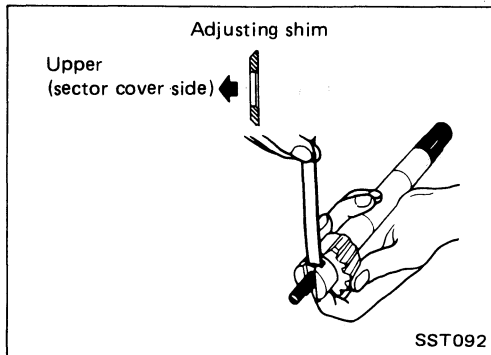

REAR COVER O-RING AND OIL SEAL

1. Install new O-ring and oil seal.

2. Install rear cover, then snap ring.

CAUTION:

- Turn snap ring to make sure it fits into grooves.
- Always install snap ring with its rounded edge facing rear cover.

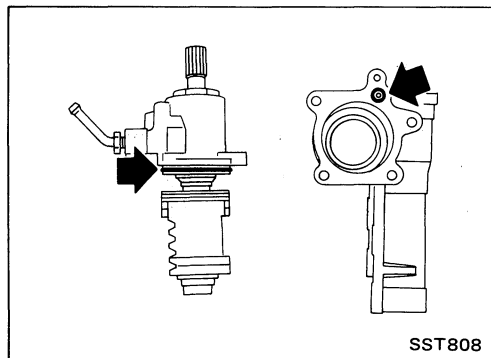

REAR HOUSING O-RING

1. Install new O-rings.

- Before installing, apply a thin coat of vaseline to O-ring.
- Make sure O-ring is installed correctly and is not damaged by worm gear.

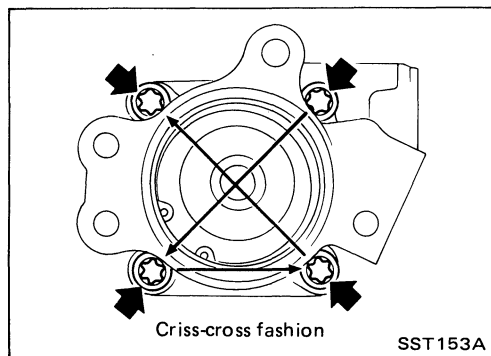

2. Gradually insert worm gear and rear housing assembly into gear housing, being careful not to damage oil seal and O-rings.

3. Install torx screws.

POWER STEERING GEAR (Model : PB48S)

Assembly (Cont'd)

SECTOR SHAFT

1. Set piston rack at straight-ahead position.
Turn piston rack about 10° to 15° toward yourself with your finger.

This is for smooth insertion of sector gear.

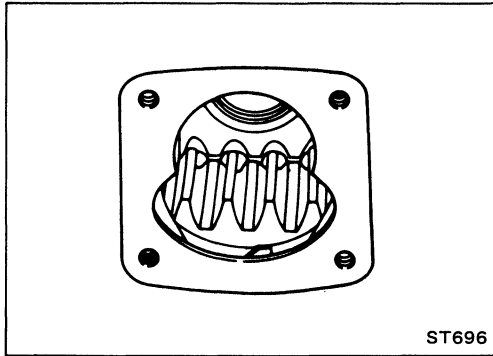

2. Wrap vinyl tape around serration area of sector shaft.
The reason is that vinyl tape prevents oil seal lip from being damaged during insertion.
3. Gradually insert sector shaft into gear housing, being careful not to damage oil seal.

When inserting sector shaft into gear housing, remove plastic film. Be careful not to drop bearings into gear housing.

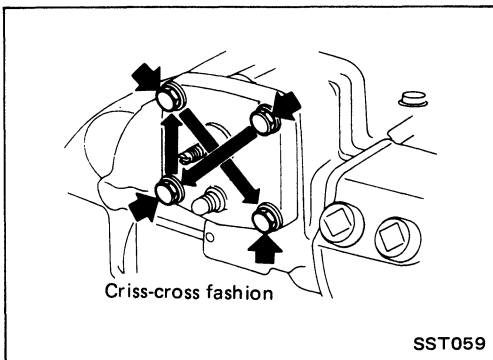

4. Tighten sector shaft cover bolts.

5. Check turning torque and steering gear preload.

Refer to Inspection and Adjustment of POWER STEERING GEAR (Model: PB56S)

- If there is a great difference between values of turning torque before and after disassembly, it must be assumed that some new problem has occurred. It will be necessary to replace the entire assembly.

POWER STEERING OIL PUMP

Models equipped with Z engine

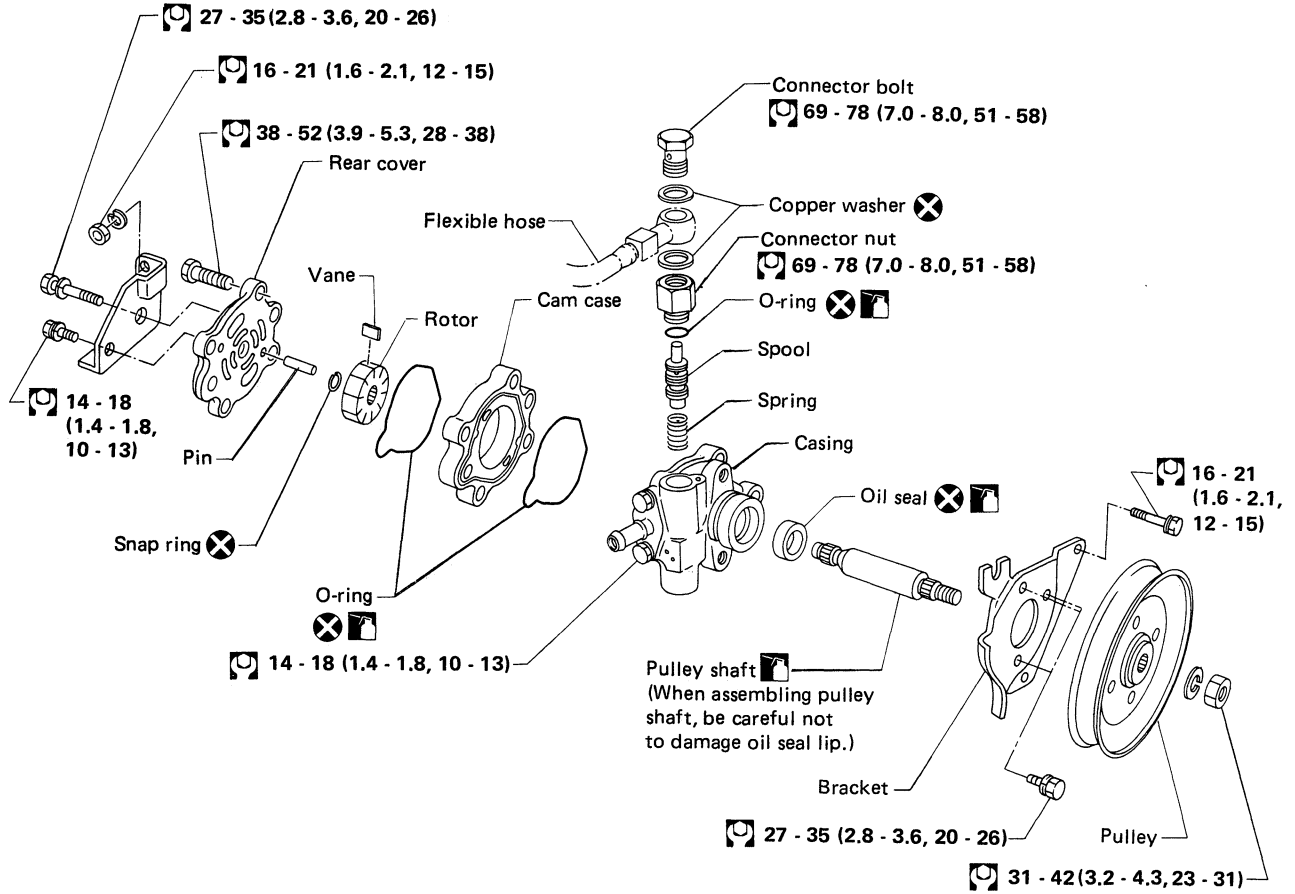

Models equipped with VG engine

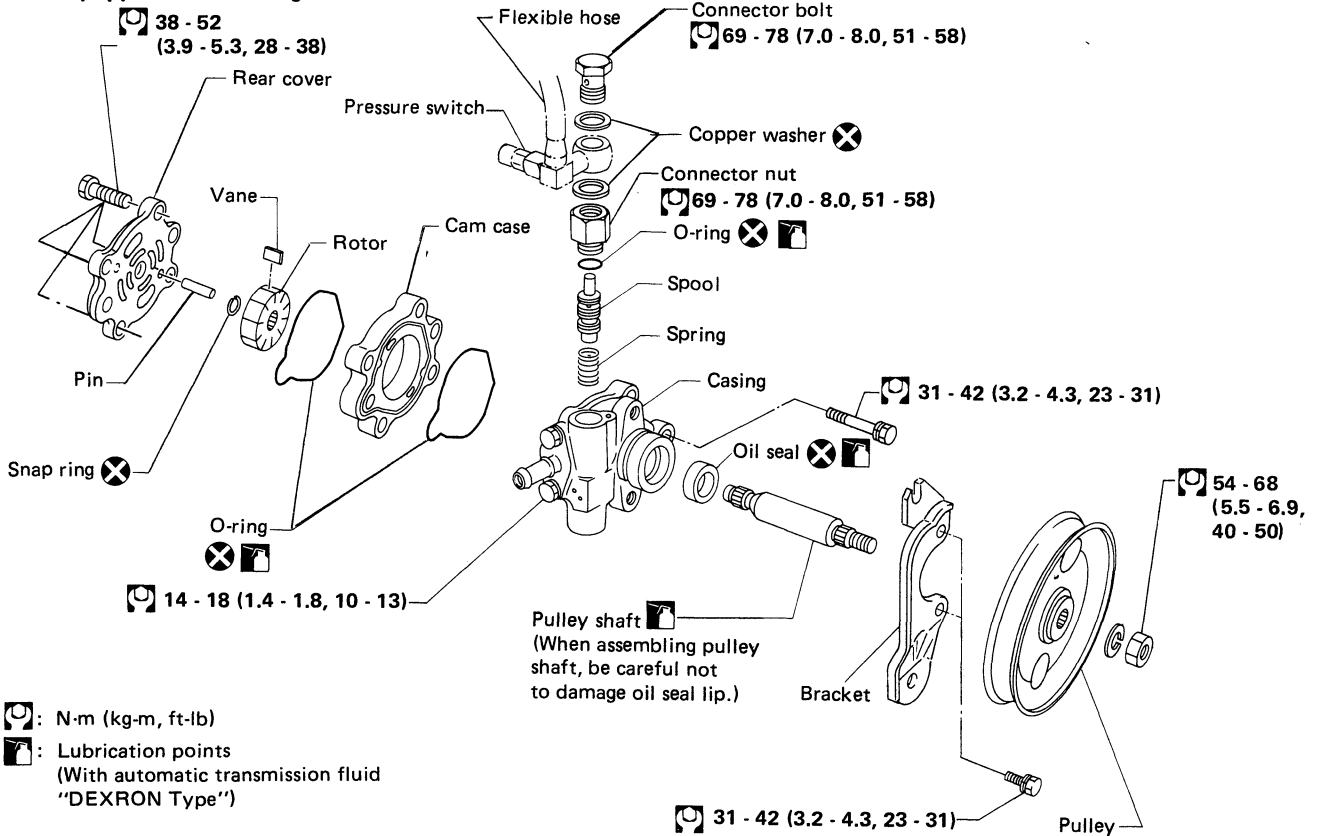

- : N·m (kg·m, ft·lb)
- : Lubrication points
(With automatic transmission fluid "DEXRON Type")

SST895A

POWER STEERING OIL PUMP

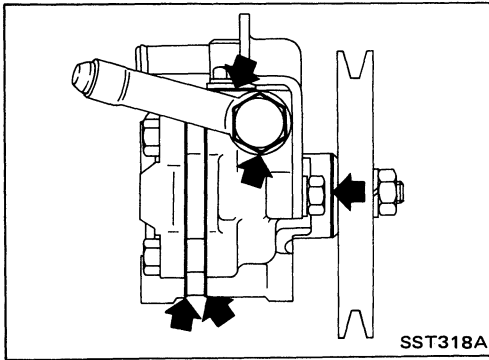

The power steering oil pump should be disassembled only if any of the following conditions are observed.

- Oil leak
- Deformed or damaged pulley

Disassembly

CAUTION:

- The parts which can be disassembled are strictly limited, and never disassemble other parts than the specified ones.
- Disassembly should be performed in a place as clean as possible.
- Hands should be cleaned before disassembly.
- Do not use a rag. Be sure to use nylon or paper cloth.
- Be sure to follow procedures and cautions indicated in the Service Manual.
- When disassembling and reassembling, do not allow any foreign matter to enter or contact any parts.

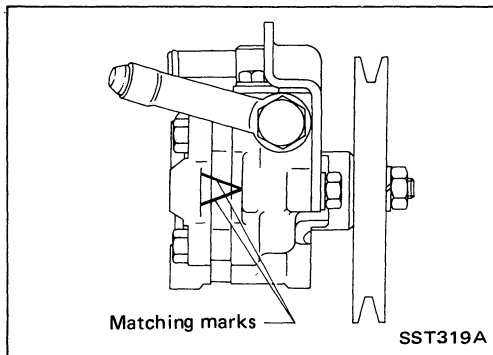

1. Inscribe matching marks.

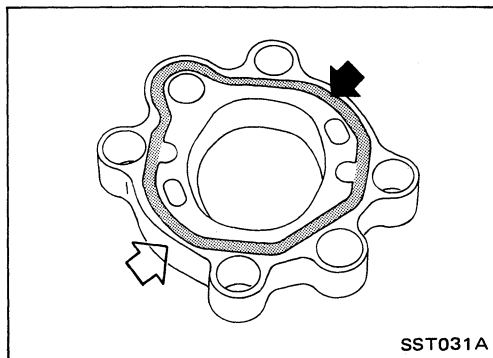

2. Remove rear cover.
3. Remove O-ring from cam case.

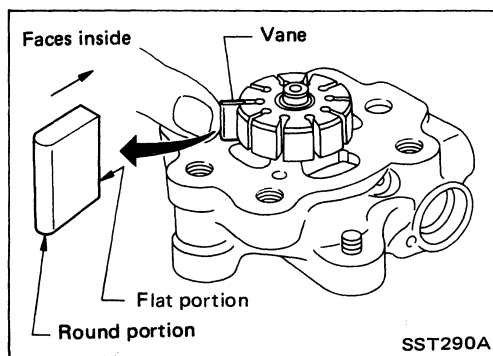

CAUTION:

- When removing cam case, be sure that the vane does not come off the rotor.

POWER STEERING OIL PUMP

Disassembly (Cont'd)

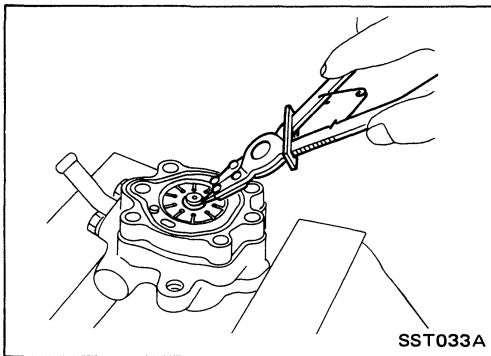

4. Remove snap ring, then draw pulley shaft out.
 - Be careful not to drop pulley shaft.

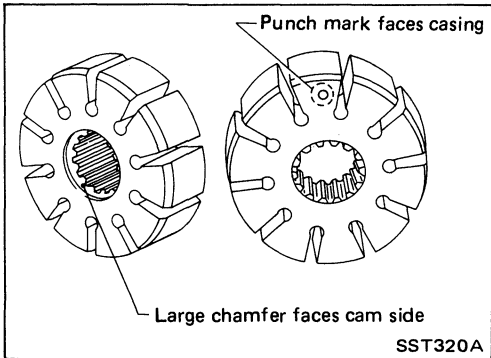

5. Pay attention to the direction of rotor.

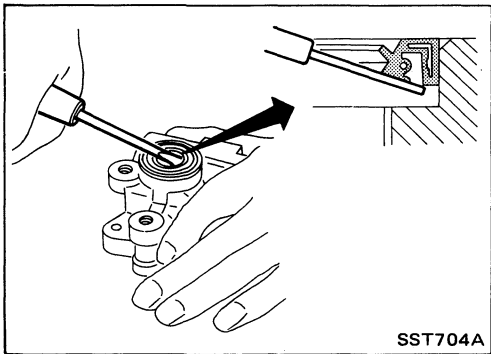

6. Remove oil seal.
 - Be careful not to damage casing.

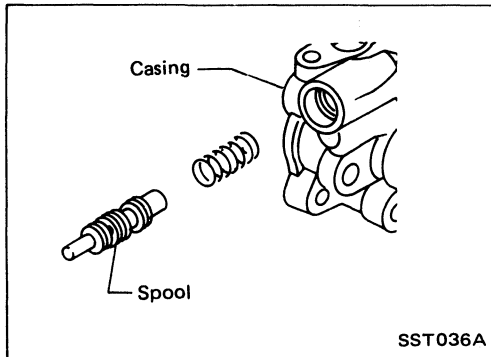

7. Remove connector.
 - Be careful not to drop spool.

8. Remove suction pipe, then remove O-ring.

POWER STEERING OIL PUMP

Inspection

Wash clean all disassembled parts in suitable cleaning solvent.

PULLEY AND PULLEY SHAFT

- a. If pulley is cracked or deformed, replace it.
- b. If an oil leak is noticed around pulley shaft oil seal, replace it.
- c. If serration of pulley or pulley shaft is deformed or worn, replace it.

CONNECTOR

- a. If connector is deformed or cracked, replace oil pump assembly.
- b. If an oil leak is noticed, replace O-ring.

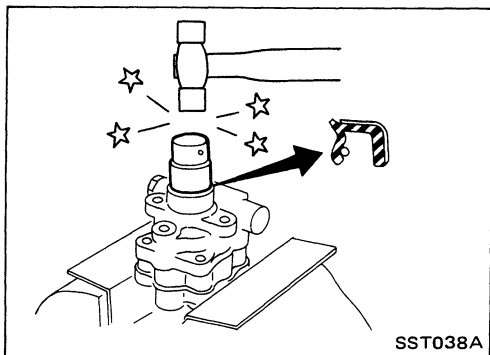

Assembly

Assemble oil pump in the reverse order of disassembly, noting the following instructions.

- Before installing O-rings and oil seal, apply a thin coat of power steering fluid to them.
 - Make certain that O-rings and oil seal are installed properly.
 - Always install new O-rings and oil seal.
 - Be careful of oil seal direction.
-
- Install rotor so that larger chamfer of spline faces the cam side and smaller chamfer faces the front housing. (Or install rotor so that portion with punch mark faces the front housing and portion without punch mark faces the cam side.)

STEERING LINKAGE

Removal and Installation

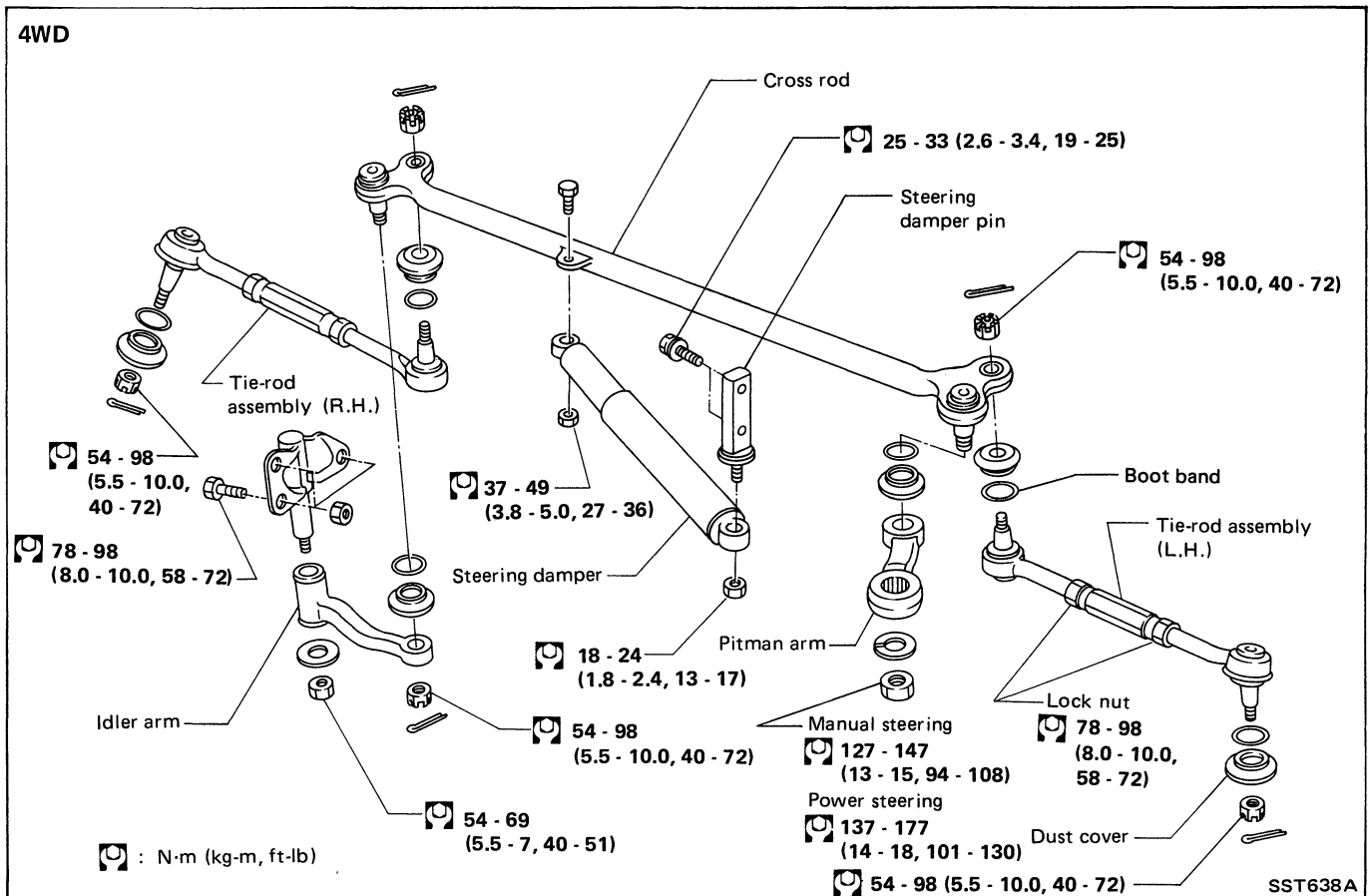
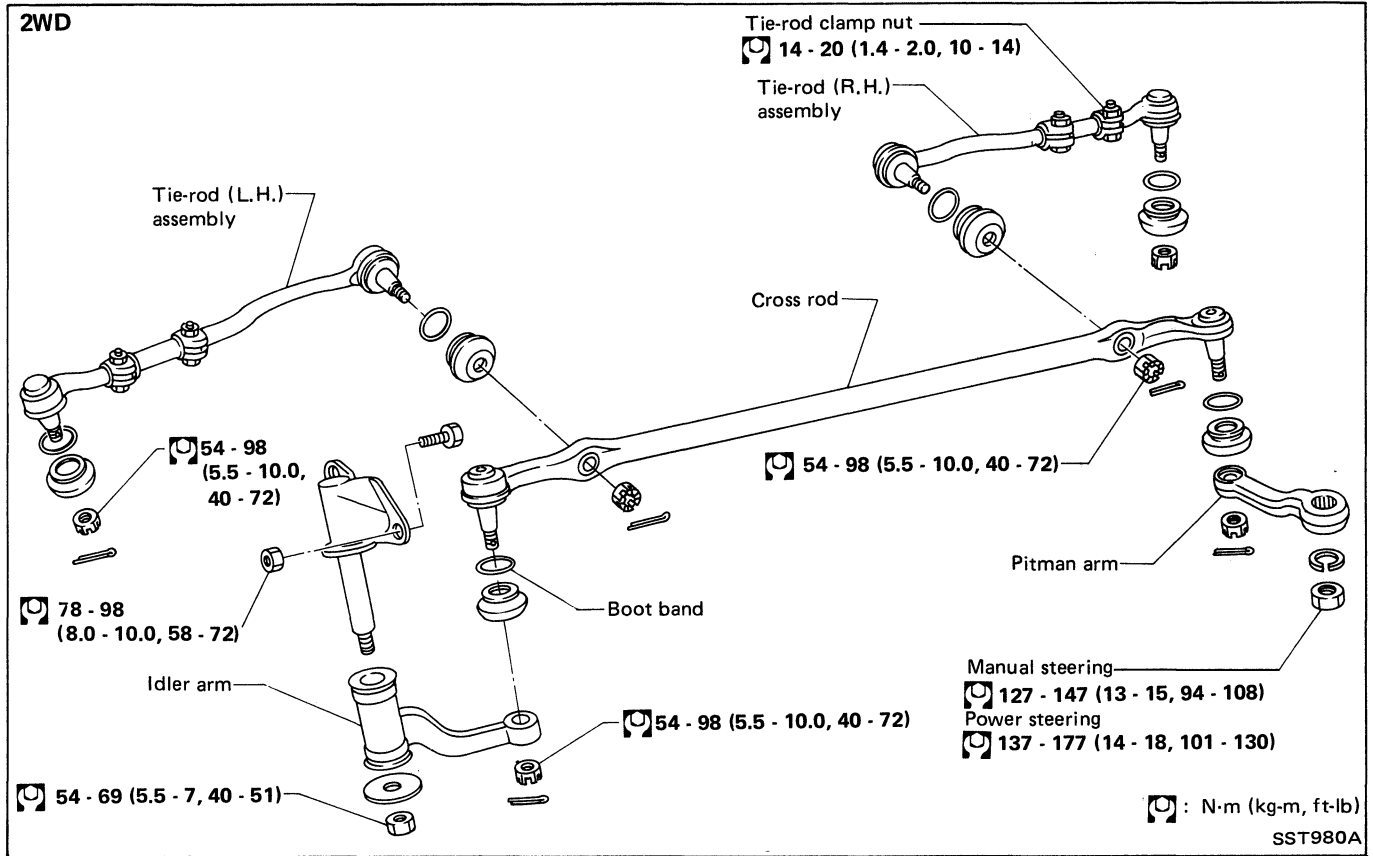

STEERING LINKAGE

Removal and Installation (Cont'd)

Remove gear arm with Tool.

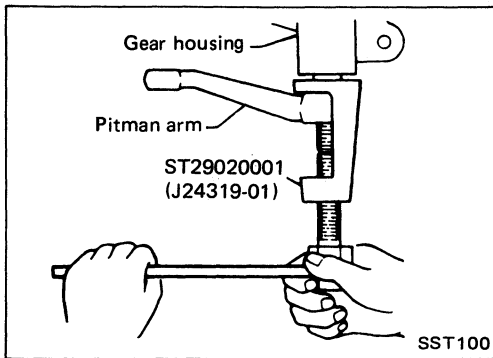

Remove tie-rod from knuckle arm with Tool.

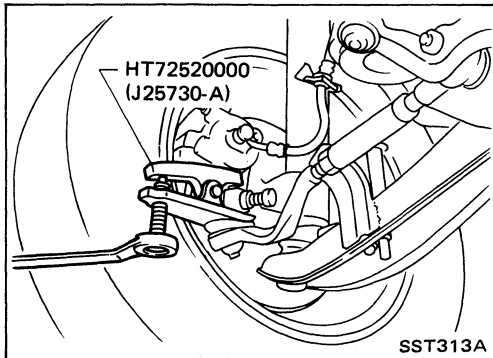

Disassembly

IDLER ARM ASSEMBLY

- Apply coat of multi-purpose grease to bushing.
- Press bushing into idler body, and insert shaft of idler bracket carefully until bushing protrudes.

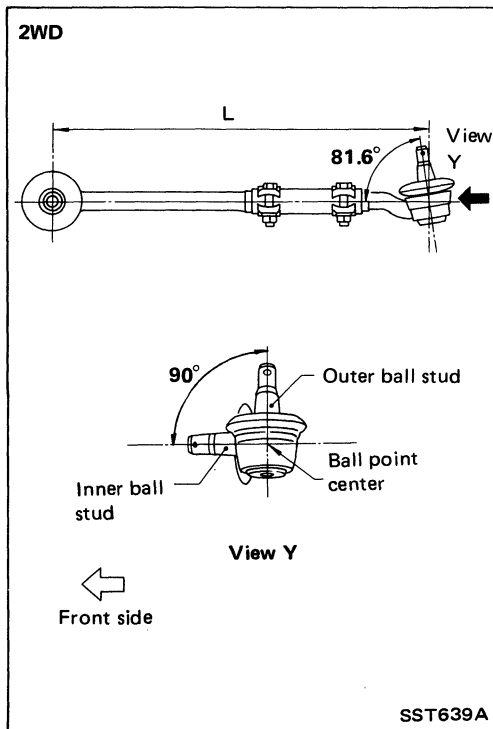

CROSS ROD AND TIE-ROD

1. When tie-rod ball joints and tie-rod bar are separated, adjust tie-rod length correctly.

Adjustment should be done between ball stud centers.

L: Standard

344 mm (13.54 in) ... 2WD

2. Lock tie-rod clamp nut so that ball joint on outer ball stud is as follows with respect to that on inner ball stud.

CAUTION:

Make sure that tie-rod bars are screwed into tie-rod tube more than 35 mm (1.38 in).

STEERING LINKAGE

Disassembly (Cont'd)

L: Standard

281 mm (11.06 in) ... 4WD

CAUTION:

Make sure that tie-rod bars are screwed into tie-rod tube more than 35 mm (1.38 in).

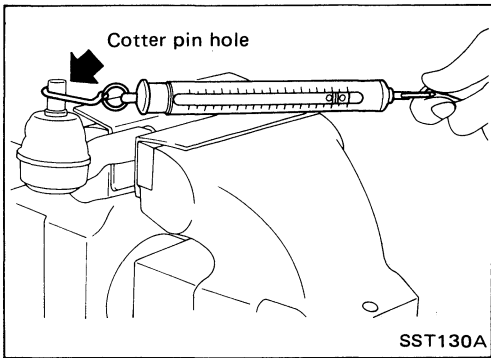
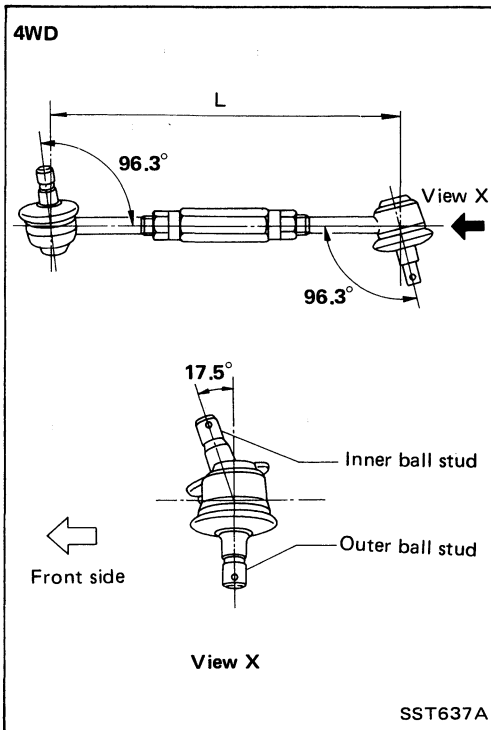

Inspection

BALL JOINT

1. Check ball joint for play. If ball stud is worn and play in axial direction is excessive or joint is hard to swing, replace as a complete unit.

Swinging force*:

Ball joint

10.8 - 108.9 N

(1.1 - 11.1 kg, 2.4 - 24.5 lb)

*Measure point: Cotter pin hole

2. Check condition of dust cover. If it is cracked excessively, replace dust cover.
- When replacing dust cover, be careful not to damage it.
 - Lubricate ball joint with multi-purpose grease, if necessary.

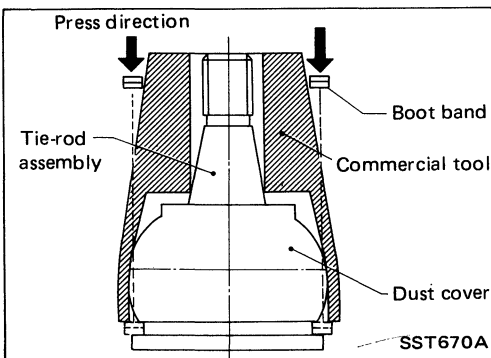

- When installing boot band with *commercial tool, be careful not to overexpand it.

* Refer to PREPARATION.

CAUTION:

Be careful not to apply grease or oil to taper of ball joint.

STEERING LINKAGE

Inspection (Cont'd)

IDLER ARM ASSEMBLY

- Check rubber bushing of idler arm for breakage, wear or play, and if necessary replace.
- Lubricate idler arm assembly with recommended multi-purpose grease, if necessary.

When lubricating, refer to BALL JOINT of Inspection.

CROSS ROD AND TIE-ROD

Check tie-rod and cross rod for breakage, bend or crack, and replace with a new one if necessary.

STEERING DAMPER

Check for oil leakage and measure damping force of damper, and replace if necessary.

Damping force:

at 0.3 m (1.0 ft)/sec

1,942 N (198 kg, 437 lb)

. . . Extended direction

1,775 N (181 kg, 399 lb)

. . . Compressed direction

FIXING LOCATION

- Check fixing location (nuts and cotter pins) for looseness, play or breakage.
- When looseness or play is found, check for wear on tapered portion of ball stud, gear arm of idler arm.
- When reassembling each ball joint, use new cotter pins.

SERVICE DATA AND SPECIFICATIONS (S.D.S.)

General Specifications

Steering column type (Collapsible)	Manual steering	Power steering	
Steering gear type	B56S	PB48S	PB56S
Turns of steering wheel on the vehicle (Lock-to-lock)	4.9 (2WD) 5.0 (4WD) 3.9*1	3.7	3.8 3.0*1
Steering gear ratio	22	16.5	17.0
Steering damper (4WD) [at 0.3 m (1.0 ft)/sec.] N (kg, lb)	1,942 (198, 437)*2 1,775 (181, 399)*3		

Steering wheel axial play mm (in)	0 (0)
Steering wheel play mm (in)	35 (1.38) or less

*1: 4WD: Tire size ... 10.50R15

*2: Extended direction

*3: Compressed direction

Inspection and Adjustment

STEERING COLUMN

Unit: mm (in)

	Dimension "L"
2WD model	918.0 - 919.6 (36.14 - 36.20)
4WD model	886.1 - 887.7 (34.89 - 34.95)

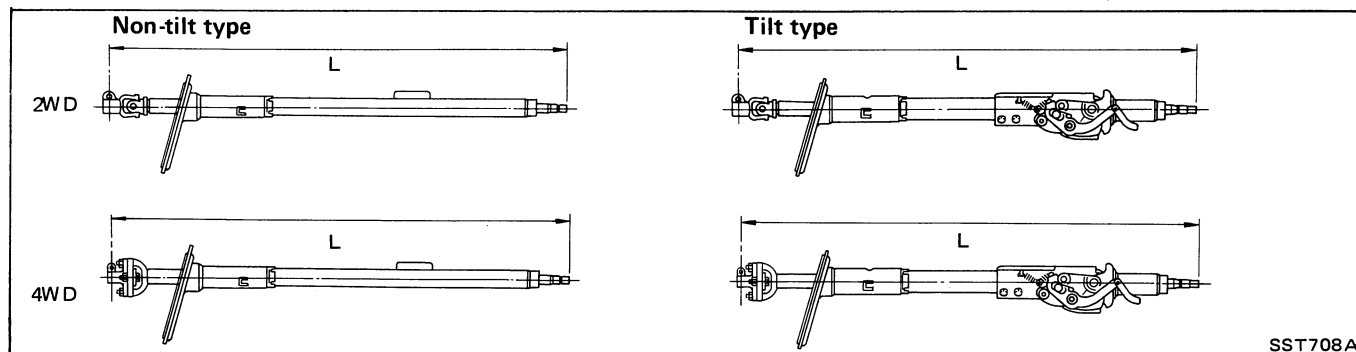

SST708A

SERVICE DATA AND SPECIFICATIONS (S.D.S.)

Inspection and Adjustment (Cont'd)

MANUAL STEERING GEAR (Model: B56S)

Worm bearing preload (Without oil seal) N·m (kg-cm, in-lb)	0.20 - 0.59 (2.0 - 6.0, 1.7 - 5.2)	
Steering gear preload (With oil seal) N·m (kg-cm, in-lb)		
New parts	0.83 - 1.23 (8.5 - 12.5, 7.4 - 10.9)	
Used parts	0.59 - 0.98 (6.0 - 10.0, 5.2 - 8.7)	
Backlash at pitman arm top end (in a straight- ahead position) mm (in)		
New gear	0 - 0.1 (0 - 0.004)	
Used gear	0 - 0.3 (0 - 0.012)	
End play (Between sector shaft and adjusting screw) mm (in)	0.01 - 0.03 (0.0004 - 0.0012)	
Adjusting shim thickness	Thickness mm (in)	Part number
	1.575 - 1.600 (0.0620 - 0.0630)	48213-B0100
	1.550 - 1.575 (0.0610 - 0.0620)	48214-B0100
	1.525 - 1.550 (0.0600 - 0.0610)	48215-B0100
	1.500 - 1.525 (0.0591 - 0.0600)	48216-B0100
	1.475 - 1.500 (0.0581 - 0.0591)	48217-B0100
	1.450 - 1.475 (0.0571 - 0.0581)	48218-B0100
Oil capacity liters (US pt, Imp pt)	Approx. 0.33 (3/4, 5/8)	

POWER STEERING SYSTEM (Model: PB48S, PB56S)

Steering wheel turning force (at 360° from neutral position and circumference of steering wheel) N (kg, lb)	24.5 - 29.4 (2.5 - 3.0, 5.5 - 6.6) 39 (4, 9) or less*	
Oil pump pressure kPa (kg/cm ² , psi)	7,649 - 8,238 (78 - 84, 1,109 - 1,194) at idling	
Fluid capacity ml (US fl oz, Imp fl oz)	Approximately 900 - 1,000 (30.4 - 33.8, 31.7 - 35.2)	
Normal operating temperature °C (°F)	60 - 80 (140 - 176)	
Steering gear turning torque N·m (kg-cm, in-lb) 360° position from straight-ahead position	0.7 - 1.2 (7 - 12, 6.1 - 10.4)	
Straight-ahead position (As compared with steering wheel turned 360°)	0.1 - 0.4 (1 - 4, 0.9 - 3.5) higher	
Backlash at pitman arm top end (in a straight- ahead position) mm (in)	0 - 0.1 (0 - 0.004)	
End play (Between sector shaft and adjusting screw) mm (in)	0.01 - 0.03 (0.0004 - 0.0012)	
Adjusting shim thickness	Thickness mm (in)	Part number
	1.575 - 1.600 (0.0620 - 0.0630)	48213-B0100
	1.550 - 1.575 (0.0610 - 0.0620)	48214-B0100
	1.525 - 1.550 (0.0600 - 0.0610)	48215-B0100
	1.500 - 1.525 (0.0591 - 0.0600)	48216-B0100
	1.475 - 1.500 (0.0581 - 0.0591)	48217-B0100
	1.450 - 1.475 (0.0571 - 0.0581)	48218-B0100

*Model: PB56S-type

STEERING LINKAGE

Model	2WD	4WD
Ball joint swinging force* N (kg, lb)		
New part	10.8 - 108.9 (1.1 - 11.1, 2.4 - 24.5)	
Used part	10.8 (1.1, 2.4) or more	
Standard tie-rod length mm (in)	Approx. 344 (13.54)	Approx. 281 (11.06)

*Measuring point: Cotter pin hole

SERVICE DATA AND SPECIFICATIONS (S.D.S.)

Tightening Torque

STEERING COLUMN

Unit	N·m	kg·m	ft·lb
Steering wheel nut	29 - 39	3.0 - 4.0	22 - 29
Steering column mounting bracket	13 - 18	1.3 - 1.8	9 - 13
Jacket tube bracket to dash panel	9 - 14	0.9 - 1.4	6.5 - 10.1
Tilt joint fixing bolt	24 - 29	2.4 - 3.0	17 - 22
Mounting bracket to lower jacket tube (Tilt type)	16 - 21	1.6 - 2.1	12 - 15
Steering column shaft to coupling	24 - 29	2.4 - 3.0	17 - 22
Coupling to column shaft and gear	24 - 29	2.4 - 3.0	17 - 22
Coupling fixing nut	16 - 22	1.6 - 2.2	12 - 16

MANUAL STEERING GEAR

Unit	N·m	kg·m	ft·lb
Steering gear housing to body side frame	84 - 96	8.6 - 9.8	62 - 71
Pitman arm to sector shaft	127 - 147	13 - 15	94 - 108
Sector shaft cover bolt	15 - 25	1.5 - 2.5	11 - 18
Sector shaft adjusting screw lock nut	29 - 39	3.0 - 4.0	22 - 29
Adjusting plug lock nut	245 - 314	25 - 32	181 - 231

POWER STEERING SYSTEM

Installation

Unit	N·m	kg·m	ft·lb
Steering gear housing to body side frame	84 - 96	8.6 - 9.8	62 - 71
Pitman arm to sector shaft	137 - 177	14 - 18	101 - 130
Oil pump to engine bracket			
Z engine model	16 - 21	1.6 - 2.1	12 - 15
VG engine model	31 - 42	3.2 - 4.3	23 - 31
Tank fixing bolt bracket	3 - 4	0.3 - 0.4	2.2 - 2.9
High-pressure pipe to gear	29 - 39	3.0 - 4.0	22 - 29
Low-pressure pipe to gear	39 - 49	4.0 - 5.0	29 - 36
Low-pressure hose clip bolt	2.5 - 3.4	0.25 - 0.35	1.8 - 2.5
High-pressure hose to oil pump	49 - 69	5.0 - 7.0	36 - 51

Power steering gear

Unit	N·m	kg·m	ft·lb
Sector shaft cover bolt	26 - 32	2.7 - 3.3	20 - 24
Sector shaft adjusting screw lock nut	34 - 40	3.5 - 4.1	25 - 30
Rear housing bolt	26 - 32	2.7 - 3.3	20 - 24
Bleeder screw*	6 - 8	0.6 - 0.8	4.3 - 5.8

*: Only 2WD model

Power steering oil pump

Unit	N·m	kg·m	ft·lb
Pulley lock nut			
(Z engine)	31 - 42	3.2 - 4.3	23 - 31
(VG engine)	54 - 68	5.5 - 6.9	40 - 50
Rear cover fixing bolt	38 - 52	3.9 - 5.3	28 - 38
Connector bolt	69 - 78	7.0 - 8.0	51 - 58
Connector nut	69 - 78	7.0 - 8.0	51 - 58
Suction pipe	14 - 18	1.4 - 1.8	10 - 13
Oil pump bracket			
(Z engine)	27 - 35	2.8 - 3.6	20 - 26
(VG engine)	31 - 42	3.2 - 4.3	23 - 31

STEERING LINKAGE

Unit	N·m	kg·m	ft·lb
Idle arm to body side frame	78 - 98	8.0 - 10.0	58 - 72
Idle arm nut	54 - 69	5.5 - 7.0	40 - 51
Ball stud nut	54 - 98	5.5 - 10.0	40 - 72
Tie-rod clamp nut (2WD)	14 - 20	1.4 - 2.0	10 - 14
Tie-rod lock nut (4WD)	78 - 98	8.0 - 10.0	58 - 72
Steering damper			
To cross rod	37 - 49	3.8 - 5.0	27 - 36
To damper pin	18 - 24	1.8 - 2.4	13 - 17
Pin to body	25 - 33	2.6 - 3.4	19 - 25

SECTION BF**CONTENTS**

GENERAL SERVICING (Including all clips and fasteners for using this model)	BF- 2
BODY END	BF- 6
DOOR (Including "Power Window" & "Power Door Lock")	BF-12
INTERIOR AND EXTERIOR (In EXTERIOR, including "Weatherstrips")	BF-18
INSTRUMENT (Including "Center Console")	BF-32
SEAT	BF-33
WINDSHIELD AND WINDOWS	BF-36
SUN ROOF	BF-44
MIRROR (Including wiring diagram)	BF-45
CAB AND REAR BODY	BF-46
BODY ALIGNMENT	BF-51

When you read wiring diagrams:

- Read GI section, "HOW TO READ WIRING DIAGRAMS".
- See EL section, "POWER SUPPLY ROUTING" for power distribution circuit.

★ For seat belt, refer to MA section.



GENERAL SERVICING

Precautions

- When removing or installing various parts, place a cloth or padding onto the vehicle body to prevent scratches.
- Handle trim, molding, instruments, grille, etc. carefully during removing or installation. Be careful not to soil or damage them.
- Apply sealing compound where necessary when installing parts.
- When applying sealing compound, be careful that the sealing compound does not protrude from parts.
- When replacing any metal parts (for example body outer panel, members, etc.), be sure to take rust prevention measures.



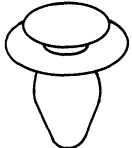

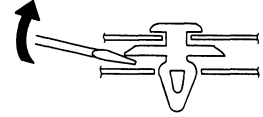
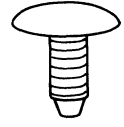
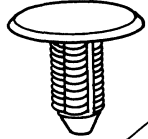
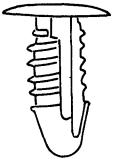
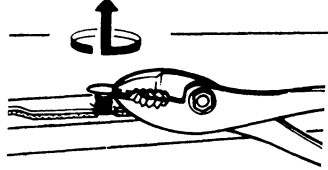
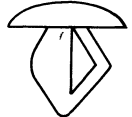
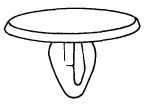
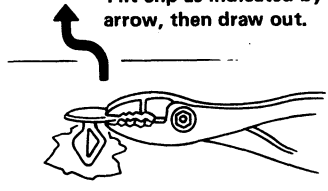
Clip and Fastener

- Clips and fasteners in BF section correspond to the following numbers and symbols.
- Replace any clips and/or fasteners which are damaged during removal or installation.

No.	Symbol	Shape	Removal & Installation
C101	 SBF092B	 SBF109B	Removal: Remove by bending up with a flat-bladed screwdriver.  SBF094B
C102	 SBF113B	 SBF114B  SBF137B	 Removal: Pull up by rotating SBF115B
C105	 SBF141B	 SBF142B	Removal: Tilt clip as indicated by arrow, then draw out.  SBF143B

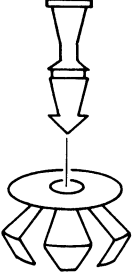
GENERAL SERVICING

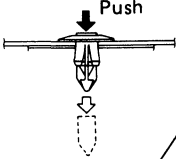
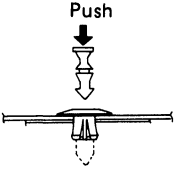
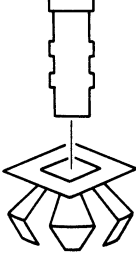
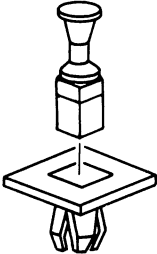
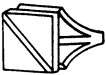
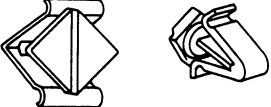
Clip and Fastener (Cont'd)

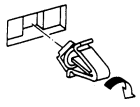
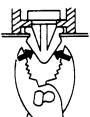
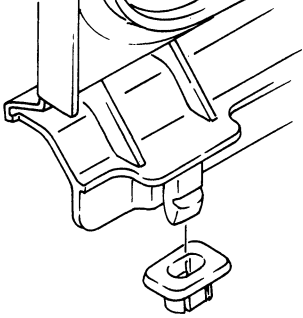
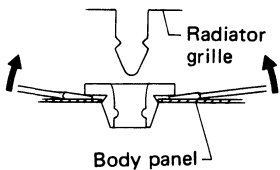
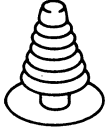
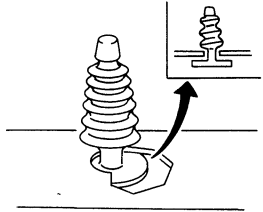
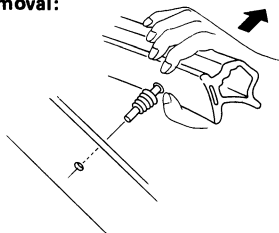
No.	Symbol	Shape	Removal & Installation
C203	 <p>SBF318C</p>	 <p>SBF319C</p>	<p>Push center pin to catching position. (Do not remove center pin by hitting it.)</p>  <p>Push</p>  <p>Push</p> <p>Installation:</p> <p>SBF320C</p>
C204	 <p>SBF321C</p>	 <p>SBF322C</p>	
CG101	 <p>SBF144B</p>	 <p>SBF145B</p>	<p>Removal:</p>  <p>Rotate 45° to remove.</p> <p>Installation:</p>  <p>Removal:</p>  <p>SBF085B</p>
CG104	 <p>SBF351C</p>	<p>Removal:</p> <p>Remove by bending up with flat-bladed screwdrivers.</p>  <p>Radiator grille</p> <p>Body panel</p> <p>SBF352C</p>	
CE103	 <p>SBF103B</p>	 <p>SBF104B</p>	<p>Removal:</p>  <p>SBF147B</p>





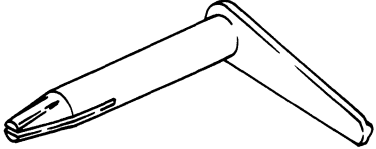
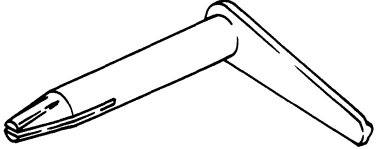
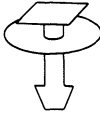
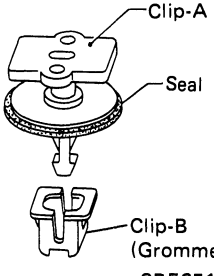
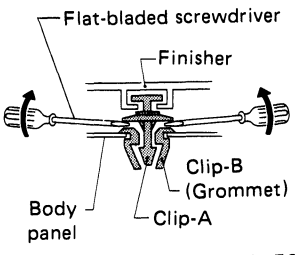
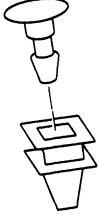
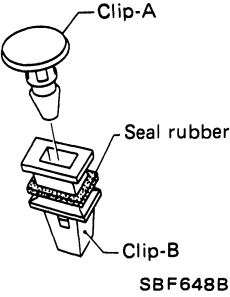
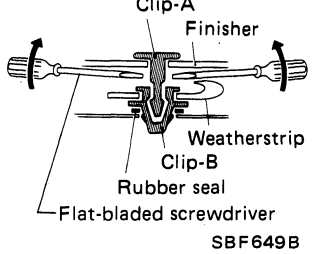
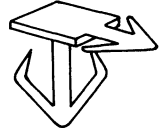
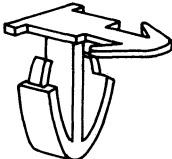
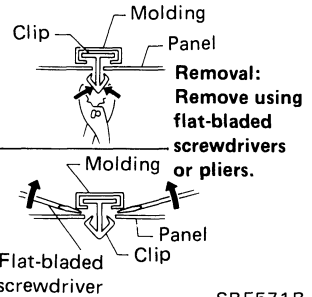
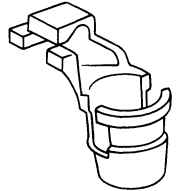
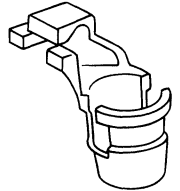
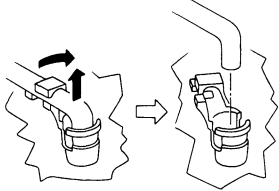

GENERAL SERVICING

Clip and Fastener (Cont'd)

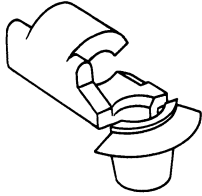
No.	Symbol	Shape	Removal & Installation
CE114		 SBF353C	—
CF109	 SBF650B	 SBF651B	Removal:  SBF652B
CF110	 SBF647B	 SBF648B	Removal:  SBF649B
CF114	 SBF316C	 SBF317C	 SBF571B
CR103		 SBF768B	Removal: Holder portion of clip must be spread out to remove rod.  SBF770B

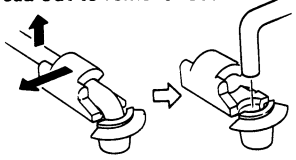
GENERAL SERVICING

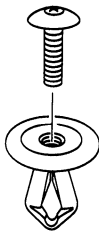
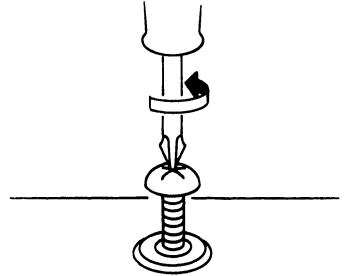
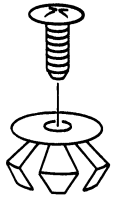
Clip and Fastener (Cont'd)

No.	Symbol	Shape	Removal & Installation
CR104			<p>Removal: Holder portion of clip must be spread out to remove rod.</p>  <p style="text-align: right;">SBF861B</p>
CS102	 <p style="text-align: center;">SBF138B</p>	 <p style="text-align: center;">SBF139B</p>	<p>Removal: Screw out with a Phillips screwdriver.</p>  <p style="text-align: right;">SBF140B</p>
CS103	 <p style="text-align: center;">SBF363B</p>	 <p style="text-align: center;">SBF364B</p>	

BODY END

Front End

- Hood adjustment: Adjust at hinge portion.
- Hood lock adjustment: After adjusting, check hood lock control operation. Apply a coat of grease to hood locks engaging mechanism.
- Hood opener: Do not attempt to bend cable forcibly. Doing so increases effort required to unlock hood.
- Bumper finisher: It is made of plastic, so do not use excessive force and take care to keep oil away from it.

Hood lock adjustment

- Adjust hood so that hood primary lock meshes at a position where hood is 1 to 1.5 mm (0.039 to 0.059 in) lower than fender.
- After hood lock adjustment, adjust bumper rubber.
- When securing hood lock, ensure it does not tilt. Striker must be positioned at the center of hood primary lock.
- After adjustment, ensure that hood primary and secondary lock operate properly.

Hood lock secondary latch hooking length

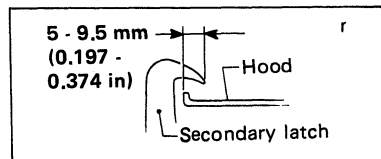

Hood hinge

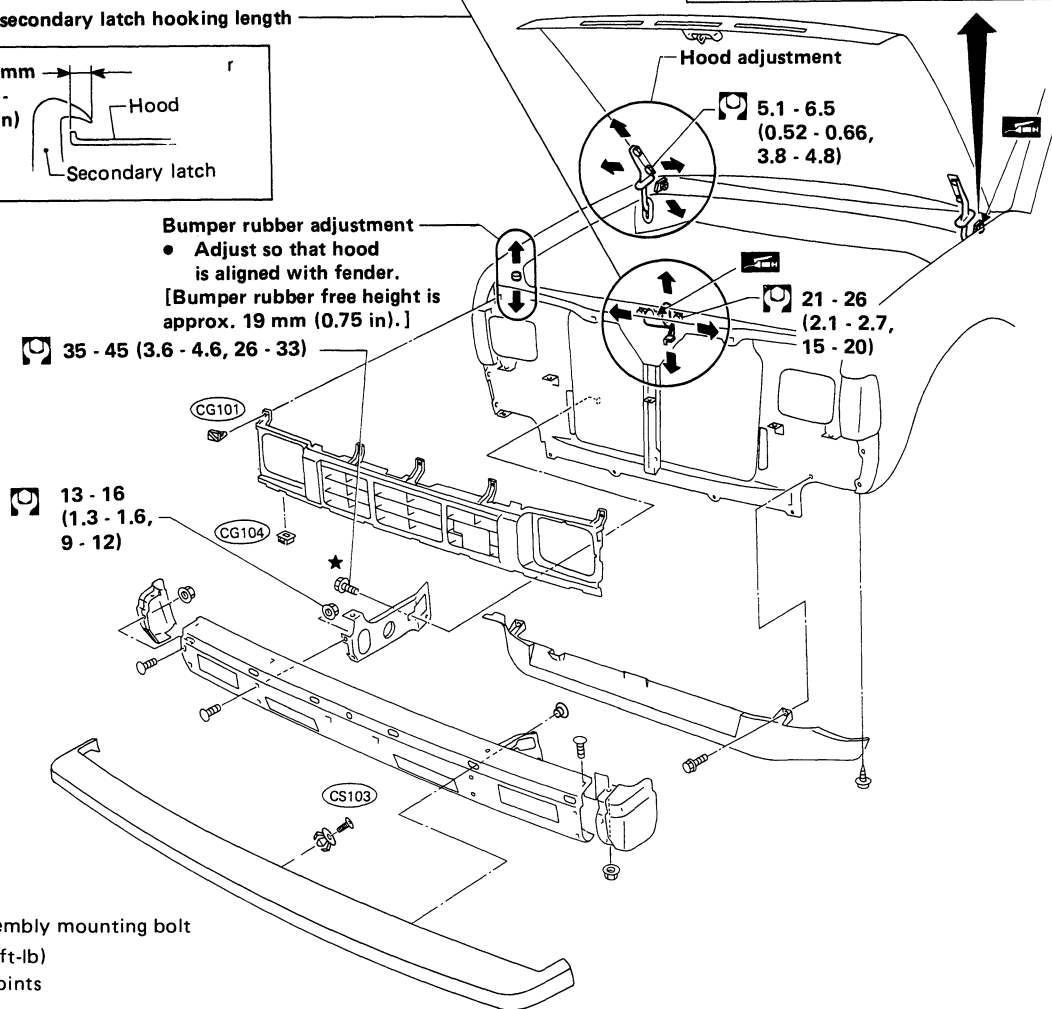
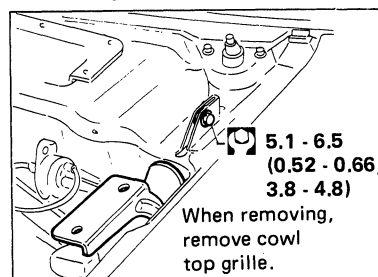

★: Bumper assembly mounting bolt

: N·m (kg-m, ft-lb)

: Grease-up points

BODY END

Rear End—TRUCK

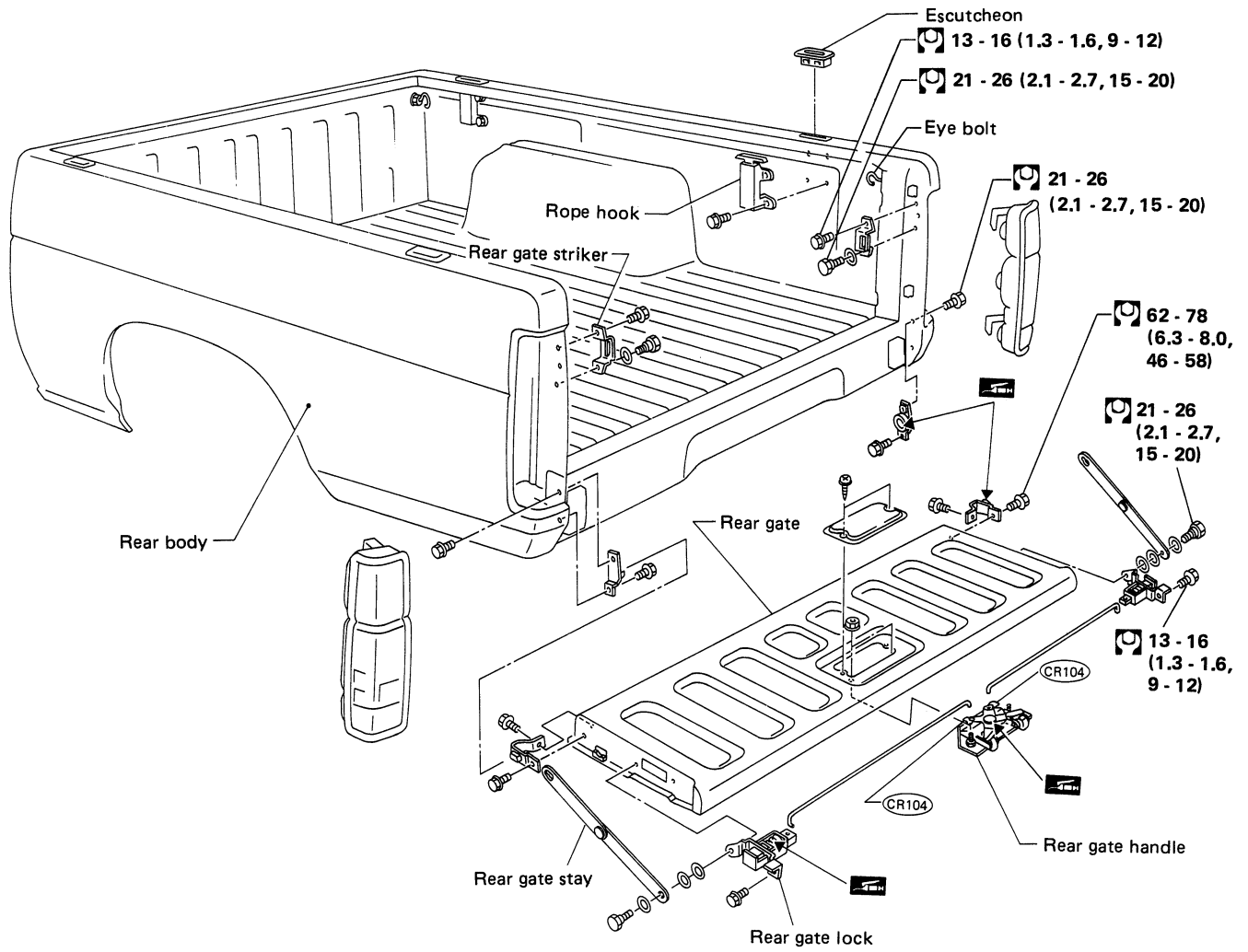

: N·m (kg·m, ft·lb)
 : Grease-up points

SBF273E

BODY END

Body Rear End—VAN & WAGON

- Back door lock system adjustment: Adjust lock & striker so that they are in the center.
After adjustment, check back door lock operation.
- Back door hatch lock system adjustment: Adjust lock & striker so that they are in the center.
After adjustment, check back door hatch lock operation.

WARNING:

- Be careful not to scratch back door stay and/or back door hatch stay when installing back door and/or back door hatch. A scratched stay may cause gas leakage.
- The contents of the back door stay and back door hatch stay are under pressure. Do not take apart, puncture, apply heat or allow fire near them.

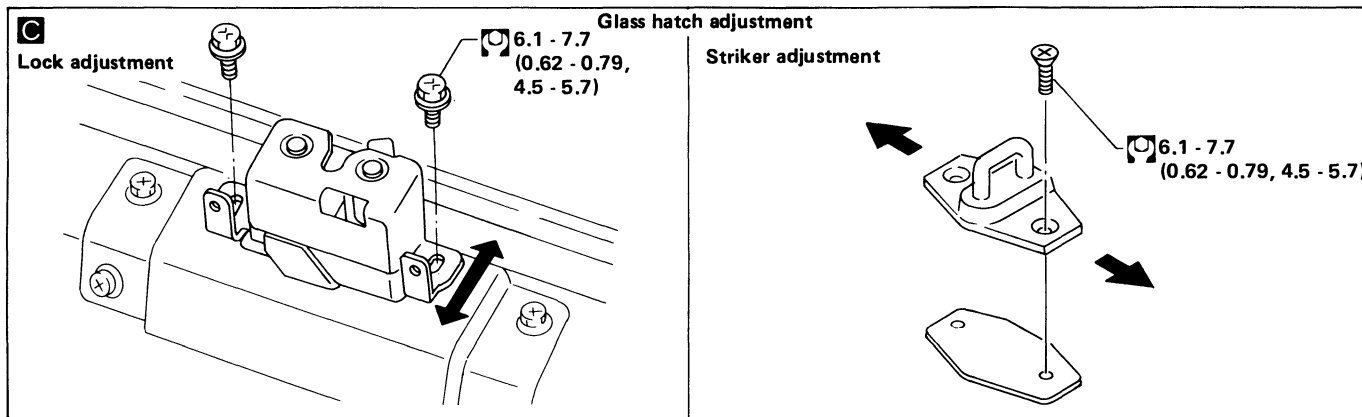
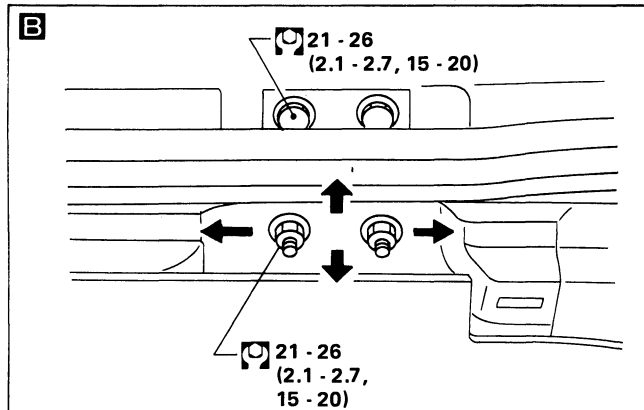
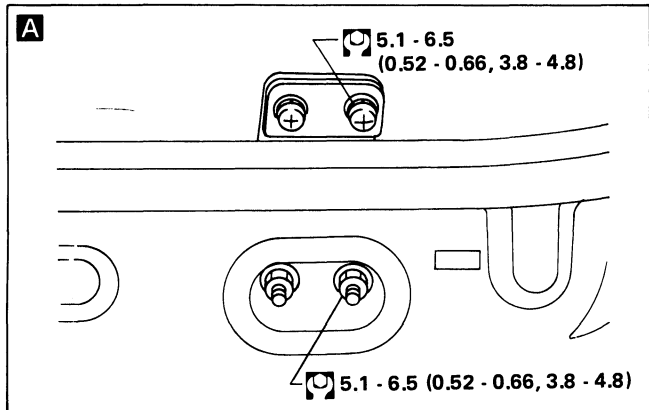

BODY END

Body Rear End—VAN & WAGON (Cont'd)

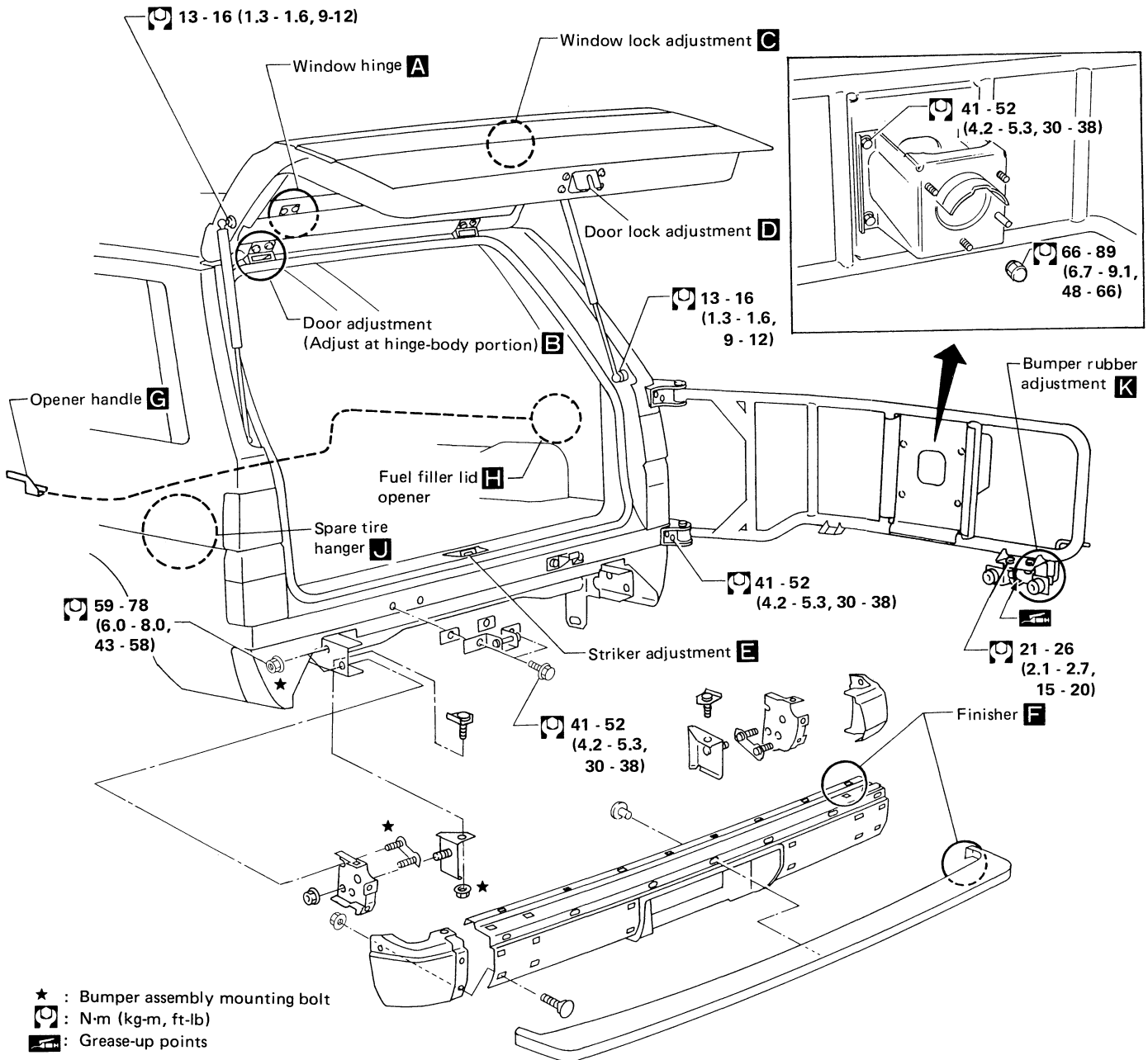
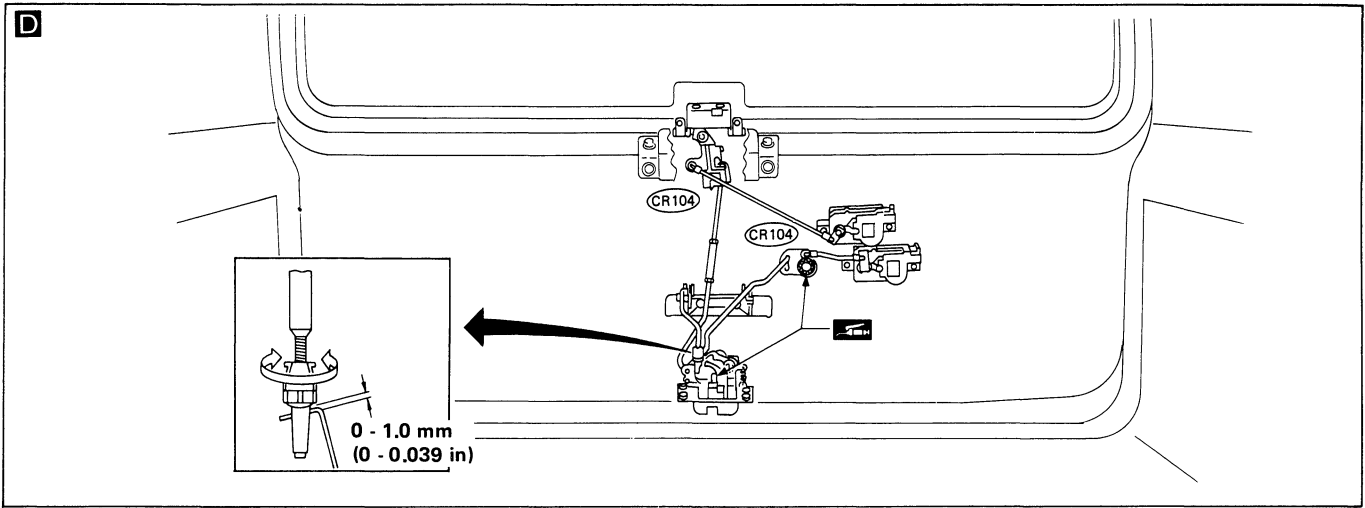

BODY END

Body Rear End—VAN & WAGON (Cont'd)

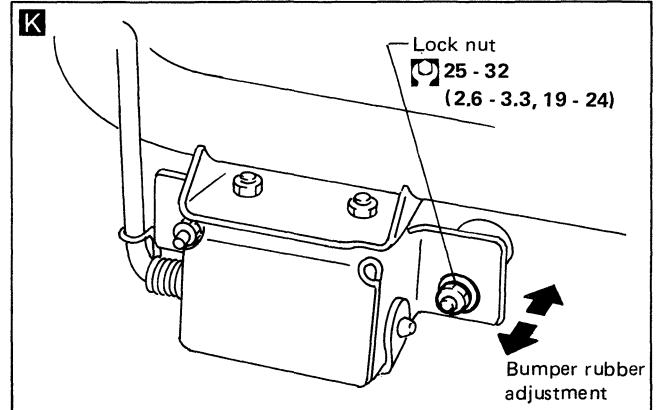
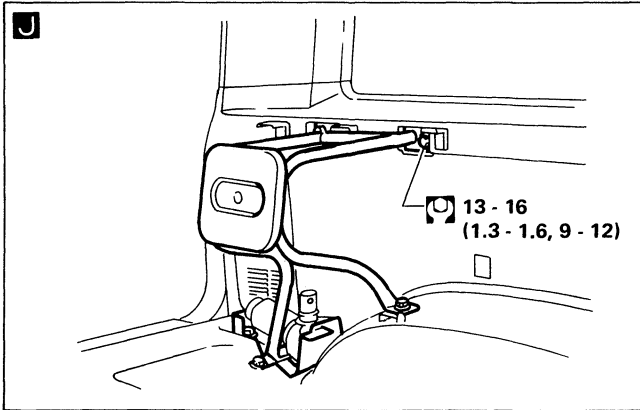
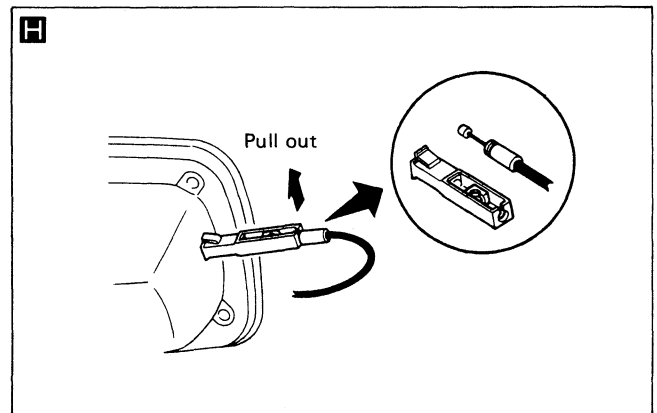
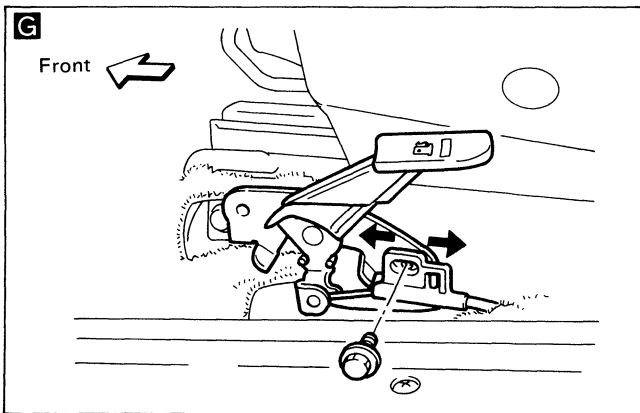
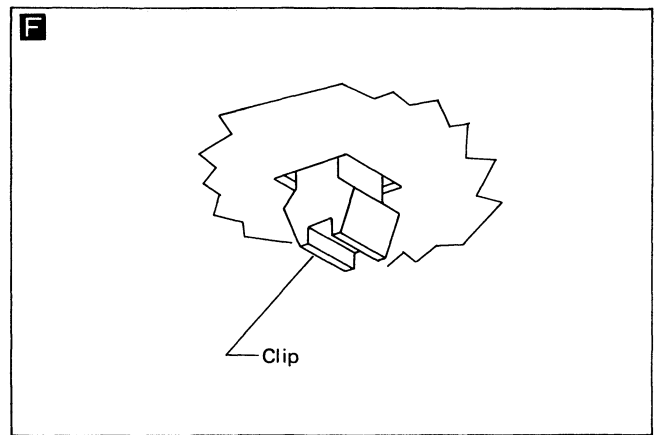
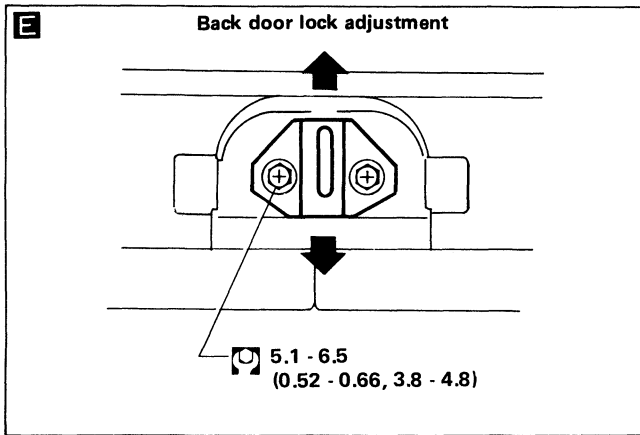

: N·m (kg·m, ft·lb)

SBF274E

Back Door Window Opener—WAGON

WIRING DIAGRAM

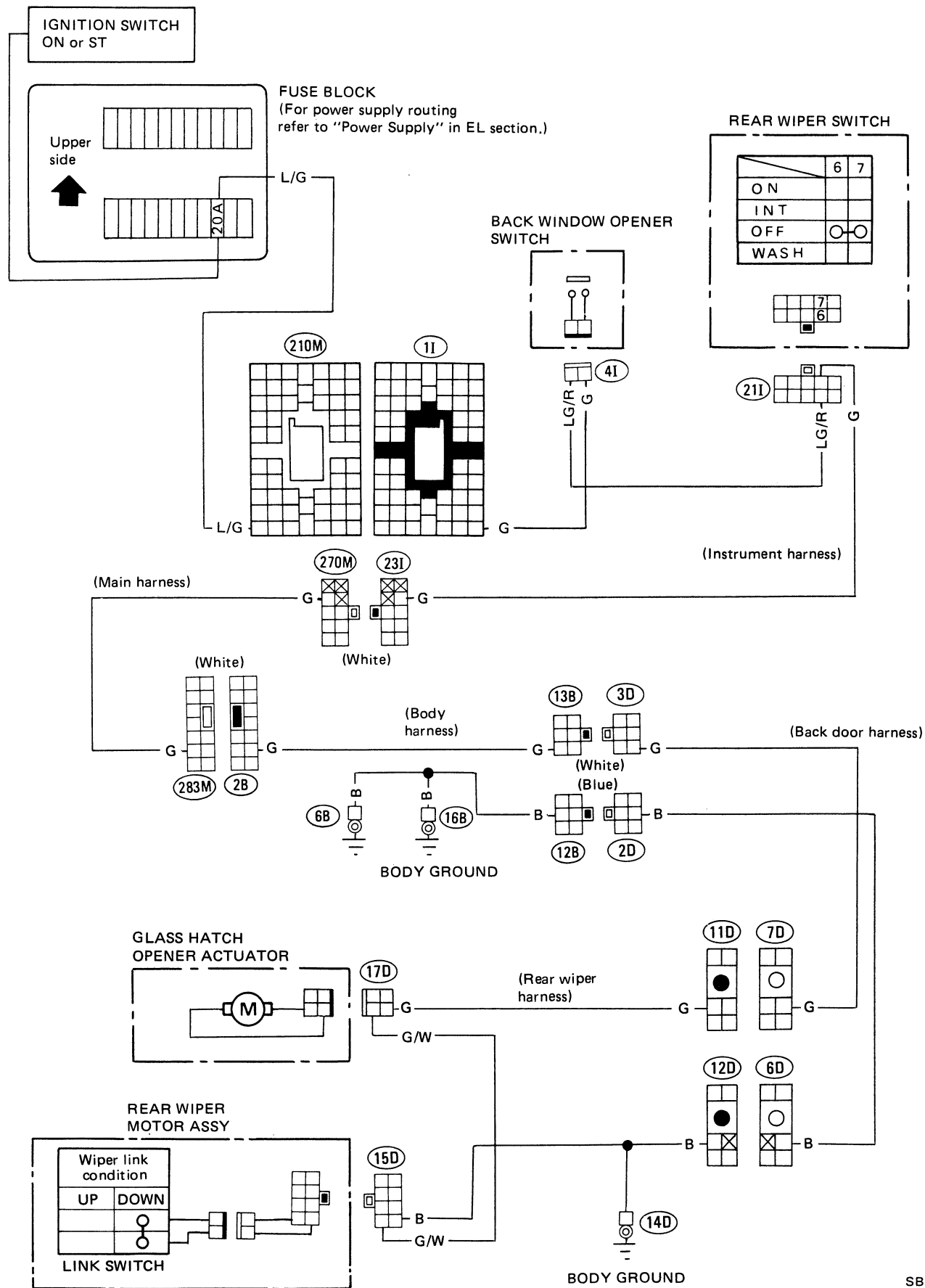

SBF794D

DOOR

Door

- After adjusting door or door lock, make sure door locks properly.

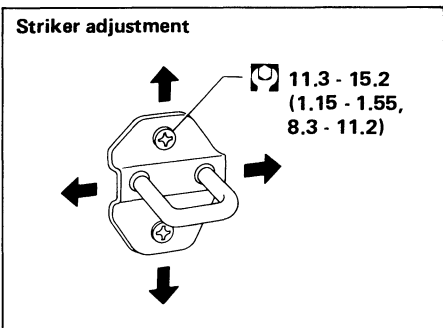
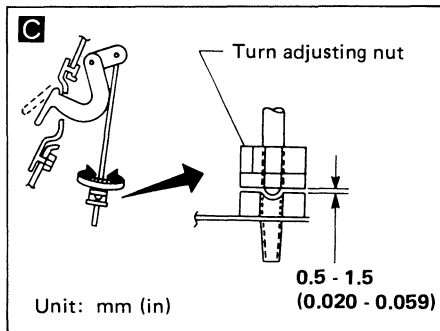
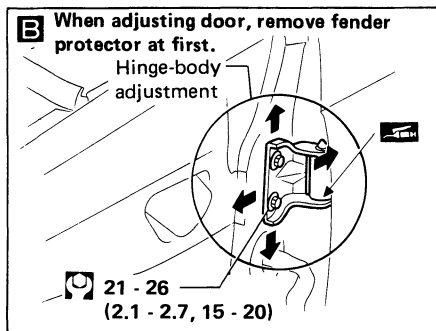
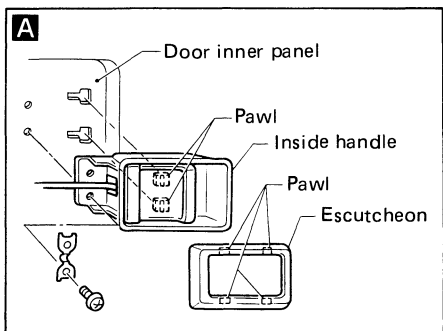
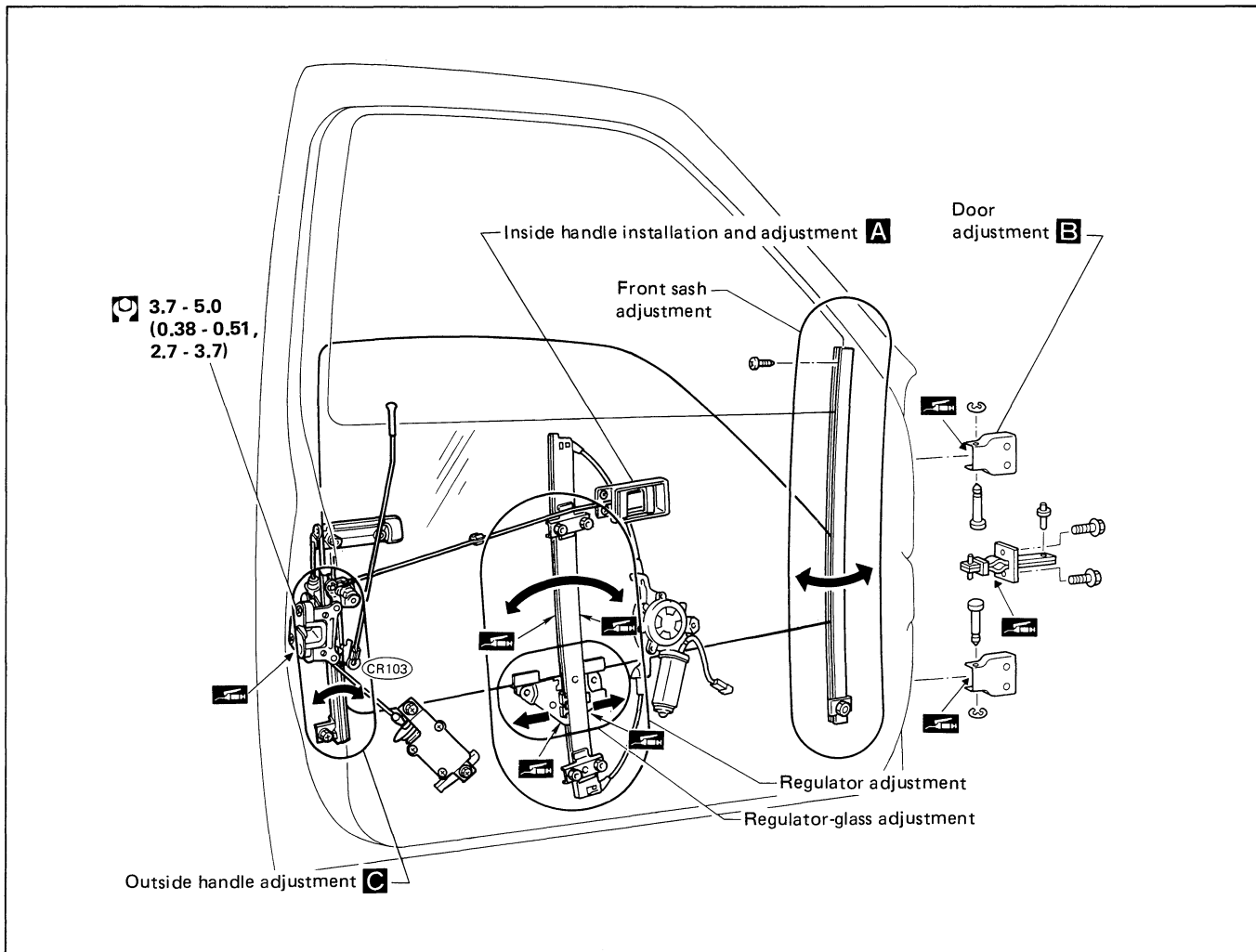

: N·m (kg·m, ft·lb)
 : Grease-up points

DOOR

NOTE

DOOR

Power Door Lock

- When Lock-Unlock (Unlock-Lock) is repeated more than two or three times rapidly using the door lock-&-unlock switch connected to driver side door lock knob, the door may either be locked or unlocked by itself, or the actuator may not be activated. This depends on the Lock-Unlock operation period and other conditions.
Avoid this type of operation as a system fault may occur.

WIRING DIAGRAM

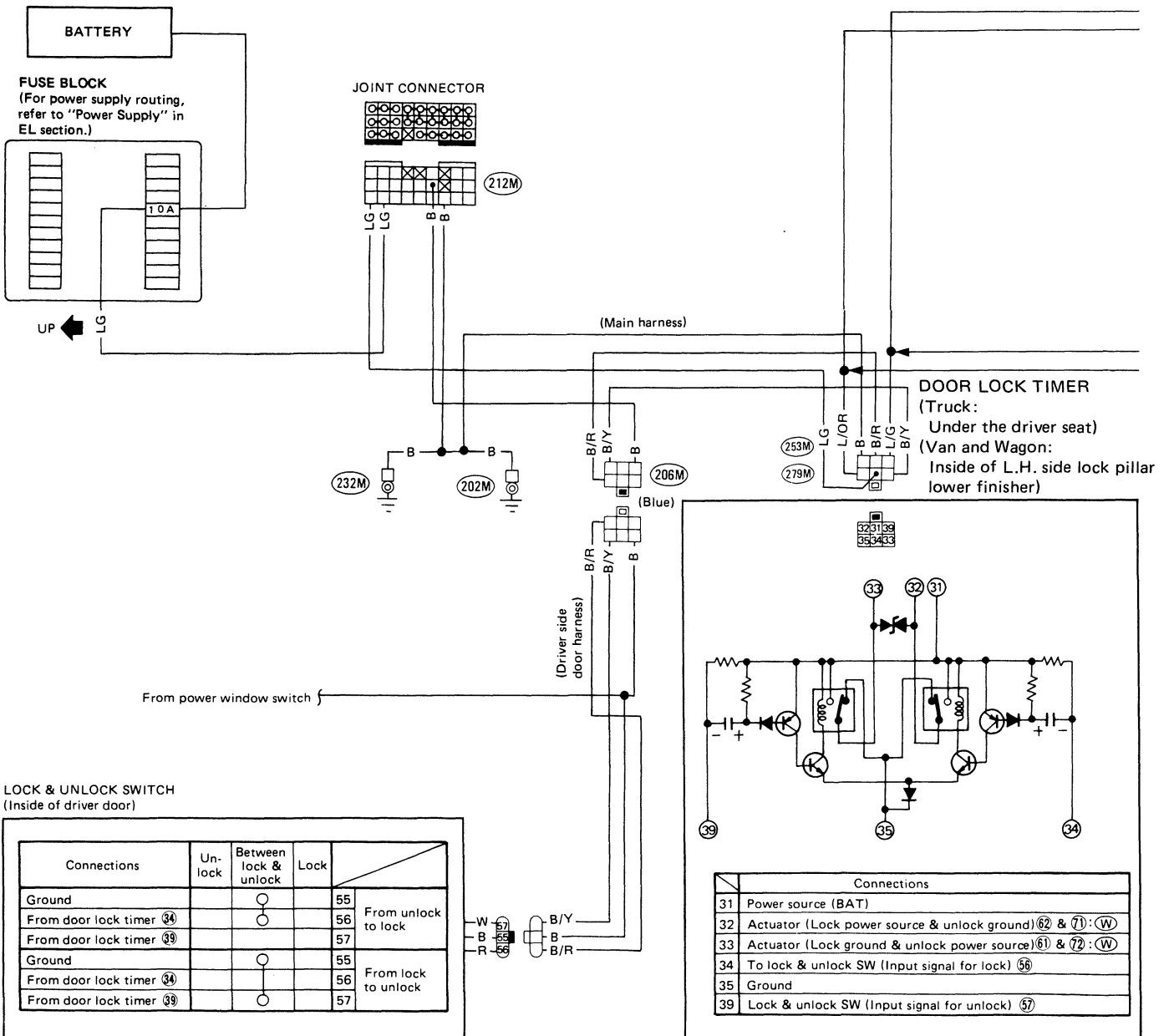

DOOR

Power Door Lock (Cont'd)

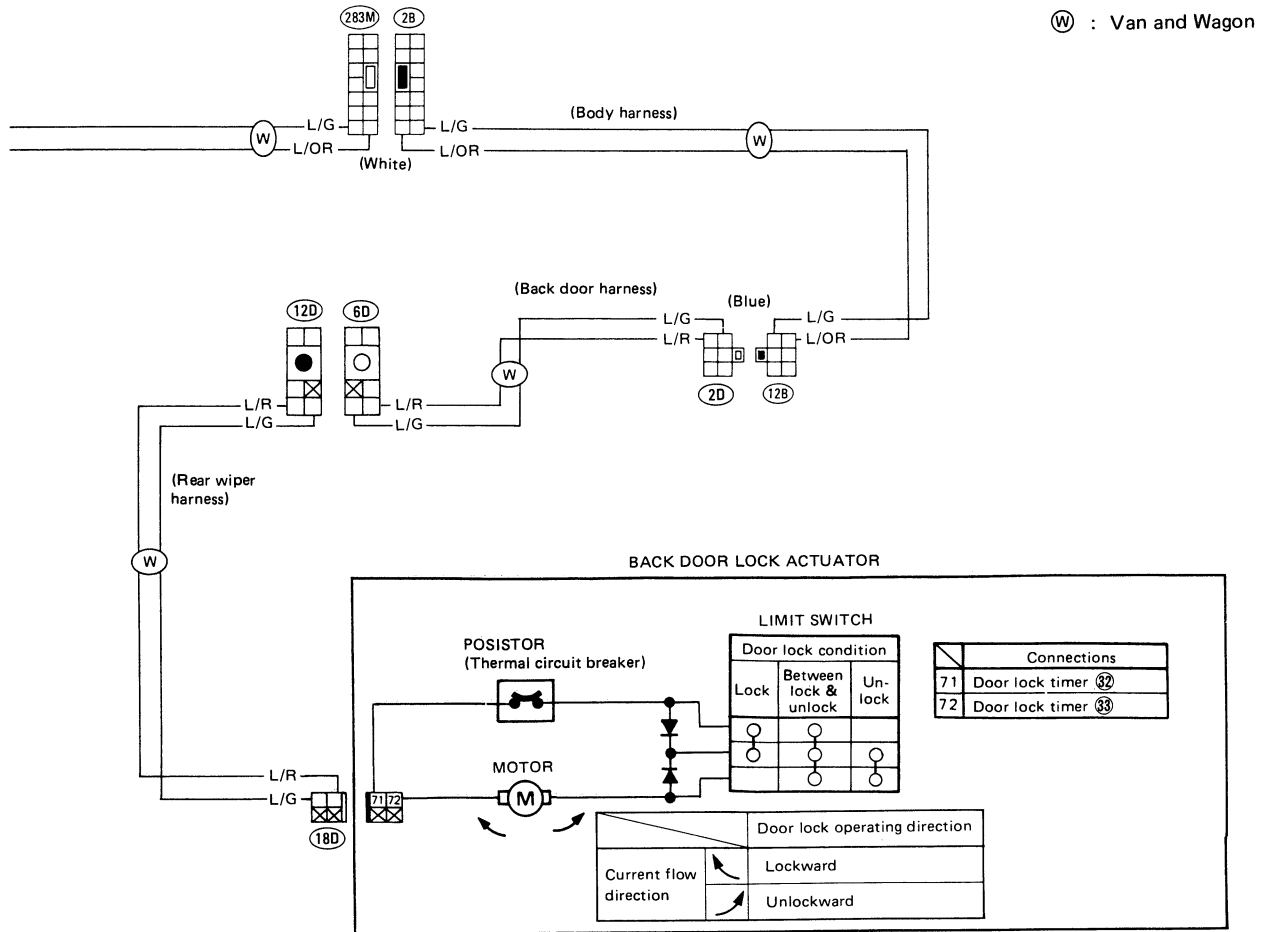
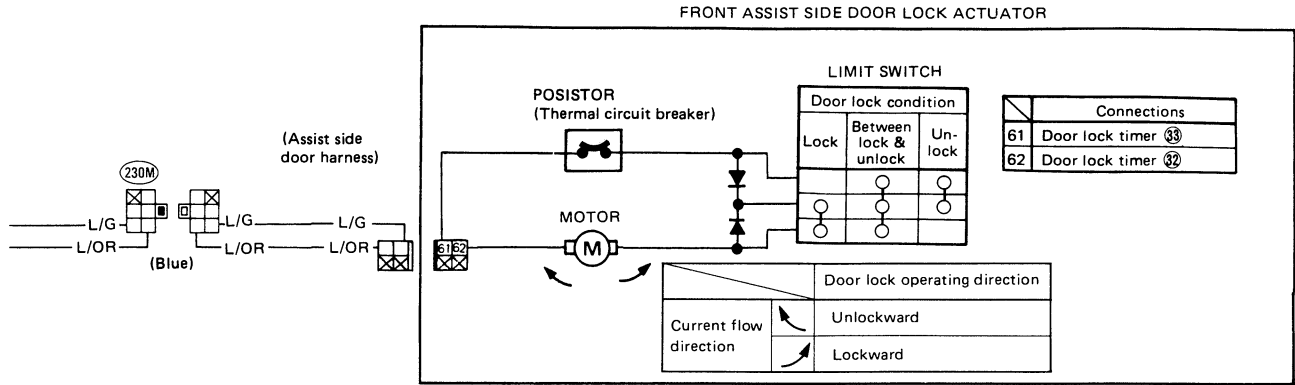

Ⓜ : Van and Wagon

DOOR

Power Door Lock (Cont'd)

Door lock timer inspection

OPERATION

Input signal	SW-A operation	OFF	Turns ON	ON	Turns OFF	OFF	OFF	OFF	Turns ON	Turns OFF
	SW-B operation	OFF	OFF	OFF	OFF	Turns ON	ON	Turns OFF	After SW-A operation, immediately turns ON	Turns OFF
Output signal	Test lamp operation	OFF	ON (Approx. 1.0 sec) → OFF	OFF	OFF	ON (Approx. 1.0 sec) → OFF	OFF	OFF	ON → OFF → ON → OFF	OFF

- Carry out the inspection in this chart from left to right continuously.

Lighting period of test lamp differs according to SW-B operation. Moreover, test lamp may come on once or it may not come on at all. If this occurs, do not judge it faulty solely from this step.

- Do not carry out any switch operations that are not described in the above chart to avoid breaking door lock timer.

INSPECTION CIRCUIT (This test circuit must be wired by the technician.)

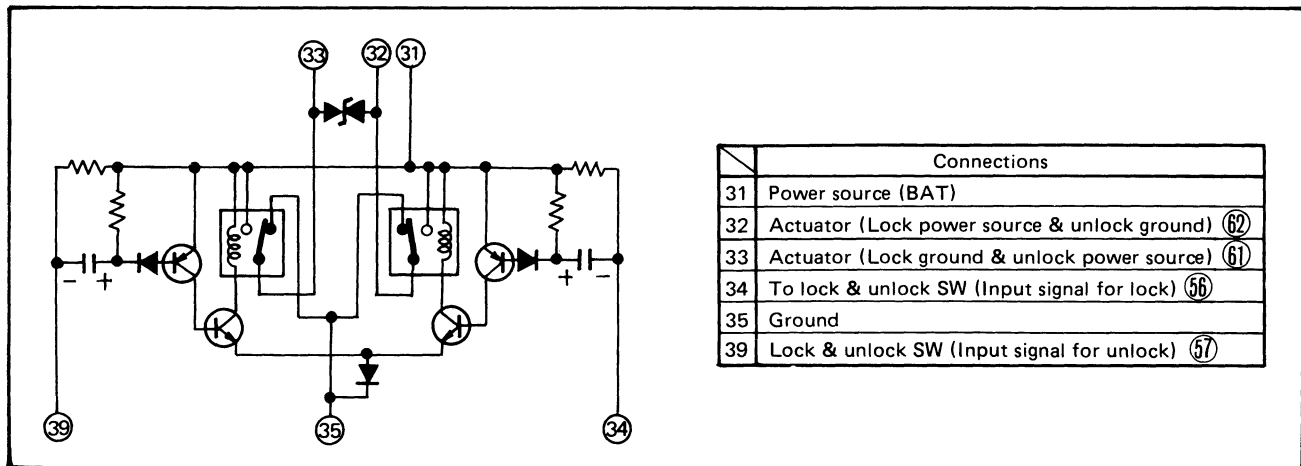
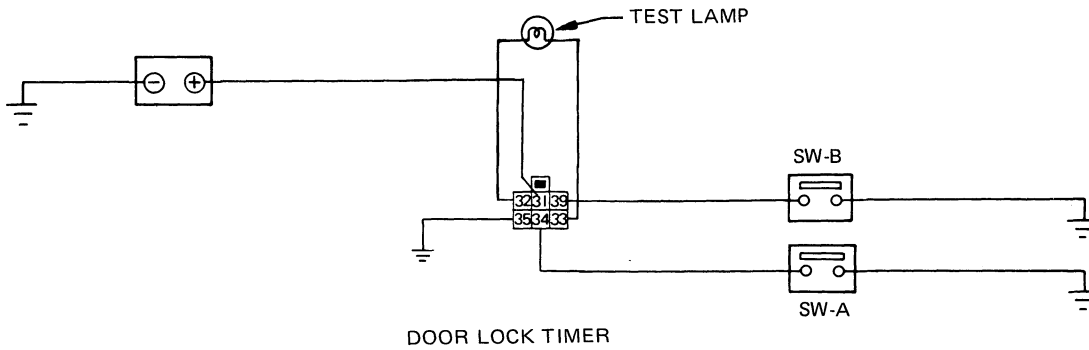

SBF327C

Power Window

WIRING DIAGRAM

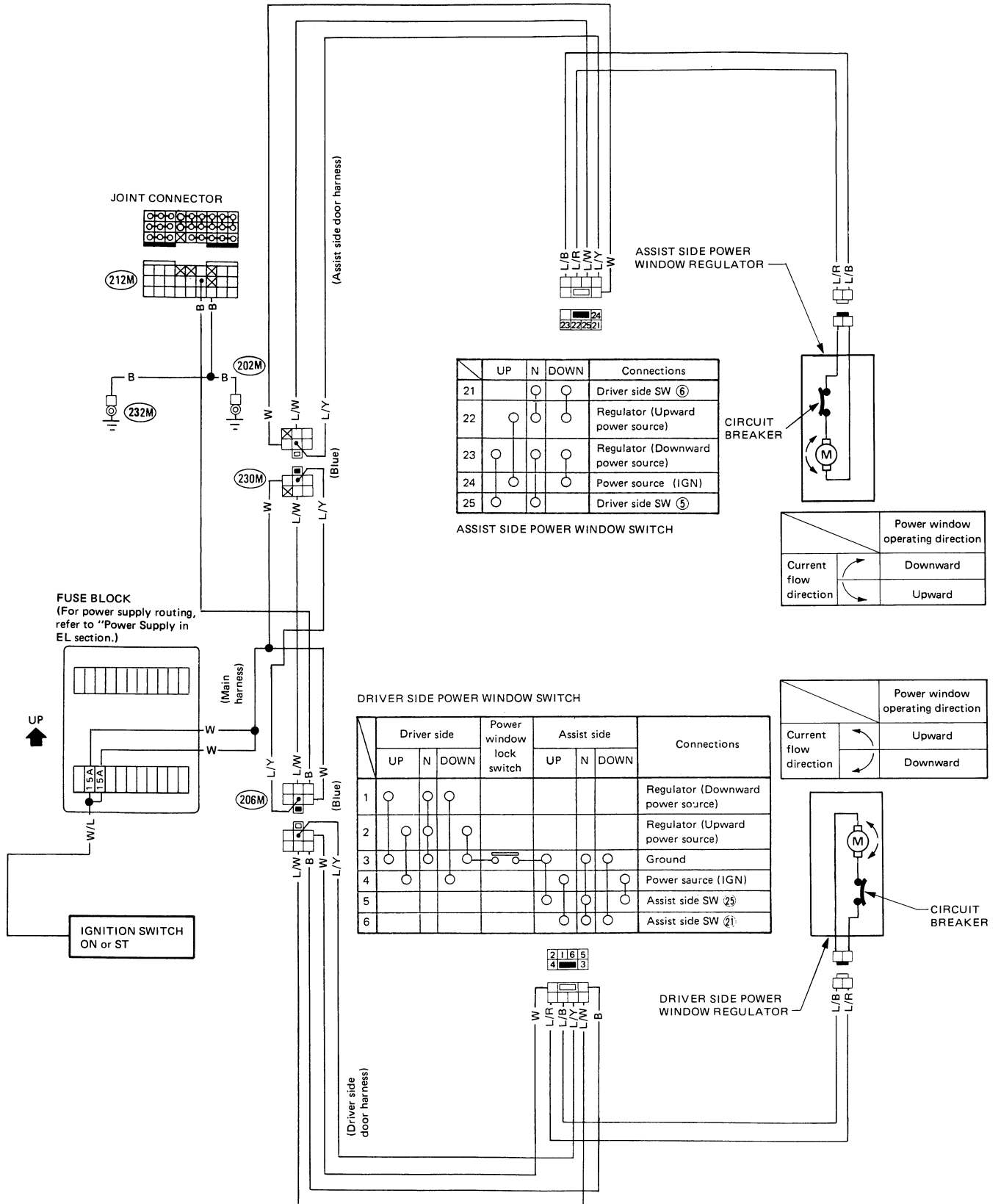

INTERIOR AND EXTERIOR

Interior—TRUCK

- Apply sealing compound where necessary while installing parts.
- When applying sealing compound, be careful that the sealing compound does not protrude from parts.

SIDE AND FLOOR TRIM – Passenger room

King Cab

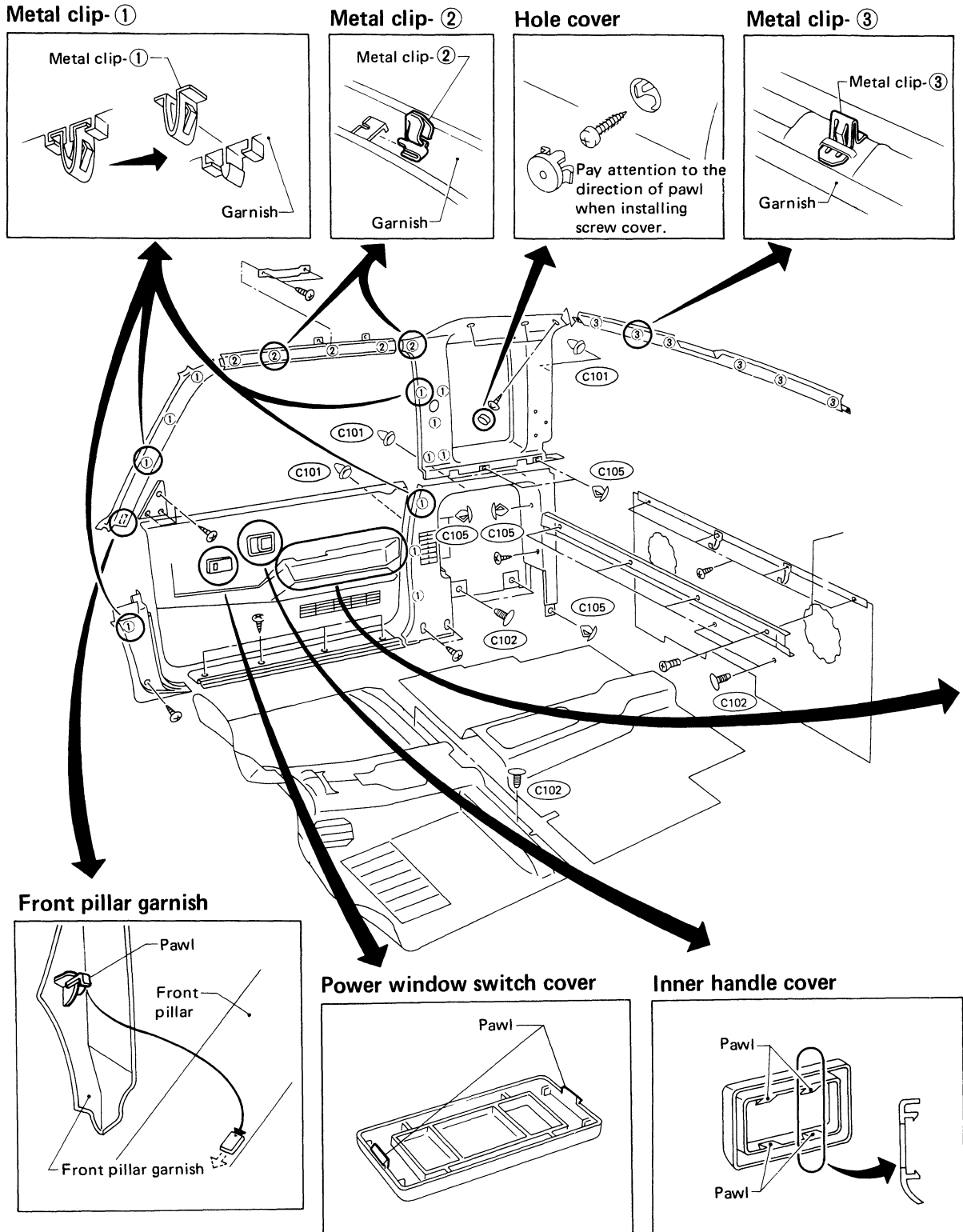

INTERIOR AND EXTERIOR

Interior—TRUCK (Cont'd)

Door arm rest

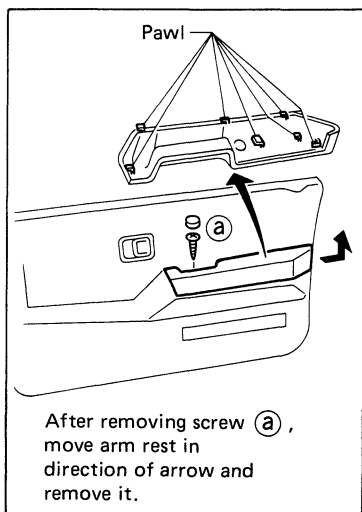

Regular cab-Basically the same as King Cab

Center pillar garnish - Type I

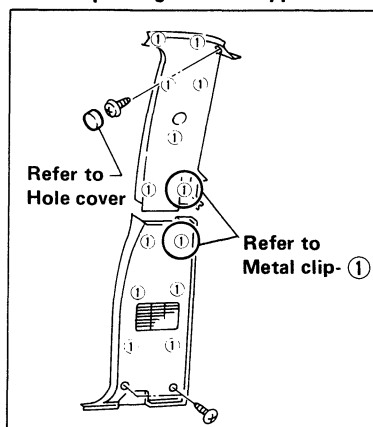

Center pillar garnish - Type II

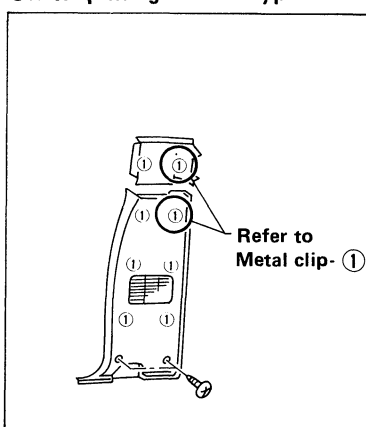

INTERIOR AND EXTERIOR

Interior—TRUCK (Cont'd)

ROOF TRIM – Type I

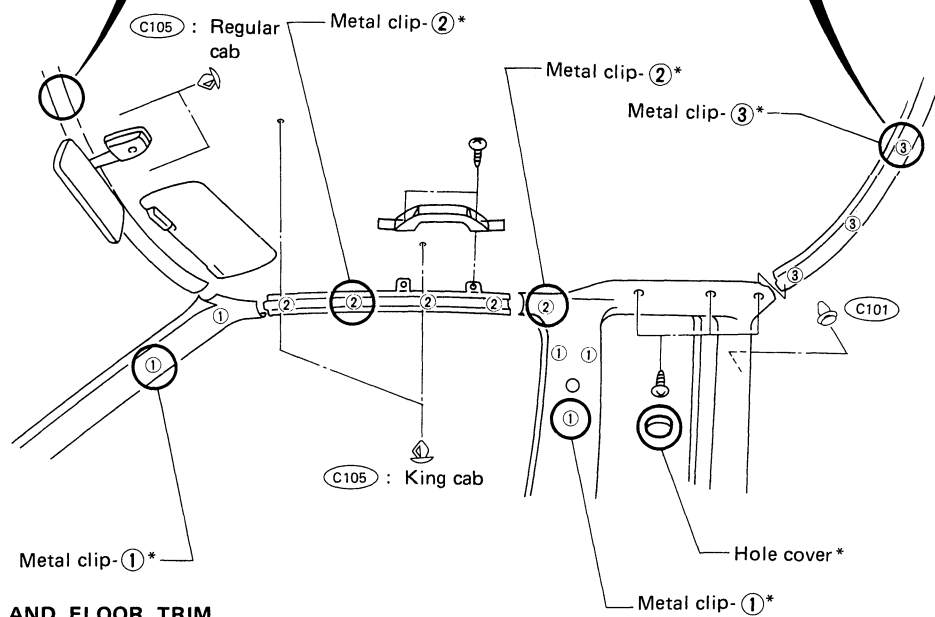
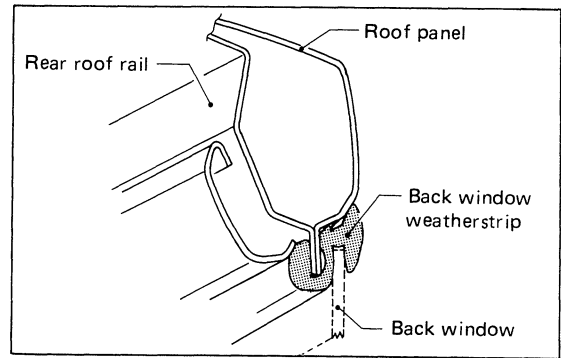
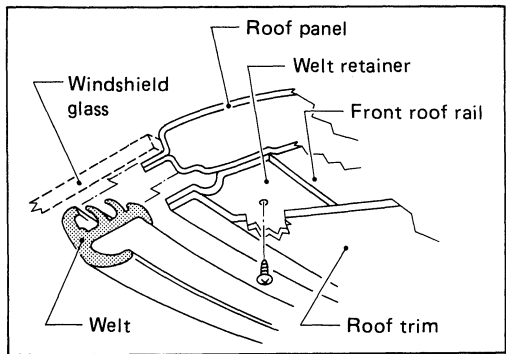

*: Refer to SIDE AND FLOOR TRIM.

SBF312D

INTERIOR AND EXTERIOR

Interior—TRUCK (Cont'd)

ROOF TRIM – Type II

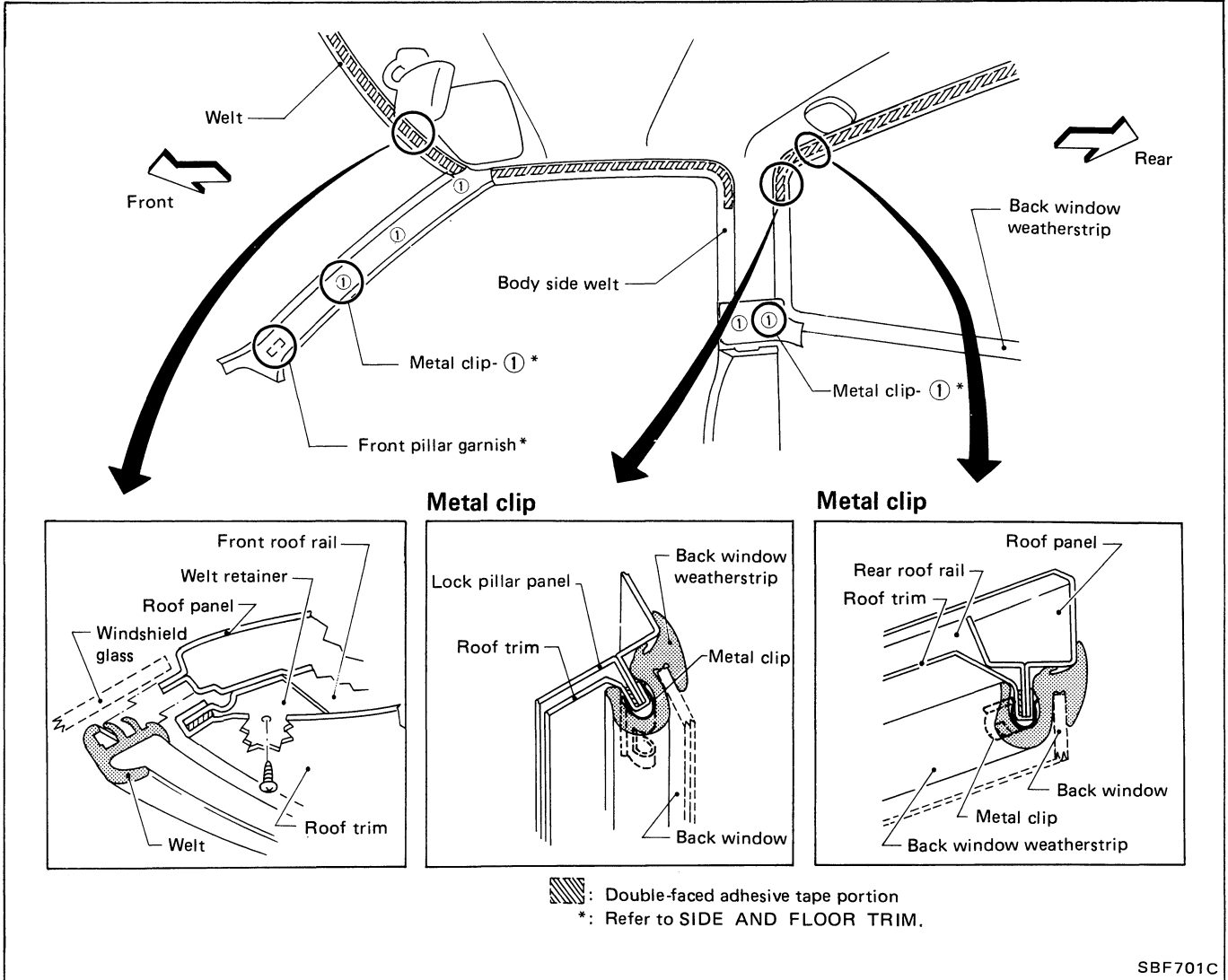

Roof trim installation

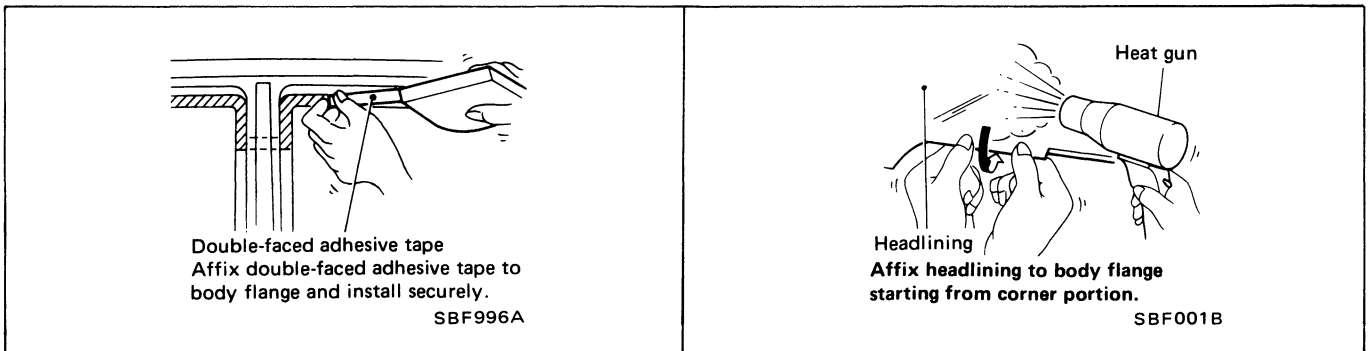



INTERIOR AND EXTERIOR

Interior—VAN & WAGON

- Apply sealing compound where necessary while installing parts.
- When applying sealing compound, be careful that the sealing compound does not protrude from parts.

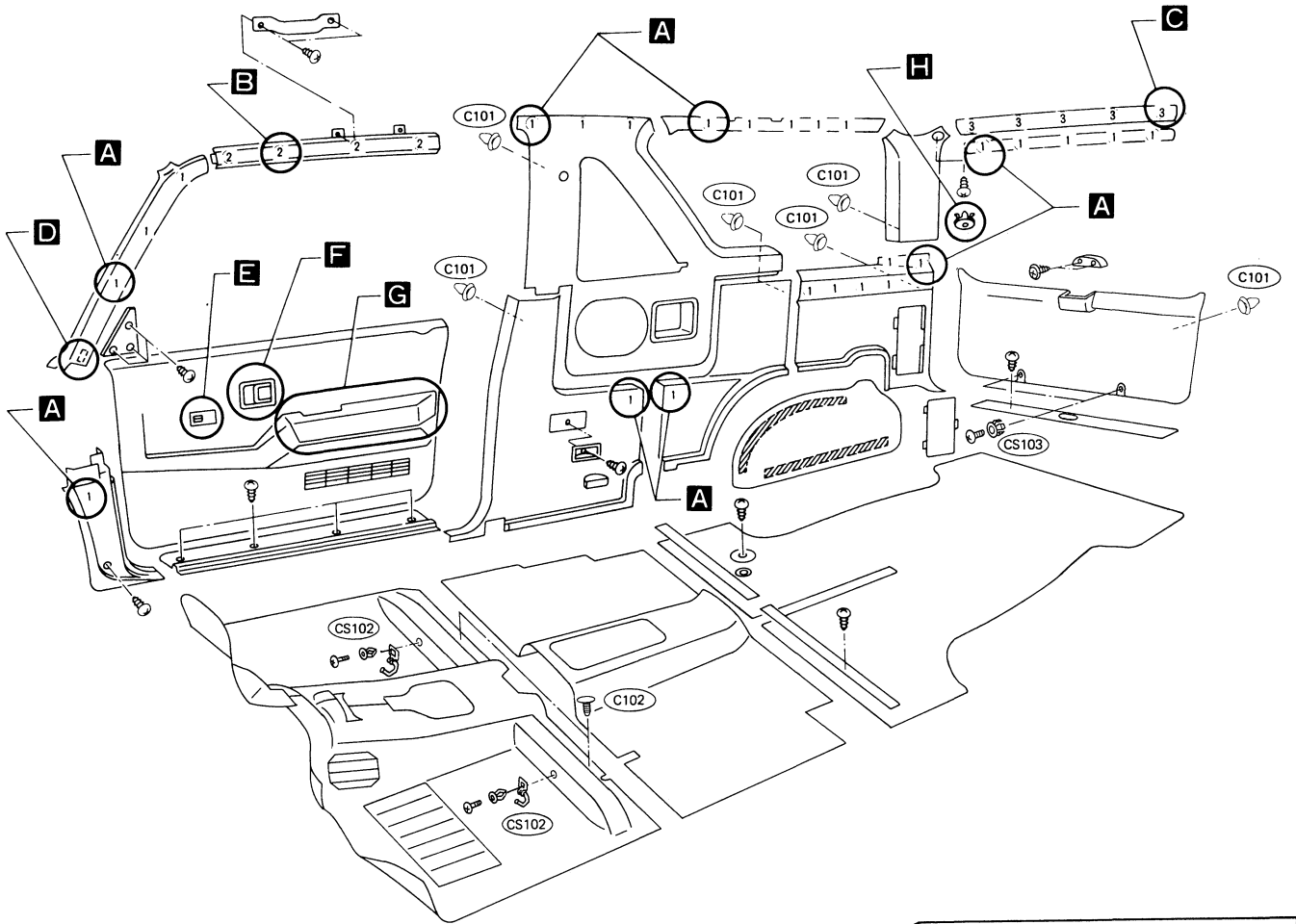
SIDE AND FLOOR TRIM



 Double-faced adhesive tape

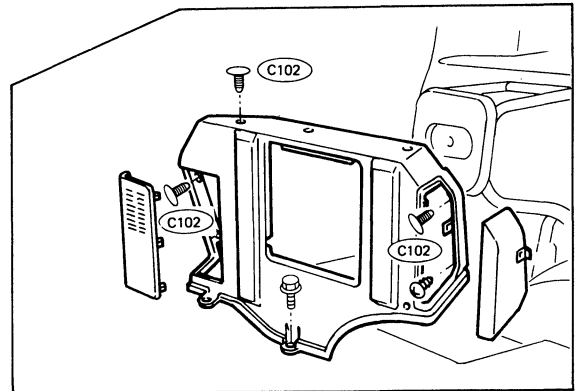

INTERIOR AND EXTERIOR

Interior—VAN & WAGON (Cont'd)

Metal clip- ①

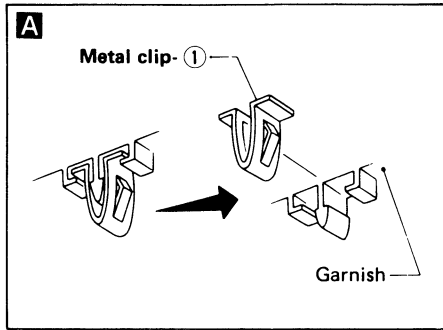

Metal clip- ②

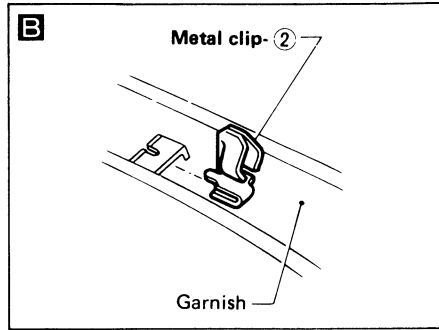

Door arm rest

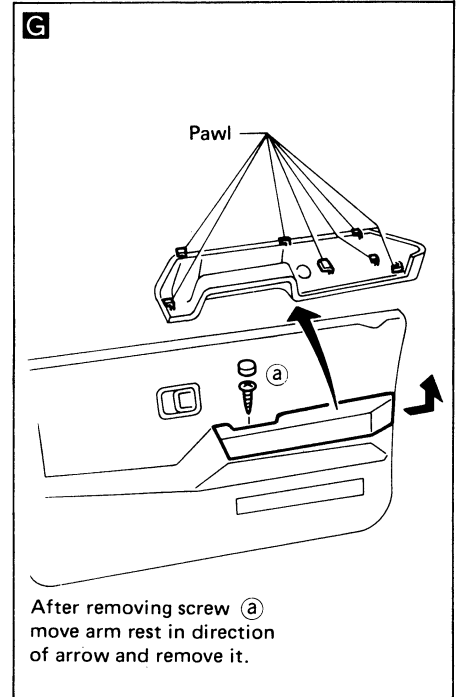

Metal clip- ③

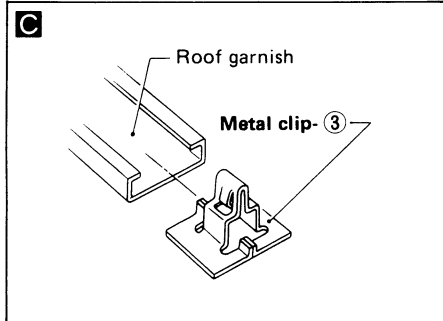

Front pillar garnish

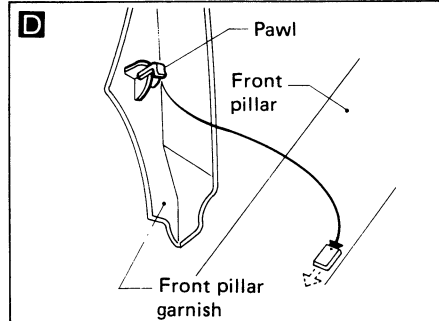

Power window switch

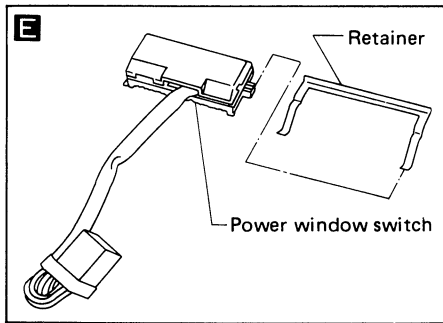

Inner handle cover

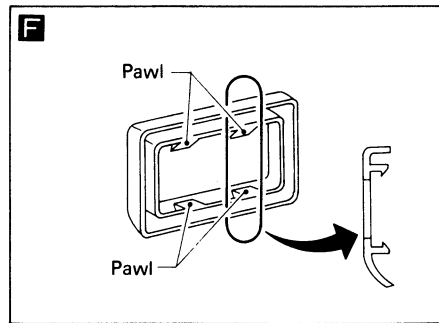

Hole cover

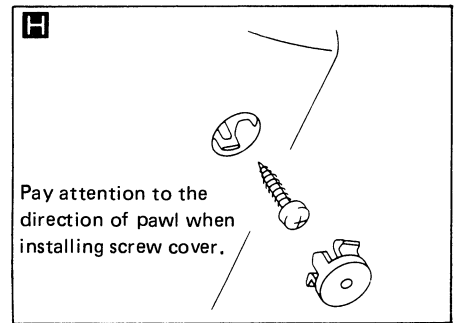

SBF277E

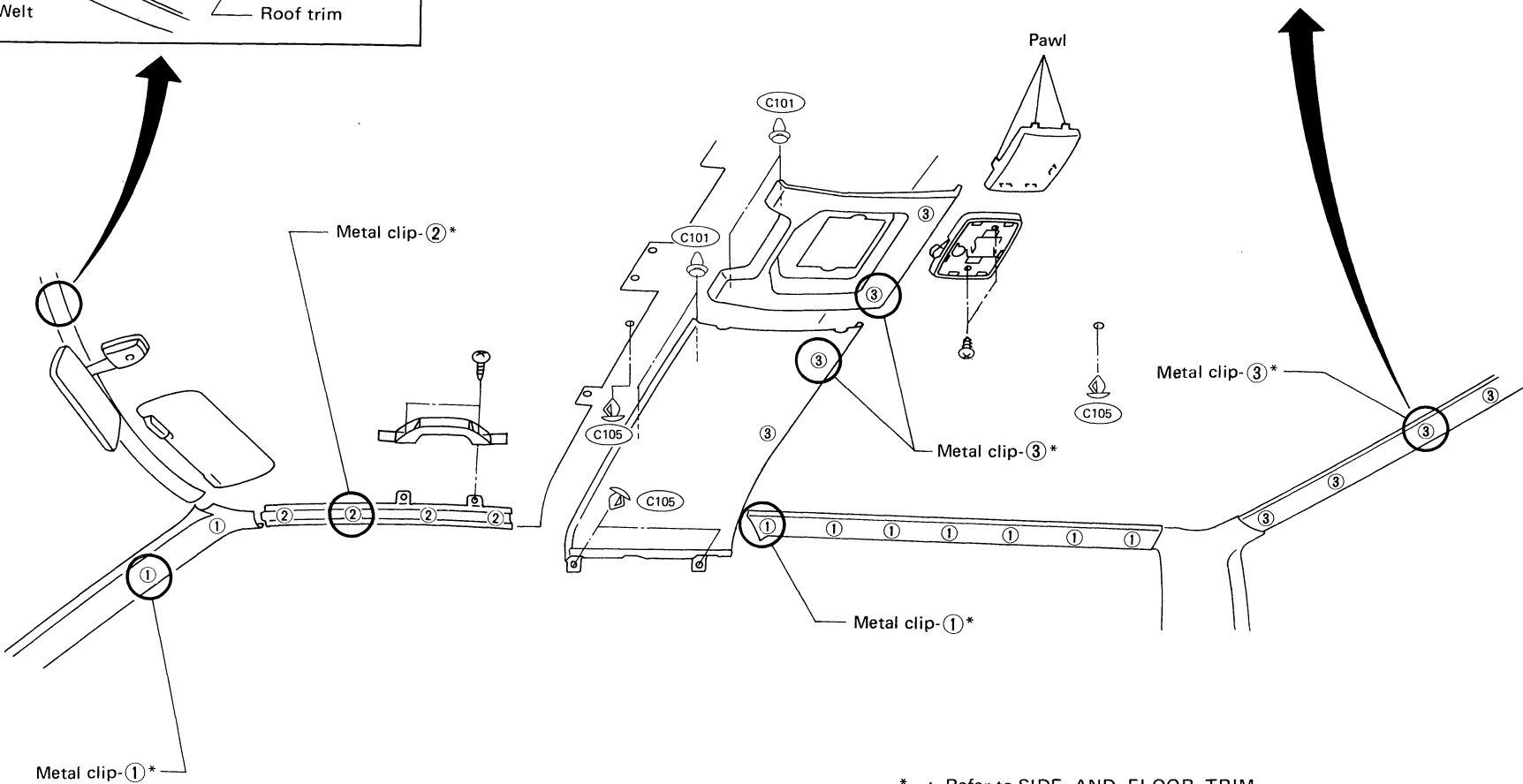
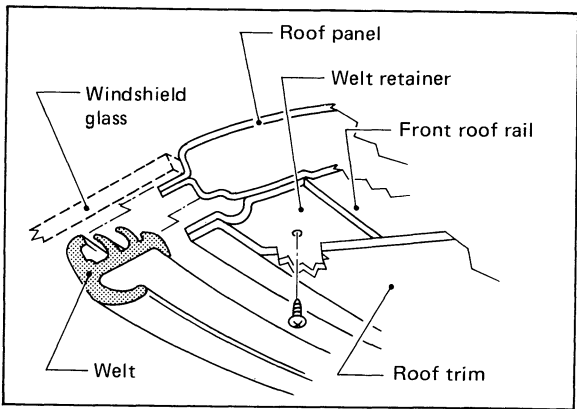
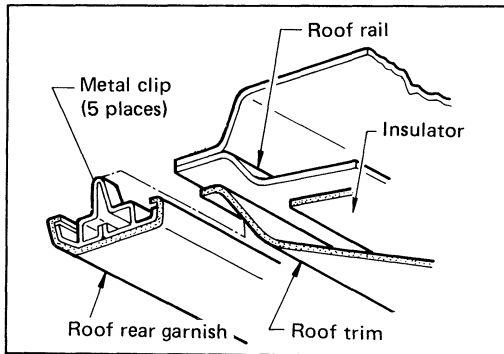

* : Refer to SIDE AND FLOOR TRIM

INTERIOR AND EXTERIOR

Exterior—TRUCK

- Apply sealing compound where necessary while installing parts.
- When applying sealing compound, be careful that the sealing compound does not protrude from parts.

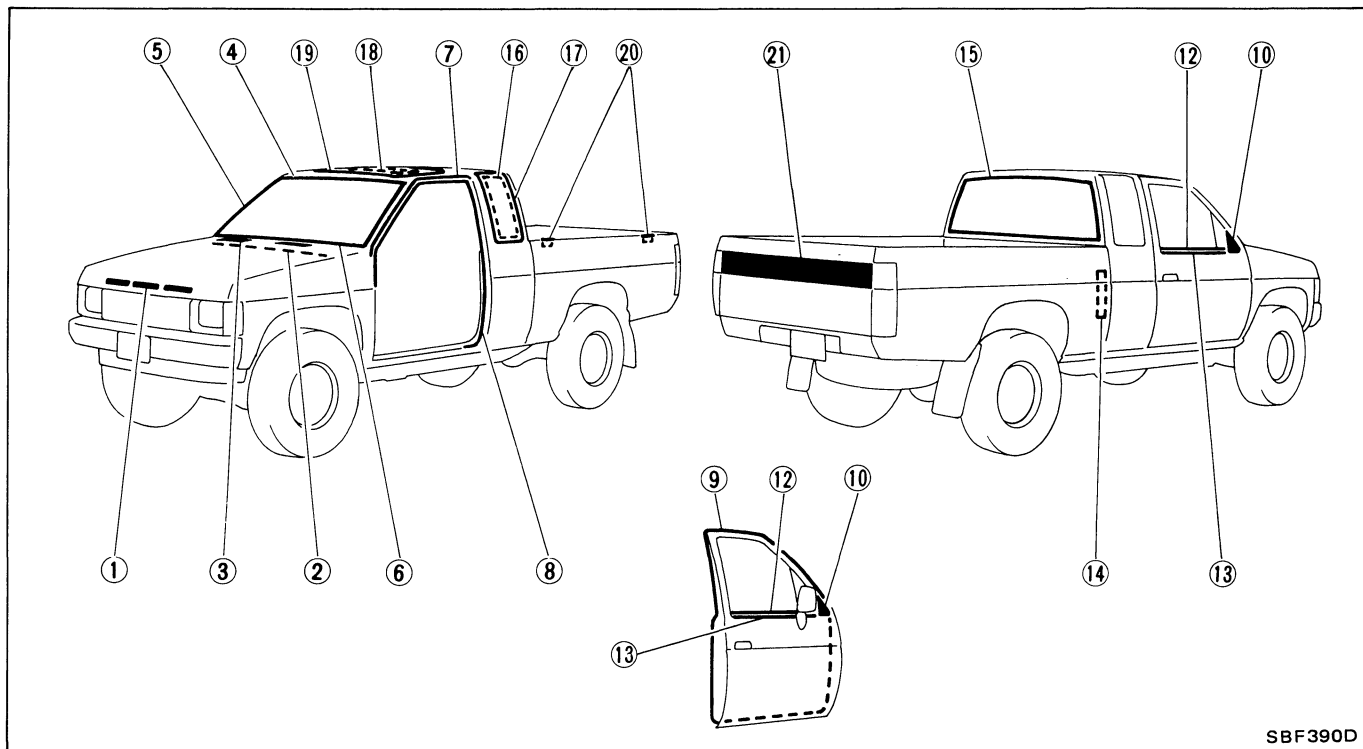

SBF390D

① Hood top air inlet grille

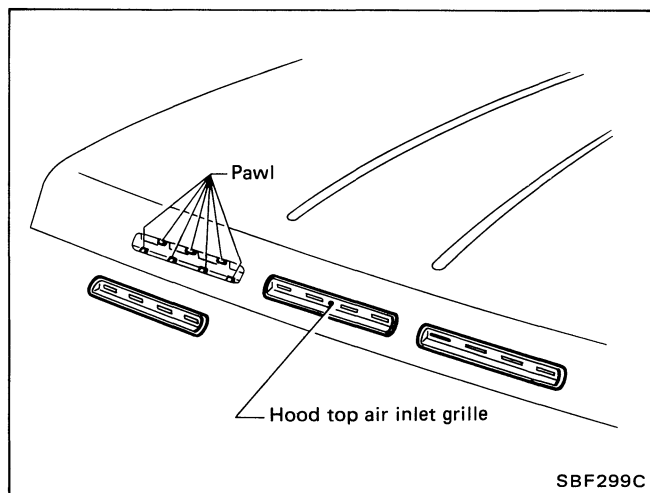

SBF299C

② ③ Cowl top sealing rubber & grille

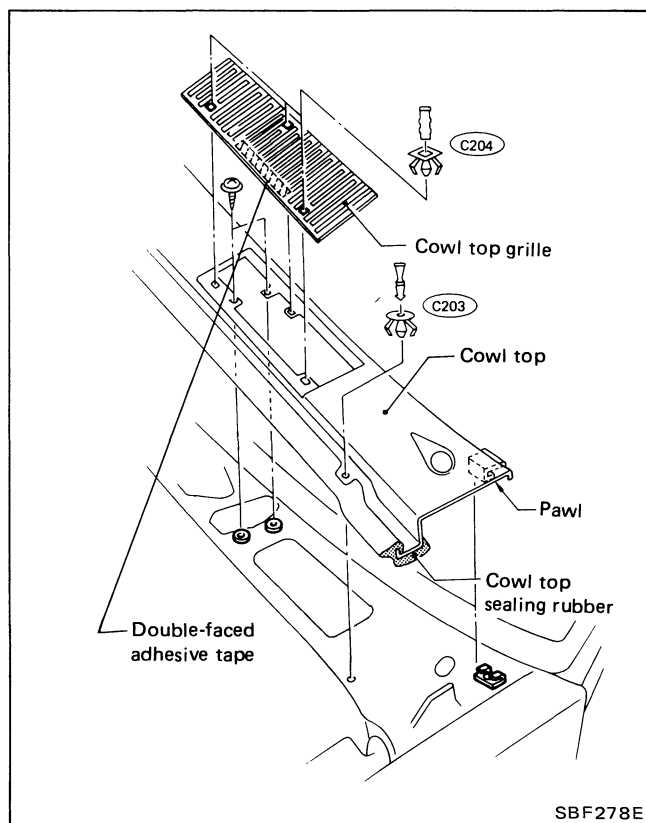

SBF278E

INTERIOR AND EXTERIOR

Exterior—TRUCK (Cont'd)

④ Windshield upper molding

Method 1

Cut off top portion of molding and clean glass and panel surfaces.

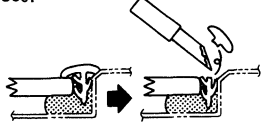

Apply sealant to top portion of molding.

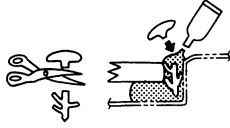

Cut off lower portion of new molding



Finish well to give it a good appearance.

Method 2

1. Cut off sealant at glass end.
2. Clean the side on which panel was mounted.
3. Set molding fastener and apply sealant & primer to body panel, and apply primer to molding.

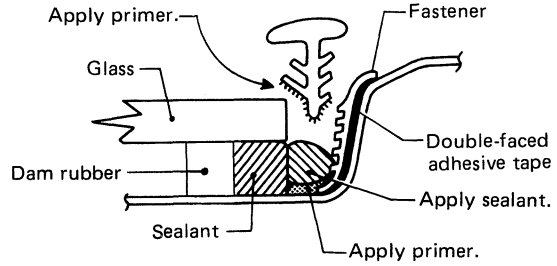

4. Install molding by aligning the molding mark located on center with vehicle center. Be sure to install tightly so that there is no gap around the corner.

SBF301C

⑤ ⑥ Windshield side & lower molding

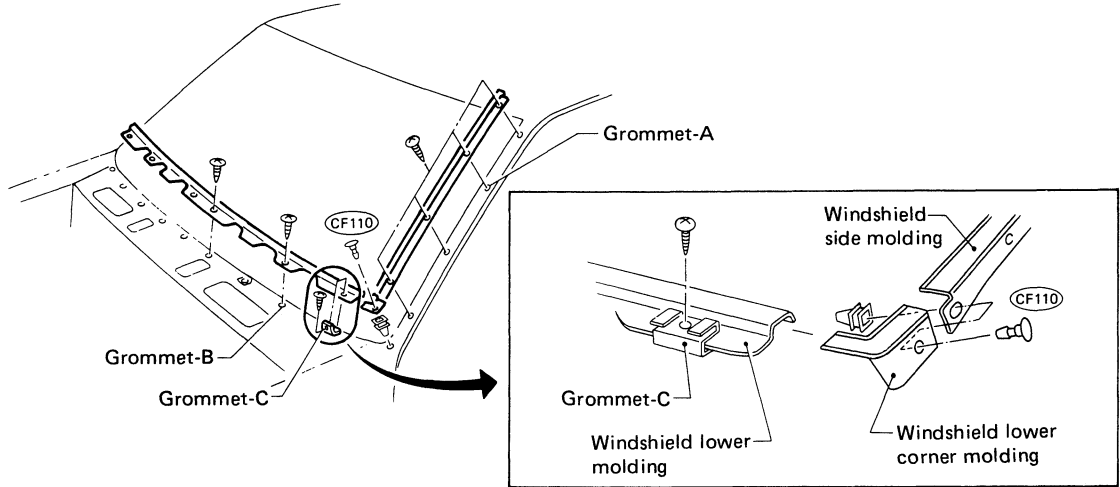

SBF781D

⑦ Drip weatherstrip

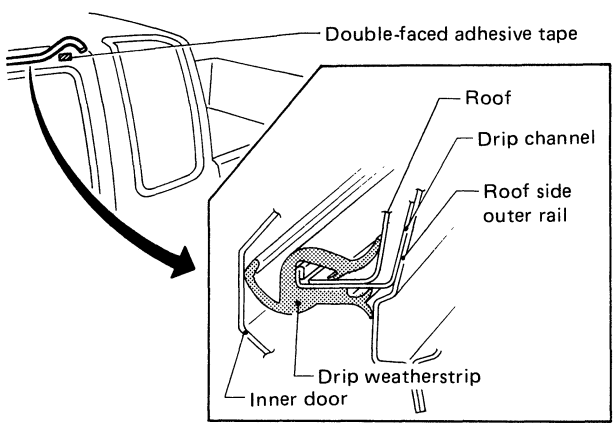

SBF303C

⑧ Body side welt

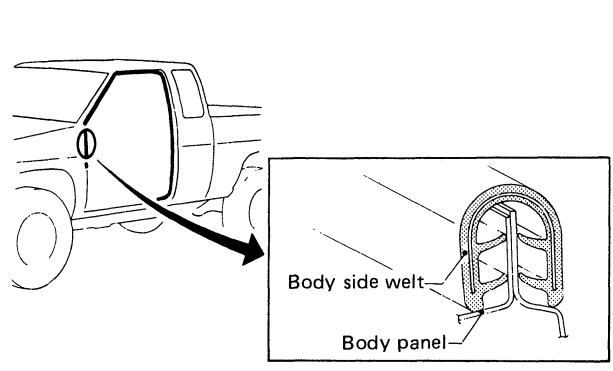

SBF810D

INTERIOR AND EXTERIOR

Exterior—TRUCK (Cont'd)

9 Door weatherstrip

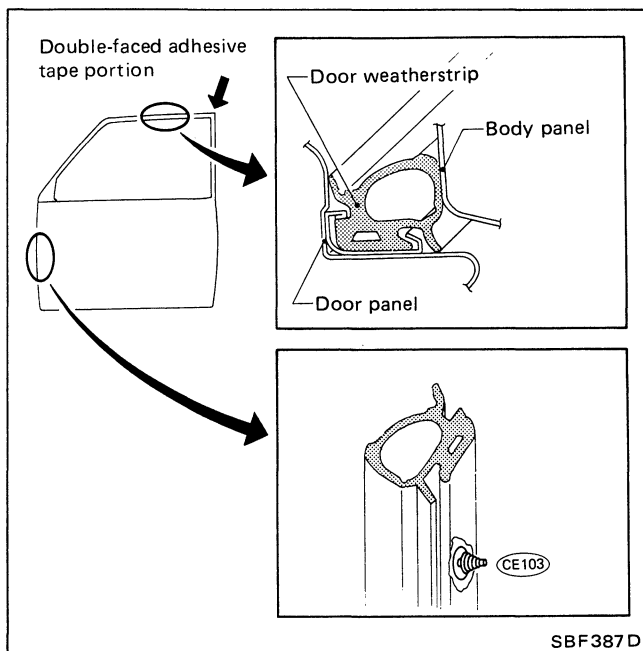

10 Door corner cover

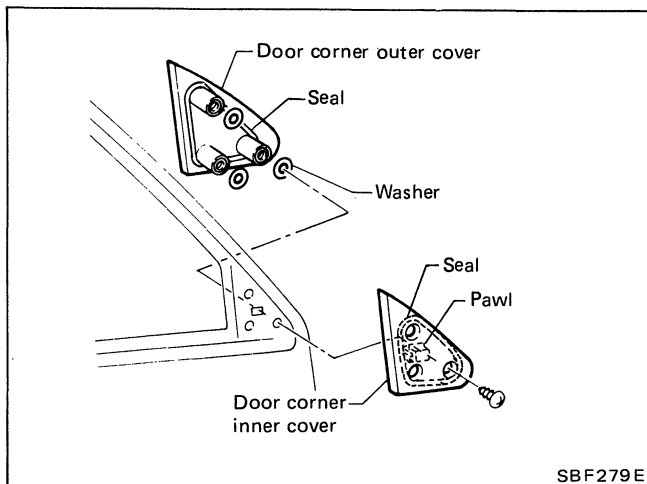

12 Door waist inner seal

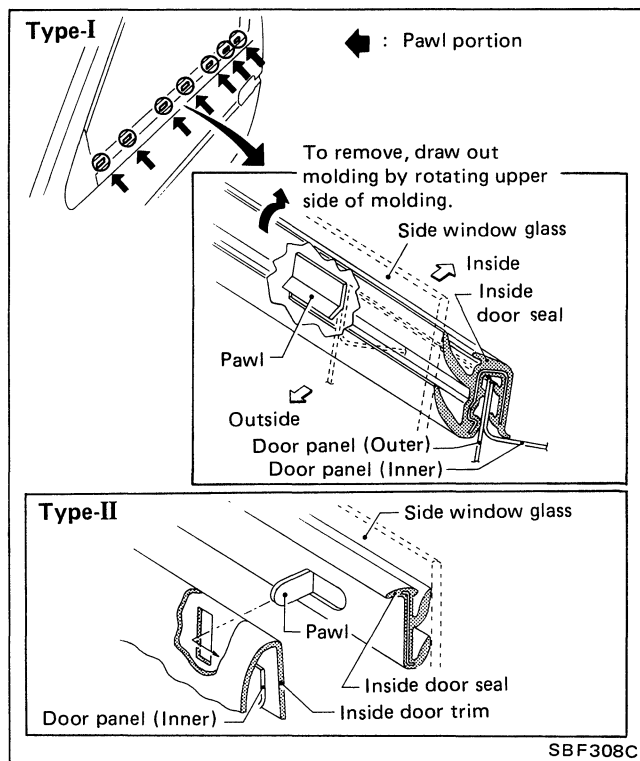

13 Door waist outer seal

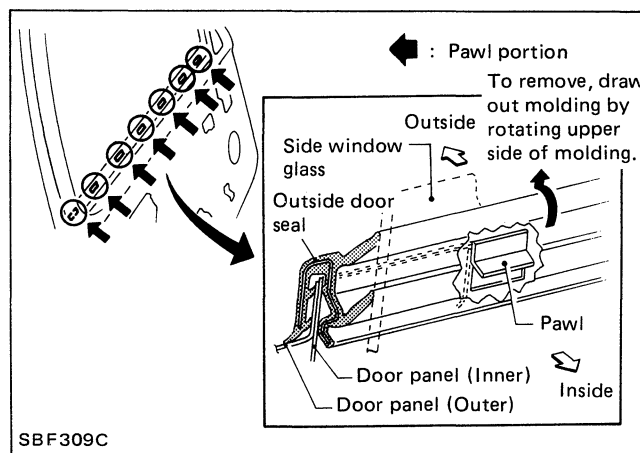

14 Drafter duct

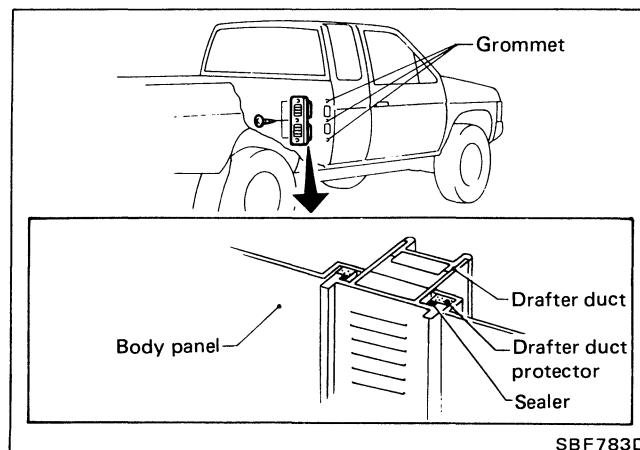

Exterior—TRUCK (Cont'd)

15 Back window

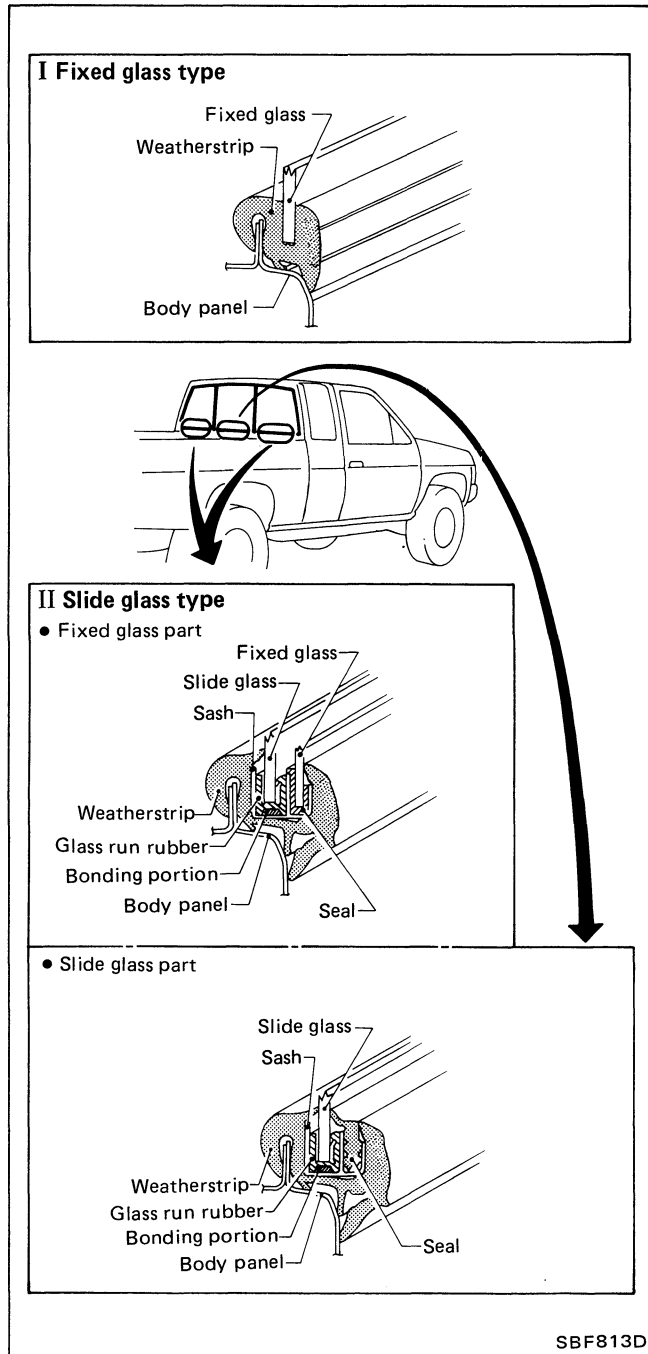

16 17 Rear side window weatherstrip and rear side window protector

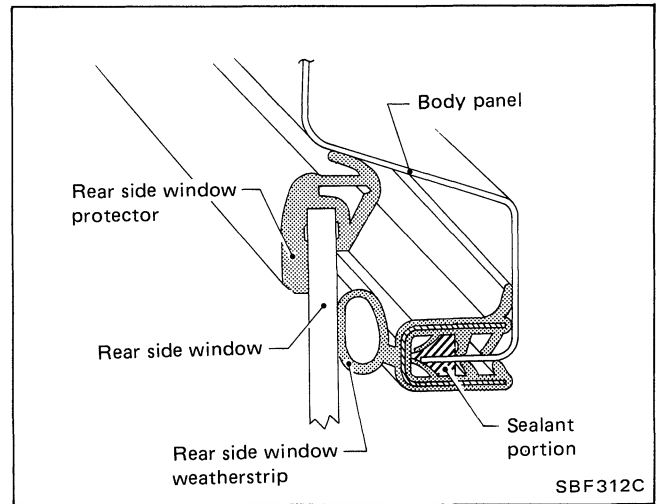

18 19 Sun roof weatherstrip and lid protector

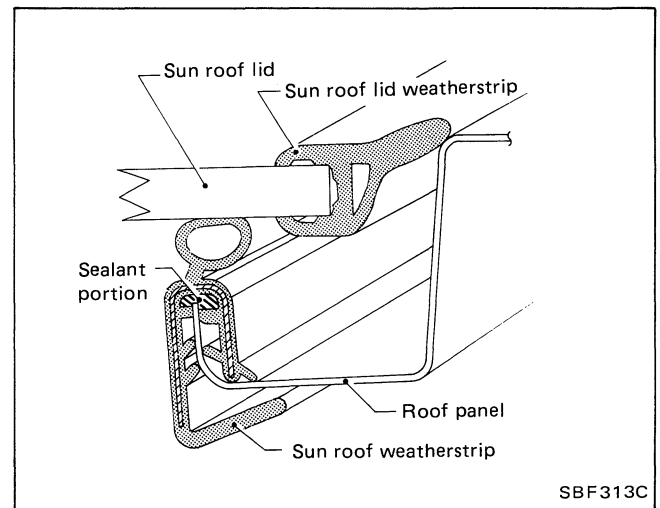

20 Rope hook protector

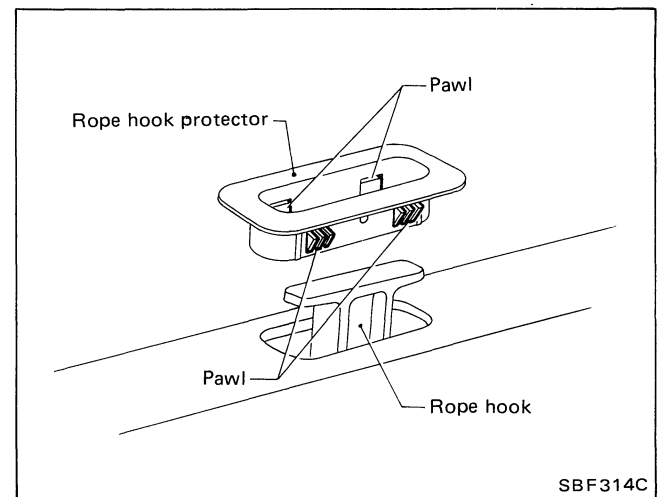

② Rear gate finisher

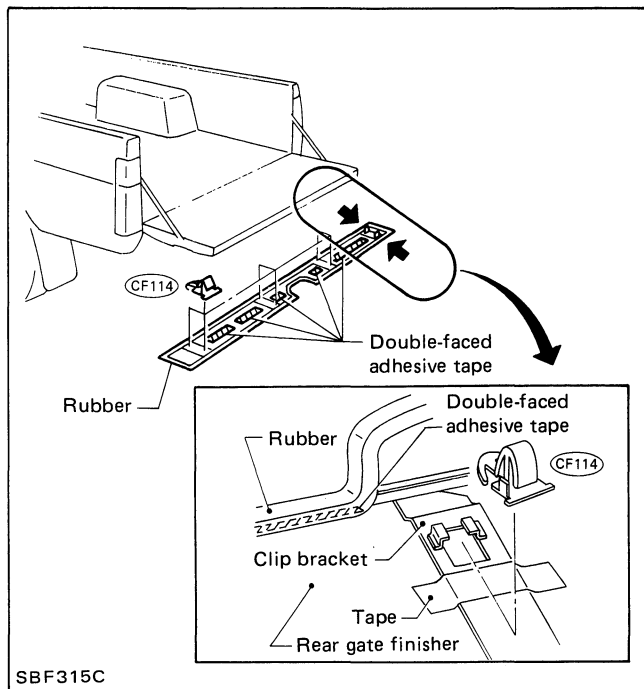

SBF315C

INTERIOR AND EXTERIOR

Exterior—VAN & WAGON

- Apply sealing compound where necessary while installing parts.
- When applying sealing compound, be careful that the sealing compound does not protrude from parts.

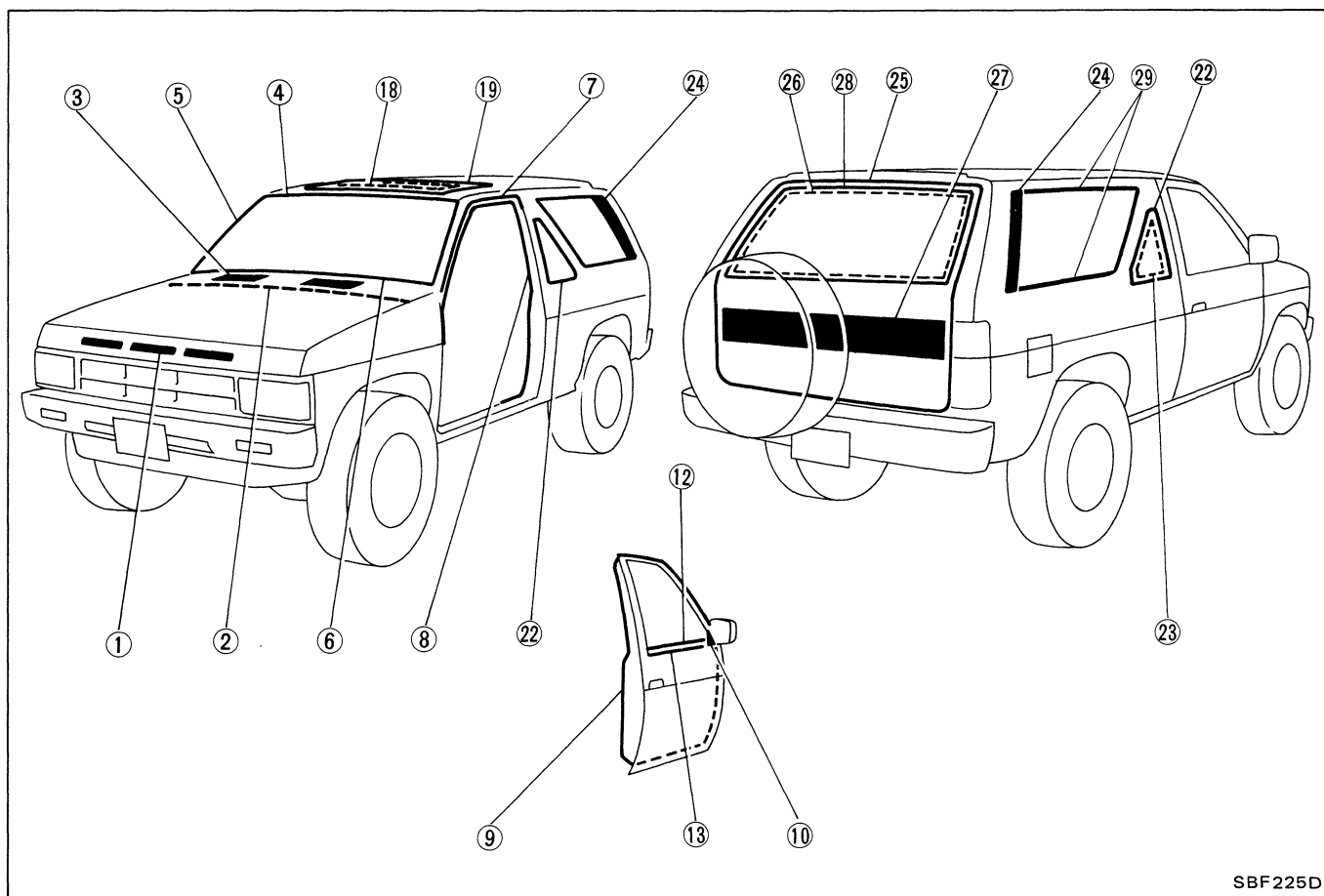

SBF225D

Parts name	Remarks
① Hood top air inlet grille ② ③ Cowl top sealing rubber & grille ④ Windshield upper molding ⑤ ⑥ Windshield side & lower molding ⑦ Drip weatherstrip ⑧ Body side welt & seal ⑨ Door weatherstrip ⑩ Door corner cover ⑫ Door waist inner seal ⑬ Door waist outer seal ⑱ ⑱ Sun roof weatherstrip and lid protector	Basically the same as TRUCK. Refer to the applicable sections on the preceding pages.
⑳ Side window grille ㉑ Side window weatherstrip ㉒ Air outlet grille ㉓ Back door weatherstrip ㉔ Back door window weatherstrip ㉕ Back door finisher	Refer to following description.
㉖ Back door window molding ㉗ 2nd side window molding	Basically the same as ④ windshield upper molding. Refer to the applicable sections on the preceding pages.

INTERIOR AND EXTERIOR

Exterior—VAN & WAGON (Cont'd)

22 Side window grille

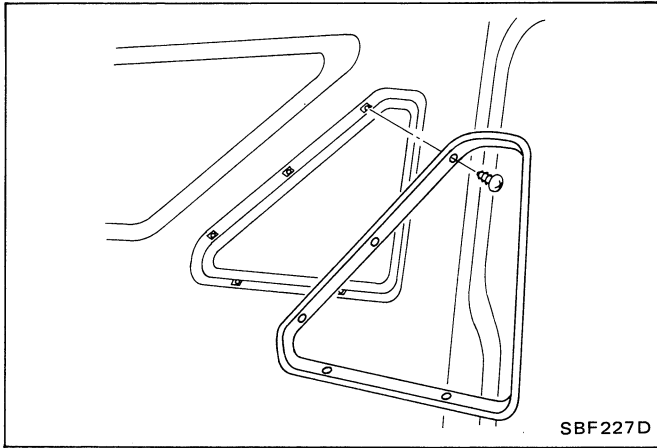

25 Back door weatherstrip

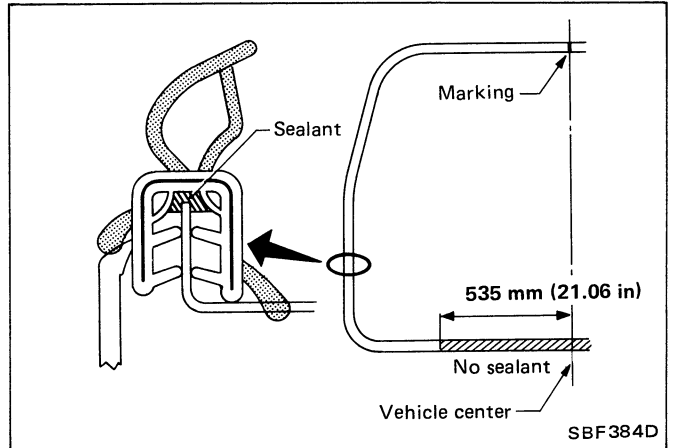

23 Side window weatherstrip

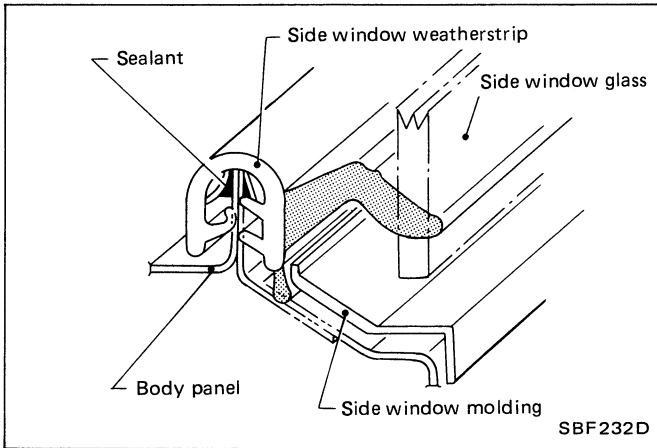

26 Back door window weatherstrip

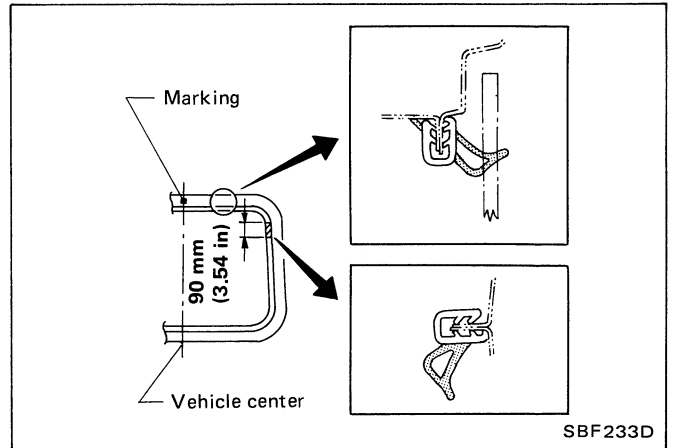

24 Air outlet grille

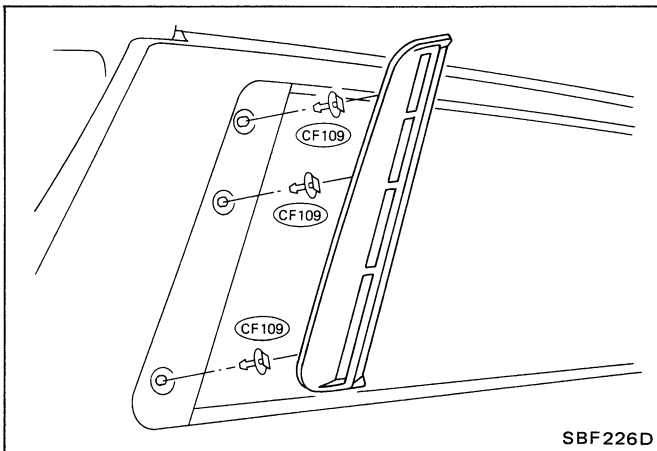

27 Back door finisher

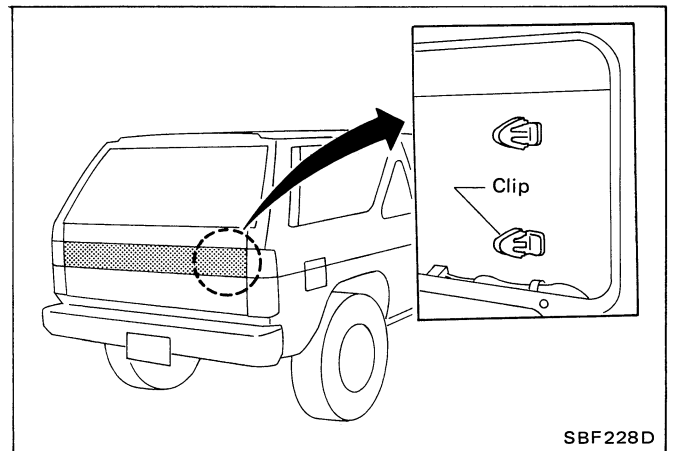

INSTRUMENT

- These parts are made of plastic, so do not use excessive force and be careful not to damage it.
- When removing instrument assembly, remove front pillar garnish.

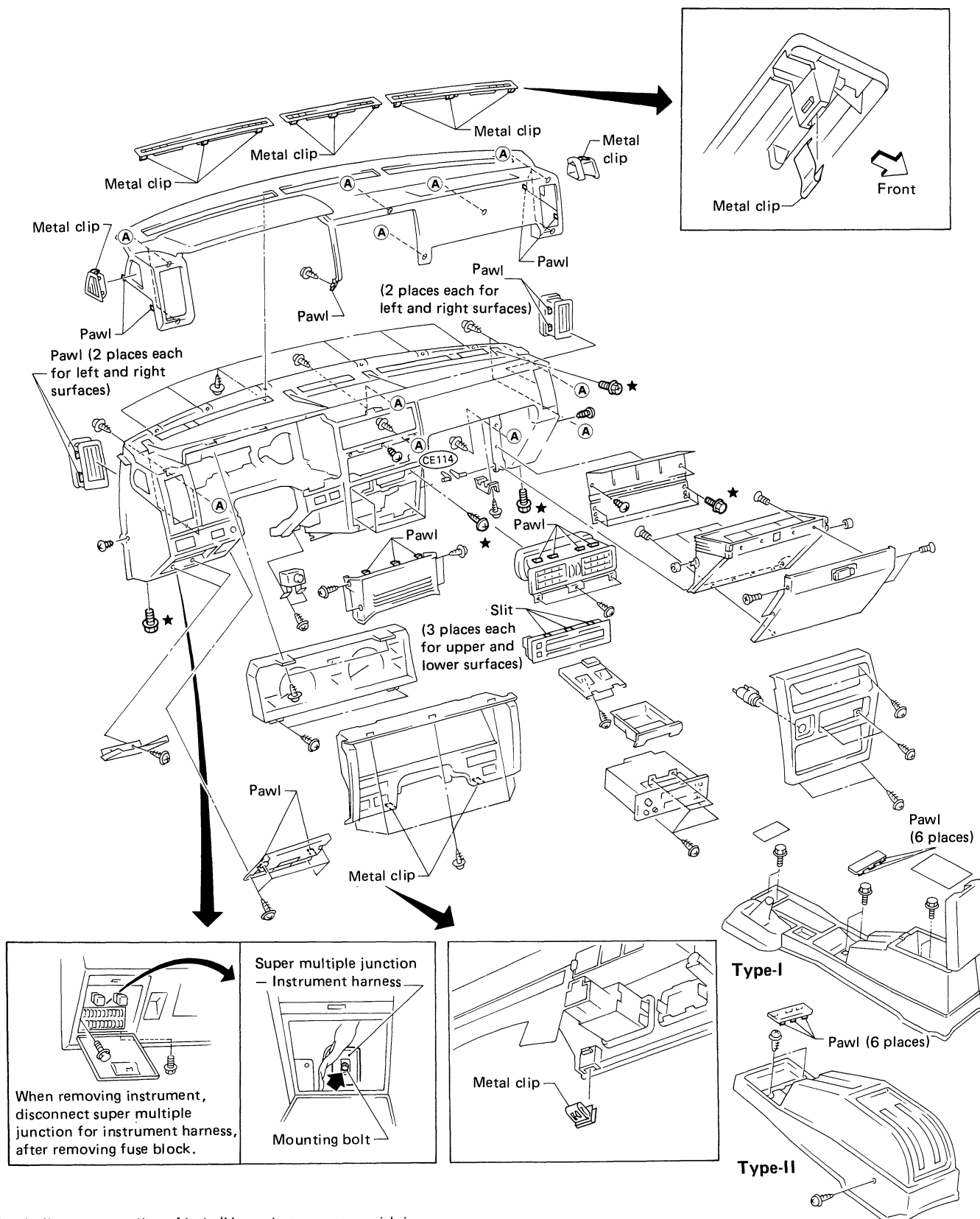

Ⓐ : Indicates center line of bolt (Upper instrument garnish is secured by screws from behind instrument panel.)

★ : Instrument assembly mounting screw

SBF814D

SEAT

- When removing or installing the seat trim, carefully handle it to keep dirt out and avoid damage.

Front Seat

SEPARATE SEAT

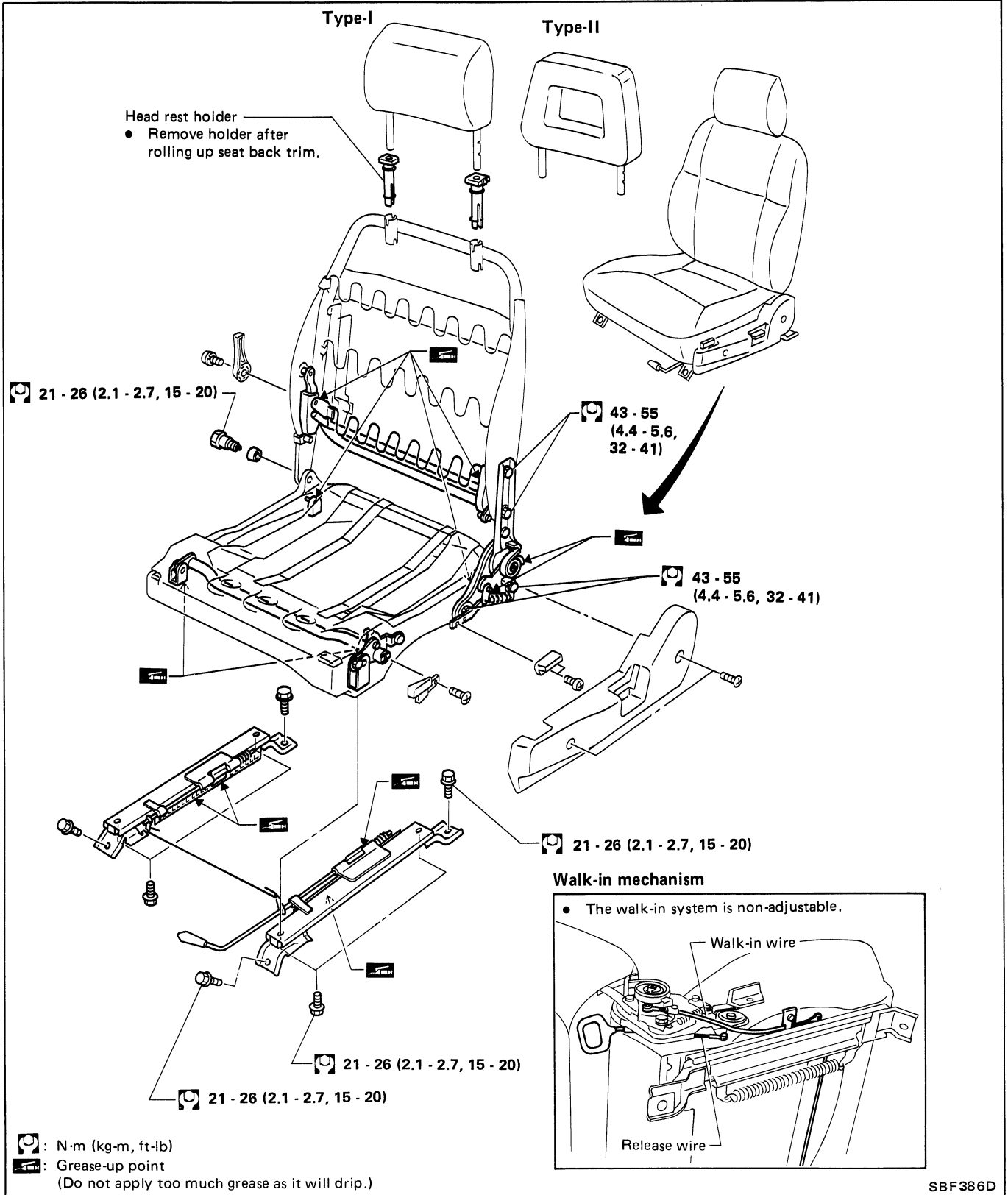

SBF386D

SEAT

Front Seat (Cont'd)

BENCH SEAT – TRUCK

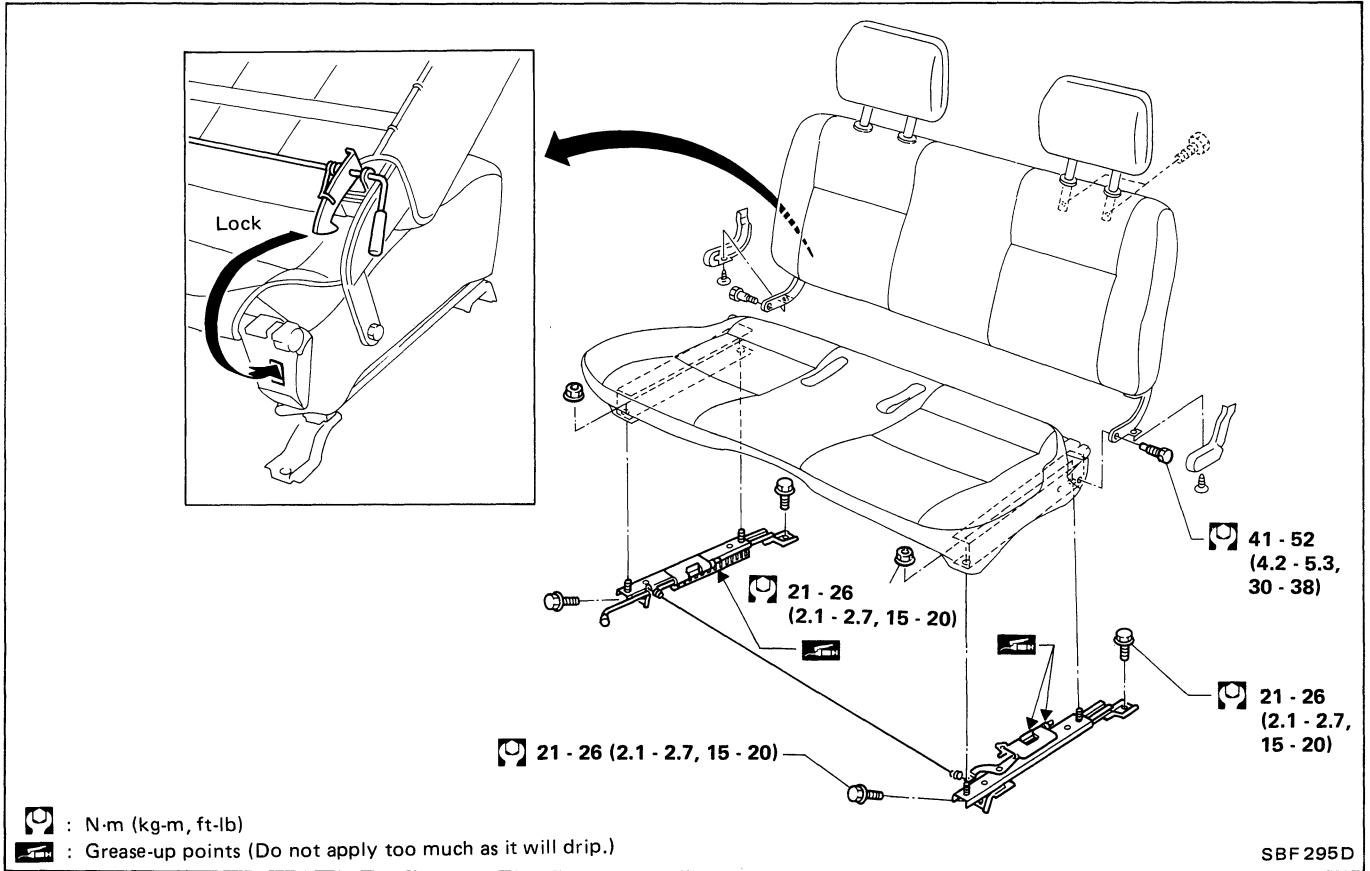

Jump Seat—King Cab Model

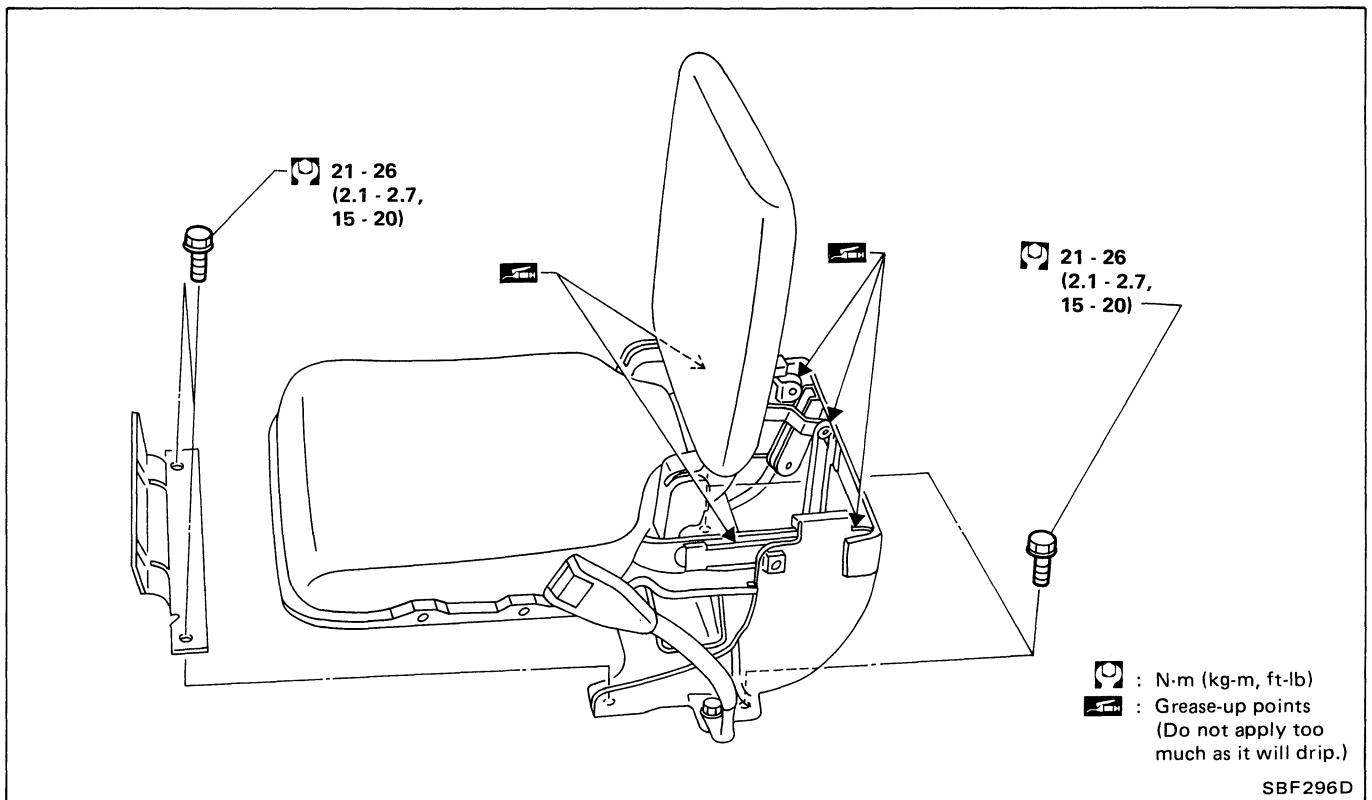

WINDSHIELD AND WINDOWS

Windshield and Back Door Window

REMOVAL

After removing moldings, remove glass.

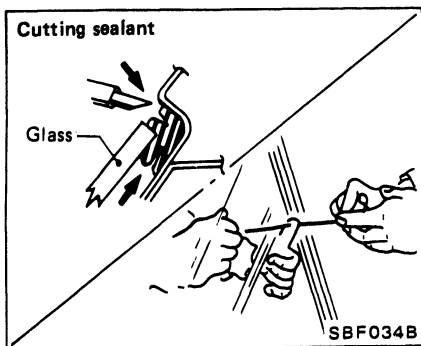

CAUTION:

Be careful not to scratch glass during removal.

INSTALLATION

- Use genuine Nissan Sealant kit or equivalent. Follow instructions furnished with it.
- After installation, the vehicle should remain stationary for about 24 hours.
- Do not use sealant which is more than 12 months past its production date.
- Do not leave cartridge unattended with its cap open.
- Keep primers and sealant in a cool, dry place. Nissan recommends that they are stored in a refrigerator.
- Be sure to install moldings.

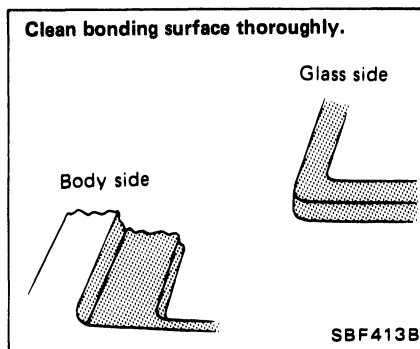

WARNING:

Keep heat or open flames away as primers are flammable.

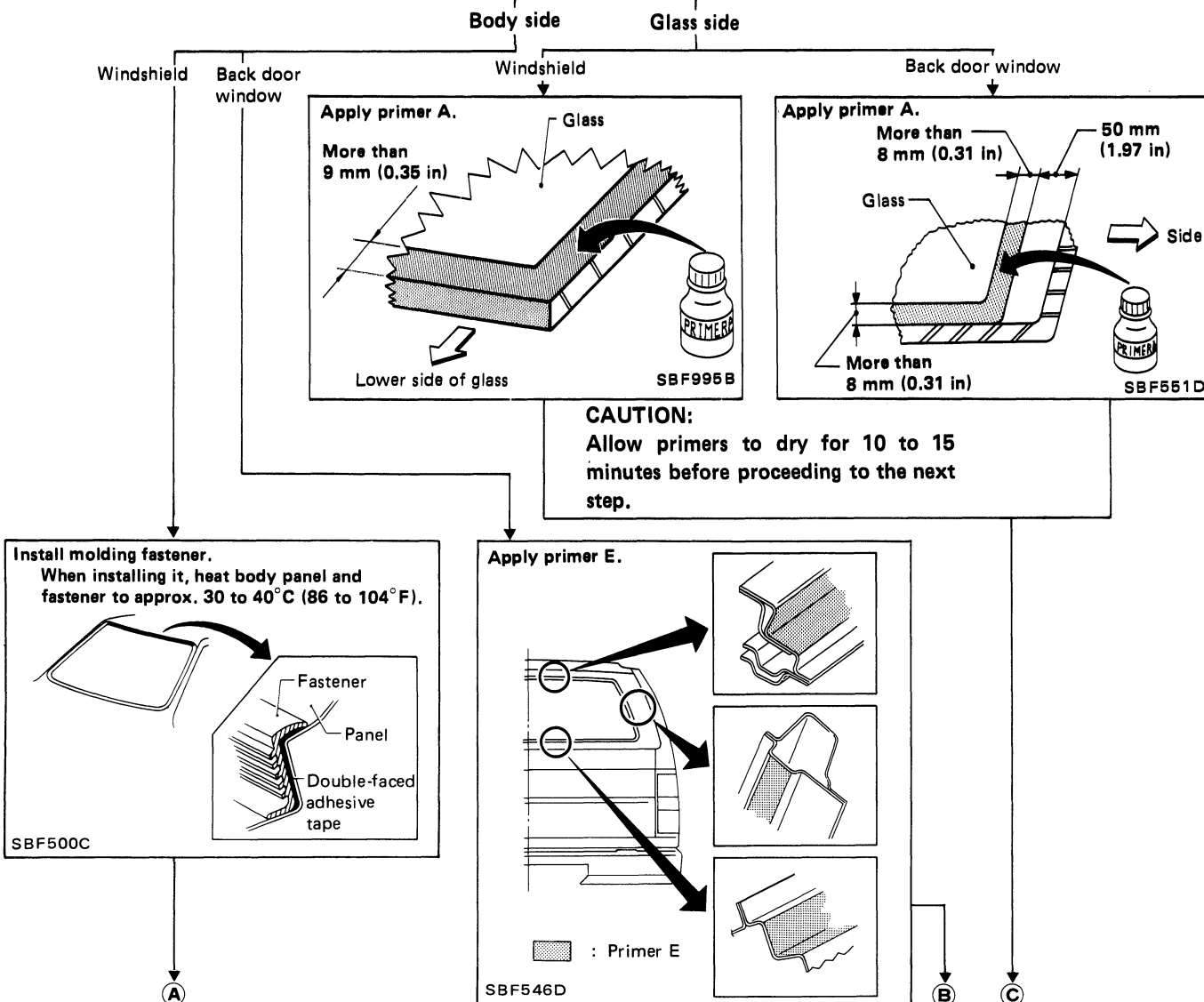

WINDSHIELD AND WINDOWS

Windshield and Back Door Window (Cont'd)

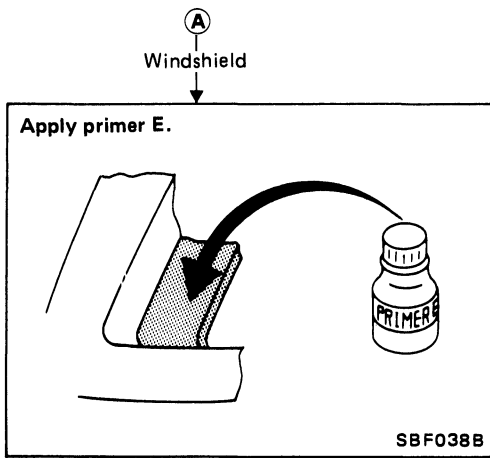

CAUTION:
Allow primers to dry for 10 to 15 minutes before proceeding to the next step.

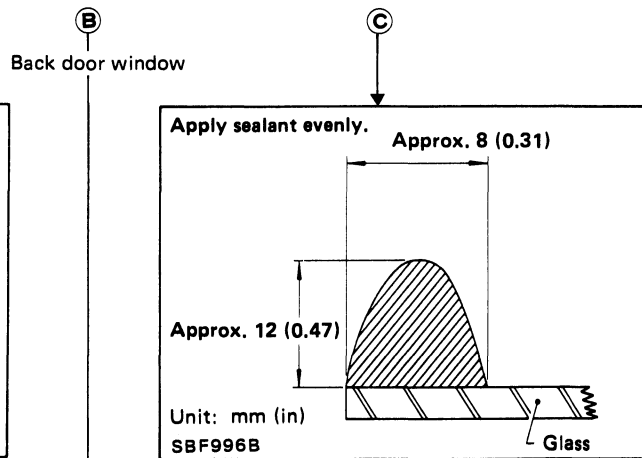

CAUTION:
Windshield glass should be installed within 15 minutes of applying sealant: sealant starts to harden 15 minutes after it is applied.

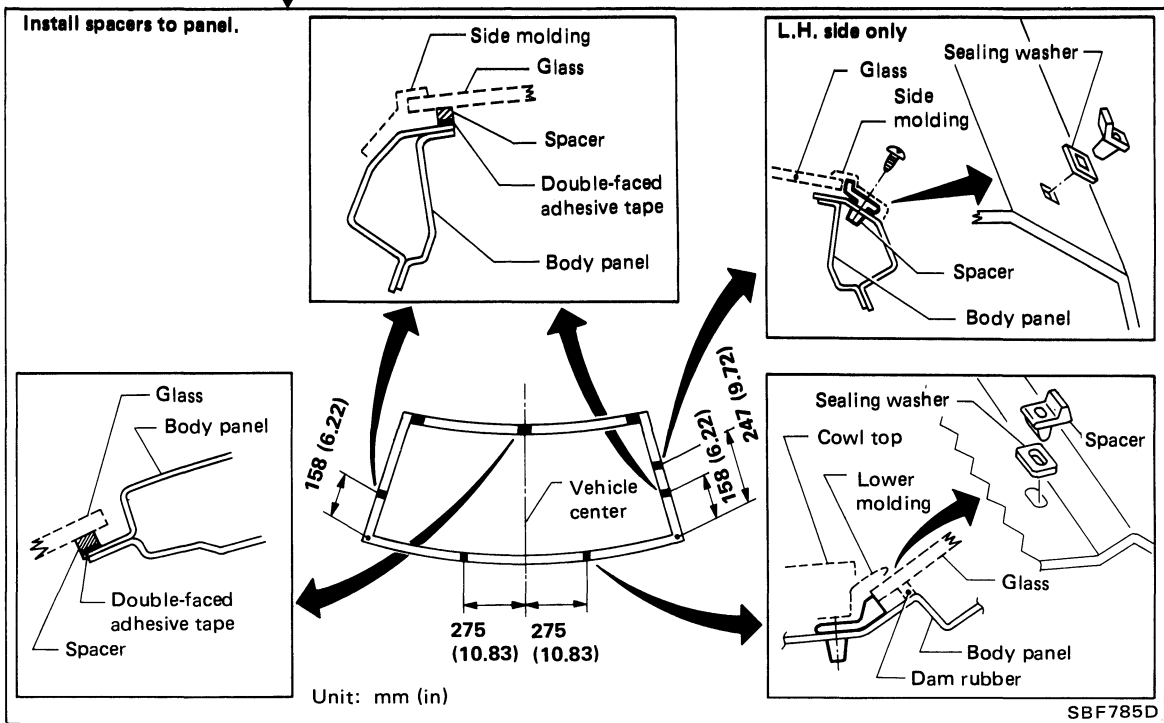
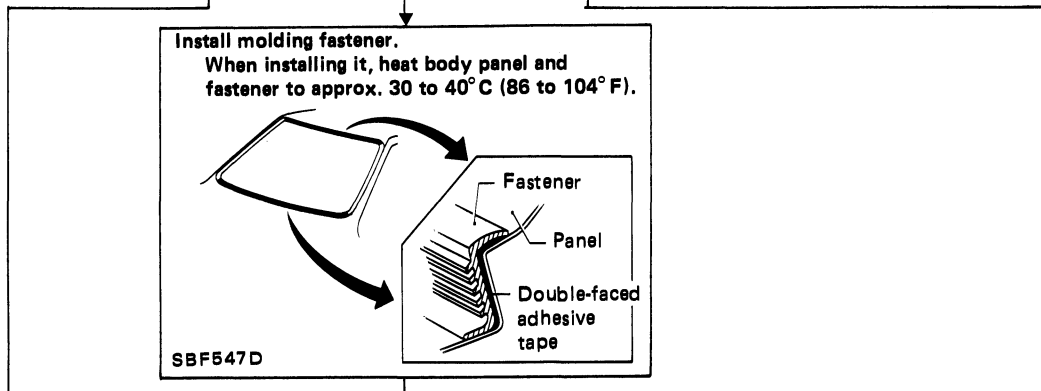

D

E

F

WINDSHIELD AND WINDOWS

Windshield and Back Door Window (Cont'd)

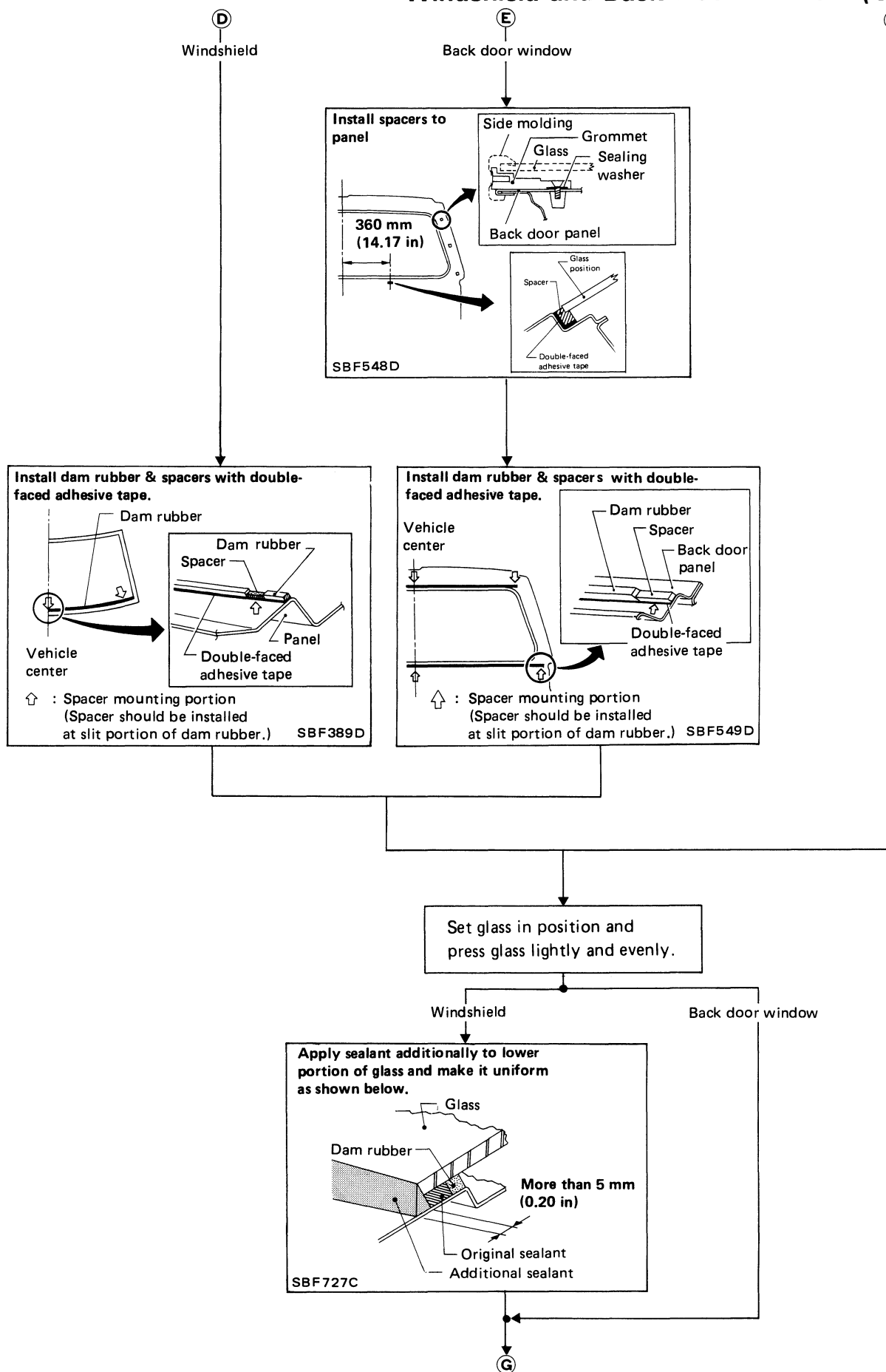

WINDSHIELD AND WINDOWS

Windshield and Back Door Window (Cont'd)

Ⓒ

Check for water leakage.

Back door window

Windshield

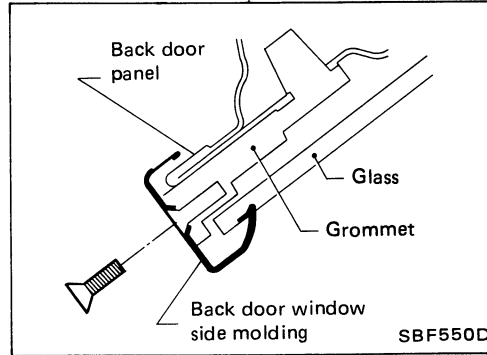
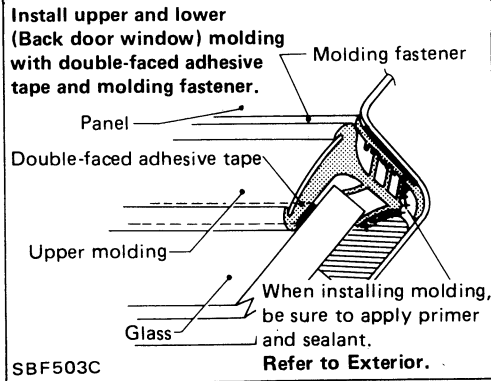

Install side and lower moldings.

Refer to Exterior.

CAUTION:
Molding must be installed securely so that it is in position and leaves no gap.

WINDSHIELD AND WINDOWS

Windshield and Back Door Window (Cont'd)

DRYING TIME OF SEALANT

Chart below shows time required for sealant to dry desired hardness.

CAUTION:

Advise the user of the fact that vehicle should not be driven on rough roads or surfaces until sealant has properly vulcanized.

Unit: Days

Temperature °C (°F)	Relative humidity %		
	90	50	25
25 (77)	1.2	2.2	4.0
5 (41)	2.6	7.0	11.9

REPAIRING WATER LEAKS

Leaks can be repaired without removing and reinstalling glass.

If water is leaking between caulking material and body or between glass and caulking material, determine the extent of the leak by applying water while pushing glass outward.

To stop the leak, apply primer and then sealant to the leak point.

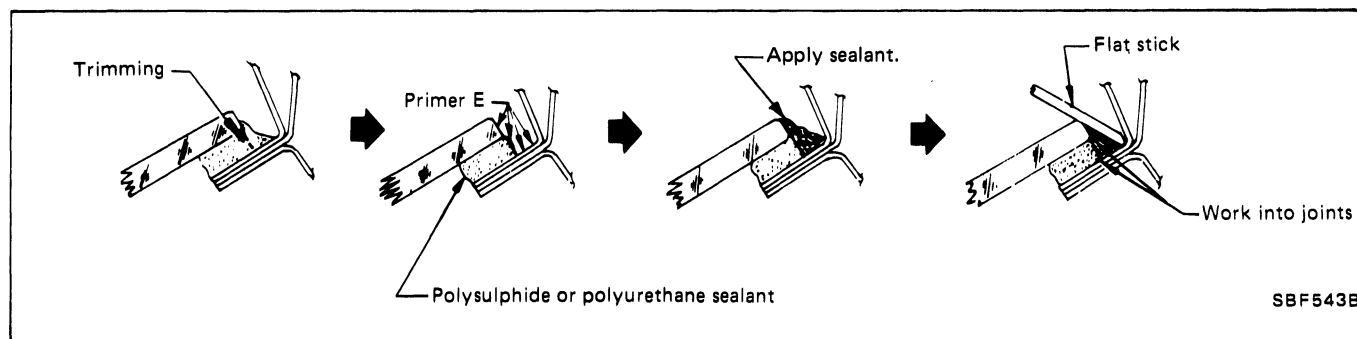

Back Window—TRUCK

- Window glass is held in place by weatherstripping. For details regarding weatherstrip, refer to "Exterior".
- Apply sealant to clearances between vehicle body panel and weatherstrip as necessary.

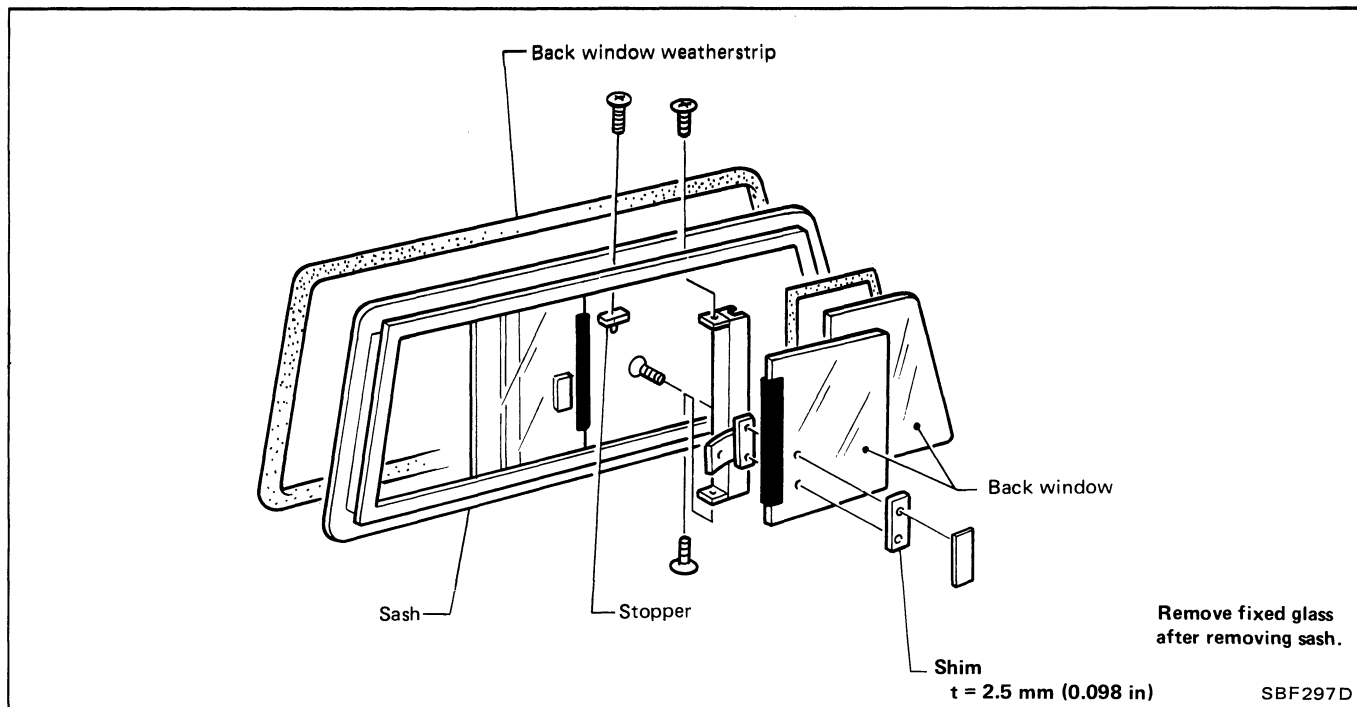

WINDSHIELD AND WINDOWS

Rear Side Window—TRUCK

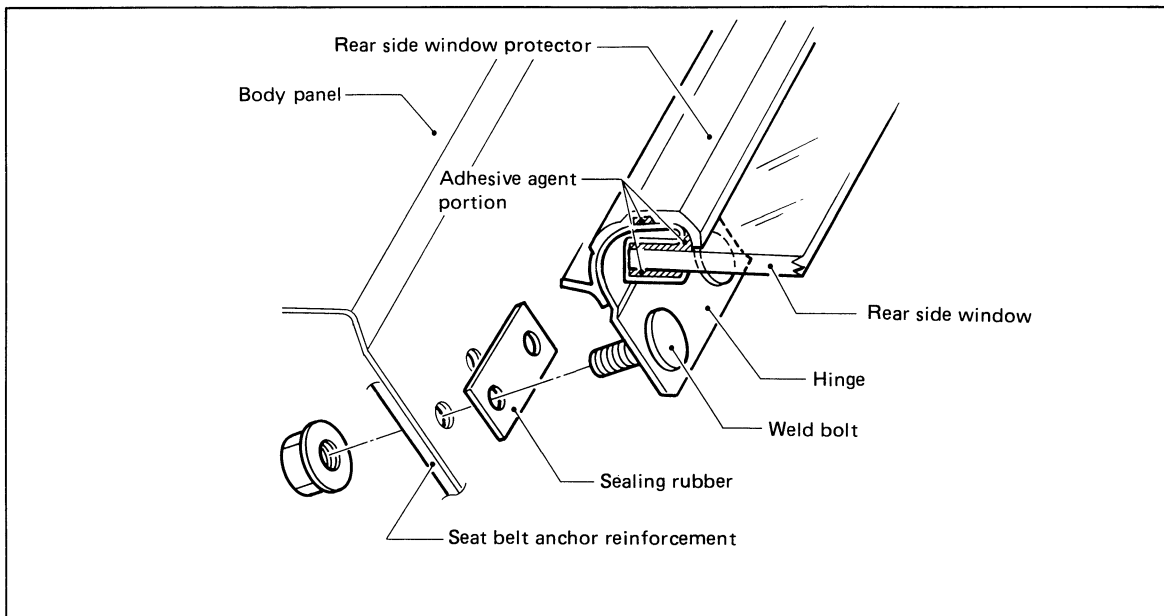
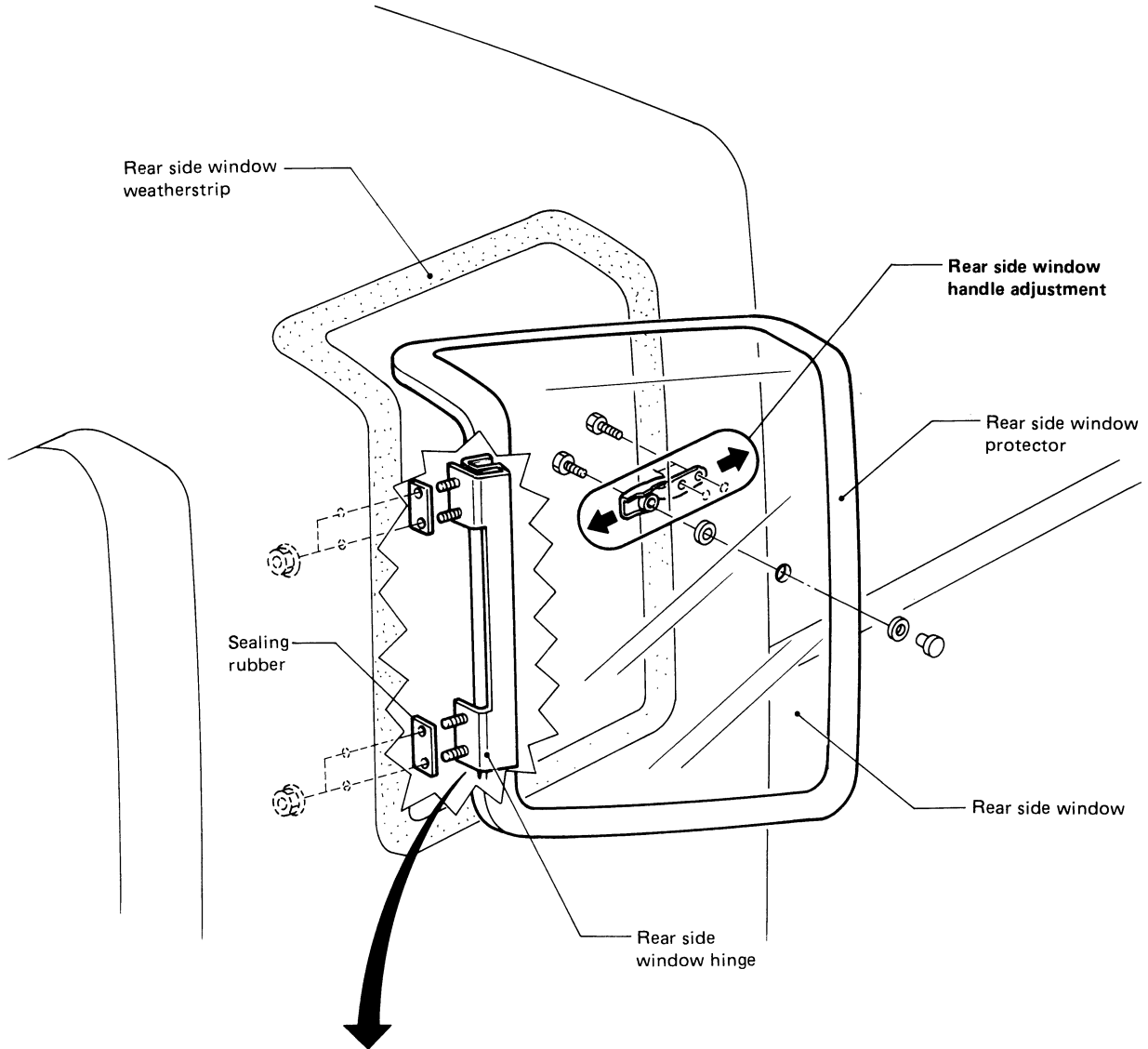

SBF523C

WINDSHIELD AND WINDOWS

Rear Side Window—VAN & WAGON

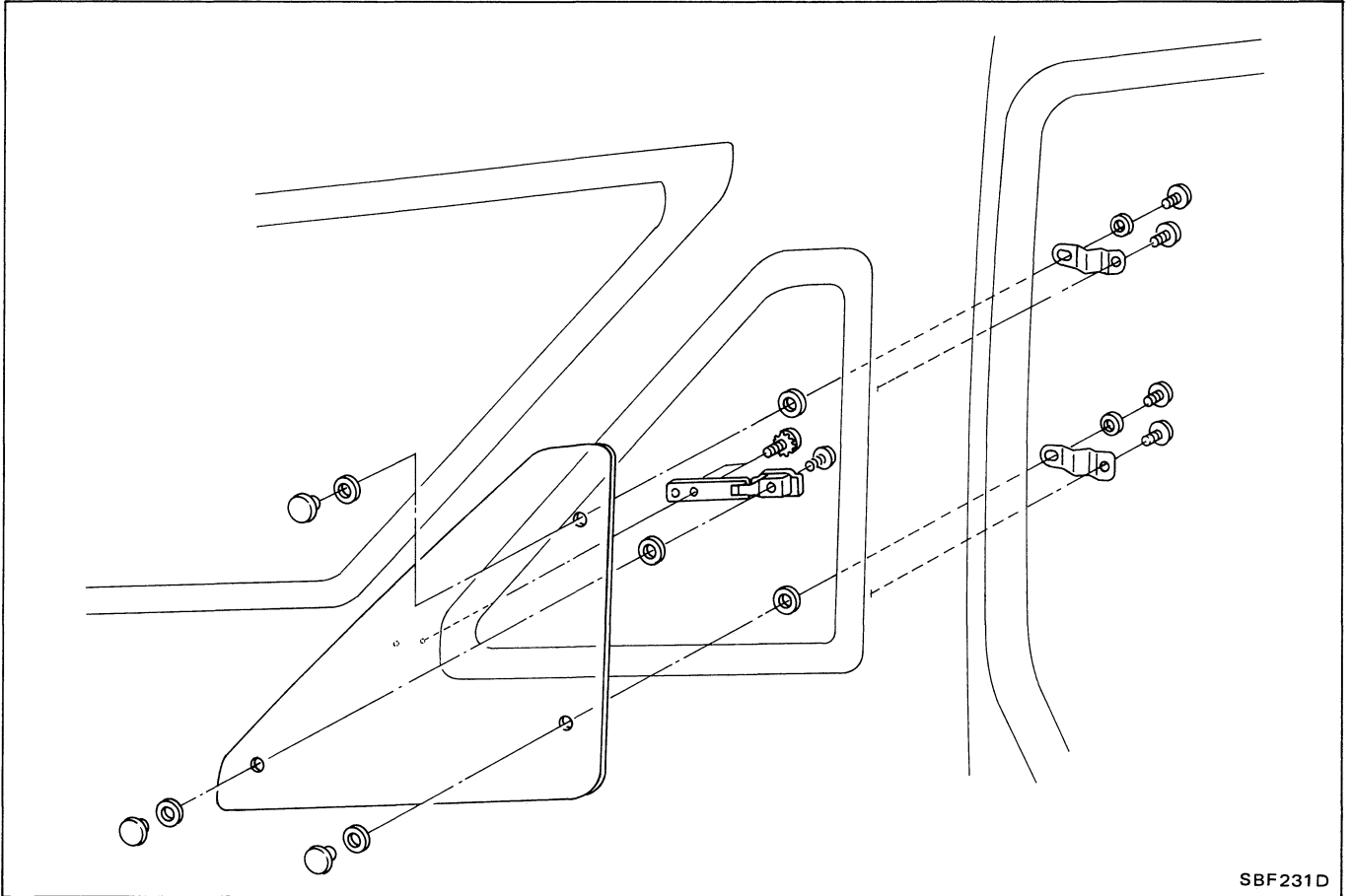

WINDSHIELD AND WINDOWS

Rear Side Window (2nd)—VAN & WAGON

- The drying period for sealant is the same as that of windshield and back door window. Refer to "DRYING TIME OF SEALANT".

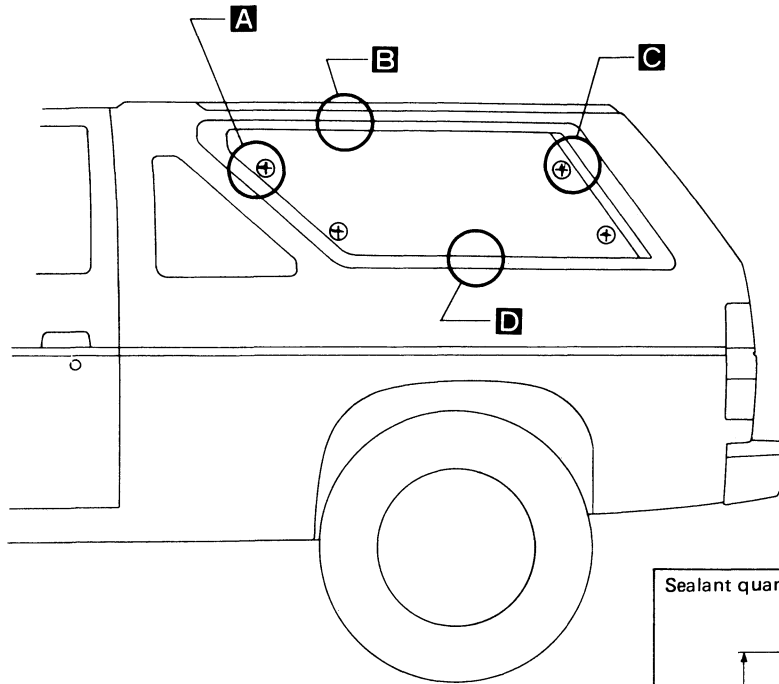

⊕ : BOLT

Unit: mm (in)

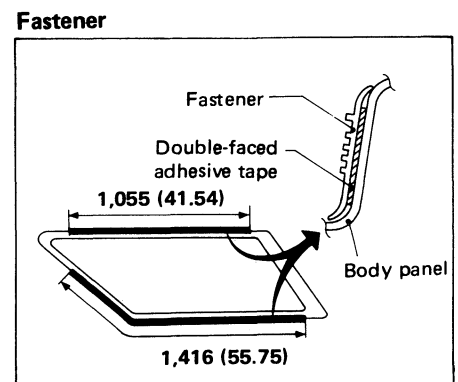
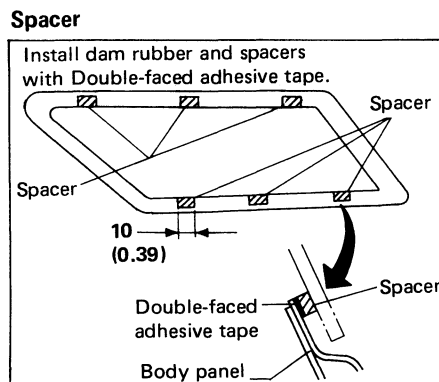
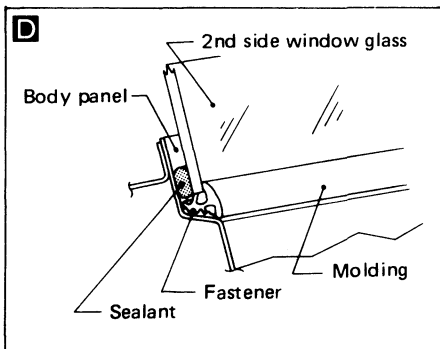
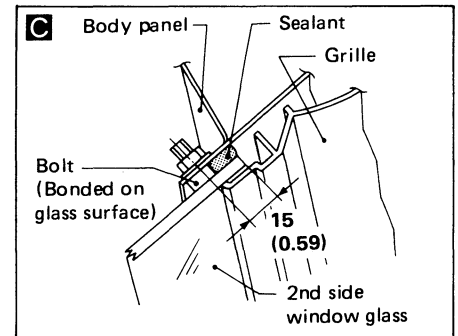
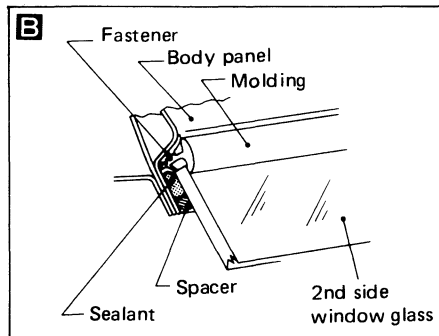
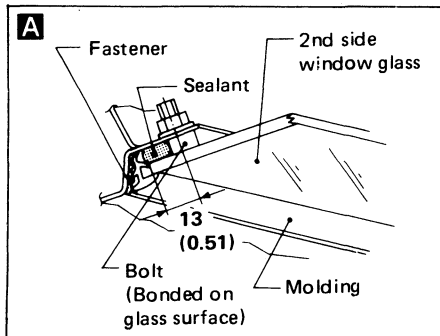
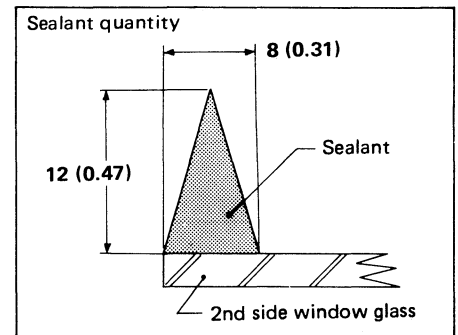

SBF786D

SUN ROOF

Service Procedure

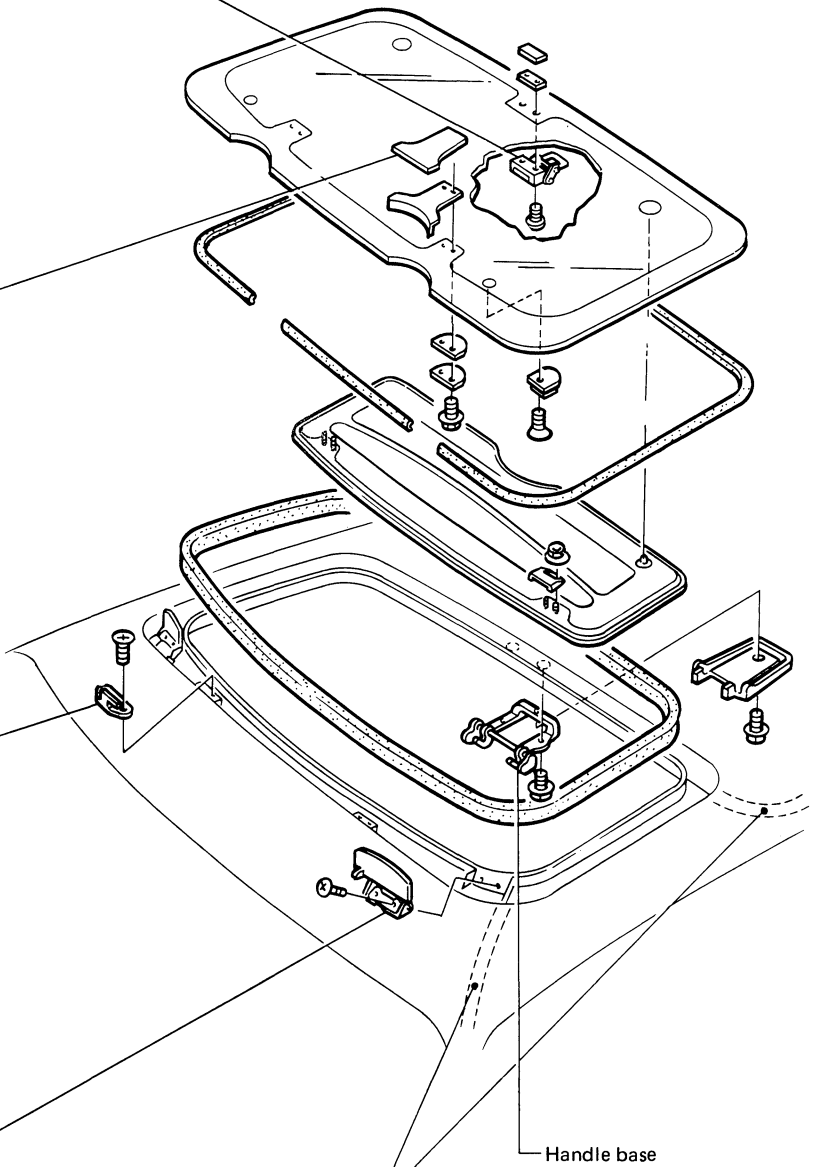
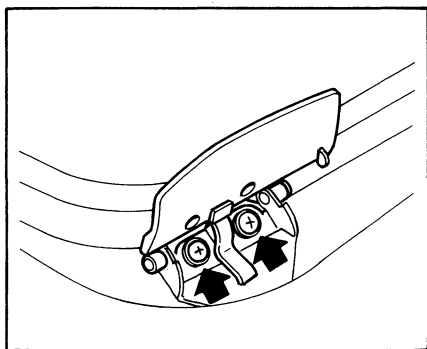
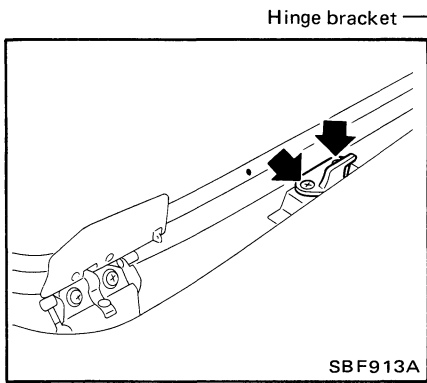
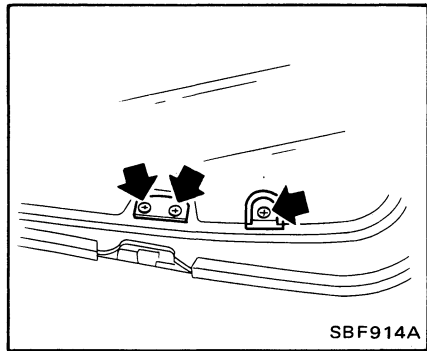
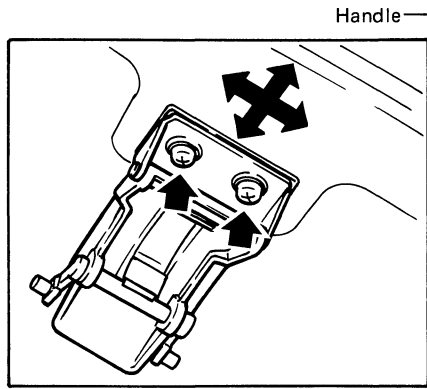

Drain hose
After installation of drain hoses, make sure water drains smoothly.

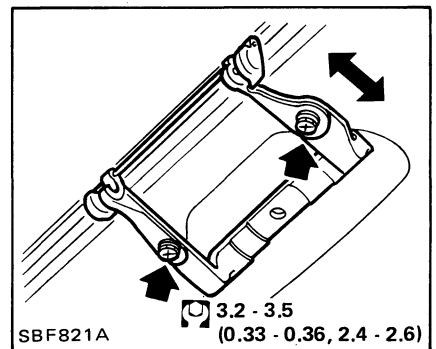

: N·m (kg·m, ft·lb)

SBF282E

MIRROR

Door Mirror

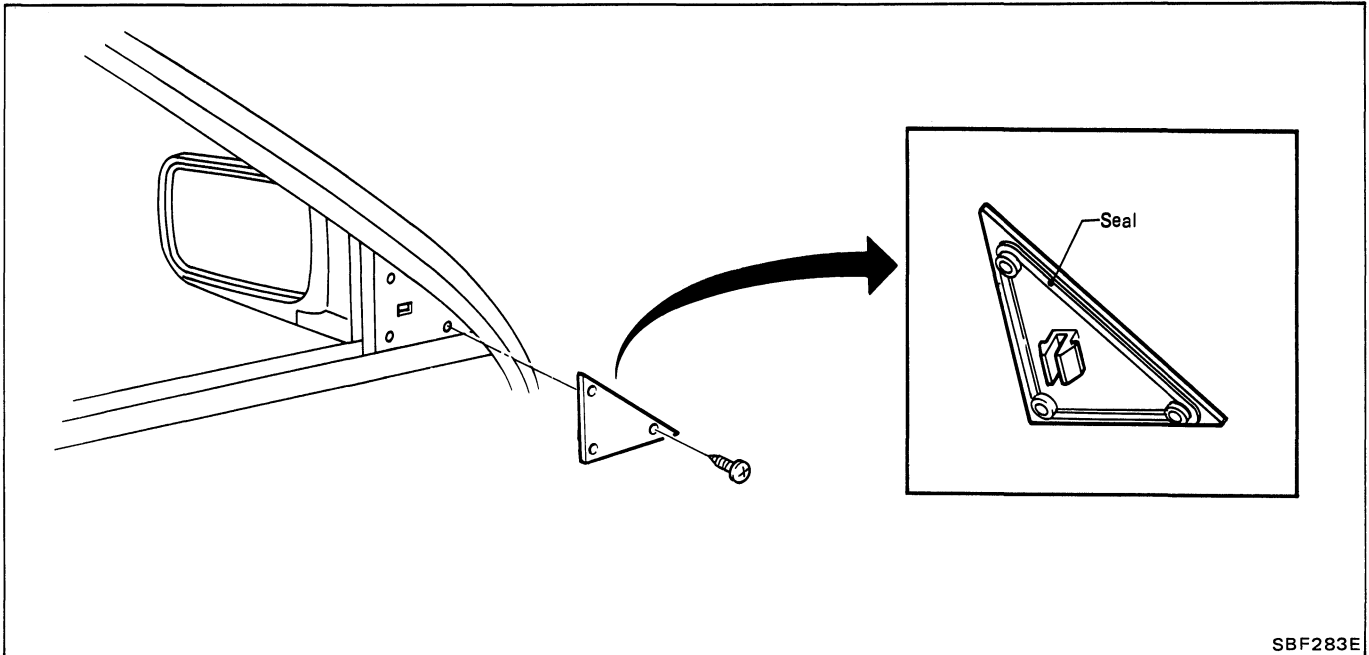

SBF283E

ELECTRICAL REMOTE CONTROL DOOR MIRROR WIRING DIAGRAM

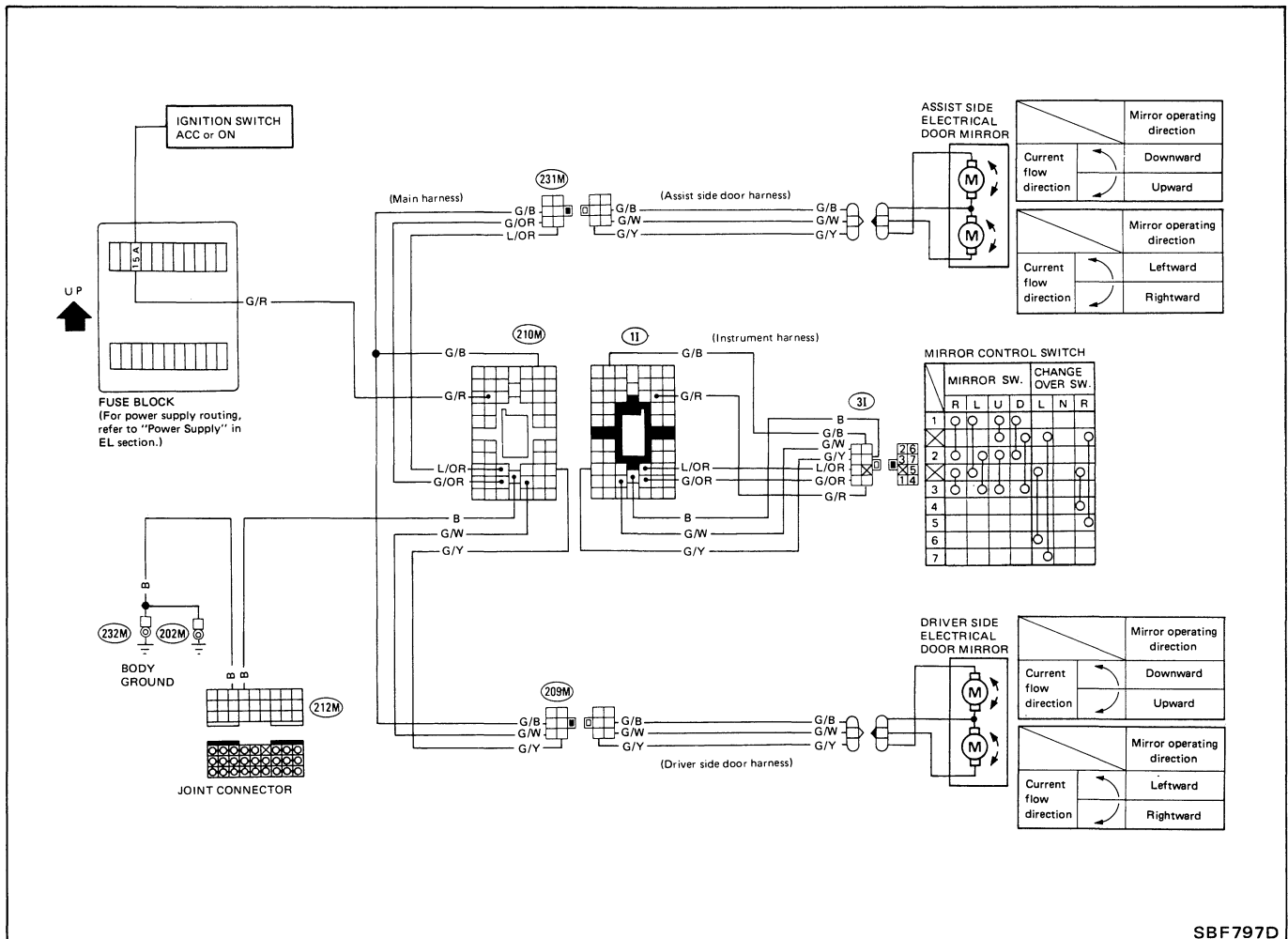

SBF797D

CAB AND REAR BODY

Cab Body—TRUCK

- Remove following parts in engine room at least.
 - (1) Main harness and other wiring harness
- Disconnect brake and clutch line in engine compartment.
- Remove following parts under body at least.
 - (1) Transmission and transfer control levers
 - (2) Hand brake control lever and cable
 - (3) Main harness and other wiring harness

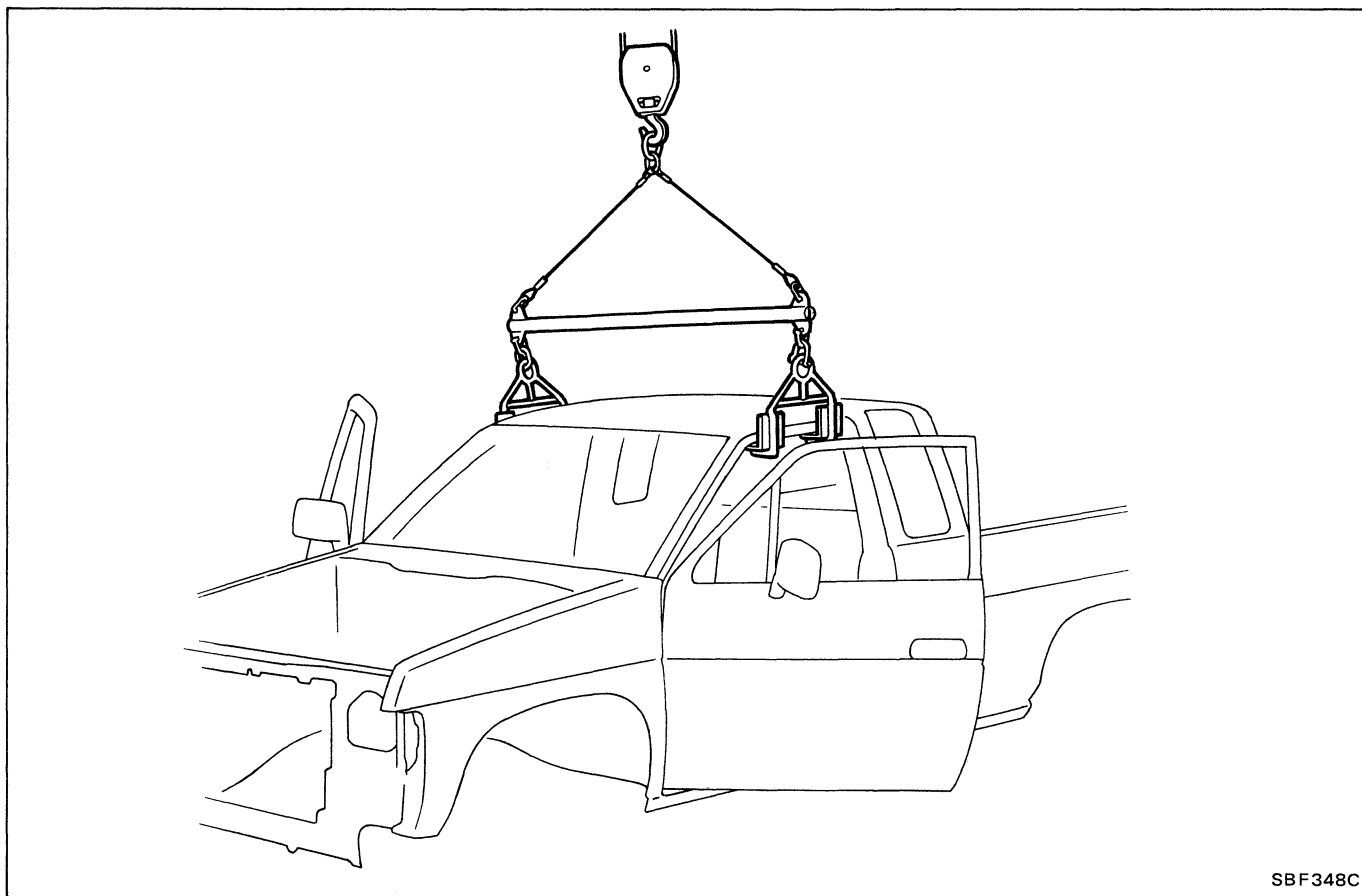

SBF348C

CAB AND REAR BODY

Rear Body—TRUCK

- Remove following parts at least.
 - (1) Rear combination lamp and license plate lamp harness.
 - (2) Fuel filler tube fixing screws.

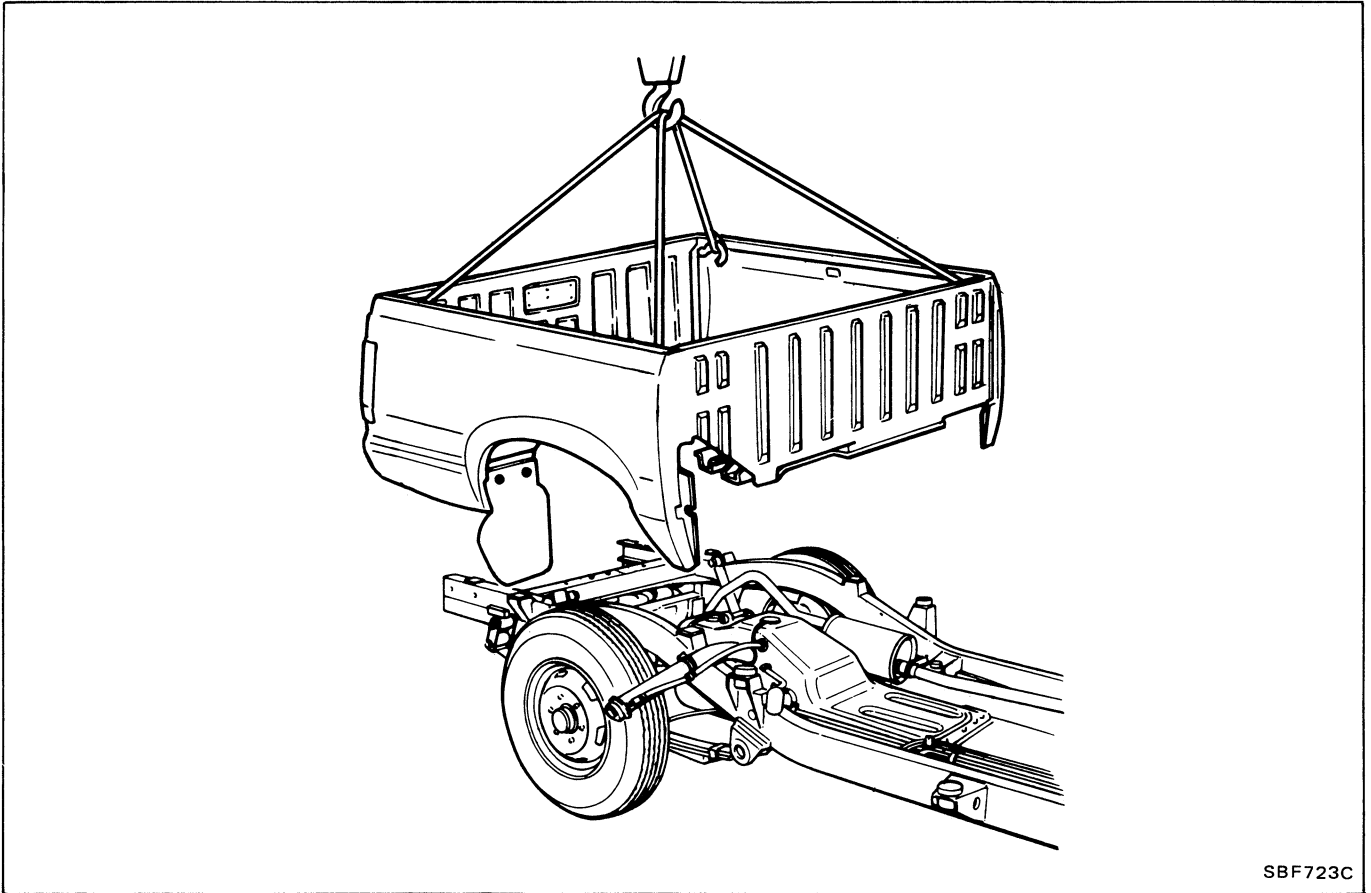

SBF723C

CAB AND REAR BODY

Cab Body—VAN & WAGON

- Remove following parts in engine room at least.
 - (1) Main harness and other wiring harness
- Disconnect brake and clutch line in engine compartment.
- Remove following parts under body at least.
 - (1) Transmission and transfer control levers
 - (2) Hand brake control lever and cable
 - (3) Main harness and other wiring harness
- Remove seat belt anchor bolt.

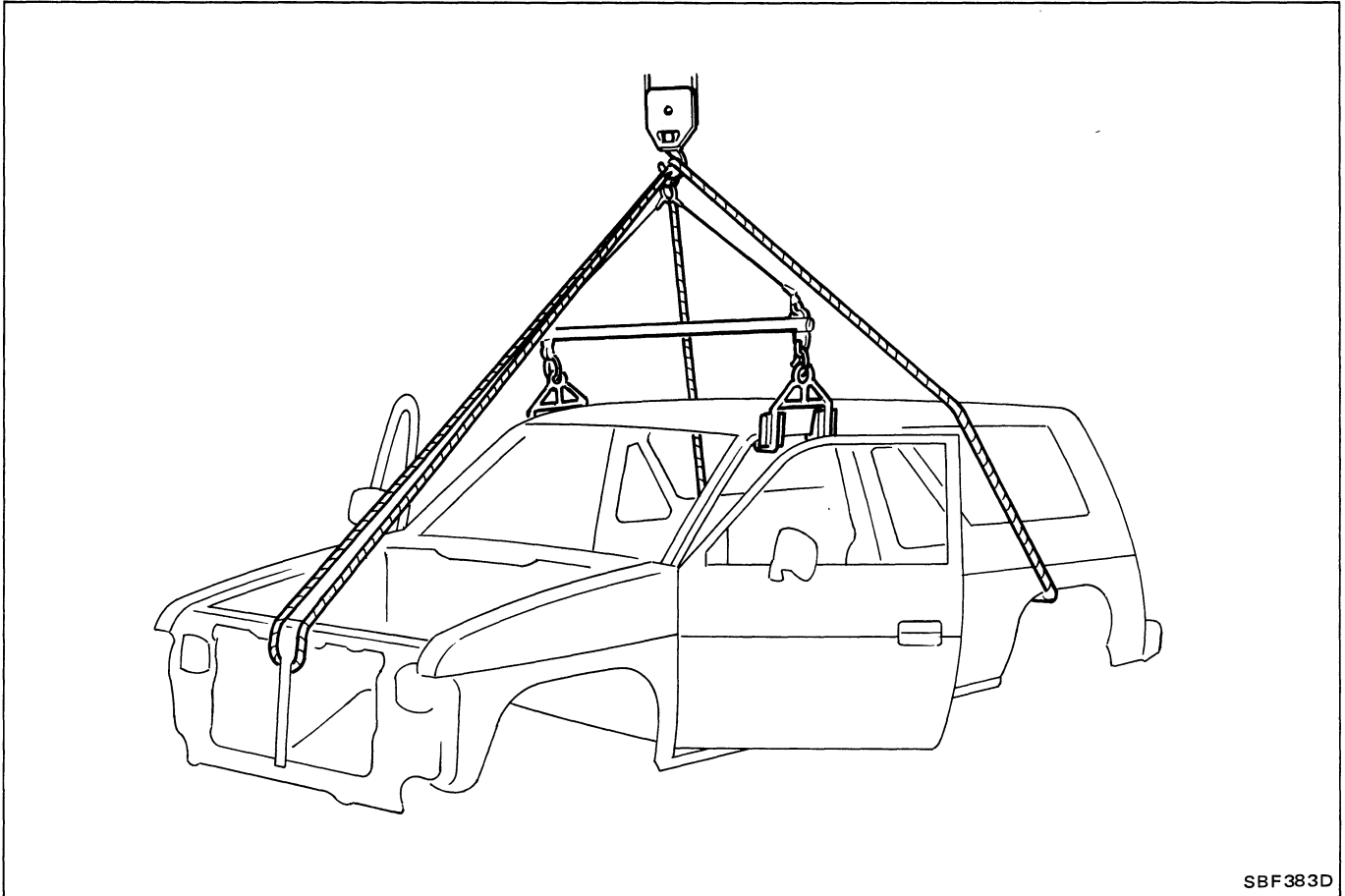

SBF383D

CAB AND REAR BODY

Body Mounting—TRUCK

When removing, be sure to replace bolts and nuts (sealant applied bolts or self-lock nuts are used for all mounting).

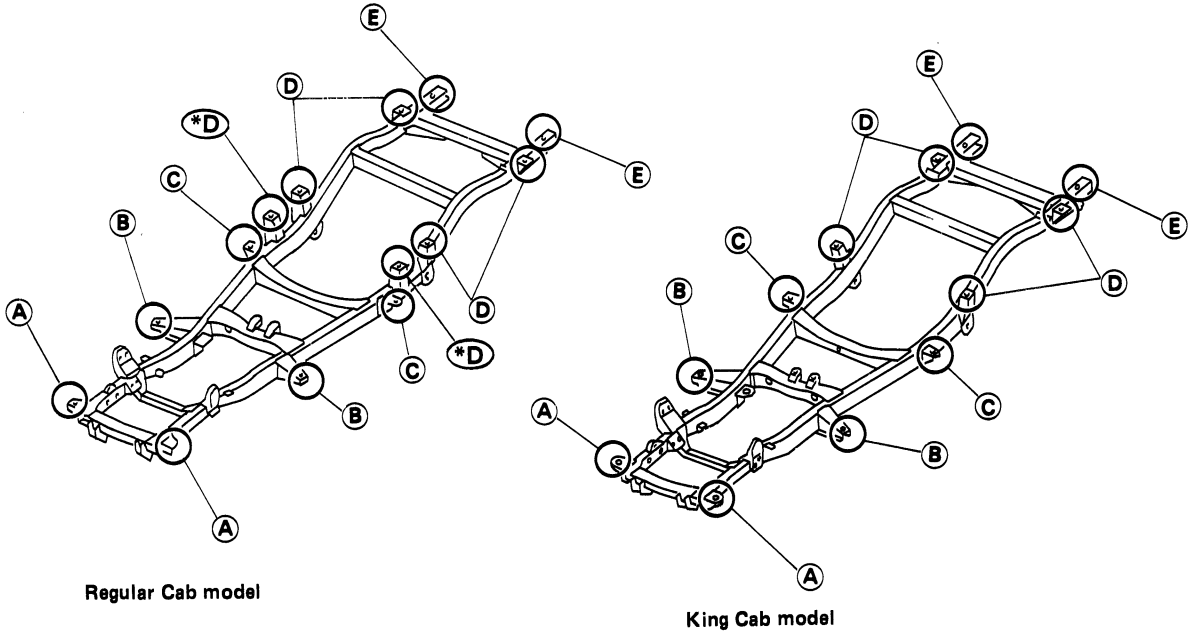

(*D) : Except for short wheelbase model (This bracket is not used for body mounting.)

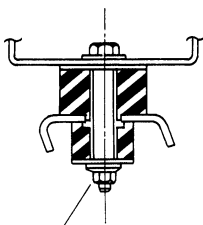

19 - 25
(1.9 - 2.6,
14 - 19)

Section **(A)**

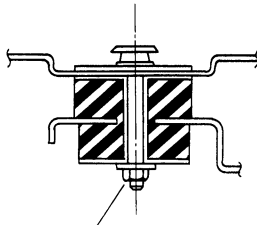

31 - 42
(3.2 - 4.3,
23 - 31)

Section **(B)**

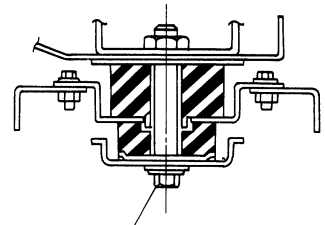

31 - 42
(3.2 - 4.3,
23 - 31)

Section **(C)**

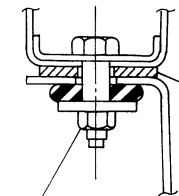

Shim
[t = 4.5 mm
(0.177 in)]

20 - 24
(2.0 - 2.4,
14 - 17)

Section **(D)**

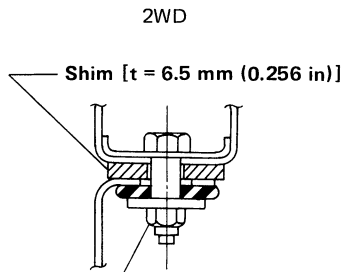

Shim [t = 6.5 mm (0.256 in)]

20 - 24
(2.0 - 2.4,
14 - 17)

Section **(E)**

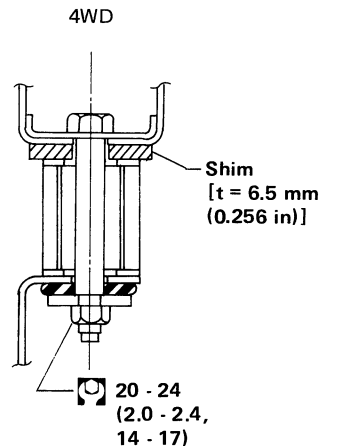

4WD

Shim
[t = 6.5 mm
(0.256 in)]

20 - 24
(2.0 - 2.4,
14 - 17)

: N·m (kg·m, ft·lb)
SBF350C

CAB AND REAR BODY

Body Mounting—VAN & WAGON

When removing, be sure to replace bolts and nuts (sealant applied bolts or self-lock nuts are used for all mounting).

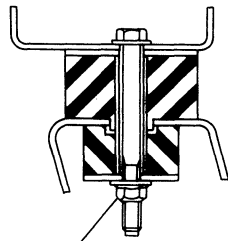
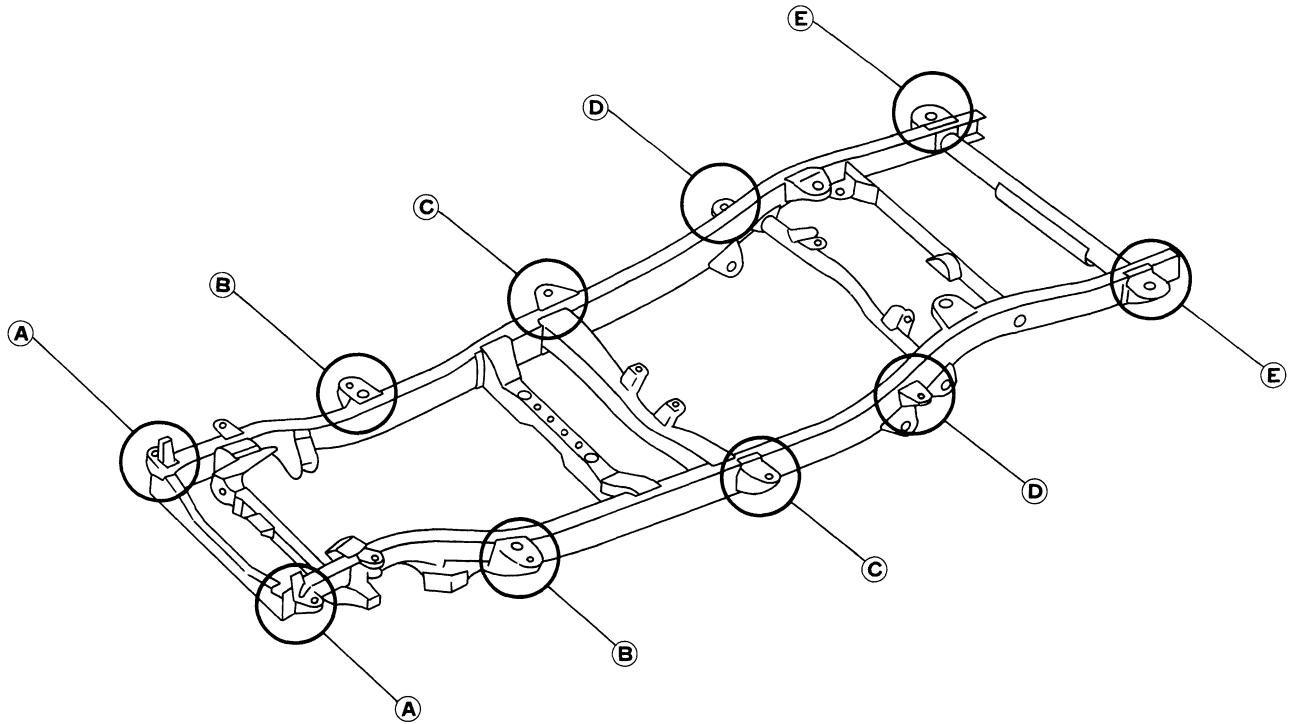

 27 - 37
(2.8 - 3.8, 20 - 27)

Section A

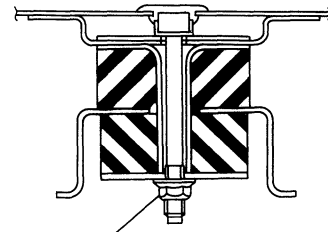

 27 - 37
(2.8 - 3.8, 20 - 27)

Section B and D

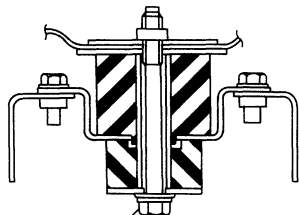

 27 - 37
(2.8 - 3.8, 20 - 27)

Section C

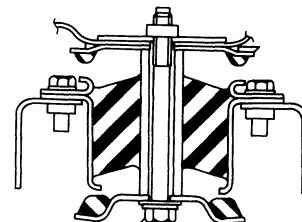

 27 - 37
(2.8 - 3.8, 20 - 27)

Section E

 : N·m (kg·m, ft·lb)

SBF379D

BODY ALIGNMENT

- All dimensions indicated in figures are actual ones.
- When a tram tracking gauge is used, adjust both pointers to equal length and check the pointers and gauge itself to make sure there is no free play.
- When a measuring tape is used, check to be sure there is no elongation, twisting or bending.
- Measurements should be taken at the center of the mounting holes.
- An asterisk (*) following the value at the measuring point indicates that the measuring point on the other side is symmetrically the same value.
- Measurement points

The coordinates of the measurement points are the distances measured from the respective dimension lines in the directions of "x", "y" and "z".

Dimension lines: "x" line – Center line of vehicle

"y" line – Center line of front axle (Any measurement point in front of the dimension line refers to a minus "-" value.)

"z" line – Datum line (Any measurement point under the dimension line refers to a minus "-" value.)

2W : 2WD

4W : 4WD

SB : Short wheelbase

LB : Long wheelbase

R : Regular Cab

K : King Cab

RL : Regular Cab (Long wheelbase)

2W.SB : Short wheelbase (2WD)

2W.LB : Long wheelbase (2WD)

4W.SB : Short wheelbase (4WD)

4W.LB : Long wheelbase (4WD)

MEASUREMENT

Engine Compartment

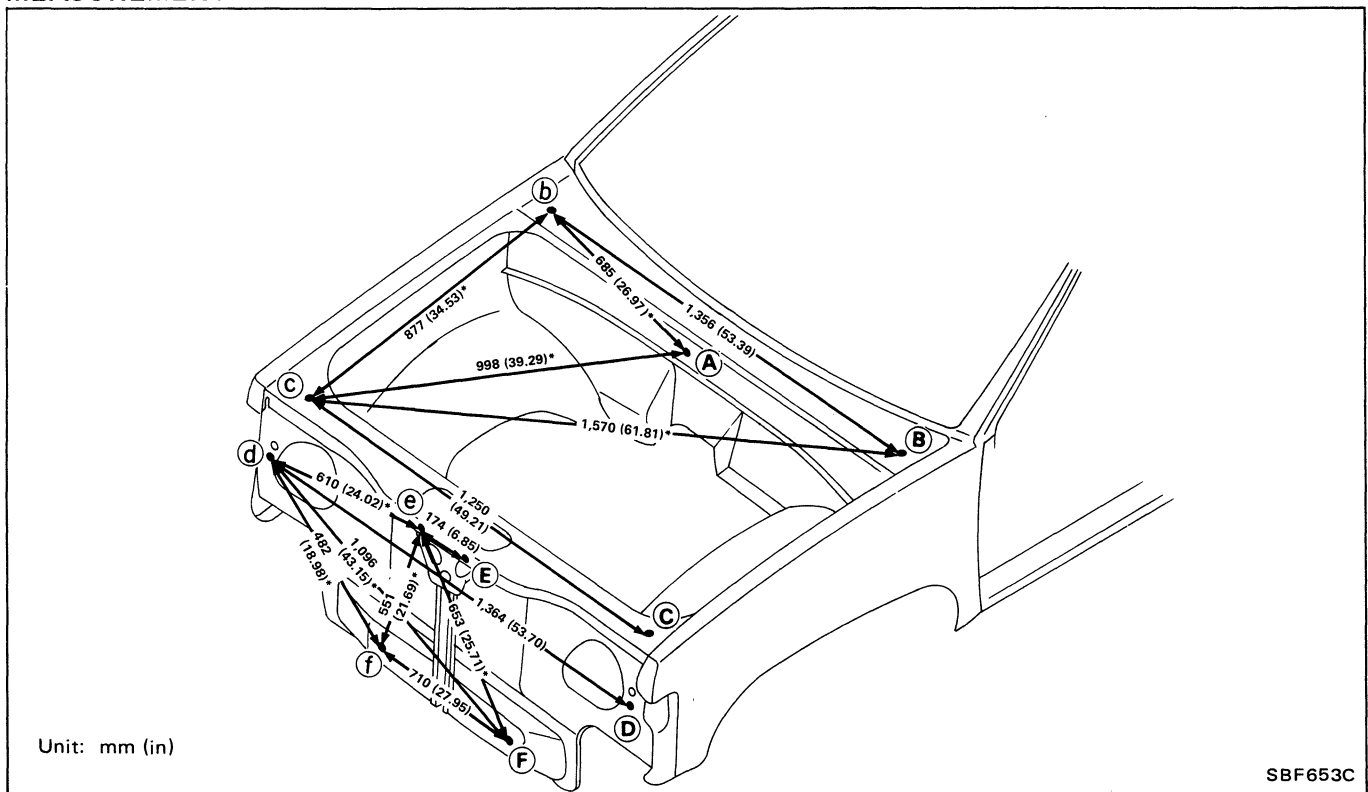

SBF653C

BODY ALIGNMENT

Engine Compartment (Cont'd)

DETAILED MEASUREMENT POINTS

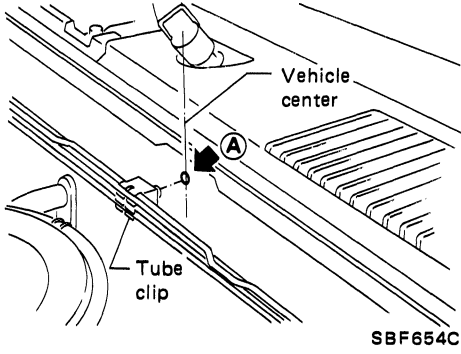
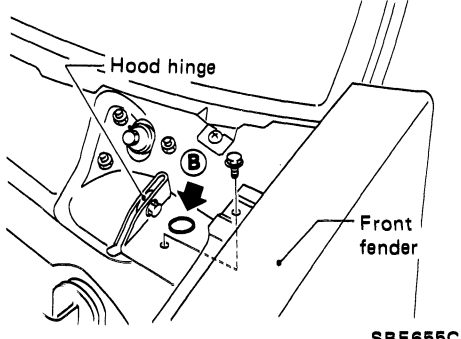
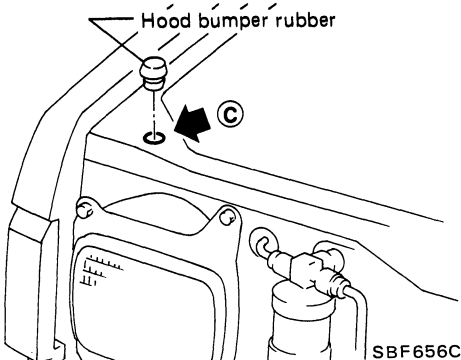
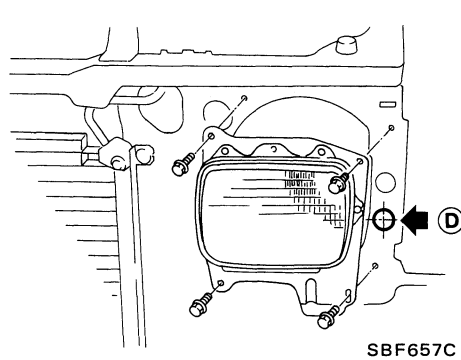
Points	Hole dia. mm (in)	Detailed points	Coordinates mm (in)		
			"x"	"y"	"z"
Ⓐ	7.5 x 11 (0.295 x 0.433)	 <p style="text-align: right;">SBF654C</p>	0.0 (0.00)	255.3 (10.05)	637.0 (25.08)
Ⓑ Ⓑ	16 (0.63)	 <p style="text-align: right;">SBF655C</p>	678.0 (26.69)	350.0 (13.78)	656.5 (25.85)
Ⓒ Ⓒ	30 (1.18)	 <p style="text-align: right;">SBF656C</p>	625.0 (24.61)	-514.0 (-20.24)	517.7 (20.38)
Ⓓ Ⓓ	18 (0.71)	 <p style="text-align: right;">SBF657C</p>	682.0 (26.85)	-553.5 (-21.79)	350.5 (13.80)

BODY ALIGNMENT

Engine Compartment (Cont'd)

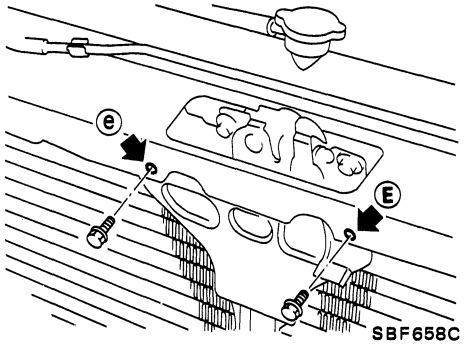
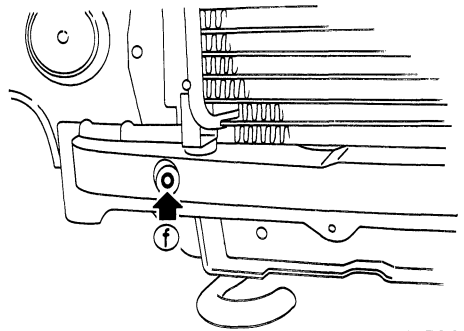
Points	Hole dia. mm (in)	Detailed points	Coordinates mm (in)		
			"x"	"y"	"z"
Ⓔ Ⓜ	9 x 12 (0.35 x 0.47)	 <p>Hole for hood lock stay mounting at radiator core upper support</p> <p>SBF658C</p>	87.0 (3.425)	-589.8 (-23.22)	481.0 (18.94)
Ⓕ Ⓨ	12 (0.47)	 <p>Hole for locating at radiator core lower support</p> <p>SBF659C</p>	355.0 (13.98)	-602.8 (-23.73)	0.0 (0.00)

BODY ALIGNMENT

Underbody—TRUCK

MEASUREMENT POINTS

2WD models

- R : Regular Cab
- K : King Cab
- RL : Regular Cab (Long wheelbase)

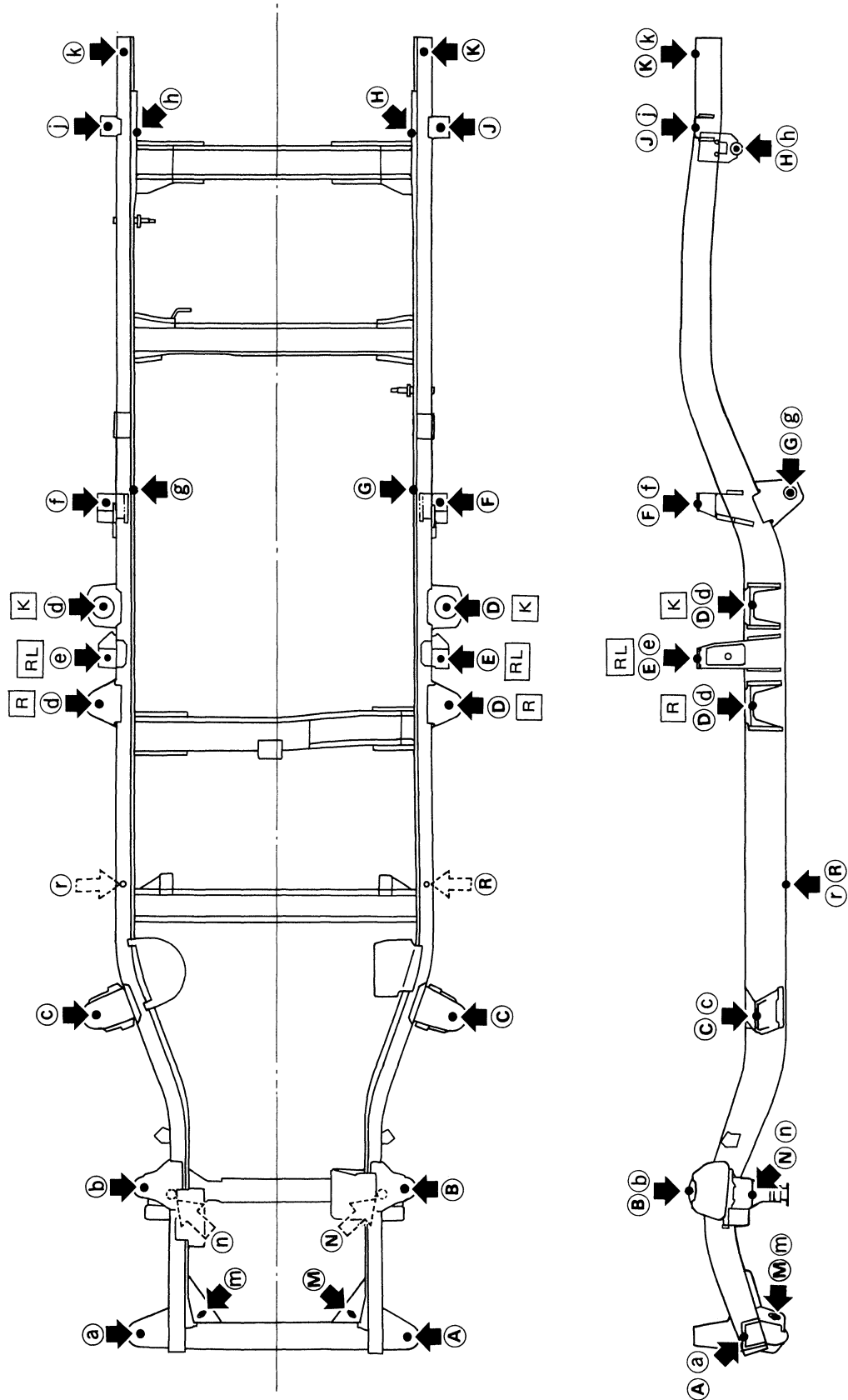

BODY ALIGNMENT

Underbody—TRUCK (Cont'd)

MEASUREMENT POINTS

4WD models

- R : Regular Cab
- K : King Cab
- RL : Regular Cab (Long wheelbase)

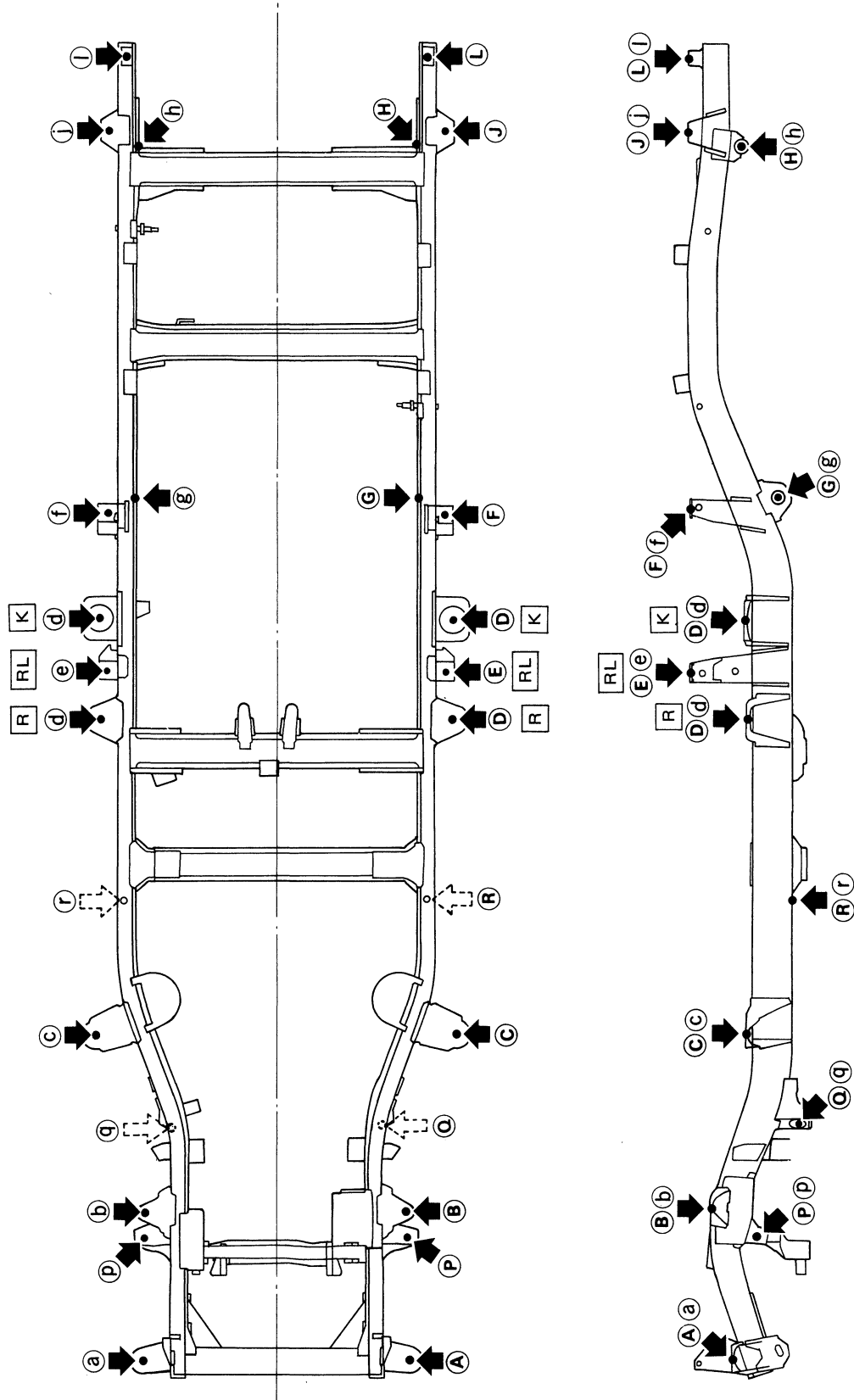

BODY ALIGNMENT

Underbody—TRUCK (Cont'd)

MEASUREMENT

2WD models

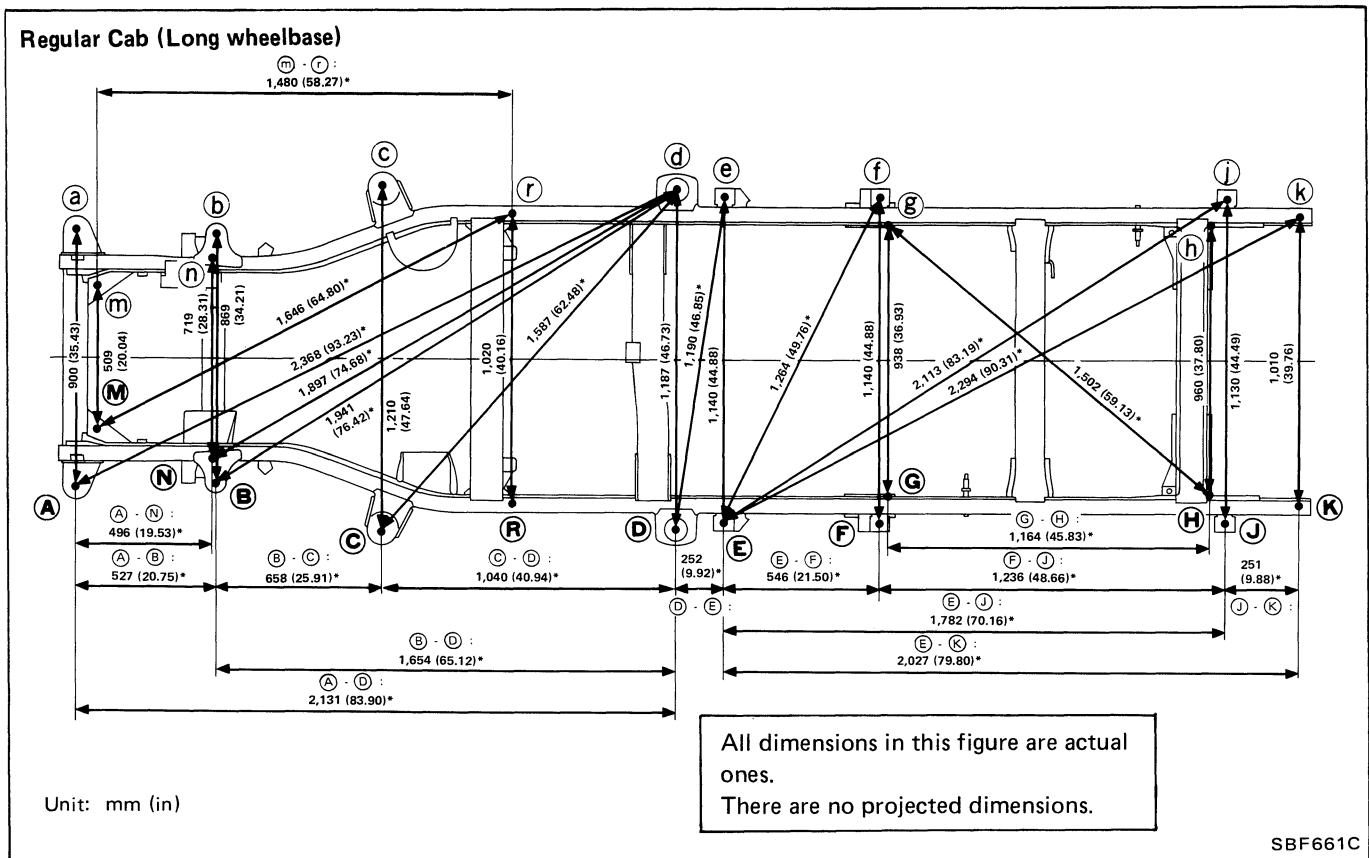
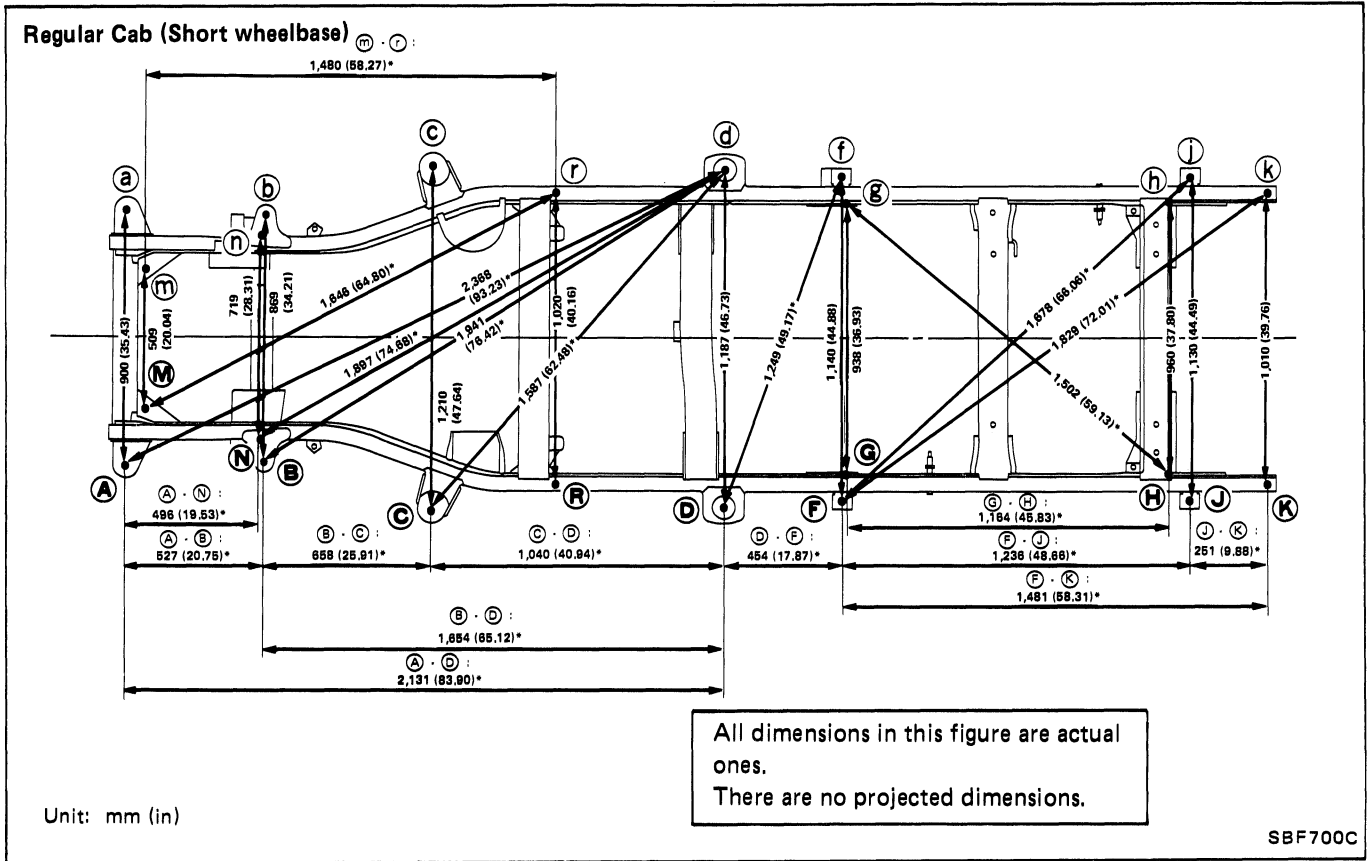

BODY ALIGNMENT

Underbody—TRUCK (Cont'd)

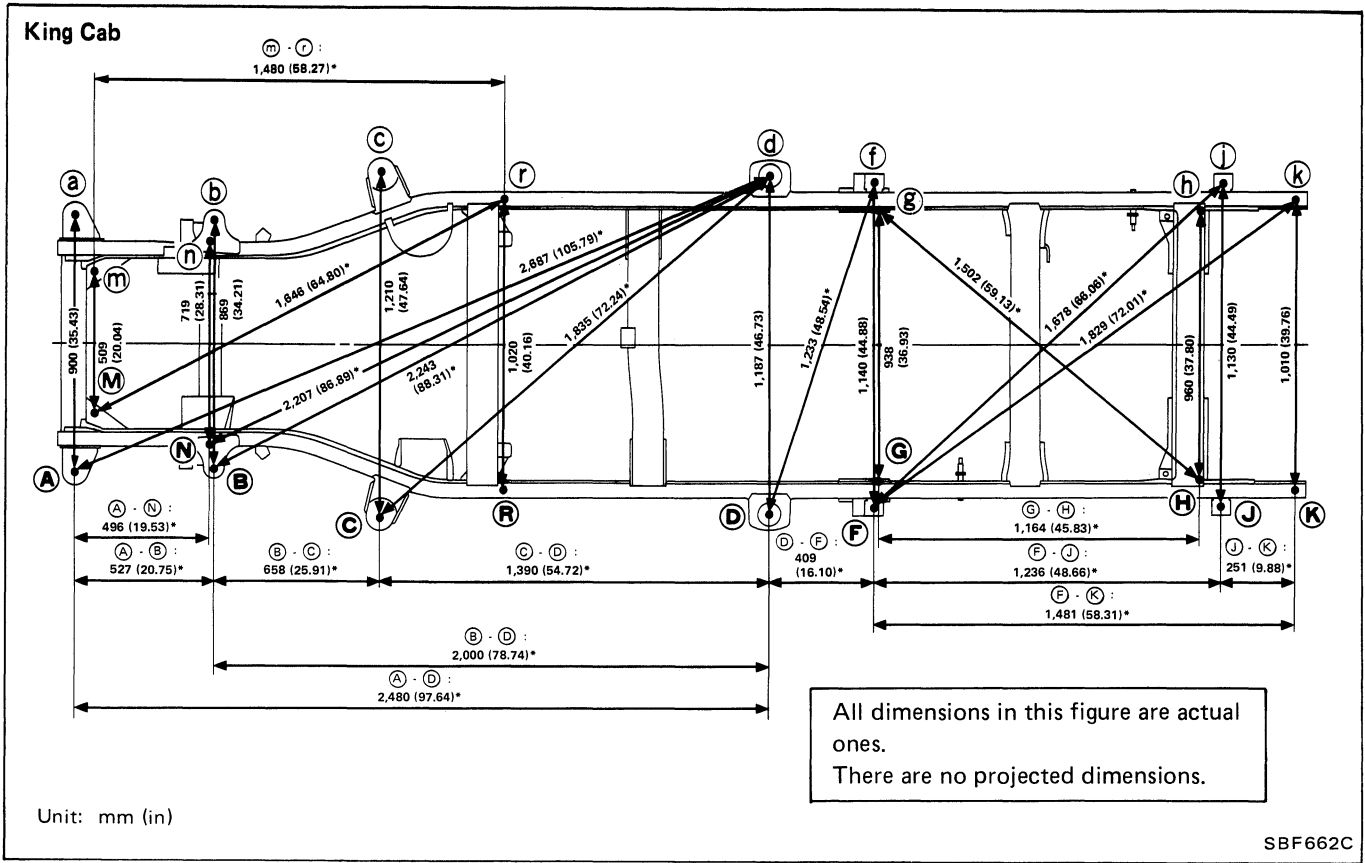

4WD models

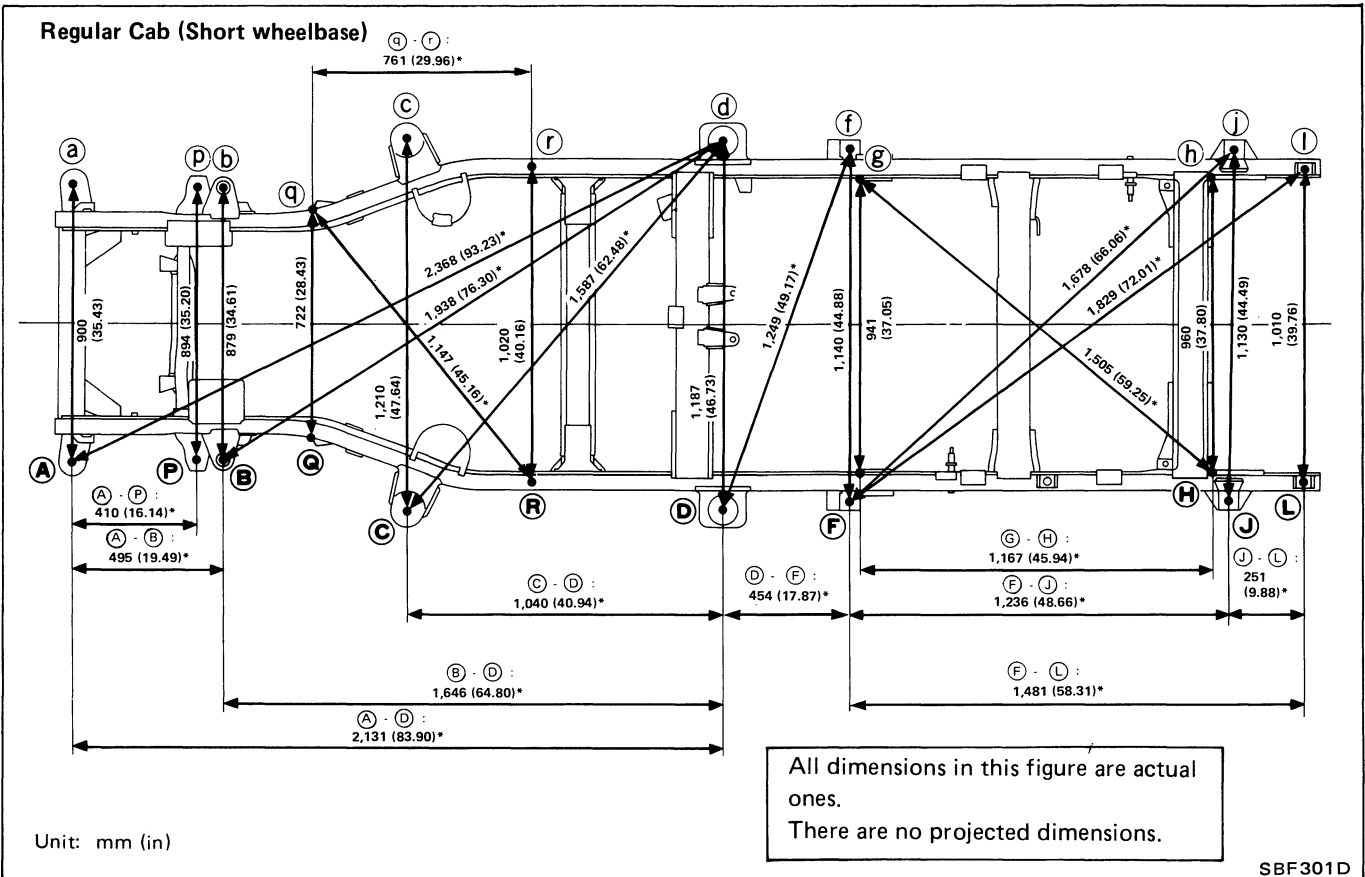

BODY ALIGNMENT

Underbody—TRUCK (Cont'd)

Regular Cab (Long wheelbase)

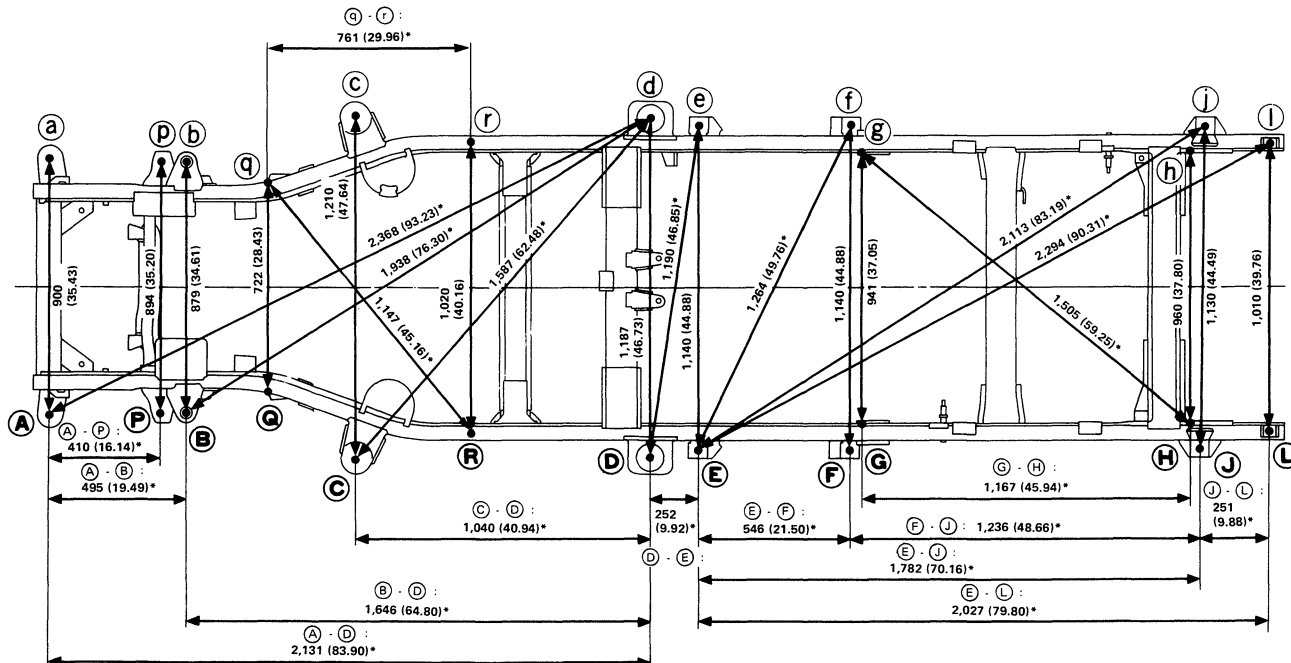

Unit: mm (in)

All dimensions in this figure are actual ones.
There are no projected dimensions.

SBF302D

King Cab

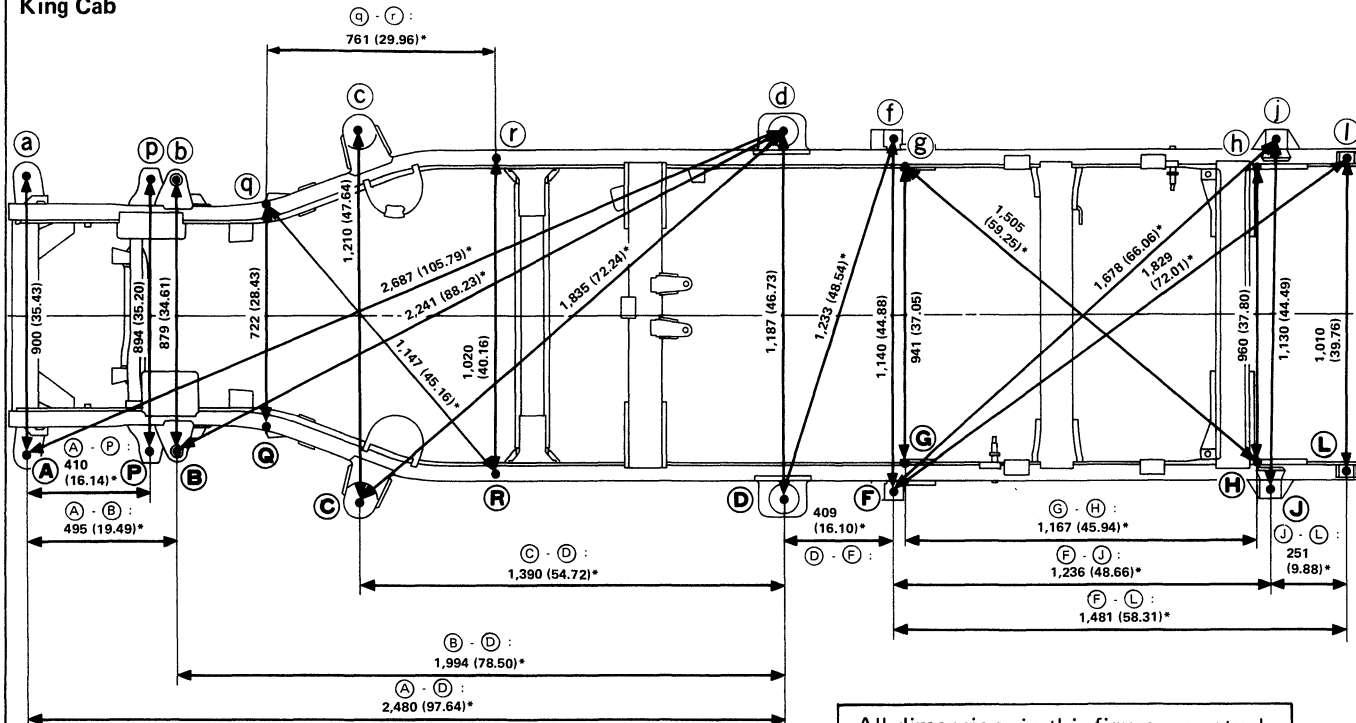

Unit: mm (in)

All dimensions in this figure are actual ones.
There are no projected dimensions.

SBF303D

BODY ALIGNMENT

Underbody—TRUCK (Cont'd)

DETAILED MEASUREMENT POINTS

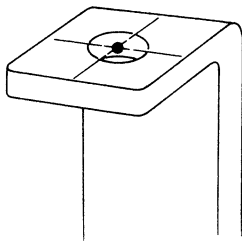
Points	Hole dia. mm (in)	Detailed points		Coordinates mm (in)		
				"x"	"y"	"z"
Ⓐ ⓐ	24 (0.94)	 <p style="text-align: center;">Center of hole on top of bracket</p> <p style="text-align: right;">SBF274B</p>	Cab body or rear body mounting insulator mounting hole	450.0 (17.72)	-488.5 (-19.23)	2W : 21.2 (0.835) 4W : 71.2 (2.803)
Ⓒ Ⓒ	28 (1.10)			605.0 (23.82)	597.5 (23.52)	2W : -28.2 (-1.110) 4W : 21.8 (0.858)
Ⓓ ⓓ	85 (3.35)			593.5 (23.37)	R : 1,637.0 (64.45) K : 1,987.0 (78.23)	2W : -15.0 (-0.591) 4W : 35.0 (1.378)
Ⓔ ⓔ	18 (0.71)			RL : 570.0 (22.44)	RL : 1,804.0 (71.02)	2W : 171.8 (6.76) 4W : 221.8 (8.73)
Ⓕ ⓕ	18 (0.71)			570.0 (22.44)	SB : 2,050.0 (80.71) LB : 2,350.0 (92.52)	2W : 171.8 (6.76) 4W : 221.8 (8.73)

BODY ALIGNMENT

Underbody—TRUCK (Cont'd)

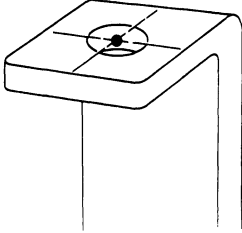
Points	Hole dia. mm (in)	Detailed points		Coordinates mm (in)		
				"x"	"y"	"z"
ⓐ ⓑ	18 (0.71)	<p style="text-align: center;">Center of hole on top of bracket</p>  <p style="text-align: right;">SBF274B</p>	<p style="text-align: center;">Cab body or rear body mounting insulator mounting hole</p>	565.0 (22.24)	SB : 3,286.0 (129.37) LB : 3,586.0 (141.18)	2W : 171.8 (6.76) 4W : 221.8 (8.73)
				505.0 (19.88)	SB : 3,530.0 (138.98) LB : 3,830.0 (150.79)	220.0 (8.66)

BODY ALIGNMENT

Underbody—TRUCK (Cont'd)

Points	Hole dia. mm (in)	Detailed points	Coordinates mm (in)			
			"x"	"y"	"z"	
<p>(B) (b)</p>	<p>2W : 15 (0.59) 4W : 15.3 (0.602)</p>	<p>2WD 4WD</p> <p>SBF668C</p>	<p>Hole for front shock absorber mounting at the bracket</p>	<p>2W : 434.7 (17.11) 4W : 439.7 (17.31)</p>	<p>2W : 5.6 (0.220) 4W : 1.4 (0.055)</p>	<p>2W : 203.2 (8.00) 4W : 142.0 (5.59)</p>
<p>(G) (g)</p>	<p>12 (0.47)</p>	<p>Front</p> <p>Front mounting bracket</p> <p>Inner side</p> <p>SBF669C</p>	<p>Hole for rear spring front mounting at the bracket</p>	<p>2W : 469.0 (18.46) 4W : 470.5 (18.52)</p>	<p>2W.SB : 2,059.0 (81.06) 2W.LB : 2,359.0 (92.87) 4W.SB : 2,080.0 (81.89) 4W.LB : 2,380.0 (93.70)</p>	<p>2W : -152.0 (-5.98) 4W : -86.0 (-3.386)</p>
<p>(H) (h)</p>	<p>33 (1.30)</p>	<p>Front</p> <p>Rear mounting bracket</p> <p>Inner side</p> <p>SBF670C</p>	<p>Hole for rear spring rear mounting at the bracket</p>	<p>480.0 (18.90)</p>	<p>2W.SB : 3,209.0 (126.34) 2W.LB : 3,509.0 (138.15) 4W.SB : 3,240.0 (127.56) 4W.LB : 3,540.0 (139.37)</p>	<p>2W : 30.0 (1.181) 4W : 43.0 (1.693)</p>
<p>(K) (k)</p>	<p>22 (0.87)</p>	<p>Side member outer</p> <p>SBF671C</p>	<p>Hole for body mounting at rear of side member outer</p>	<p>505.0 (19.88)</p>	<p>SB : 3,530.0 (138.98) LB : 3,830.0 (150.79)</p>	<p>170.0 (6.69)</p>

BODY ALIGNMENT

Underbody—TRUCK (Cont'd)

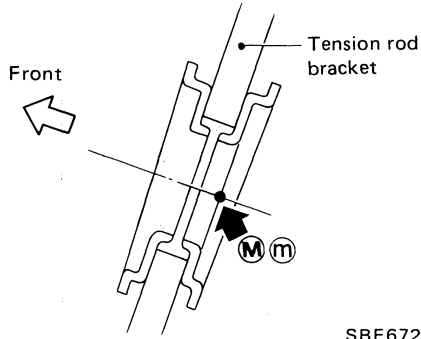
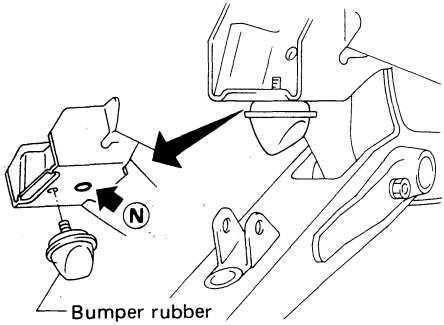
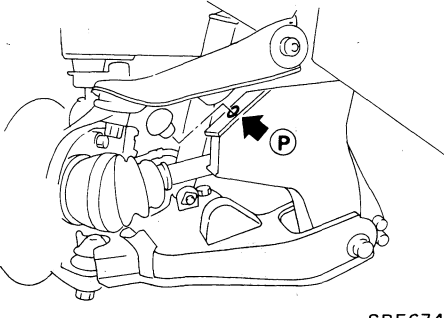
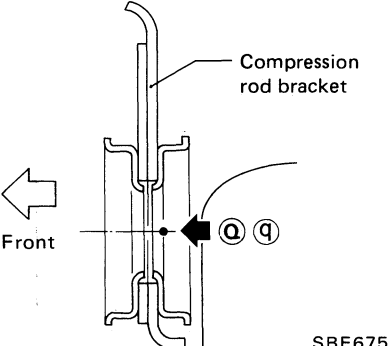
Points	Hole dia. mm (in)	Detailed points	Coordinates mm (in)		
			"x"	"y"	"z"
<p>Ⓜ Ⓜ</p>	27 (1.06)	 <p>Front</p> <p>Tension rod bracket</p> <p>Hole for tension rod mounting at the bracket</p> <p>SBF672C</p>	254.6 (10.02)	-417.1 (-16.42)	-92.3 (-3.634)
<p>Ⓝ Ⓝ</p>	9 (0.35)	 <p>Bumper rubber</p> <p>Hole for locating at bound bumper bracket</p> <p>SBF673C</p>	359.5 (14.15)	-3.2 (-0.126)	-23.5 (-0.925)
<p>Ⓟ Ⓟ</p>	10.5 (0.413)	 <p>Hole for rebound bumper mounting at lower link bracket</p> <p>SBF674C</p>	447.0 (17.60)	-88.0 (-3.465)	-14.9 (-0.587)
<p>Ⓠ Ⓠ</p>	27 (1.06)	 <p>Front</p> <p>Compression rod bracket</p> <p>Hole for compression rod mounting at the bracket</p> <p>SBF675C</p>	361.1 (14.22)	294.5 (11.59)	-158.9 (-6.26)

BODY ALIGNMENT

Underbody—TRUCK (Cont'd)

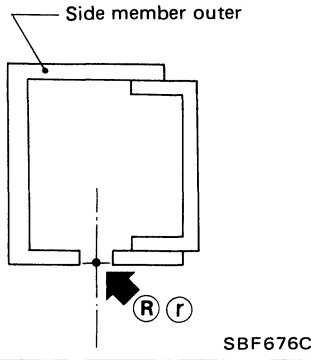
Points	Hole dia. mm (in)	Detailed points		Coordinates mm (in)		
				"x"	"y"	"z"
Ⓡ Ⓡ	13 (0.51)	 <p>Hole for waxing at lower side of side member outer</p>	510.0 (20.08)	1,040.0 (40.94)	-135.0 (-5.31)	

BODY ALIGNMENT

Underbody—VAN & WAGON

MEASUREMENT POINTS

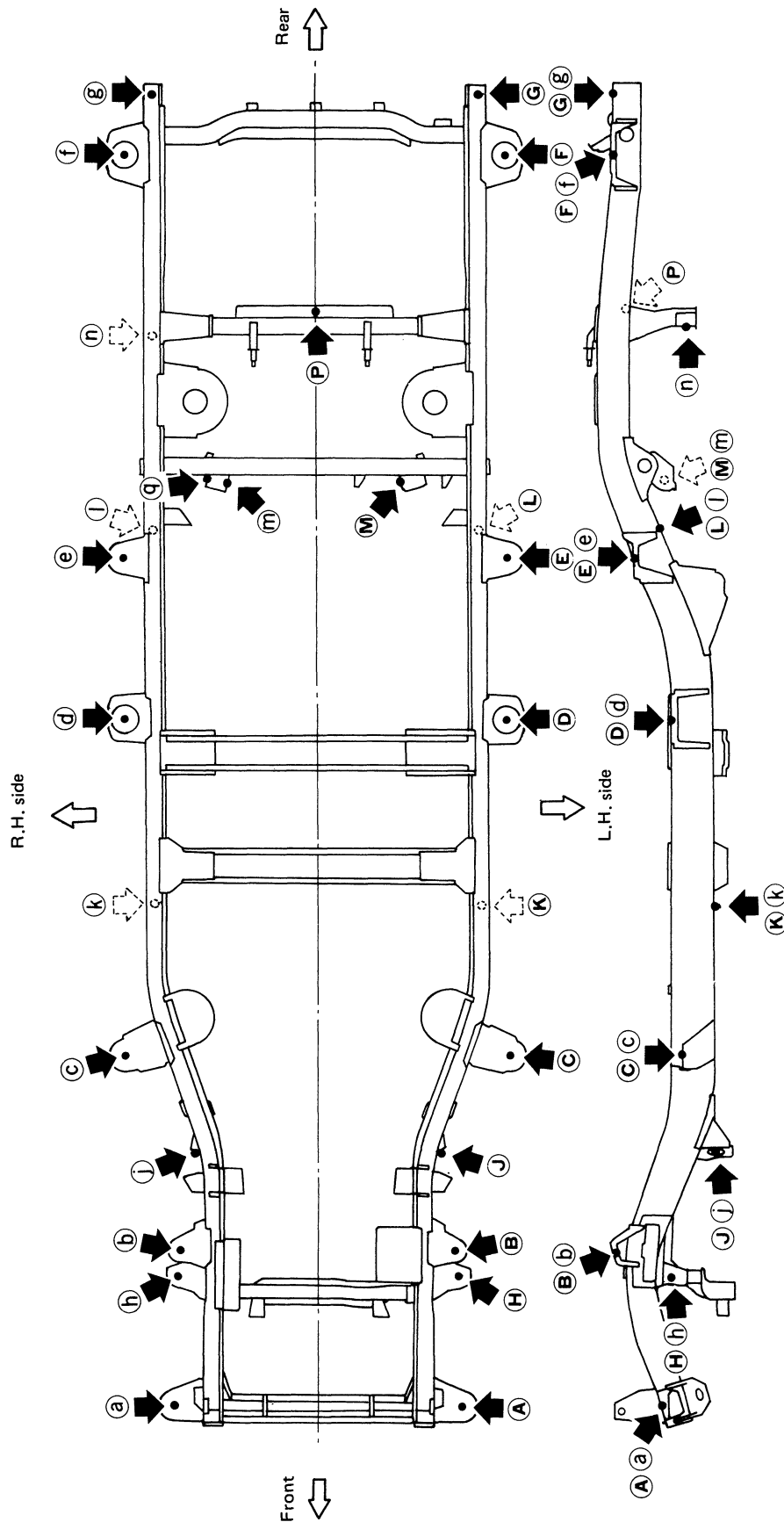

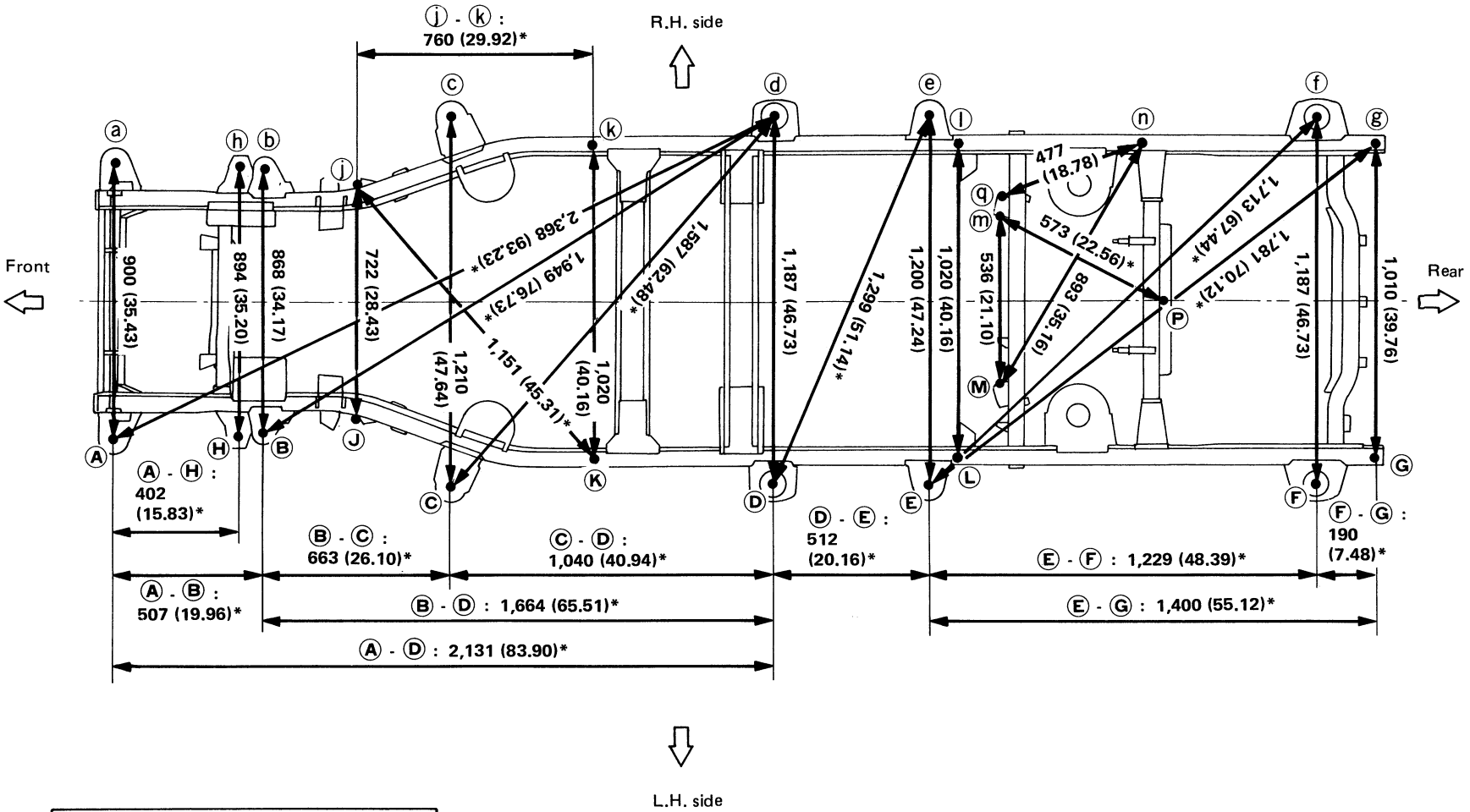

All dimensions in this figure are actual ones.
There are no projected dimensions.

Unit: mm (in)

BF-65

BODY ALIGNMENT

Underbody—VAN & WAGON (Cont'd)

DETAILED MEASUREMENT POINTS

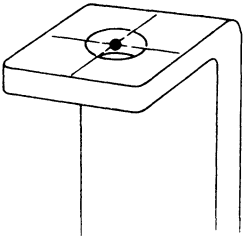
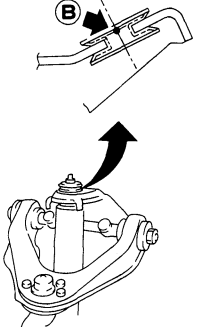
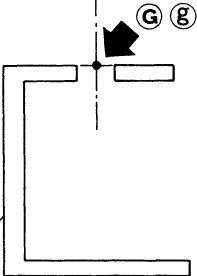
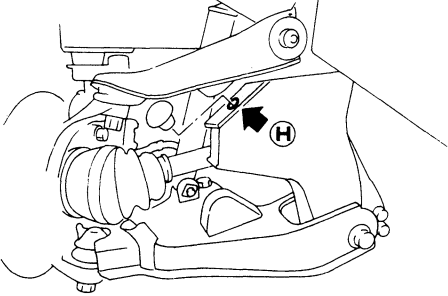
Points	Hole dia. mm (in)	Detailed points	Coordinates mm (in)		
			"x"	"y"	"z"
(A) (a)	24 (0.94)	 <p style="text-align: center;">Center of hole on top of bracket</p> <p style="text-align: right;">SBF274B</p>	450.0 (17.72)	-488.5 (-19.23)	21.2 (0.835)
(C) (c)	28 (1.10)		605.0 (23.82)	597.5 (23.52)	-28.2 (-1.110)
(D) (d)	85 (3.35)		593.5 (23.37)	1,637.0 (65.87)	-15 (-0.591)
(E) (e)	28 (1.10)		600.0 (23.62)	2,135.0 (84.05)	104.7 (4.12)
(F) (f)	85 (3.35)		593.5 (23.37)	3,362.0 (132.36)	170 (6.69)
(B) (b)	13 (0.51)	 <p style="text-align: right;">SBF381D</p>	434.0 (17.09)	-7.7 (-0.303)	181.9 (7.16)
(G) (g)	25 (0.98)	 <p style="text-align: center;">Side member outer</p> <p style="text-align: right;">SBF671C</p>	505.0 (19.88)	3,530.0 (138.98)	170.0 (6.69)
(H) (h)	10.5 (0.413)	 <p style="text-align: right;">SBF674C</p>	447.0 (17.60)	-88.0 (-3.465)	-14.9 (-0.587)

BODY ALIGNMENT

Underbody—VAN & WAGON (Cont'd)

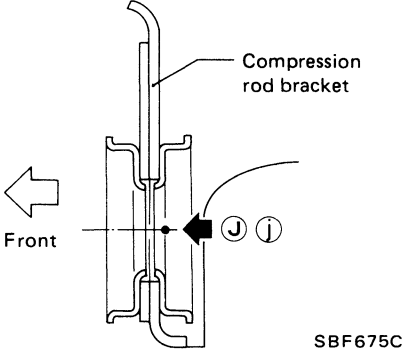
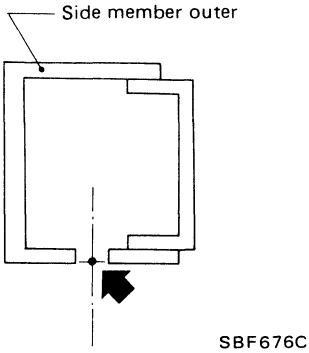
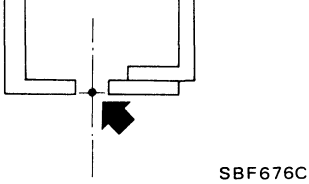
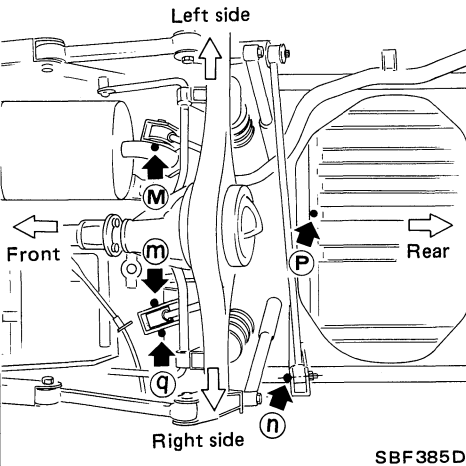
Points	Hole dia. mm (in)	Detailed points	Coordinates mm (in)			
			"x"	"y"	"z"	
ⓐ ⓑ	27 (1.06)	 <p>Compression rod bracket</p> <p>Hole for compression rod mounting at the bracket</p> <p>SBF675C</p>	361.1 (14.22)	294.5 (11.59)	-158.9 (-6.26)	
ⓓ ⓔ	13 (0.51)	 <p>Side member outer</p> <p>Hole for waxing at lower side of side member outer</p> <p>SBF676C</p>	510.0 (20.08)	1,040.0 (40.94)	-135.0 (-5.31)	
ⓕ ⓖ	13 (0.51)	 <p>Hole for torque arrester mounting at lower side of side member outer</p> <p>SBF676C</p>	510.0 (20.08)	2,210.0 (87.01)	17.2 (0.677)	
ⓓ ⓔ	14 (0.55)	 <p>Left side</p> <p>Right side</p> <p>Front</p> <p>Rear</p> <p>SBF385D</p>	268.0 (10.55)	2,381.6 (93.76)	5.0 (0.197)	
ⓖ	14 (0.55)		Hole for upper link mounting at the bracket	332.0 (13.07)	2,396.4 (94.35)	5.0 (0.197)
ⓗ	14 (0.55)		Hole for panhard rod mounting at front portion of the bracket	496 (19.53)	2,840.5 (111.83)	-55 (-2.17)
ⓓ	11 (0.43)	Hole for fuel tank mounting at vehicle center	0.0 (0.00)	2,878.0 (113.31)	106.0 (4.17)	

HEATER & AIR CONDITIONER

SECTION **HA**

CONTENTS

AIR FLOW AND COMPONENT LAYOUT	HA- 2
DOOR CONTROL	HA- 4
HEATER ELECTRICAL CIRCUIT	HA- 6
PRECAUTIONS	HA- 7
PRECAUTIONS FOR REFRIGERANT CONNECTION	HA- 8
PREPARATION	HA- 9
DISCHARGING, EVACUATING, CHARGING AND CHECKING	HA-11
PIPING, COMPRESSOR MOUNTING AND F.I.C.D.	HA-17
A/C PERFORMANCE TEST	HA-22
COMPRESSOR OIL – For DKV-14C (DIESEL-KIKI make)	HA-24
COMPRESSOR – Model DKV-14C (DIESEL-KIKI make)	HA-26
A/C ELECTRICAL CIRCUIT	HA-30
A/C ELECTRICAL COMPONENTS	HA-32
A/C COMPONENT LAYOUT	HA-33
SERVICE DATA AND SPECIFICATIONS (S.D.S.)	HA-34

When you read wiring diagrams:

- Read GI section, "HOW TO READ WIRING DIAGRAMS".
- See EL section, "POWER SUPPLY ROUTING" for power distribution circuit.

AIR FLOW AND COMPONENT LAYOUT

Air Flow

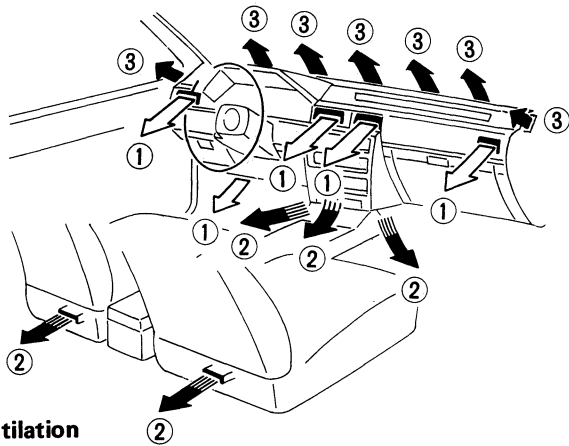

Ventilation

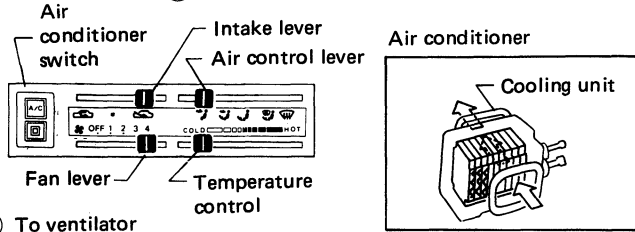

① To ventilator

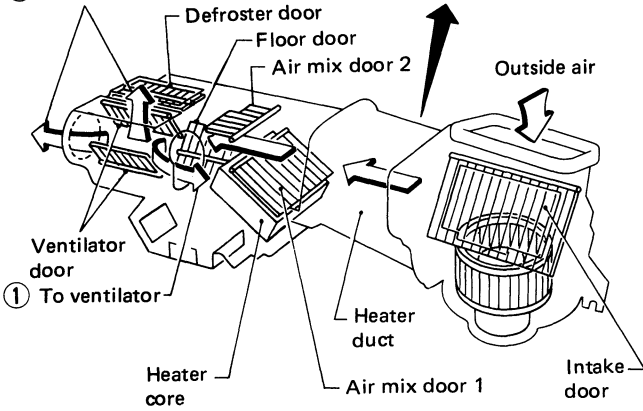

① To ventilator

Floor

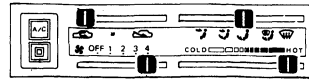

③ To defroster

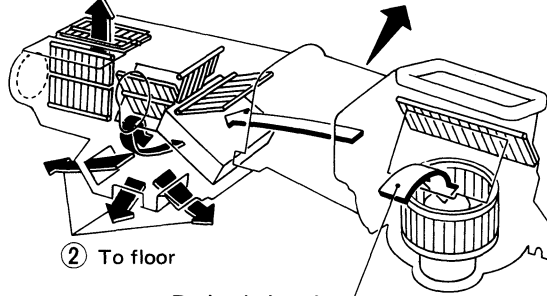

② To floor

Recirculation air

Floor and defroster

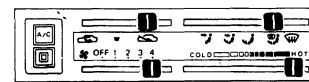

③ To defroster

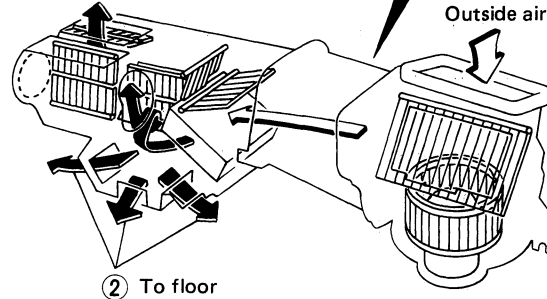

② To floor

Outside air

Bi-level

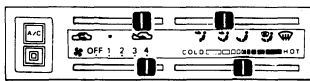

① To ventilator

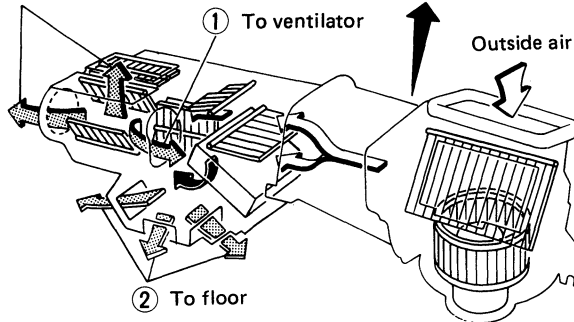

② To floor

Defroster

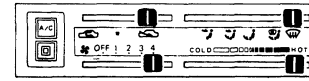

③ To defroster

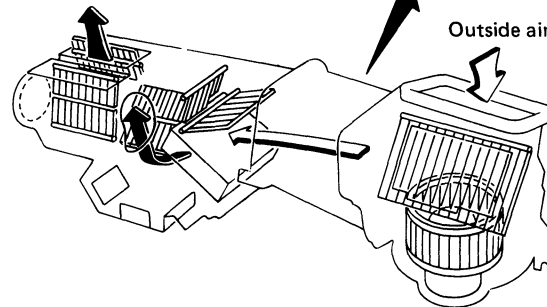

Outside air

➡ : Air passed through heater core

➡ : Air not passed through heater core

➡ : Mixed air (➡ + ➡)

Component Layout

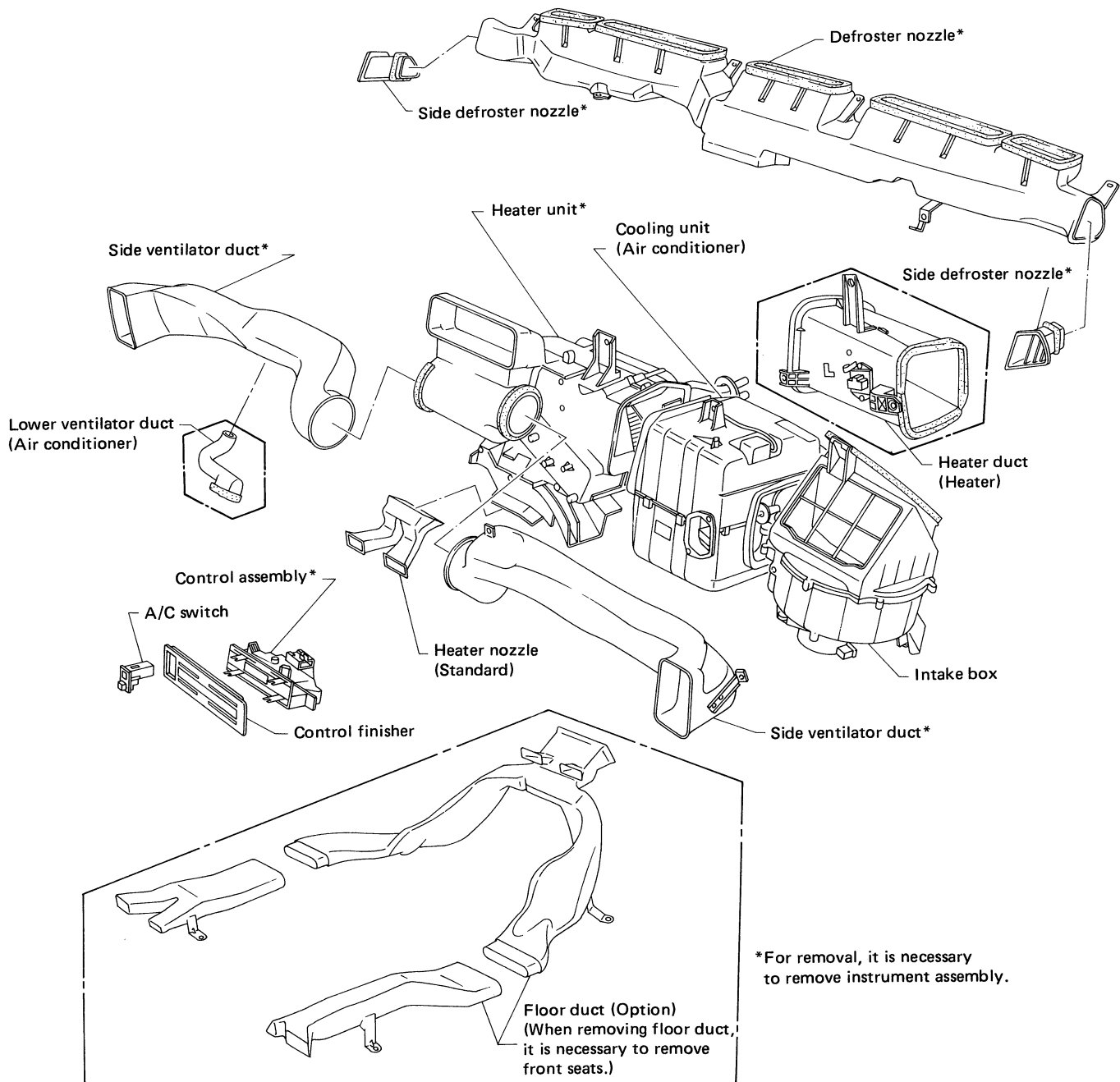

HA-3

SHA956B

DOOR CONTROL

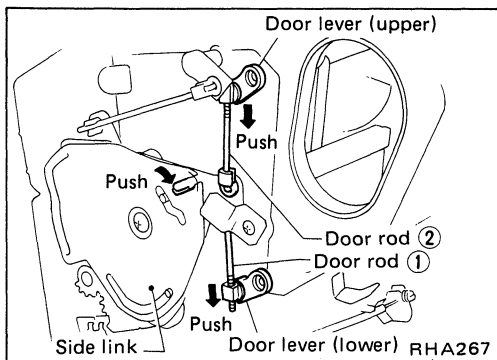

Control Cable and Rod Adjustment

- When adjusting ventilator door rod and defroster door rod, first disconnect air control cable from side link. Reconnect and readjust air control cable.

VENTILATOR DOOR CONTROL ROD

1. Move side link in direction of arrow.
2. With upper and lower ventilator door levers held in the direction of the arrow, connect rods ① and ② to their corresponding ventilator door levers in that order.

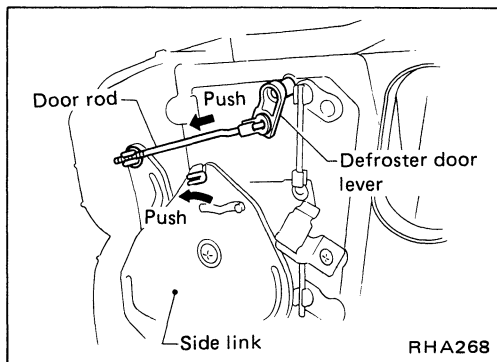

DEFROSTER DOOR CONTROL ROD

1. Move side link in direction of arrow.
2. Connect rod to side link while pushing defroster door lever in direction of arrow.

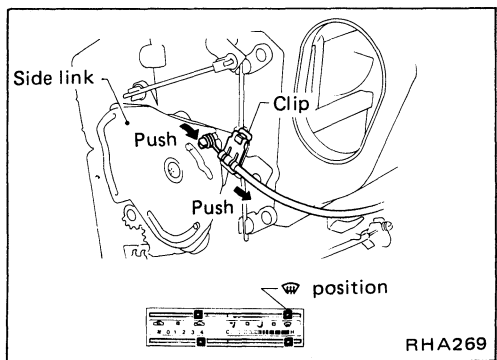

AIR CONTROL CABLE

- Clamp the cable while pushing cable outer and side link in direction of arrow.

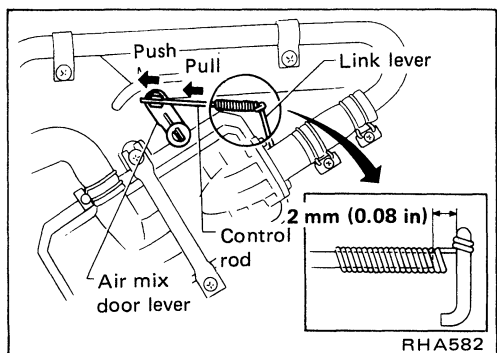

WATER COCK CONTROL ROD

- When adjusting water cock control rod, first disconnect temperature control cable from air mix door lever and then adjust control rod. Reconnect temperature control cable and readjust it. (Refer to next item.)
1. Push air mix door lever in direction of arrow.
 2. Pull control rod of water cock in direction of arrow so as to make clearance of about 2 mm (0.08 in) between ends of rod and link lever and connect the rod to door lever.

DOOR CONTROL

Control Cable and Rod Adjustment (Cont'd)

TEMPERATURE CONTROL CABLE

- Clamp the cable while pushing cable outer and air mix door lever in direction of arrow.

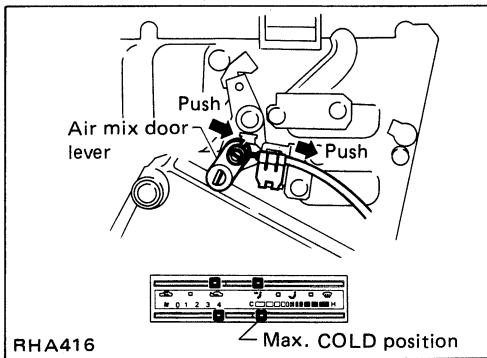

INTAKE DOOR CONTROL CABLE

- Clamp the cable while pushing cable outer and intake door lever in direction of arrow.

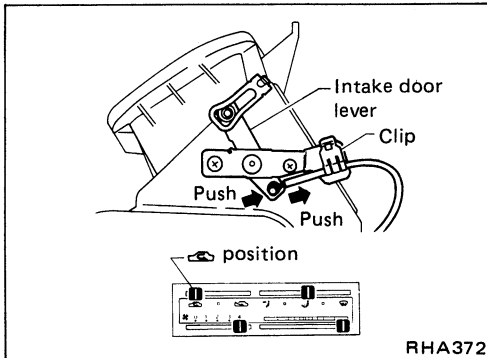

HEATER ELECTRICAL CIRCUIT

Wiring Diagram

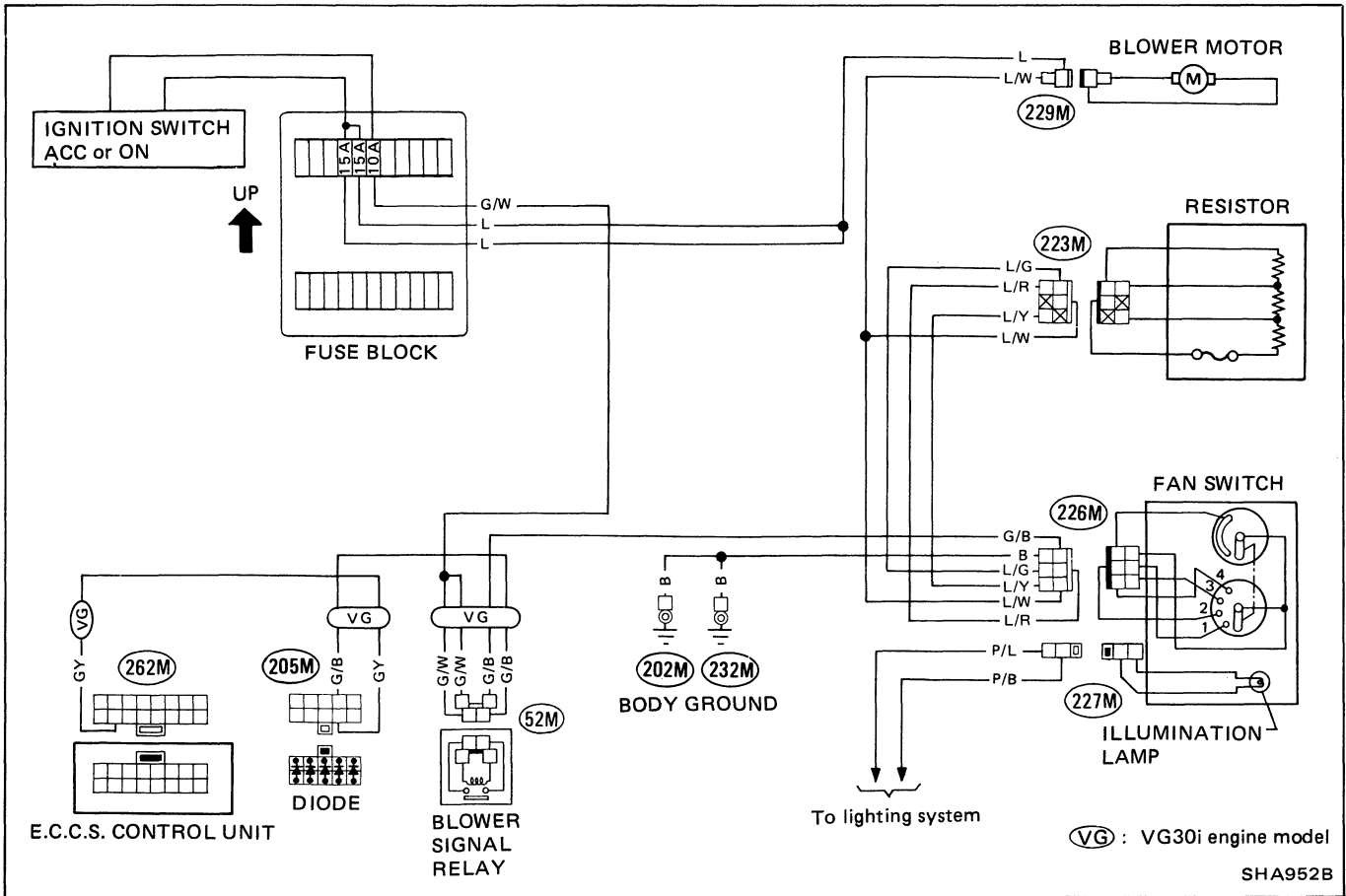

Fan Switch Check

Fan switch

LEVER POSITION	OFF	1	2	3	4
1					○
2		○			○
3			○		
4				○	
5		○	○	○	○
6		○	○	○	○
7		○			
8		○	○		

○ Illumination lamp

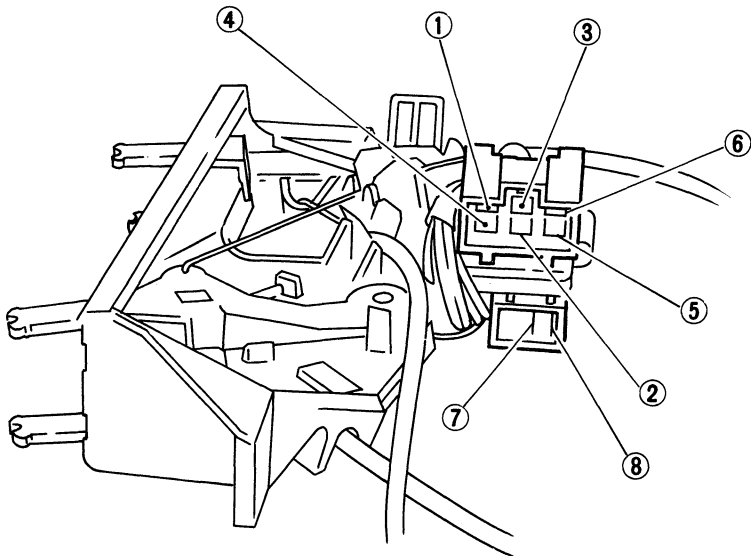

RHA374

PRECAUTIONS

WARNING:

- Always wear eye protection when working around the system.
- Always be careful that refrigerant does not come in contact with your skin.
- Keep refrigerant containers stored below 40°C (104°F) and never drop from high places.
- Work in well-ventilated area because refrigerant gas evaporates quickly and breathing may become difficult due to the lack of oxygen.
- Keep refrigerant away from open flames because poisonous gas will be produced if it burns.
- Do not increase can temperature beyond 40°C (104°F) in charging.
- Do not heat refrigerant can with an open flame. There is danger that can will explode.

CAUTION:

- Do not use steam to clean surface of condenser or evaporator. Be sure to use cold water or compressed air.
- Compressed air must never be used to clean a dirty line. Clean with refrigerant gas.

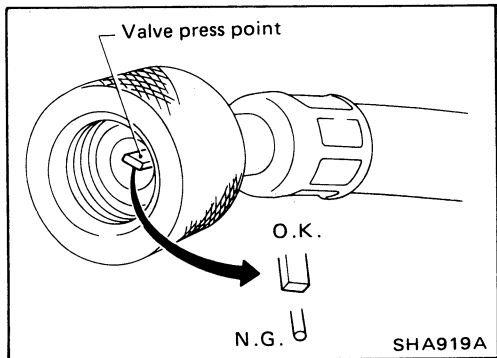

- Do not use manifold gauge whose press point shape is different from that shown. Otherwise, insufficient evacuating may occur.

- Do not over-tighten service valve cap.
- Do not allow refrigerant to rush out. Otherwise, compressor oil will be discharged along with refrigerant.

PRECAUTIONS FOR REFRIGERANT CONNECTION

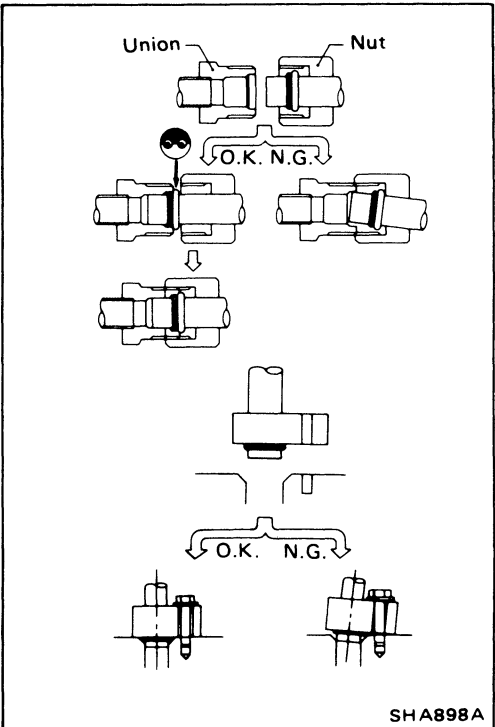
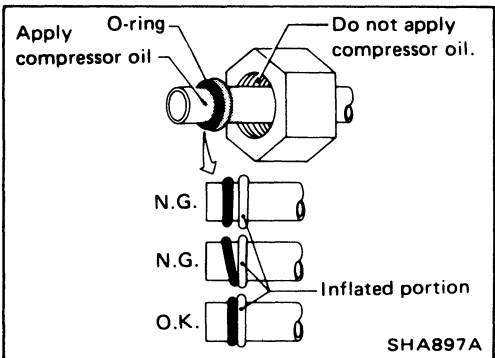
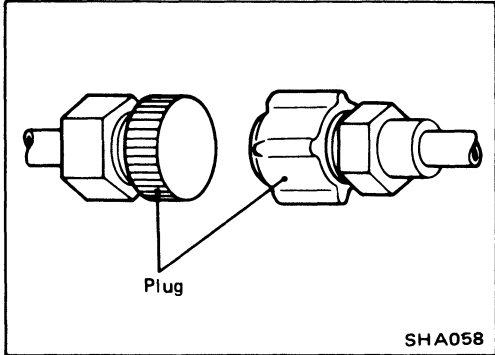
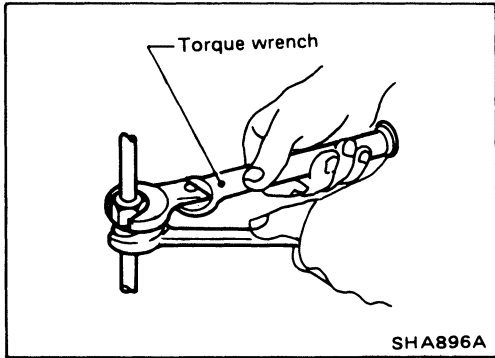

WARNING:

Gradually loosen discharge side hose fitting, and remove it after remaining pressure has been released.

CAUTION:

When replacing or cleaning refrigerant cycle components, observe the following.

- Do not leave compressor on its side or upside down for more than 10 minutes, as compressor oil will enter low pressure chamber.
- When connecting tubes, always use a torque wrench.

- After disconnecting tubes, plug all openings immediately to prevent entrance of dirt and moisture.

- Always replace used O-rings.
- When connecting tube, apply compressor oil to portions shown in illustration. Be careful not to apply oil to threaded portion.
- O-ring must be closely attached to inflated portion of tube.

- After inserting tube into union until O-ring is no longer visible, tighten nut to specified torque.
- After connecting line, conduct leak test and make sure that there is no leakage from connections. When the gas leaking point is found, disconnect that line and replace the O-ring. Then tighten connections of seal seat to the specified torque.

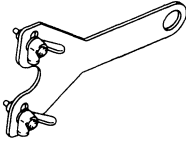
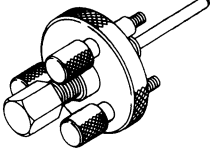
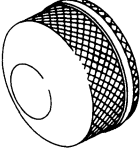

PREPARATION

SPECIAL SERVICE TOOLS

Tool number (Kent-Moore No.) Tool name	Description
KV99231162 (-) Clutch disc wrench	 Removing shaft nut and clutch disc
KV99232340 (-) Clutch disc puller	 Removing clutch disc
KV99234330 (-) Pulley installer	 Installing pulley

PREPARATION

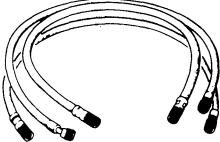
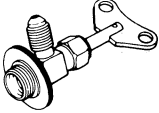
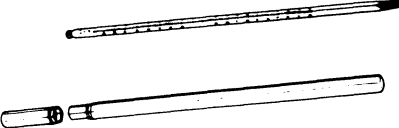
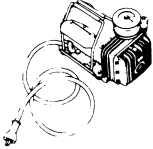
SERVICE TOOLS

Tool name	Description
Manifold gauge	 <p>Using discharge and charge refrigerant into system</p>
Charging hose	 <p>Using discharge and evacuate, charge refrigerant into system</p>
Charge valve	 <p>Using discharge and charge refrigerant into system</p>
Thermometer	 <p>Using check temperature</p>
Vacuum pump	 <p>Using evacuate refrigerant system</p>
Electric leak-detector	<p>Nominal sensitivity: 15 - 25 g (0.53 - 0.88 oz)/year</p>  <p>Using check refrigerant leaks</p>

DISCHARGING, EVACUATING, CHARGING AND CHECKING

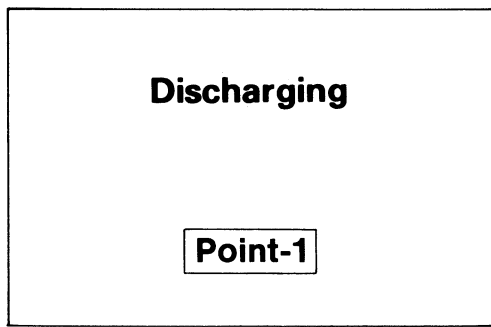

Discharge refrigerant system.

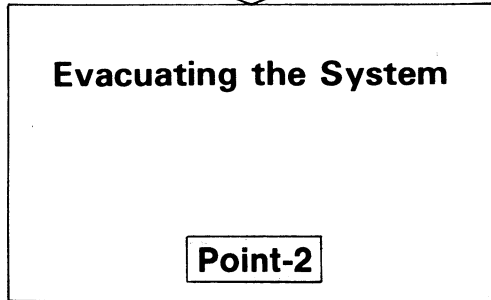

Run pump for 5 minutes.

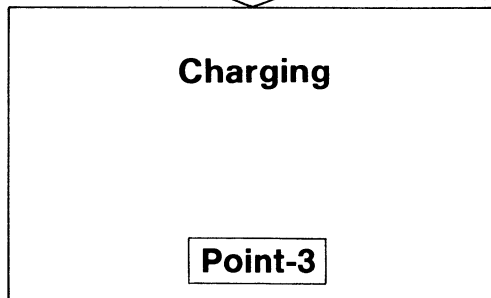

Charge refrigerant into system.

When low-pressure gauge reading is 98 kPa (1.0 kg/cm², 14 psi), completely close high-pressure valve of manifold gauge and stop charging.

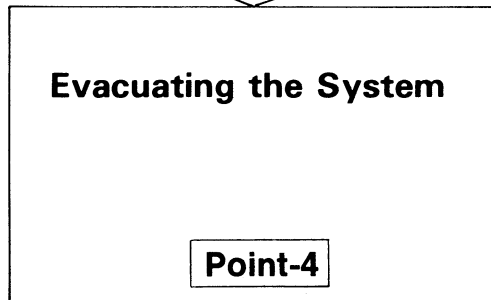

Run pump for 20 minutes.

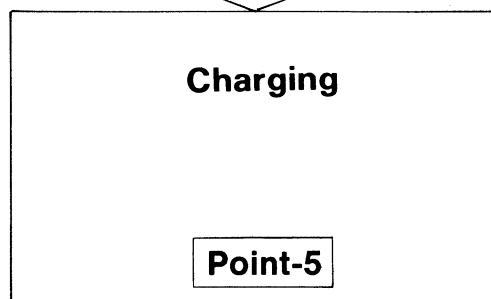

Charge the specified amount of refrigerant into system.

DISCHARGING, EVACUATING, CHARGING AND CHECKING

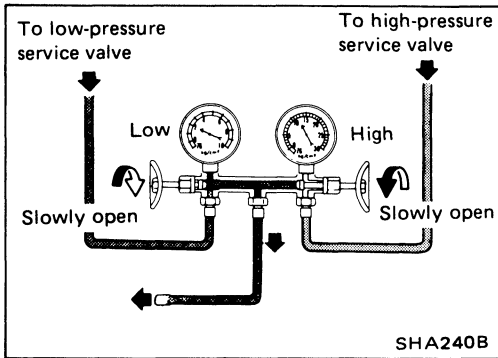

Discharging—Point-1

Slowly open the valves to discharge only refrigerant. If they are opened quickly, compressor oil will also be discharged.

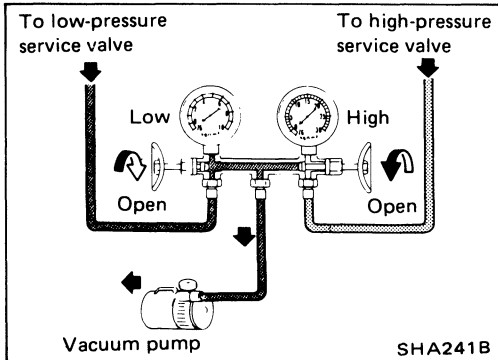

Evacuating the System—Point-2

1. Start pump, then open both valves and run pump for about 5 minutes.
2. When low gauge has reached approx. 101.3 kPa (760 mmHg, 29.92 inHg), completely close both valves of gauge and stop vacuum pump. Let it stand for 5 to 10 minutes in this state and confirm that the reading does not rise.
 - a. The low-pressure gauge reads lower by 3.3 kPa (25 mmHg, 0.98 inHg) per 300 m (1,000 ft) elevation. Perform evacuation according to the following table.
 - b. The rate of ascension of the low-pressure gauge should be less than 3.3 kPa (25 mmHg, 0.98 inHg) in 5 minutes.

Elevation m (ft)	Vacuum of system* kPa (mmHg, inHg)
0 (0)	101.3 (760, 29.92)
300 (1,000)	98.0 (735, 28.94)
600 (2,000)	94.6 (710, 27.95)
900 (3,000)	91.3 (685, 26.97)

*: Values show reading of the low-pressure gauge.

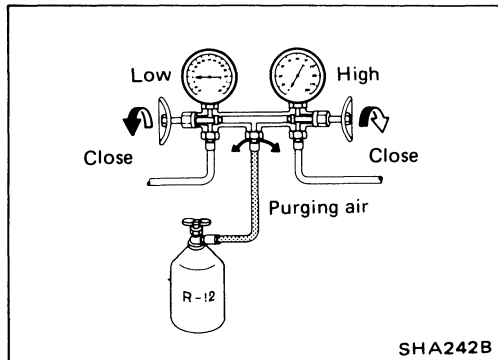

Charging—Point-3

1. Evacuate refrigerant system.
Refer to "Point-2".
2. Close manifold gauge valves securely and disconnect charging hose from vacuum pump.
3. Purge air from center charging hose.
 - 1) Connect center charging hose to refrigerant can through charge valve.
 - 2) Break seal of refrigerant can and purge air.

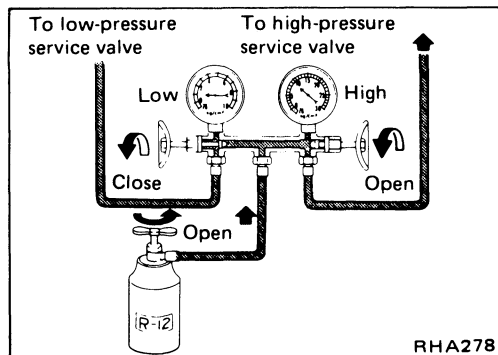

4. Charge refrigerant into system.

WARNING:

Ensure that engine is off.

- 1) Open high-pressure valve of manifold gauge and charge refrigerant into system.

DISCHARGING, EVACUATING, CHARGING AND CHECKING

Charging—Point-3 (Cont'd)

CAUTION:

If charging liquefied refrigerant into system with the can turned upside down to reduce charging time, charge it only through high-pressure (discharge) service valve. After charging, the compressor should always be turned several times manually.

- 2) When low-pressure gauge reading is 98 kPa (1.0 kg/cm², 14 psi), completely close high-pressure valve of manifold gauge and stop charging.

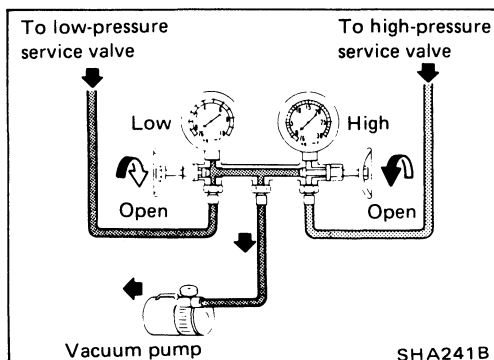
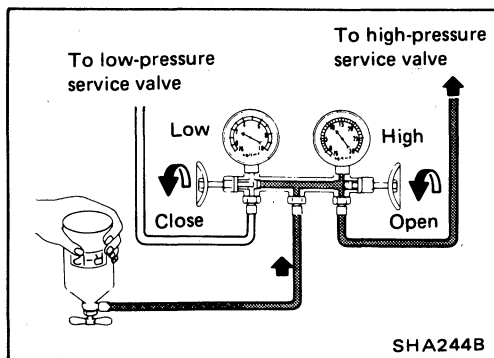

Evacuating the System—Point-4

1. Close manifold gauge valve securely and disconnect charging hose from refrigerant can.
2. Connect center charging hose to vacuum pump.
3. Start pump, then open both valves and run pump for about 20 minutes.

Charging—Point-5

1. Charge refrigerant into system.

Refer to “Point-3”.

WARNING:

Ensure that engine is off.

- 1) Open low-pressure valve of manifold gauge and charge refrigerant into system.
- 2) When refrigerant charging speed slows down, close high-pressure valve of manifold gauge and open low-pressure valve of manifold gauge and charge refrigerant while running the compressor for ease of charging.
- 3) Start engine — Air conditioning system ON, maximum temperature set, maximum blower speed. Open low-pressure valve on gauge set, with can in upright position, and monitor sight glass. Charge is complete when sight glass is clear.

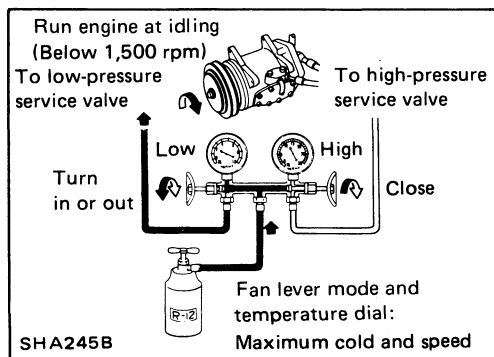

Charging—Point-5 (Cont'd)

Cycling clutch systems will produce bubbles in sight glass when clutch engages. Therefore, allow 5 seconds after clutch engages to determine if bubbles continue, and, if so, add refrigerant to clear sight glass.

WARNING:

Never charge refrigerant through high-pressure side (discharge side) of system since this will force refrigerant back into refrigerant can and can may explode.

4. Charge refrigerant while controlling low-pressure gauge reading at 275 kPa (2.8 kg/cm², 40 psi) or less by turning in or out low-pressure valve of manifold gauge.
- Be sure to purge air from charging hose when replacing can with a new one.

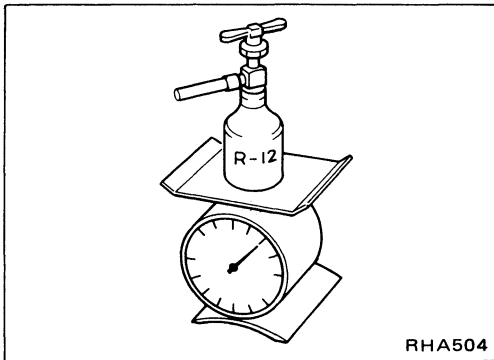

5. Charge the specified amount of refrigerant into system by weighing charged refrigerant with scale. Overcharging will cause discharge pressure to rise.

Refrigerant amount:

0.8 - 0.9 kg (1.8 - 2.0 lb)

The state of the bubbles in sight glass should only be used for checking whether the amount of charged refrigerant is small or not. The amount of charged refrigerant can be correctly judged by means of discharge pressure.

6. After charging, be sure to install valve cap on service valve.
7. Confirm that there are no leaks in system by checking with a leak detector.
- When refrigerant charging is performed with a charging cylinder, charging station, or automatic charging equipment, engine off, charge only through high side, after specified refrigerant amount has entered the system, close high pressure valve on gauge set. Start engine return to idle speed, operate A/C at maximum temperature setting, high blower. Observe sight glass to confirm complete charge.

Overcharging will result in increased high pressures, and reduced performance.

DISCHARGING, EVACUATING, CHARGING AND CHECKING

Checking Refrigerant Level

CONDITION

- Door window: Open
- A/C switch: ON
- TEMP. lever position: Max. COLD
- FAN lever position: 4
- Check sight glass after a lapse of about five minutes.

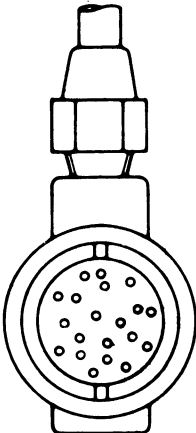
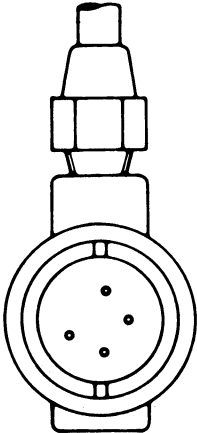
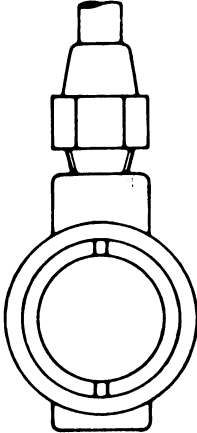
Amount of refrigerant	Almost no refrigerant	Insufficient	Suitable	Too much refrigerant
Check item				
Temperature of high-pressure and low-pressure lines.	Almost no difference between high-pressure and low-pressure side temperature.	High-pressure side is warm and low-pressure side is fairly cold.	High-pressure side is hot and low-pressure side is cold.	High-pressure side is abnormally hot.
State in sight glass.	Bubbles flow continuously. Bubbles will disappear and something like mist will flow when refrigerant is nearly gone.	The bubbles are seen at intervals of 1 - 2 seconds.	Almost transparent. Bubbles may appear when engine speed is raised and lowered. No clear difference exists between these two conditions.	No bubbles can be seen.
	 AC256	 AC257	 AC258	
Pressure of system.	High-pressure side is abnormally low.	Both pressures on high and low-pressure sides are slightly low.	Both pressures on high and low-pressure sides are normal.	Both pressures on high and low-pressure sides are abnormally high.
Repair.	Stop compressor immediately and conduct an overall check.	Check for gas leakage, repair as required, replenish and charge system.		Discharge refrigerant from service valve of low pressure side.

a. The bubbles seen through the sight glass are influenced by the ambient temperature. Since the bubbles are hard to show up in comparatively low temperatures below 20°C (68°F), it is possible that a slightly larger amount of refrigerant would be filled, if supplied according to the sight glass. Recheck the amount when it

exceeds 20°C (68°F). In higher temperature the bubbles are easy to show up.

b. When the screen in the receiver drier is clogged, the bubbles will appear even if the amount or refrigerant is normal. In this case, the outlet side pipe of the receiver drier becomes considerably cold.

DISCHARGING, EVACUATING, CHARGING AND CHECKING

Nominal sensitivity:
15 - 25 g (0.53 - 0.88 oz)/year

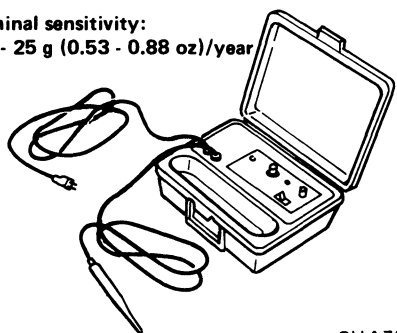

SHA733A

UNION TYPE

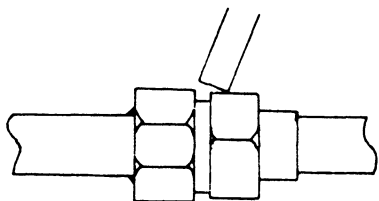

RHA279

PLATE TYPE

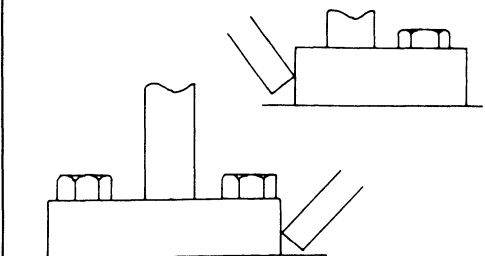

RHA280

Checking Refrigerant Leaks

ELECTRIC LEAK DETECTOR

The leak detector is a delicate device that detects small amounts of halogen.

To use the device properly, read the manufacturer's manuals. Also perform the specified maintenance and inspections.

GENERAL PRECAUTIONS FOR HANDLING LEAK DETECTOR

Place the probe on connection fitting and wait for 5 seconds or more.

To check cooling unit, wait for 10 seconds or more.

Keep the probe as still as possible for one more minute.

When testing single-bolt flange, place the probe on the opposite side of the fitting.

MEASUREMENT STANDARD

If any leak is noted with a detector having a nominal sensitivity of 15 to 25 g (0.53 to 0.88 oz)/year, that leak must be repaired.

- The nominal sensitivity of the detector is determined under the assumption that all the leaking gas is collected by the detector. Accordingly, the quantity of gas actually leaking can amount to five to ten times the indicated value. Generally speaking, leakage of 150 to 200 g (5.29 to 7.05 oz) of refrigerant can cause insufficient cooling.
- Oil deposited during assembling must be wiped off before inspection. Refrigerant easily dissolves in oil, and the presence of oil can cause an error in measurement. This precaution is important when checking a used car for refrigerant leakage.
- If oil is noted at or around connections, it indicates that refrigerant is leaking.

Refrigeration Cycle

REFRIGERANT FLOW

The refrigerant flows in the standard pattern, that is, through the compressor, the condenser, the receiver drier, through the evaporator, and back to the compressor.

The refrigerant evaporation through the evaporator coil is controlled by an externally equalized expansion valve, located inside the evaporator case.

FREEZE PROTECTION — Compressor control

The compressor cycles on and off to maintain the evaporator temperature within a specified range. When the evaporator coil temperature falls below a specified point, the thermo control amplifier interrupts the compressor operation. When the evaporator coil temperature rises above the specification, the thermo control amplifier allows compressor operation.

REFRIGERANT SYSTEM PROTECTION

The refrigerant system is protected against excessively high pressure by a fusible plug located on the receiver drier, and protection against excessively high or low pressure (interruption of compressor operation) is provided by a dual pressure switch located on the receiver drier.

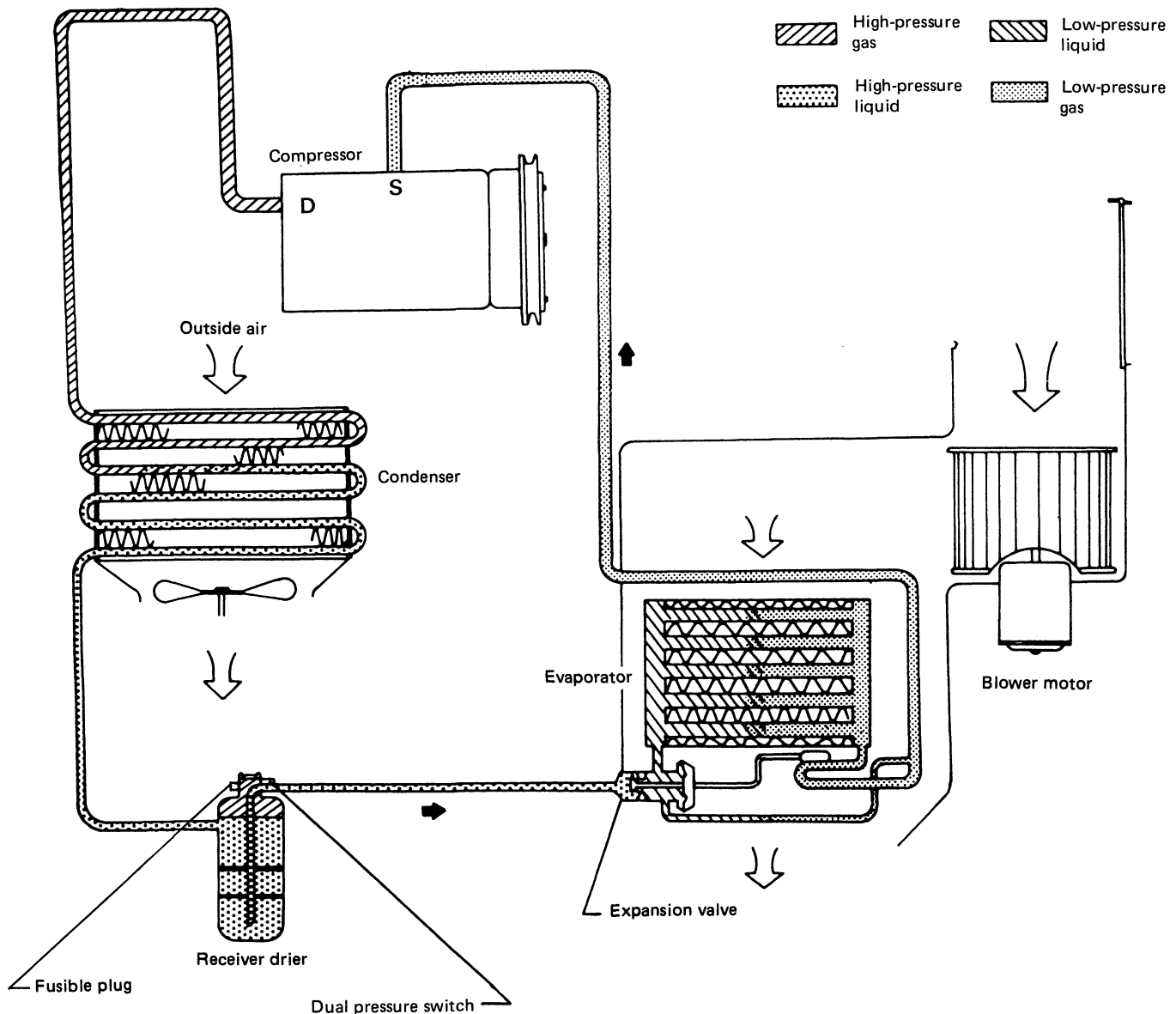

RHA321A

Refrigerant Lines

VG ENGINE MODEL

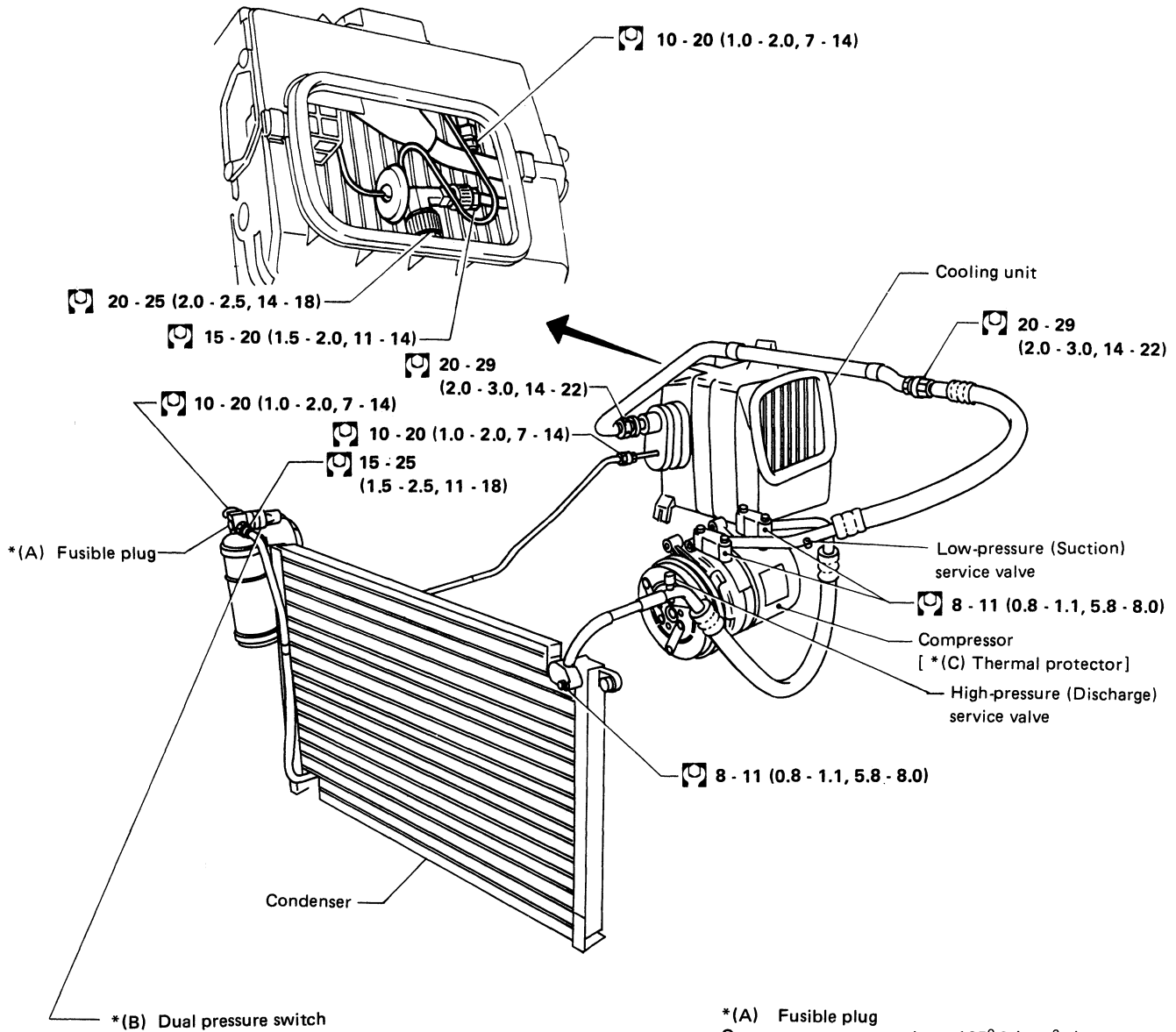

: N·m (kg·m, ft·lb)

*(C) Thermal protector

Temperature in compressor	°C (°F)	Operation
Increasing to approx.	145 - 155 (293 - 311)	Turns OFF
Decreasing to approx.	130 - 140 (266 - 284)	Turns ON

*(A) Fusible plug

Open at temperatures above 105°C (221°F), thereby discharging refrigerant to the atmosphere. If this plug is melted and opened, check the refrigerant line and replace receiver drier.

*(B) Dual pressure switches

- Low-pressure side
Turns OFF at pressures below 177 to 216 kPa (1.8 to 2.2 kg/cm², 26 to 31 psi), cutting compressor power supply, and turns ON at pressures above 177 to 235 kPa (1.8 to 2.4 kg/cm², 26 to 34 psi).
- High-pressure side
Turns OFF at pressures above 2,452 to 2,844 kPa (25 to 29 kg/cm², 356 to 412 psi), cutting compressor power supply, and turns ON at pressures below 1,373 to 1,667 kPa (14 to 17 kg/cm², 199 to 242 psi).

PIPING, COMPRESSOR MOUNTING AND F.I.C.D.

Refrigerant Lines (Cont'd)

Z ENGINE MODEL

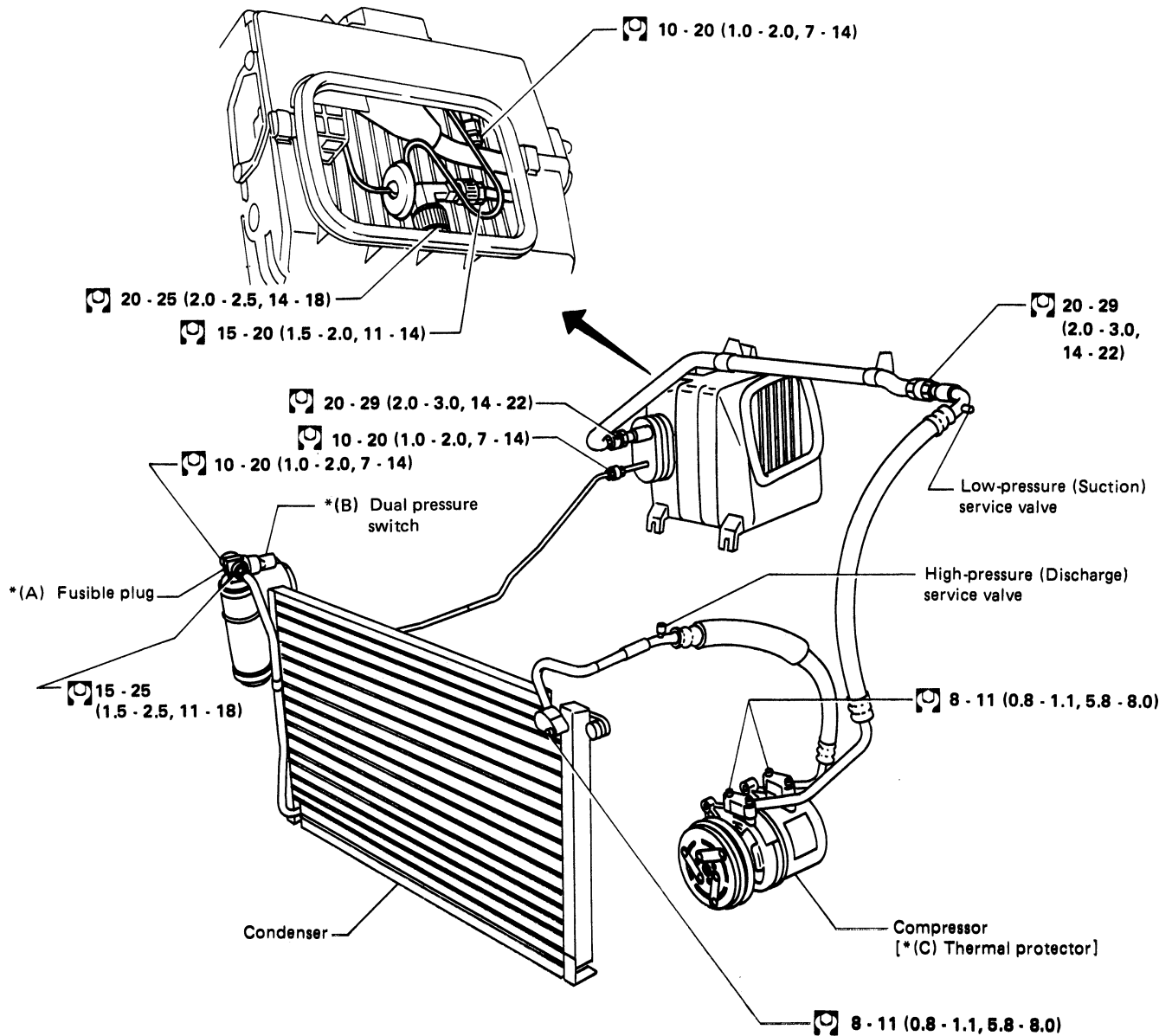

: N·m (kg-m, ft-lb)

* (C) Thermal protector

Temperature in compressor	°C (°F)	Operation
Increasing to approx.	145 - 155 (293 - 311)	Turns OFF
Decreasing to approx.	130 - 140 (266 - 284)	Turns ON

* (A) Fusible plug

Open at temperatures above 105°C (221°F), thereby discharging refrigerant to the atmosphere. If this plug is melted and opened, check the refrigerant line and replace receiver drier.

* (B) Dual pressure switches

- Low-pressure side
Turns OFF at pressures below 177 to 216 kPa (1.8 to 2.2 kg/cm², 26 to 31 psi), cutting compressor power supply, and turns ON at pressures above 177 to 235 kPa (1.8 to 2.4 kg/cm², 26 to 34 psi).
- High-pressure side
Turns OFF at pressures above 2,452 to 2,844 kPa (25 to 29 kg/cm², 356 to 412 psi), cutting compressor power supply, and turns ON at pressures below 1,373 to 1,667 kPa (14 to 17 kg/cm², 199 to 242 psi).

RHA376

Compressor Mounting

VG engine model

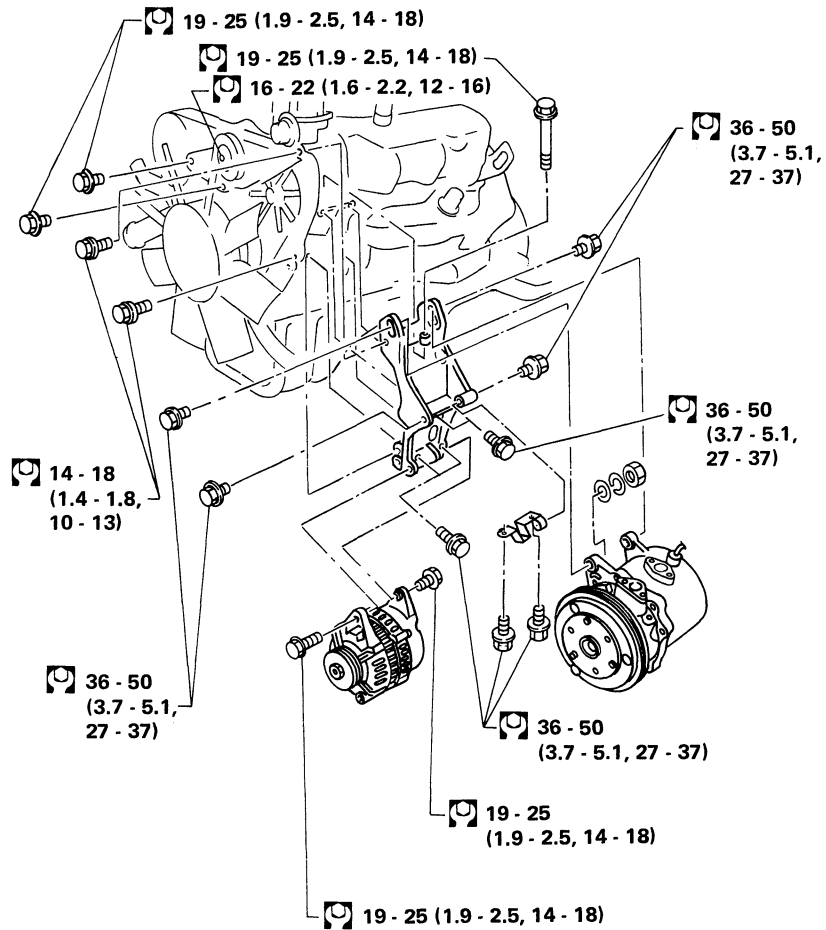

: N·m (kg·m, ft·lb)

RHA898

Z engine model

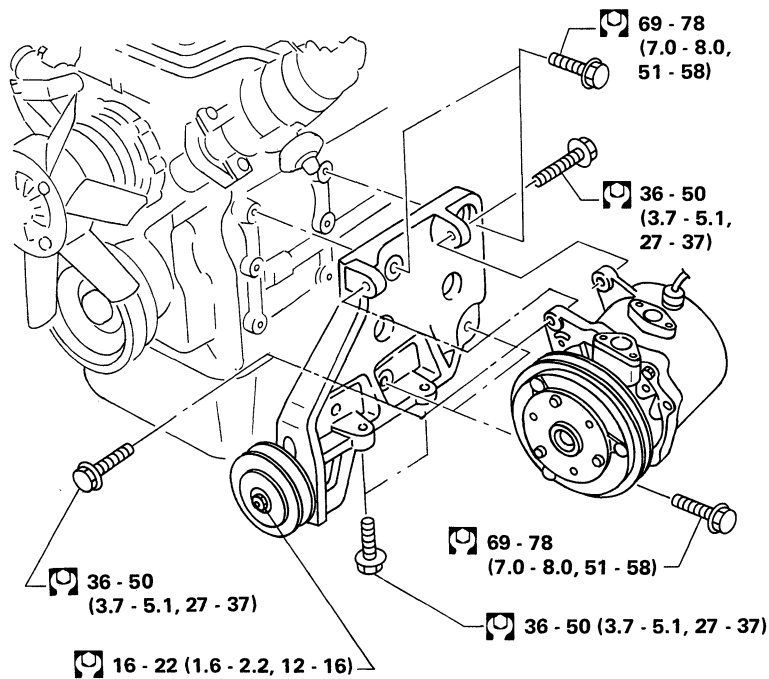

: N·m (kg·m, ft·lb)

RHA899

Idle Speed Adjusting

FAST IDLE CONTROL DEVICE (F.I.C.D.)

1. Warm up engine completely.
2. Make sure engine is at correct idling speed with air conditioner in OFF position.

Idling speed (Air conditioner: OFF):

Refer to S.D.S. (MA section).

3. Set engine speed with air conditioner in ON position (when F.I.C.D. is actuated) to following procedure.

Engine rpm

(Air conditioner: ON):

Unit: rpm

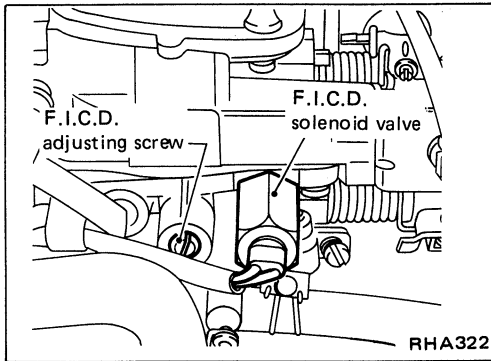



	Engine model	
	Transmission	VG30i
Manual	850 - 950	
Automatic (In "N" range)	850 - 950	

A/C PERFORMANCE TEST

Performance Chart

TEST CONDITION

Testing must be performed as follows:

Vehicle location:	Indoors or in the shade (in a well ventilated place)
Doors:	Closed
Door window:	Open
Hood:	Open
TEMP. lever position:	Max. COLD
Air control lever position:	 (Ventilation)
INTAKE lever position:	 (Recirculation)
FAN lever position:	4
Engine speed:	1,500 rpm
Time required before starting testing after air conditioner starts operating:	More than 10 minutes

TEST READING

VG engine model

Recirculating-to-discharge air temperature table

Inside air (Recirculating air) at blower assembly inlet		Discharge air temperature at center ventilator °C (°F)
Relative humidity %	Air temperature °C (°F)	
50 - 60	20 (68)	5.4 - 7.0 (42 - 45)
	25 (77)	9.4 - 11.6 (49 - 53)
	30 (86)	13.6 - 16.4 (56 - 62)
	35 (95)	17.8 - 21.0 (64 - 70)
60 - 70	20 (68)	7.0 - 9.0 (45 - 48)
	25 (77)	11.6 - 14.2 (53 - 58)
	30 (86)	16.4 - 19.4 (62 - 67)
	35 (95)	21.0 - 24.6 (70 - 76)

Ambient air temperature-to-compressor pressure table

Ambient air		High-pressure (Discharge side) kPa (kg/cm ² , psi)	Low-pressure (Suction side) kPa (kg/cm ² , psi)
Relative humidity %	Air temperature °C (°F)		
50 - 70	20 (68)	1,000 - 1,196 (10.2 - 12.2, 145 - 173)	88 - 137 (0.9 - 1.4, 13 - 20)
	25 (77)	1,216 - 1,451 (12.4 - 14.8, 176 - 210)	118 - 177 (1.2 - 1.8, 17 - 26)
	30 (86)	1,412 - 1,706 (14.4 - 17.4, 205 - 247)	157 - 216 (1.6 - 2.2, 23 - 31)
	35 (95)	1,618 - 1,961 (16.5 - 20.0, 235 - 284)	186 - 255 (1.9 - 2.6, 27 - 37)
	40 (104)	1,824 - 2,216 (18.6 - 22.6, 264 - 321)	226 - 294 (2.3 - 3.0, 33 - 43)

A/C PERFORMANCE TEST

Performance Chart (Cont'd)

Z engine model

Recirculating-to-discharge air temperature table

Inside air (Recirculating air) at blower assembly inlet		Discharge air temperature at center ventilator °C (°F)
Relative humidity %	Air temperature °C (°F)	
50 - 60	20 (68)	7.2 - 8.6 (45 - 47)
	25 (77)	11.0 - 12.8 (52 - 55)
	30 (86)	14.6 - 16.8 (58 - 62)
	35 (95)	18.4 - 21.0 (56 - 70)
60 - 70	20 (68)	8.6 - 10.4 (47 - 51)
	25 (77)	12.8 - 14.8 (55 - 59)
	30 (86)	16.8 - 19.2 (62 - 67)
	35 (95)	21.0 - 23.6 (70 - 74)

Ambient air temperature-to-compressor pressure table

Ambient air		High-pressure (Discharge side) kPa (kg/cm ² , psi)	Low-pressure (Suction side) kPa (kg/cm ² , psi)
Relative humidity %	Air temperature °C (°F)		
50 - 70	20 (68)	941 - 1,157 (9.6 - 11.8, 137 - 168)	118 - 167 (1.2 - 1.7, 17 - 24)
	25 (77)	1,118 - 1,353 (11.4 - 13.8, 162 - 196)	137 - 196 (1.4 - 2.0, 20 - 28)
	30 (86)	1,295 - 1,569 (13.2 - 16.0, 188 - 228)	157 - 226 (1.6 - 2.3, 23 - 33)
	35 (95)	1,471 - 1,795 (15.0 - 18.3, 213 - 260)	186 - 255 (1.9 - 2.6, 27 - 37)
	40 (104)	1,628 - 2,001 (16.6 - 20.4, 236 - 290)	216 - 284 (2.2 - 2.9, 31 - 41)

Checking and Adjusting

The oil used to lubricate the compressor is circulating with the refrigerant.

Whenever replacing any component of the system or a large amount of gas leakage occurs, add oil to maintain the original amount of oil.

OIL CAPACITY

Unit: mℓ (US fl oz, Imp fl oz)

Applied model	All models
Capacity	
Total in system	200 (6.8, 7.0)
Amount of oil which can be drained	70 - 120 (2.4 - 4.1, 2.5 - 4.2)*
Compressor (Service parts) charging amount	200 (6.8, 7.0)

*: All oil cannot be drained from system.

OIL RETURN OPERATION

Before checking and adjusting oil level, operate compressor at engine idling speed, with controls set for maximum cooling and high blower speed, for 20 to 30 minutes in order to return oil to compressor.

CHECKING AND ADJUSTING FOR USED COMPRESSOR

1. After oil return operation, stop the engine and discharge refrigerant and then remove compressor from the vehicle.
2. Drain compressor oil from compressor discharge port and measure the amount.

Oil is sometimes hard to extract when compressor is cooled. Remove oil while compressor is warm [maintained to 40 to 50°C (104 to 122°F)].

3. If the amount is less than 70 mℓ (2.4 US fl oz, 2.5 Imp fl oz), some refrigerant may have leaked out. Conduct leak tests on connections of each system, and if necessary, repair or replace faulty parts.

4. Check the purity of the oil and then adjust oil level following the procedure below.

- (a) When oil is clean;

Unit: mℓ (US fl oz, Imp fl oz)

Amount of oil drained	Adjusting procedure
Above 70 (2.4, 2.5)*	Oil level is right. Pour in same amount of oil as was drained out.
Below 70 (2.4, 2.5)	Oil level may be low. Pour in 70 mℓ (2.4 US fl oz, 2.5 Imp fl oz) of oil.

*: If amount of oil drained is much greater than under normal circumstances, flush air conditioner system with refrigerant. Then pour in 200 mℓ (6.8 US fl oz, 7.0 Imp fl oz) of oil into air conditioner system.

- (b) When oil contains chips or other foreign material;

After air conditioner system has been flushed with refrigerant, replace receiver drier. Then pour in 200 mℓ (6.8 US fl oz, 7.0 Imp fl oz) of oil into air conditioner system.

CHECKING AND ADJUSTING FOR COMPRESSOR REPLACEMENT

200 mℓ (6.8 US fl oz, 7.0 Imp fl oz) of oil is charged in compressor (service parts). So it is necessary to drain the proper amount of oil from new compressor. Follow the procedure below.

1. After oil return operation, drain compressor oil from used compressor and measure the amount.

(It is the same procedure as CHECKING AND ADJUSTING FOR USED COMPRESSOR.)

Checking and Adjusting (Cont'd)

2. Check the purity of the oil and then adjust oil level following the procedure below.

(a) When oil is clean;

Unit: ml (US fl oz, Imp fl oz)

Amount of oil drained from used compressor	Draining amount of oil from new compressor
Above 70 (2.4, 2.5)*	200 (6.8, 7.0) – [Amount of oil drained + 20 (0.7, 0.7)]
Below 70 (2.4, 2.5)	110 (3.7, 3.9)

*: If amount of oil drained is greater than under normal circumstances, flush air conditioner system with refrigerant. Then install new compressor [200 ml (6.9 US fl oz, 7.0 Imp fl oz) of oil is charged in compressor service parts.]

Example: Unit: ml (US fl oz, Imp fl oz)

Amount of oil drained from used compressor	Draining amount of oil from new compressor
90 (3.0, 3.2)	90 (3.0, 3.2)
50 (1.7, 1.8)	110 (3.7, 3.9)

- (b) When oil contains chips or foreign material;
 After air conditioner system has been flushed with refrigerant, replace receiver drier. Then install new compressor [200 ml (6.8 US fl oz, 7.0 Imp fl oz) of oil is charged in compressor service parts.]

Precautions

- Plug all openings to prevent moisture and foreign matter from entering.
- Do not leave compressor on its side or upside down for more than 10 minutes.
- When replacing or repairing compressor, check compressor oil level in system.
- When replacing with a new compressor, drain specified oil from new compressor. Refer to **COMPRESSOR OIL**.
- Be sure there is no oil or dirt on frictional surface of clutch disc and pulley.
- When replacing compressor clutch, be careful not to scratch shaft or bend pulley.
- When replacing compressor clutch assembly, do not forget **BREAK-IN OPERATION**.
- When storing a compressor, be sure to fill it with refrigerant to prevent rust formation. Add refrigerant at the low-pressure side and purge air at the high-pressure side, while rotating shaft by hand.

COMPRESSOR — Model DKV-14C (DIESEL-KIKI make)

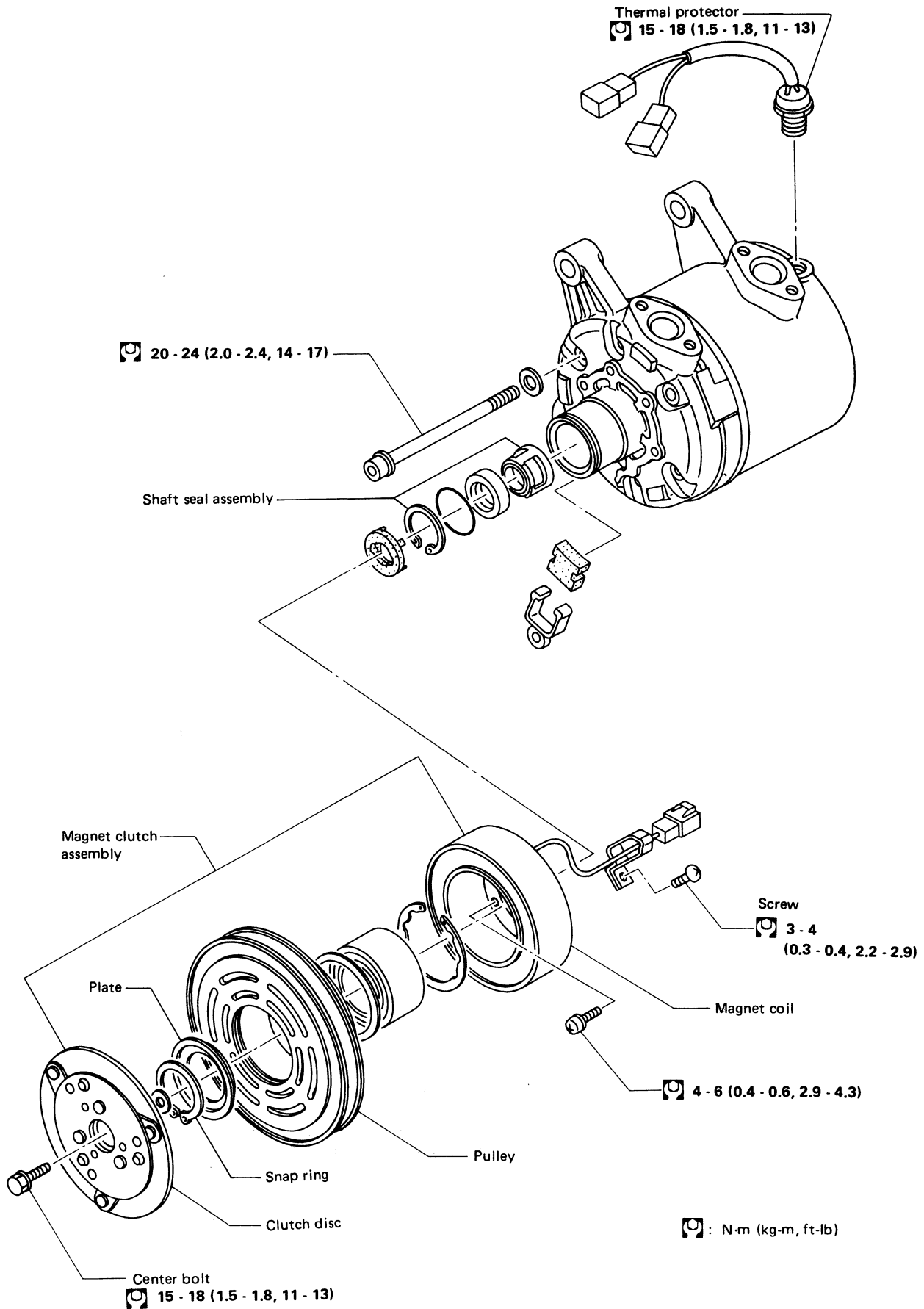

RHA402

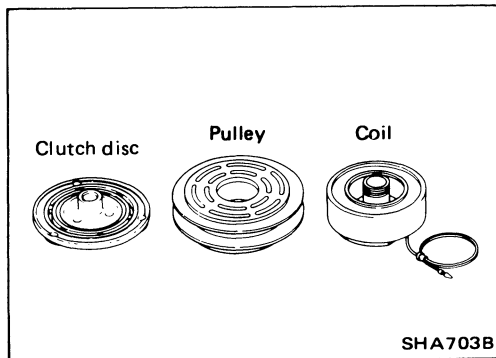
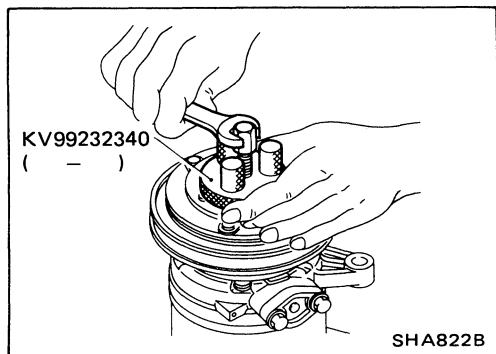
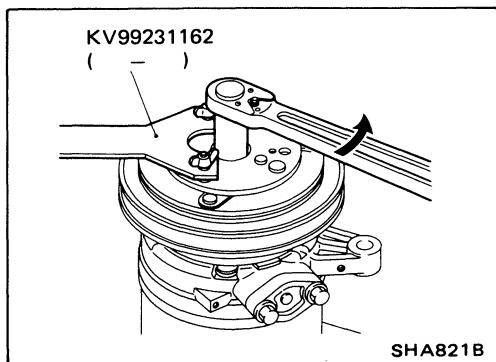

Compressor Clutch

REMOVAL

- When removing center bolt, hold clutch disc with clutch disc wrench.
- Using clutch disc puller clutch disc can be removed easily.

INSPECTION

Clutch disc

If the contact surface shows signs of damage due to excessive heat, the clutch disc and pulley should be replaced.

Pulley

Check the appearance of the pulley assembly. If the contact surface of the pulley shows signs of excessive grooving due to slippage, both the pulley and clutch disc should be replaced. The contact surfaces of the pulley assembly should be cleaned with a suitable solvent before reinstallation.

Coil

Check coil for loose connection or cracked insulation.

INSTALLATION

- Position coil assembly on compressor body. Be sure that the electrical terminals are reassembled in the original position. Install and tighten coil mounting screws evenly.

COMPRESSOR — Model DKV-14C (DIESEL-KIKI make)

Compressor Clutch (Cont'd)

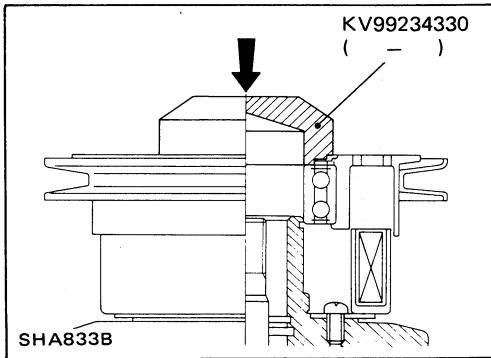

- Press pulley assembly onto the neck of coil assembly using pulley installer.
- Wipe oil thoroughly off the clutch surface.

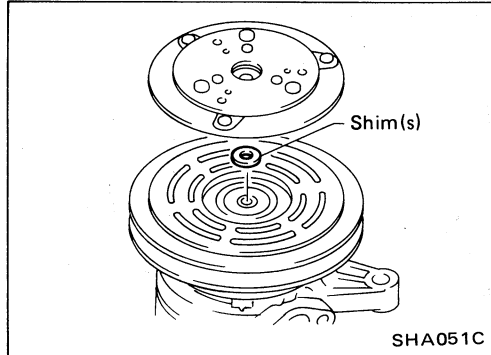

ADJUSTMENT

- Select adjusting shim(s) which give(s) the correct clearance between pulley and clutch disc.
- Using a plastic mallet, tap clutch disc in place on drive shaft.
- Do not use excessive force with a plastic mallet or in a press, or internal damages may result.
- Place spring washer and center bolt onto drive shaft. Tighten center bolt to drive clutch wheel onto drive shaft.

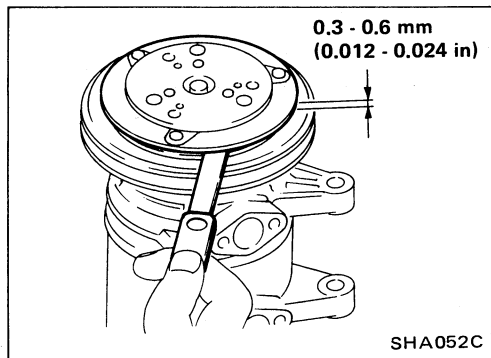

- Check clearance around the entire periphery of clutch disc.
Disc-to-pulley clearance:

0.3 - 0.6 mm (0.012 - 0.024 in)

If the specified clearance is not obtained, replace adjusting spacer and readjust.

BREAK-IN OPERATION

When replacing compressor clutch assembly, do not forget break-in operation, accomplished by engaging and disengaging the clutch some thirty times. Break-in operation raises the level of transmitted torque.

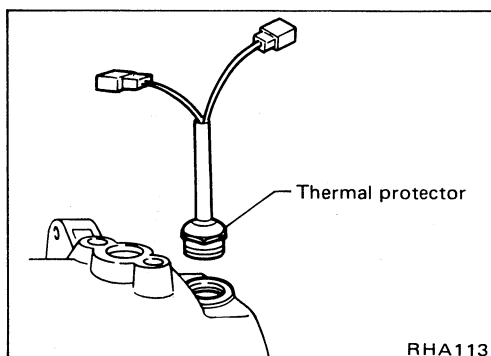

Thermal Protector

INSPECTION

- When servicing, do not allow foreign matter to get into compressor.
- Check continuity between two terminals.

A/C ELECTRICAL CIRCUIT

Schematic

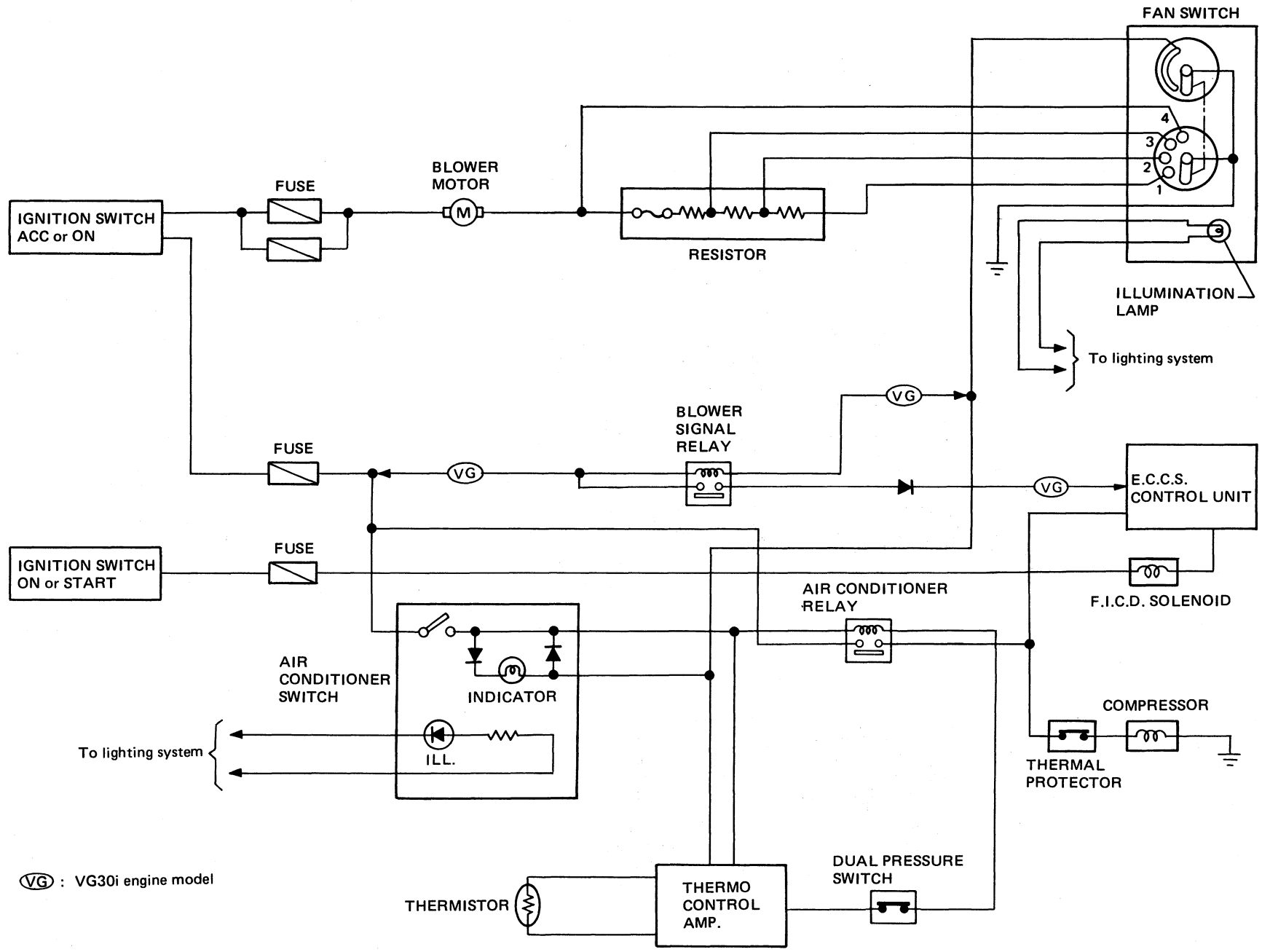

Ⓞ VG : VG30i engine model

HA-30

RHA322A

HA-31

RHA323A

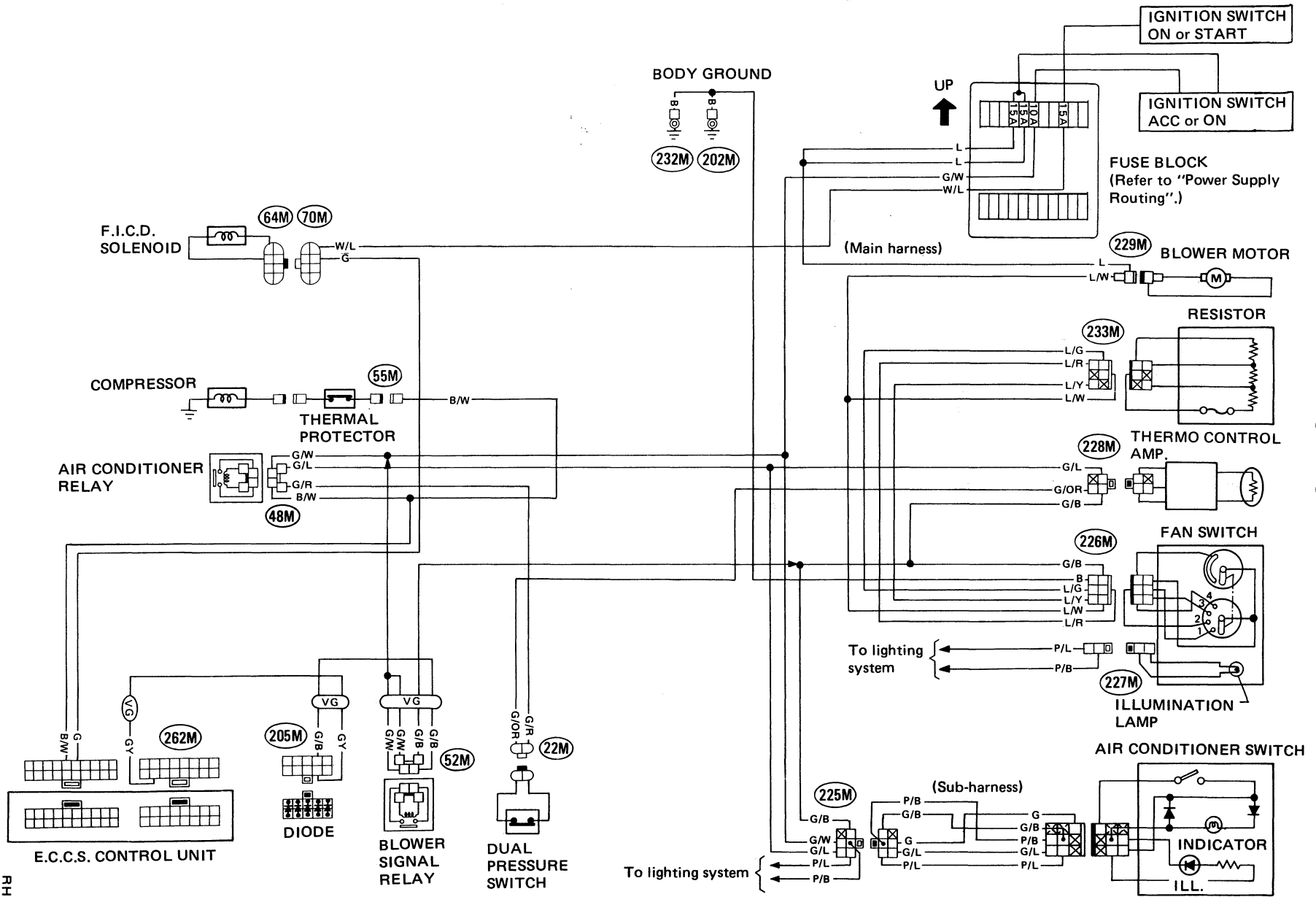

VG : VG30i engine model

Wiring Diagram

A/C ELECTRICAL CIRCUIT

A/C ELECTRICAL COMPONENTS

Inspection FAN SWITCH

Refer to page HA-6.

A/C SWITCH

Check circuit continuity with A/C switch ON as follows.

Indicator lamp

Illumination lamp

DISCONNECT

T.S.

Continuity exists: O.K. Continuity exists: O.K.

Continuity exists: O.K. Continuity does not exist: O.K.

RHA350A

THERMO CONTROL AMP.

THERMO CONTROL AMP.

Dual pressure switch

From A/C switch

From dual pressure switch

Evaporator outlet air temperature °C (°F)	Thermo amp. operation	Tester
Decreasing to 0.1 - 0.9 (32 - 34)	Turn OFF	Approx. 12 V
Increasing to 2.5 - 3.5 (37 - 38)	Turn ON	Approx. 0 V

H.S. CONNECT

RHA351A

A/C COMPONENT LAYOUT

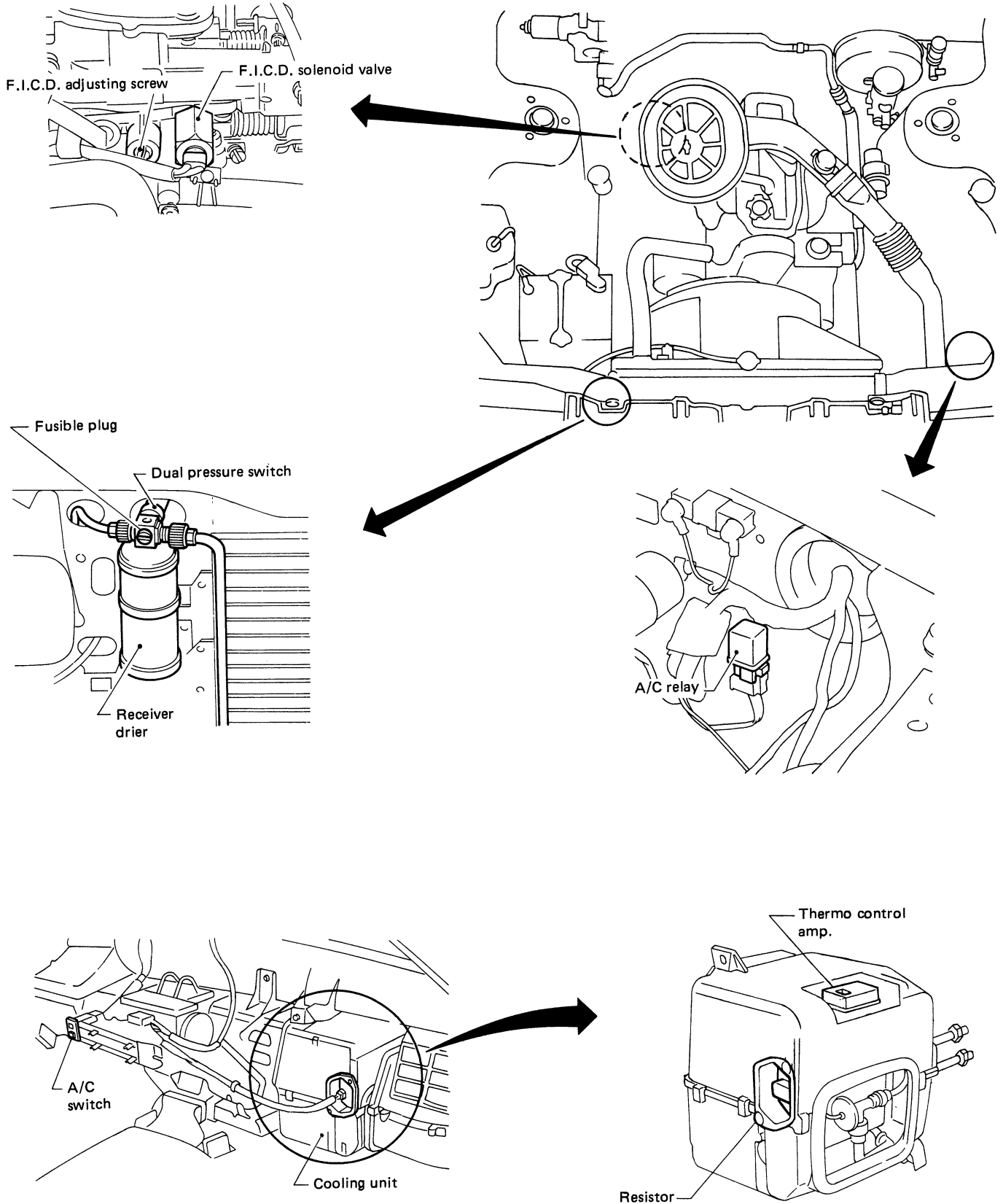

SERVICE DATA AND SPECIFICATIONS (S.D.S.)

General Specifications

COMPRESSOR

Model	DKV-14C
Type	Vane rotary
Displacement	cm ³ (cu in)/Rev 140 (8.54)
Direction of rotation	Clockwise (Viewed from drive end)
Drive belt	A type

LUBRICATION OIL

Model	DIESEL-KIKI make DKV-14C
Type	SUNISO 5GS
Capacity	mℓ (US fl oz, Imp fl oz) Total in system 200 (6.8, 7.0)
Amount of oil which can be drained	70 - 120 (2.4 - 4.1, 2.5 - 4.2)
Compressor (Service parts) charging amount	200 (6.8, 7.0)

REFRIGERANT

Type	R-12
Capacity	kg (lb) 0.8 - 0.9 (1.8 - 2.0)

Inspection and Adjustment

ENGINE IDLING SPEED

When A/C is ON (F.I.C.D. is actuated)

Unit: rpm

Transmission	Engine model	
	VG30i	Z24i
Manual	850 - 950	
Automatic (In "N" range)	850 - 950	

COMPRESSOR

Model	DKV-14C
Clutch disc-to-pulley clearance	0.3 - 0.6 mm (in) (0.012 - 0.024)

BELT TENSION

Refer to Checking Drive Belts (MA section).

SERVICE DATA AND SPECIFICATIONS (S.D.S.)

Tightening Torque

COMPRESSOR INSTALLATION

	VG engine model			Z engine model		
	N·m	kg-m	ft-lb	N·m	kg-m	ft-lb
Compressor bracket to cylinder block	36 - 50	3.7 - 5.1	27 - 37	69 - 78	7.0 - 8.0	51 - 58
Compressor to compressor bracket	36 - 50	3.7 - 5.1	27 - 37	36 - 50	3.7 - 5.1	27 - 37
Idler pulley bracket to compressor bracket	19 - 25	1.9 - 2.5	14 - 18	—	—	—

COMPRESSOR

Model	DKV-14C		
	N·m	kg-m	ft-lb
Center bolt	15 - 18	1.5 - 1.8	11 - 13
Thermal protector	15 - 18	1.5 - 1.8	11 - 13
Coil mounting screw	4 - 6	0.4 - 0.6	2.9 - 4.3

REFRIGERANT LINE

When connecting lines made of different material, basically use the lower tightening torque of the two.

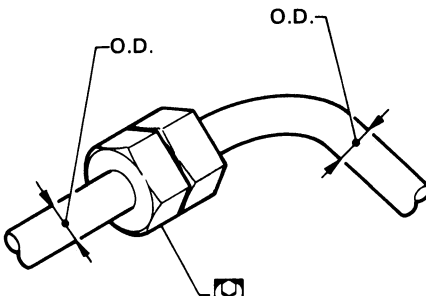
Union type (pipe to pipe)	Pipe O.D. mm (in)	Material					
		Steel or copper			Aluminum		
		N·m	kg-m	ft-lb	N·m	kg-m	ft-lb
 <p>SHA669A</p>	6 (1/4)	10 - 20	1.0 - 2.0	7 - 14	—	—	—
	8 (5/16)	15 - 25	1.5 - 2.5	11 - 18	10 - 20	1.0 - 2.0	7 - 14
	10 (3/8)	15 - 25	1.5 - 2.5	11 - 18	10 - 20	1.0 - 2.0	7 - 14
	12 (1/2)	20 - 29	2.0 - 3.0	14 - 22	15 - 25	1.5 - 2.5	11 - 18
	16 (5/8)	25 - 34	2.5 - 3.5	18 - 25	20 - 29	2.0 - 3.0	14 - 22
	19 (3/4)	25 - 34	2.5 - 3.5	18 - 25	20 - 29	2.0 - 3.0	14 - 22

SERVICE DATA AND SPECIFICATIONS (S.D.S.)

Tightening Torque (Cont'd)

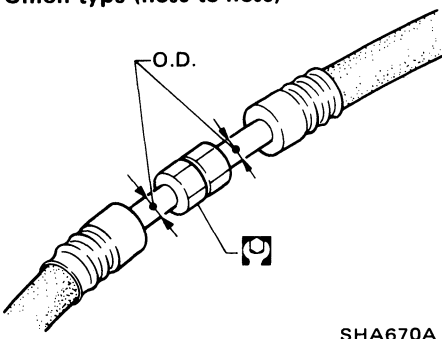
Union type (hose to hose)	Pipe O.D. mm (in)	Material					
		Steel or copper			Aluminum		
		N·m	kg-m	ft-lb	N·m	kg-m	ft-lb
 SHA670A	6 (1/4)	10 - 20	1.0 - 2.0	7 - 14	—	—	—
	8 (5/16)	15 - 25	1.5 - 2.5	11 - 18	10 - 20	1.0 - 2.0	7 - 14
	10 (3/8)	15 - 25	1.5 - 2.5	11 - 18	10 - 20	1.0 - 2.0	7 - 14
	12 (1/2)	25 - 34	2.5 - 3.5	18 - 25	20 - 29	2.0 - 3.0	14 - 22
	16 (5/8)	25 - 34	2.5 - 3.5	18 - 25	20 - 29	2.0 - 3.0	14 - 22

Union type (hose to pipe)	
 SHA671A	<ul style="list-style-type: none"> Use tightening torque for flexible hose.

Plate type	Bolt type				Tightening torque		
	Grade	Nominal size	Bolt diameter mm	Pitch mm	N·m	kg-m	ft-lb
 SHA672A		M6	6.0	1.0	3 - 4	0.3 - 0.4	2.2 - 2.9
	4T	M8	8.0	1.25	8 - 11	0.8 - 1.1	5.8 - 8.0
		M10	10.0	1.5	16 - 22	1.6 - 2.2	12 - 16
7T	M6	6.0	1.0	6 - 7	0.6 - 0.7	4.3 - 5.1	
	M8	8.0	1.25	14 - 18	1.4 - 1.8	10 - 13	
	M10	10.0	1.5	25 - 35	2.6 - 3.6	19 - 26	

ELECTRICAL SYSTEM

SECTION **EL**

When you read wiring diagrams:

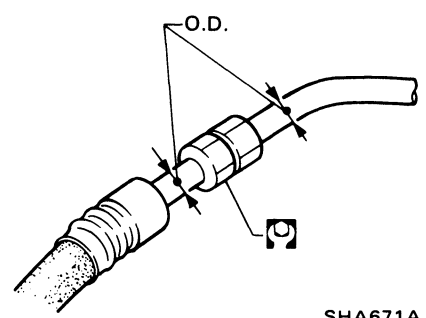
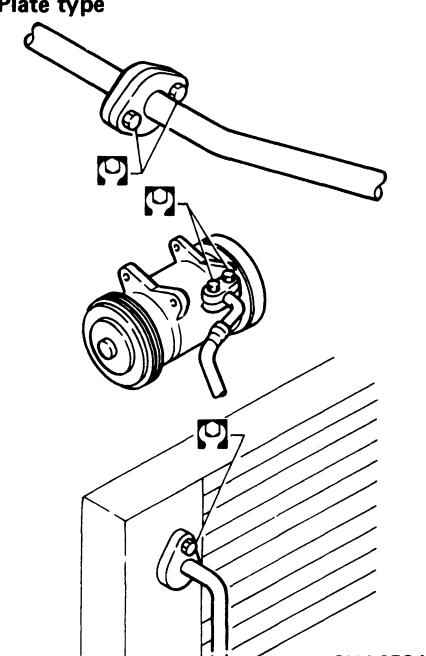
- Read GI section, "HOW TO READ WIRING DIAGRAMS".

CONTENTS

HARNESS CONNECTOR	EL- 2
STANDARDIZED RELAY	EL- 3
POWER SUPPLY ROUTING	EL- 5
BATTERY	EL- 7
STARTING SYSTEM	EL- 15
STARTING SYSTEM – Starter –	EL- 19
CHARGING SYSTEM	EL- 30
CHARGING SYSTEM – Alternator –	EL- 32
COMBINATION SWITCH	EL- 38
HEADLAMP	EL- 40
EXTERIOR LAMP	EL- 43
INTERIOR LAMP	EL- 50
METER AND GAUGES	EL- 54
WARNING LAMPS AND CHIME	EL- 61
WIPER AND WASHER	EL- 69
HORN, CIGARETTE LIGHTER, CLOCK	EL- 73
REAR WINDOW DEFOGGER	EL- 74
AUDIO	EL- 78
AUTOMATIC SPEED CONTROL DEVICE (A.S.C.D.)	EL- 81
LOCATION OF ELECTRICAL UNITS	EL- 89
HARNESS LAYOUT	EL- 93
SPECIAL SERVICE TOOL	EL-104
SUPER MULTIPLE JUNCTION (S.M.J.)	EL-105

WIRING DIAGRAM REFERENCE CHART

E.C.C.S.	EF & EC SECTION
LOCK-UP CONTROL SYSTEM	AT SECTION
ADJUSTABLE SHOCK ABSORBER ...	FA SECTION
POWER WINDOW	BF SECTION
POWER DOOR LOCK	BF SECTION
BACK DOOR WINDOW OPENER	BF SECTION
DOOR MIRROR	BF SECTION
HEATER AND AIR CONDITIONER ...	HA SECTION



HARNESS CONNECTOR

Description

HARNESS CONNECTOR

- All harness connectors prevent accidental looseness or disconnection.
- The connector can be disconnected by pushing or lifting the locking section.

CAUTION:

Do not pull the harness when disconnecting the connector.

[Example]

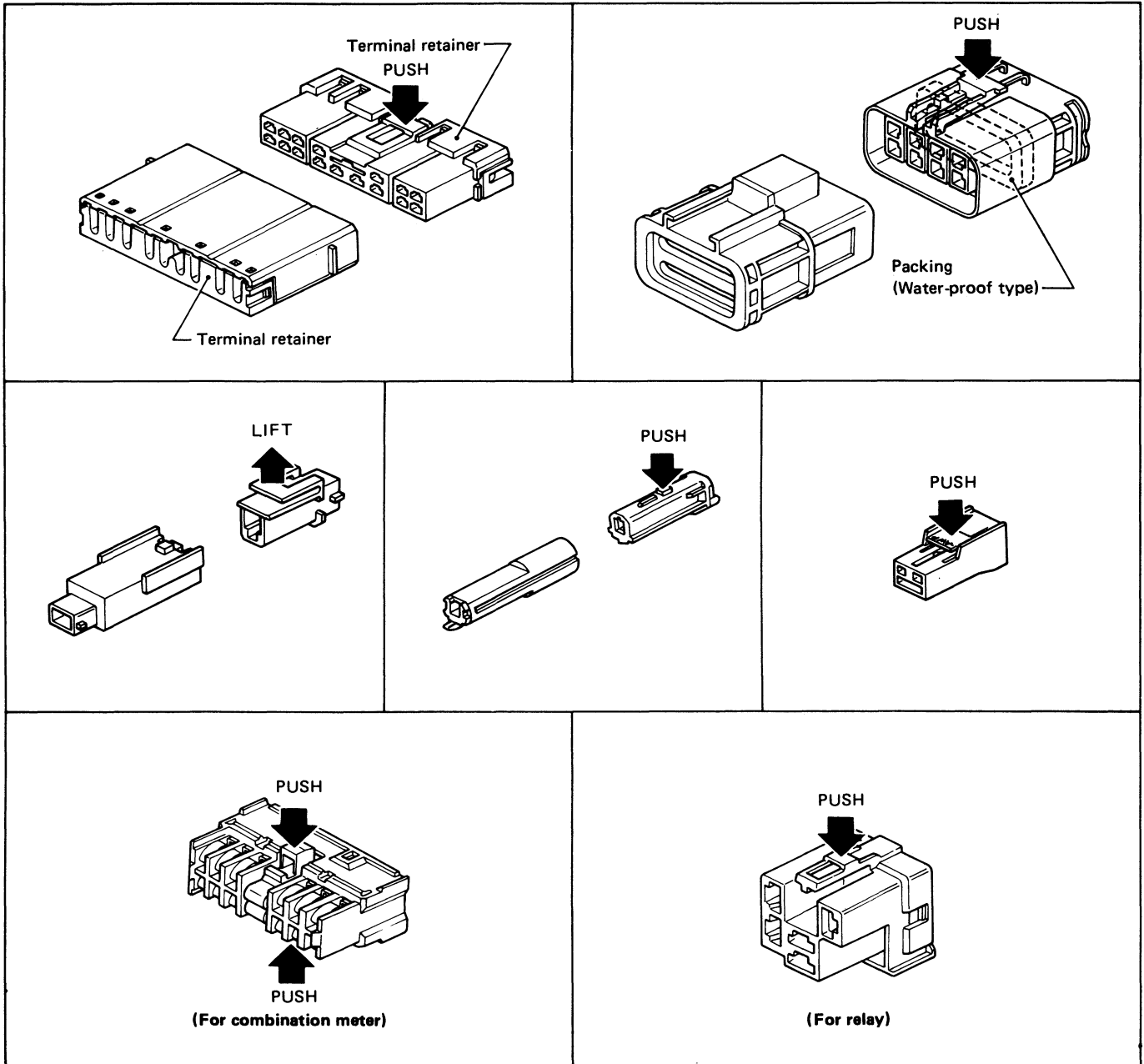

SEL769D

STANDARDIZED RELAY

Normal Open, Normal Closed and Mixed Type Relays

Relays can mainly be divided into three types: normal open, normal closed and mixed type relays.

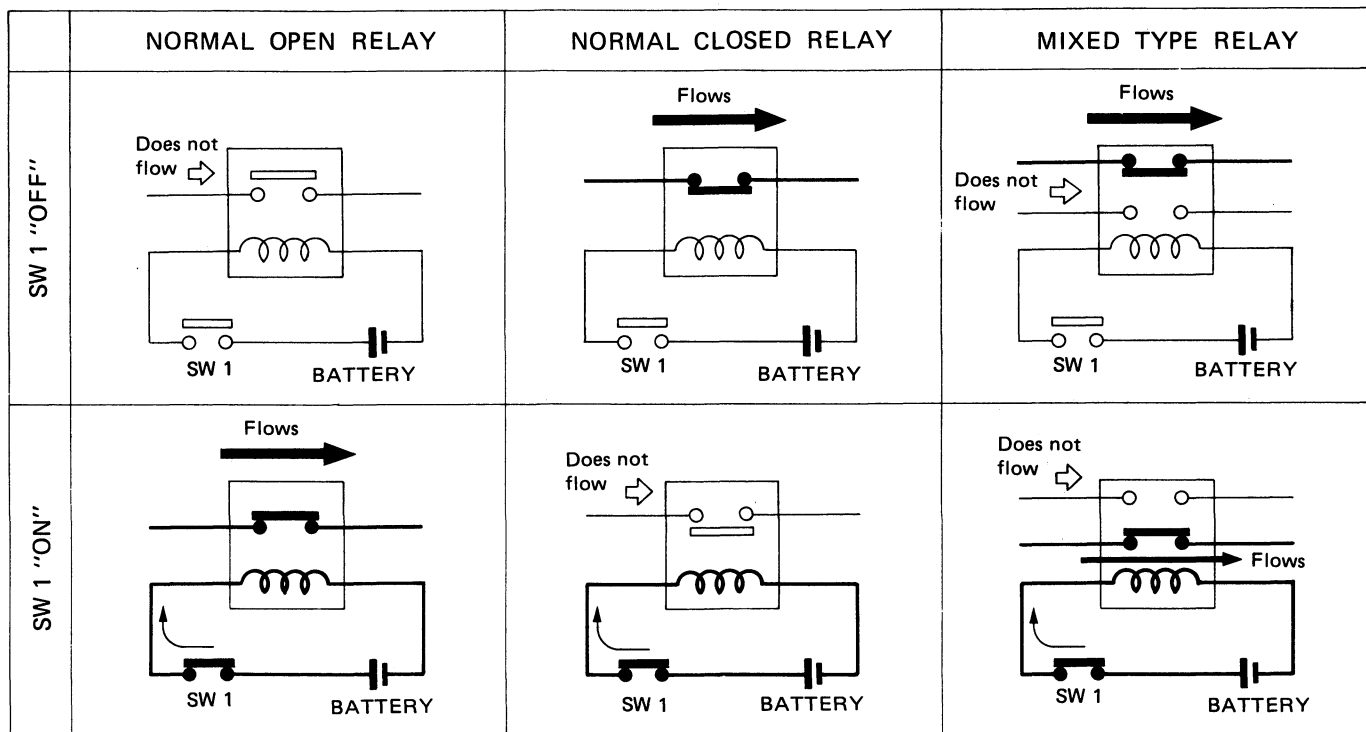

SEL881H

Type of Standardized Relays

1M 1 Make 2M 2 Make
 1T 1 Transfer 1M·1B 1 Make 1 Break

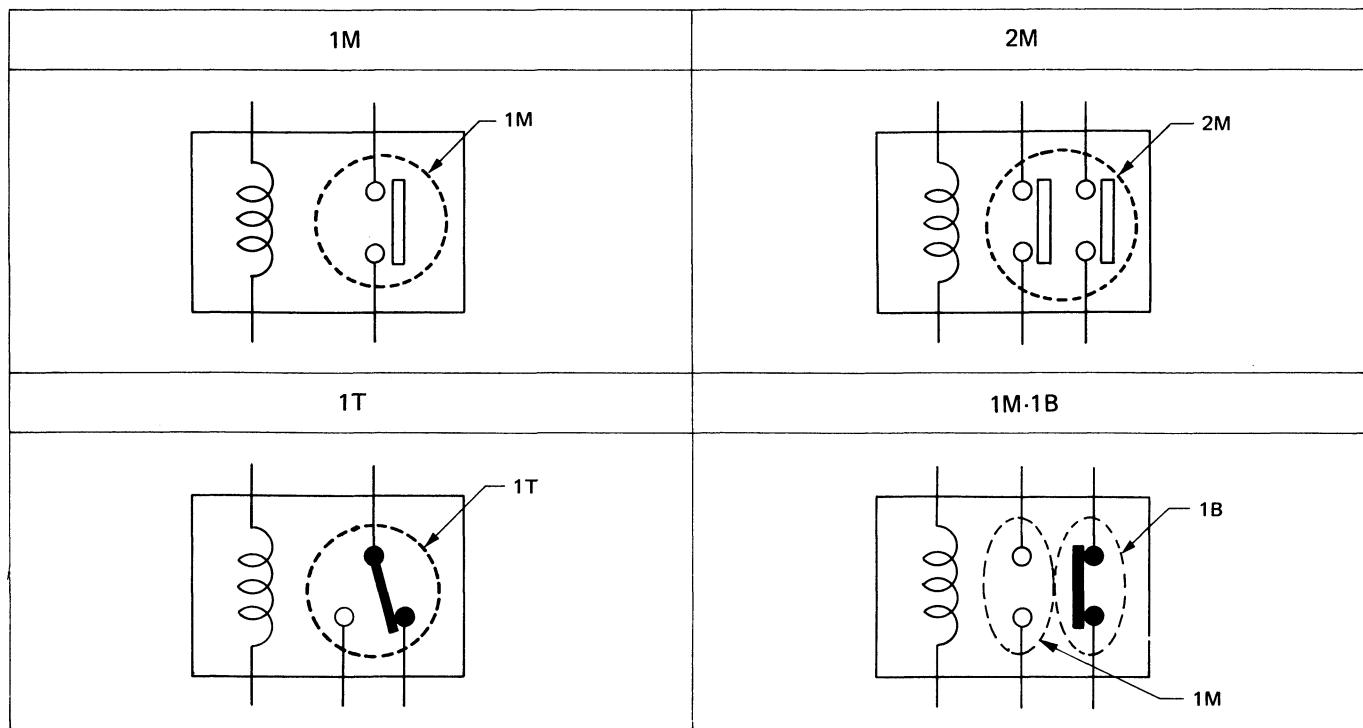

SEL882H

STANDARDIZED RELAY

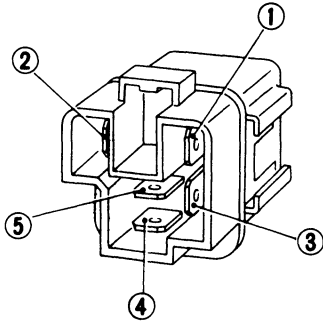
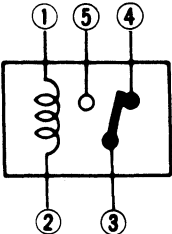
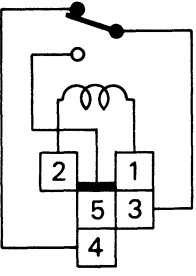
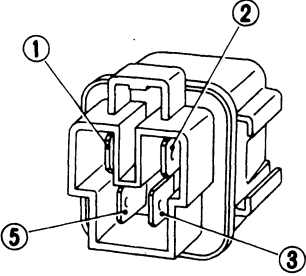
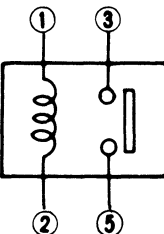
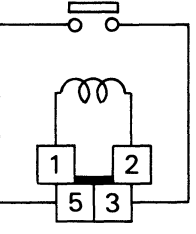
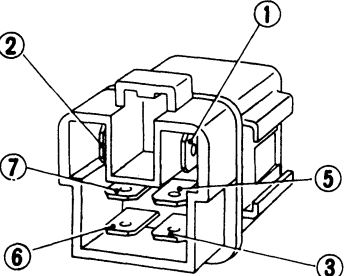
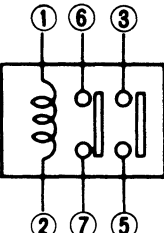
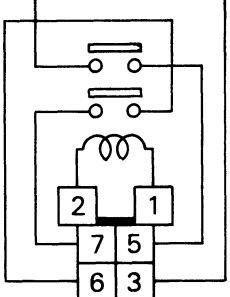
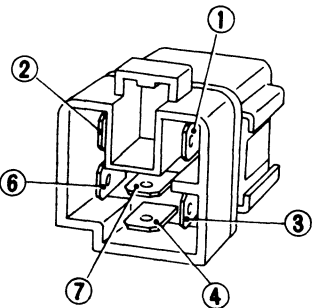
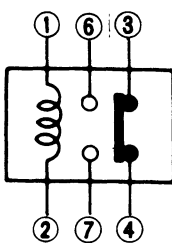
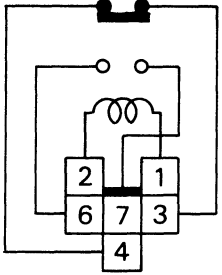
Type	Outer view	Circuit	Connector symbol and connection	Case color
1T				BLACK
1M				BLUE
2M				BROWN
1M-1B				GRAY

SEL883H

POWER SUPPLY ROUTING

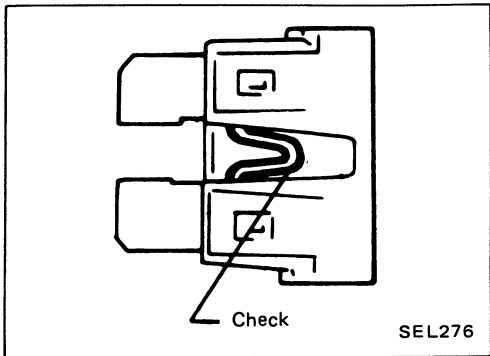

Fuse

- If fuse is blown, be sure to eliminate cause of problem before installing new fuse.
- Use fuse of specified rating. Never use fuse of more than specified rating.
- Do not install fuse in oblique direction; always insert it into fuse holder properly.
- Remove fuse for clock if vehicle is not used for a long period of time.

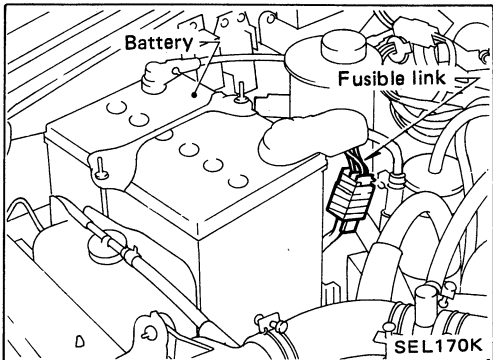

Fusible Link

A melted fusible link can be detected either by visual inspection or by feeling with finger tip. If its condition is questionable, use circuit tester or test lamp.

CAUTION:

- If fusible link should melt, it is possible that critical circuit (power supply or large current carrying circuit) is shorted. In such a case, carefully check and eliminate cause of problem.
- Never wrap periphery of fusible link with vinyl tape. Extreme care should be taken with this link to ensure that it does not come into contact with any other wiring harness or vinyl or rubber parts.

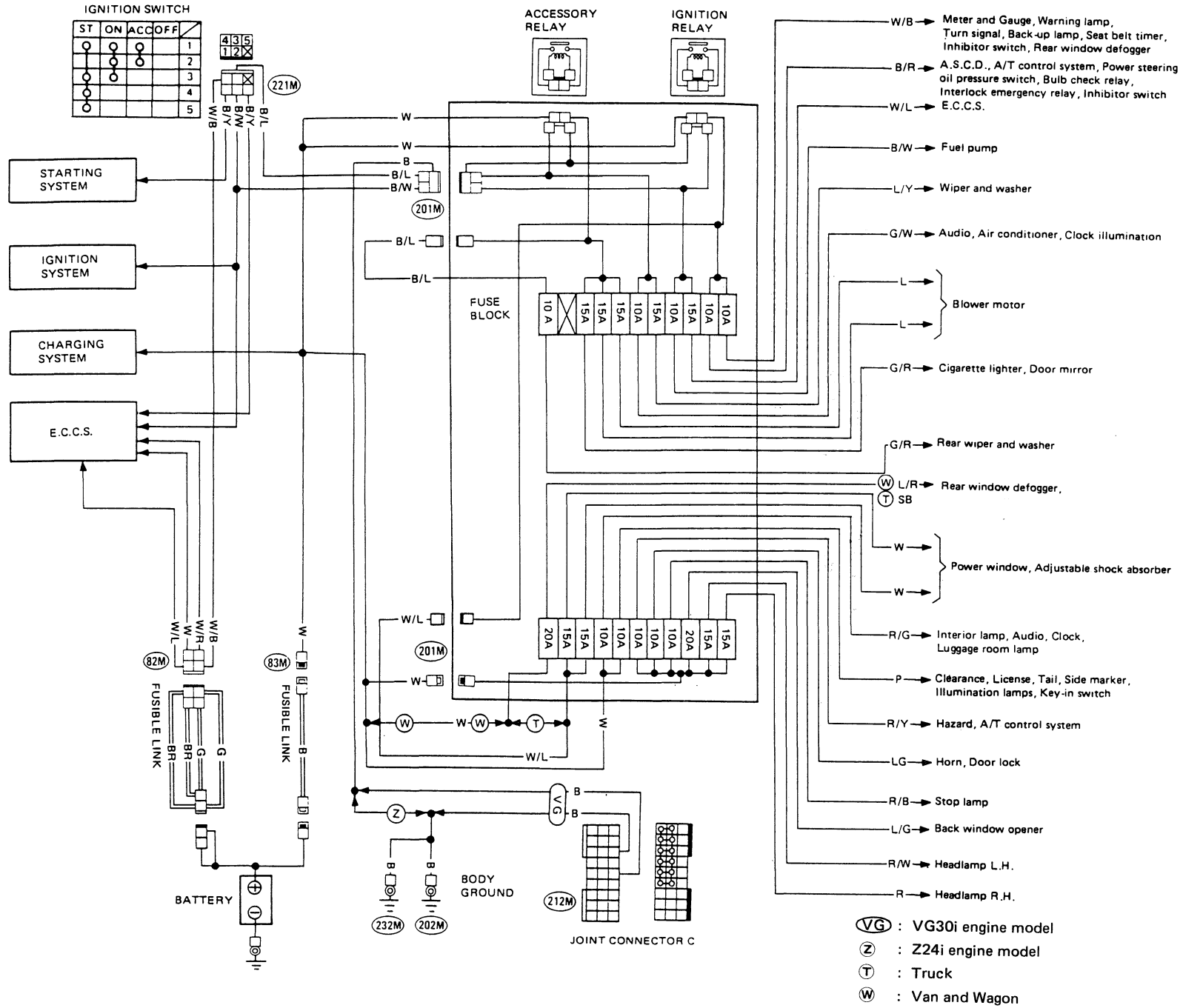

Wiring Diagram

BATTERY

CAUTION:

- a. If it becomes necessary to start the engine with a booster battery and jumper cables, use a 12-volt booster battery.
- b. After connecting battery cables, ensure that they are tightly clamped to battery terminals for good contact.
- c. Never add distilled water through the hole used to check specific gravity.

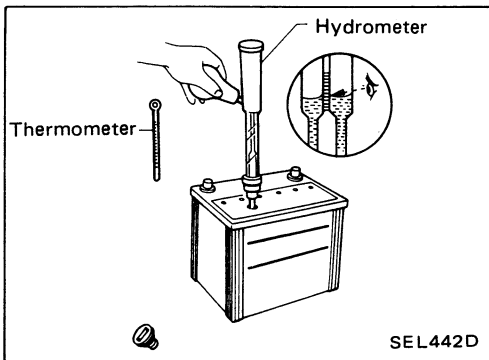
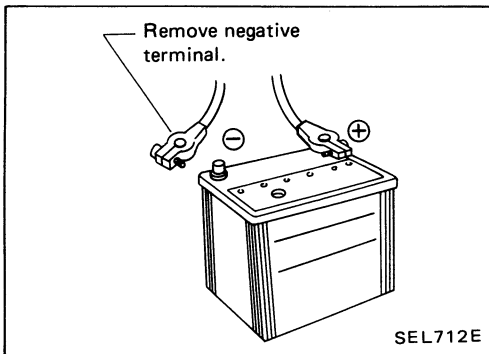
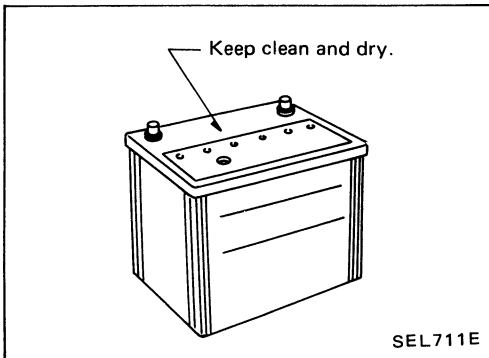

How to Handle Battery

METHODS OF PREVENTING OVER-DISCHARGE

The following precautions must be taken to prevent over-discharging a battery..

- The battery surface (particularly its top) should always be kept clean and dry.
If the top surface of a battery is wet with electrolyte or water, leakage current will cause the battery to discharge. Always keep the battery clean and dry.
- When the vehicle is not going to be used over a long period of time, disconnect the negative battery terminal. (If the vehicle has an extended storage switch, turn it off.)
- Check the charge condition of the battery.
Periodically check the specific gravity of the electrolyte. Keep a close check on charge condition to prevent over-discharge.

BATTERY

How to Handle Battery (Cont'd)

CHECKING ELECTROLYTE LEVEL

WARNING:

Do not allow battery fluid to come in contact with skin, eyes, fabrics, or painted surfaces. After touching a battery, do not touch or rub your eyes until you have thoroughly washed your hands. If the acid contacts the eyes, skin or clothing, immediately flush with water for 15 minutes and seek medical attention.

Normally the battery does not require additional water. However, when the battery is used under severe conditions, adding distilled water may be necessary during the battery life.

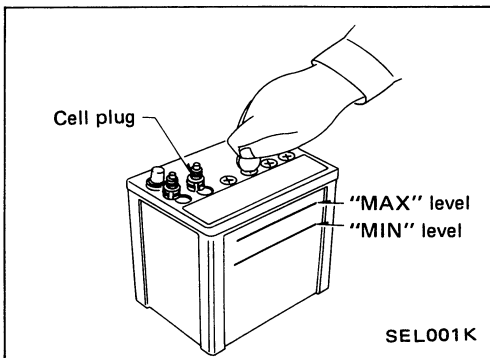

- Remove the cell plug using a suitable tool.
- Add distilled water up to the MAX level.

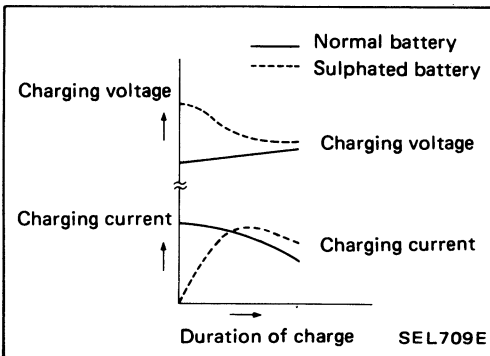

SULPHATION

When a battery has been left unattended for a long period of time and has a specific gravity of less than 1.100, it will be completely discharged, resulting in sulphation on the cell plates.

Compared with a battery discharged under normal conditions, the current flow in a "sulphated" battery is not as smooth although its voltage is high during the initial stage of charging, as shown in the figure at the left.

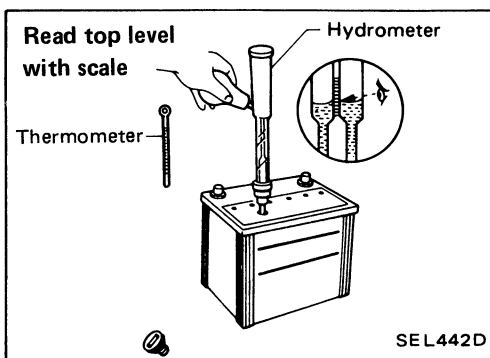

SPECIFIC GRAVITY CHECK

1. Read hydrometer and thermometer indications at eye level.

BATTERY

How to Handle Battery (Cont'd)

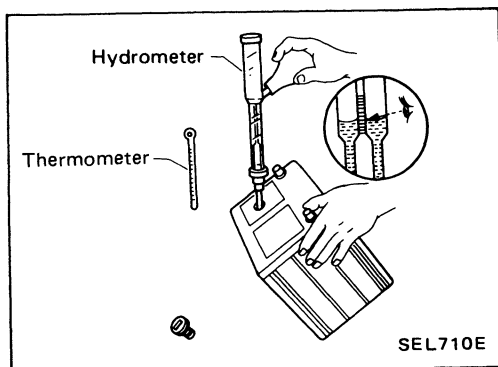

- When electrolyte level is too low, tilt battery case to raise it for easy measurement.

2. Convert into specific gravity at 20°C (68°F).

Example:

- When electrolyte temperature is 35°C (95°F) and specific gravity of electrolyte is 1.230, converted specific gravity at 20°C (68°F) is 1.240.
- When electrolyte temperature is 0°C (32°F) and specific gravity of electrolyte is 1.210, converted specific gravity at 20°C (68°F) is 1.196.

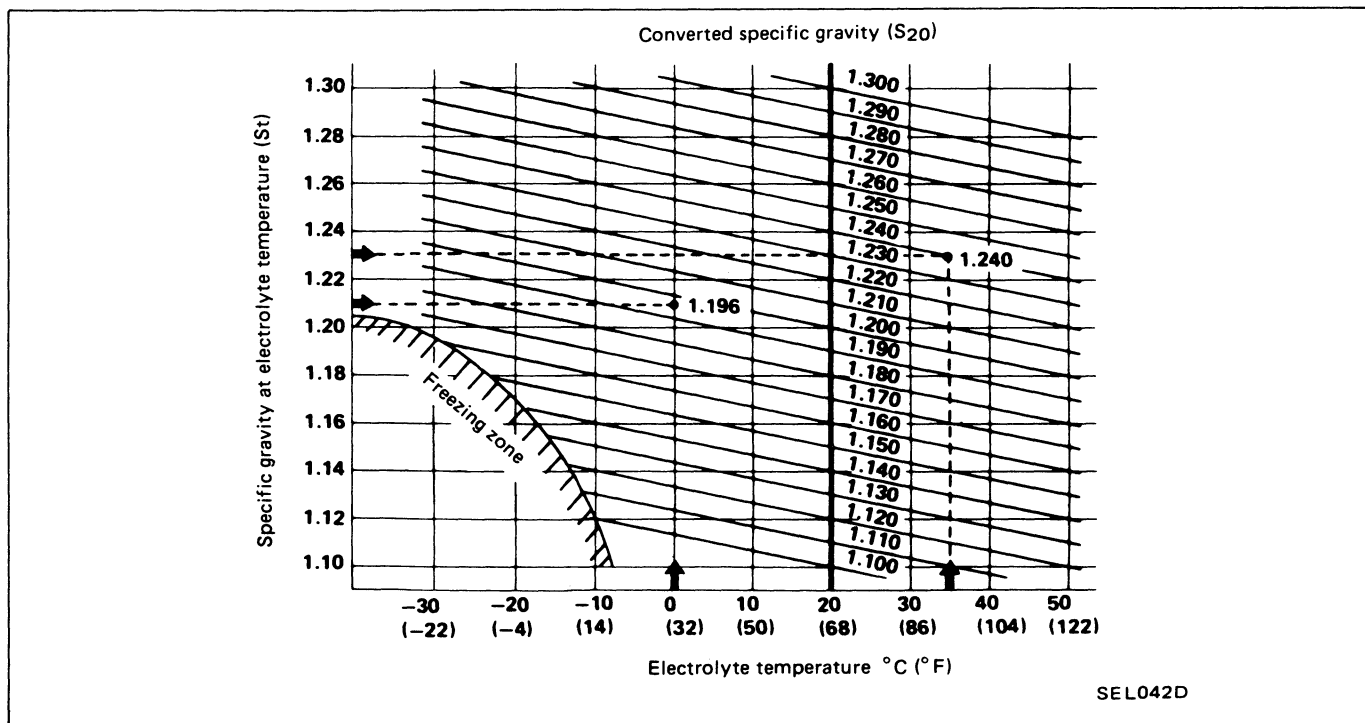

BATTERY

Battery Test and Charging Chart

Chart I

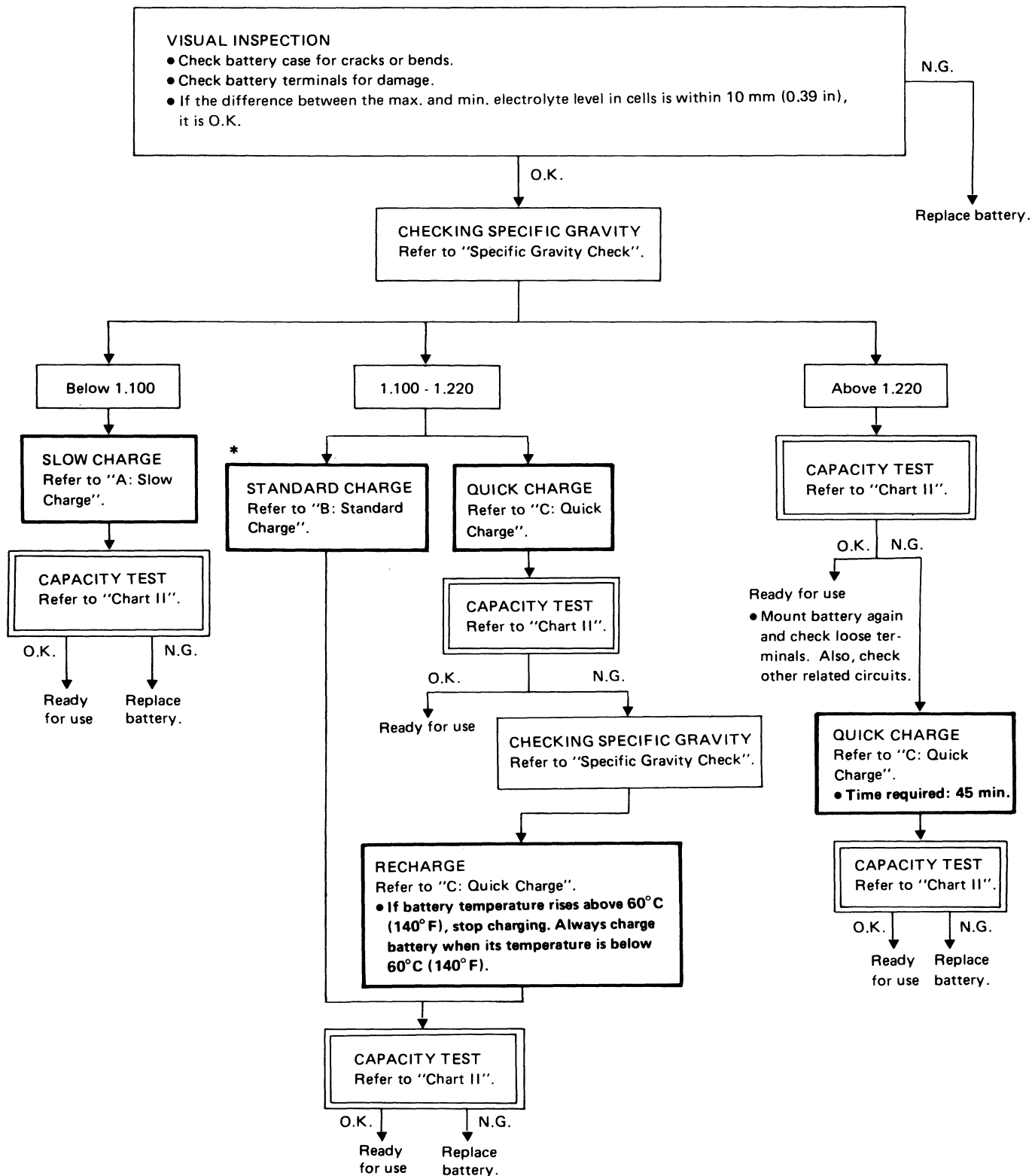

* "STANDARD CHARGE" is recommended in case that the vehicle is in storage after charging.

BATTERY

Battery Test and Charging Chart (Cont'd)

Chart II

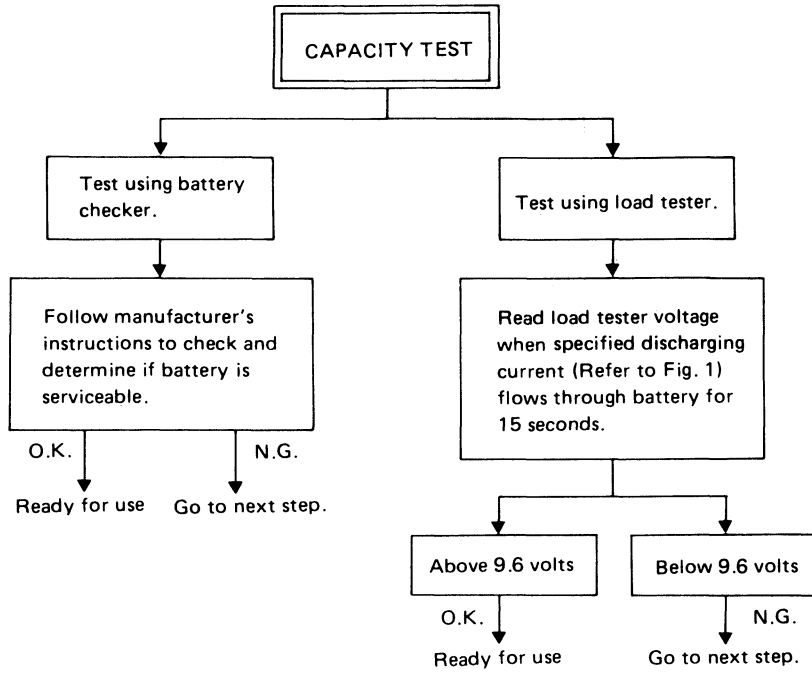

- Check battery type and determine the specified current using the following table.

Fig. 1 DISCHARGING CURRENT (Load tester)

Type	Current (A)
28B19R(L)	90
34B19R(L)	99
46B24R(L)	135
55B24R(L)	135
50D23R(L)	150
55D23R(L)	180
65D26R(L)	195
80D26R(L)	195
75D31R(L)	210
95D31R(L)	240
95E41R(L)	300
130E41R(L)	330

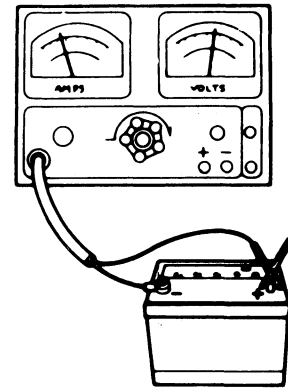

SEL697B

BATTERY

Battery Test and Charging Chart (Cont'd)

A: SLOW CHARGE

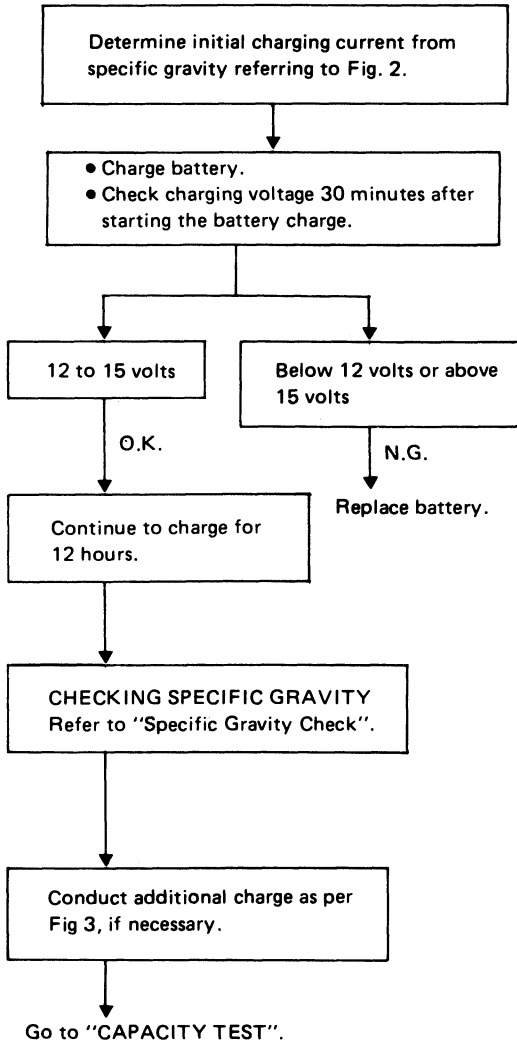
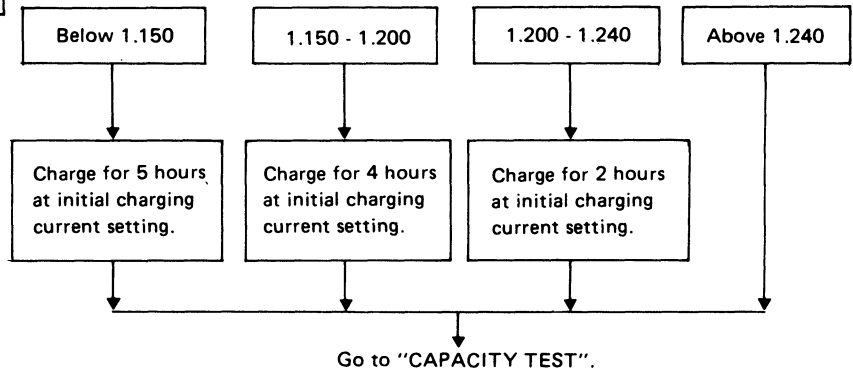

Fig. 2 INITIAL CHARGING CURRENT SETTING (Slow charge)

BATTERY TYPE CON- VERTED SPECIFIC GRAVITY	28B19R(L) 34B19R(L)	46B24R(L) 55B24R(L)	50D23R(L) 55D23R(L)	65D26R(L) 80D26R(L)	75D31R(L)	95D31R(L) 95E41R(L)	130E41R(L)
Below 1.100	4.0 (A)	5.0 (A)	7.0 (A)	8.0 (A)	9.0 (A)	10.0 (A)	14.0 (A)

- Check battery type and determine the specified current using the table shown above.
- After starting charging, adjustment of charging current is not necessary.

Fig. 3 ADDITIONAL CHARGE (Slow charge)



CAUTION:

- Set charging current to value specified in Fig. 2. If charger is not capable of producing specified current value, set its charging current as close to that value as possible.
- Keep battery away from open flame while it is being charged.
- When connecting charger, connect leads first, then turn on charger. Do not turn on charger first, as this may cause a spark.
- If battery temperature rises above 60°C (140°F), stop charging. Always charge battery when its temperature is below 60°C (140°F).

BATTERY

Battery Test and Charging Chart (Cont'd)

B: STANDARD CHARGE

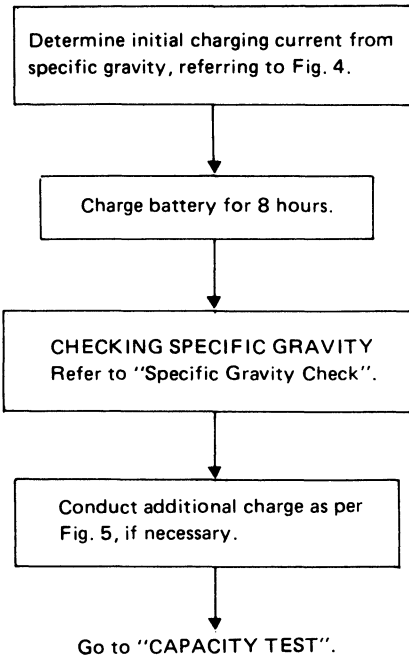
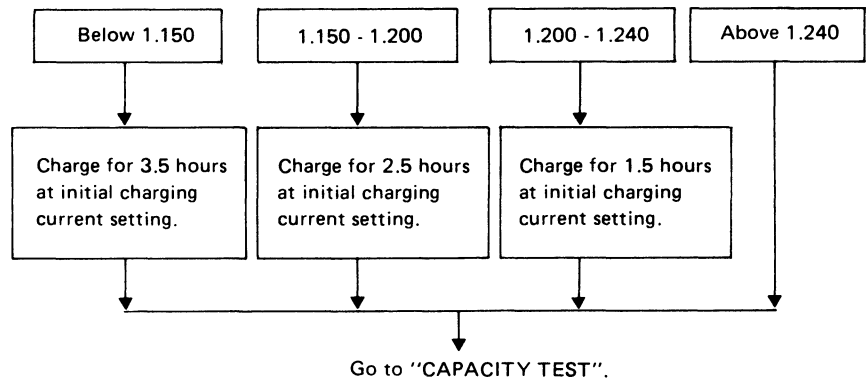

Fig. 4 INITIAL CHARGING CURRENT SETTING
(Standard charge)

BATTERY TYPE CON- VERTED SPECIFIC GRAVITY	28B19R(L) 34B19R(L)	46B24R(L) 55B24R(L)	50D23R(L) 55D23R(L)	65D26R(L) 80D26R(L)	75D31R(L)	95D31R(L) 95E41R(L)	130E41R(L)
1.100 - 1.130	4.0 (A)	5.0 (A)	6.0 (A)	7.0 (A)	8.0 (A)	9.0 (A)	13.0 (A)
1.130 - 1.160	3.0 (A)	4.0 (A)	5.0 (A)	6.0 (A)	7.0 (A)	8.0 (A)	11.0 (A)
1.160 - 1.190	2.0 (A)	3.0 (A)	4.0 (A)	5.0 (A)	6.0 (A)	7.0 (A)	9.0 (A)
1.190 - 1.220	2.0 (A)	2.0 (A)	3.0 (A)	4.0 (A)	5.0 (A)	5.0 (A)	7.0 (A)

- Check battery type and determine the specified current using the table shown above.
- After starting charging, adjustment of charging current is not necessary.

Fig. 5 ADDITIONAL CHARGE (Standard charge)



CAUTION:

- Do not use standard charge method on a battery whose specific gravity is less than 1.100.
- Set charging current to value specified in Fig. 4. If charger is not capable of producing specified current value, set its charging current as close to that value as possible.
- Keep battery away from open flame while it is being charged.
- When connecting charger, connect leads first, then turn on charger. Do not turn on charger first, as this may cause a spark.
- If battery temperature rises above 60°C (140°F), stop charging. Always charge battery when its temperature is below 60°C (140°F).

BATTERY

Battery Test and Charging Chart (Cont'd)

C: QUICK CHARGE

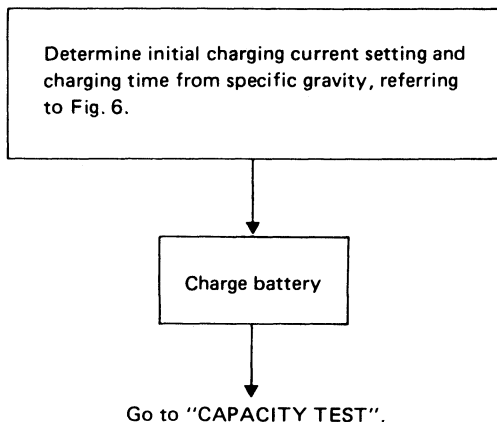

Fig. 6 INITIAL CHARGING CURRENT SETTING AND CHARGING TIME (Quick charge)

CON- VERTED SPECIFIC GRAVITY	BATTERY TYPE		CUR- RENT [A]	28B19R(L) 34B19R(L)	46B24R(L) 55B24R(L) 50D23R(L)	55D23R(L) 65D26R(L) 80D26R(L)	75D31R(L) 95D31R(L) 95E41R(L)	130E41R(L)
	CURRENT [A]							
			10 (A)	15 (A)	20 (A)	30 (A)	40 (A)	
1.100 - 1.130	2.5 hours							
1.130 - 1.160	2.0 hours							
1.160 - 1.190	1.5 hours							
1.190 - 1.220	1.0 hours							
Above 1.220	0.75 hours (45 min.)							

- Check battery type and determine the specified current using the table shown above.
- After starting charging, adjustment of charging current is not necessary.

CAUTION:

- Do not use quick charge method on a battery whose specific gravity is less than 1.100.
- Set initial charging current to value specified in Fig. 6. If charger is not capable of producing specified current value, set its charging current as close to that value as possible.
- Keep battery away from open flame while it is being charged.
- When connecting charger, connect leads first, then turn on charger. Do not turn on charger first, as this may cause a spark.
- Be careful of a rise in battery temperature because a large current flow is required during quick-charge operation.
If battery temperature rises above 60°C (140°F), stop charging. Always charge battery when its temperature is below 60°C (140°F).
- Do not exceed the charging time specified in Fig. 6, because charging battery over the charging time can cause deterioration of the battery.

Service Data and Specifications (S.D.S.)

Applied area	U.S.A.	Canada	
Engine	All	Z24i	VG30i
Type	55D23R	65D26R	75D31R
Capacity	V-AH	12-60	12-70

STARTING SYSTEM

Schematic

4-WHEEL DRIVE MODEL

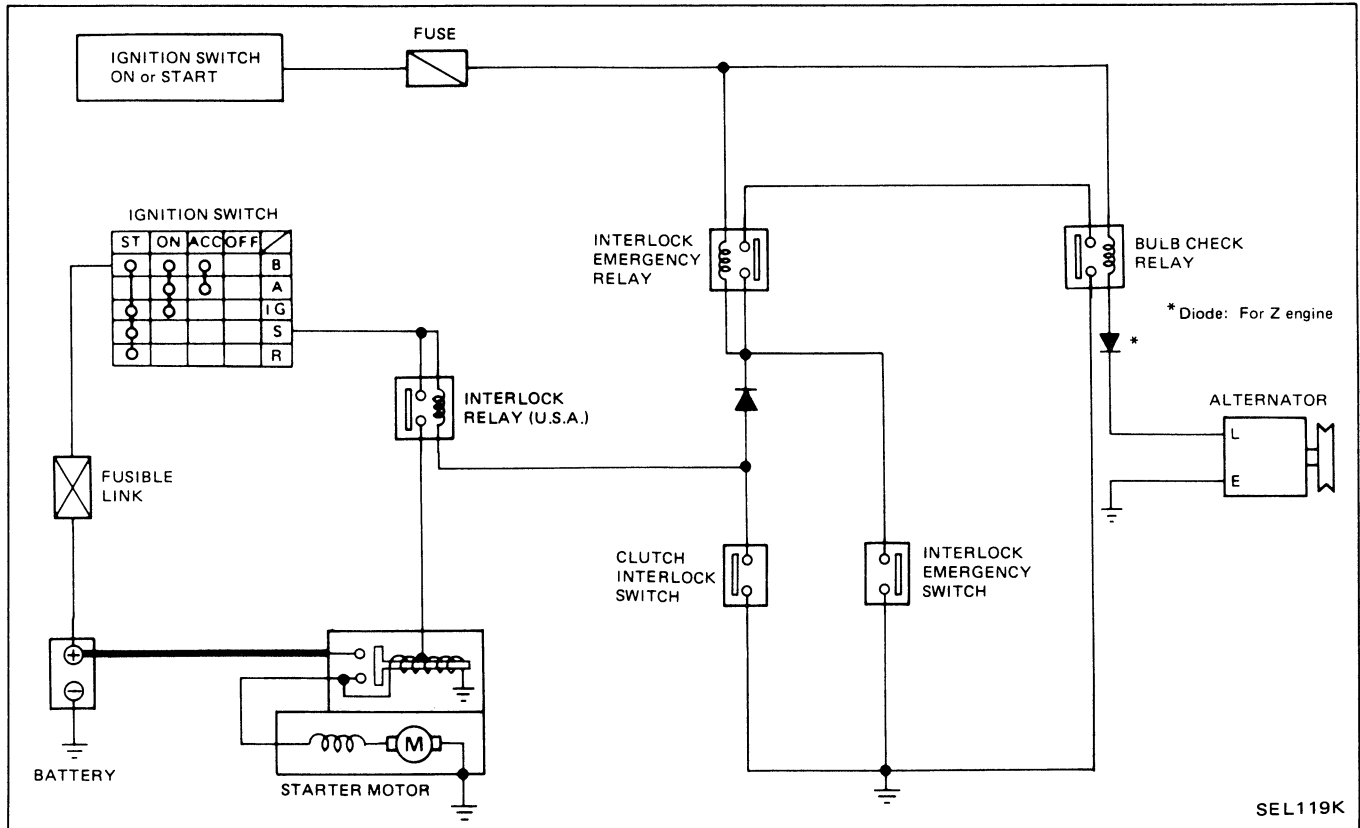

STARTING SYSTEM

Wiring Diagram

VG ENGINE MODEL
M/T model

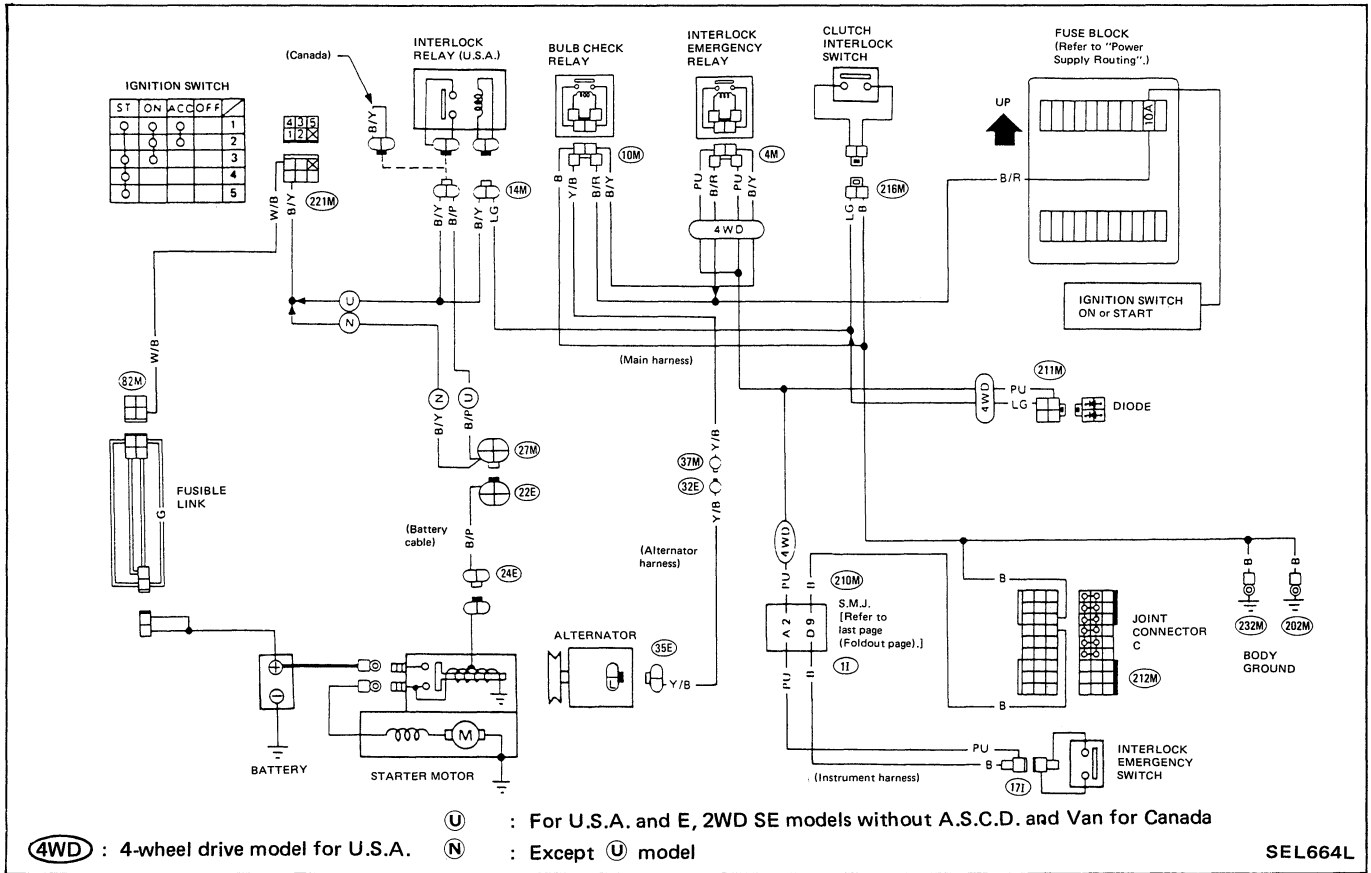

A/T model

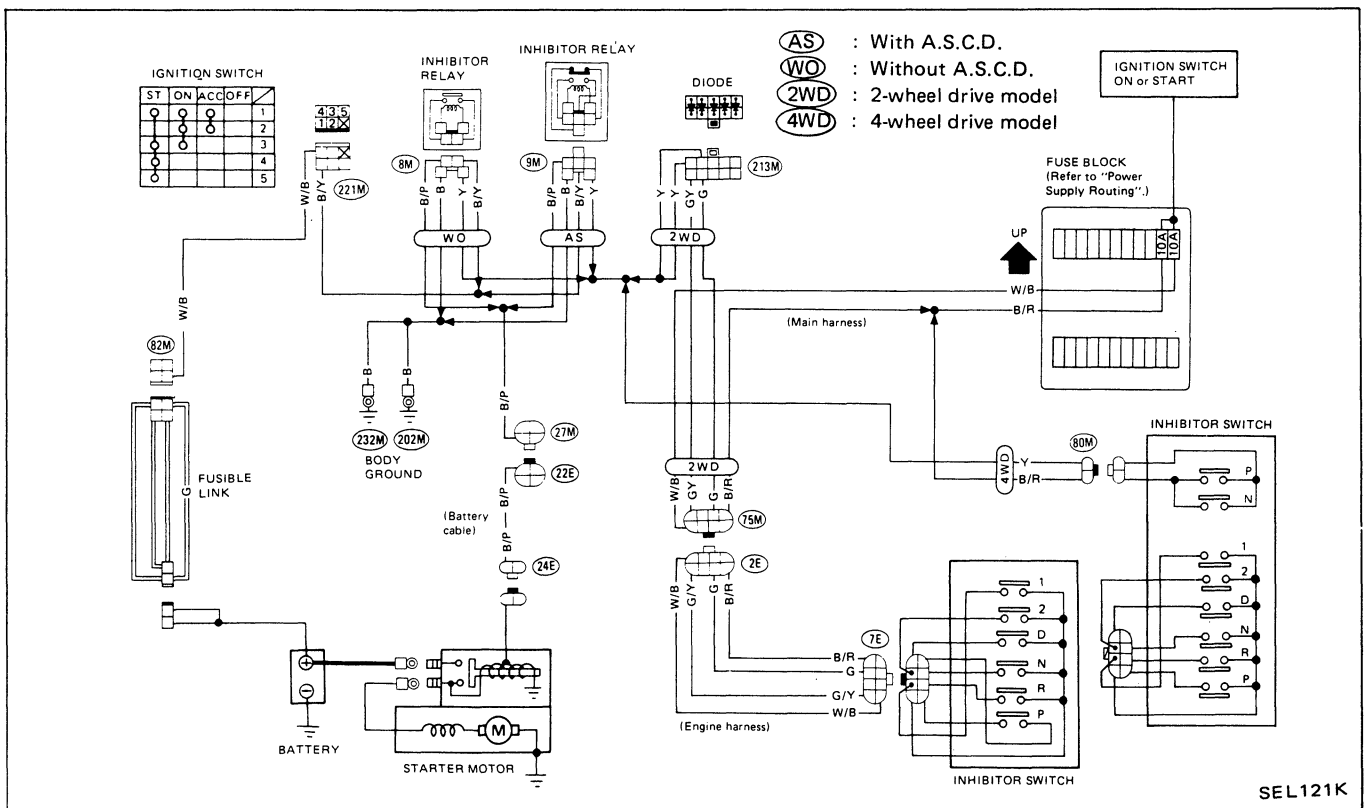

STARTING SYSTEM

Wiring Diagram (Cont'd)

Z ENGINE MODEL

M/T model

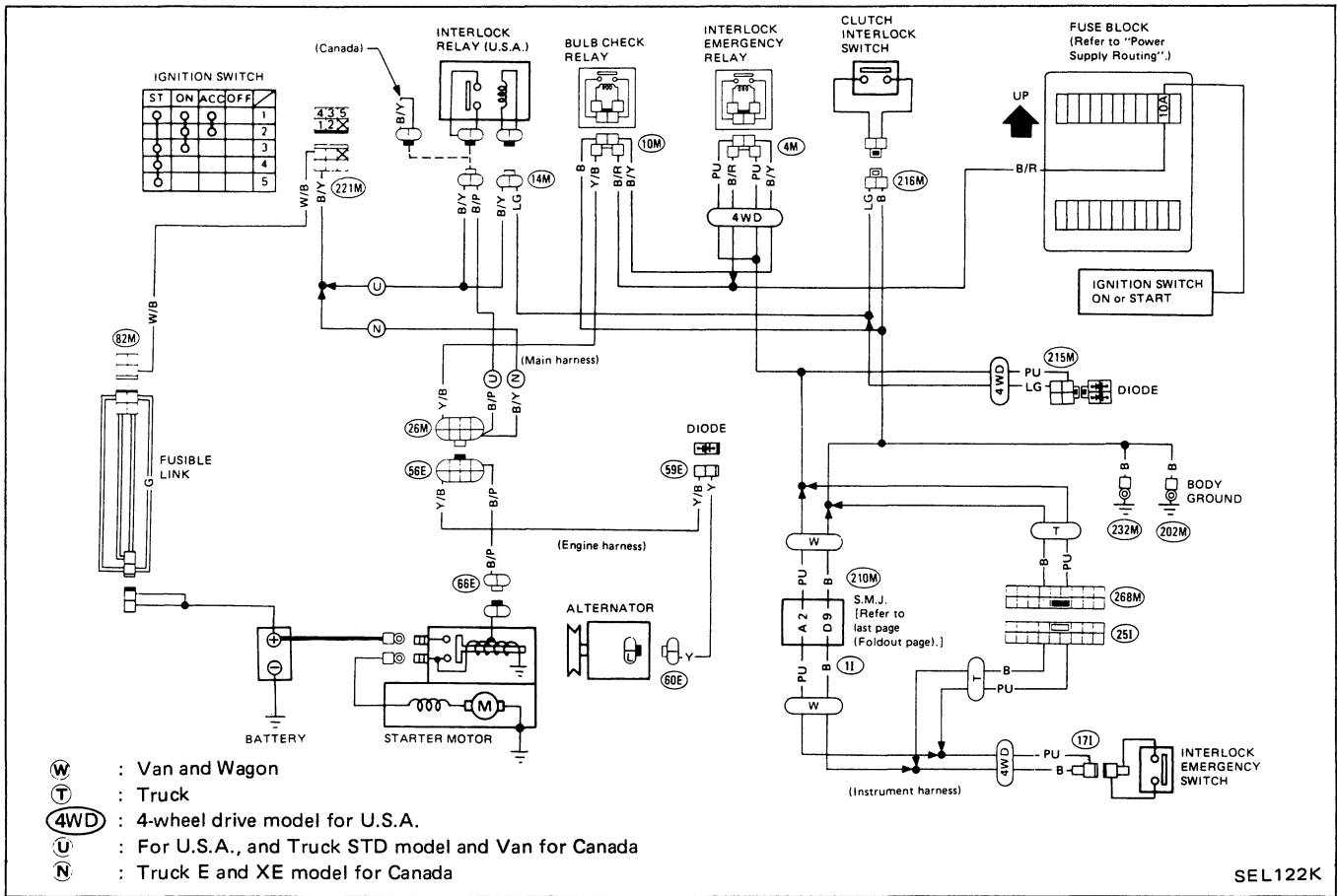

A/T model

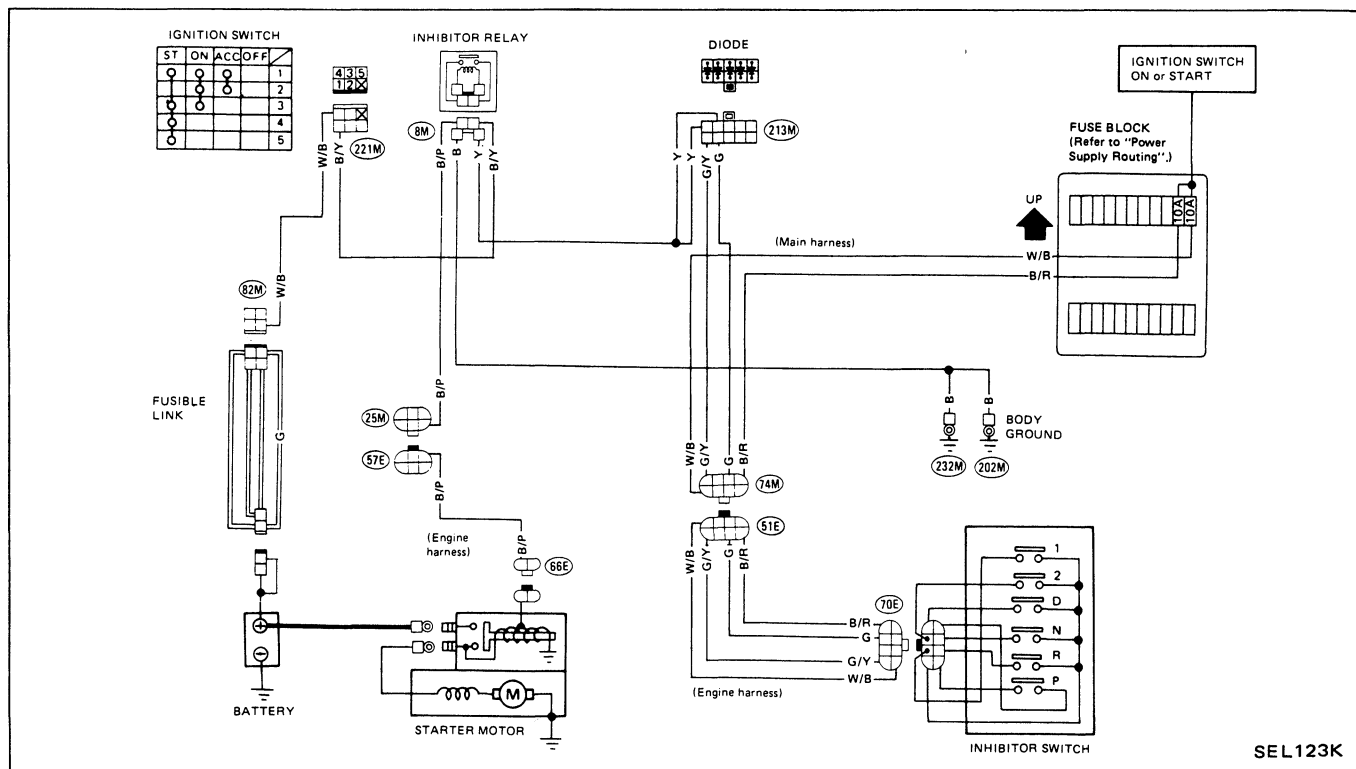

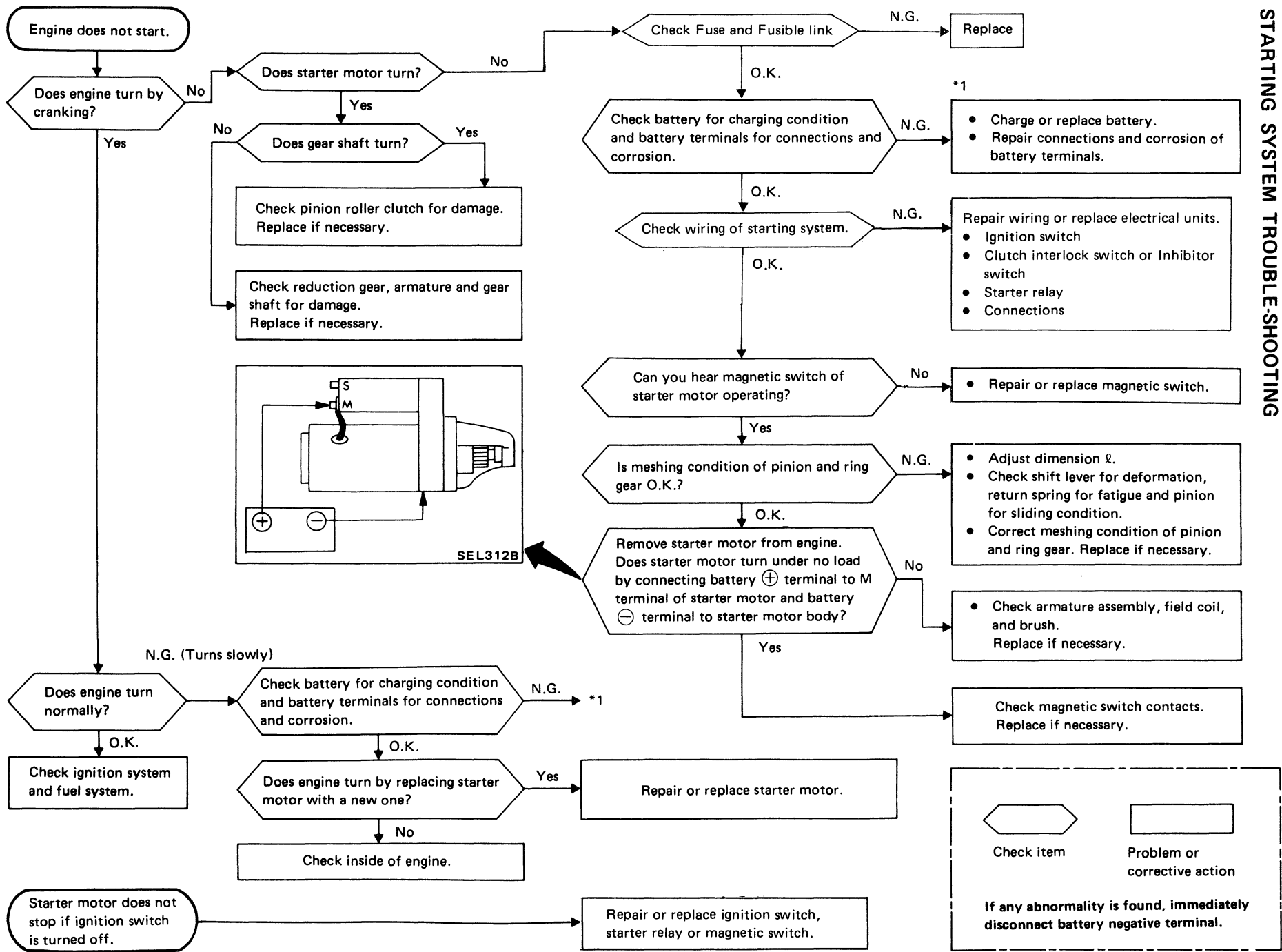

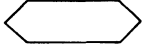
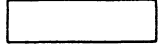
 Check item
  Problem or corrective action

If any abnormality is found, immediately disconnect battery negative terminal.

Construction

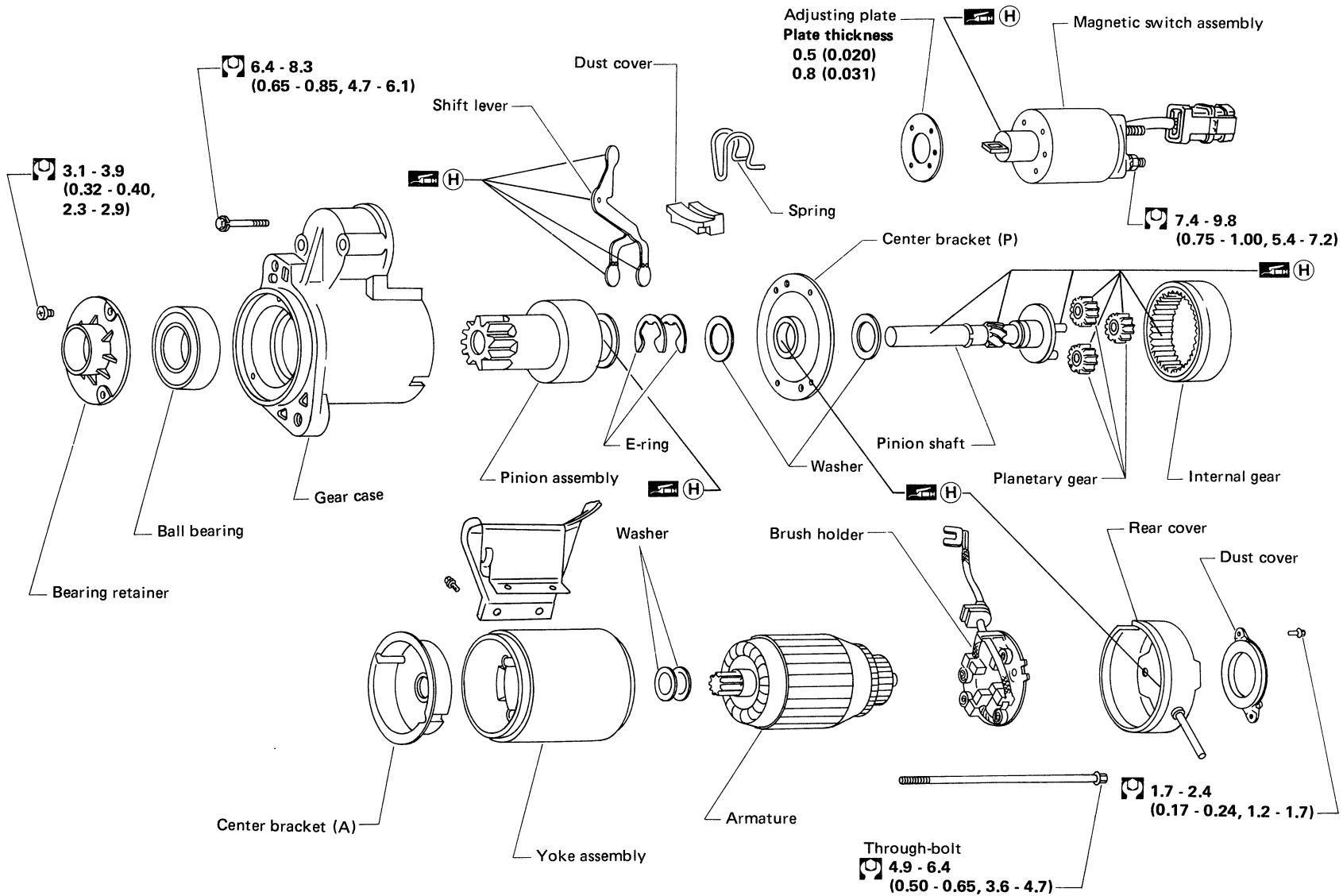

EL-19

SEL7231

Unit: mm (in)

: N-m (kg-m, ft-lb)

: High-temperature grease points

STARTING SYSTEM — Starter —
Construction (Cont'd)

S114-605, -606B, -607 and -608A

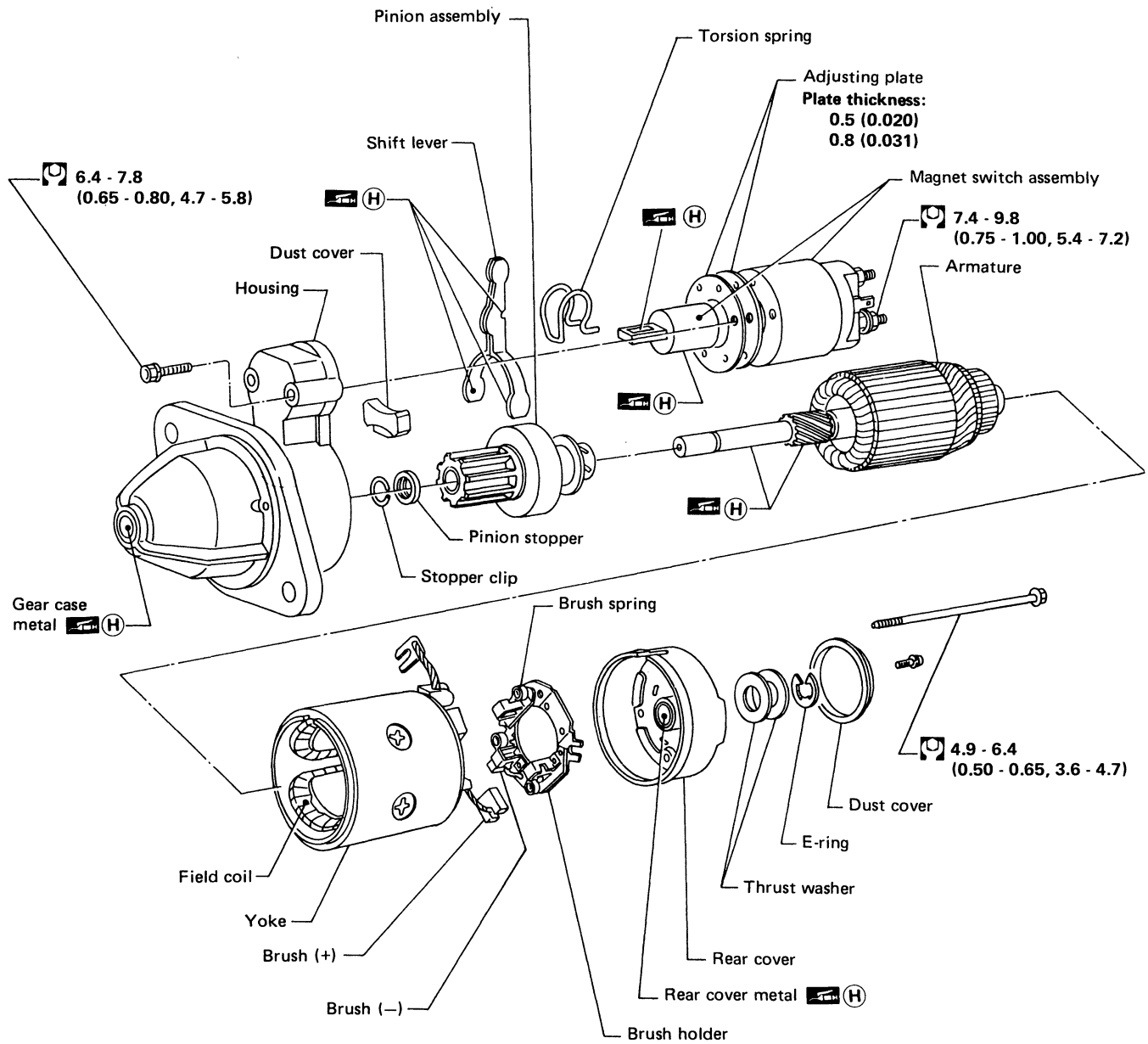

Unit: mm (in)

: N·m (kg·m, ft·lb)

(H) : High-temperature grease points

EL-20

SEL245C

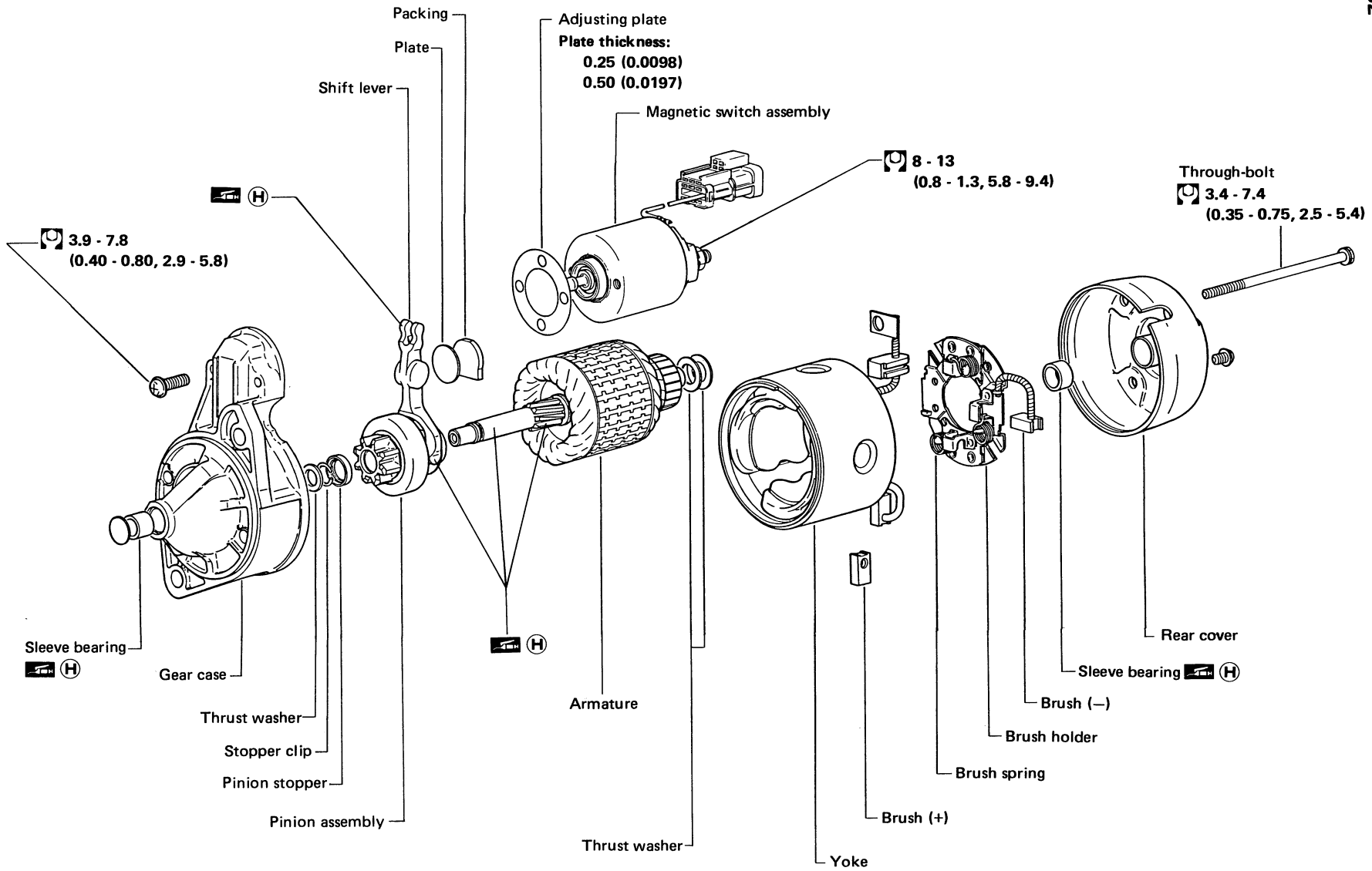

EL-21

SEL3171

Unit: mm (in)

: N·m (kg-m, ft-lb)

: High-temperature grease points

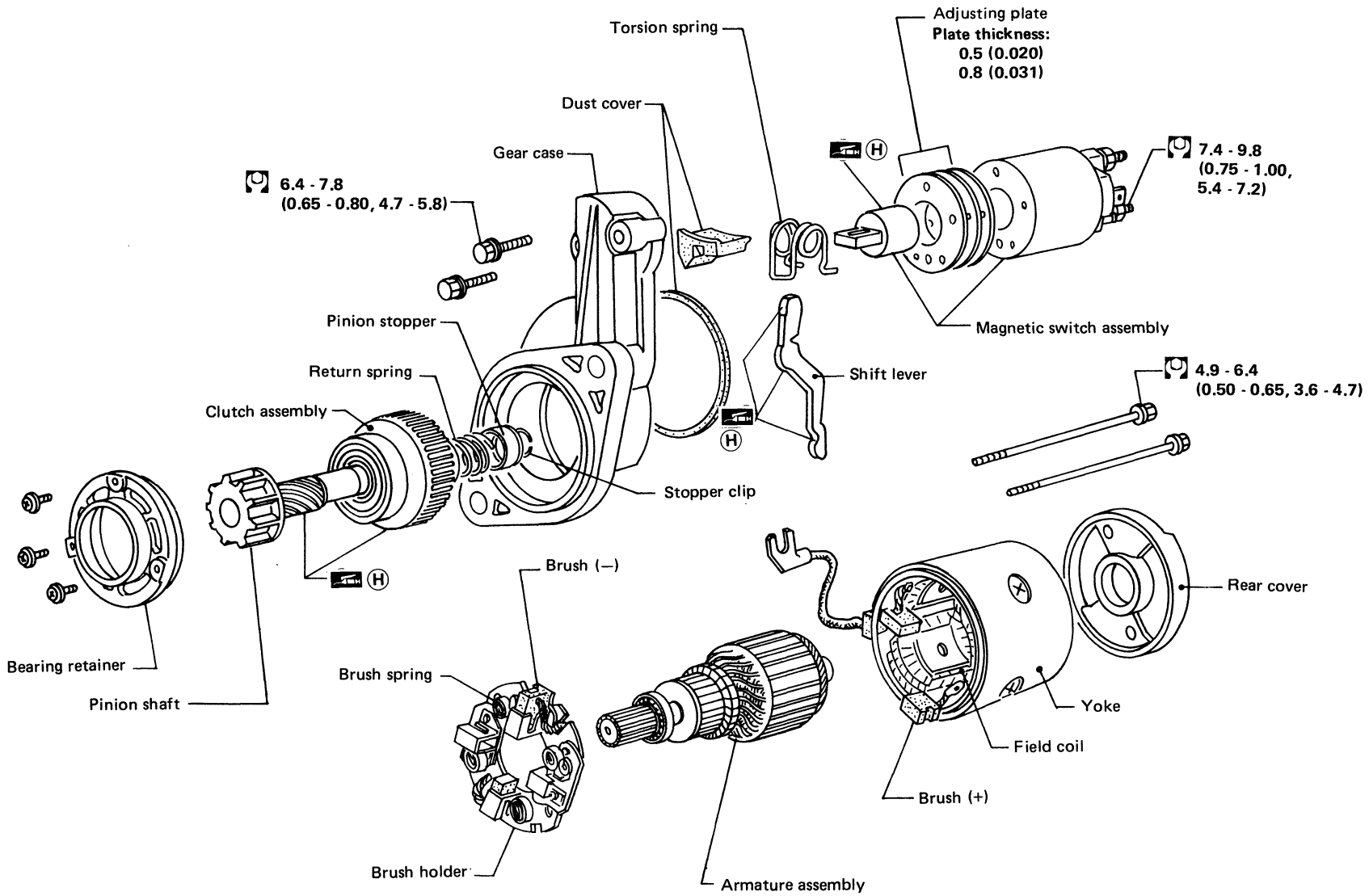

EL-22

SEL5578

Unit: mm (in)
Ⓜ : N-m (kg-m, ft-lb)
Ⓜ : High-temperature grease points

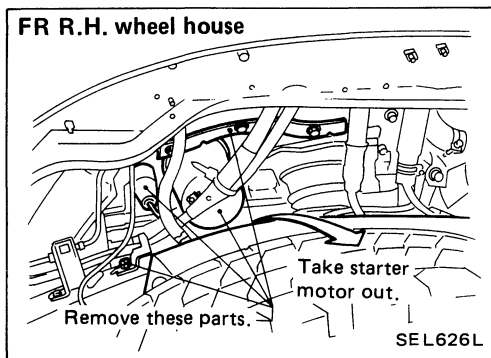

Removal and Installation (VG30i engine model) 4WD TRUCK

Remove the following parts to make room and take out starter through the clearance between body and frame.

- FR R.H. splash guard
- Oil pressure switch connector
- Oil filter
- Exhaust manifold heat insulater
- Fuel tube retainer bolt

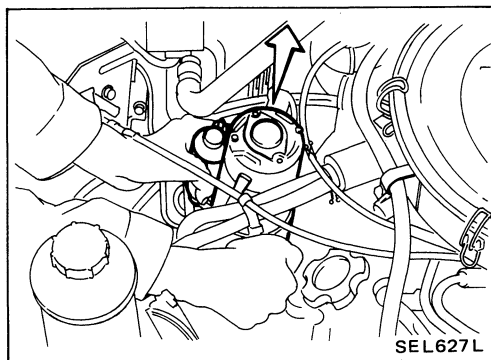

EXCEPT 4WD TRUCK

Remove following parts to make room and take out starter from the cylinder head side area.

- FR R.H. wheel
- FR R.H. splash guard
- Exhaust manifold heat insulater
- Exhaust manifold
- Oil Filter
- Oil pressure switch connector

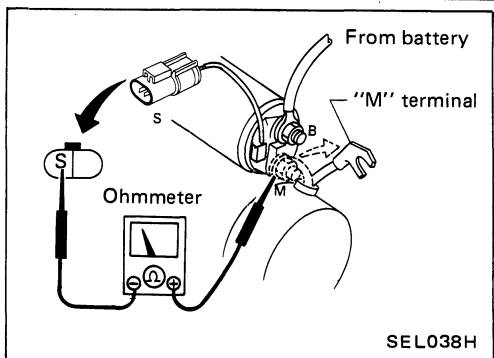
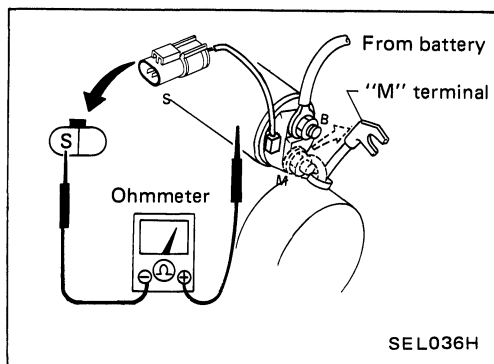

Magnetic Switch Check

- Before starting to check, disconnect battery ground cable.
 - Disconnect "M" terminal of starter motor.
1. Continuity test (between "S" terminal and switch body).
 - No continuity ... Replace.
2. Continuity test (between "S" terminal and "M" terminal).
 - No continuity ... Replace.

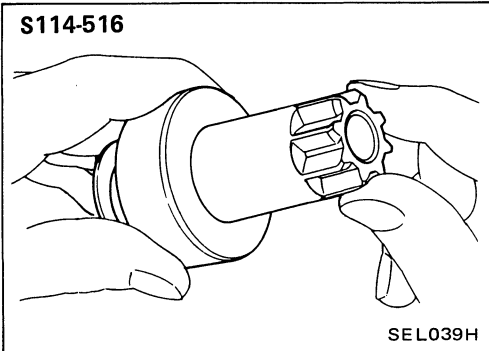

Pinion/Clutch Check

1. Check to see if pinion locks in one direction and rotates smoothly in the opposite direction.
- If it does not lock (or locks) in either direction or unusual resistance is evident ... Replace.

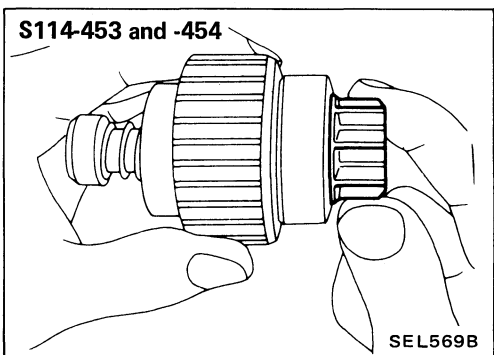
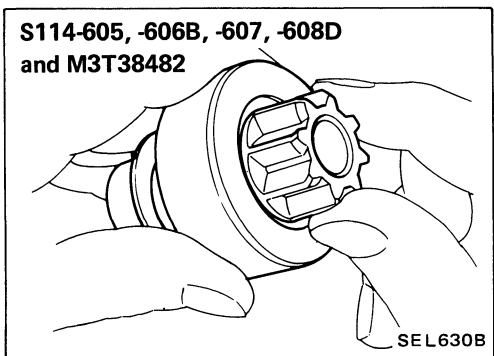

Pinion/Clutch Check (Cont'd)

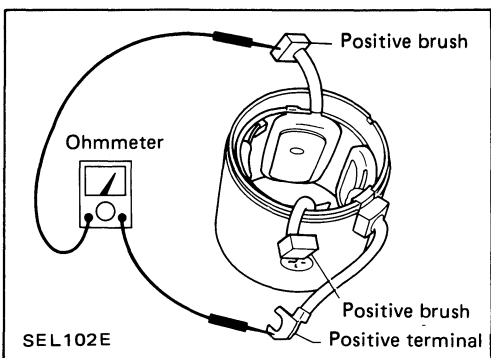
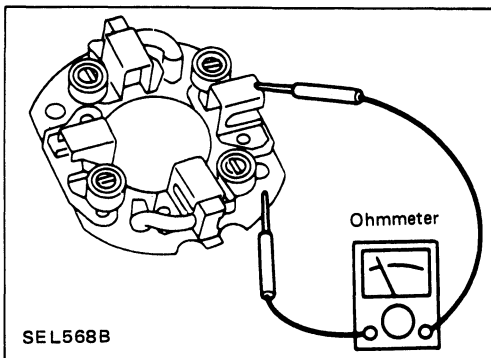
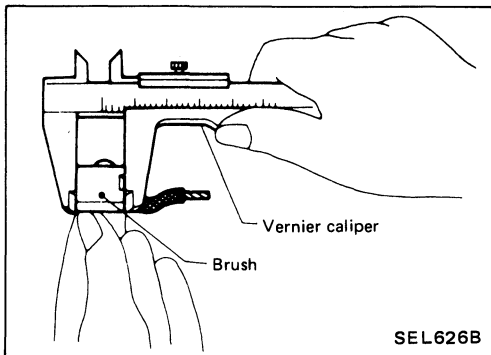
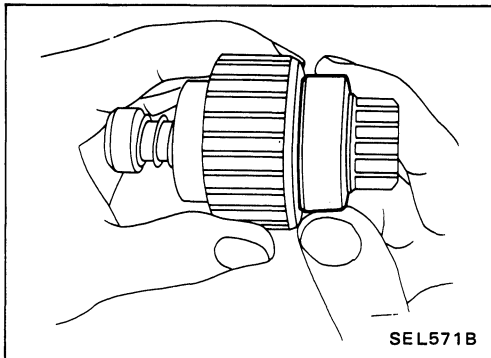
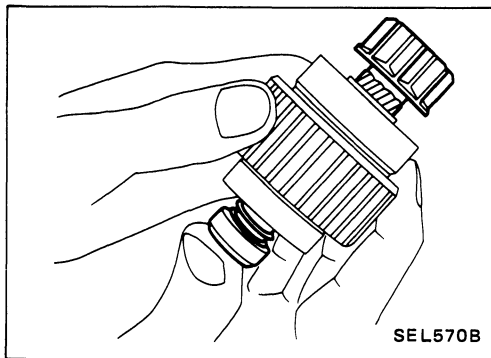

2. Check pinion movement. (S114-453 and -454)
 - If it is hard to move, apply grease or, if necessary, replace.

3. Check ball bearing. (S114-453 and -454)
 - Spin outer race of ball bearing to ensure that it turns smoothly without binding.
 - Abnormal resistance ... Replace.
4. Inspect pinion teeth.
 - Replace pinion if teeth are worn or damaged. (Also check condition of ring gear teeth.)
5. Inspect reduction gear teeth.
 - Replace reduction gear if teeth are worn or damaged. (Also check condition of armature shaft gear teeth.)

Brush Check

BRUSH

Check wear of brush.

Wear limit length:

Refer to "Service Data and Specifications."

- Excessive wear ... Replace.

BRUSH HOLDER

1. Perform insulation test between brush holder (positive side) and its base (negative side).
 - Continuity exists ... Replace.
2. Check brush to see if it moves smoothly.
 - If brush holder is bent, replace it; if sliding surface is dirty, clean.

Field Coil Check

1. Continuity test (between field coil positive terminal and positive brushes).
 - No continuity ... Replace field coil.

Field Coil Check (Cont'd)

2. Insulation test (between field coil positive terminal and yoke).
 - Continuity exists ... Replace field coil.

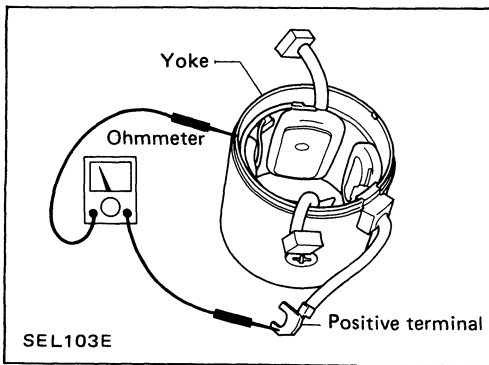

Yoke Assembly Check (S114-516)

Check magnet for cracks. If there is any crack, replace malfunctioning parts as an assembly.

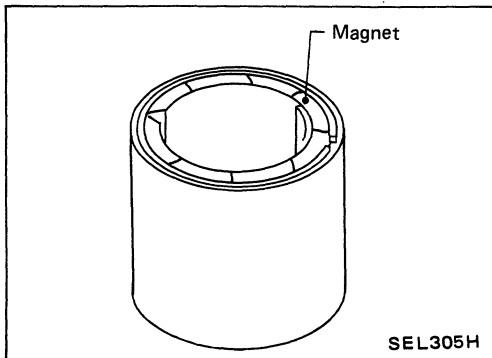

Armature Check

1. Continuity test (between two segments side by side).
 - No continuity ... Replace.

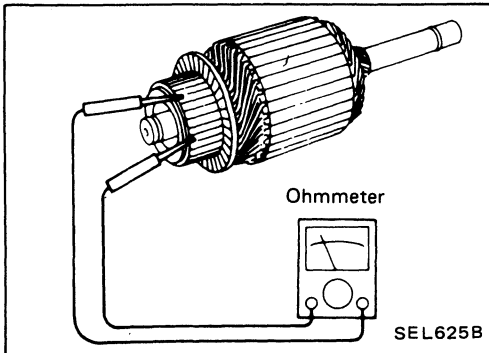

2. Insulation test (between each commutator and shaft).
 - Continuity exists ... Replace.

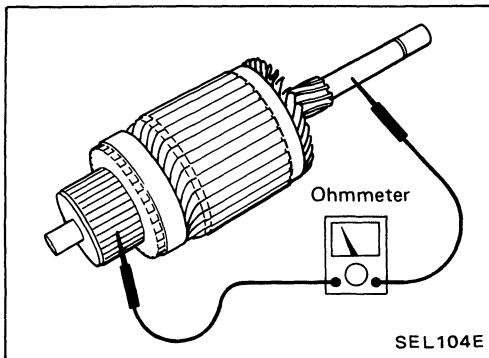

3. Check commutator surface.
 - Rough ... Sand lightly with No. 500 - 600 sandpaper.

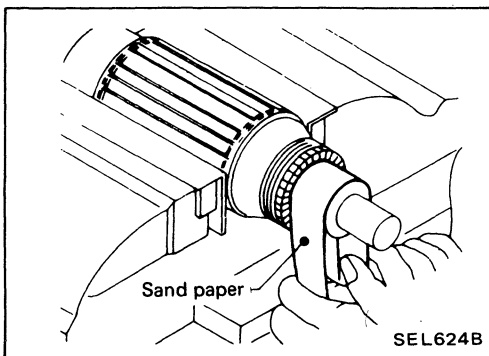

STARTING SYSTEM —Starter—

Armature Check (Cont'd)

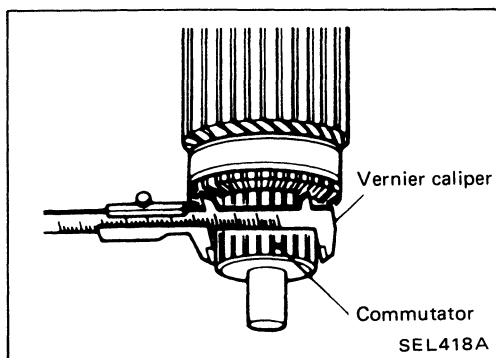

4. Check diameter of commutator.
Commutator minimum diameter:
Refer to "Service Data and Specifications."
 - Less than specified value ... Replace.

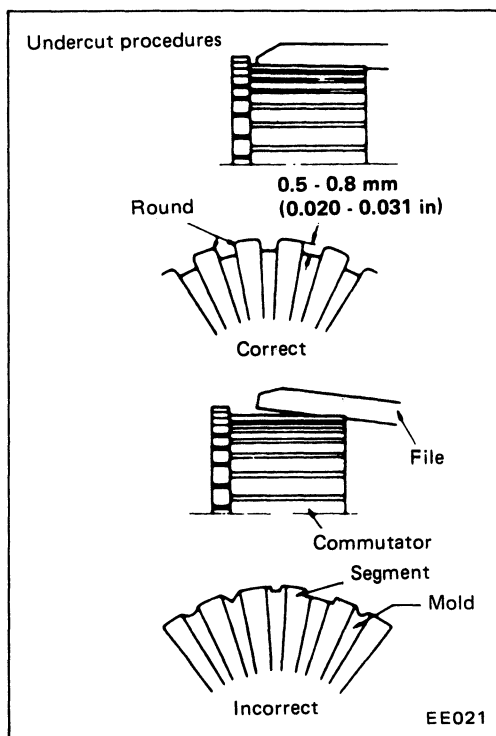

5. Check depth of insulating mold from commutator surface.
 - Less than 0.2 mm (0.008 in) ... Undercut to 0.5 - 0.8 mm (0.020 - 0.031 in)

Assembly

Carefully observe the following instructions.

HIGH-TEMPERATURE GREASE POINT

- Rear cover metal
- Gear case metal
- Center bracket metal
- Frictional surface of pinion
- Moving portion of shift lever
- Plunger of magnetic switch
- Reduction gear

PINION PROTRUSION LENGTH ADJUSTMENT

S114-607 and -608A

With pinion driven out by magnetic switch, push pinion back to remove slack and measure clearance "q" between the front edge of the pinion and the pinion stopper.

Clearance "q":

Refer to Service Data and Specifications.

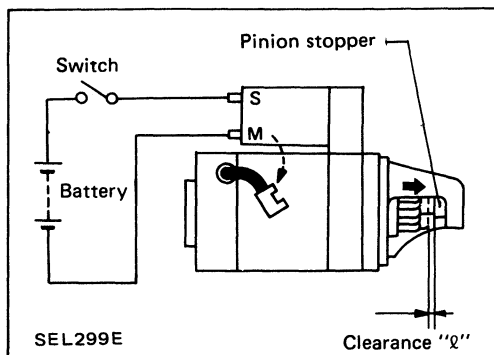

Assembly (Cont'd)

- Not in the specified value ... Adjust with adjusting plate.

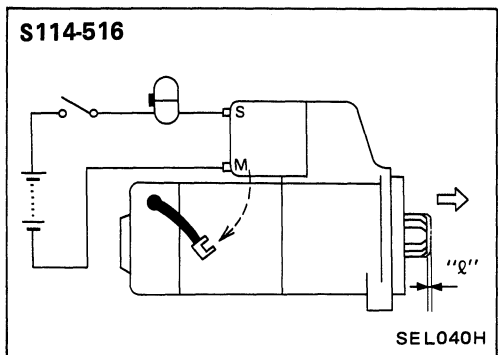
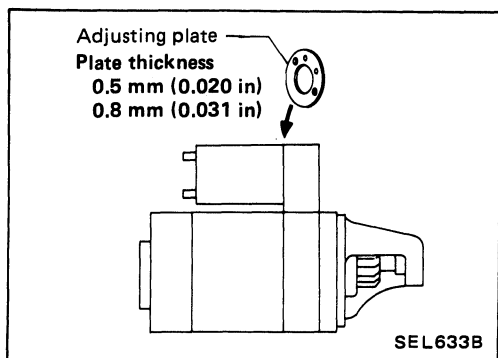

S114-516, -453 and -454

Measure movement "q" in height of pinion when pinion is pushed out with magnetic switch energized and when pinion is pulled out by hand until it touches stopper.

Movement "q":

Refer to Service Date and Specifications.

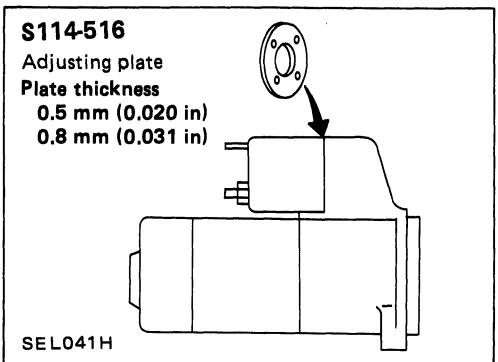
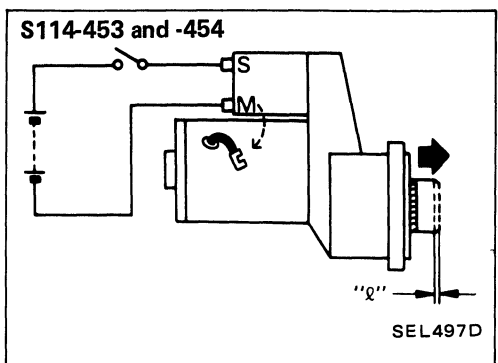

- Not in the specified value ... Adjust with adjusting plate.

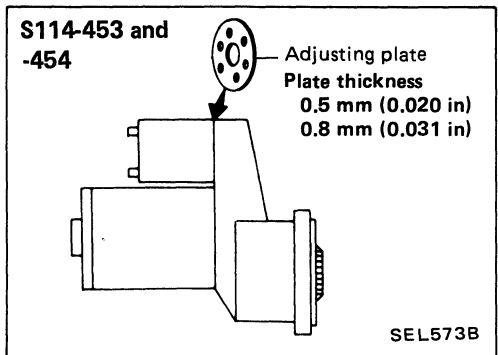

STARTER

Type	S114-516	S114-605	S114-607	M3T38482	S114-606B	S114-608D	S114-453	S114-454
	Reduction	Non-reduction				Reduction		
	HITACHI make			MITSUBISHI make	HITACHI make			
Applied model	VG30i	Z24i						
		U.S.A.					CANADA	U.S.A.
		2WD, M/T			2WD, A/T		4WD	All
System voltage	V	12						
No-load Terminal voltage	V	11.0	11.5				11.0	
Current	A	Less than 90	Less than 60	Less than 100	Less than 60		Less than 100	
Revolution	rpm	More than 2,650	More than 7,000		More than 6,500	More than 6,000		More than 3,900
Minimum diameter of commutator	mm (in)	More than 32 (1.26)	More than 39 (1.54)		More than 31.4 (1.236)	More than 39 (1.54)		More than 29 (1.14)
Minimum length of brush	mm (in)	11 (0.43)			11.5 (0.453)	11 (0.43)		
Brush spring tension	N (kg, lb)	17.7 - 21.6 (1.8 - 2.2, 4.0 - 4.9)			13.7 - 25.5 (1.4 - 2.6, 3.1 - 5.7)	17.7 - 21.6 (1.8 - 2.2, 4.0 - 4.9)		15.7 - 19.6 (1.6 - 2.0, 3.5 - 4.4)
Movement "ℓ" in height of pinion assembly	mm (in)	0.3 - 1.5 (0.012 - 0.059)	-				0.3 - 1.5 (0.012 - 0.059)	
Clearance of bearing metal and armature shaft	mm (in)	Less than 0.1 (0.004)	Less than 0.2 (0.008)		-	Less than 0.2 (0.008)		-
Clearance "ℓ" between pinion front edge and pinion stopper	mm (in)	-	0.3 - 2.5 (0.012 - 0.098)		0.5 - 2.0 (0.020 - 0.079)	0.3 - 2.5 (0.012 - 0.098)		-

EL-29

Service Data and Specifications (S.D.S.)

STARTING SYSTEM — Starter —

CHARGING SYSTEM

Wiring Diagram

VG ENGINE MODEL

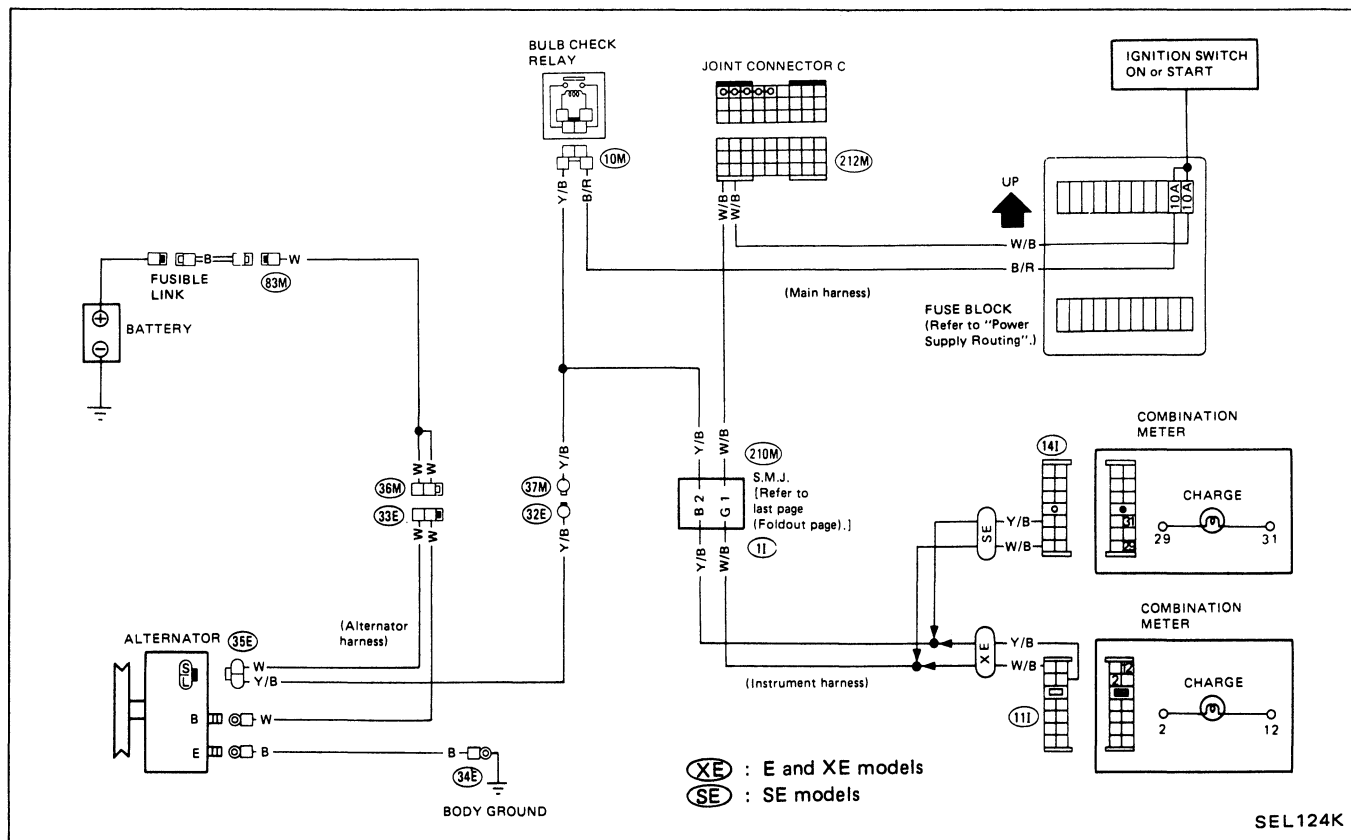

Z ENGINE MODEL

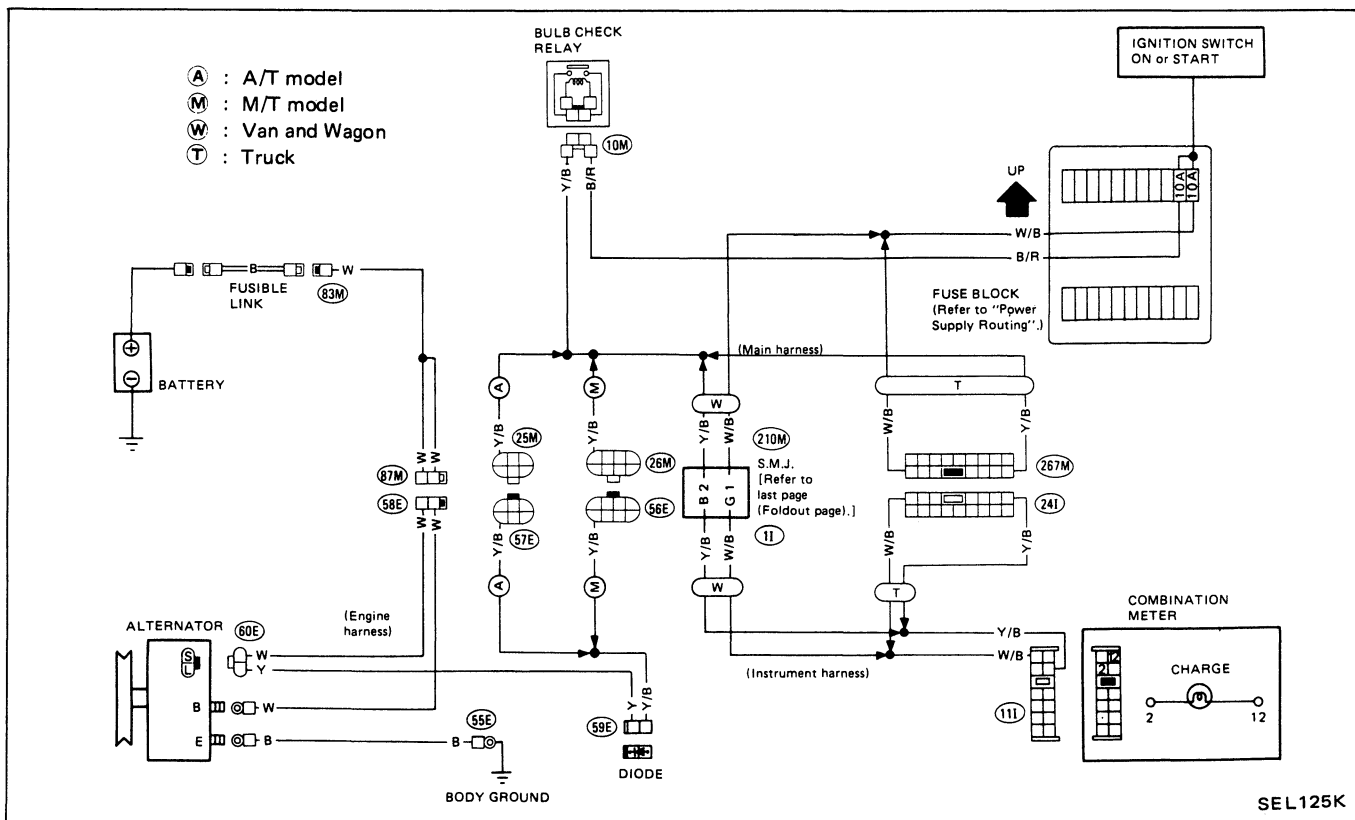

CHARGING SYSTEM

Trouble-shooting

Before conducting an alternator test, make sure that the battery is fully charged. A 30-volt voltmeter and suitable test probes are necessary for the test. The alternator can be checked easily by referring to the Inspection Table.

Before starting trouble-shooting, inspect the fusible link.

WITH IC REGULATOR

With alternator side L terminal grounded, internal short occurs if + diode is short-circuited.

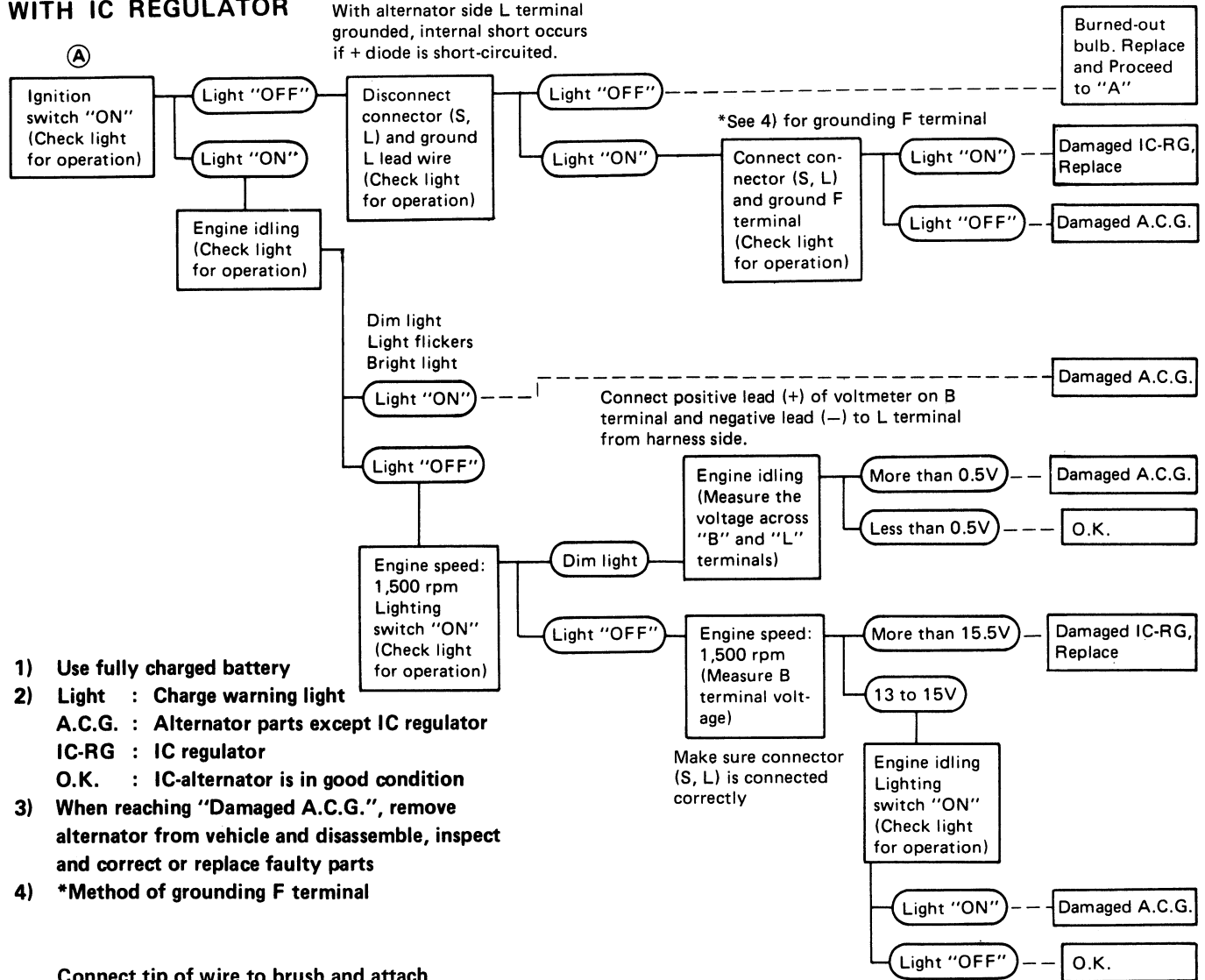

- 1) Use fully charged battery
- 2) Light : Charge warning light
A.C.G. : Alternator parts except IC regulator
IC-RG : IC regulator
O.K. : IC-alternator is in good condition
- 3) When reaching "Damaged A.C.G.", remove alternator from vehicle and disassemble, inspect and correct or replace faulty parts
- 4) *Method of grounding F terminal

Connect tip of wire to brush and attach wire to alternator body.

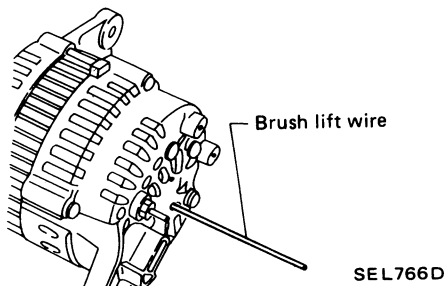

- 5) Terminals "S", "L", "BAT" and "E" are marked on rear cover of alternator.

CHARGING SYSTEM —Alternator—

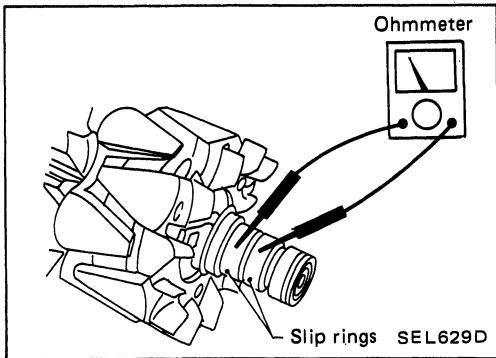
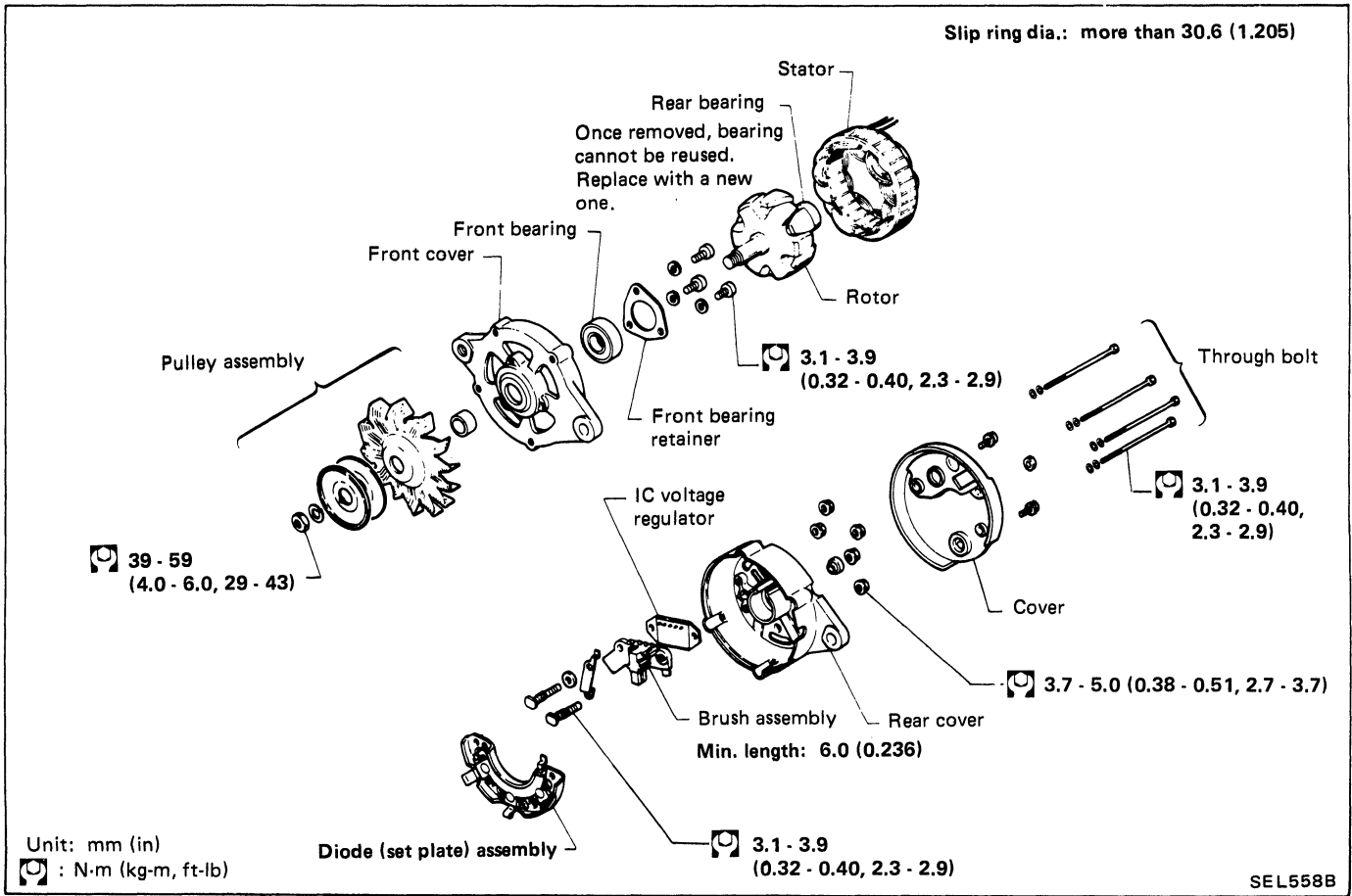

Rotor Slip Ring Check

1. Continuity test
 - No continuity ... Replace rotor.

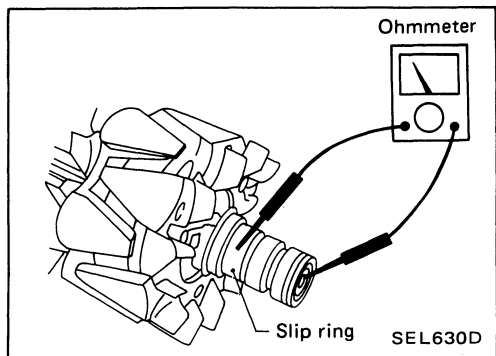

2. Insulator test
 - Continuity exists ... Replace rotor.
3. Check slip ring for wear.

Slip ring minimum outer diameter:

Refer to "Service Data and Specifications."

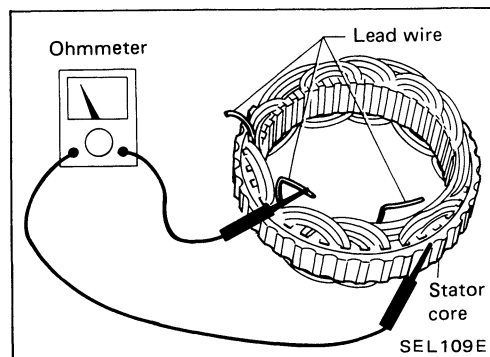
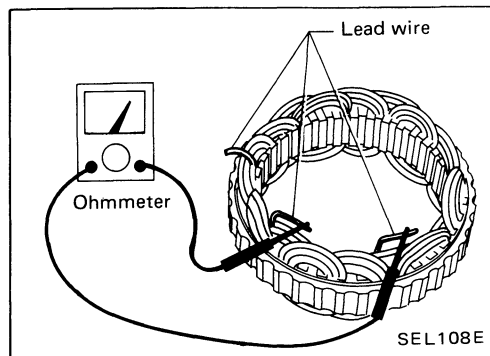
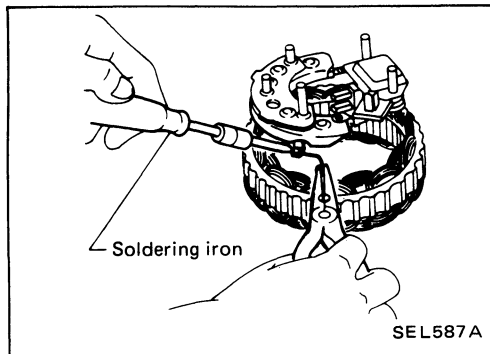
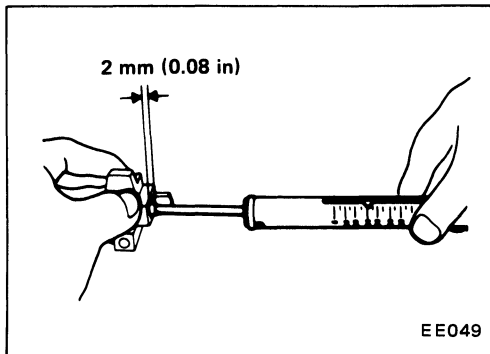
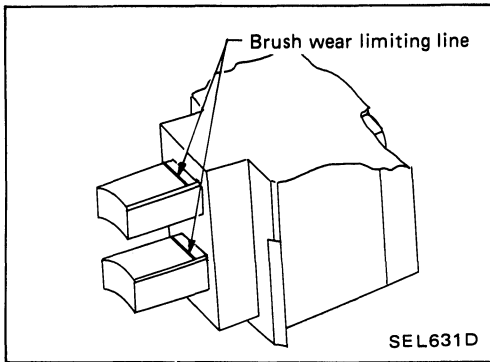

Brush Check

1. Check smooth movement of brush.
 - Not smooth ... Check brush holder and clean.
2. Check brush for wear.
 - Replace brush if it is worn down to the limit line.
3. Check brush lead wire for damage.
 - Damaged ... Replace.
4. Check brush spring pressure.

Measure brush spring pressure with brush projected approximately 2 mm (0.08 in) from brush holder.

Spring pressure:

Refer to "Service Data and Specifications."

 - Not within the specified values ... Replace.

Stator Check

To test the stator or diode, you must separate them by unsoldering the connecting wires.

CAUTION:

Use only as much heat as required to melt solder. Otherwise, diodes will be damaged by excessive heat.

1. Continuity test
 - No continuity ... Replace stator.
2. Ground test
 - Continuity exists ... Replace stator.

Diode Check

MAIN DIODES

- Use an ohmmeter to check condition of diodes as indicated in chart below.
- If any of the test results is not satisfactory, replace diode assembly.

	Ohmmeter probes		Continuity
	Positive ⊕	Negative ⊖	
Diodes check (Positive side)	Positive diode plate	Diode terminals	Yes
	Diode terminals	Positive diode plate	No
Diodes check (Negative side)	Negative diode plate	Diode terminals	No
	Diode terminals	Negative diode plate	Yes

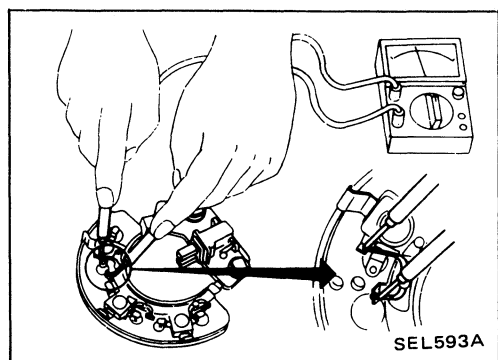
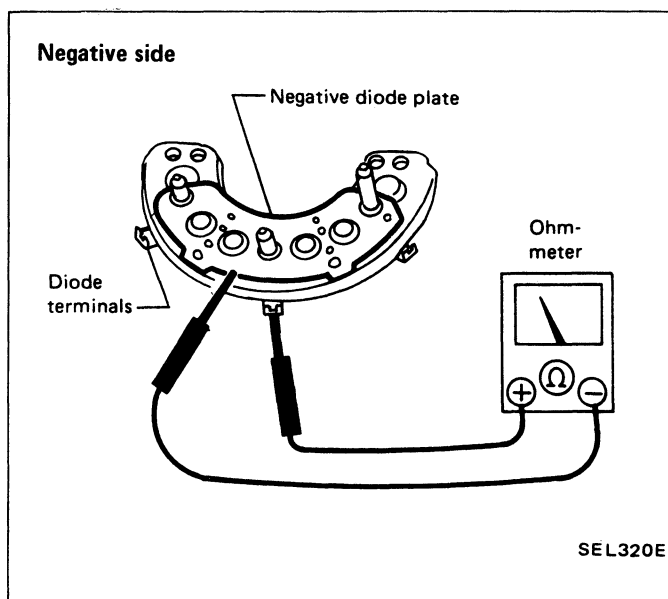
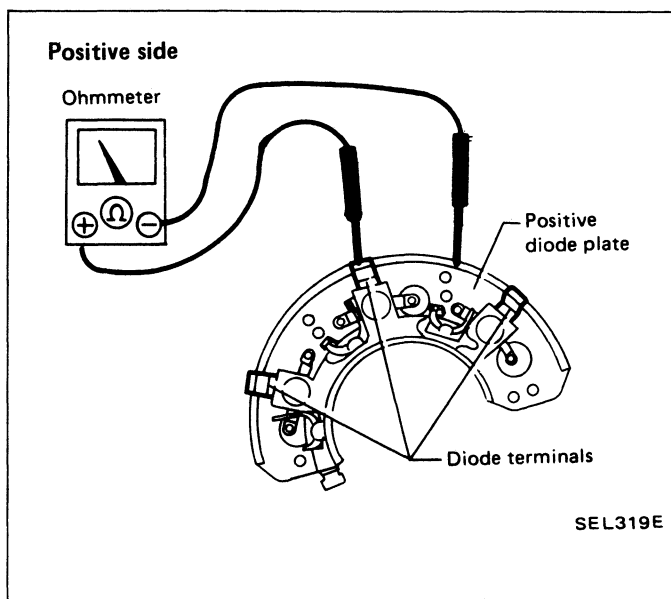

SUB-DIODES

- Attach ohmmeter's probe to each end of diode to check for continuity.
- Continuity is N.G. ... Replace diode assembly.

Assembly

Carefully observe the following instructions.

- When soldering each stator coil lead wire to diode assembly terminal, carry out the operation as fast as possible.

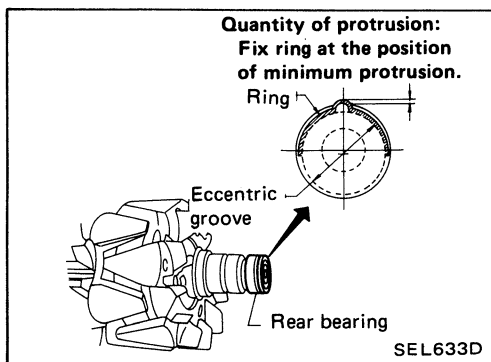
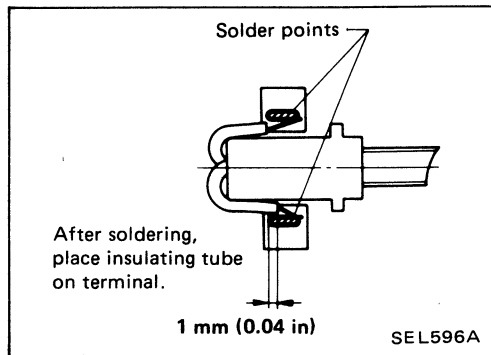
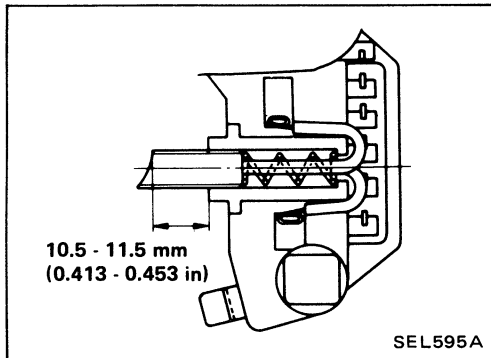

WHEN SOLDERING BRUSH LEAD WIRE

- (1) Position brush so that it extends 10.5 - 11.5 mm (0.413 - 0.453 in) from brush holder.

- (2) Coil lead wire 1.5 times around terminal groove. Solder outside of terminal.

When soldering, be careful not to let solder adhere to insulating tube as it will weaken the tube and cause it to break.

RING FITTING IN REAR BEARING

- Fix ring into groove in rear bearing so that it is as close to the adjacent area as possible.

CHARGING SYSTEM —Alternator—

Assembly (Cont'd)

REAR COVER INSTALLATION

- (1) Before installing front cover with pulley and rotor with rear cover, push brush up with fingers and retain brush by inserting brush lift wire into brush lift hole from outside.
- (2) After installing front and rear sides of alternator, pull brush lift wire by pushing toward center.

Do not pull brush lift wire toward outside of rear cover, as it will damage slip ring sliding surface.

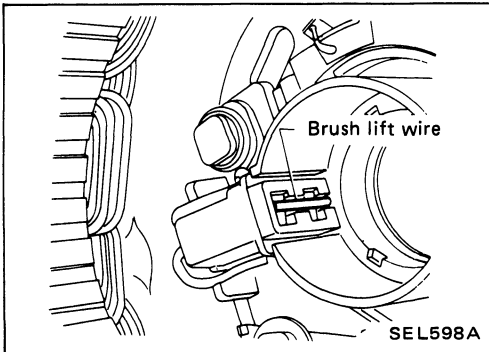
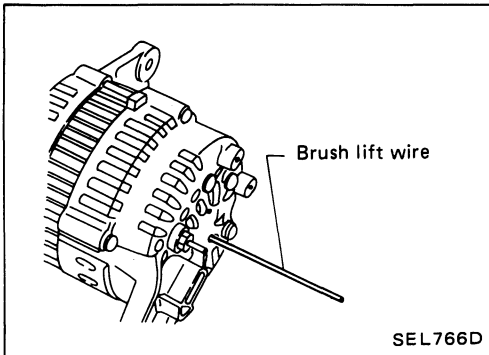

ALTERNATOR

Applied model	VG30i	Z24i			
		2WD	4WD	2WD	4WD
Applied area	All	U.S.A.		Canada	
Type	LR160-151	LR150-197B	LR150-194B	LR160-140B	LR160-154
Nominal rating	V-A	12-60	12-50	12-60	
Ground polarity	Negative				
Minimum revolution under no-load (When 14 volt is applied)	rpm	Less than 950 (When 13.5 volt is applied)	Less than 1,000		
Hot output current	A/rpm	More than 48/2,500 More than 58/5,000 (When 13.5 volts)	More than 40/2,500 More than 50/5,000	More than 50/2,500 More than 60/5,000	
Regulated output voltage	V	14.1 - 14.7	14.4 - 15.0		
Minimum length of brush	mm (in)	More than 6 (0.24)			
Brush spring pressure	N (g, oz)	1.471 - 3.432 (150 - 350, 5.29 - 12.34)	2.501 - 3.383 (255 - 345, 8.99 - 12.17)		1.471 - 3.432 (150 - 350, 5.29 - 12.34)
Slip ring minimum outer diameter	mm (in)	More than 30.6 (1.205).			

COMBINATION SWITCH

Check

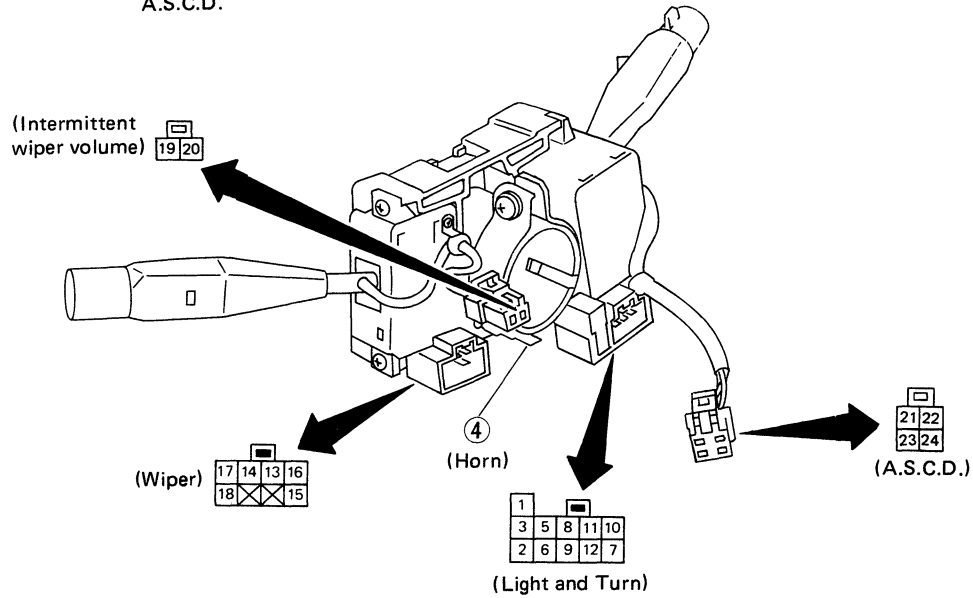
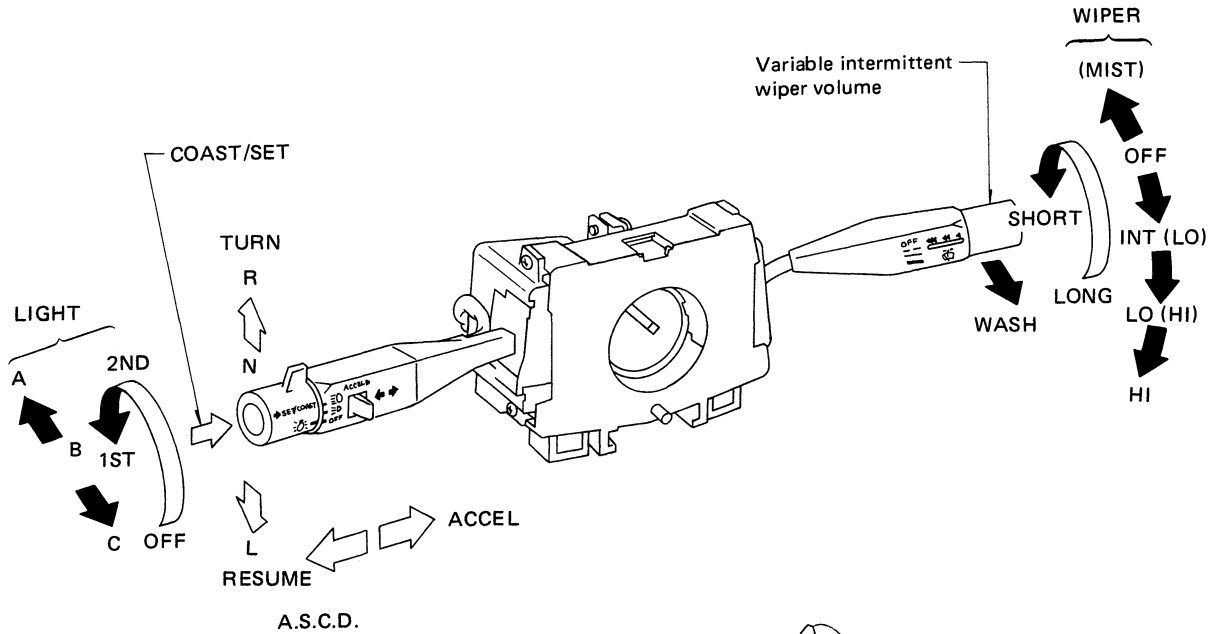

LIGHTING SWITCH

	OFF			1ST			2ND		
	A	B	C	A	B	C	A	B	C
5									
6									
7									
8									
9									
10									
11									
12									

WIPER SWITCH

	OFF	INT	LO	HI	WASH
13					
14					
15					
16					
17					
18					

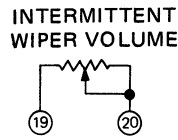

A.S.C.D. SET SWITCH

	COAST/SET	RESUME	ACCEL
21			
22			
23			
24			

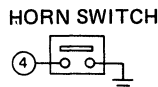

TURN SIGNAL SWITCH

	R	N	L
1			
2			
3			

	OFF	LO	HI	WASH
13				
14				
15				
16				
17				
18				

COMBINATION SWITCH

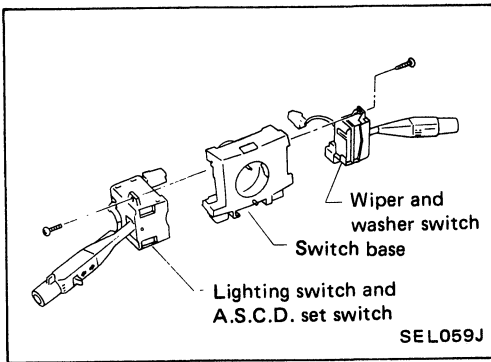

Replacement

- Lighting switch, wiper & washer switch and A.S.C.D. set switch can be replaced without removing combination switch base.

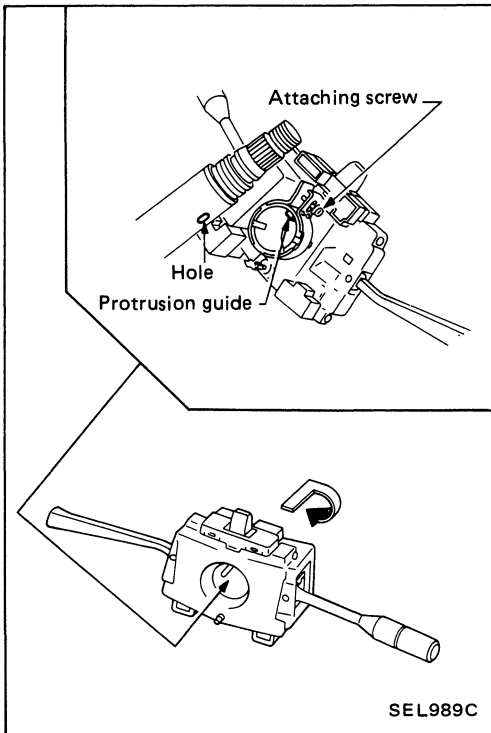

- To remove combination switch base, remove base attaching screw and turn after pushing on it.

HEADLAMP

Wiring Diagram

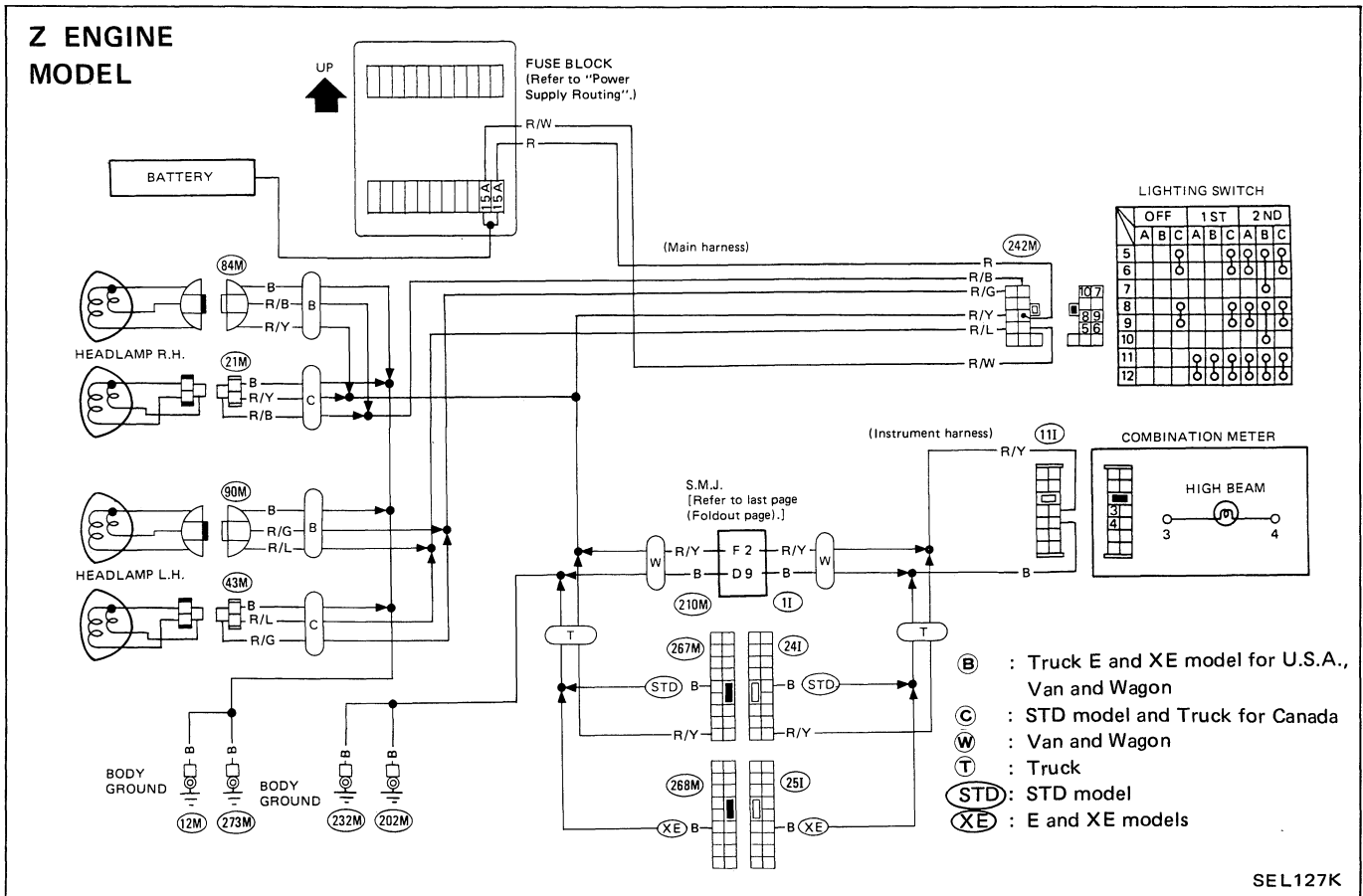
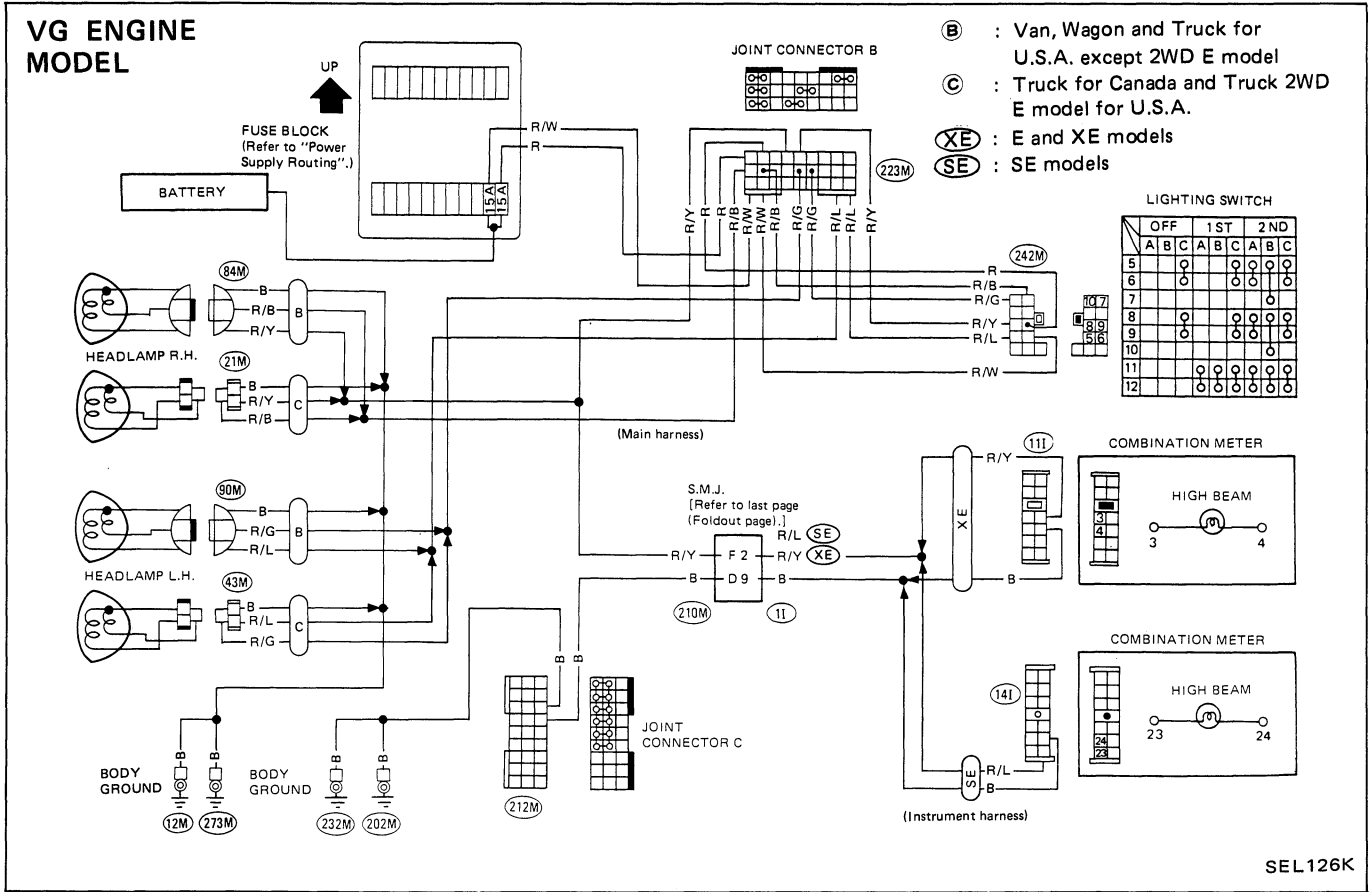

HEADLAMP

Aiming Adjustment

When performing headlamp aiming adjustment, use an aiming machine, aiming wall screen or headlamp tester. For operating instructions of any aimer, it should be in good repair, calibrated and used according to respective operation manuals supplied with the unit.

If any aimer is not available, aiming adjustment can be done as follows:

For details, refer to the regulations in your own country.

CAUTION:

- a. Keep all tires inflated to correct pressures.
- b. Place vehicle and tester on one and same flat surface.
- c. See that there is no load in vehicle (coolant, engine oil filled up to correct level and full fuel tank) other than the driver (or equivalent weight placed in driver's position).

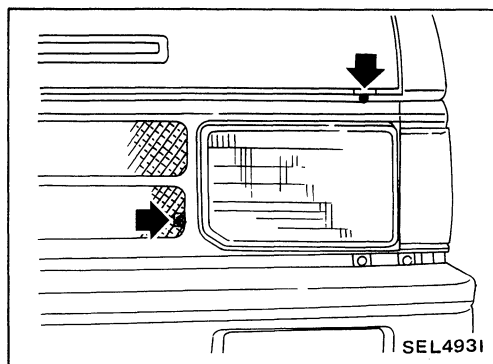

LOW BEAM

1. Turn headlamp low beam on.
2. Use adjusting screws to perform aiming adjustment.

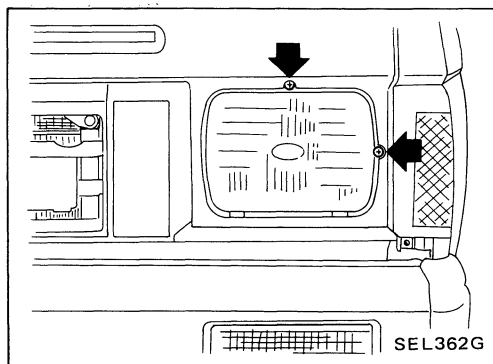

- Before adjusting headlamps, remove covers.
- First tighten the adjust screw all the way and then make adjustment by loosening the screw.

HEADLAMP

Aiming Adjustment (Cont'd)

- Adjust headlamps so that upper edge and left edge of high intensity zone are within the acceptable range as shown at left.
- Dotted lines in illustration show center of headlamp.

"H": Horizontal center line of headlamps

"WL": Distance between each headlamp center

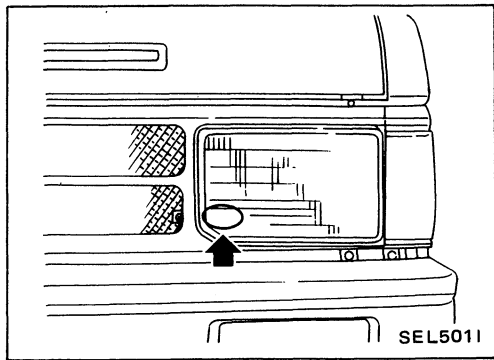
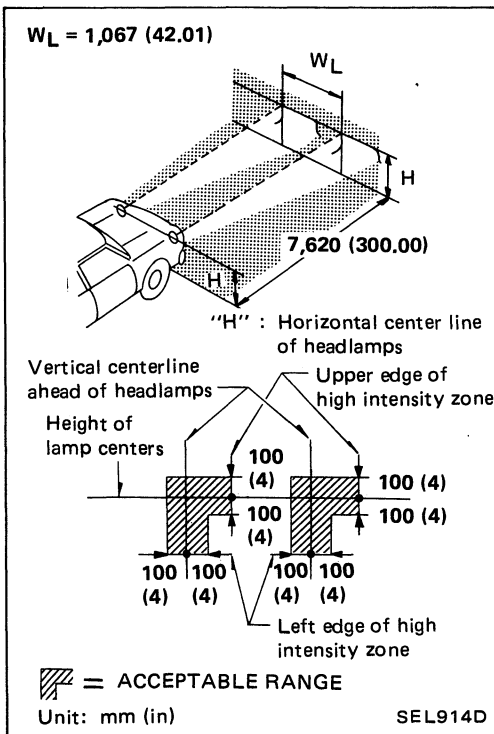

When using a mechanical aimer, adjust adapter legs to the data marked on the headlamps.

Example:

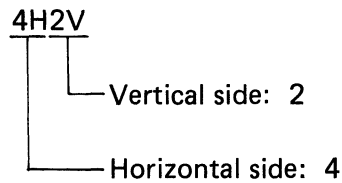

EXTERIOR LAMP

Clearance, License, Tail and Stop Lamps/Wiring Diagram

TRUCK MODEL

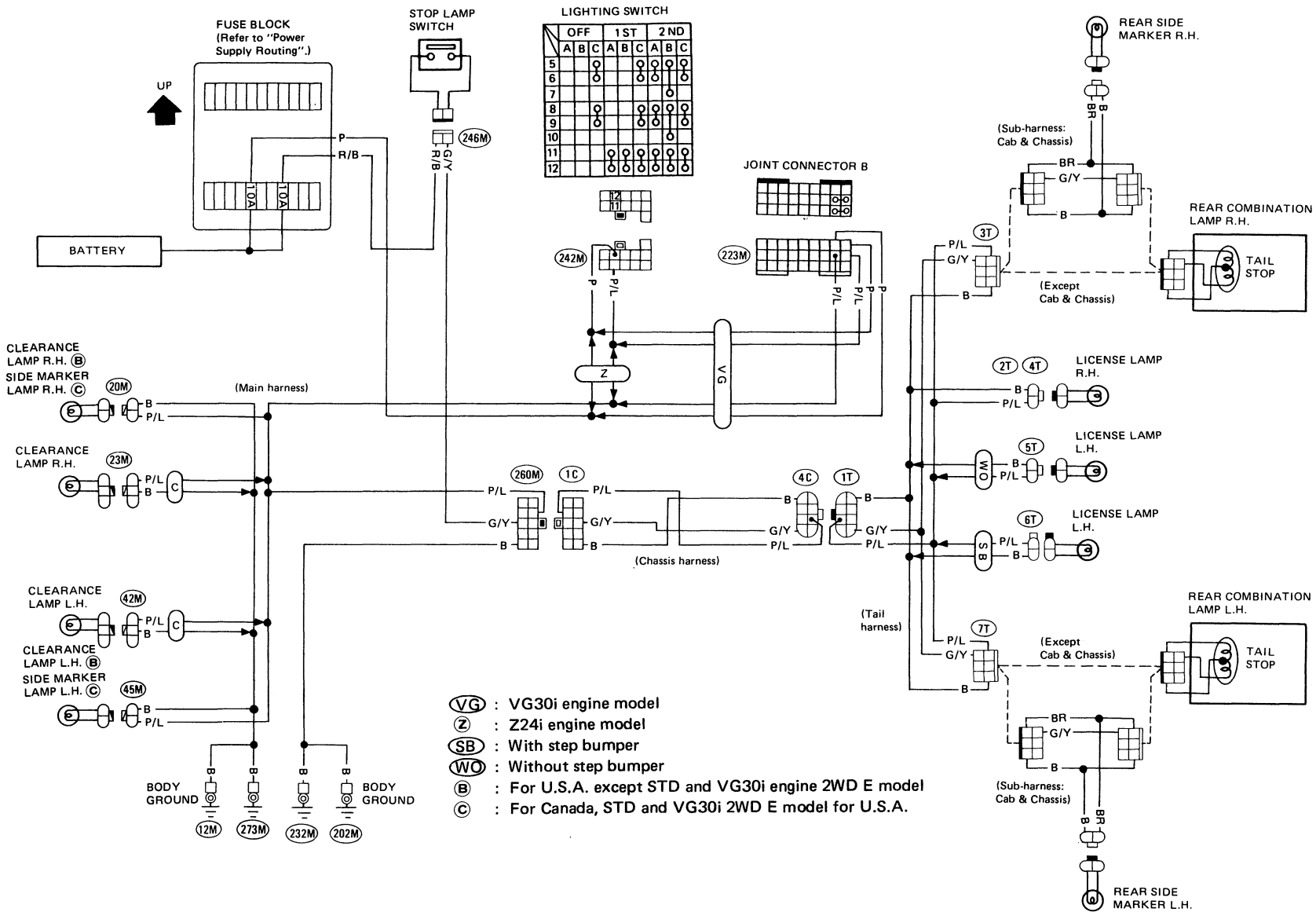

EL-43

SEL128K

EXTERIOR LAMP

Clearance, License, Tail and Stop Lamps/Wiring Diagram (Cont'd)

VAN AND WAGON MODEL

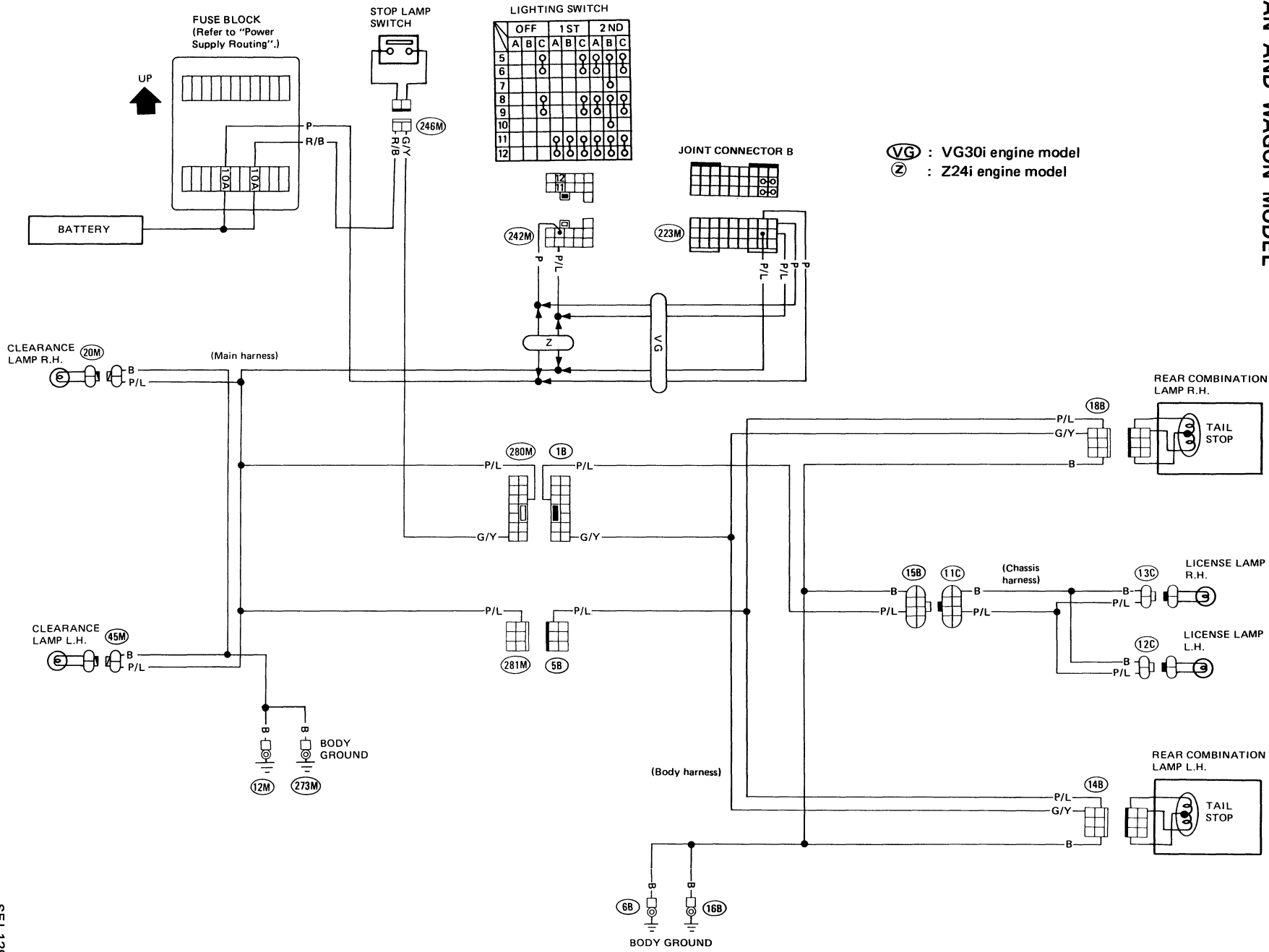

EL-44

SEL129K

EXTERIOR LAMP

Back-up Lamp/Wiring Diagram

M/T MODEL

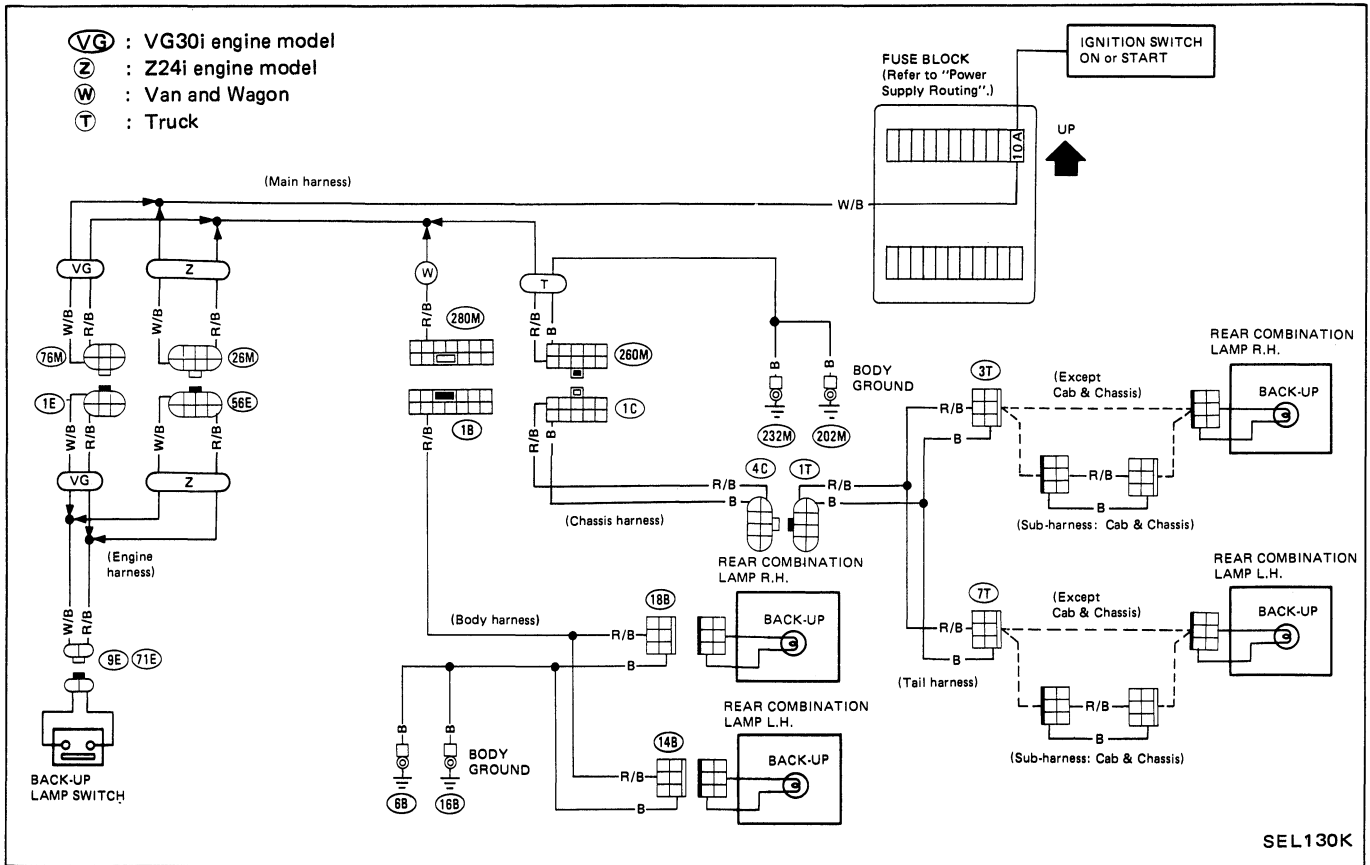

2WD A/T MODEL

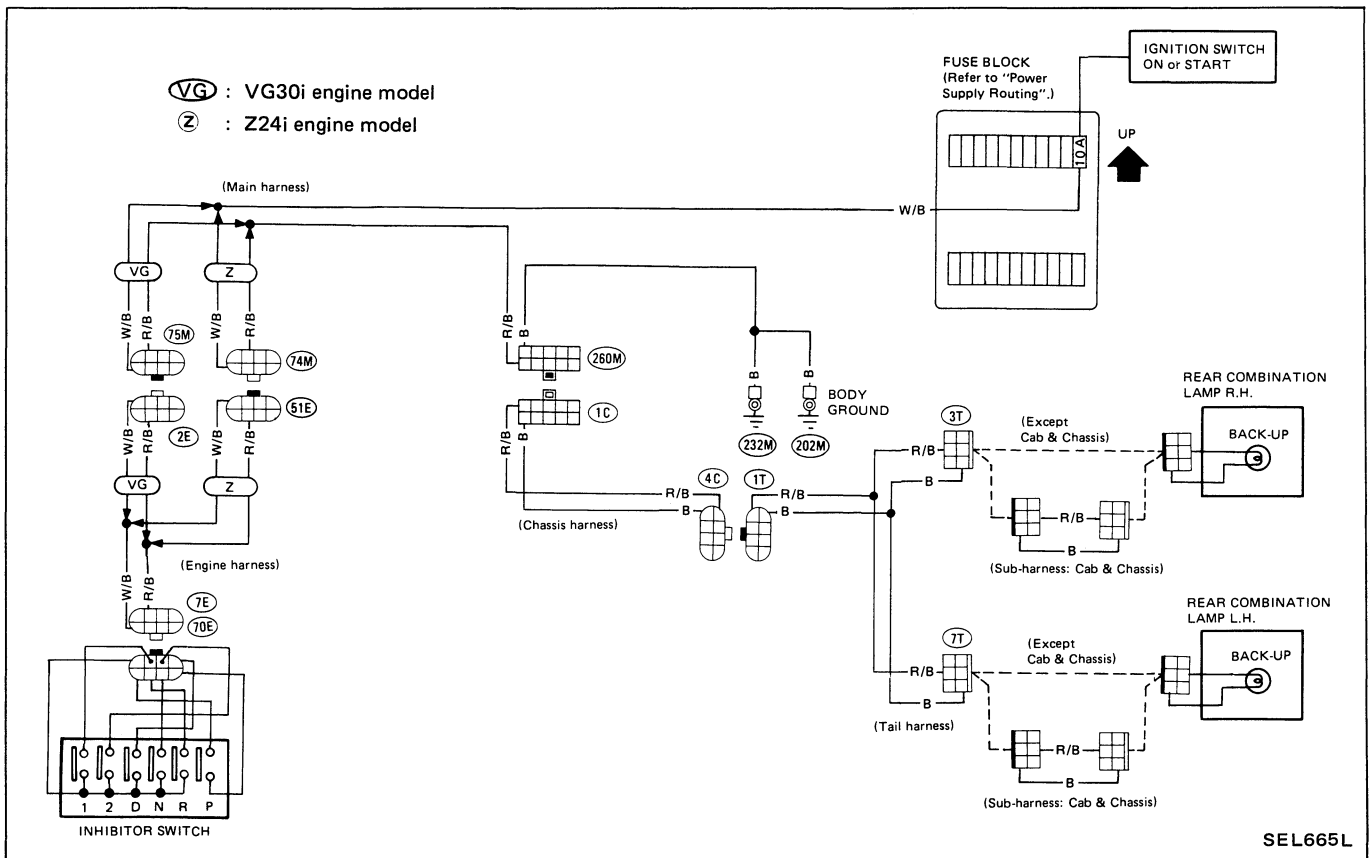

EXTERIOR LAMP

Back-up Lamp/Wiring Diagram (Cont'd)

4WD A/T MODEL

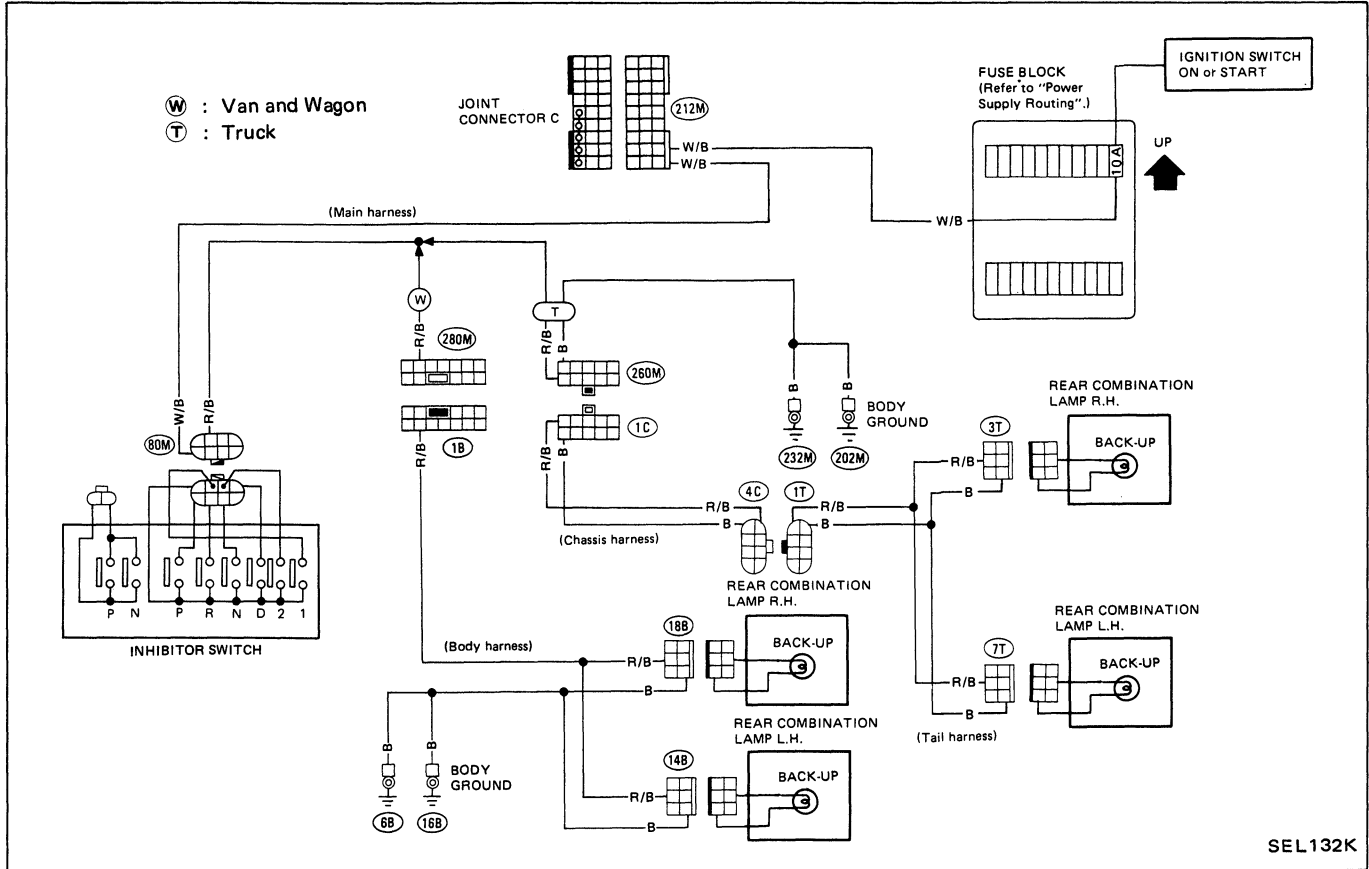

SEL132K

Turn Signal and Hazard Warning Lamps/Wiring Diagram

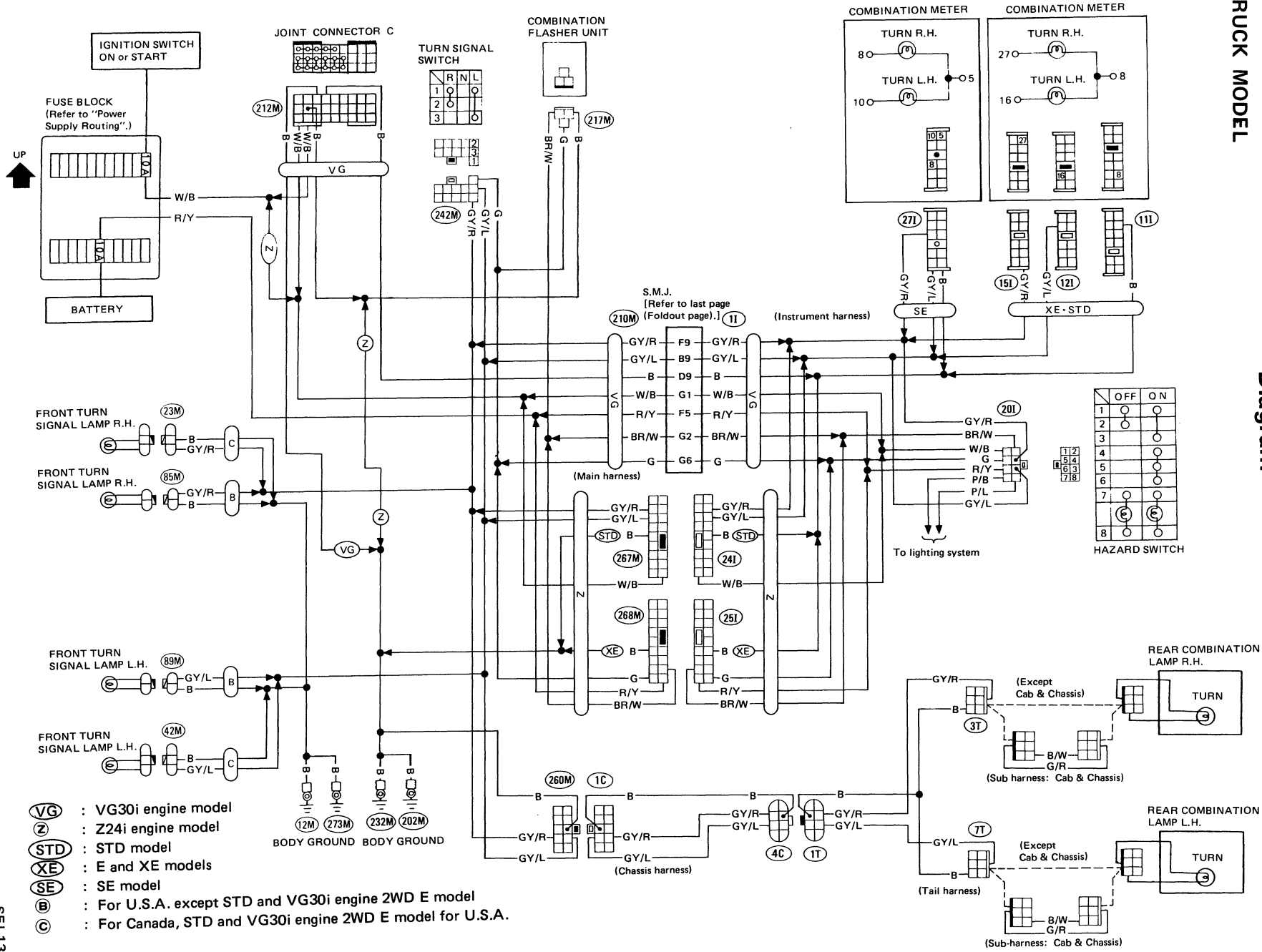

	OFF	ON
1	<input type="checkbox"/>	<input type="checkbox"/>
2	<input type="checkbox"/>	<input type="checkbox"/>
3	<input type="checkbox"/>	<input type="checkbox"/>
4	<input type="checkbox"/>	<input type="checkbox"/>
5	<input type="checkbox"/>	<input type="checkbox"/>
6	<input type="checkbox"/>	<input type="checkbox"/>
7	<input type="checkbox"/>	<input type="checkbox"/>
8	<input type="checkbox"/>	<input type="checkbox"/>

HAZARD SWITCH

- VG** : VG30i engine model
- Z** : Z24i engine model
- STD** : STD model
- XE** : E and XE models
- SE** : SE model
- B** : For U.S.A. except STD and VG30i engine 2WD E model
- C** : For Canada, STD and VG30i engine 2WD E model for U.S.A.

EL-47

SEL 133K

EXTERIOR LAMP

Turn Signal and Hazard Warning Lamps/Wiring Diagram (Cont'd)

VAN AND WAGON MODEL

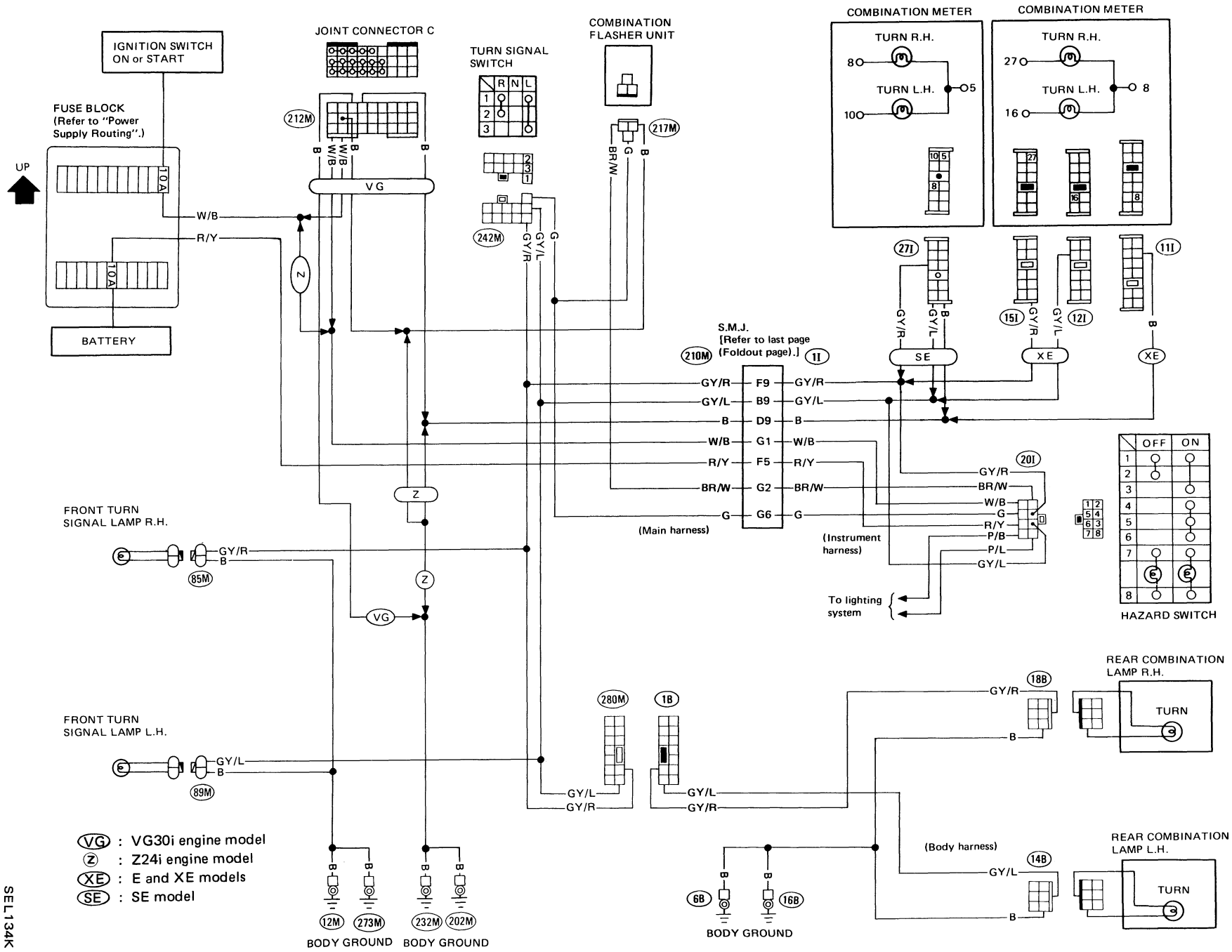

EL-48

SEL134K

EXTERIOR LAMP

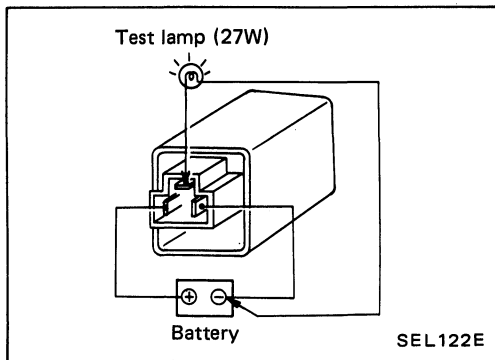

Combination Flasher Unit Check

- Before checking, ensure that bulbs meet specifications.
- Connect a battery and test lamp to the combination flasher unit, as shown. Combination flasher unit is properly functioning if it blinks when power is supplied to the circuit.

Bulb Specifications

HEADLAMPS

	Wattage (W)	Bulb No.
Conventional bulb	65/55	H6052
Halogen bulb	65/35	H6054

OTHER LAMPS

	Wattage (W)	Bulb No.
Front combination lamp		
Turn signal/clearance	27/8	1157
Front side marker lamp	3.8	194
Rear combination lamp		
Turn signal	27	1156
Stop/Tail	27/8	1157
Back-up	27	1156
Rear side marker lamp	3.4	158
License plate lamp	5	194
Interior lamp	10	—

EXCEPT TRUCK WITH Z24i ENGINE

Illumination/Wiring Diagram

- (VG) : VG30i engine model
- (Z) : Z24i engine model
- (T) : Truck
- (W) : Van and Wagon
- (XE) : E and XE models
- (SE) : SE models
- (CS) : Column shift model
- (FS) : Floor shift model

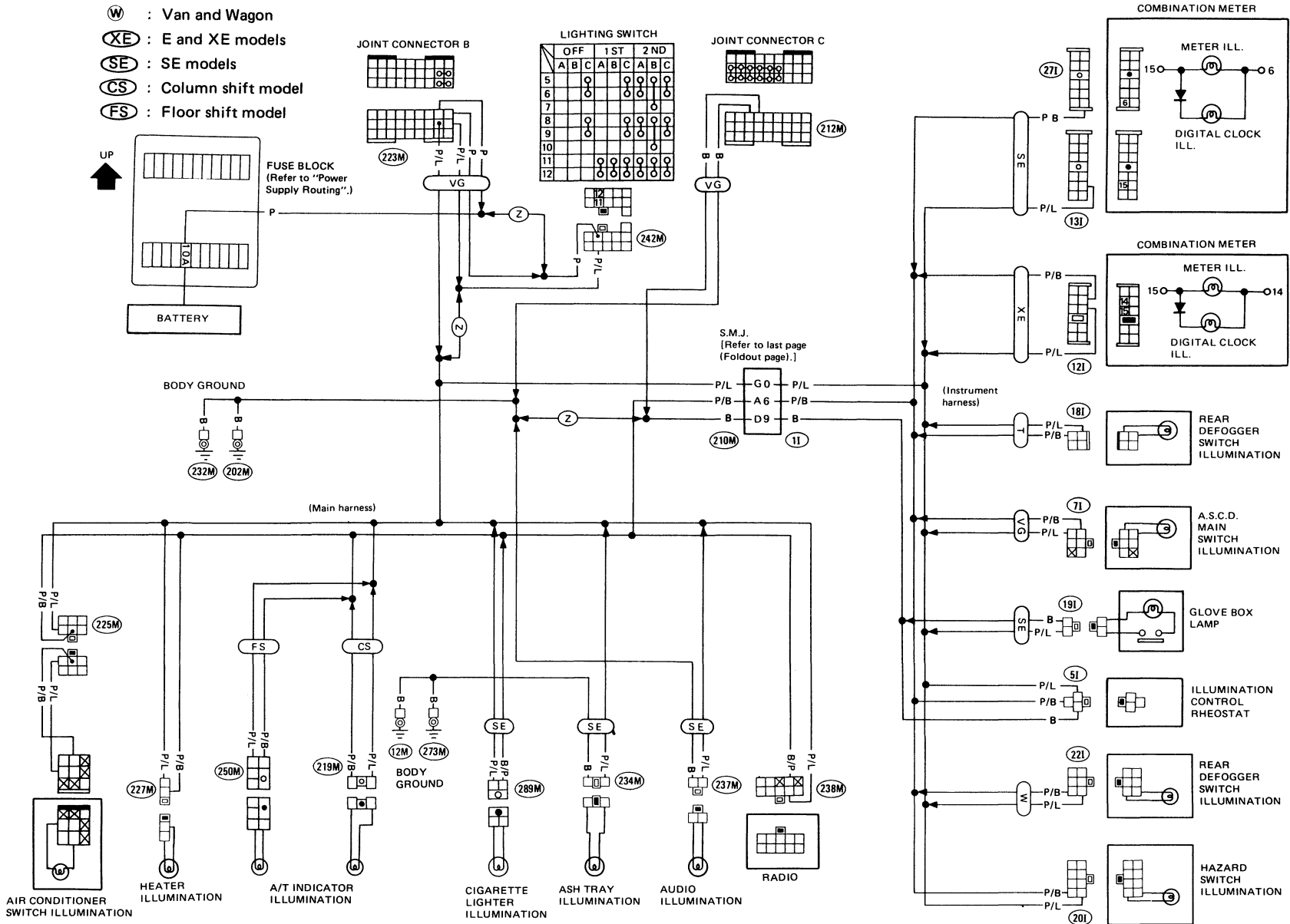

INTERIOR LAMP
Illumination/Wiring Diagram (Cont'd)

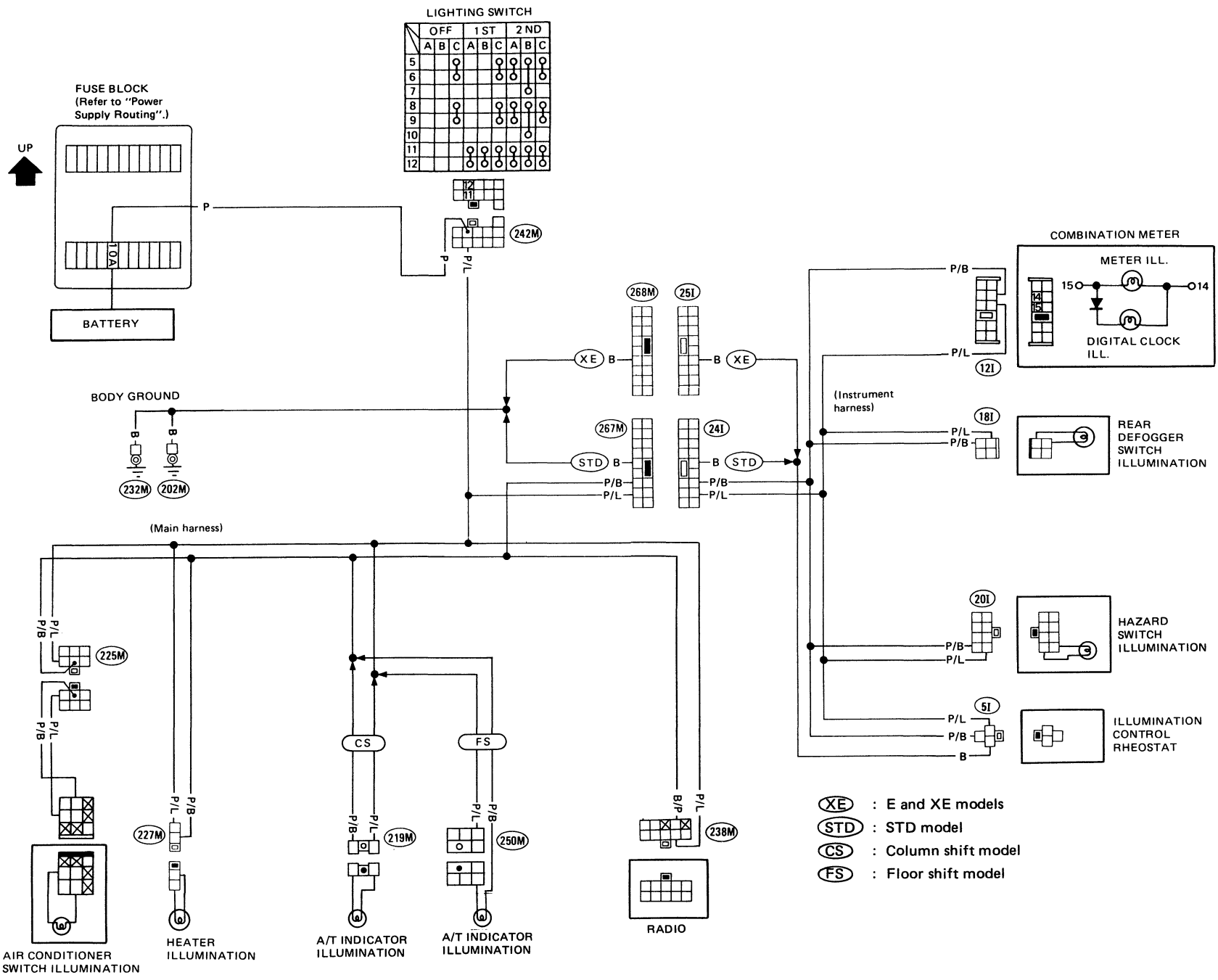

EL-51

SEL667L

INTERIOR LAMP

Interior Lamp/Wiring Diagram

TRUCK MODEL

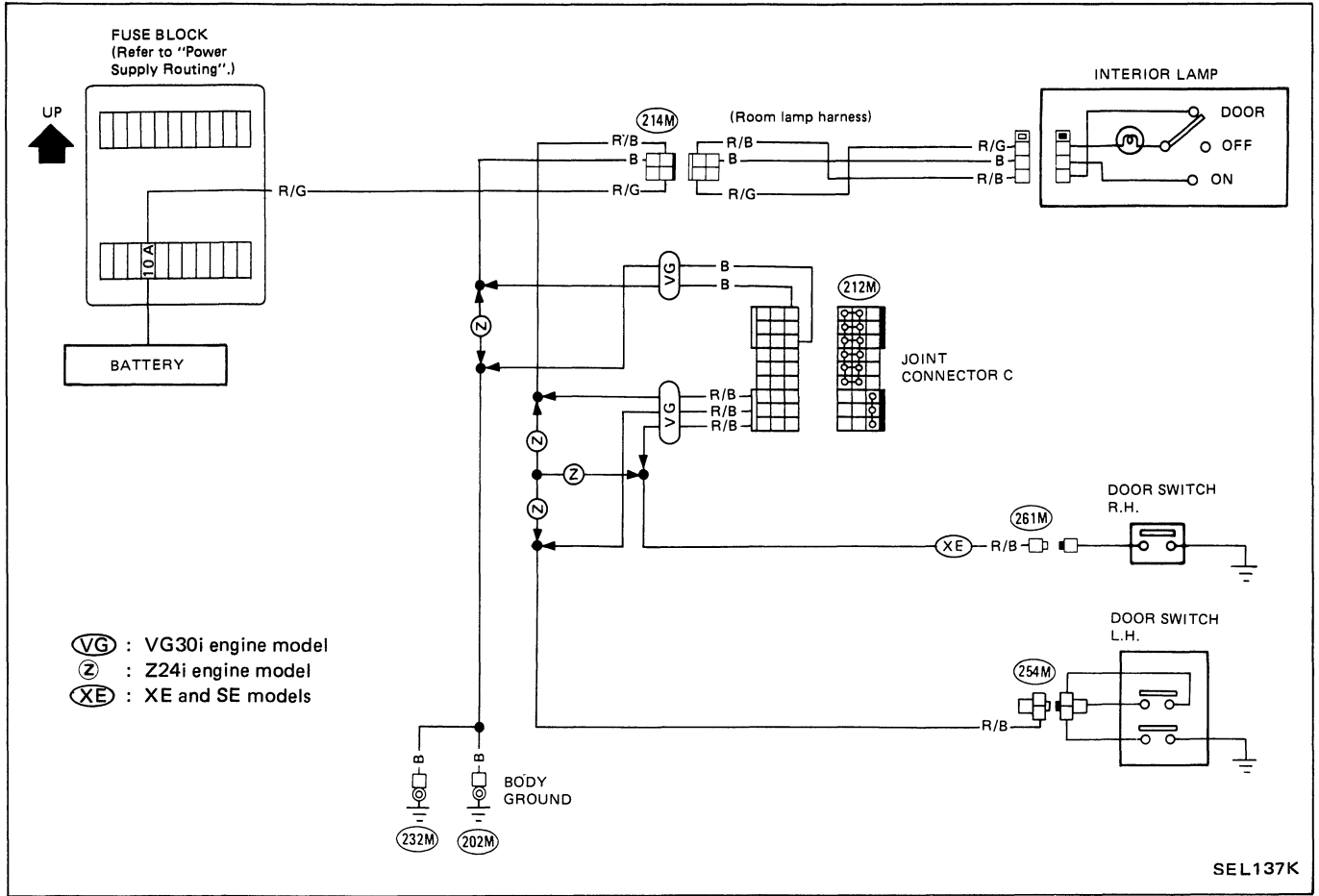

METER AND GAUGES

Combination Meter

SE MODEL

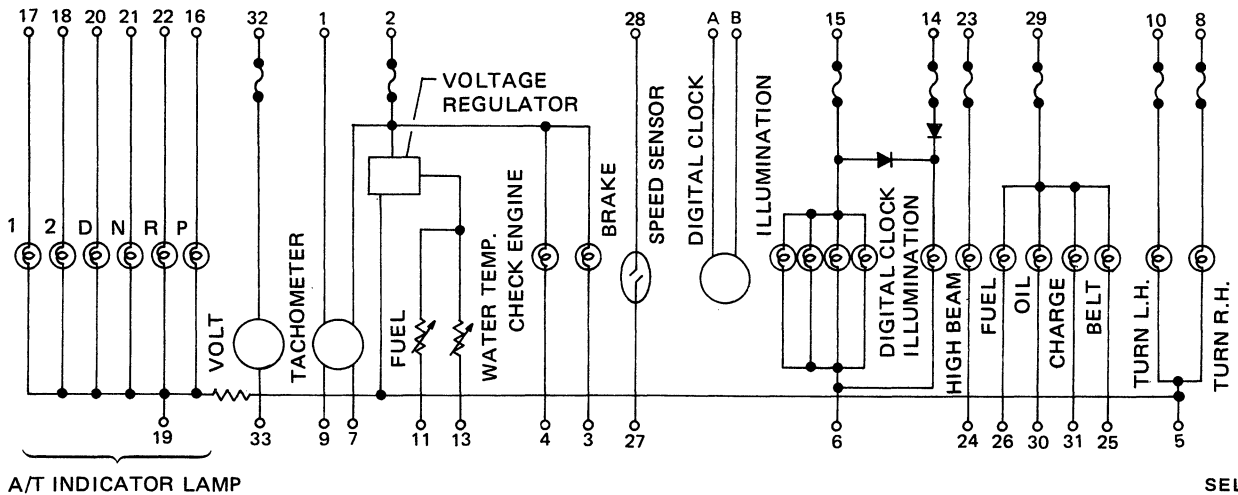
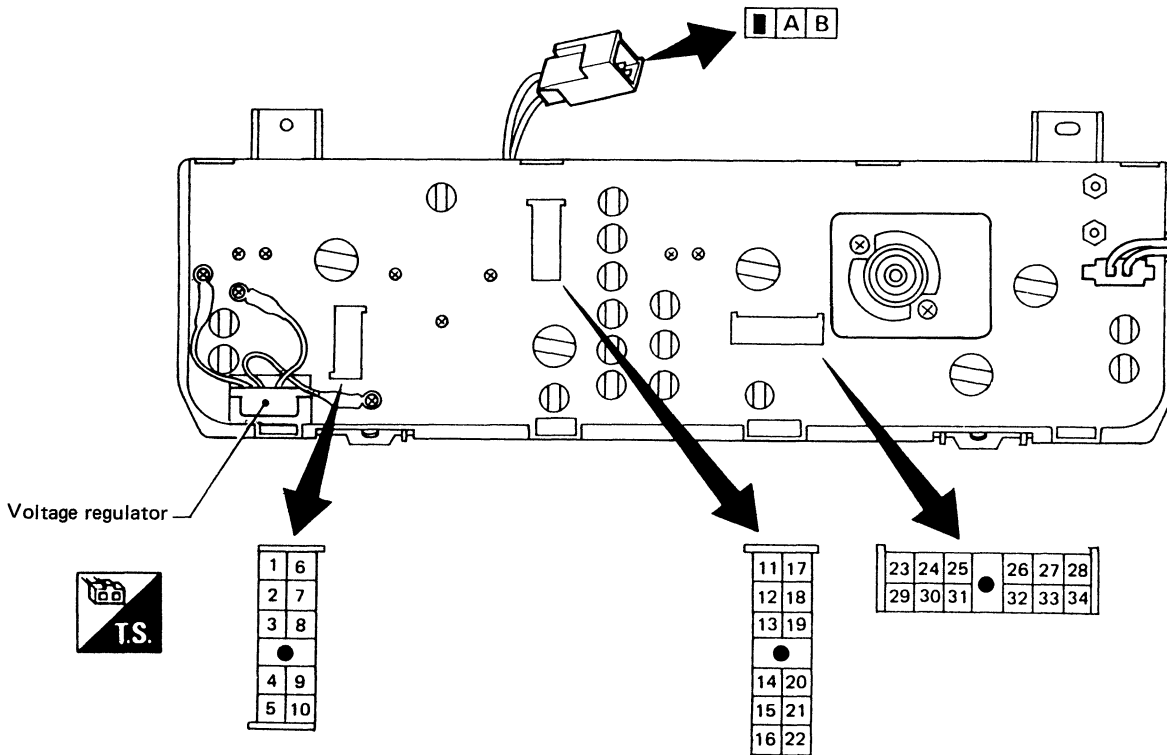
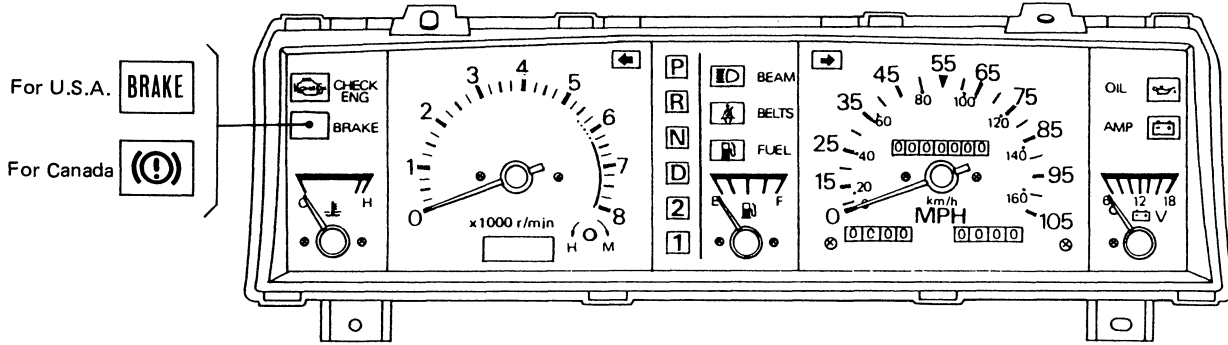

A/T INDICATOR LAMP

SEL668L

METER AND GAUGES

Combination Meter (Cont'd)

STD, E AND XE MODEL

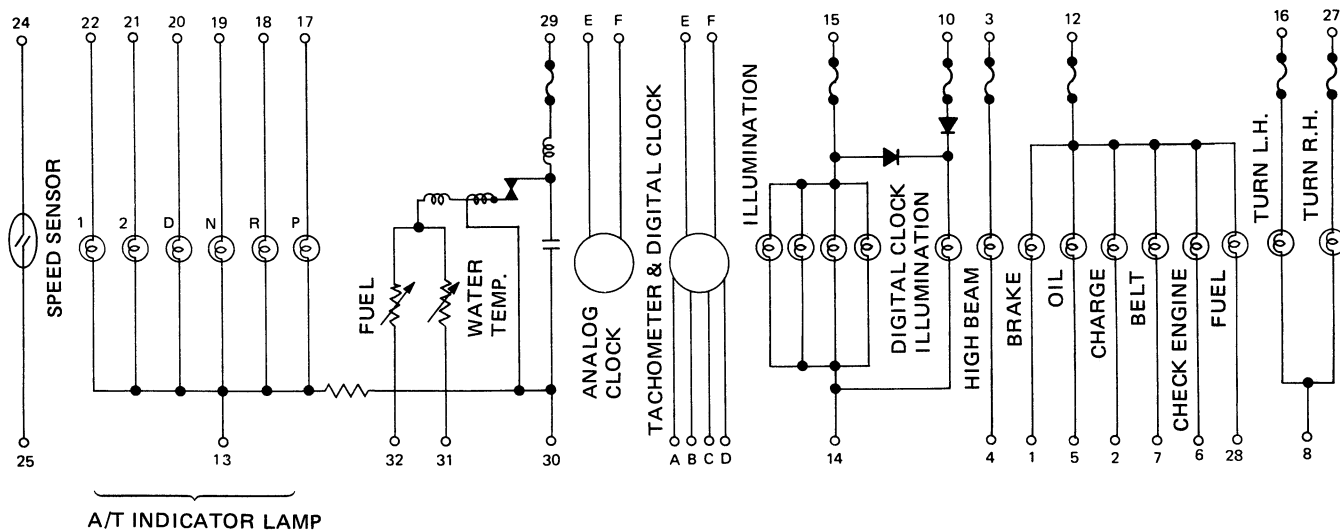
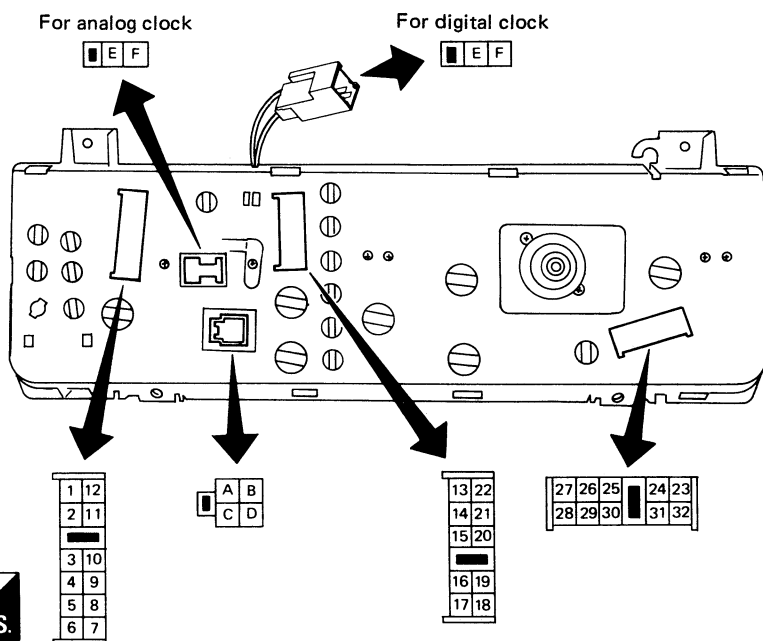
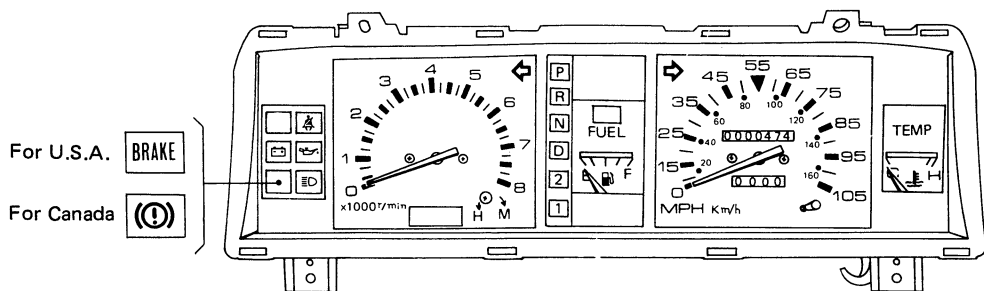

SEL669L

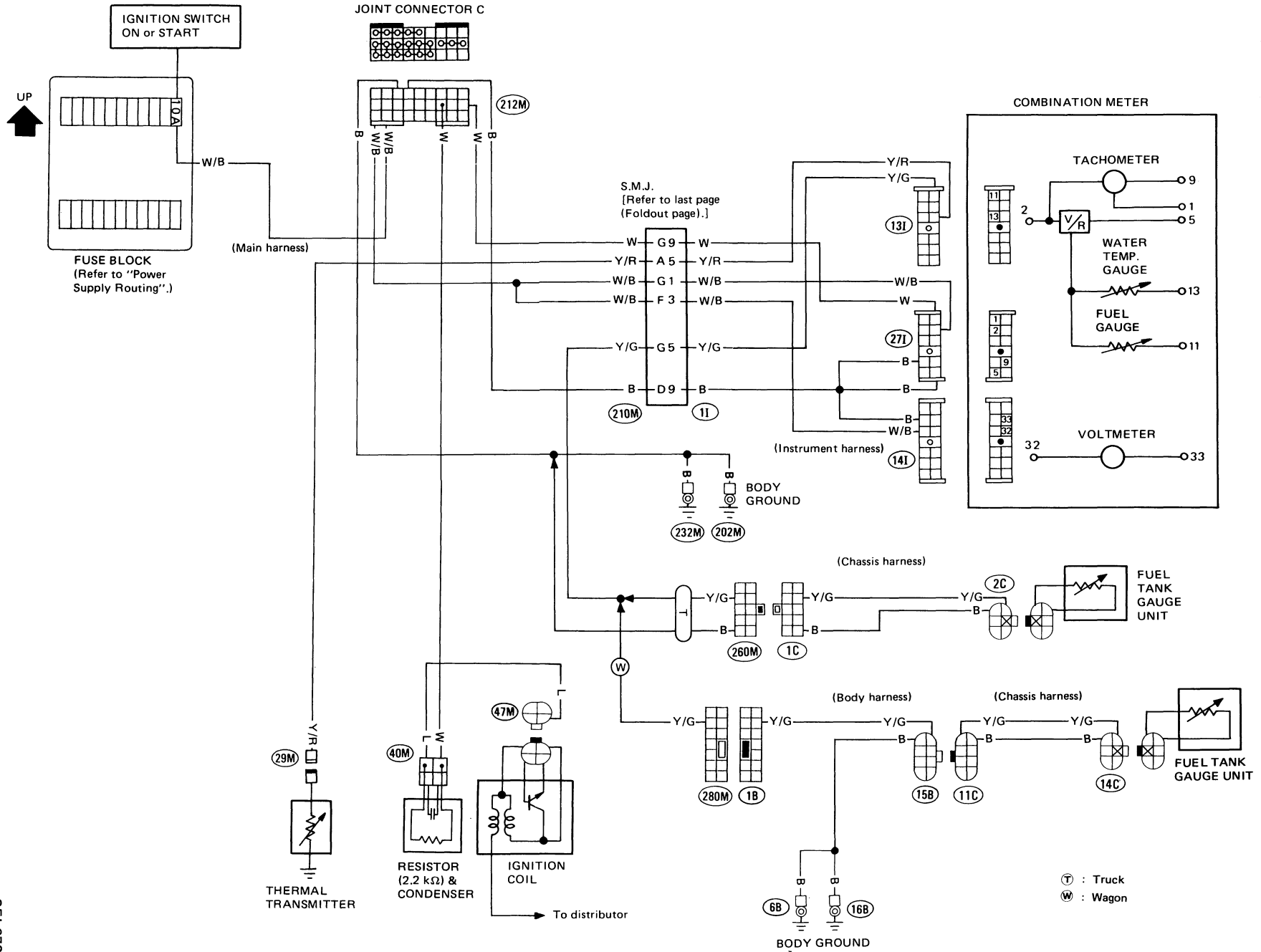

SE MODEL

Wiring Diagram

METER AND GAUGES

Ⓣ : Truck
 Ⓜ : Wagon

- (VG) : VG30i engine model
- (Z) : Z24i engine model
- (A) : A/T model

- (M) : M/T model
- (STD) : STD model
- (E) : E and XE models

- (XE) : XE models
- (T) : Truck
- (W) : Van and Wagon
- (B) : Z24i engine Truck models
- (C) : Van, Wagon and VG30i engine Truck models

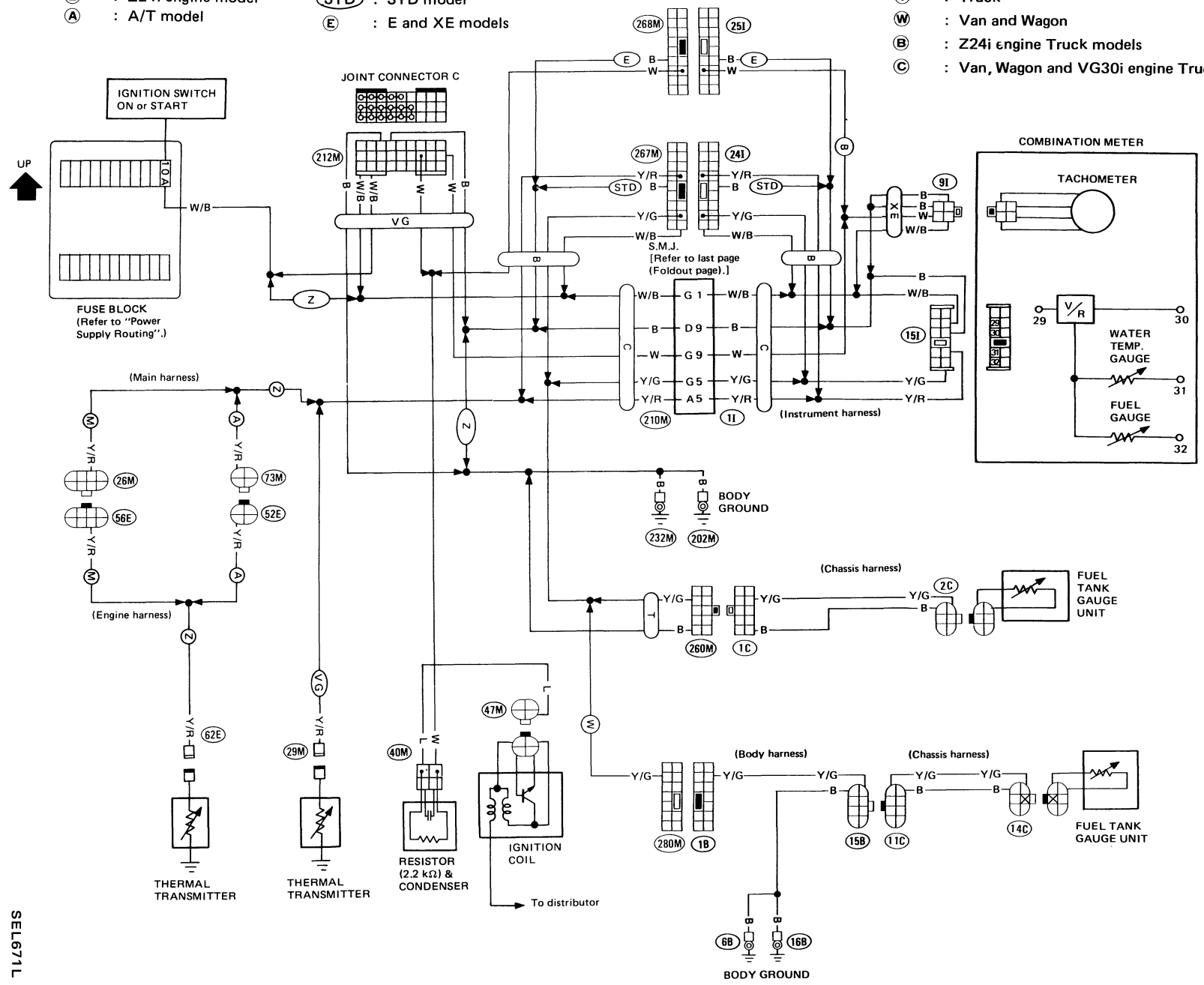

EL-57

SEL671L

METER AND GAUGES

Inspection/Fuel Gauge and Water Temperature Gauge

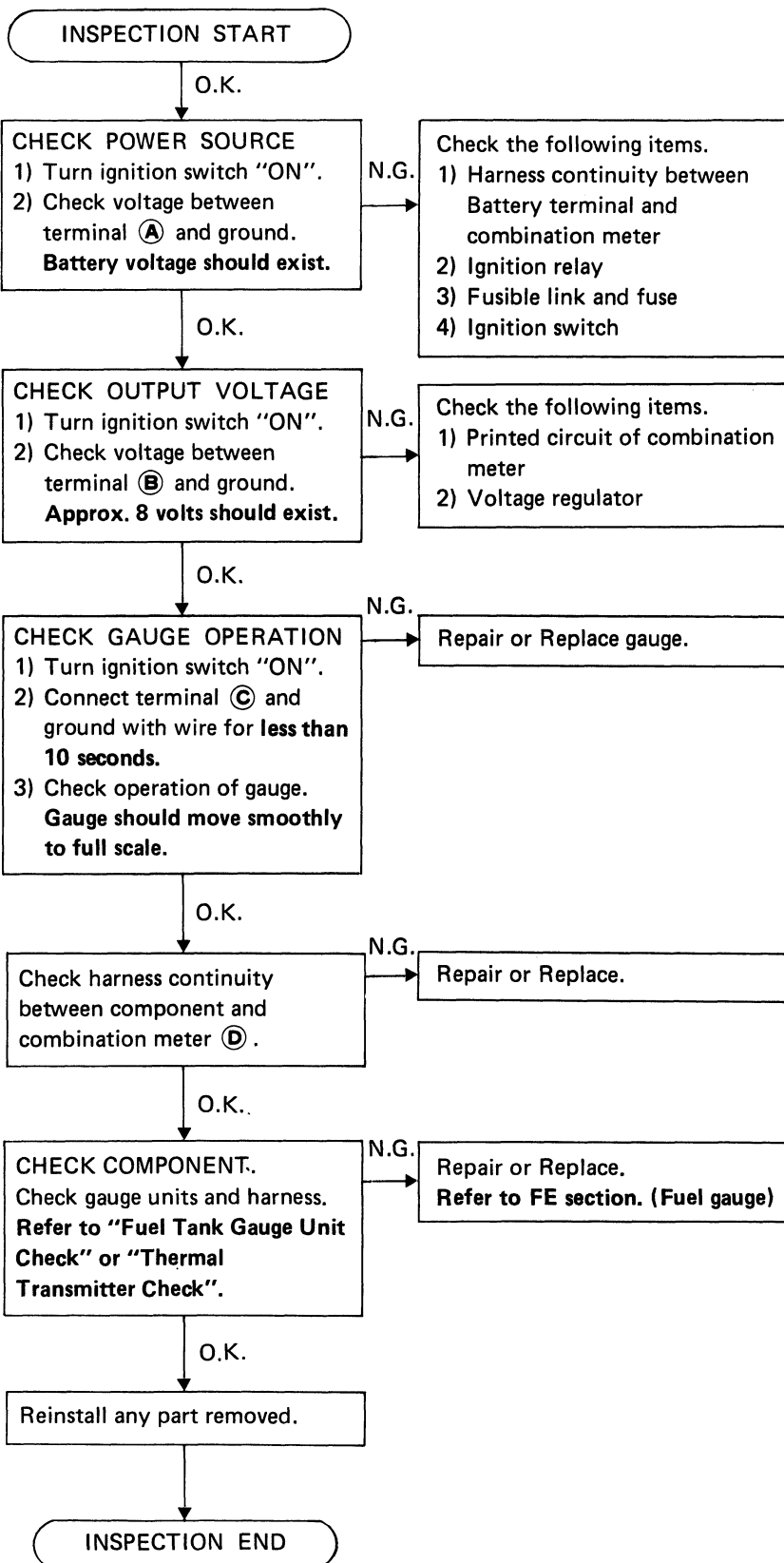
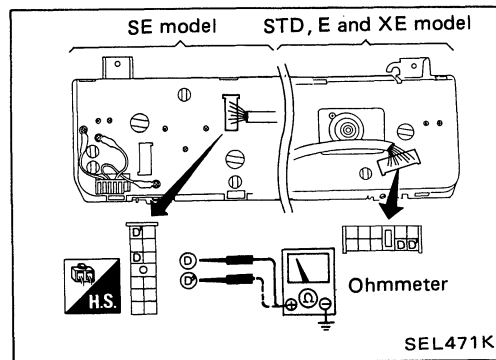
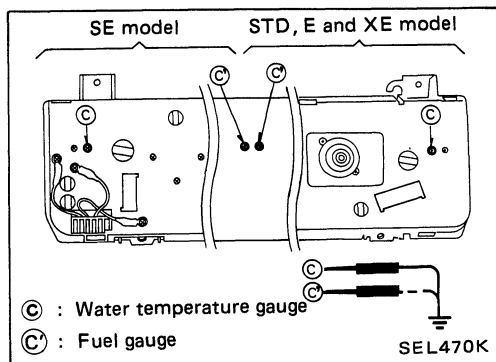
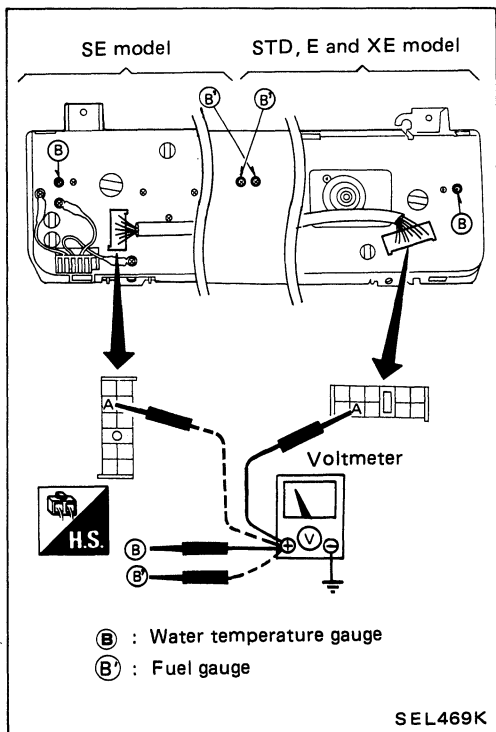

METER AND GAUGES

Fuel Tank Gauge Unit Check

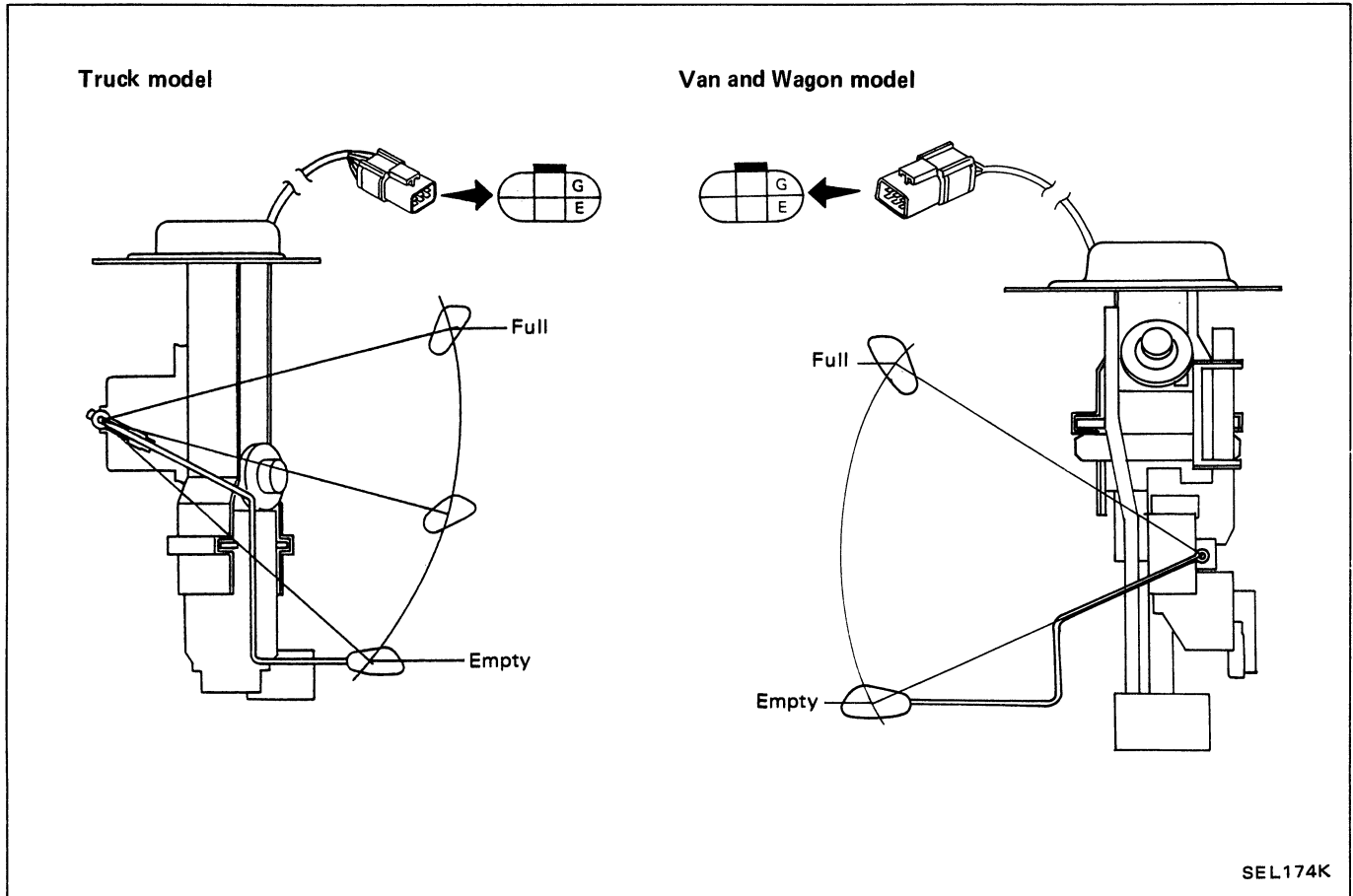

Ohmmeter (+) (-)		Model	Float position	Resistance value
ⓐ	ⓔ	Truck	Full	Approx. 3.8 - 8.5Ω
			Empty	Approx. 83.6 - 93.6Ω
		Van and Wagon	Full	Approx. 6.7 - 8.5Ω
			Empty	Approx. 86.6 - 93.7Ω

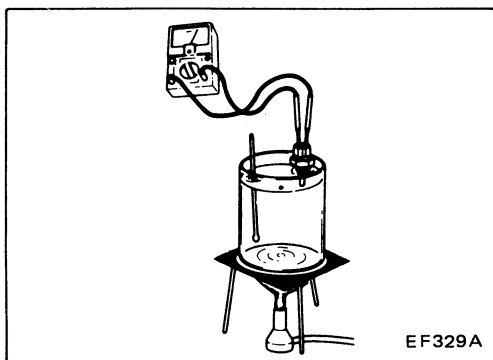

Thermal Transmitter Check

Check the resistance between the terminals of thermal transmitter and body ground.

Water temperature	Resistance
60°C (140°F)	Approx. 70 - 90Ω
100°C (212°F)	Approx. 21 - 24Ω

METER AND GAUGES

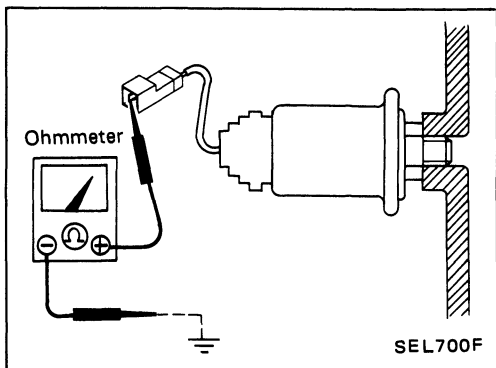

Oil Pressure Switch Check

Check the continuity between the terminals of oil pressure switch and body ground.

Oil pressure kPa (kg/cm ² , psi)	Operation
More than 10 - 20 (0.1 - 0.2, 1.4 - 2.8)	ON
Less than 10 - 20 (0.1 - 0.2, 1.4 - 2.8)	OFF

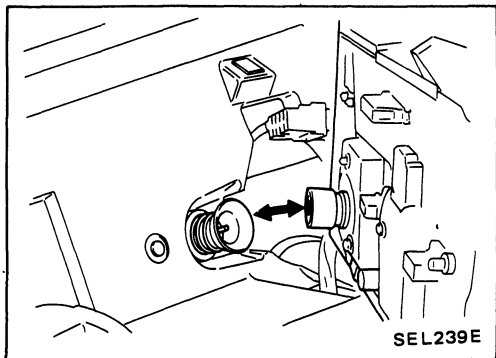

Speedometer Cable Removal and Installation

Combination meter and speedometer cable can be joined together simply by inserting combination meter.

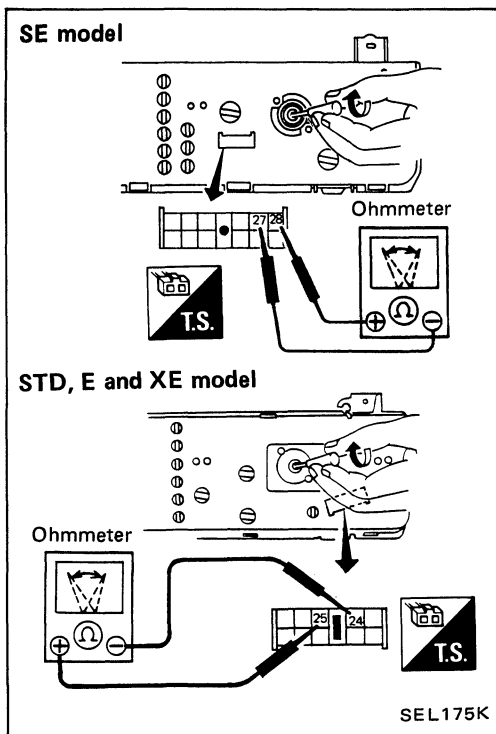

Speed Sensor Signal Check

- A speed sensor is built into the speedometer.
1. Turn speedometer slowly using a small screwdriver.
 2. Check continuity of speed sensor circuit.
- Continuity exists two times for each turn ... O.K.

WARNING LAMPS AND CHIME

A/T Indicator Lamp/Wiring Diagram

2WD MODEL

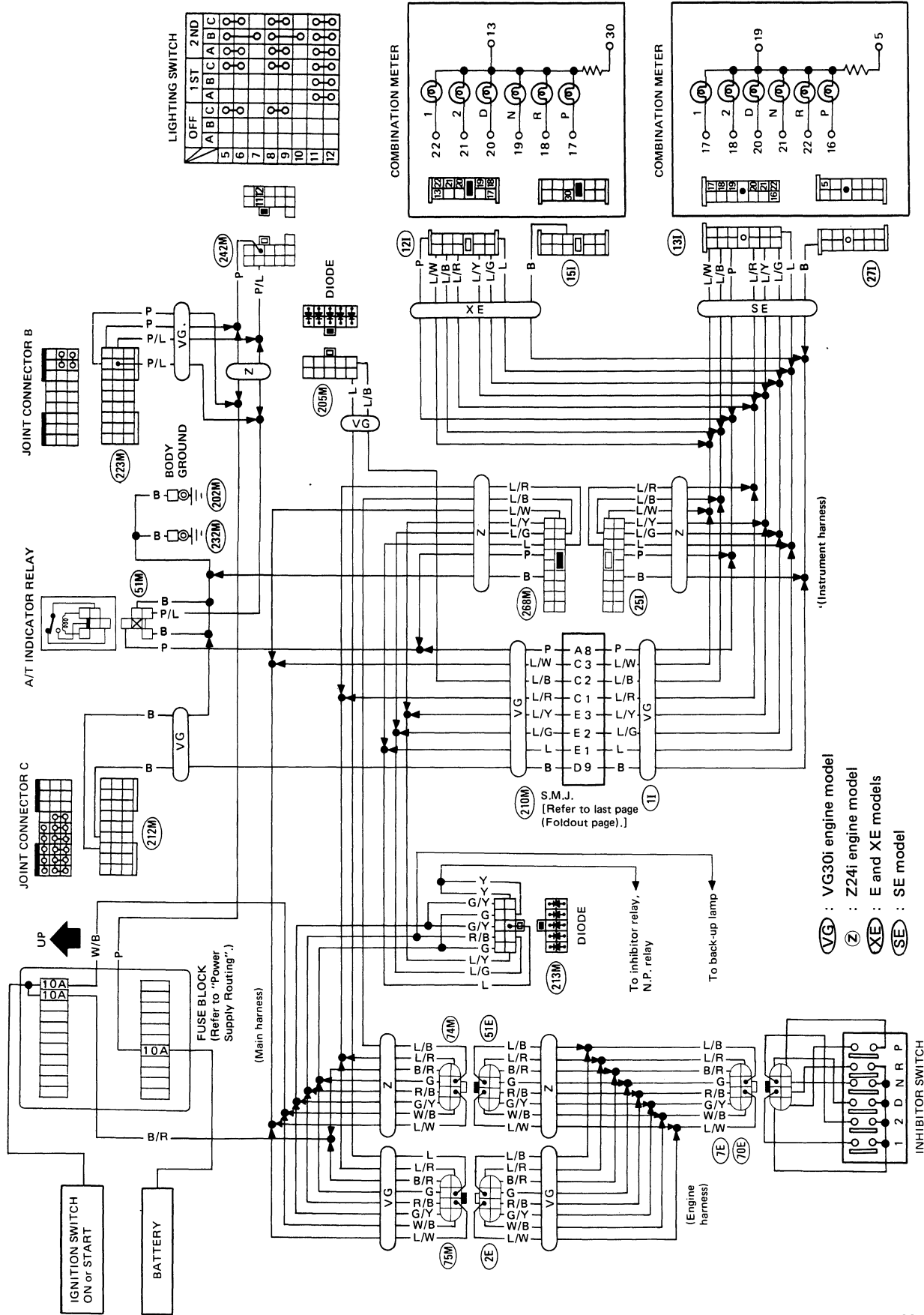

WARNING LAMPS AND CHIME

Warning Lamps/Schematic

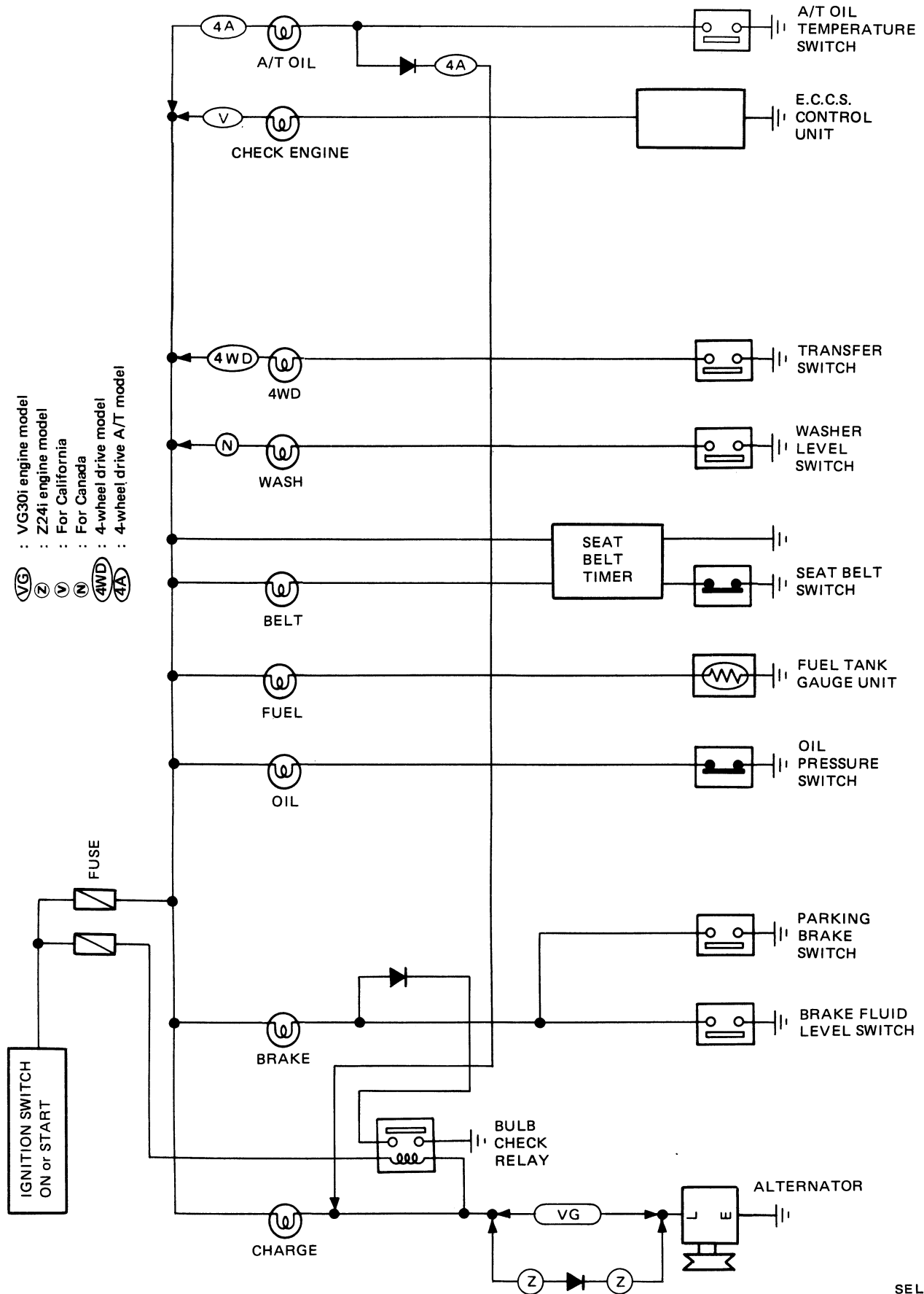

SEL145K

WARNING LAMPS AND CHIME

Warning Lamps/Wiring Diagram

SE MODEL

- Ⓣ : Truck
- Ⓦ : Van and Wagon
- Ⓐ : A/T model
- Ⓜ : M/T model
- ⓈⓂⓃ : 4-wheel drive model
- ⓈⓂⓃⒶ : 4-wheel drive A/T model
- Ⓥ : For California
- Ⓝ : For Canada

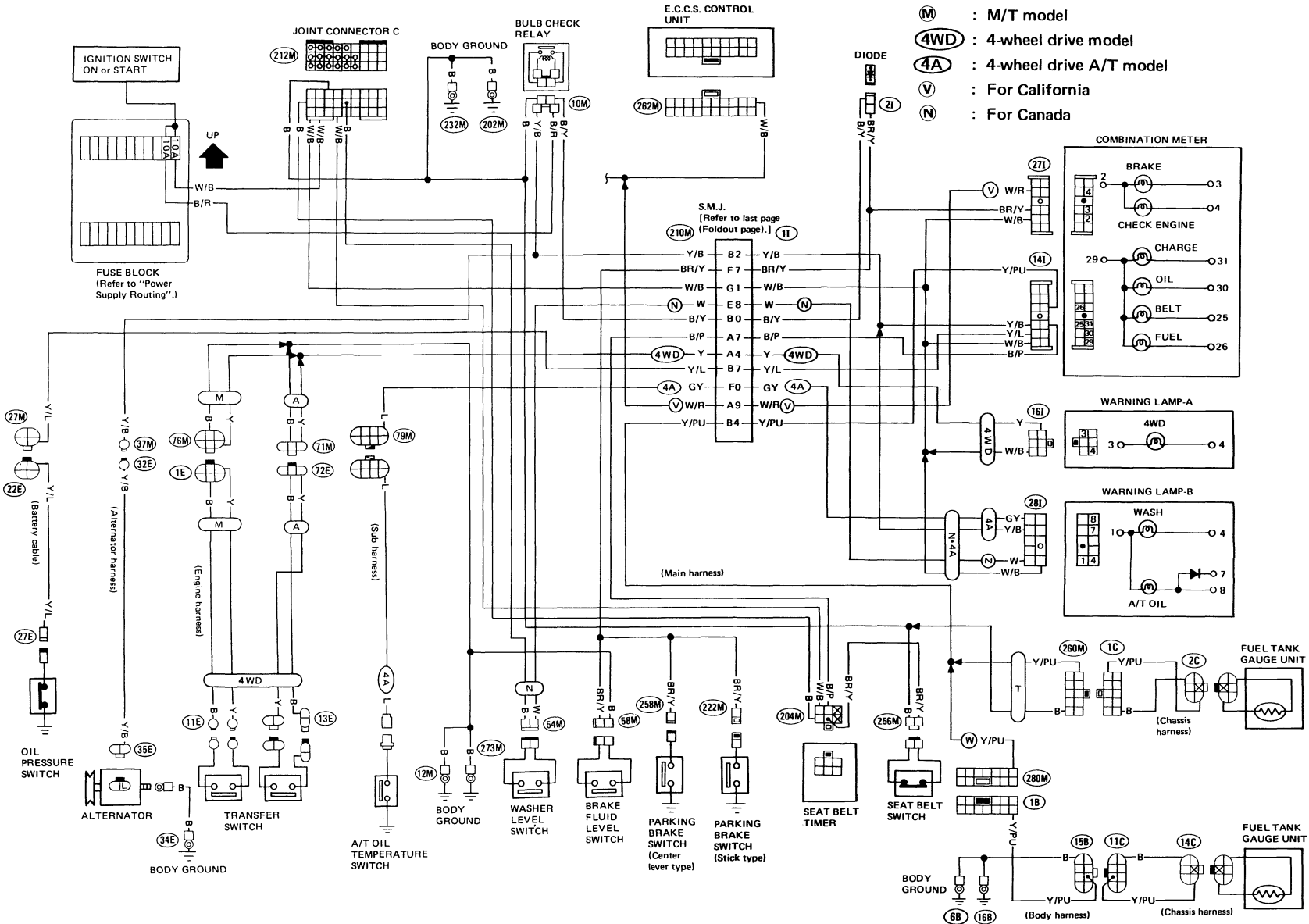

EL-64

SEL673L

WARNING LAMPS AND CHIME

Warning Lamps/Wiring Diagram (Cont'd)

E AND XE MODEL WITH VG ENGINE

- (A) : A/T model
- (V) : For California
- (M) : M/T model
- (N) : For Canada
- (4WD) : 4-wheel drive model
- (4A) : 4-wheel drive A/T model
- (T) : Truck
- (W) : Van and Wagon

EL-65

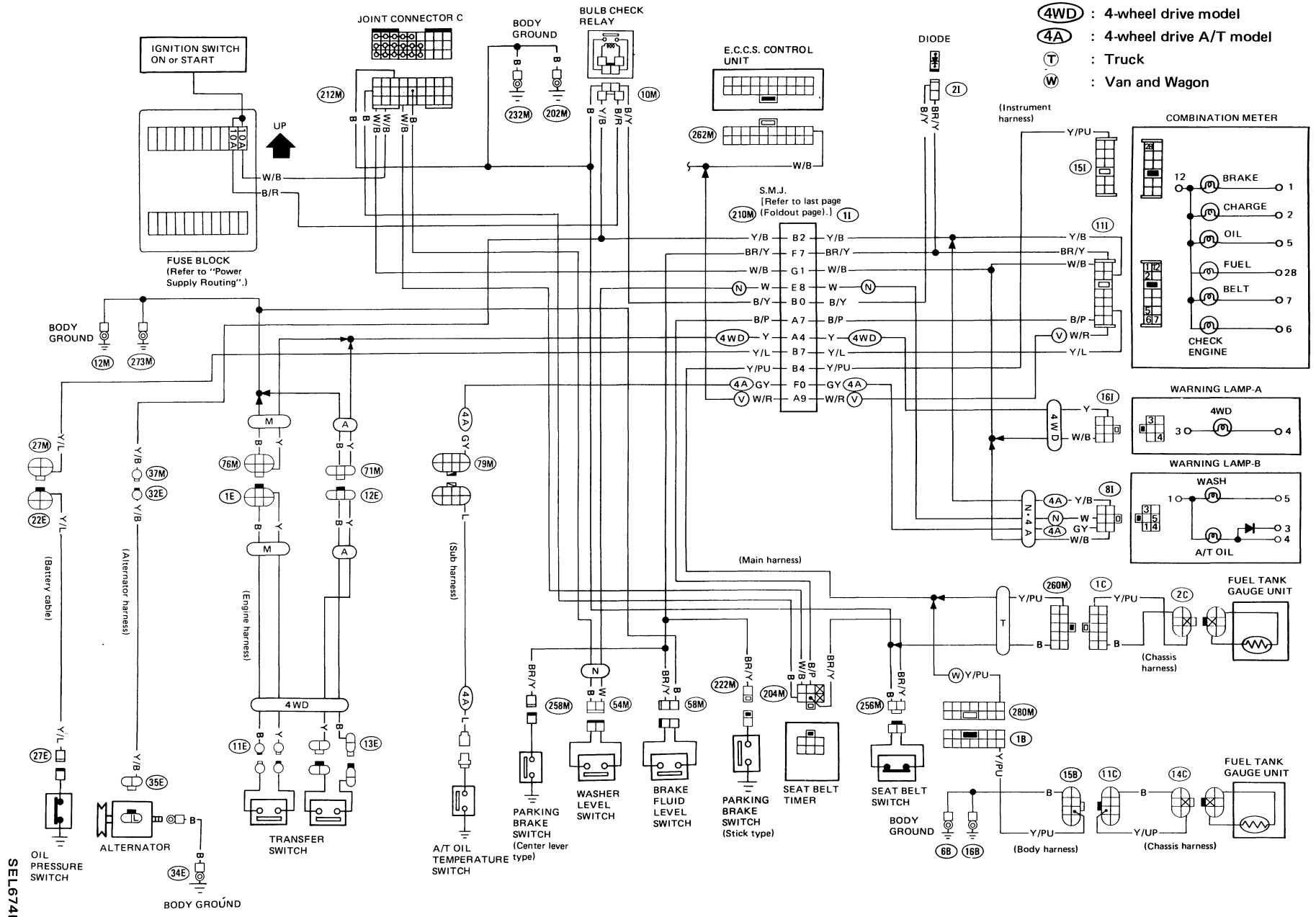

SEL674L

WARNING LAMPS AND CHIME

Warning Lamps/Wiring Diagram (Cont'd)

STD, E AND XE MODEL WITH Z ENGINE

- (A) : A/T model
- (M) : M/T model
- (T) : Truck
- (W) : Van and Wagon
- (4WD) : 4-wheel drive model
- (V) : For California
- (N) : For Canada
- (XE) : E and XE models
- (STD) : STD model

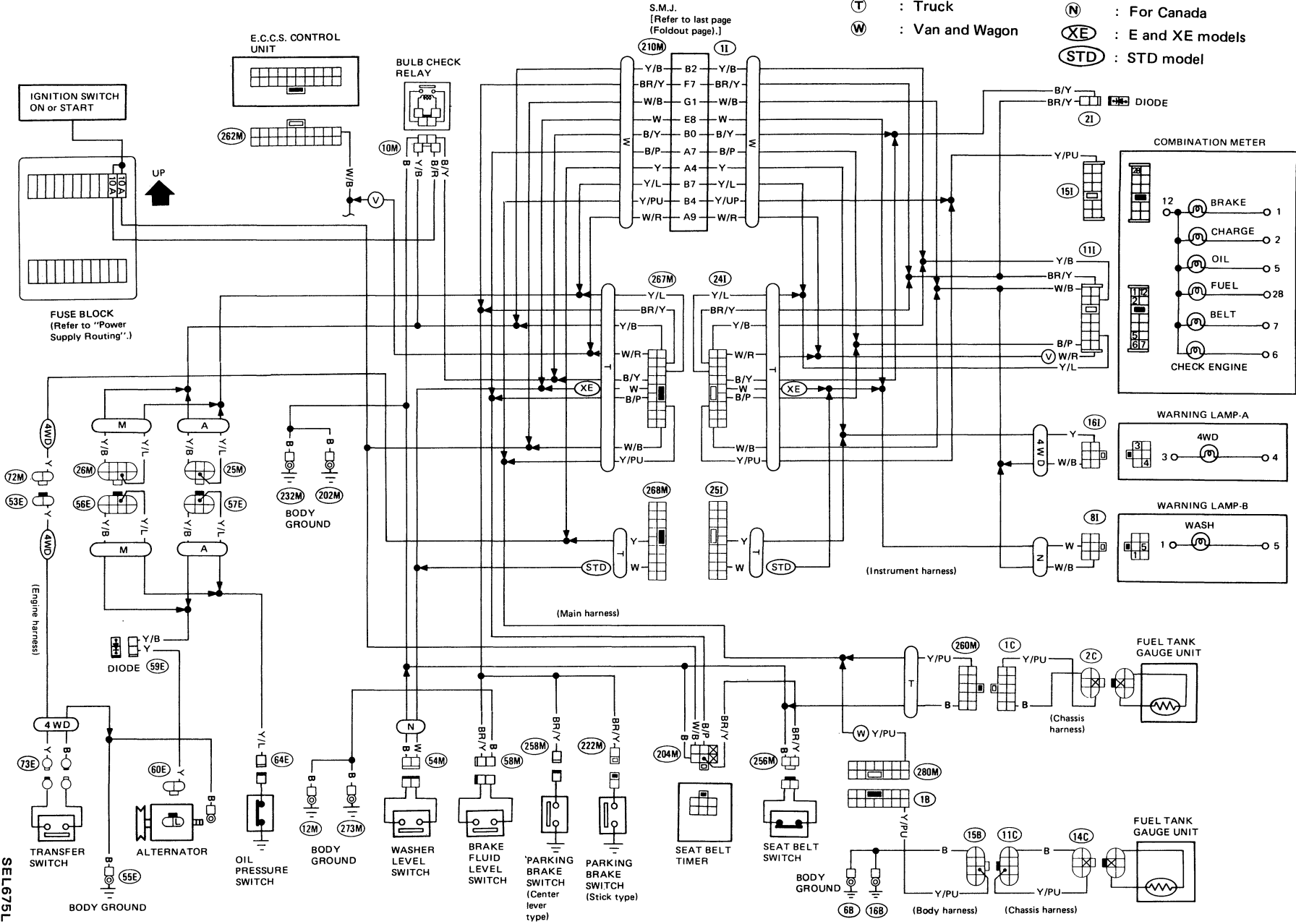

EL-66

SEL675L

WARNING LAMPS AND CHIME

Warning Chime/Wiring Diagram

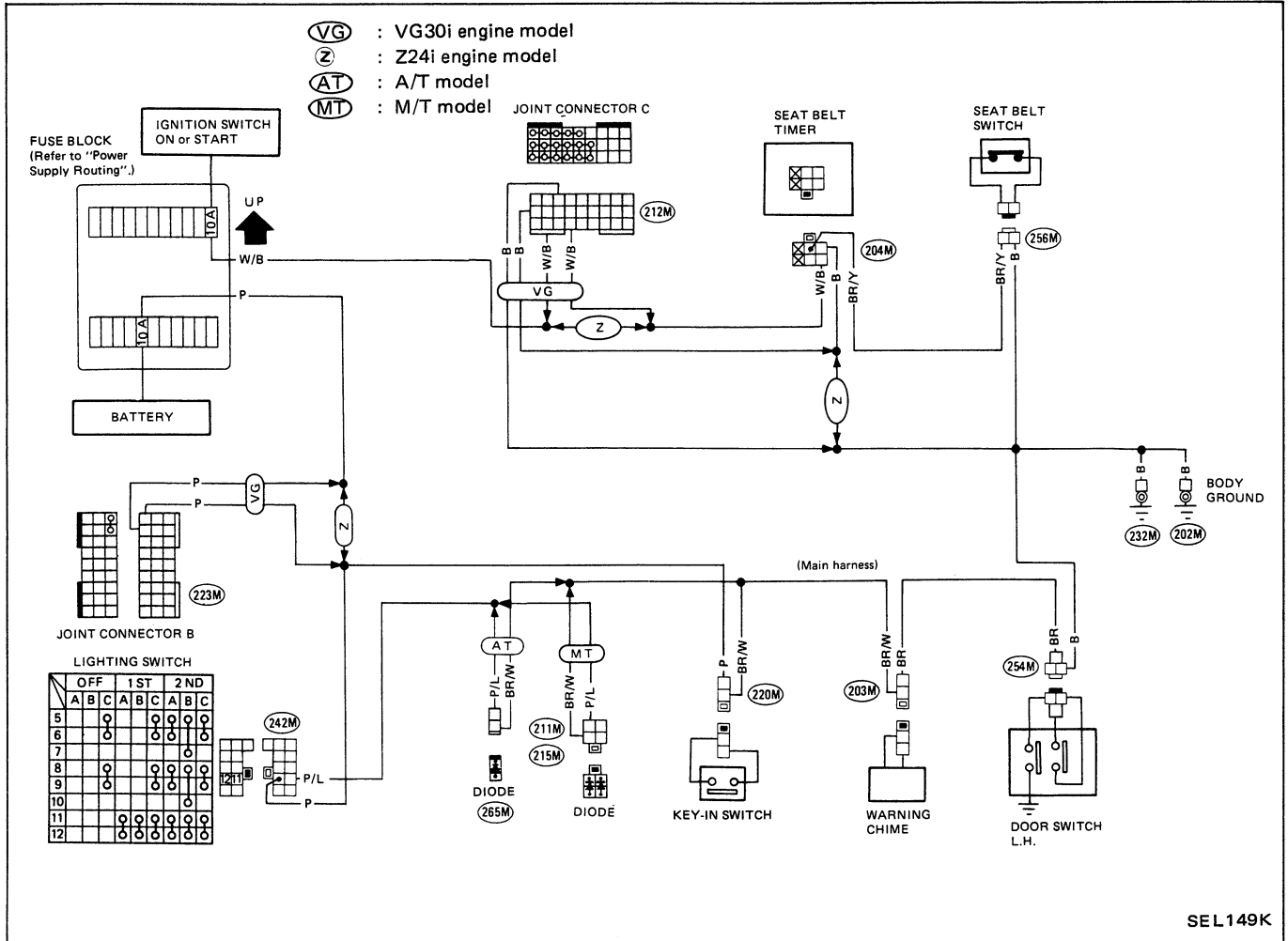

SEL149K

WARNING LAMPS AND CHIME

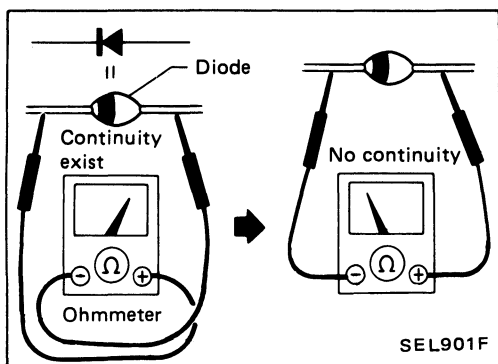

Diode Check

- Check continuity using an ohmmeter.
- Diode is functioning properly if test results are as shown in the figure on the left.

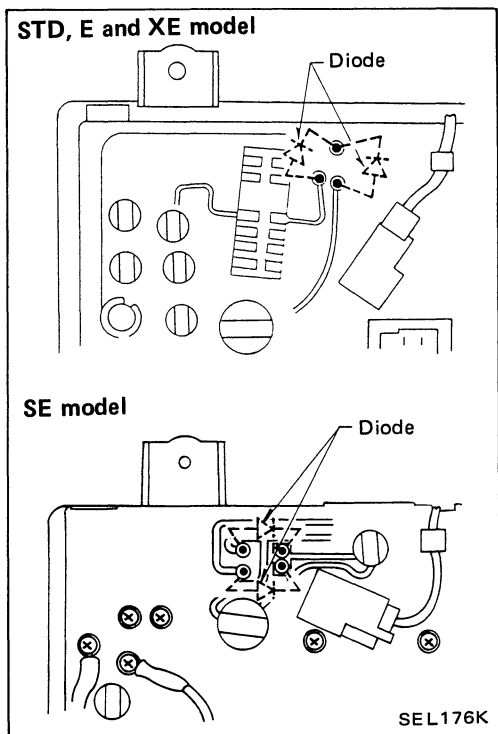

- Diodes for clock illumination lamp are built into the combination meter printed circuit.

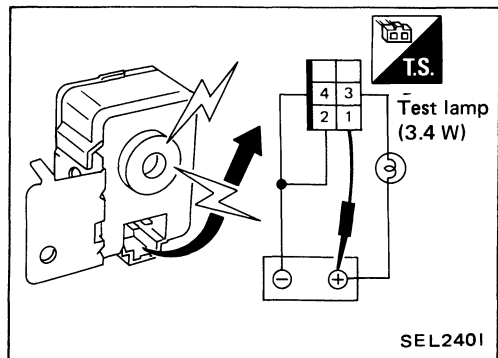

Seat Belt Timer Check

Connect as shown in the figure to the left.

If chime and test lamp come on for 4-8 seconds when connecting terminal ① to battery ⊕ terminal, seat belt timer is normal.

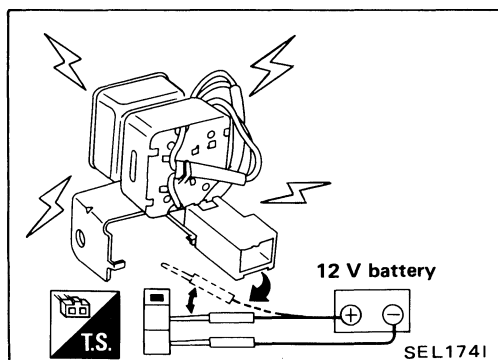

Warning Chime Check

WIPER AND WASHER

WITHOUT INTERMITTENT WIPER

Front Wiper and Washer/Wiring Diagram

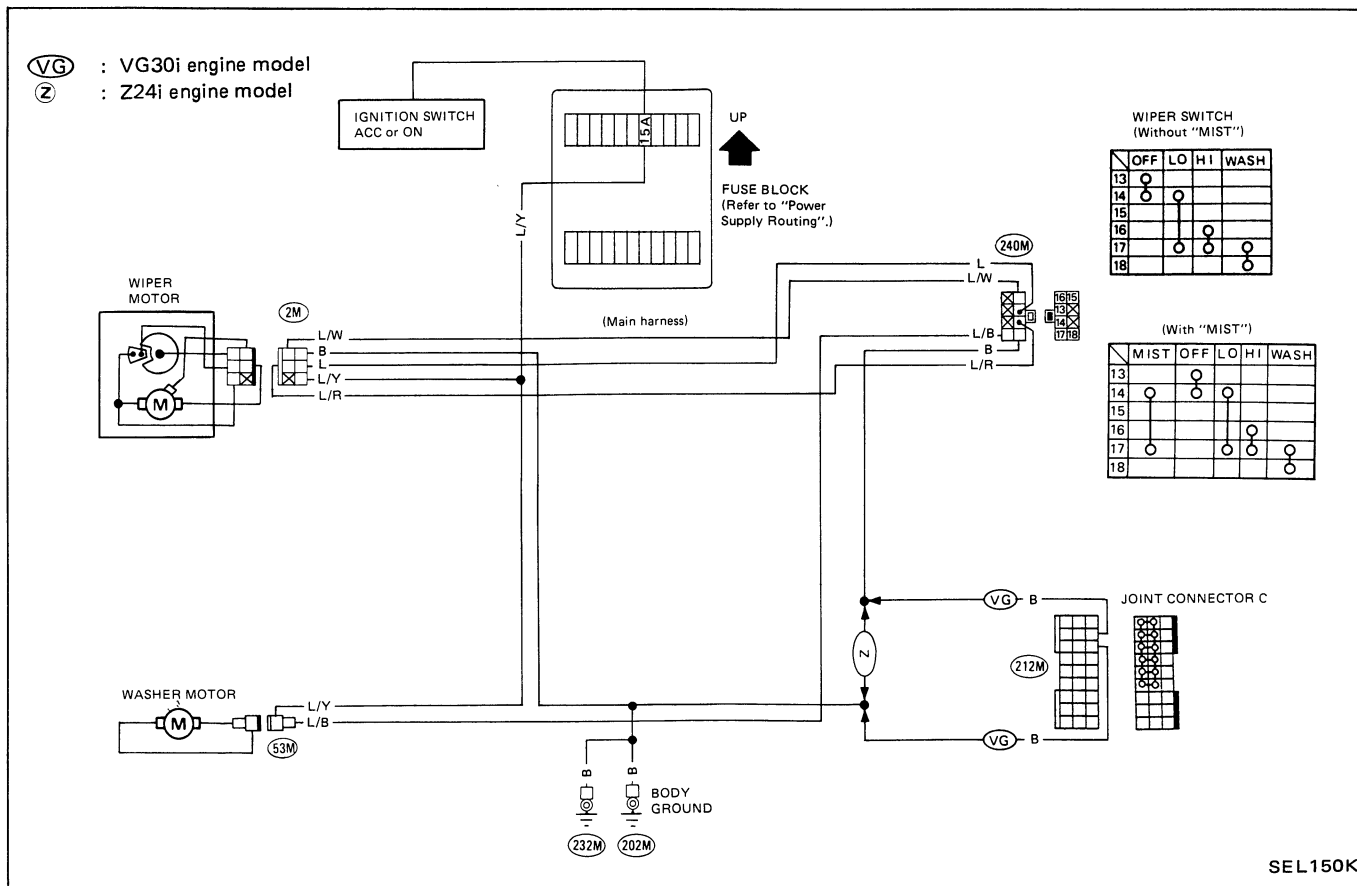

WITH INTERMITTENT WIPER

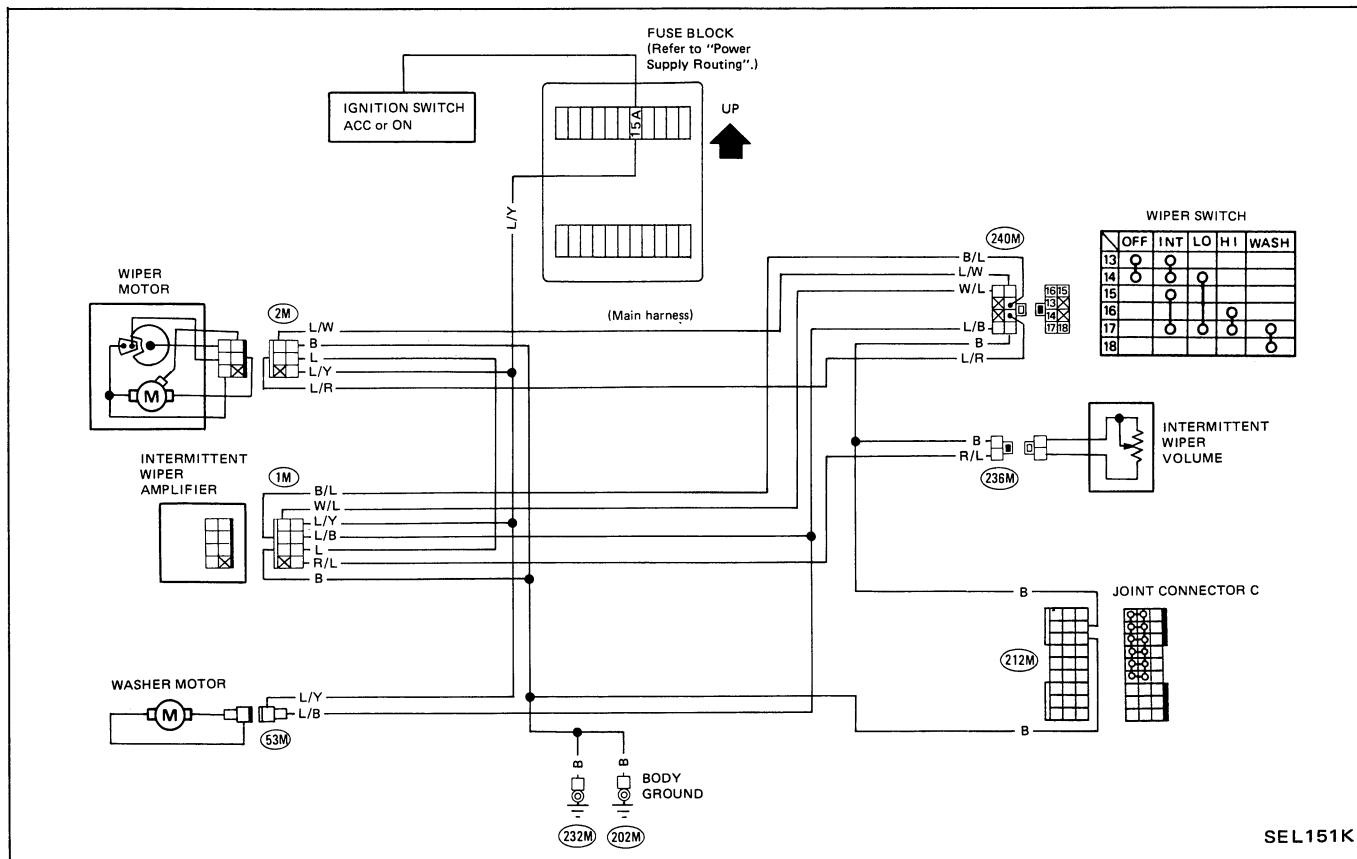

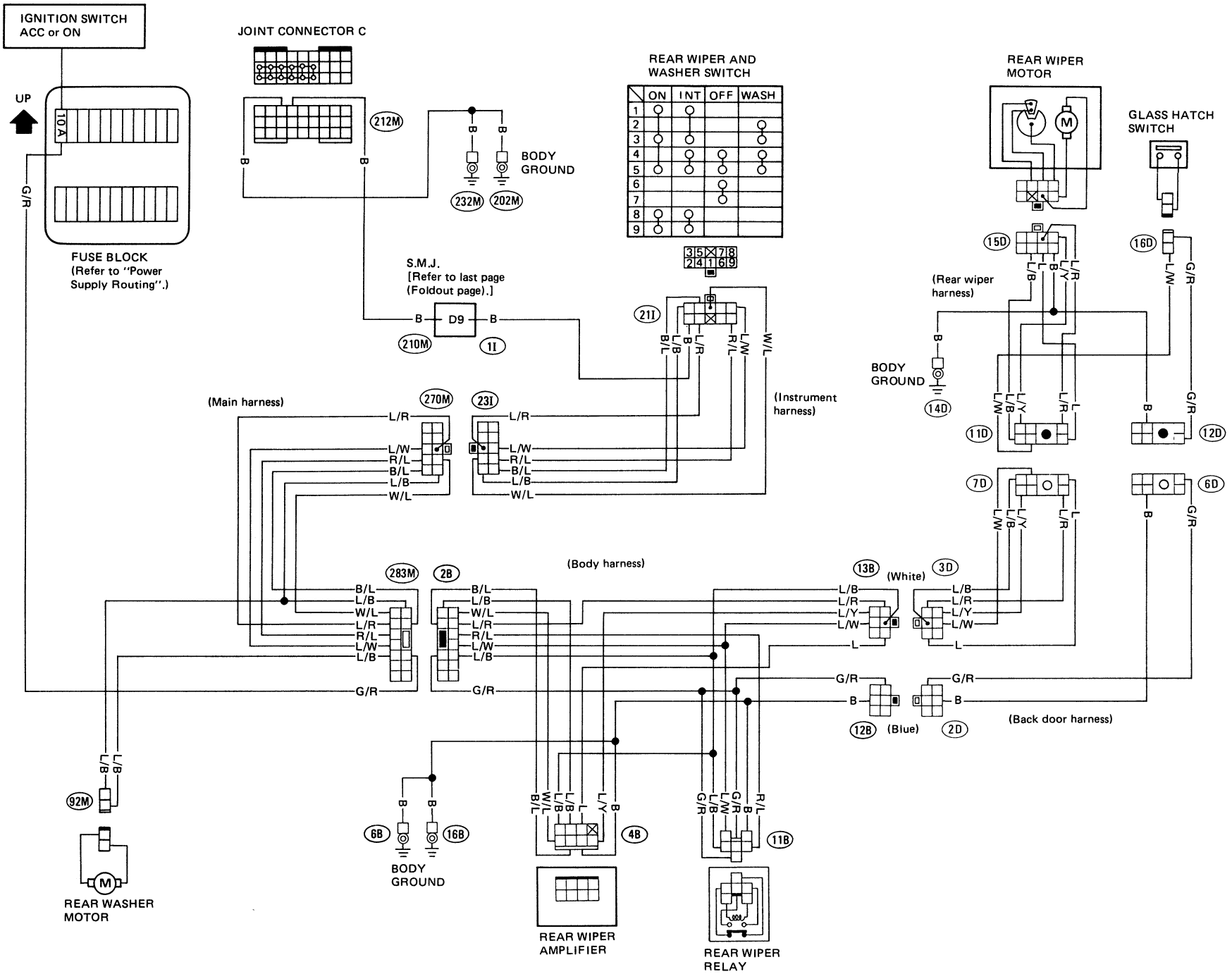

Rear Wiper and Washer/Wiring Diagram

Windshield Wiper Installation

Adjustment

1. Prior to wiper arm installation, turn on wiper switch to operate wiper motor and then turn it "OFF" (Auto Stop).
2. Lift the blade up and then set it down onto glass surface to set the blade center to clearance "C" immediately before tightening nut.
3. Eject washer fluid. Turn on wiper switch to operate wiper motor and then turn it "OFF".
4. Ensure that wiper blades stop within clearance "C".

Clearance "C": 20 - 30 mm (0.79 - 1.18 in)

Installation

- Tighten windshield wiper arm nuts to specified torque.

 13 - 18 N·m (1.3 - 1.8 kg-m, 9 - 13 ft-lb)

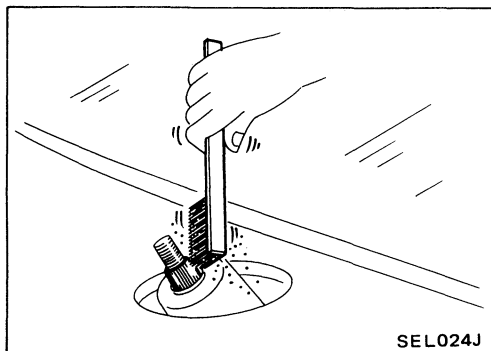
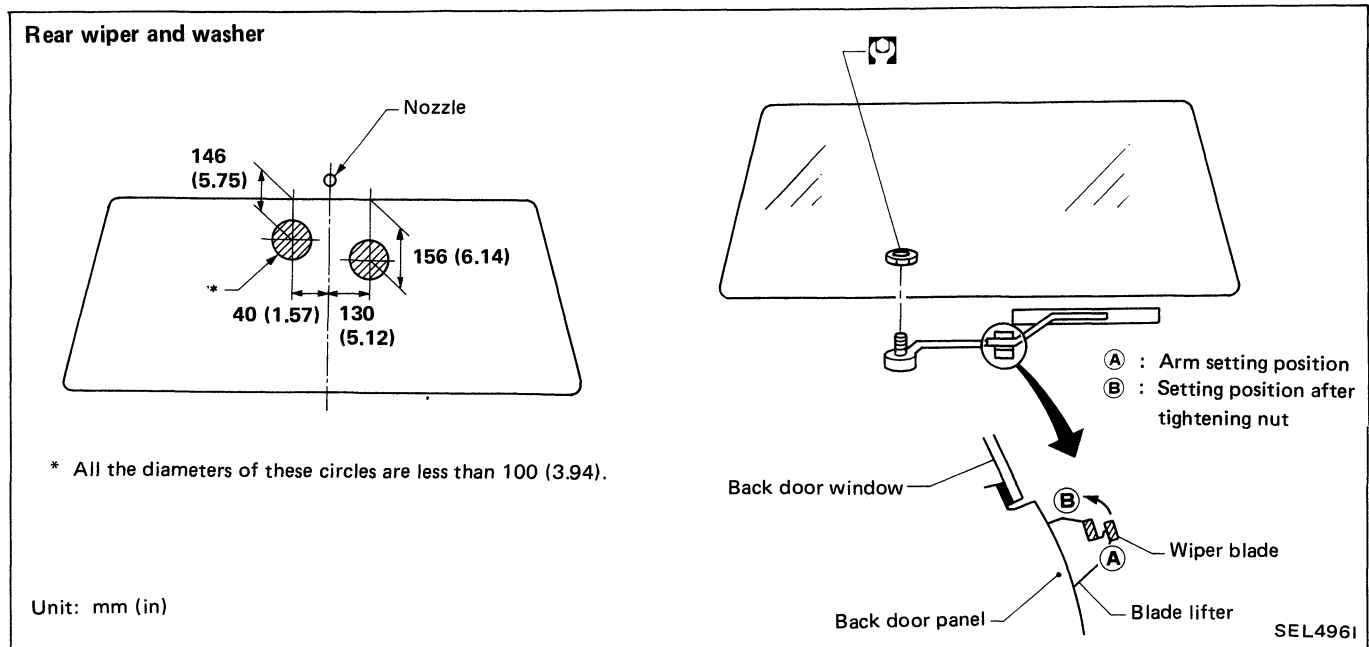
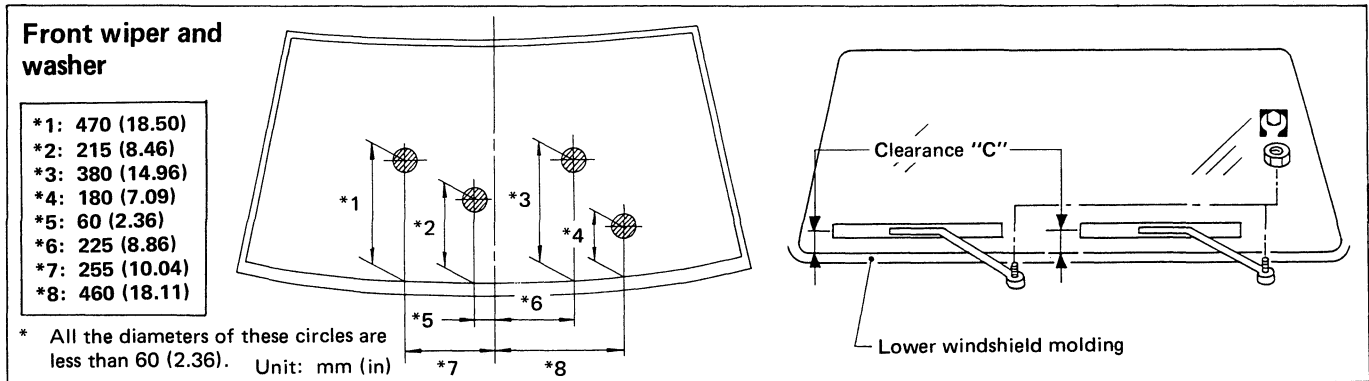

- Before reinstalling wiper arm, clean up the pivot area as illustrated. This will reduce possibility of wiper arm looseness.

WIPER AND WASHER

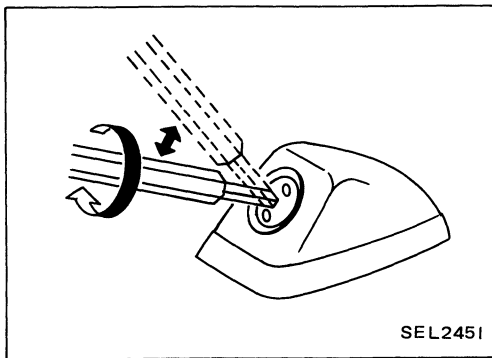

Washer Nozzle Adjustment

- Using Tool J36126, adjust windshield washer nozzle to correct its spray pattern.

Before attempting to turn the nozzle, gently tap the end of the tool to free the nozzle.

This will prevent "rounding out" the small female square in the center of the nozzle.

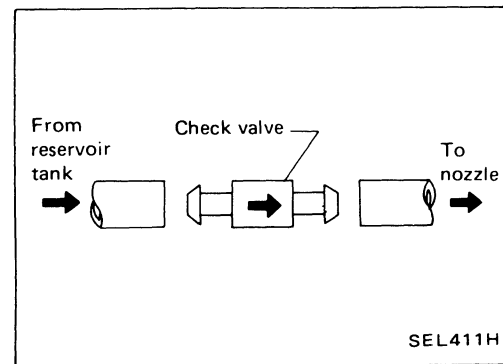
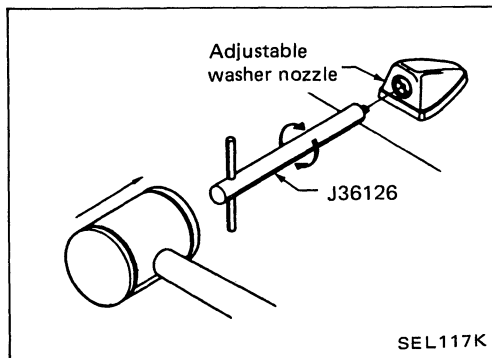

Check Valve

- A check valve is provided in the washer fluid line. Be careful not to connect check valve to washer tube in the wrong direction.

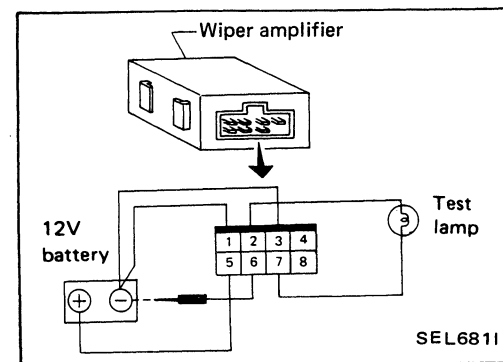

Wiper Amplifier Check

1. Connect as shown in the figure to the left.
2. If test lamp comes on when connected to terminal ⑥ and battery ground, wiper relay is normal.

Wiring Diagram

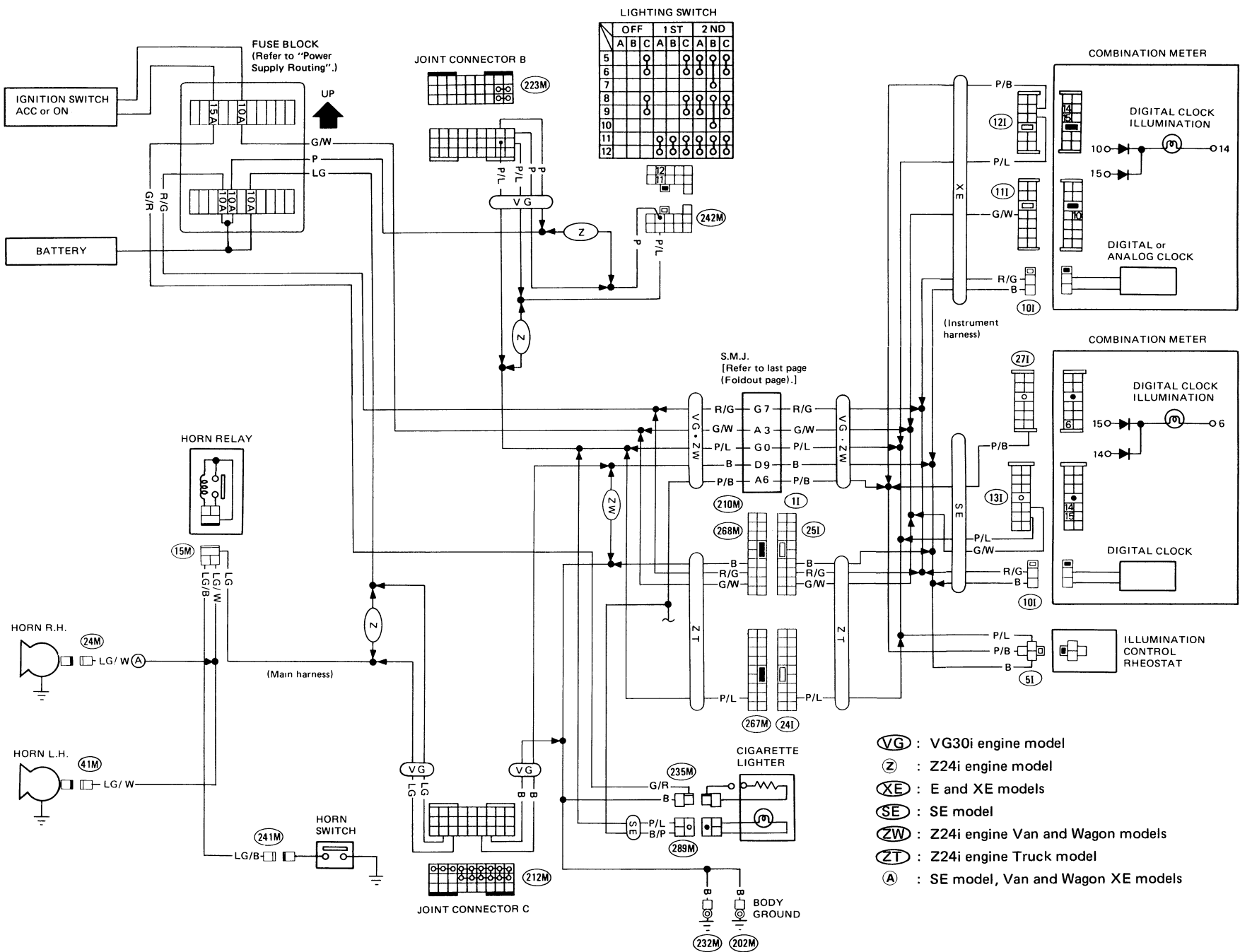

EL-73

SEL676L

REAR WINDOW DEFOGGER

VAN AND WAGON MODEL

Wiring Diagram (Cont'd)

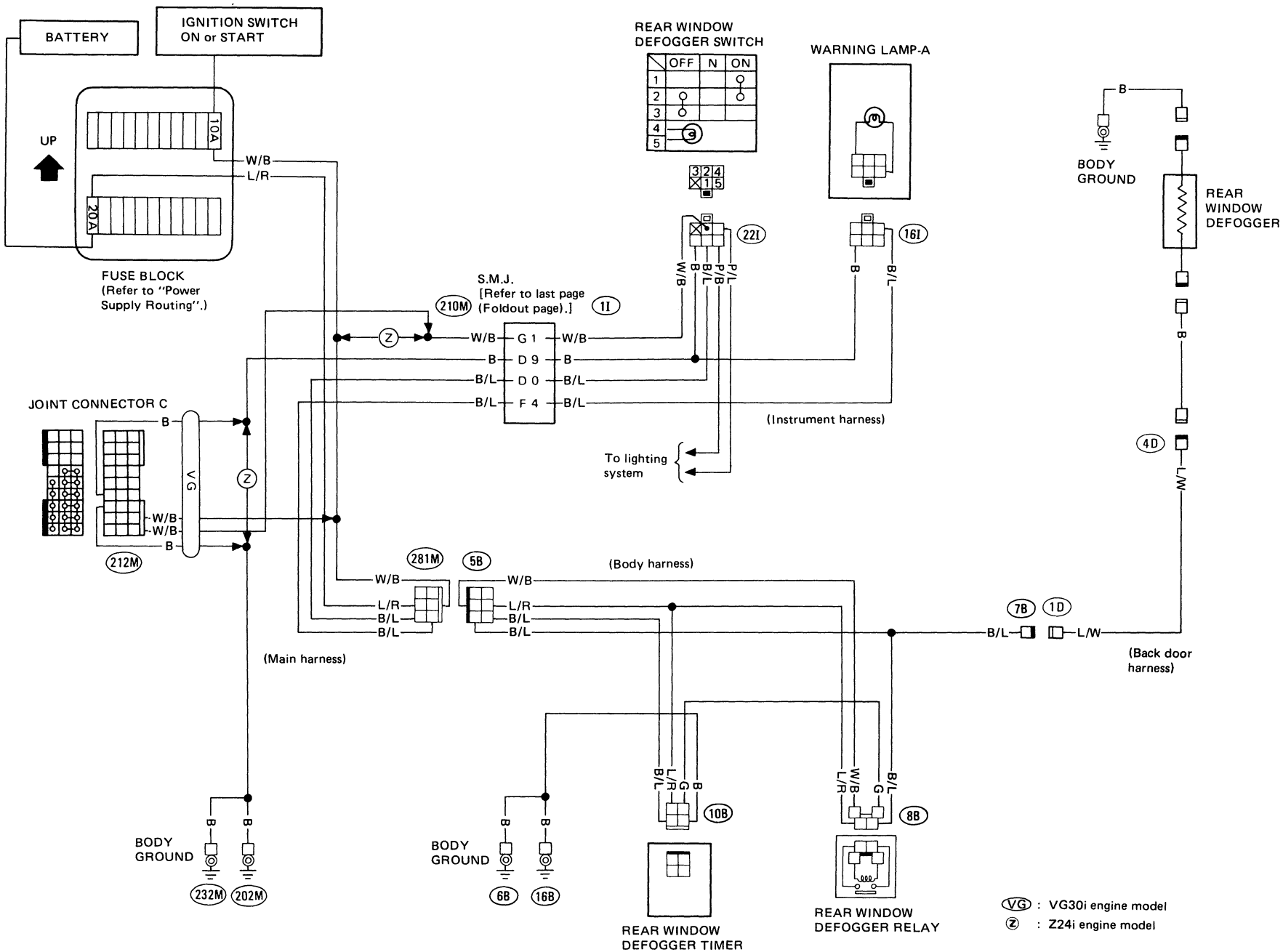

EL-75

SEL154K

REAR WINDOW DEFOGGER

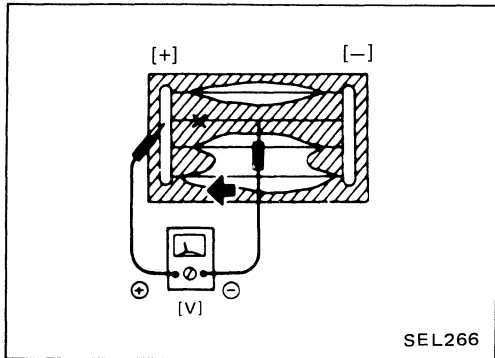
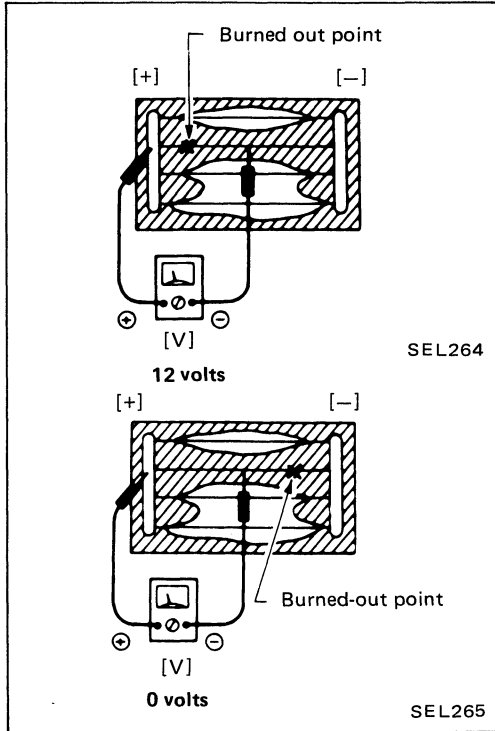
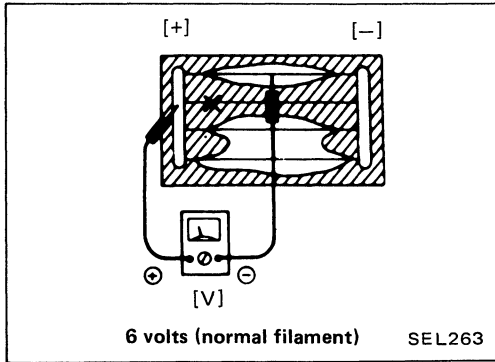

Filament Check

1. Attach probe circuit tester (in volt range) to middle portion of each filament.
2. If a filament is burned out, circuit tester registers 0 or 12 volts.
3. To locate burned out point, move probe to left and right along filament to determine point where tester needle swings abruptly.

REAR WINDOW DEFOGGER

Filament Repair

REPAIR EQUIPMENT

1. Conductive silver composition (Dupont No. 4817 or equivalent)
2. Ruler 30 cm (11.8 in) long
3. Drawing pen
4. Heat gun
5. Alcohol
6. Cloth

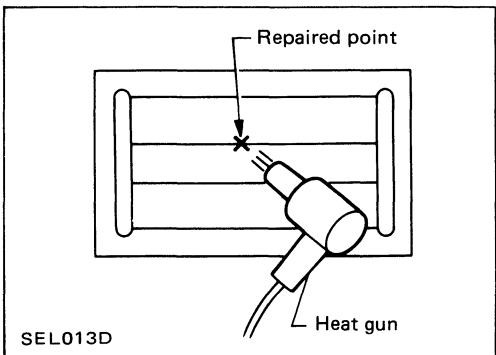
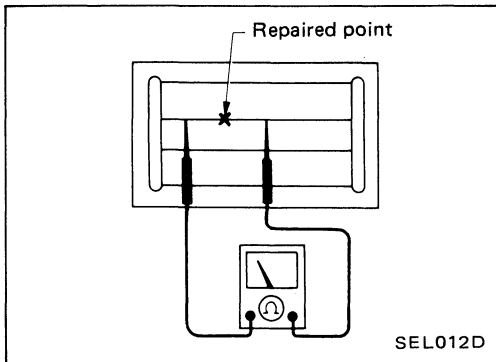
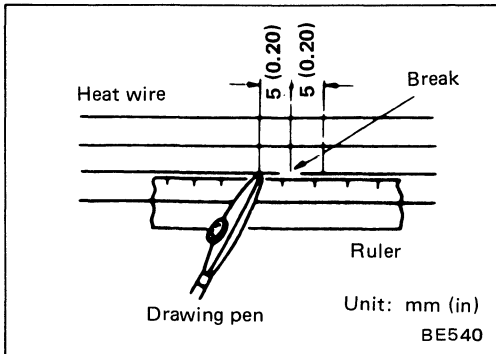

REPAIRING PROCEDURE

1. Wipe broken heat wire and its surrounding area clean with a cloth dampened in alcohol.
2. Apply a small amount of conductive silver composition to tip of drawing pen.

Shake silver composition container before use.

3. Place ruler on glass along broken line. Deposit conductive silver composition on break with drawing pen. Slightly overlap existing heat wire on both sides [preferably 5 mm (0.20 in)] of the break.
4. After repair has been completed, check repaired wire for continuity. This check should be conducted 10 minutes after silver composition is deposited.

Do not touch repaired area while test is being conducted.

5. Apply a constant stream of hot air directly to the repaired area for approximately 20 minutes with a heat gun. A minimum distance of 3 cm (1.2 in) should be kept between repaired area and hot air outlet. If a heat gun is not available, let the repaired area dry for 24 hours.

AUDIO

Audio/Wiring Diagram

1- OR 2-SPEAKER TYPE

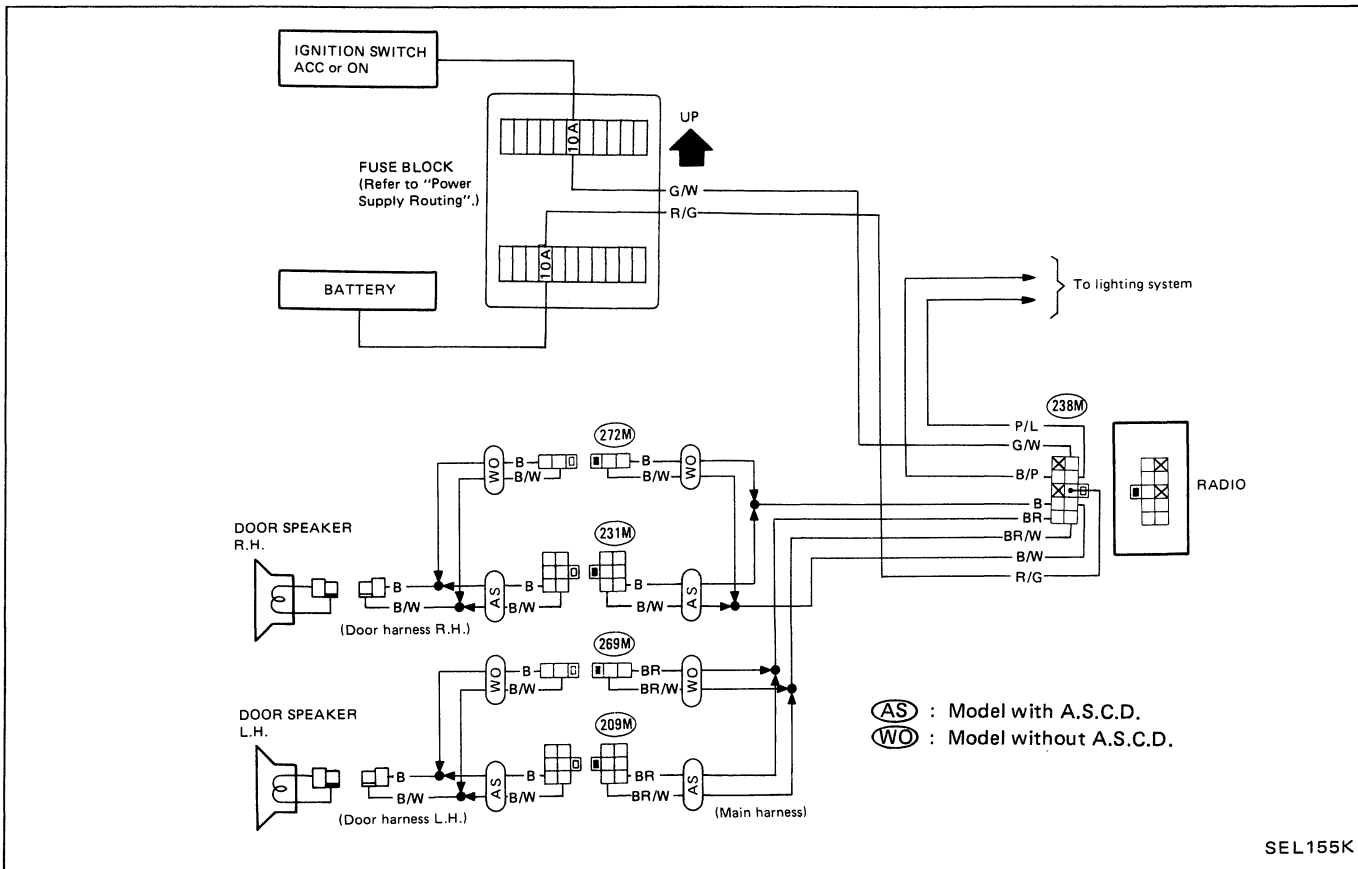

4-SPEAKER TYPE

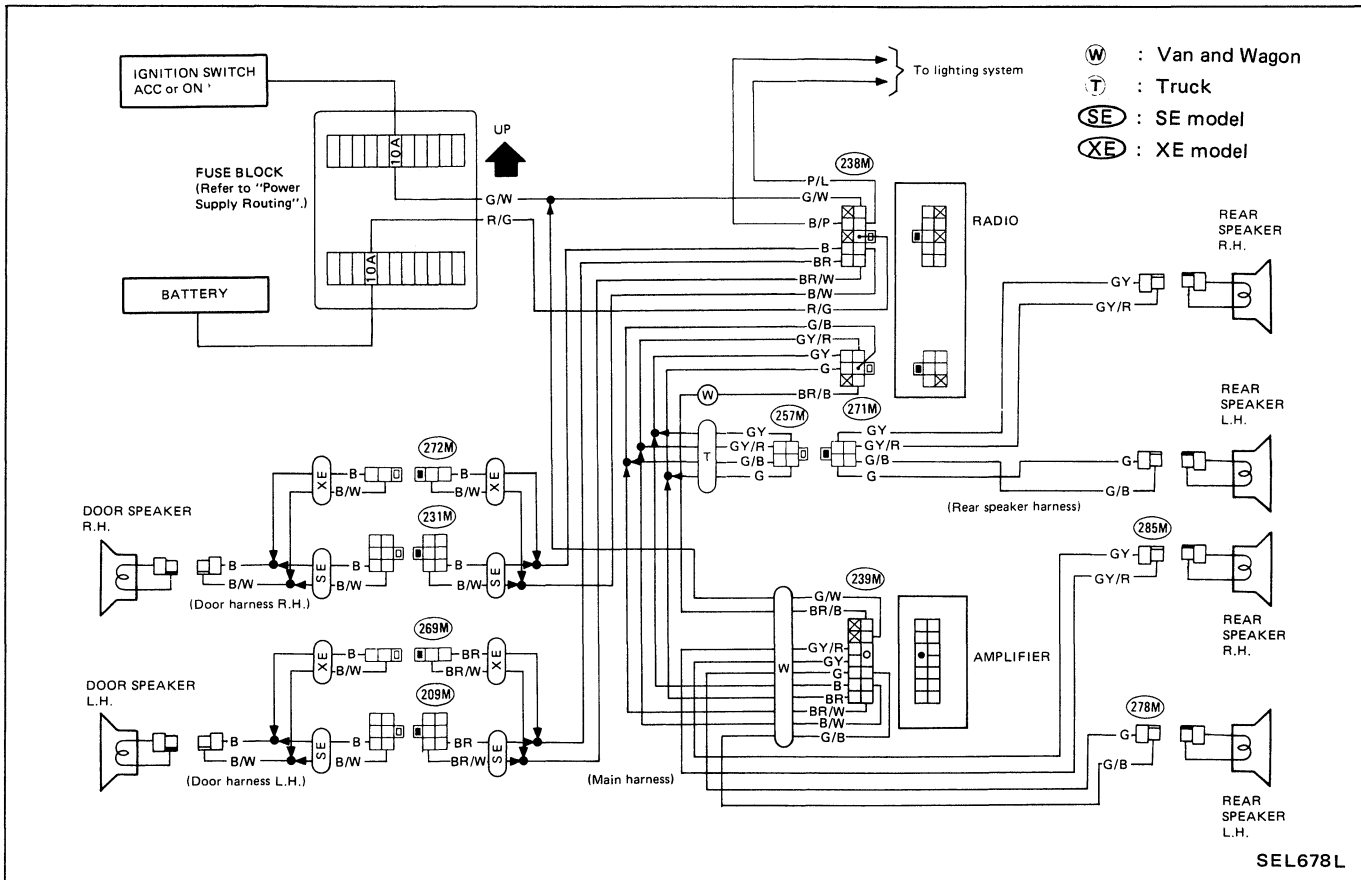

AUDIO

Location of Antenna

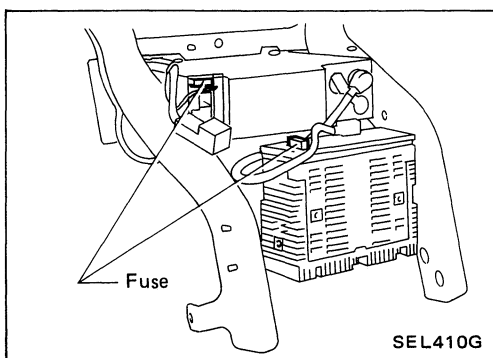
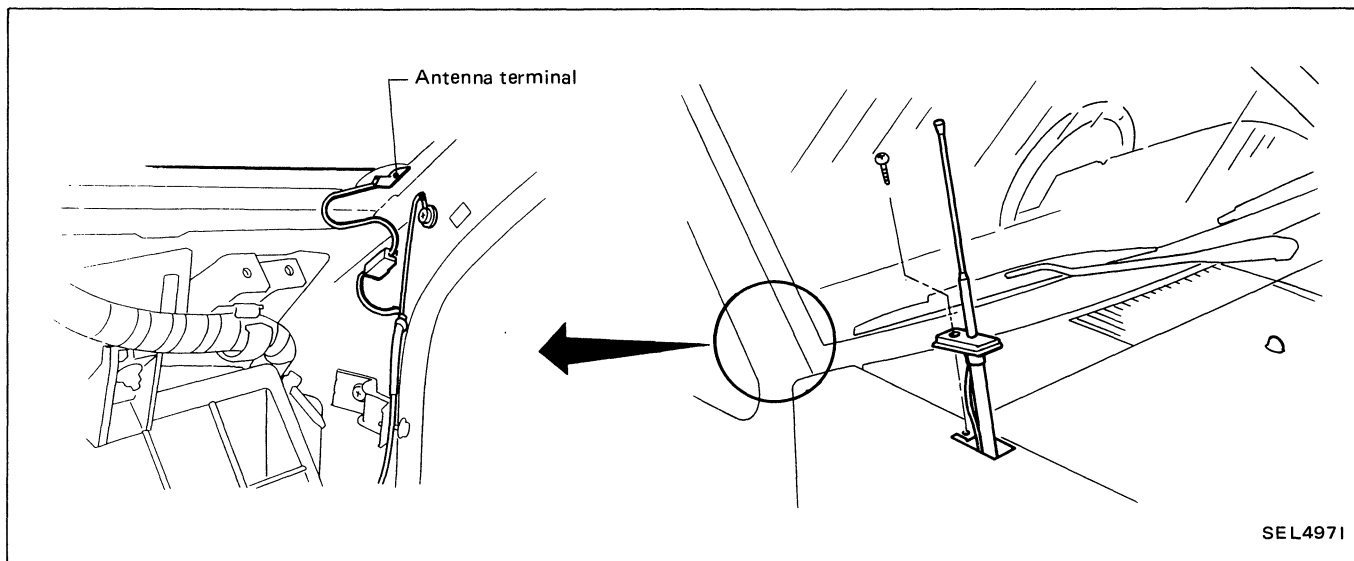

Radio Fuse Check

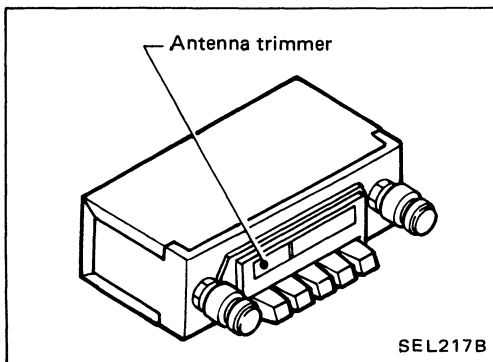

Antenna Trimmer Adjustment

The antenna trimmer should be adjusted in the following cases:

- Fading and weak MW (AM) reception.
- After installation of new antenna, feeder cable or radio receiver.

Before adjusting, be sure to check harness and antenna feeder cable connectors for proper connection.

1. Extend antenna completely.
2. Turn radio on, and turn volume control to increase speaker volume.
3. Tune in the weakest station (barely audible) on dial at the range around 14 (1,400 kHz).
4. Turn antenna trimmer to left or right slowly, and set it in the position where reception is strongest.

CAUTION:

Do not turn antenna trimmer more than one-half turn.

AUDIO

Element Check

1. Attach probe circuit tester (in ohm range) to antenna terminal on each side.

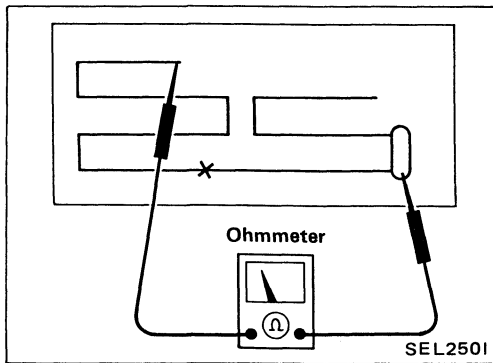

2. If an element is broken, no continuity will exist.

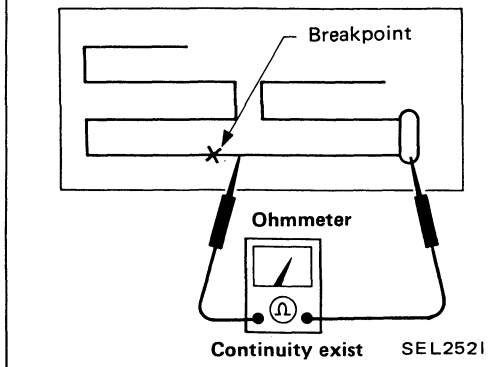
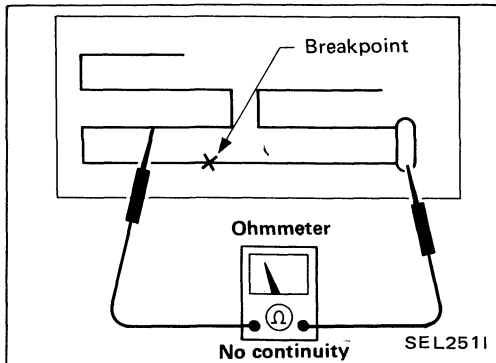

3. To locate broken point, move probe to left and right along element to determine point where tester needle swings abruptly.

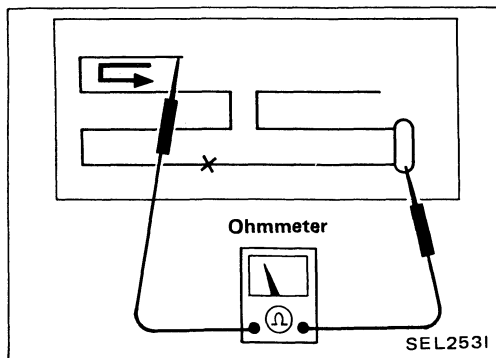

Element Repair

Refer to REAR WINDOW DEFOGGER "Filament Repair".

AUTOMATIC SPEED CONTROL DEVICE (A.S.C.D.)

Schematic

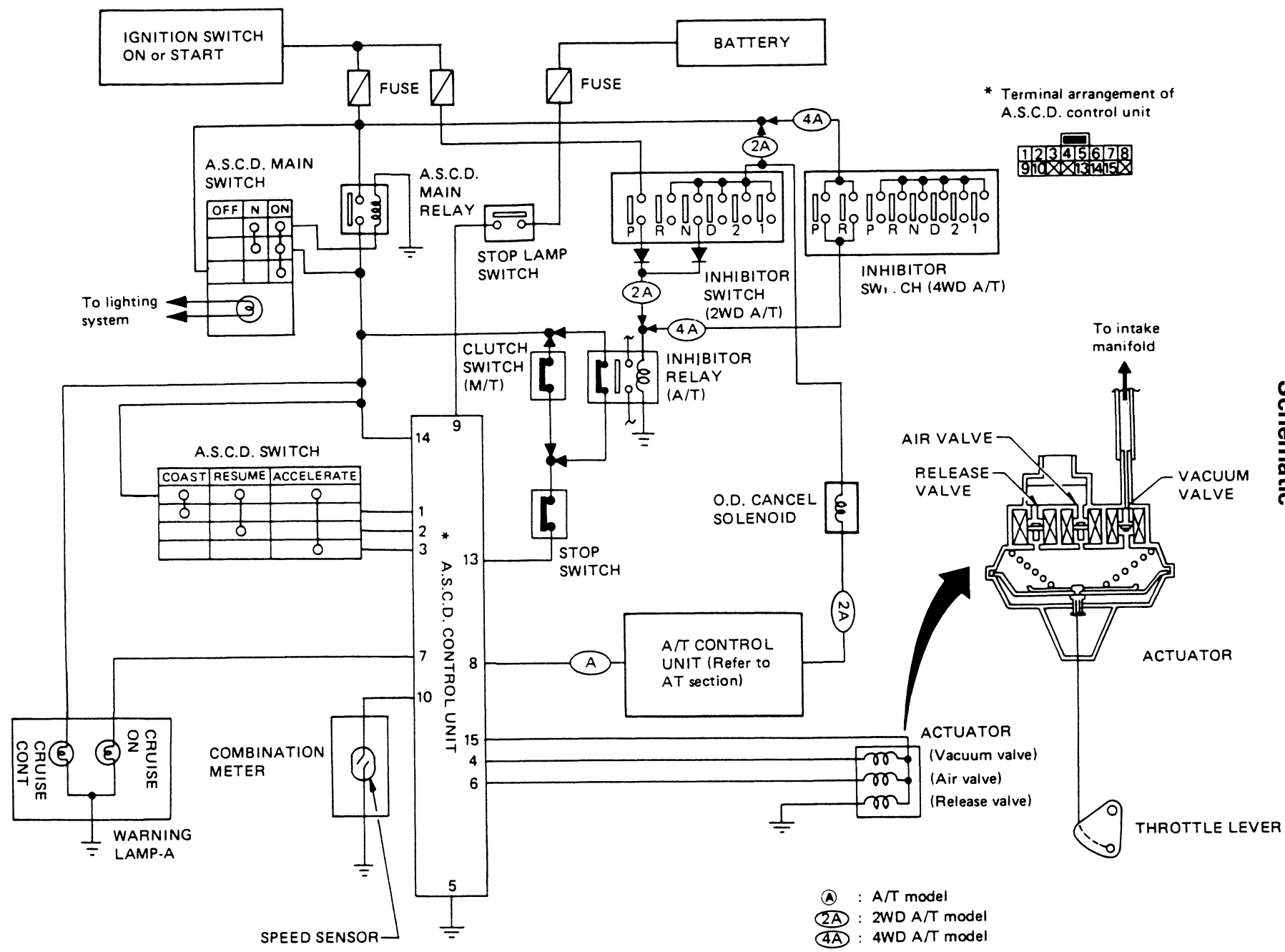

EL-81

SEL679L

AUTOMATIC SPEED CONTROL DEVICE (A.S.C.D.)

Wiring Diagram

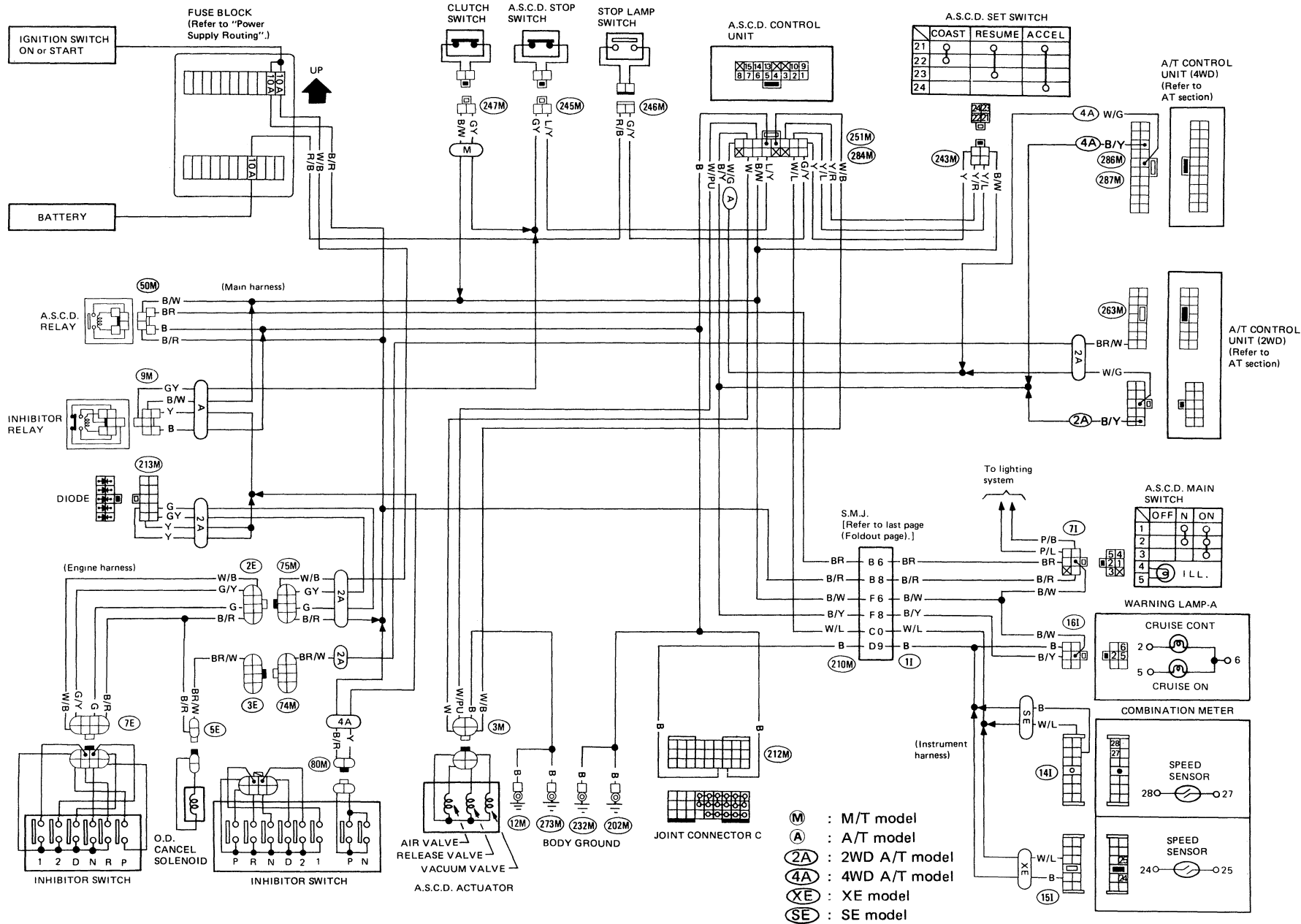

EL-82

SEL991K

AUTOMATIC SPEED CONTROL DEVICE (A.S.C.D.)

Trouble-shooting

Symptom	Refer to TROUBLE-SHOOTING PROCEDURE.
A.S.C.D. control unit cannot be set properly.	1
Resume switch will not operate.	2
Accelerate switch will not operate.	3
Engine hunts.	4
Large difference between set vehicle speed and actual speed.	5
A/T model only <ul style="list-style-type: none"> • When A.S.C.D. is set while vehicle is operating in "O.D." range, O.D. will be cancelled and shifting to O.D. cannot be made thereafter. • O.D. will not be cancelled even if actual vehicle speed is 6 km/h (4 MPH) lower than set speed. (Set speed cannot be maintained.) • O.D. will not be cancelled even if accelerator switch is turned "ON". 	6

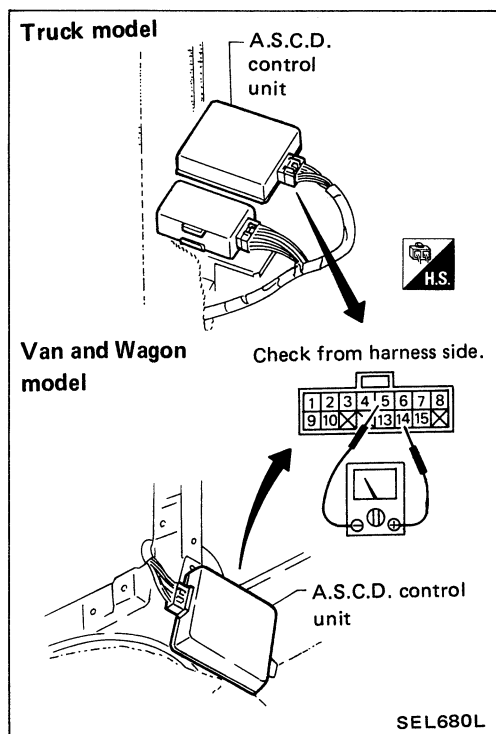

PREPARATION FOR TROUBLE-SHOOTING

1. Remove driver's side dash cover. (Truck model)
Remove L.H. side rear side trim (Van and Wagon model).
2. Remove A.S.C.D. control unit with harness connected.
3. Perform check from harness side using circuit tester, with harness connector connected.

POWER SUPPLY CIRCUIT CHECK

- Measure voltage across ⑭ and ⑮
Approx. 12 [V] O.K.

AUTOMATIC SPEED CONTROL DEVICE (A.S.C.D.)

Trouble-shooting (Cont'd)

1 A.S.C.D. control unit cannot be set properly.

Turn A.S.C.D. main switch "OFF" and then "ON" to make sure indicator illuminates.

Yes

No

Check for loose vacuum hose.

Check A.S.C.D. main switch and A.S.C.D. main relay.

O.K.

Check power supply circuit for A.S.C.D. control unit.

O.K.

N.G.

Check stop switch, clutch switch (M/T model), inhibitor relay and inhibitor switch (A/T model).

O.K.

Check harness between A.S.C.D. power supply circuit.

Check A.S.C.D. set switch circuit for A.S.C.D. control unit.

O.K.

N.G.

Check A.S.C.D. set switch, and harness between control unit and set switch.

Go to "A.S.C.D. Actuator Check".

O.K.

N.G.

* (Next page)

Replace actuator.

POWER SUPPLY CIRCUIT CHECK

1. Release brake and clutch pedals.
2. Turn ignition switch to "ON".
3. Connect voltmeter from harness side.
4. Turn A.S.C.D. main switch to "ON".
5. Check voltage between ⑬ and ⑤.

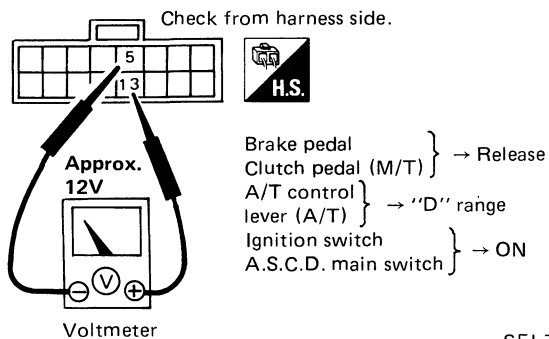

SET SWITCH CIRCUIT CHECK

1. Turn ignition switch to "OFF".
2. Connect ohmmeter from harness side.
3. Push A.S.C.D. set switch.
4. Check continuity between ① and ⑭.

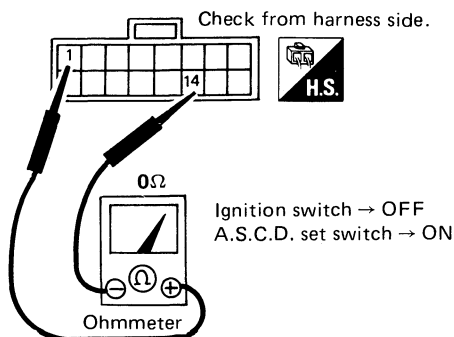

Trouble-shooting (Cont'd)

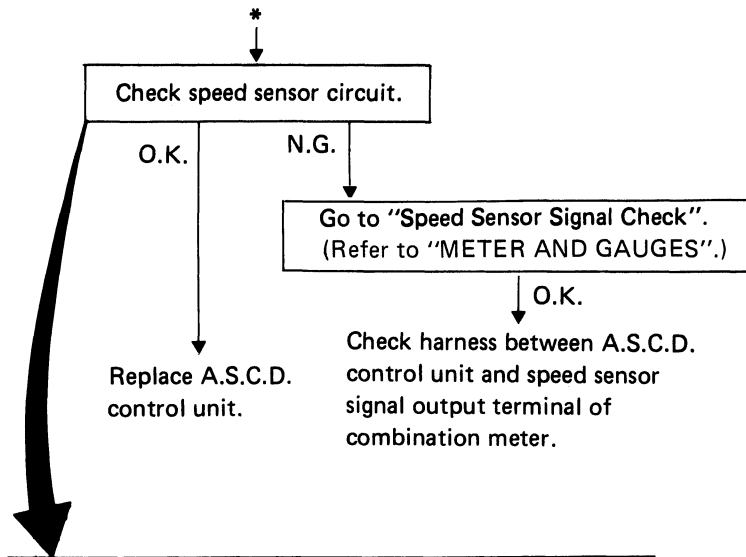

SPEED SENSOR CIRCUIT CHECK

1. Turn ignition switch to "OFF".
 2. Disconnect speedometer cable from transmission.
 3. Connect an ohmmeter between ⑩ and ⑤ from harness side.
 4. Turn ignition switch to "ON".
 5. Slowly turn speedometer cable pinion by hand to make sure ohmmeter pointer deflects.
- Ohmmeter pointer deflects twice per rotation of pinion.

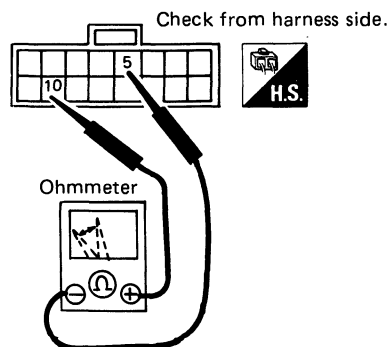

SEL800F

AUTOMATIC SPEED CONTROL DEVICE (A.S.C.D.)

Trouble-shooting (Cont'd)

2 Resume switch will not operate.

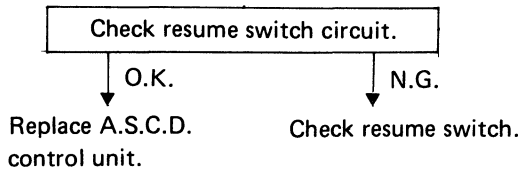

3 Accelerate switch will not operate.

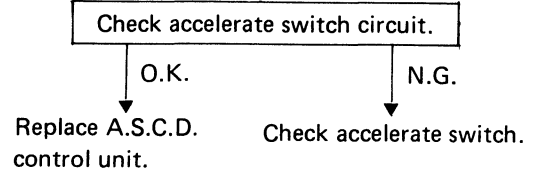

RESUME SWITCH CIRCUIT CHECK

1. Turn ignition switch to "OFF".
2. Connect ohmmeter from harness side.
3. Turn resume switch to "ON".
4. Check continuity between ② and ⑭

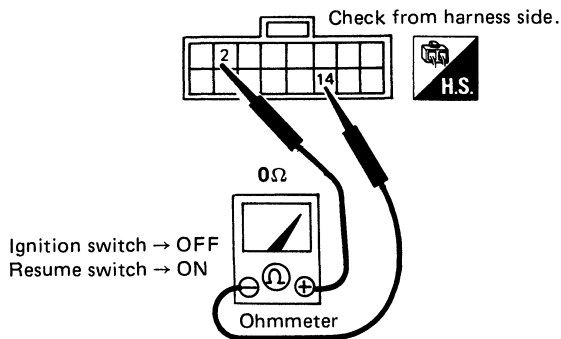

SEL801F

ACCELERATE SWITCH CIRCUIT CHECK

1. Turn ignition switch to "OFF".
2. Connect ohmmeter from harness side.
3. Turn accelerate switch to "ON".
4. Check continuity between ③ and ⑭

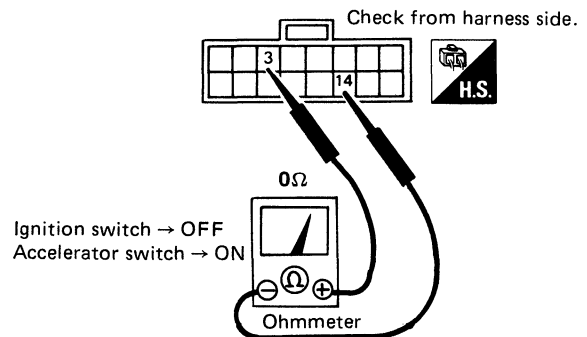

SEL802F

4 Engine hunts.

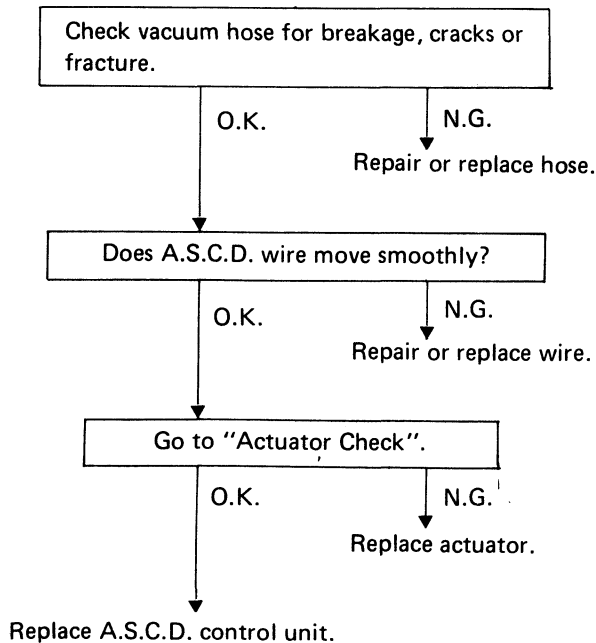

5 Large difference between set vehicle speed and actual speed.

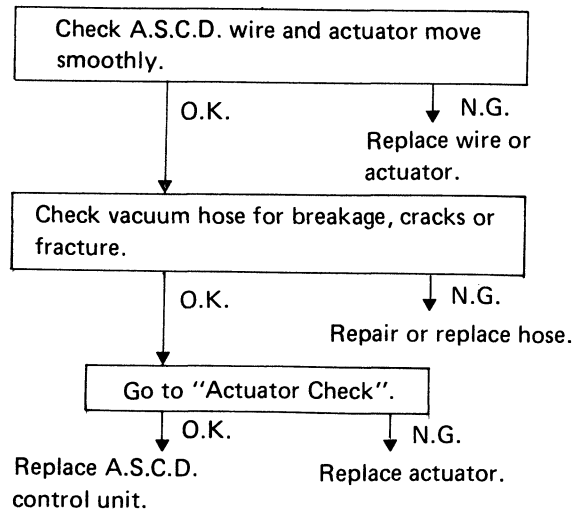

AUTOMATIC SPEED CONTROL DEVICE (A.S.C.D.)

A.S.C.D. Wire Adjustment

CAUTION:

- Be careful not to twist A.S.C.D. wire when removing it.
- Do not tense A.S.C.D. wire excessively during adjustment.

After confirming that accelerator wire is properly adjusted, adjust the tension of A.S.C.D. wire in the following manner:

- (1) After adjusting the length of the accel wire, turn a securing nut by 1/2 to 1 turn from throttle open starting position to the wire loosening direction to fix. (Must be securing carried out to prevent response delay of operation of the A.S.C.D.)
 - (2) Securely tighten lock nut to hold adjusting nut in place.
- For A.S.C.D. stop switch and clutch switch adjustment, refer to BR and CL sections.

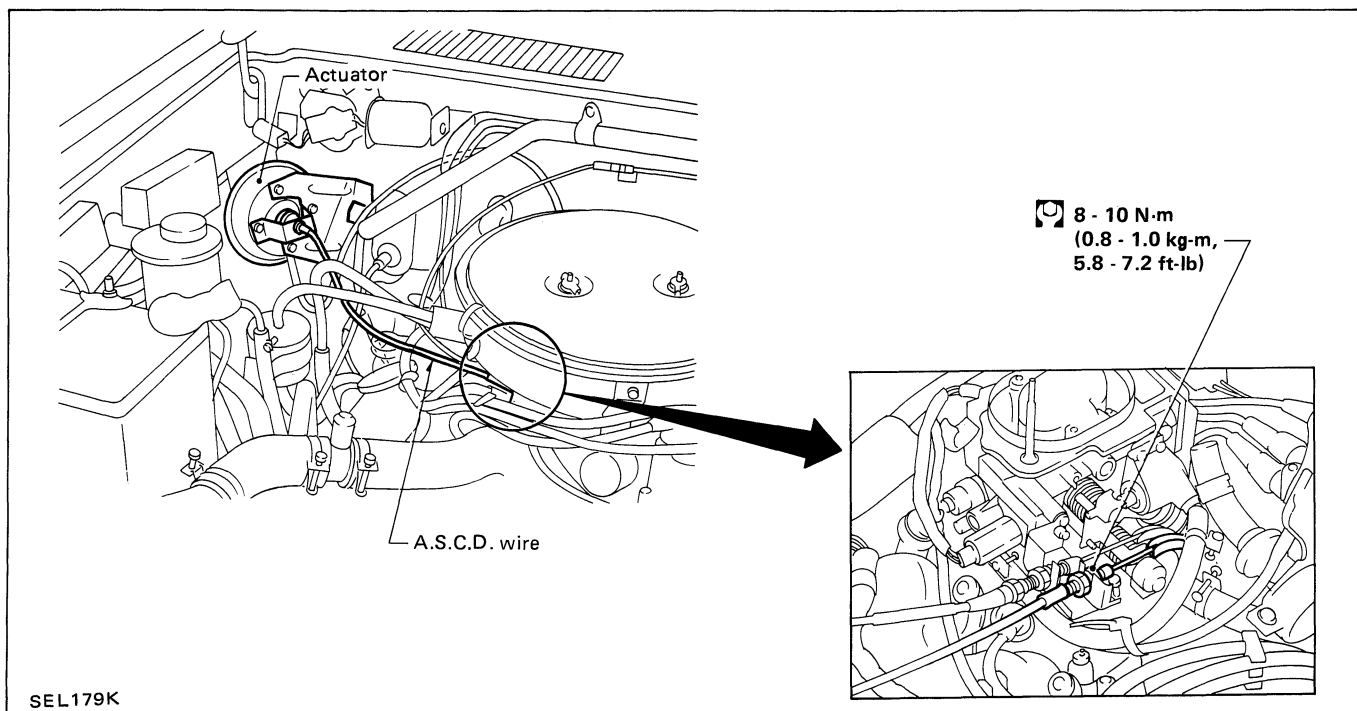

Engine Compartment

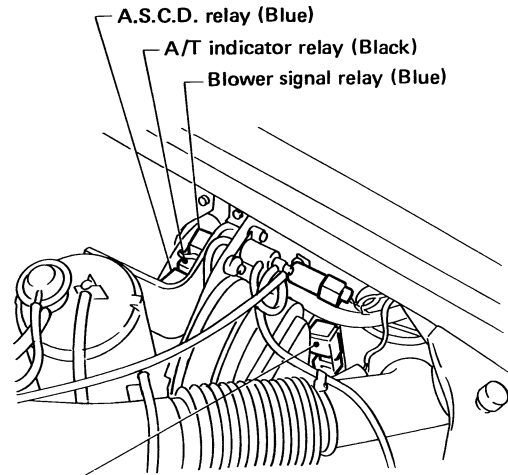
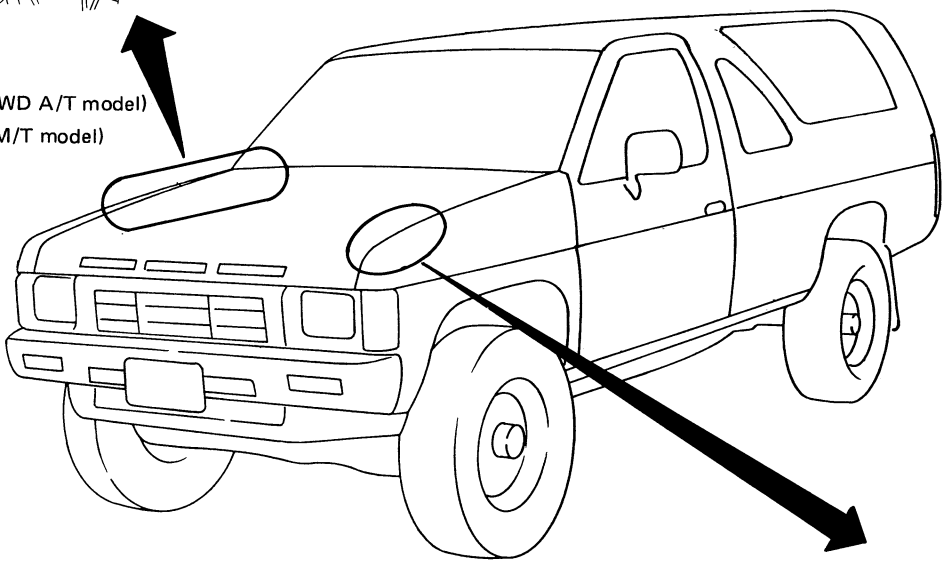
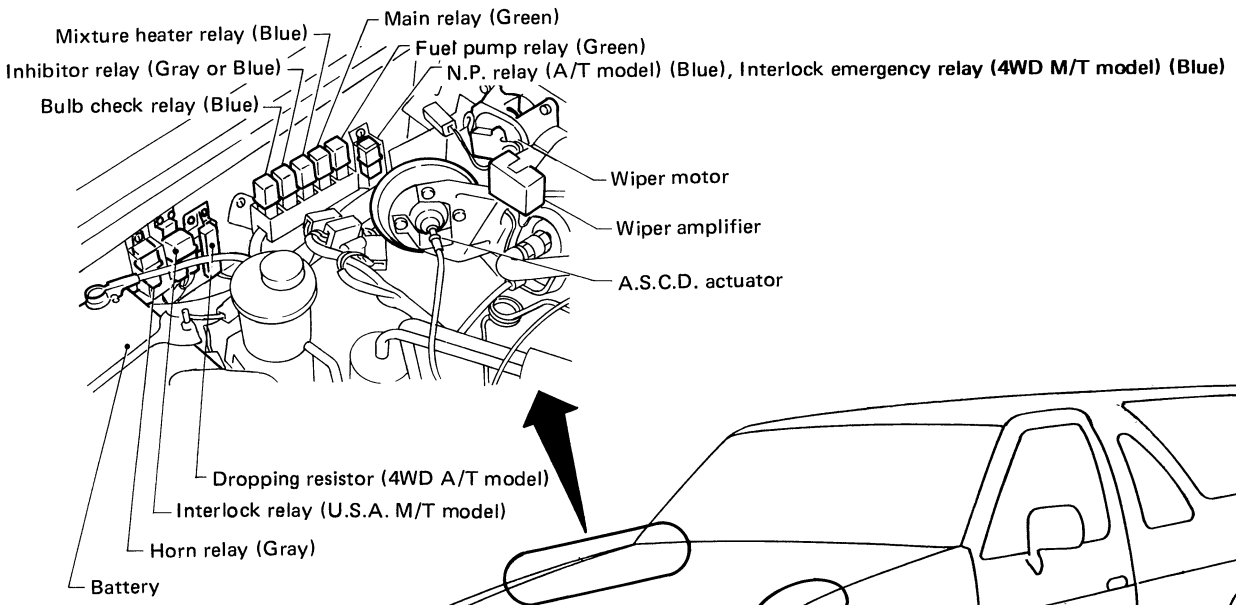

Air conditioner relay (Blue)

M/T model

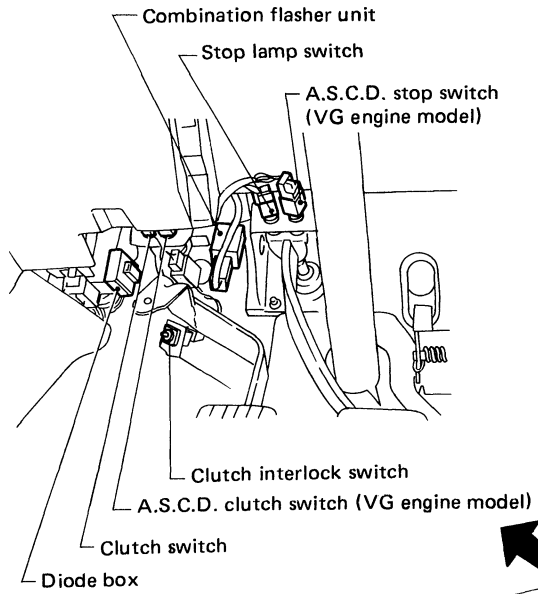

A/T model

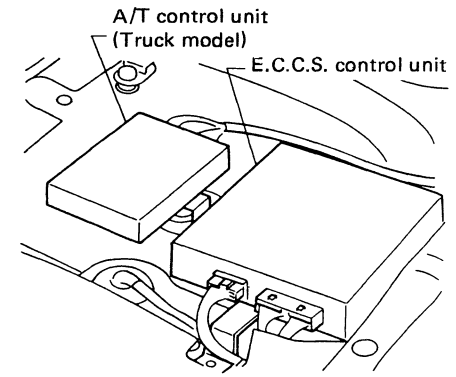
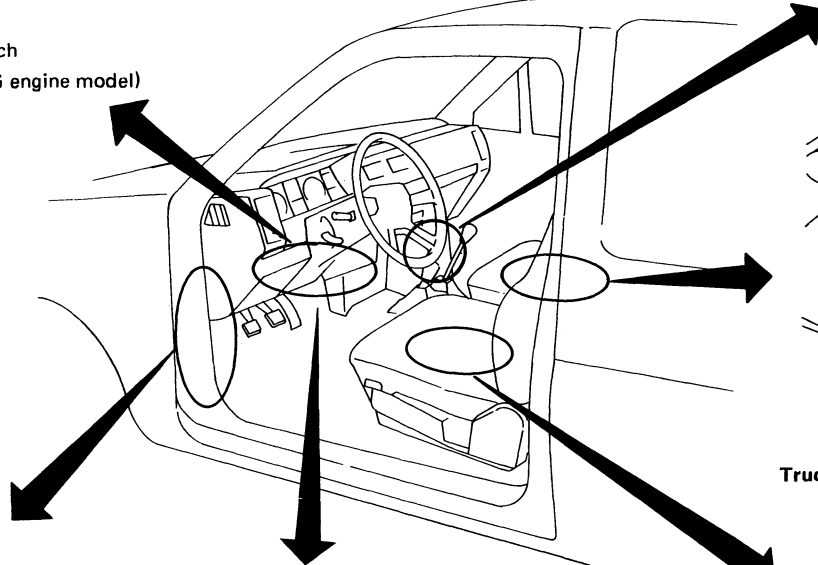
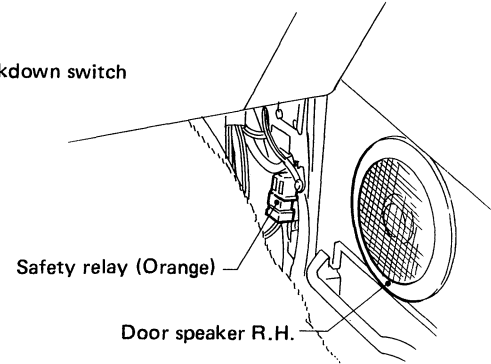
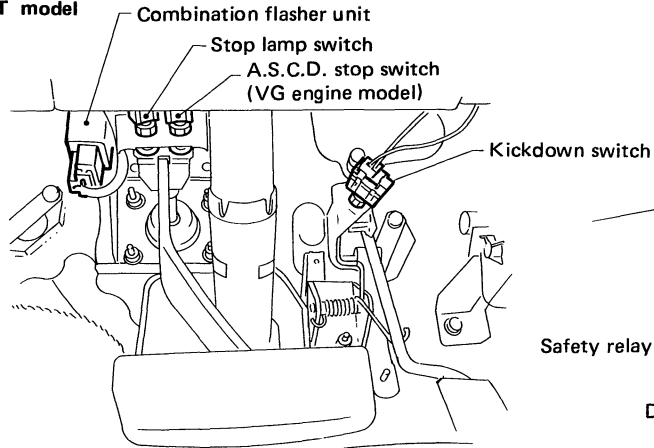

Truck model

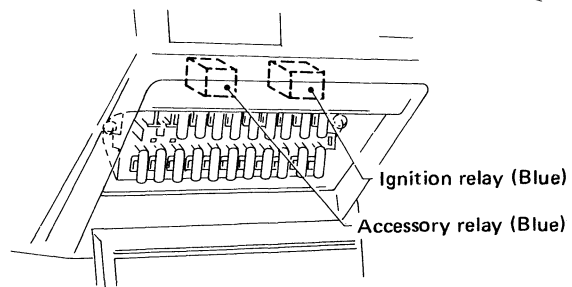
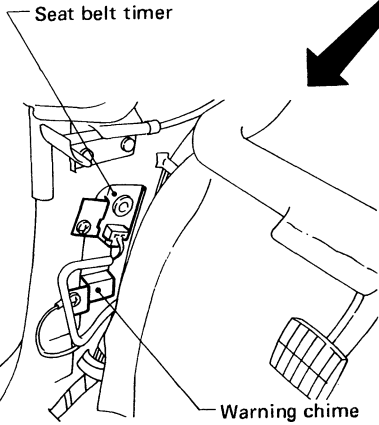
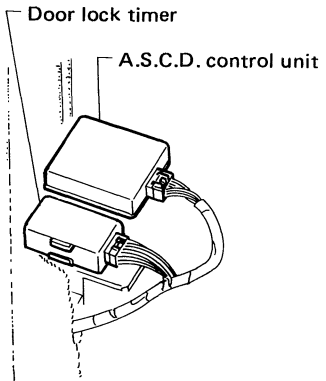

Passenger Compartment

LOCATION OF ELECTRICAL UNITS

LOCATION OF ELECTRICAL UNITS

Passenger Compartment (Cont'd)

VAN AND WAGON MODEL

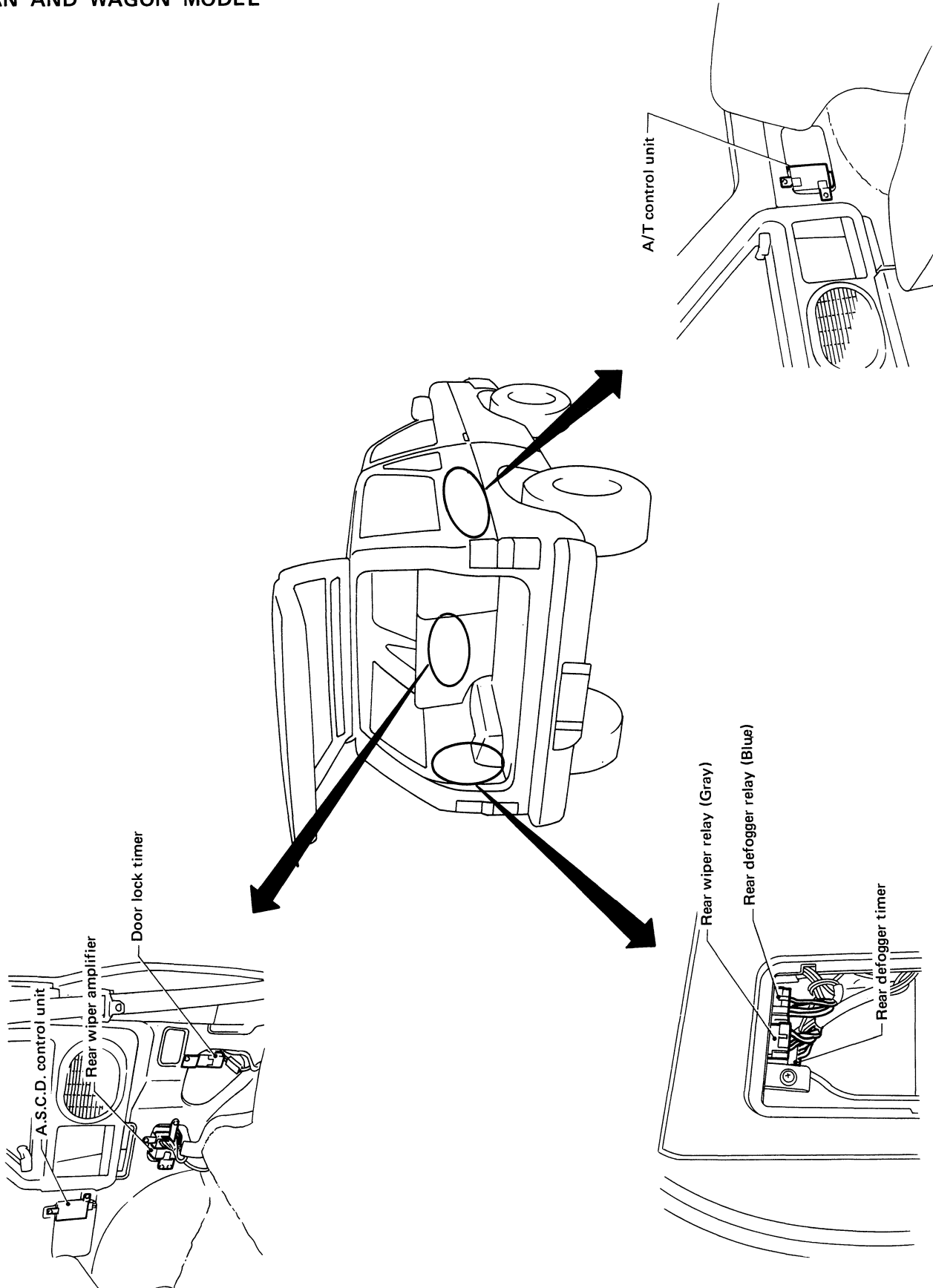

SEL5001

LOCATION OF ELECTRICAL UNITS

Note:

HARNESSES LAYOUT

Outline

TRUCK MODEL

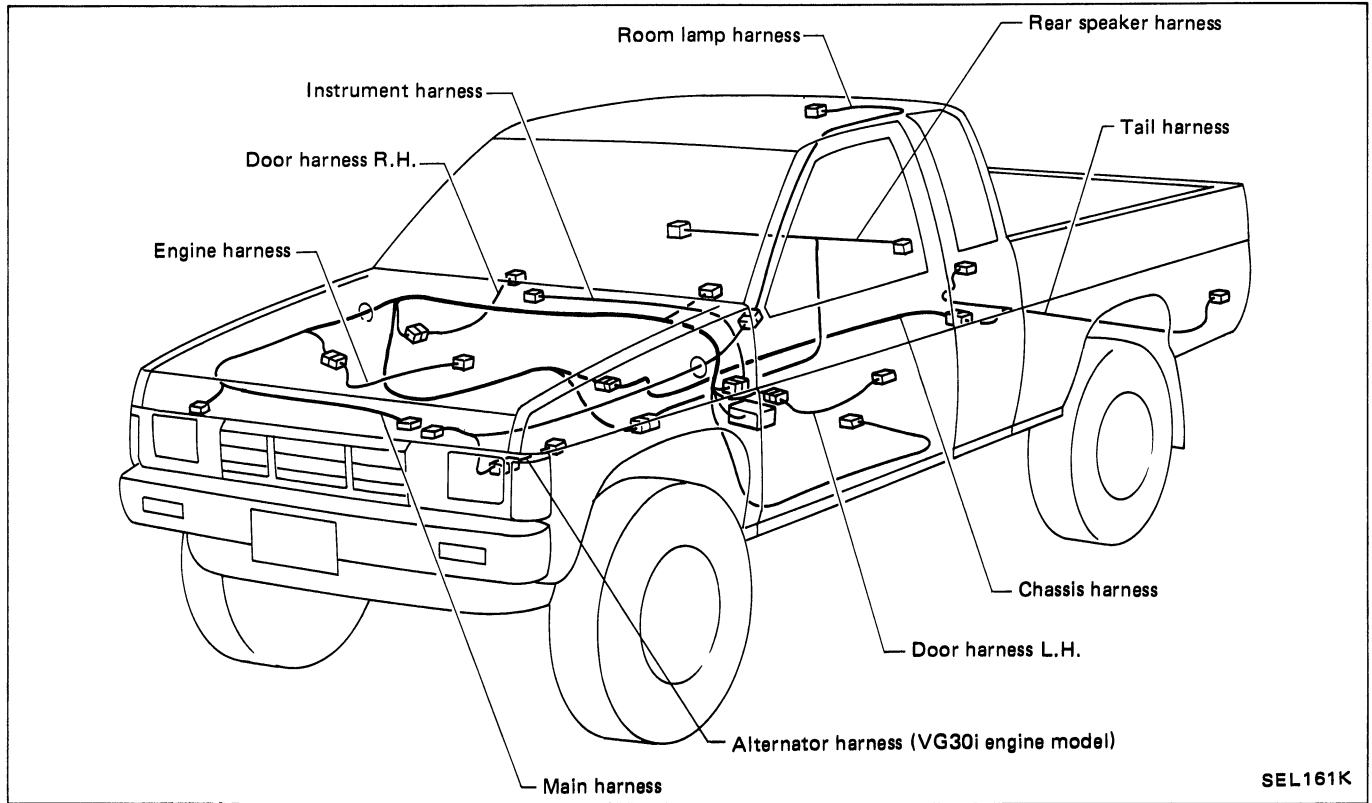

VAN AND WAGON MODEL

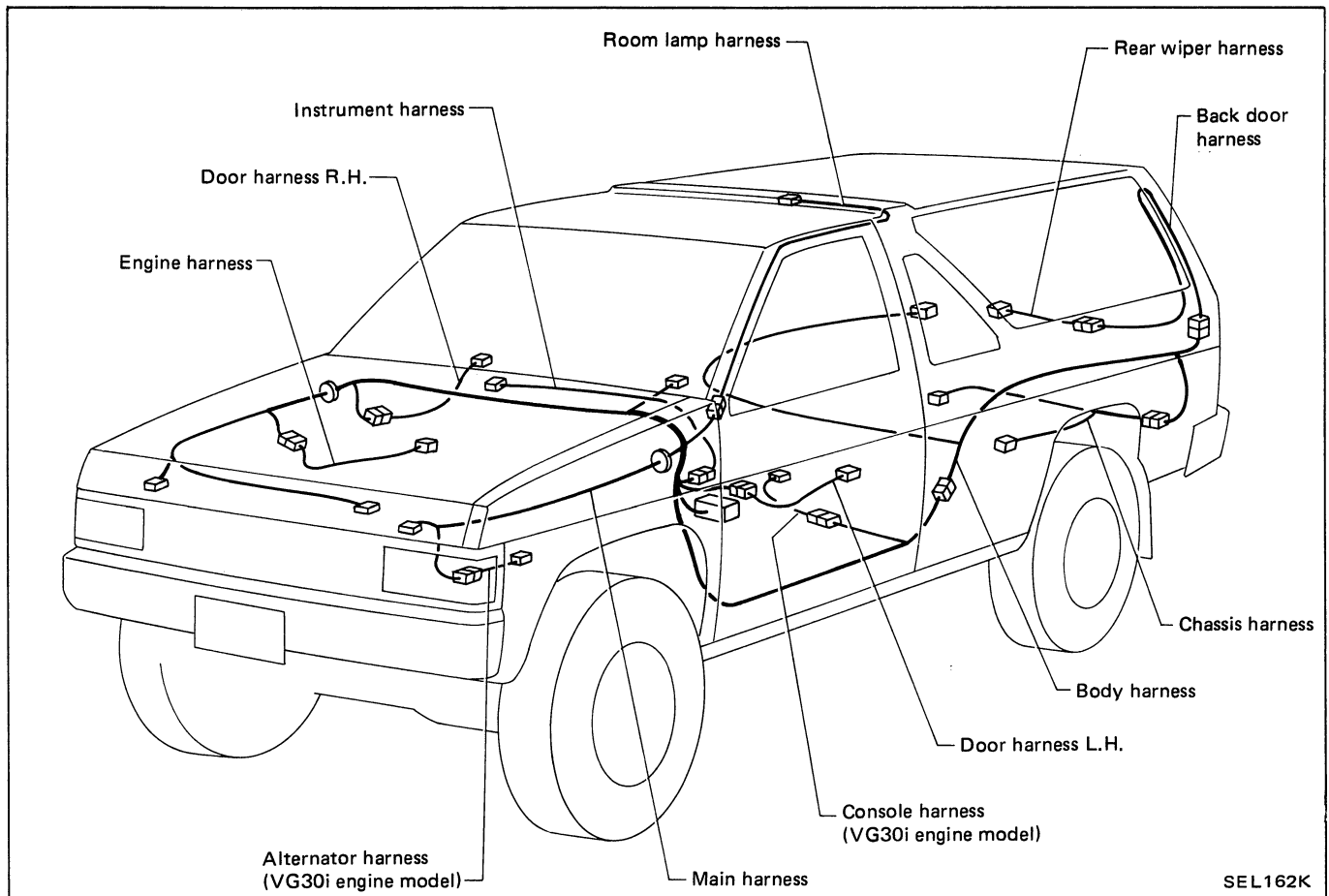

EL-94

Body ground

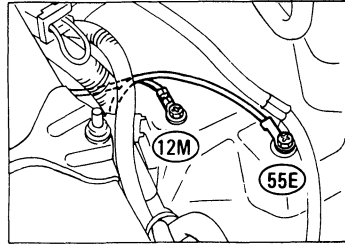

Engine ground

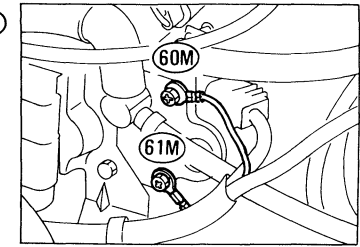

Engine ground

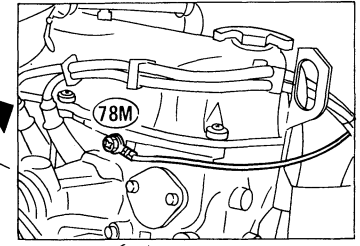

Engine ground

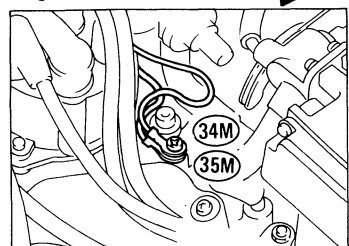

Resistor (40M)

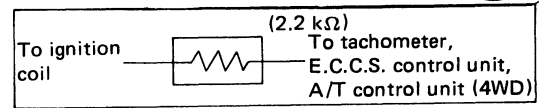

Main Harness

HARNES LAYOUT

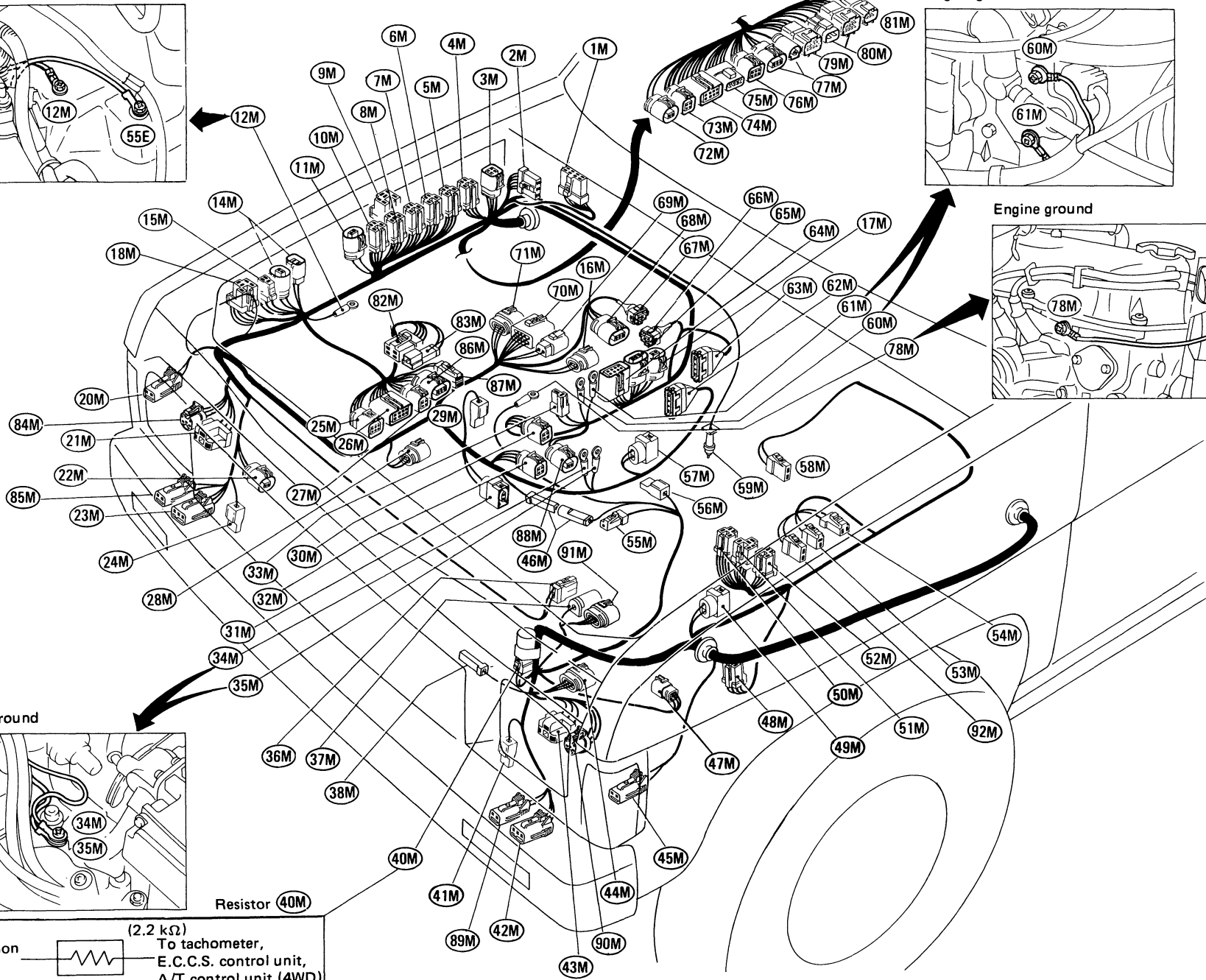

- 1M : Intermittent wiper amplifier (Van and Wagon)
 2M : Wiper motor
 3M : A.S.C.D. actuator (VG30i engine model)
 4M : N-P relay (A/T model)
 Interlock emergency relay (4WD M/T model for U.S.A.)
 5M : Fuel pump relay
 6M : Main relay
 7M : Mixture heater relay
 8M : Inhibitor relay (A/T model without A.S.C.D.)
 9M : Inhibitor relay (A/T model with A.S.C.D.)
 10M : Bulb check relay
 11M : Dropping resistor (4WD A/T model)
 12M : Body ground
 14M : Interlock relay (M/T model for U.S.A.)
 Adapter harness (M/T model)
 [Truck STD, VG30i engine E, 2WD SE (without A.S.C.D.) and Van for Canada]
 15M : Horn relay
 16M : Exhaust gas temperature sensor (VG30i engine model)
 17M : Exhaust gas temperature sensor (Z24i engine model)
 18M : Not used (4WD A/T model)
 20M : Side marker lamp R.H. ③
 Clearance lamp R.H. ②
 21M : Headlamp R.H. ③
 22M : Low-pressure switch
 23M : Front combination lamp R.H. ③
 24M : Horn R.H.
 25M : To 57E (Z24i engine A/T model)
 26M : To 56E (Z24i engine M/T model)
 27M : To 22E (VG30i engine model)
 28M : Power steering oil pressure switch (VG30i engine model)
 29M : Thermal transmitter (VG30i engine model)
 30M : Crank angle sensor (Z24i engine model)
 31M : Cylinder head temperature sensor (VG30i engine model)
 32M : Crank angle sensor (VG30i engine model)
 33M : Mixture heater (Z24i engine model)
 34M : Engine ground (VG30i engine model)
 35M : Engine ground (VG30i engine model)
 36M : To 33E (VG30i engine model)
 37M : To 32E (VG30i engine model)
 38M : Not used
 40M : Resistor & condenser
 41M : Horn L.H.
 42M : Front combination lamp L.H. ③
 43M : Headlamp L.H. ③
 44M : Ignition coil (Exhaust side: Z24i engine model)
 45M : Side marker lamp L.H. ③
 Clearance lamp L.H. ②
 46M : Joint connector (VG30i engine model)
 47M : Ignition coil
 48M : Air conditioner relay
 49M : A.I.V. solenoid (Z24i engine 2WD and VG30i engine model)
 50M : A.S.C.D. relay (VG30i engine model)
 51M : A/T indicator relay
 52M : Blower signal relay (VG30i engine model)
 53M : Washer motor
 54M : Washer level switch
 55M : Compressor
 56M : Distributor
 57M : E.G.R. cut solenoid (VG30i engine model)
 58M : Brake fluid level switch
 59M : Exhaust gas sensor (Z24i engine model)
 60M : Engine ground (Z24i engine model)
 61M : Engine ground (Z24i engine model)
 62M : Air flow meter (VG30i engine model)
 63M : Air flow meter (Z24i engine model)
 64M : Injector solenoid (Z24i engine model)
 65M : Throttle sensor (Z24i engine model)
 66M : Throttle valve switch (Z24i engine model)
 67M : Throttle valve switch (VG30i engine model)
 68M : Throttle sensor (VG30i engine model)
 69M : Mixture heater (VG30i engine model)
 70M : Injector solenoid (VG30i engine model)
 71M : To 12E (4WD A/T model)
 72M : To 53E (Z24i engine M/T model)
 73M : To 52E (Z24i engine A/T model)
 74M : To 51E (Z24i engine A/T model)
 To 3E (VG30i engine 2WD A/T model)
 75M : To 2E (VG30i engine 2WD A/T model)
 76M : To 1E (VG30i engine M/T model)
 77M : Exhaust gas sensor (VG30i engine model)
 78M : Engine ground (Z24i engine model)
 79M : To sub harness (4WD A/T model)
 80M : Inhibitor switch (4WD A/T model)
 81M : Revolution sensor (4WD A/T model)
 82M : Fusible link
 83M : Fusible link
 84M : Headlamp R.H. ②
 85M : Front turn signal lamp R.H. ②
 86M : To 23E (VG30i engine model) (Van and Wagon)
 87M : To 58E (Z24i engine model)
 88M : E.G.R. cut solenoid (Z24i engine model)
 89M : Front turn signal lamp L.H. ②
 90M : Headlamp L.H. ②
 91M : To 31E (VG30i engine model) (Van and Wagon)
 92M : Rear washer motor (Van and Wagon)
 ② : Van, Wagon and Truck for U.S.A. except STD and VG30i engine 2WD E model
 ③ : Truck for Canada and Truck STD and VG30i engine 2WD E model for U.S.A.

Diode (264M)

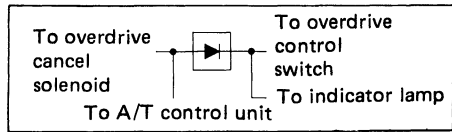

(For A/T system)

Diode (265M)

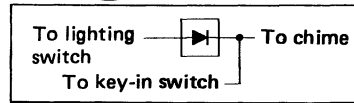

(For warning chime system)

EL-96

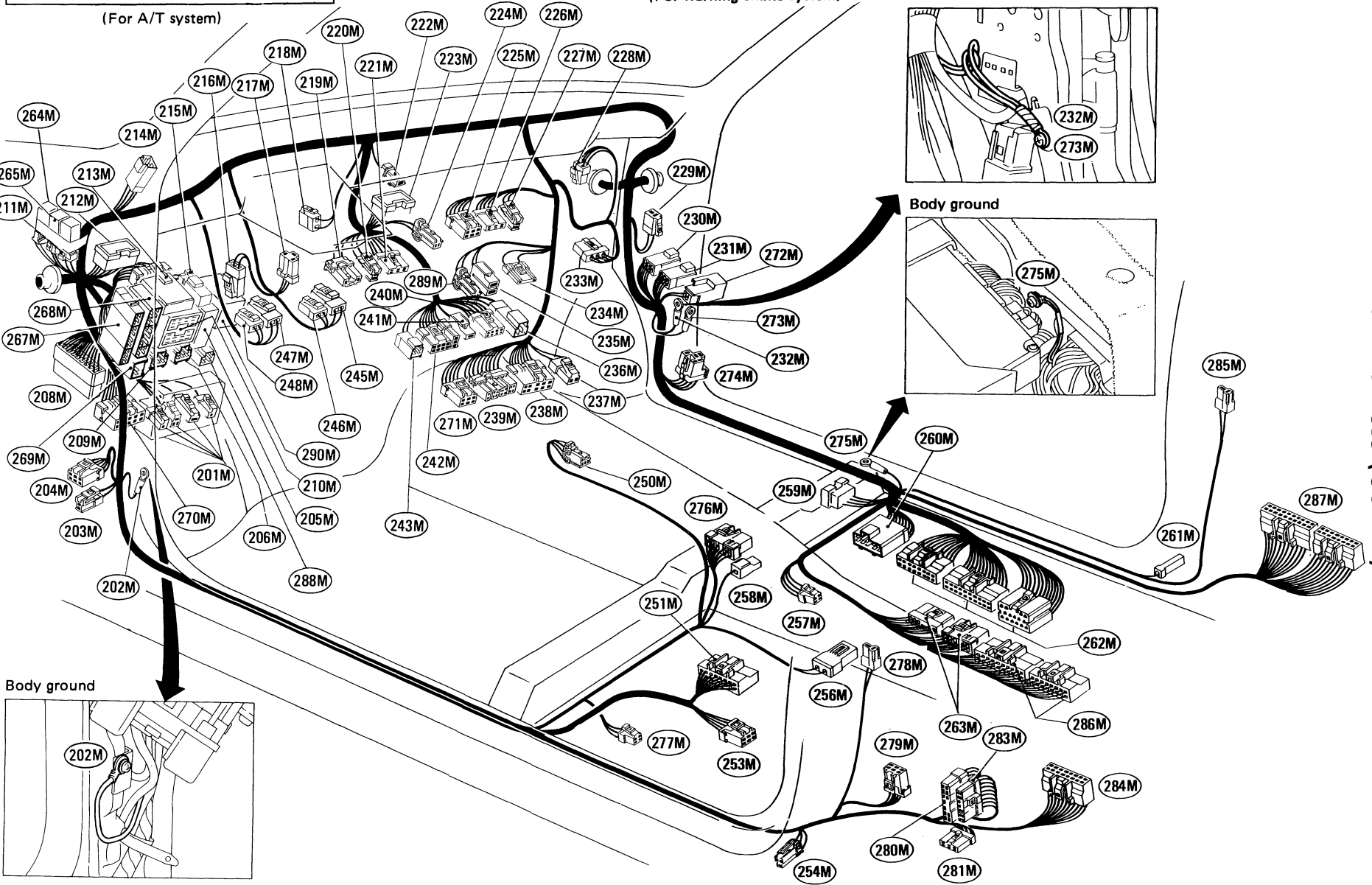

Body ground

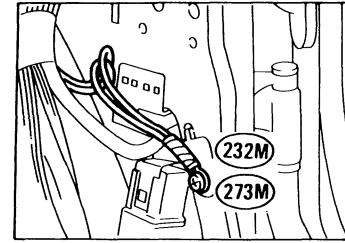

Body ground

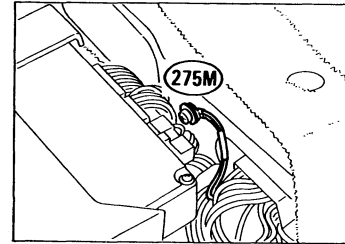

Body ground

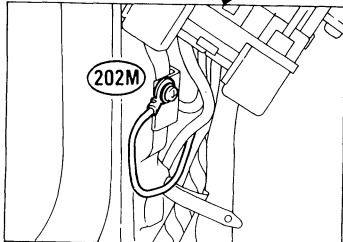

HARNES LAYOUT
Main Harness (Cont'd)

- (201M) : Fuse block
- (202M) : Body ground
- (203M) : Warning chime
- (204M) : Seat belt timer
- (205M) : Diode (VG30i engine model)
- (206M) : To door harness L.H. (Blue)
- (208M) : Check connector
- (209M) : To door harness L.H. (White)
- (210M) : To (11) (S.M.J.) (Van, Wagon and VG30i engine Truck model)
- (211M) : Diode (VG30i engine M/T and 4WD A/T model)
- (212M) : Joint connector C (VG30i engine model)
- (213M) : Diode (A/T model)
- (214M) : To room lamp harness
- (215M) : Diode (Z24i engine M/T model)
- (216M) : Clutch interlock switch (M/T model)
- (217M) : Combination flasher unit
- (218M) : Kickdown switch (A/T model)
- (219M) : A/T indicator illumination (Column shift A/T model)
- (220M) : Key-in switch
- (221M) : Ignition switch
- (222M) : Parking brake switch (Stick type)
- (223M) : Joint connector B (VG30i engine model)
- (224M) : Overdrive control switch (Column shift A/T model)
- (225M) : Air conditioner switch
- (226M) : Fan switch
- (227M) : Heater illumination
- (228M) : Thermo control amplifier
- (229M) : Blower motor
- (230M) : To door harness R.H. (Blue)
- (231M) : To door harness R.H. (White)
- (232M) : Body ground
- (233M) : Resistor
- (234M) : Ash tray illumination
- (235M) : Cigarette lighter
- (236M) : Intermittent wiper volume
- (237M) : Audio illumination
- (238M) : Radio
- (239M) : Amplifier (Van and Wagon)
- (240M) : Wiper switch
- (241M) : Horn switch
- (242M) : Lighting switch
- (243M) : A.S.C.D. switch (VG30i engine model)
- (245M) : A.S.C.D. stop switch (VG30i engine model)
- (246M) : Stop lamp switch
- (247M) : A.S.C.D. clutch switch (VG30i engine M/T model)
- (248M) : Clutch switch (M/T model)
- (250M) : Overdrive control switch and A/T indicator lamp (Floor shift A/T model)
- (251M) : A.S.C.D. control unit (VG30i engine Truck model)
- (253M) : Door lock timer (Truck)
- (254M) : Door switch L.H.

- (256M) : Seat belt switch
- (257M) : To rear speaker harness (Truck)
- (258M) : Parking brake switch (Center lever type)
- (259M) : Joint connector A
- (260M) : To (1C) (Truck)
- (261M) : Door switch R.H.
- (262M) : E.C.C.S. control unit
- (263M) : A/T control unit (2WD A/T model)
- (264M) : Diode (Z24i engine A/T model)
- (265M) : Diode
- (267M) : To (24I) (Z24i engine Truck model)
- (268M) : To (25I) (Z24i engine Truck model)
- (269M) : To door harness L.H.
- (270M) : To (23I) (VG30i engine Van and Wagon model)
- (271M) : Radio
- (272M) : To door harness R.H.
- (273M) : Body ground

- (274M) : Safety relay
- (275M) : Body ground
- (276M) : To console harness (VG30i engine Van and Wagon model)
- (277M) : Heating seat (VG30i engine Van and Wagon model)
- (278M) : Rear speaker L.H. (Van and Wagon)
- (279M) : Door lock timer (Van and Wagon)
- (280M) : To (1B) (Van and Wagon)
- (281M) : To (5B) (Van and Wagon)
- (283M) : To (2B) (Van and Wagon)
- (284M) : A.S.C.D. control unit (VG30i engine Van and Wagon model)
- (285M) : Rear speaker R.H. (Van and Wagon)
- (286M) : A/T control unit (4WD A/T Truck model)
- (287M) : A/T control unit (4WD A/T Van and Wagon model)
- (288M) : To (26I) (Z24i engine Truck model for Canada)
- (289M) : Cigarette lighter illumination
- (290M) : Diode (VG30i engine 4WD A/T model)

Diode (205M)

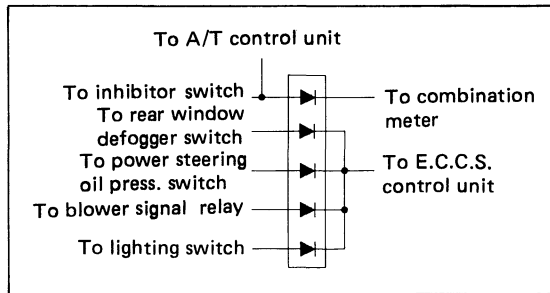

(For E.C.C.S., and A/T control system)

Diode (211M) (4WD A/T model)

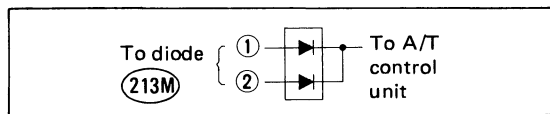

(For A/T control system)

Diode (211M) and (215M) (M/T model)

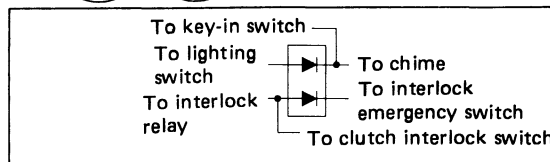

(For starting and warning chime system)

Diode (213M) (2WD A/T model)

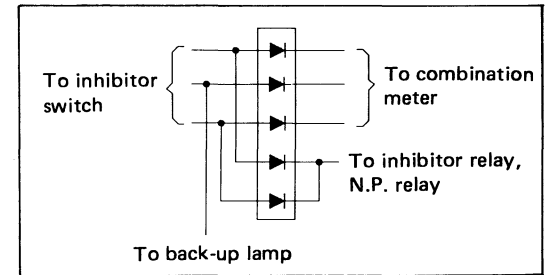

(For A/T control and indicator system)

Diode (213M) (4WD A/T model)

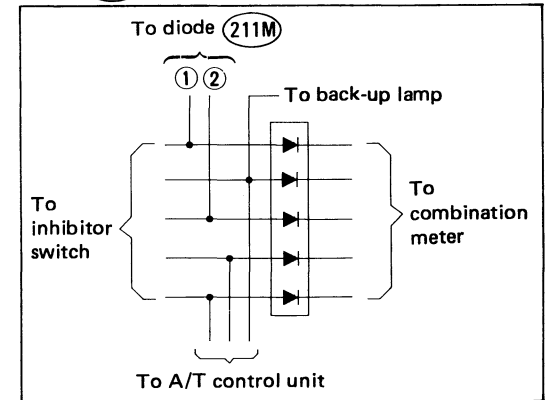

(For A/T control system)

Diode (2I)

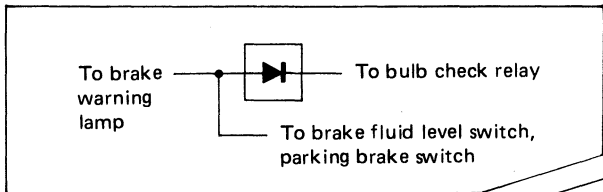

(For warning lamp system)

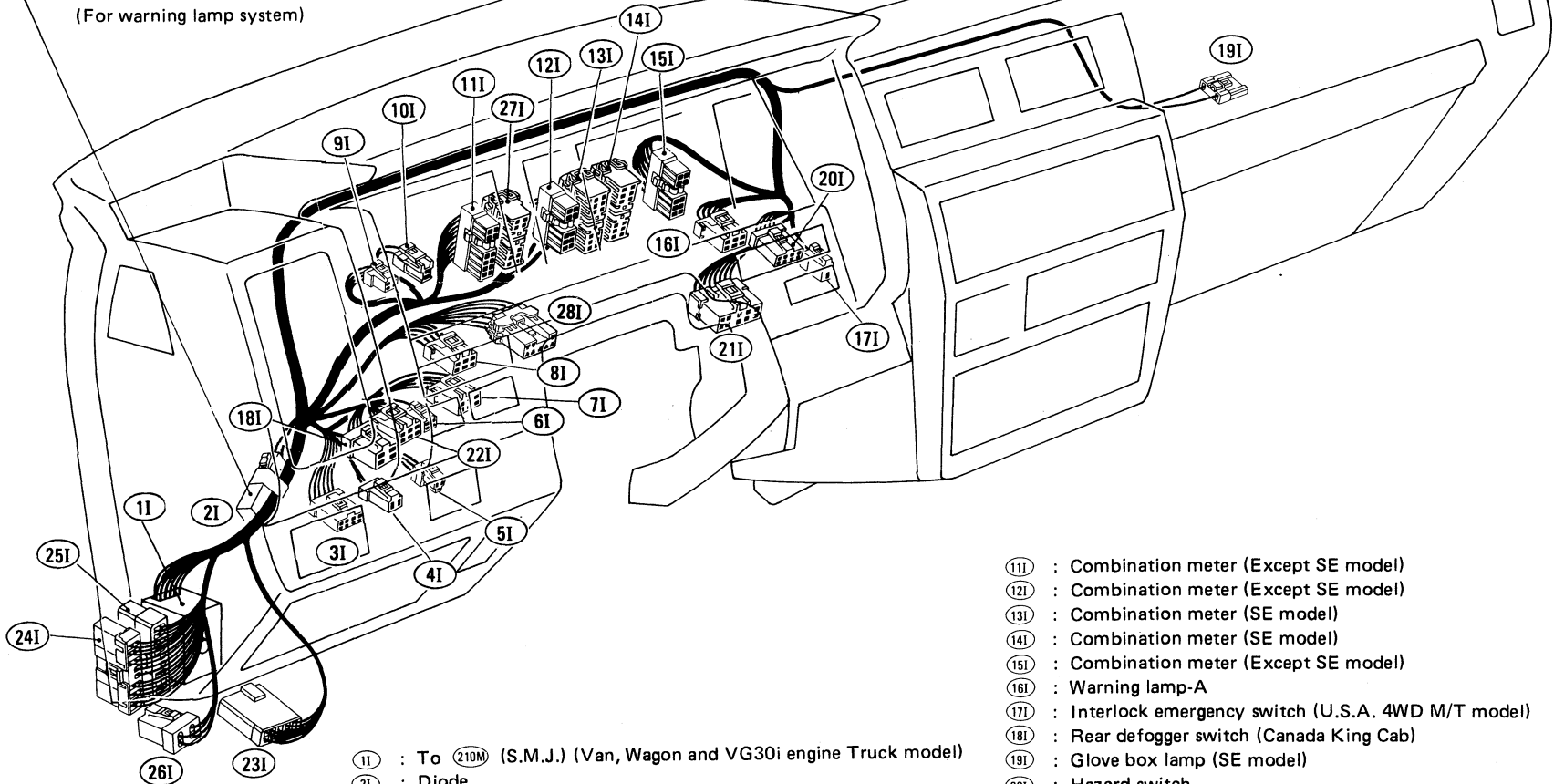

- (1I) : To (210M) (S.M.J.) (Van, Wagon and VG30i engine Truck model)
- (2I) : Diode
- (3I) : Remote control mirror switch (SE model)
- (4I) : Back window opener switch (Van and Wagon SE model)
- (5I) : Illumination control rheostat
- (6I) : Not used
- (7I) : A.S.C.D. switch [XE A/T (Van and Wagon) and SE models]
- (8I) : Warning lamp-B (Except SE model)
- (9I) : Tachometer (Except SE model)
- (10I) : Clock

- (11I) : Combination meter (Except SE model)
- (12I) : Combination meter (Except SE model)
- (13I) : Combination meter (SE model)
- (14I) : Combination meter (SE model)
- (15I) : Combination meter (Except SE model)
- (16I) : Warning lamp-A
- (17I) : Interlock emergency switch (U.S.A. 4WD M/T model)
- (18I) : Rear defogger switch (Canada King Cab)
- (19I) : Glove box lamp (SE model)
- (20I) : Hazard switch
- (21I) : Rear wiper switch (Van and Wagon SE model)
- (22I) : Rear defogger switch (Van and Wagon)
- (23I) : To (270M) (Van and Wagon SE model)
- (24I) : To (267M) (Z24i engine Truck model)
- (25I) : To (268M) (Z24i engine Truck model)
- (26I) : To (288M) (Z24i engine Truck model for Canada)
- (27I) : Combination meter (SE model)
- (28I) : Warning lamp-B (SE model)

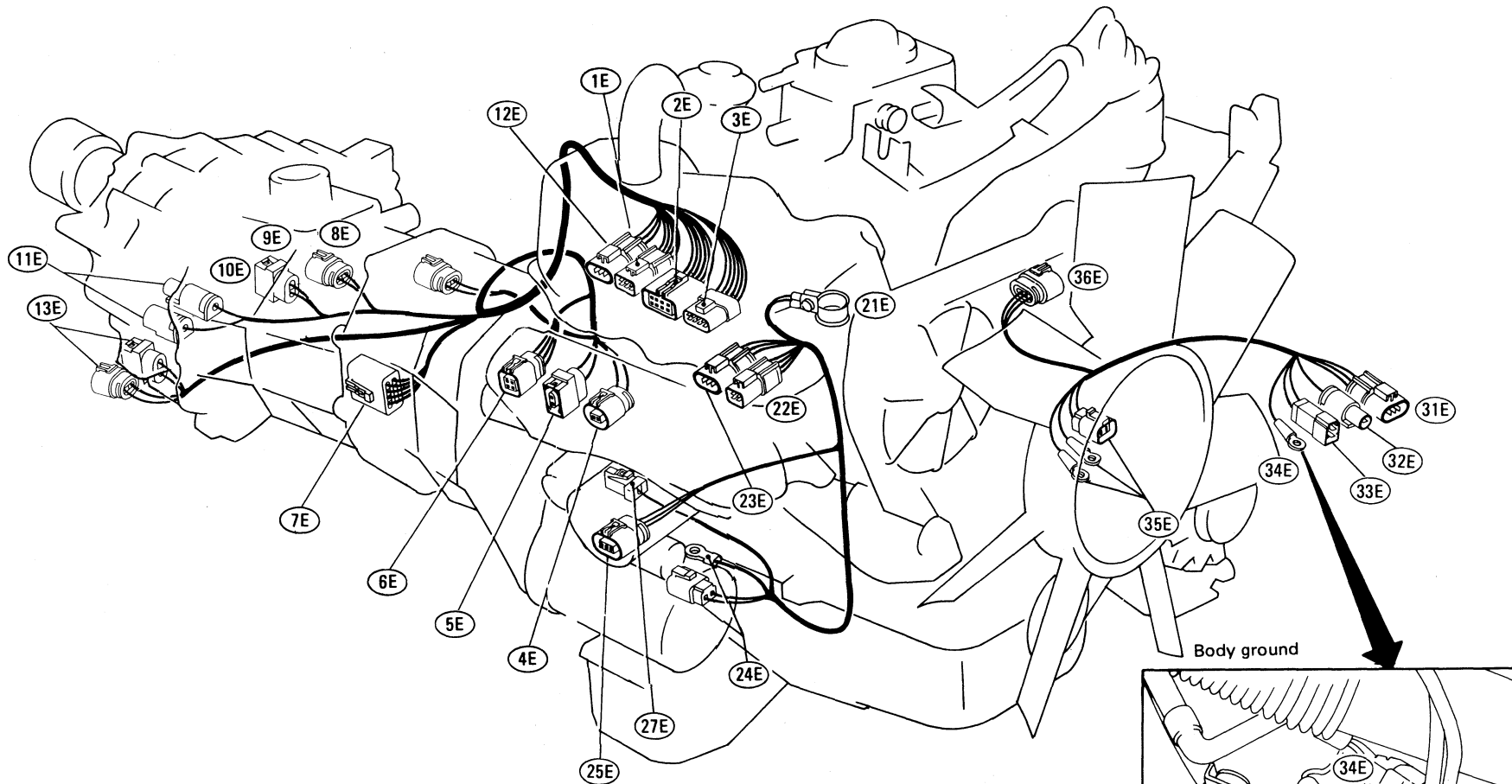

- ①E : To ⑦6M (M/T model)
- ②E : To ⑦5M (2WD A/T model)
- ③E : To ⑦4M (2WD A/T model)
- ④E : Lock-up solenoid (2WD A/T model)
- ⑤E : Overdrive cancel solenoid (2WD A/T model)
- ⑥E : Shift switch (2WD A/T model)
- ⑦E : Inhibitor switch (2WD A/T model)
- ⑧E : Downshift solenoid (2WD A/T model)
- ⑨E : Back-up lamp switch (M/T model)
- ⑩E : Neutral switch (M/T model)
- ⑪E : Transfer switch (4WD M/T model)
- ⑫E : To ⑦2M (4WD A/T model)
- ⑬E : Transfer switch (4WD A/T model)

Battery cable

- ⑳E : Battery
- ㉑E : To ②7M
- ㉒E : To ⑧6M (Van and Wagon)
- ㉓E : Starter motor
- ㉔E : Front shock absorber R.H. (Van and Wagon)
- ㉕E : Oil pressure switch

Alternator harness

- ③1E : To ⑨1M (Van and Wagon)
- ③2E : To ③7M
- ③3E : To ③6M
- ③4E : Body ground
- ③5E : Alternator
- ③6E : Front shock absorber L.H. (Van and Wagon)

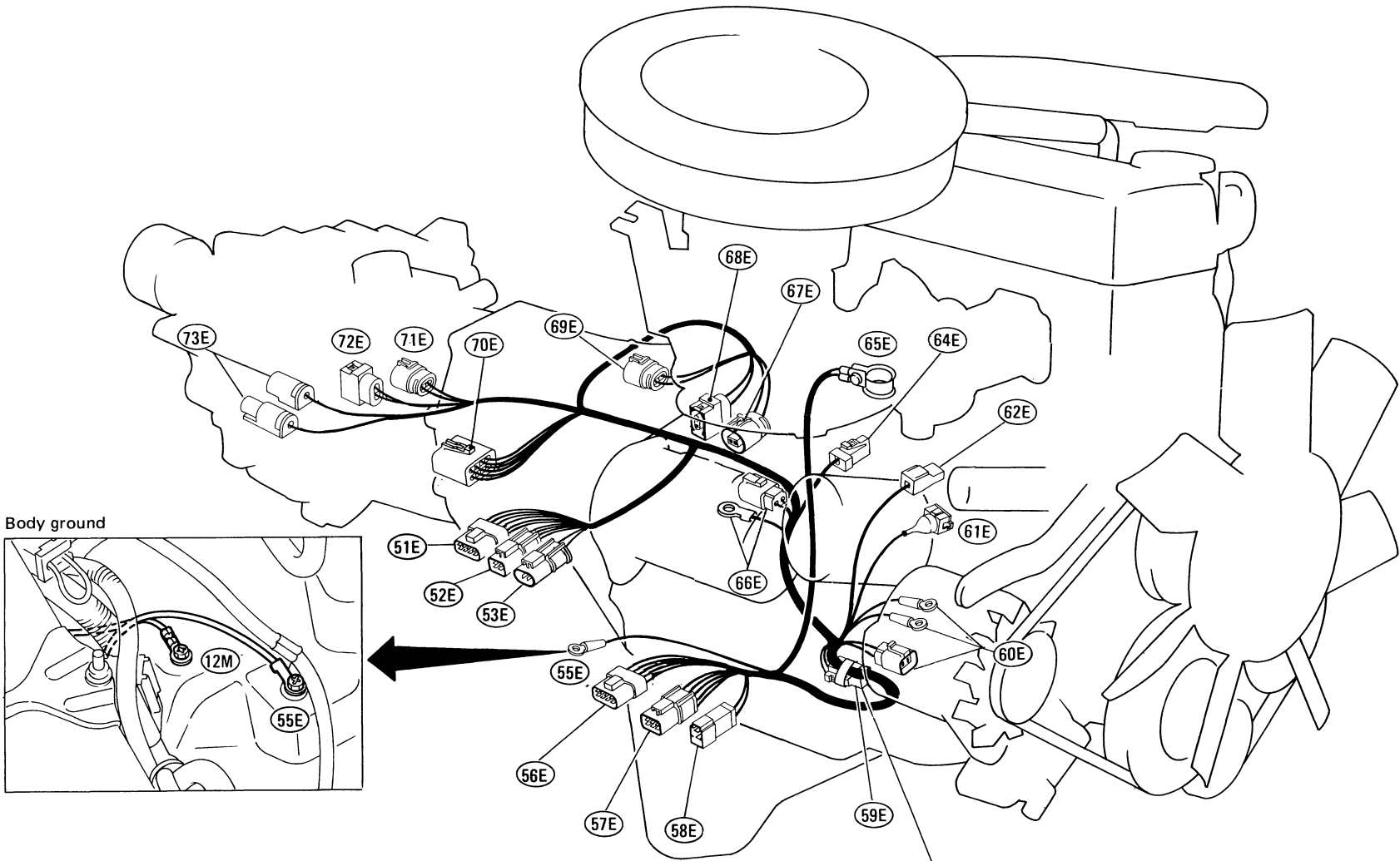

Body ground

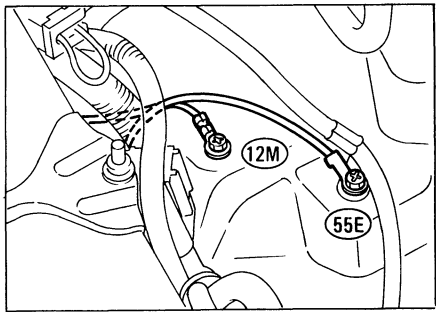

- ⑤1E : To ⑦4M (A/T model)
- ⑤2E : To ⑦3M (A/T model)
- ⑤3E : To ⑦2M (M/T model)
- ⑤5E : Body ground
- ⑤6E : To ②6M (M/T model)
- ⑤7E : To ②5M (A/T model)
- ⑤8E : To ⑧7H
- ⑤9E : Diode
- ⑥0E : Alternator
- ⑥1E : Water temperature sensor
- ⑥2E : Thermal transmitter

- ⑥4E : Oil pressure switch
- ⑥5E : Battery
- ⑥6E : Starter motor
- ⑥7E : Lock-up solenoid (A/T model)
- ⑥8E : Overdrive cancel solenoid (A/T model)
- ⑥9E : Downshift solenoid (A/T model)
- ⑦0E : Inhibitor switch (A/T model)
- ⑦1E : Back-up lamp switch (M/T model)
- ⑦2E : Neutral switch (M/T model)
- ⑦3E : Transfer switch (4WD model)

Diode ⑤9E

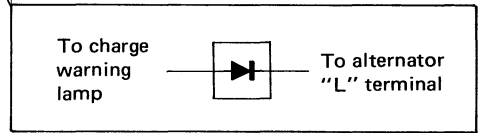

(For charging system)

Tail harness

- ①T : To ④C
- ②T : License lamp R.H. (With step bumper)
- ③T : Rear combination lamp R.H.
- ④T : License lamp R.H. (Without step bumper)
- ⑤T : License lamp L.H. (Without step bumper)
- ⑥T : License lamp L.H. (With step bumper)
- ⑦T : Rear combination lamp L.H.

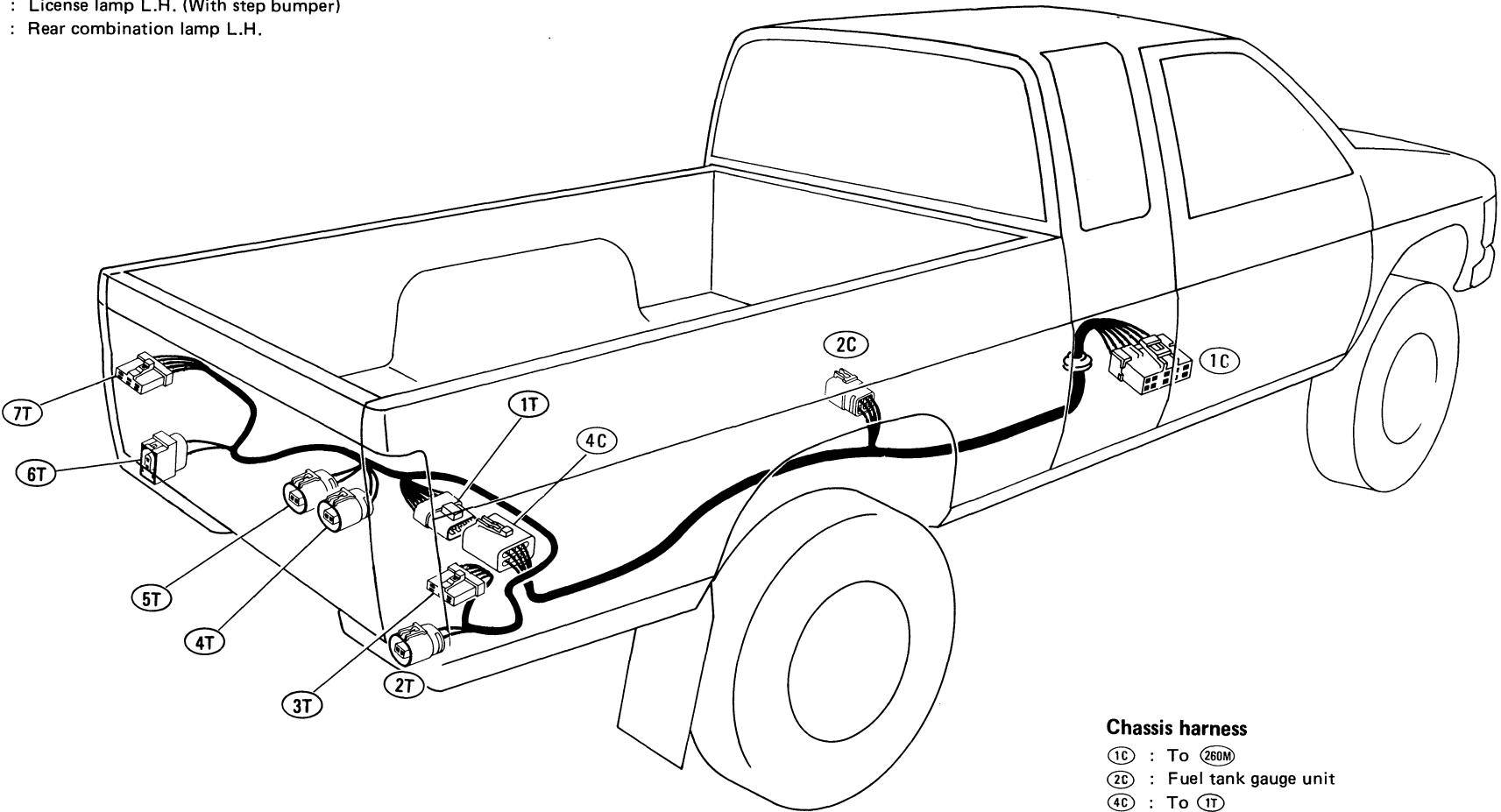

Chassis harness

- ①C : To ②60N
- ②C : Fuel tank gauge unit
- ④C : To ①T

VAN AND WAGON MODEL

Body and Chassis Harness

Body harness

- 1B : To 280M
- 2B : To 283M
- 4B : Rear wiper amplifier (SE model)
- 5B : To 281M
- 6B : Body ground
- 7B : To 1D
- 8B : Rear defogger relay
- 9B : Diode

Body ground

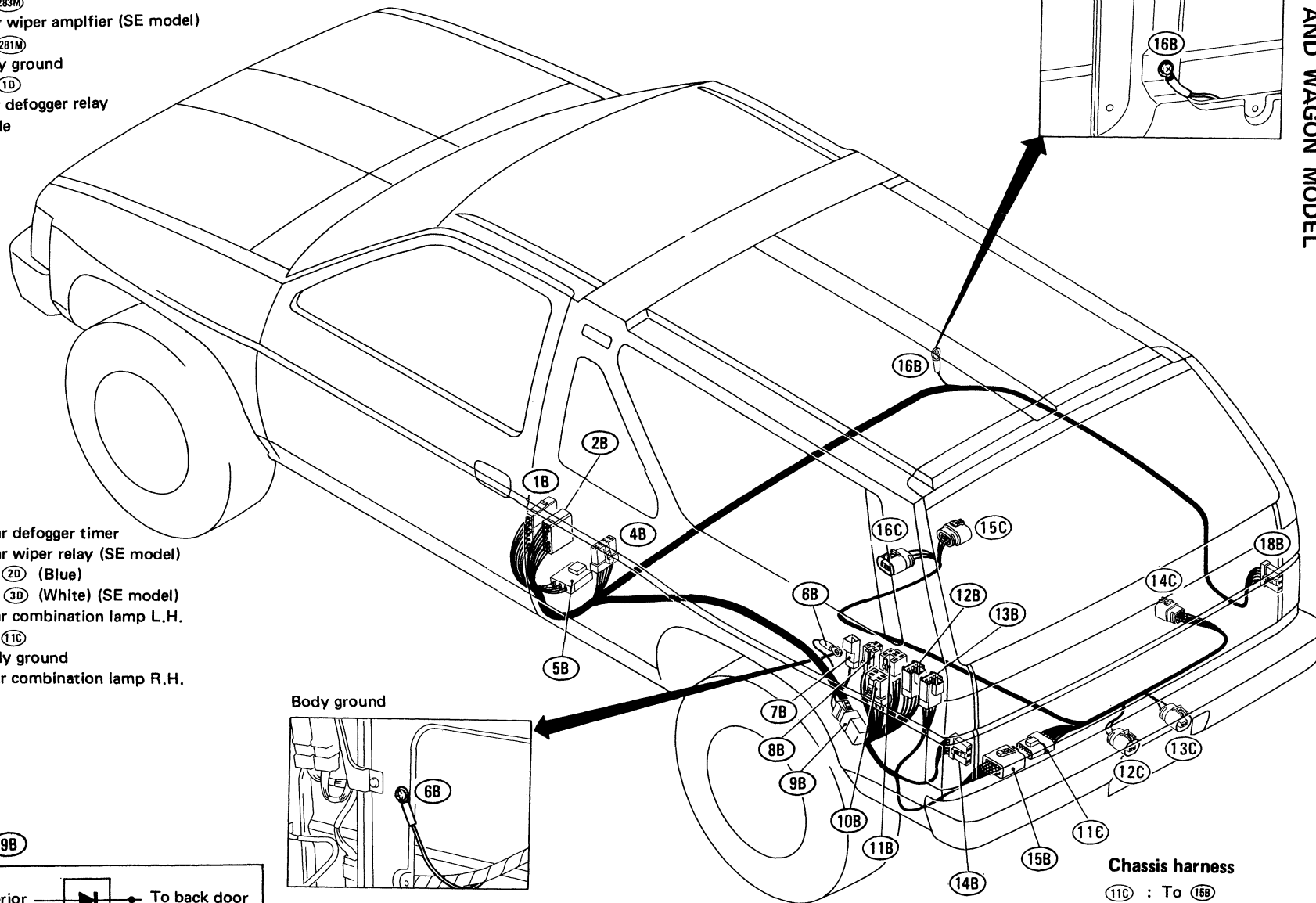
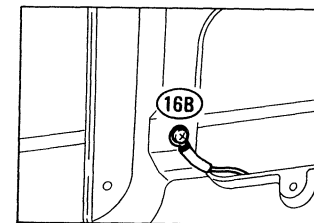

- 10B : Rear defogger timer
- 11B : Rear wiper relay (SE model)
- 12B : To 2D (Blue)
- 13B : To 3D (White) (SE model)
- 14B : Rear combination lamp L.H.
- 16B : To 11C
- 16B : Body ground
- 18B : Rear combination lamp R.H.

Body ground

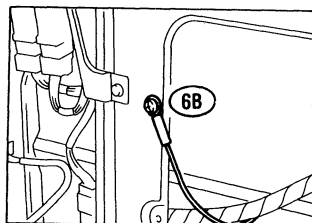

Diode 9B

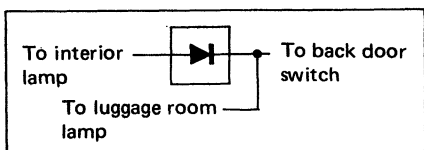

(For interior lamp system)

Chassis harness

- 11C : To 16B
- 12C : License lamp L.H.
- 13C : License lamp R.H.
- 14C : Fuel tank gauge unit
- 15C : Rear shock absorber R.H.
- 16C : Rear shock absorber L.H.

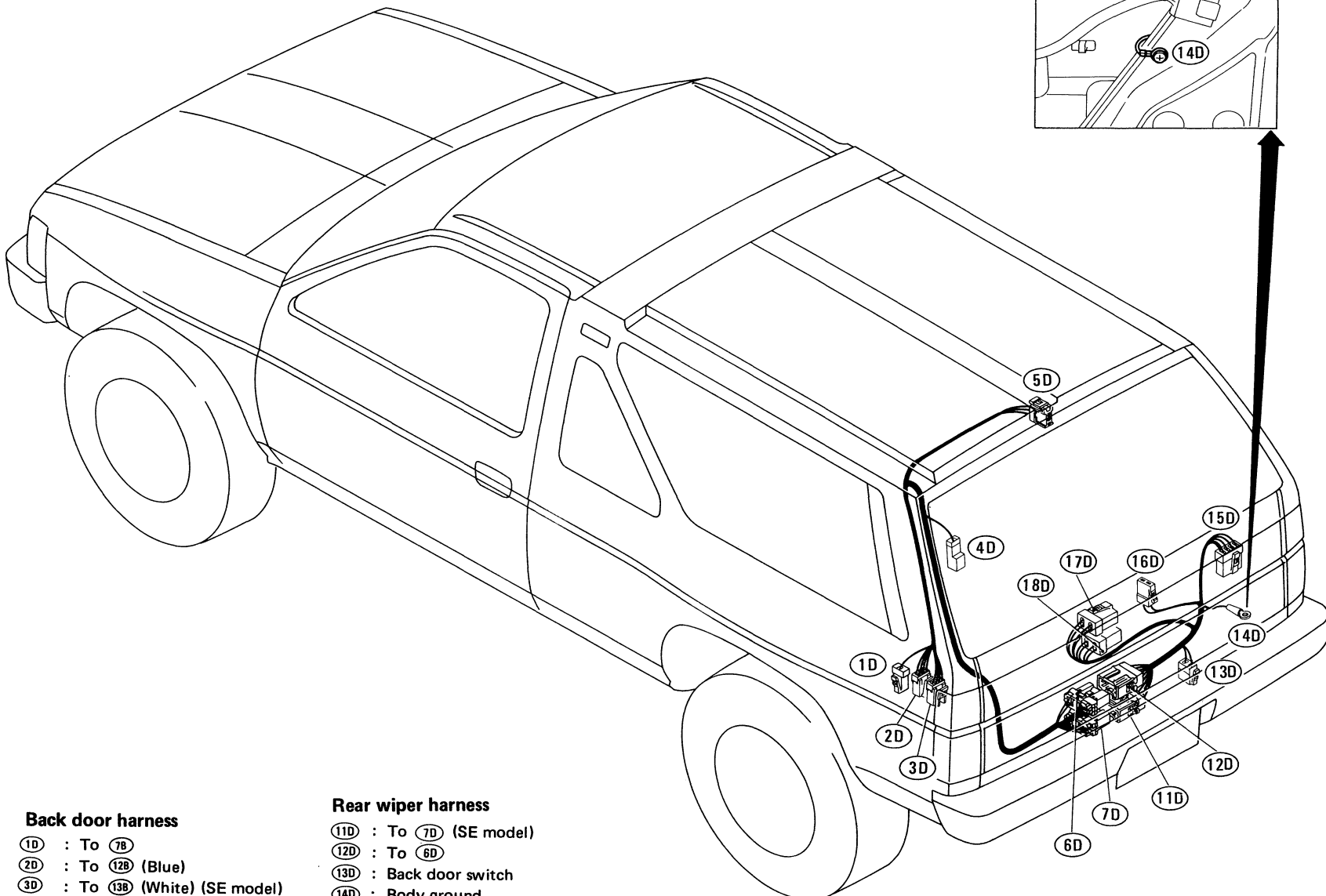

Back door harness

- ①D : To ⑦B
- ②D : To ⑫B (Blue)
- ③D : To ⑬B (White) (SE model)
- ④D : Rear defogger
- ⑤D : Luggage room lamp
- ⑥D : To ⑫D
- ⑦D : To ⑪D (SE model)

Rear wiper harness

- ⑪D : To ⑦D (SE model)
- ⑫D : To ⑥D
- ⑬D : Back door switch
- ⑭D : Body ground
- ⑮D : Rear wiper motor (SE model)
- ⑯D : Glass hatch switch (SE model)
- ⑰D : Glass hatch opener solenoid (SE model)
- ⑱D : Door lock actuator (SE model)

Body ground

SPECIAL SERVICE TOOL

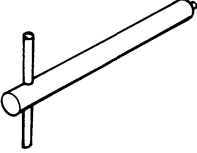
Tool number	Tool name
(J36126)	Washer nozzle adjusting tool 

SUPER MULTIPLE JUNCTION (S.M.J.)

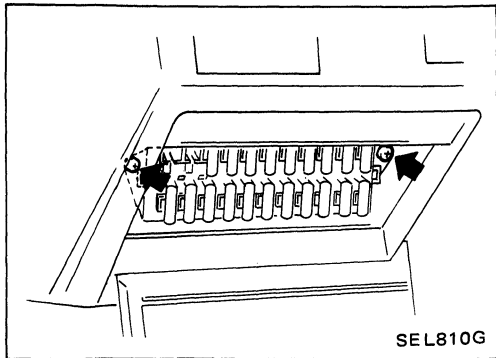

REMOVAL

- Remove fuse block retaining screws to gain access to S.M.J.
- Slide fuse block to the side, and remove S.M.J. retaining bolts to detach S.M.J.

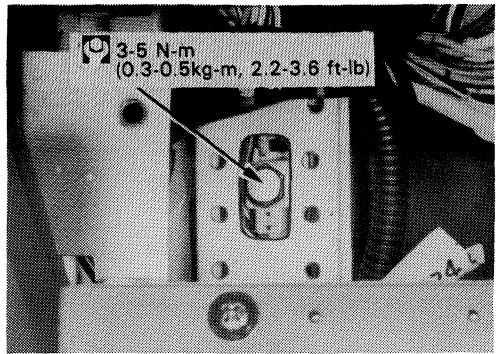
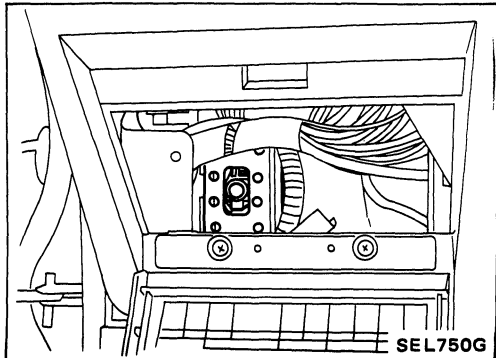

INSTALLATION

To install S.M.J., tighten bolts until orange "fulltight" mark appears and then retighten to specified torque as required.

 : 3 - 5 N·m (0.3 - 0.5 kg·m, 2.2 - 3.6 ft·lb)

CAUTION:

Do not overtighten bolts, otherwise, bolts may be damaged.

SUPER MULTIPLE JUNCTION (S.M.J.)

Terminal Arrangement (Model D21 series)

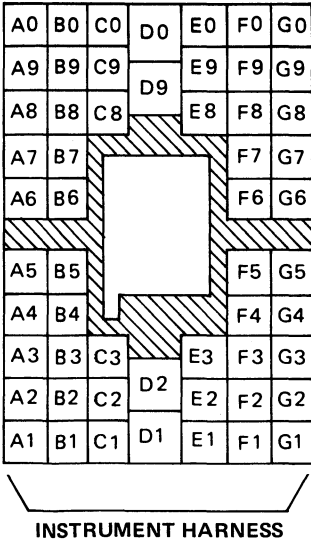
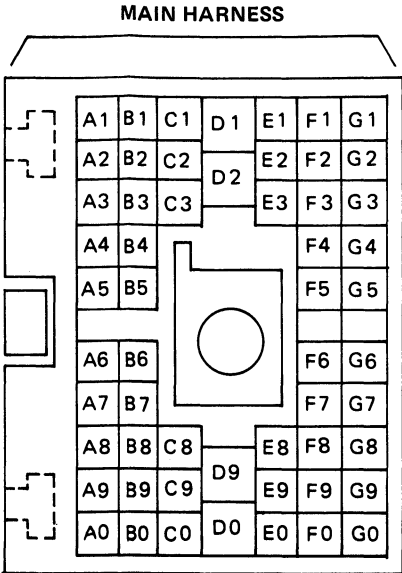

SEL292H

1989 NISSAN TRUCK/PATHFINDER CIRCUIT DIAGRAM

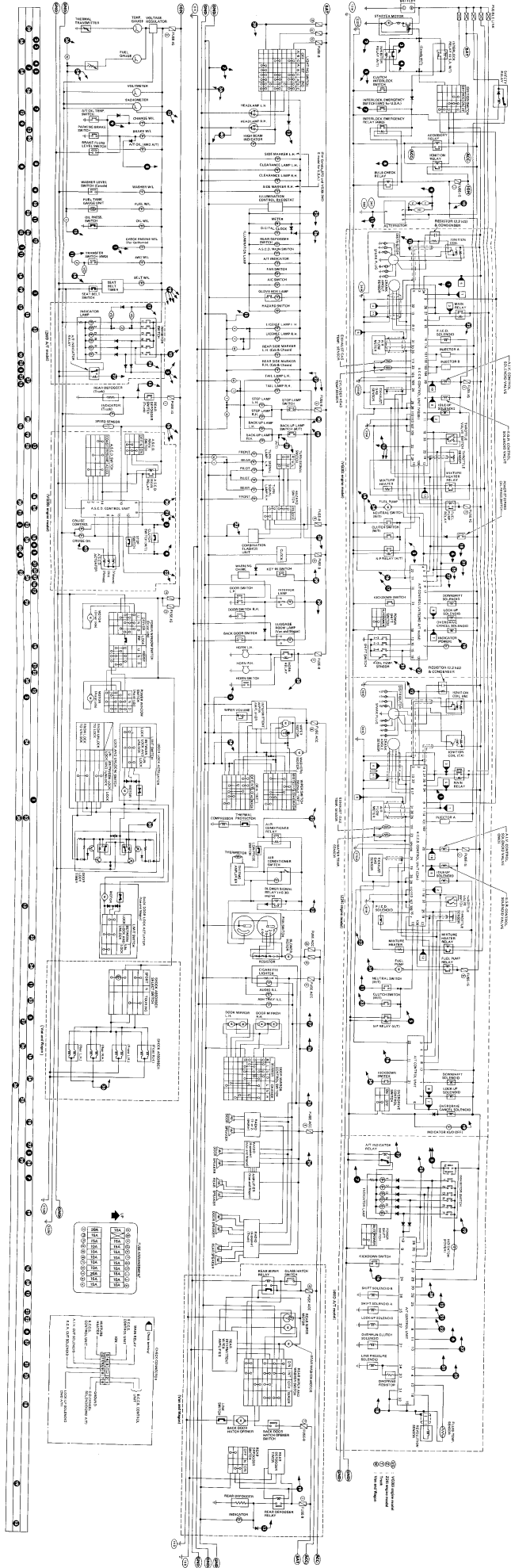

INCH TO METRIC CONVERSION TABLE

(Rounded-off for automotive use)

inches	mm	inches	mm
.100	2.54	.610	15.49
.110	2.79	.620	15.75
.120	3.05	.630	16.00
.130	3.30	.640	16.26
.140	3.56	.650	16.51
.150	3.81	.660	16.76
.160	4.06	.670	17.02
.170	4.32	.680	17.27
.180	4.57	.690	17.53
.190	4.83	.700	17.78
.200	5.08	.710	18.03
.210	5.33	.720	18.29
.220	5.59	.730	18.54
.230	5.84	.740	18.80
.240	6.10	.750	19.05
.250	6.35	.760	19.30
.260	6.60	.770	19.56
.270	6.86	.780	19.81
.280	7.11	.790	20.07
.290	7.37	.800	20.32
.300	7.62	.810	20.57
.310	7.87	.820	20.83
.320	8.13	.830	21.08
.330	8.38	.840	21.34
.340	8.64	.850	21.59
.350	8.89	.860	21.84
.360	9.14	.870	22.10
.370	9.40	.880	22.35
.380	9.65	.890	22.61
.390	9.91	.900	22.86
.400	10.16	.910	23.11
.410	10.41	.920	23.37
.420	10.67	.930	23.62
.430	10.92	.940	23.88
.440	11.18	.950	24.11
.450	11.43	.960	24.38
.460	11.68	.970	24.64
.470	11.94	.980	24.89
.480	12.19	.990	25.15
.490	12.45	1.000	25.40
.500	12.70	2.000	50.80
.510	12.95	3.000	76.20
.520	13.21	4.000	101.60
.530	13.46	5.000	127.00
.540	13.72	6.000	152.40
.550	13.97	7.000	177.80
.560	14.22	8.000	203.20
.570	14.48	9.000	228.60
.580	14.73	10.000	254.00
.590	14.99	20.000	508.00
.600	15.24		

METRIC TO INCH CONVERSION TABLE

(Rounded-off for automotive use)

mm	inches	mm	inches
1	.0394	51	2.008
2	.079	52	2.047
3	.118	53	2.087
4	.157	54	2.126
5	.197	55	2.165
6	.236	56	2.205
7	.276	57	2.244
8	.315	58	2.283
9	.354	59	2.323
10	.394	60	2.362
11	.433	61	2.402
12	.472	62	2.441
13	.512	63	2.480
14	.551	64	2.520
15	.591	65	2.559
16	.630	66	2.598
17	.669	67	2.638
18	.709	68	2.677
19	.748	69	2.717
20	.787	70	2.756
21	.827	71	2.795
22	.866	72	2.835
23	.906	73	2.874
24	.945	74	2.913
25	.984	75	2.953
26	1.024	76	2.992
27	1.063	77	3.031
28	1.102	78	3.071
29	1.142	79	3.110
30	1.181	80	3.150
31	1.220	81	3.189
32	1.260	82	3.228
33	1.299	83	3.268
34	1.339	84	3.307
35	1.378	85	3.346
36	1.417	86	3.386
37	1.457	87	3.425
38	1.496	88	3.465
39	1.535	89	3.504
40	1.575	90	3.543
41	1.614	91	3.583
42	1.654	92	3.622
43	1.693	93	3.661
44	1.732	94	3.701
45	1.772	95	3.740
46	1.811	96	3.780
47	1.850	97	3.819
48	1.890	98	3.858
49	1.929	99	3.898
50	1.969	100	3.937

QUICK REFERENCE CHART : TRUCK / PATHFINDER 1989

ENGINE TUNE-UP DATA VG30i

Model		VG30i		
Idle speed	rpm	See page MA-16	800±50	
	M/T A/T (in "D" position)		700±50	
Ignition timing (degree B.T.D.C. at idle speed)		12±2 See page EF & EC-205		
Dash pot touch speed	rpm	M/T: 1,600 - 1,800	A/T: 2,000 - 2,200	
Spark plug (Standard type)		BCPR5ES-11		
Drive belt deflection (Cold)	mm (in)	Used belt		Set deflection of new belt
		Limit	Adjust	
Alternator		12 (0.47)	6 - 8 (0.24 - 0.31)	5 - 7 (0.20 - 0.28)
Air conditioner compressor		16 (0.63)	9 - 11 (0.35 - 0.43)	7 - 9 (0.28 - 0.35)
Power steering oil pump		17 (0.67)	11 - 13 (0.43 - 0.51)	9 - 11 (0.35 - 0.43)
Applied pushing force	N (kg, lb)	98 (10, 22)		

ENGINE TUNE-UP DATA Z24i

Model		Z24i		
Idle speed	rpm	See page MA-25	800±50	
	M/T A/T (in "D" position)		650±50	
Ignition timing (degree B.T.D.C. at idle speed)		10±2 See page EF & EC-205		
Dash pot touch speed	rpm	A/T: 1,600 - 2,000		
Valve clearance (Hot)	Intake	See page MA-24	0.30 (0.012)	
	Exhaust		0.30 (0.012)	
Spark plug (Standard type)		BPR5ES		
Drive belt deflection (Cold)	mm (in)	Used belt		Set deflection of new belt
		Limit	Adjust	
Alternator		16 (0.63)	9 - 11 (0.35 - 0.43)	7 - 9 (0.28 - 0.35)
Air conditioner compressor		13 (0.51)	8 - 10 (0.31 - 0.39)	6 - 8 (0.24 - 0.31)
Power steering oil pump		16 (0.63)	10 - 12 (0.39 - 0.47)	8 - 10 (0.31 - 0.39)
Applied pushing force	N (kg, lb)	98 (10, 22)		

WHEEL ALIGNMENT (Unladen*1)

Applied model		SERVICE CHECKING		SERVICE SETTING	
		2WD	4WD	2WD	4WD
Camber	degree	-20' to 1°10' [25'±45']	-5' to 1°25' [40'±45']	25'±30'	40'±30'
Caster	degree	-23' to 1°07' [22'±45']	33' - 2°03' [1°18'±45']	22'±30'	1°18'±30'
Kingpin inclination	degree	8°20' - 9°50' [9°05'±45']	7°21' - 8°51' [8°06'±45']	9°05'±30'	8°06'±30'
Toe-in (Total toe-in)	mm (in) degree		2 - 6 (0.08 - 0.24) 10' - 28'		
Radial tire		1 - 5 (0.04 - 0.20) 7' - 27'	4±2 (0.16±0.08) 19±9'	3±1 (0.12±0.04) 17±5'	4±1 (0.16±0.04) 17±5'
		3±2 (0.12±0.08) 17'±10'	0 - 4 (0 - 0.16)*2 0' - 19'	2±1 17±5'	2±1 (0.08±0.04)*2 10'±5'

*1: Tankful of fuel, radiator coolant and engine oil full.
Spare tire, jack, and tools, mats in designated positions.
*2: Van and Wagon model

CLUTCH PEDAL

		Unit: mm (in)	
Height		VG30i: 227 - 237 (8.94 - 9.33)	
		Z24i: 236 - 246 (9.29 - 9.69)	
Free play		1 - 1.5 (0.039 - 0.059)	

BRAKE

		Unit: mm (in)	
Disc brake	Pad minimum thickness	2.0 (0.079)	
	Rotor repair limit		
	Runout	0.07 (0.0028) or less	
Minimum thickness		20.0 (0.787), CL28VA	
		24.0 (0.945), CL28VD	
		16.0 (0.630), AD14VB	
Drum brake	Lining minimum thickness	1.5 (0.059)	
	Drum repair limit		
Maximum inner diameter	Single-tire:	261.5 (10.30), LT26B	
	Dual-tire:	255.5 (10.06), DS25B, DS25C	
		191.0 (7.52), DS19HB	
Radial runout		0.05 (0.0020) or less	
		0.1 (0.004) or less*1	
Out-of-roundness		0.03 (0.0012) or less	
		0.04 (0.0016) or less*1	
Pedal free height	M/T model	212 - 222 (8.35 - 8.74)	
	A/T model	209 - 219 (8.23 - 8.62)	
Pedal depressed height*2		120 (4.72) or more	

*1: DS19HB only
*2: Under force of 490 N (50 kg, 110 lb) with engine running

FRONT WHEEL BEARING

Item	Model		2WD		4WD		
Tightening torque	N-m (kg-m, ft-lb)		34 - 39 (3.5 - 4.0, 25 - 29)		-		
Return angle	degree		45°		-		
Preload (At hub bolt)	N (kg, lb)		New seal	9.8 - 28.4 (1.0 - 2.9, 2.2 - 6.4)		Wheel bearing lock nut Tightening torque N-m (kg-m, ft-lb)	78 - 98 (8 - 10, 58 - 72)
			Used seal	9.8 - 23.5 (1.0 - 2.4, 2.2 - 5.3)		Retightening torque after loosening wheel bearing lock nut N-m (kg-m, ft-lb)	0.5 - 1.5 (0.05 - 0.15, 0.4 - 1.1)
Starting force at wheel hub bolt	N (kg, lb)					Axial end play mm (in)	0 (0)
						Turning angle degree	15° - 30°
Starting force at wheel hub bolt	N (kg, lb)					B	
Wheel bearing preload at wheel hub bolt	N (kg, lb)					7.06 - 20.99 (0.72 - 2.14, 1.59 - 4.72)	

 **NISSAN MOTOR CO., LTD.**
Overseas Service Department
Tokyo, Japan

Edition: July 1988
Printing: July 1988 (07)
Publication No. SM9E-0D21U0

Printed in Japan